



## EMI TEST REPORT

### Test Report No.: 26KE0199-HO-D-1

**Applicant** : **KYOCERA Corporation**  
**Type of Equipment** : **iBurst User Terminal**  
**Model No. / FCC ID** : **UTD1900D-US-B / JOYIUD19AB**  
**UTU1900D-US-A / JOYIUU19AB**  
**UTC1900D-US-B / JOYIUC19AB**  
**Test standard** : **FCC Part 15 Subpart B Class B 2006**  
**Test Result** : **Complied**

1. This test report shall not be reproduced in full or partial, without the written approval of UL Apex Co., Ltd.
2. The results in this report apply only to the sample tested.
3. This equipment is in compliance with the above regulation.
4. The test results in this report are traceable to the national or international standards.
5. This test report must not be used by the client product certification, approval, or endorsement by NVLAP, NIST, or any agency of the Federal Government.

**Date of test:**

July 31 to August 18, 2006

**Tested by:**

Kenichi Adachi  
EMC Services

**Approved by :**

Naoki Sakamoto  
Group Leader of  
EMC Services



NVLAP LAB CODE: 200572-0

This laboratory is accredited by the NVLAP LAB CODE 200572-0, U.S.A. The tests reported herein have been performed in accordance with its terms of accreditation.

\*As for the range of Accreditation in NVLAP, you may refer to the WEB address, <http://ulapex.jp/emc/nvlap.htm>

**UL Apex Co., Ltd.**

**Head Office EMC Lab.**

4383-326 Asama-cho, Ise-shi, Mie-ken 516-0021 JAPAN

Telephone : +81 596 24 8116

Facsimile : +81 596 24 8124

MF060b(14.06.06)

<b>CONTENTS</b>	<b>PAGE</b>
<b>SECTION 1: Client information.....</b>	<b>3</b>
<b>SECTION 2: Equipment under test (E.U.T.) .....</b>	<b>3</b>
<b>SECTION 3: Test specification, procedures &amp; results .....</b>	<b>4</b>
<b>SECTION 4: Operation of E.U.T. during testing.....</b>	<b>6</b>
<b>SECTION 5: Conducted Emission .....</b>	<b>8</b>
<b>SECTION 6: Radiated Emission .....</b>	<b>9</b>
<b>APPENDIX 1: Photographs of test setup.....</b>	<b>10</b>
Conducted Emission .....	10
Radiated Emission .....	14
<b>APPENDIX 2: Data of EMI test .....</b>	<b>18</b>
Conducted Emission .....	18
Radiated Emission .....	22
<b>APPENDIX 3: Test instruments .....</b>	<b>26</b>

## **SECTION 1: Client information**

Company Name : KYOCERA Corporation  
Address : Yokohama Office  
2-1-1 Kagahara, Tsuzuki-ku, Yokohama-shi, Kanagawa 224-8502, Japan  
Telephone Number : +81-45-943-6189  
Facsimile Number : +81-45-943-6123  
Contact Person : Toshihiko Kawata

## **SECTION 2: Equipment under test (E.U.T.)**

### **2.1 Identification of E.U.T.**

Type of Equipment : iBurst User Terminal  
Model No. : UTD1900D-US-B  
UTU1900D-US-A  
UTC1900D-US-B  
Serial No. : UTD1900D-US-B: 01  
UTU1900D-US-A: 01  
UTC1900D-US-B: 01  
Rating : UTD1900D-US-B: AC 120V/60Hz (AC Adapter), DC 8.55-9.45V (EUT)  
UTU1900D-US-A: AC 120V/60Hz (Host PC's AC Adapter)  
DC 4.5-5.5V(EUT)  
UTC1900D-US-B: AC 120V/60Hz (Host PC's AC Adapter)  
DC 2.97-3.63V (EUT)  
Country of Manufacture : JAPAN  
Receipt Date of Sample : July 28, 2006  
Condition of EUT : Production model  
Modification of EUT : No modification by the test lab.

### **2.2 Product Description**

Model Nos.: UTD1900D-US-B/UTU1900D-US-A/UTC1900D-US-B (referred to as the EUT in this report) are iBurst User Terminal.

Equipment Type : Transceiver  
Frequency operation : 1900-1910MHz  
Type of modulation : BPSK,QPSK,8PSK,12QAM,16QAM  
Bandwidth : 500kHz  
Channel spacing : 625kHz  
Channel number : 16  
Antenna Type : Integrated mono-pole antenna (UTD1900D-US-B)  
Chip antenna (UTU1900D-US-A, UTC1900D-US-B)  
Antenna connector Type : MMCX  
Antenna Gain : 4dBi (UTD1900D-US-B)  
0dBi (UTU1900D-US-A, UTC1900D-US-B)  
Other Clock Frequency : 72MHz, 25MHz (UTD1900D-US-B only), 24MHz, 20MHz, 18MHz,  
6MHz, 3MHz, 32.768kHz  
Temperature of operation : 0 deg. C. to + 40 deg. C.

---

## **UL Apex Co., Ltd.**

### **Head Office EMC Lab.**

4383-326 Asama-cho, Ise-shi, Mie-ken 516-0021 JAPAN

Telephone : +81 596 24 8116

Facsimile : +81 596 24 8124

MF060b(14.06.06)

### **SECTION 3: Test specification, procedures & results**

#### **3.1 Test specification**

Test Specification : FCC Part 15 Subpart B 2006  
Title : FCC 47CFR Part15 Radio Frequency Device  
Subpart B Unintentional Radiators

#### **3.2 Procedures and results**

Item	Test Procedure	Limits	Deviati on	Worst margin *0)	Result
Conducted emission	ANSI C63.4: 2003 7. AC powerline conducted emission measurements	Class B	N/A	[UTD1900D-US-B] 10.2dB, 24.13505MHz, AV, L (USB) [UTU1900D-US-A] 15.8dB, 0.19870MHz, QP, L [UTC1900D-US-B] 14.4dB, 0.20148MHz, QP, L	Complied
Radiated emission	ANSI C63.4: 2003 8. Radiated emission measurements	Class B	N/A	[UTD1900D-US-B] 3.8dB, 566.960MHz, Vertical (LAN) [UTU1900D-US-A] 7.4dB, 54.290MHz, Vertical [UTC1900D-US-B] 8.2dB, 54.290MHz, Horizontal	Complied

\*Note: UL Apex's EMI Work Procedure QPM05.

\*0) The result is rounded off to the second decimal place. Therefore, there may be 0.1 difference for the result.

\*These tests were performed without any deviations from test procedure except for additions or exclusions.

#### **3.3 Additions or deviations to standards**

No addition, deviation, nor exclusion has been made from standards.

#### **3.4 Confirmation**

UL Apex Co., Ltd. hereby confirms that E.U.T., in the configuration tested, complies with the specifications, FCC Part15 Subpart B 2006.

**UL Apex Co., Ltd.**

**Head Office EMC Lab.**

4383-326 Asama-cho, Ise-shi, Mie-ken 516-0021 JAPAN

Telephone : +81 596 24 8116

Facsimile : +81 596 24 8124

MF060b(14.06.06)

### 3.5 Uncertainty

#### Conducted Emission

The measurement uncertainty (with a 95% confidence level) for this test was  $\pm 2.6$ dB.  
The data listed in this test report has enough margin, more than the site margin.

#### Radiated Emission

The measurement uncertainty (with a 95% confidence level) for this test using Loop antenna is  $\pm 4.41$ dB(3m).  
The measurement uncertainty (with a 95% confidence level) for this test using Biconical antenna is  $\pm 4.59$ dB(3m).  
The measurement uncertainty (with a 95% confidence level) for this test using Logperiodic antenna is  $\pm 4.62$ dB(3m).  
The measurement uncertainty (with a 95% confidence level) for this test using Horn antenna is  $\pm 5.27$ dB.

#### [UTD1900D-US-B]

The data listed in this report meets the limits unless the uncertainty is taken into consideration.

#### [UTU1900D-US-A, UTC1900D-US-B]

The data listed in this test report has enough margin, more than the site margin.

### 3.6 Test Location

UL Apex Co., Ltd. Head Office EMC Lab. \*NVLAP Lab. code: 200572-0  
4383-326 Asama-cho, Ise-shi, Mie-ken 516-0021 JAPAN  
Telephone: +81 596 24 8116 Facsimile: +81 596 24 8124

	FCC Registration Number	IC Registration Number	Width x Depth x Height (m)	Size of reference ground plane (m) / horizontal conducting plane	Other rooms
No.1 semi-anechoic chamber	313583	IC4247A	19.2 x 11.2 x 7.7m	7.0 x 6.0m	Preparation room
No.2 semi-anechoic chamber	655103	IC4247A-2	7.5 x 5.8 x 5.2m	4.0 x 4.0m	-
No.3 semi-anechoic chamber	148738	IC4247A-3	12.0 x 8.5 x 5.9m	6.8 x 5.75m	
No.3 shielded room	-	-	4.0 x 6.0 x 2.7m	N/A	-
No.4 semi-anechoic chamber	134570	IC4247A-4	12.0 x 8.5 x 5.9m	6.8 x 5.75m	-
No.4 shielded room	-	-	4.0 x 6.0 x 2.7m	N/A	-
No.5 semi-anechoic chamber	-	-	6.0 x 6.0 x 3.9m	N/A	-
No.6 shielded room	-	-	4.0 x 4.5 x 2.7m	2.0 x 2.0 m	-
No.6 measurement room	-	-	4.75 x 5.4 x 3.0m	4.75 x 5.4 m	-
No.7 shielded room	-	-	4.7 x 7.5 x 2.7m	4.7 x 7.5m	-
No.8 measurement room	-	-	3.1 x 5.0 x 2.7m	N/A	-

\* Size of vertical conducting plane (for Conducted Emission test) : 2.0 x 2.0m for No.1, No.2, No. 3, and No.4 semi-anechoic chambers and No.7 shielded room.

### 3.7 Test set up, Test instruments and Data of EMI

Refer to APPENDIX 1 to 3.

## UL Apex Co., Ltd.

### Head Office EMC Lab.

4383-326 Asama-cho, Ise-shi, Mie-ken 516-0021 JAPAN

Telephone : +81 596 24 8116

Facsimile : +81 596 24 8124

MF060b(14.06.06)

## SECTION 4: Operation of E.U.T. during testing

### 4.1 Operating modes

The mode is used : Receiving mode

### 4.2 Configuration and peripherals

#### [UTD1900D-US-B]

(USB connect)

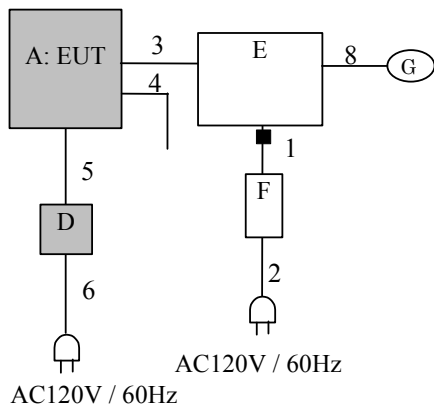

(LAN connect)

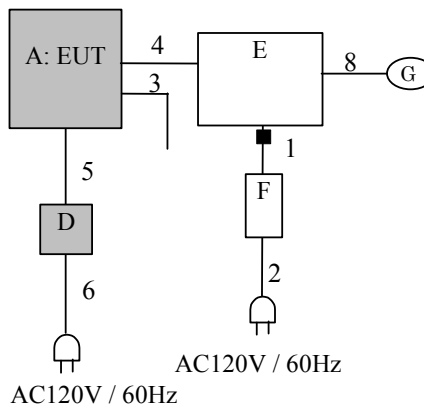

■ Standard Ferrite Core for E.

#### [UTU1900D-US-A]

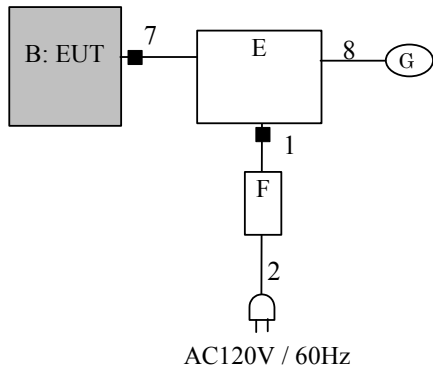

■ Standard Ferrite Core.

#### [UTC1900D-US-B]

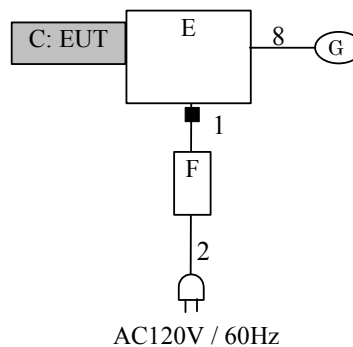

■ Standard Ferrite Core for E.

\*Cabling and setup were taken into consideration and test data was taken under worse case conditions.

**UL Apex Co., Ltd.**

**Head Office EMC Lab.**

4383-326 Asama-cho, Ise-shi, Mie-ken 516-0021 JAPAN

Telephone : +81 596 24 8116

Facsimile : +81 596 24 8124

MF060b(14.06.06)

**Description of EUT and support equipment**

No.	Item	Model number	Serial number	Manufacturer	Remark
A	iBurst User Terminal	UTD1900D-US-B	01	KYOCERA	EUT
B	iBurst User Terminal	UTU1900D-US-A	01	KYOCERA	EUT
C	iBurst User Terminal	UTC1900D-US-B	01	KYOCERA	EUT
D	AC Adapter	TYPEFW7400/09	2106B	FWHK	EUT
E	PC	TYPE2662-LBJ	FX-FL781	IBM	-
F	AC Adapter for PC	AA21131	11S02K6657Z1Z0ZA0651R X	IBM	-
G	Mouse	M-U48a	LNA12600205	Logitech	-

**List of cables used**

No.	Name	Length (m)	Shield		Remarks
			Cable	Connector	
1	DC Cable	1.8	Unshielded	Unshielded	-
2	AC Cable	1.0	Unshielded	Unshielded	-
3	USB Cable	2.0	Shielded	Shielded	-
4	LAN Cable	2.0	Unshielded	Unshielded	-
5	DC Cable	2.0	Unshielded	Unshielded	-
6	AC Cable	2.0	Unshielded	Unshielded	-
7	USB Cable	1.0	Shielded	Shielded	-
8	Mouse Cable	1.9	Unshielded	Unshielded	-

---

**UL Apex Co., Ltd.**

**Head Office EMC Lab.**

4383-326 Asama-cho, Ise-shi, Mie-ken 516-0021 JAPAN

Telephone : +81 596 24 8116

Facsimile : +81 596 24 8124

MF060b(14.06.06)

## **SECTION 5: Conducted Emission**

### **5.1 Operating environment**

Test place : No.2 / No.3 semi anechoic chamber.  
Temperature : See data  
Humidity : See data

### **5.2 Test configuration**

EUT was placed on a urethane platform / a wooden table of nominal size, 0.5m by 1.0 m (for UTD-1900D-US- B) / 1m by 1.5m (for UTU-1900D-US-A and UTC-1900D-US-B), raised 80cm above the conducting ground plane. The rear of tabletop was located 40cm to the vertical conducting plane. The rear of EUT and its peripherals was aligned and flushed with rear of tabletop. All other surfaces of tabletop were at least 80cm from any other grounded conducting surface. EUT was located 80cm from the LISN/AMN and excess AC cable was bundled in center. They were folded back and forth forming a bundle 30cm to 40cm long and were hanged at a 40cm height to the ground plane. Each EUT current-carrying power lead, except the ground (safety) lead, was individually connected through a LISN/AMN to the input power source. All unused 50 ohm connectors of the LISN/AMN were resistivity terminated in 50 ohm when not connected to the measuring equipment. A drawing of the set up is shown in the photos of APPENDIX 1.

\*EUT was located 80cm from LISN/AMN and excess AC cable was bundled in center. I/O cables that were connected to the other peripherals.

### **5.3 Test conditions**

Frequency range : 0.15 MHz-30MHz  
EUT position : Table top  
EUT operation mode : See Clause 4.1

### **5.4 Test procedure**

The AC Mains Terminal Continuous disturbance Voltage has been measured with the EUT within a semi anechoic chamber. The EUT was connected to a Line Impedance Stabilization Network (LISN)/ Artificial Mains network (AMN). An overview sweep with peak detection has been performed. The measurements have been performed with a quasi-peak detector and if required, with an average detector.

The conducted emission measurements were made with the following detector function of the test receiver.

Detector Type : Quasi-Peak and Average  
IF Bandwidth : 9 kHz

### **5.5 Test result**

Summary of the test results: Pass

Date: July 31 and August 18, 2006

Test engineer: Kenichi Adachi

---

**UL Apex Co., Ltd.**

**Head Office EMC Lab.**

4383-326 Asama-cho, Ise-shi, Mie-ken 516-0021 JAPAN

Telephone : +81 596 24 8116

Facsimile : +81 596 24 8124

MF060b(14.06.06)



## **SECTION 6: Radiated Emission**

### **6.1 Operating environment**

Test place : No.2 semi anechoic chamber  
Temperature : See data  
Humidity : See data

### **6.2 Test configuration**

EUT was placed on a urethane platform of nominal size, 1.0m by 1.0m, raised 80cm above the conducting ground plane. The EUT was set on the center of the tabletop.  
Test was made with the antenna positioned in both the horizontal and vertical planes of polarization. The measurement antenna was varied in height above the conducting ground plane to obtain the maximum signal strength.  
A drawing of the set up is shown in the photos of APPENDIX 1.

### **6.3 Test conditions**

Frequency range : 30MHz – 300MHz (Biconical antenna) / 300MHz – 1000MHz (Logperiodic antenna)  
Test distance : 3m  
EUT position : Table top  
EUT operation mode : See Clause 4.1

### **6.4 Test procedure**

The height of the measuring varied between 1 and 4m and EUT was rotated a full revolution in order to obtain the maximum value of the electric field intensity.  
The measurements were performed for both vertical and horizontal antenna polarization with the Test Receiver, or the Spectrum Analyzer (in linear mode).  
The test was made with the detector (RBW/VBW) in the following table.  
When using Spectrum analyzer, the test was made with adjusting span to zero by using peak hold.

Frequency	Below 1GHz
Instrument used	Test Receiver
IF Bandwidth	QP: BW 120kHz

### **6.5 Test result**

Summary of the test results: Pass

Date: July 31, 2006

Test engineer: Kenichi Adachi

---

**UL Apex Co., Ltd.**

**Head Office EMC Lab.**

4383-326 Asama-cho, Ise-shi, Mie-ken 516-0021 JAPAN

Telephone : +81 596 24 8116

Facsimile : +81 596 24 8124

MF060b(14.06.06)