

# FCC Test Report

## (PART 27)

**Report No.:** RFBHAA-WTW-P20090611-2

**FCC ID:** JOYDA39

**Test Model:** AL-T51A2-2

**Series Model:** AL-T52V1, AL-T51A2-1 (refer to item 3.1 for more details)

**Received Date:** Sep. 26, 2020

**Test Date:** Sep. 29 ~ Oct. 06, 2020

**Issued Date:** Oct. 15, 2020

**Applicant:** Kyocera Corporation

**Address:** 2-1-1 Kagahara, Tsuzuki-ku Yokohama-city Kanagawa 224-8502 Japan

**Issued By:** Bureau Veritas Consumer Products Services (H.K.) Ltd., Taoyuan Branch  
Lin Kou Laboratories

**Lab Address:** No. 47-2, 14th Ling, Chia Pau Vil., Lin Kou Dist., New Taipei City, Taiwan

**Test Location:** No. 19, Hwa Ya 2nd Rd., Wen Hwa Vil., Kwei Shan Dist., Taoyuan City  
33383, Taiwan

**FCC Registration /  
Designation Number:** 788550 / TW0003



This report is for your exclusive use. Any copying or replication of this report to or for any other person or entity, or use of our name or trademark, is permitted only with our prior written permission. This report sets forth our findings solely with respect to the test samples identified herein. The results set forth in this report are not indicative or representative of the quality or characteristics of the lot from which a test sample was taken or any similar or identical product specifically and expressly noted. Our report includes all of the tests requested by you and the results thereof based upon the information that you provided to us. You have 60 days from date of issuance of this report to notify us of any material error or omission caused by our negligence, provided, however, that such notice shall be in writing and shall specifically address the issue you wish to raise. A failure to raise such issue within the prescribed time shall constitute your unqualified acceptance of the completeness of this report, the tests conducted and the correctness of the report contents. Unless specific mention, the uncertainty of measurement has been explicitly taken into account to declare the compliance or non-compliance to the specification.

## Table of Contents

<b>Release Control Record</b> .....	<b>3</b>
<b>1 Certificate of Conformity</b> .....	<b>4</b>
<b>2 Summary of Test Results</b> .....	<b>5</b>
2.1 Measurement Uncertainty.....	6
2.2 Test Site and Instruments .....	7
<b>3 General Information</b> .....	<b>7</b>
3.1 General Description of EUT.....	8
3.2 Configuration of System under Test.....	10
3.2.1 Description of Support Units.....	10
3.3 Test Mode Applicability and Tested Channel Detail .....	11
3.4 EUT Operating Conditions .....	12
3.5 General Description of Applied Standards and references .....	12
<b>4 Test Types and Results</b> .....	<b>13</b>
4.1 Output Power Measurement.....	13
4.1.1 Limits of Output Power Measurement .....	13
4.1.2 Test Procedures.....	13
4.1.3 Test Setup.....	14
4.1.4 Test Results .....	15
4.2 Radiated Emission Measurement.....	23
4.2.1 Limits of Radiated Emission Measurement .....	23
4.2.2 Test Procedure .....	23
4.2.3 Deviation from Test Standard .....	23
4.2.4 Test Setup.....	24
4.2.5 Test Results .....	25
<b>5 Pictures of Test Arrangements</b> .....	<b>33</b>
<b>Appendix – Information of the Testing Laboratories</b> .....	<b>34</b>

### Release Control Record

Issue No.	Description	Date Issued
RFBHAA-WTW-P20090611-2	Original Release	Oct. 15, 2020

## 1 Certificate of Conformity

**Product:** Telematics Module

**Brand:** Kyocera

**Test Model:** AL-T51A2-2

**Series Model:** AL-T52V1, AL-T51A2-1 (refer to item 3.1 for more details)

**Sample Status:** Engineering Sample

**Applicant:** Kyocera Corporation

**Test Date:** Sep. 29 ~ Oct. 06, 2020

**Standards:** FCC Part 27, Subpart C, H, L

This report is issued as a supplementary report of RFBHAA-WTW-P20070391-2. This report shall be used combined together with its original report.

**Prepared by :** Pettie Chen , **Date:** Oct. 15, 2020  
Pettie Chen / Senior Specialist

**Approved by :** Bruce Chen , **Date:** Oct. 15, 2020  
Bruce Chen / Senior Project Engineer

## 2 Summary of Test Results

Applied Standard: FCC Part 27 & Part 2 (WCDMA Band 4)			
FCC Clause	Test Item	Result	Remarks
2.1046 27.50(d)(4)	Equivalent Isotropic Radiated Power	Pass	Meet the requirement of limit.
2.1047	Modulation Characteristics	N/A	Refer to Note 1
2.1055 27.54	Frequency Stability	N/A	Refer to Note 1
2.1049	Occupied Bandwidth	N/A	Refer to Note 1
27.50(d)(5)	Peak to Average Ratio	N/A	Refer to Note 1
27.53(h)	Band Edge Measurements	N/A	Refer to Note 1
2.1051 27.53(h)	Conducted Spurious Emissions	N/A	Refer to Note 1
2.1053 27.53(h)	Radiated Spurious Emissions	Pass	Meet the requirement of limit. Minimum passing margin is -22.6 dB at 33.88 MHz.

Applied Standard: FCC Part 27 & Part 2 (LTE Band 4)			
FCC Clause	Test Item	Result	Remarks
2.1046 27.50(d)(4)	Equivalent Isotropic Radiated Power	Pass	Meet the requirement of limit.
2.1047	Modulation Characteristics	N/A	Refer to Note 1
2.1055 27.54	Frequency Stability	N/A	Refer to Note 1
2.1049	Occupied Bandwidth	N/A	Refer to Note 1
27.50(d)(5)	Peak to Average Ratio	N/A	Refer to Note 1
27.53(h)	Band Edge Measurements	N/A	Refer to Note 1
2.1051 27.53(h)	Conducted Spurious Emissions	N/A	Refer to Note 1
2.1053 27.53(h)	Radiated Spurious Emissions	Pass	Meet the requirement of limit. Minimum passing margin is -23.2 dB at 159.98 MHz.

Applied Standard: FCC Part 27 & Part 2 (LTE Band 12)			
FCC Clause	Test Item	Result	Remarks
2.1046 27.50(c)(10)	Effective Isotropic Radiated Power	Pass	Meet the requirement of limit.
2.1047	Modulation Characteristics	N/A	Refer to Note 1
2.1055 27.54	Frequency Stability	N/A	Refer to Note 1
2.1049	Occupied Bandwidth	N/A	Refer to Note 1
---	Peak to Average Ratio	N/A	Refer to Note 1
27.53(g)	Band Edge Measurements	N/A	Refer to Note 1
2.1051 27.53(g)	Conducted Spurious Emissions	N/A	Refer to Note 1
2.1053 27.53(g)	Radiated Spurious Emissions	Pass	Meet the requirement of limit. Minimum passing margin is -27.6 dB at 161.92 MHz.

N/A: Not Applicable

Note:

1. The equivalent isotropic radiated power and radiated spurious emissions test items are performed for the addendum, according to the worst case of the original report. Refer to original report for the other test data.
2. Determining compliance based on the results of the compliance measurement, not taking into account measurement instrumentation uncertainty.

## 2.1 Measurement Uncertainty

Where relevant, the following measurement uncertainty levels have been estimated for tests performed on the EUT as specified in CISPR 16-4-2:

Measurement	Frequency	Expanded Uncertainty (k=2) (±)
Radiated Emissions up to 1 GHz	9 kHz ~ 30 MHz	3.04 dB
	30 MHz ~ 200 MHz	3.63 dB
	200 MHz ~ 1000 MHz	3.64 dB
Radiated Emissions above 1 GHz	1 GHz ~ 18 GHz	2.29 dB
	18 GHz ~ 40 GHz	2.29 dB

## 2.2 Test Site and Instruments

Description & Manufacturer	Model No.	Serial No.	Date of Calibration	Due Date of Calibration
Test Receiver ROHDE & SCHWARZ	ESCI	100424	Dec. 31, 2019	Dec. 30, 2020
Spectrum Analyzer ROHDE & SCHWARZ	FSP40	100040	Sep. 16, 2020	Sep. 15, 2021
BILOG Antenna SCHWARZBECK	VULB9168	9168-155	Nov. 11, 2019	Nov. 10, 2020
HORN Antenna SCHWARZBECK	BBHA 9120D	9120D-1170	Nov. 24, 2019	Nov. 23, 2020
HORN Antenna SCHWARZBECK	BBHA 9170	BBHA9170241	Nov. 24, 2019	Nov. 23, 2020
Preamplifier Agilent (Below 1GHz)	8447D	2944A10631	Jun. 08, 2020	Jun. 07, 2021
Preamplifier KEYSIGHT (Above 1GHz)	83017A	MY53270295	Jun. 08, 2020	Jun. 07, 2021
RF Coaxial Cable WOKEN With 5dB PAD	8D-FB	Cable-CH4-01	Aug. 16, 2020	Aug. 15, 2021
RF Coaxial Cable EMCI	EMC102-KM-KM-3000	150929	Aug. 16, 2020	Aug. 15, 2021
RF Coaxial Cable EMCI	EMC102-KM-KM-600	150928	Aug. 16, 2020	Aug. 15, 2021
RF signal cable HUBER+SUHNER	SUCOFLEX 104	MY 13380+295012/04	Jun. 08, 2020	Jun. 07, 2021
RF signal cable HUBER+SUHNER	SUCOFLEX 104	Cable-CH4-03 (250724)	Jun. 08, 2020	Jun. 07, 2021
Software BV ADT	ADT_Radiated_ V7.6.15.9.5	NA	NA	NA
Antenna Tower inn-co GmbH	MA 4000	010303	NA	NA
Antenna Tower Controller BV ADT	AT100	AT93021703	NA	NA
Turn Table BV ADT	TT100	TT93021703	NA	NA
Turn Table Controller BV ADT	SC100	SC93021703	NA	NA
Boresight Antenna Fixture	FBA-01	FBA-SIP01	NA	NA
Pre-amplifier (18GHz-40GHz) EMC	EMC184045B	980175	Sep. 04, 2020	Sep. 03, 2021
JFW 20dB attenuation	50HF-020-SMA	NA	NA	NA

- Note: 1. The calibration interval of the above test instruments is 12 months and the calibrations are traceable to NML/ROC and NIST/USA.  
 2. The test was performed in HwaYa Chamber 4.

### 3 General Information

#### 3.1 General Description of EUT

<b>Product</b>	Telematics Module	
<b>Brand</b>	Kyocera	
<b>Test Model</b>	AL-T51A2-2	
<b>Series Model</b>	AL-T52V1, AL-T51A2-1	
<b>Status of EUT</b>	Engineering Sample	
<b>Power Supply Rating</b>	5Vdc	
<b>Modulation Type</b>	WCDMA	QPSK
	LTE	QPSK, 16QAM
<b>Frequency Range</b>	WCDMA Band 4	1712.4 ~ 1752.6 MHz
	LTE Band 4 (Channel Bandwidth: 1.4 MHz)	1710.7 ~ 1754.3 MHz
	LTE Band 4 (Channel Bandwidth: 3 MHz)	1711.5 ~ 1753.5 MHz
	LTE Band 4 (Channel Bandwidth: 5 MHz)	1712.5 ~ 1752.5 MHz
	LTE Band 4 (Channel Bandwidth: 10 MHz)	1715.0 ~ 1750.0 MHz
	LTE Band 4 (Channel Bandwidth: 15 MHz)	1717.5 ~ 1747.5 MHz
	LTE Band 4 (Channel Bandwidth: 20 MHz)	1720.0 ~ 1745.0 MHz
	LTE Band 12 (Channel Bandwidth: 1.4 MHz)	699.7 ~ 715.3 MHz
	LTE Band 12 (Channel Bandwidth: 3 MHz)	700.5 ~ 714.5 MHz
	LTE Band 12 (Channel Bandwidth: 5 MHz)	701.5 ~ 713.5 MHz
	LTE Band 12 (Channel Bandwidth: 10 MHz)	704.0 ~ 711.0 MHz
<b>Max. EIRP Power</b>	WCDMA Band 4	64.565 mW (18.10dBm)
	LTE Band 4 (Channel Bandwidth: 1.4 MHz)	263.027 mW (24.20dBm)
	LTE Band 4 (Channel Bandwidth: 3 MHz)	275.423 mW (24.40dBm)
	LTE Band 4 (Channel Bandwidth: 5 MHz)	218.776 mW (23.40dBm)
	LTE Band 4 (Channel Bandwidth: 10 MHz)	281.838 mW (24.50dBm)
	LTE Band 4 (Channel Bandwidth: 15 MHz)	251.189 mW (24.00dBm)
	LTE Band 4 (Channel Bandwidth: 20 MHz)	263.027 mW (24.20dBm)
	LTE Band 12 (Channel Bandwidth: 1.4 MHz)	245.471 mW (23.90dBm)
	LTE Band 12 (Channel Bandwidth: 3 MHz)	218.776 mW (23.40dBm)
	LTE Band 12 (Channel Bandwidth: 5 MHz)	223.872 mW (23.50dBm)
LTE Band 12 (Channel Bandwidth: 10 MHz)	229.087 mW (23.60dBm)	
<b>Antenna Type</b>	Refer to Note as below	
<b>Accessory Device</b>	Refer to Note as below	
<b>Data Cable Supplied</b>	Refer to Note as below	

Note:

1. This report is prepared for FCC class II permissive change. The differences compared with the original report (BV CPS report no.: RFBHAA-WTW-P20070391-2) are adding a model and changing software & memory capacity. The effective radiated power and radiated spurious emissions test items are performed for the addendum, according to the worst case of the original report. Refer to original report for the other test data.
2. All models are listed as below. (New model is marked in boldface.)

Brand	Model	Difference
Kyocera	AL-T52V1	Support WCDMA Band 2, 4, 5 and LTE Band 2, 4, 5, 12, 13
	AL-T51A2-1	Support WCDMA Band 2, 4, 5 and LTE Band 2, 4, 5, 12
	<b>AL-T51A2-2</b>	Support band same with AL-T51A2-1, just different memory and driver software



3. The EUT uses following antennas (support units).

Antenna 1					
Antenna Type	AUX		Connector Type		SMA
Manufacturer	YOKOWO		Part Number		86769-459B1
Band	B12	B13	B5 / B26	B4	B2
Frequency (MHz)	704	782	832	1730	1880
Gain (dBi)	3.1	3.2	3.8	2.6	2.0

Antenna 2					
Antenna Type	AUX		Connector Type		SMA
Manufacturer	taoglas		Part Number		TG.30.8113
Band	B12	B5 / B26		B4	B2
Frequency (MHz)	700-800	824-960		1710-1880	1850-1990
Free Space Straight Gain (dBi)	1.1	0.3		1.9	2.7
Free Space Bent Gain (dBi)	2.6	1.5		2.7	3.1

Antenna 3					
Antenna Type	AUX		Connector Type		Inverted-F
Manufacturer	MinebeaMitsumi		Part Number		DN4E 66T30
Band	B12 / B13		B5 / B26	B4	B2
Frequency (MHz)	700-800		824-960	1710-1880	1850-1990
Gain (dBd)	-0.3		-0.3	0.4	0.4
Gain (dBi)	1.85		1.85	2.55	2.55

dBi = dBd + 2.15

Antenna 4					
Antenna Type	External		Connector Type		Inverted-F
Manufacturer	Mitsumi Electric		Part Number		KJK966 T30
Band	B12 / B13		B5 / B26	B4	B2
Frequency (MHz)	700-800		824-960	1710-1880	1850-1990
Gain (dBi)	1.0		1.0	0.4	0.4

Antenna 5					
Antenna Type	External		Connector Type		Inverted-F
Manufacturer	HARADA INDUSTRY		Part Number		TD2K 66 T30
Band	B12 / B13		B5 / B26	B4	B2
Frequency (MHz)	700-800		824-960	1710-1880	1850-1990
Gain (dBi)	-2.1		-2.1	-1.2	-1.2

For WCDMA Band 2 and LTE Band 2: Antenna 2 was chosen for final test according to manufacturer's requirement.

For WCDMA Band 4, 5 and LTE Band 4, 5, 12, 13, 26: Antenna 1 was chosen for final test according to manufacturer's requirement.

4. The above Antenna information is declared by manufacturer and for more detailed features description, please refer to the manufacturer's specifications, the laboratory shall not be held responsible

### 3.2 Configuration of System under Test

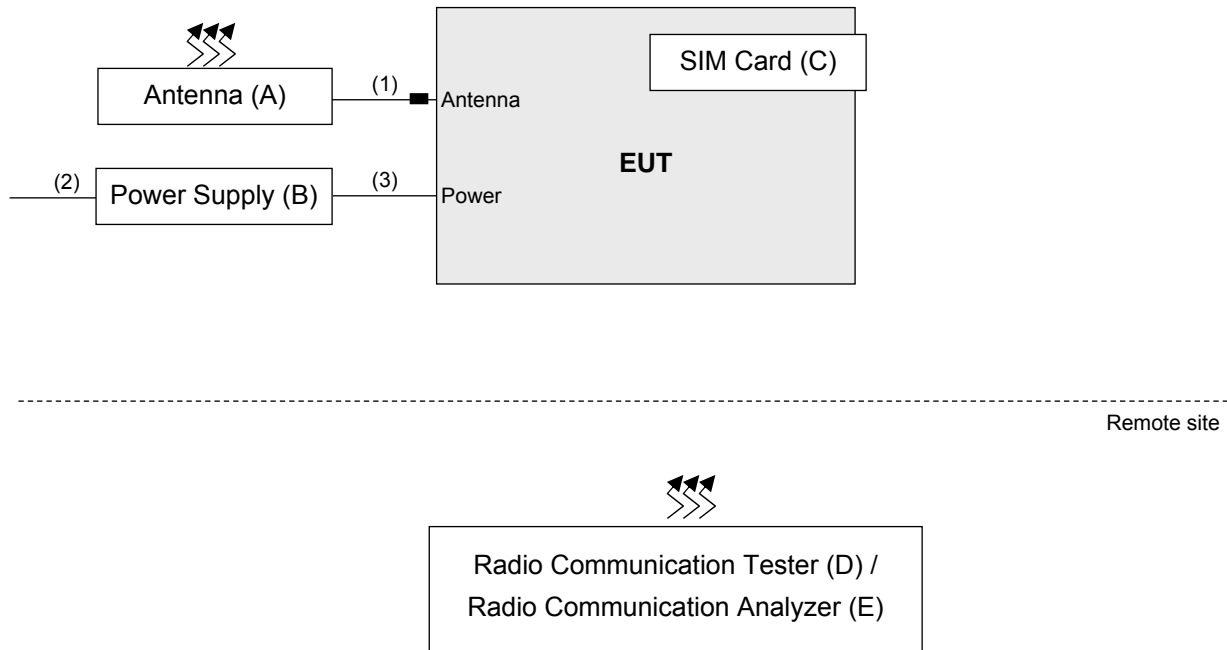

#### 3.2.1 Description of Support Units

The EUT has been tested as an independent unit together with other necessary accessories or support units. The following support units or accessories were used to form a representative test configuration during the tests.

ID	Product	Brand	Model No.	Serial No.	FCC ID	Remarks
A.	Antenna	taoglas	TG.30.8113	NA	NA	Provided by manufacturer
B.	Power Supply	Inspower	DC400-20D	212004	FCC DoC Approved	Provided by manufacturer Input:100-240Vac, 0.4A, 50-60Hz Output: 5Vdc, 3A
C.	SIM Card	NA	NA	NA	NA	Provided by manufacturer
D.	Radio Communication Tester	R&S	CMU200	123112	NA	-
E.	Radio Communication Analyzer	Anritsu	MT8820C	6201300640	NA	-

Note:

1. All power cords of the above support units are non-shielded (1.8m).
2. Item D and E acted as a communication partners to transfer data.

ID	Descriptions	Qty.	Length (m)	Shielding (Yes/No)	Cores (Qty.)	Remarks
1.	Antenna	1	3	N	1	Provided by manufacturer
2.	Power	1	1.75	N	0	Provided by manufacturer
3.	Module cable	2	0.08	N	0	Attached on EUT

Note: The core(s) is(are) originally attached to the cable(s).

### 3.3 Test Mode Applicability and Tested Channel Detail

Pre-Scan has been conducted to determine the worst-case mode from all possible combinations between available modulations, data rates, XYZ axis and antenna ports. The worst case was found when positioned on Z-plane. Following channel(s) was (were) selected for the final test as listed below.

#### WCDMA Band 4

EUT Configure Mode	Test Item	Available Channel	Tested Channel	Mode
-	EIRP	1312 to 1513	1312 (1712.4MHz), 1413 (1732.6MHz), 1513 (1752.6MHz)	WCDMA
-	Radiated Emission	1312 to 1513	1312 (1712.4MHz)	WCDMA

#### LTE Band 4

EUT Configure Mode	Test Item	Available Channel	Tested Channel	Channel Bandwidth	Modulation	Mode
-	EIRP	19957 to 20393	19957 (1710.7MHz), 20175 (1732.5MHz), 20175 (1732.5MHz)	1.4MHz	QPSK	1 RB / 0 RB Offset
		19965 to 20385	19965 (1711.5MHz), 20175 (1732.5MHz), 20385 (1753.5MHz)	3MHz	QPSK	1 RB / 0 RB Offset
		19975 to 20375	19975 (1712.5MHz), 20175 (1732.5MHz), 20375 (1752.5MHz)	5MHz	QPSK	1 RB / 0 RB Offset
		20000 to 20350	20000 (1715.0MHz), 20175 (1732.5MHz), 20350 (1750.0MHz)	10MHz	QPSK	1 RB / 0 RB Offset
		20025 to 20325	20025 (1717.5MHz), 20175 (1732.5MHz), 20325 (1747.5MHz)	15MHz	QPSK	1 RB / 0 RB Offset
		20050 to 20300	20050 (1720.0MHz), 20175 (1732.5MHz), 20300 (1745.0MHz)	20MHz	QPSK	1 RB / 0 RB Offset
-	Radiated Emission	20000 to 20350	20350 (1750.0MHz)	10MHz	QPSK	1 RB / 0 RB Offset

#### LTE Band 12

EUT Configure Mode	Test Item	Available Channel	Tested Channel	Channel Bandwidth	Modulation	Mode
-	EIRP	23017 to 23171	23017 (699.7MHz), 23095 (707.5MHz), 23173 (715.3MHz)	1.4MHz	QPSK	1 RB / 0 RB Offset
		23025 to 23165	23025 (700.5MHz), 23095 (707.5MHz), 23165 (714.5MHz)	3MHz	QPSK	1 RB / 0 RB Offset
		23035 to 23155	23035 (701.5MHz), 23095 (707.5MHz), 23155 (713.5MHz)	5MHz	QPSK	1 RB / 0 RB Offset
		23060 to 23130	23060 (704.0MHz), 23095 (707.5MHz), 23130 (711.0MHz)	10MHz	QPSK	1 RB / 0 RB Offset
-	Radiated Emission	23017 to 23173	23173 (715.3MHz)	1.4 MHz	QPSK	1 RB / 0 RB Offset

**Test Condition:**

Test Item	Environmental Conditions	Input Power	Tested By
EIRP	25deg. C, 70%RH	120Vac, 60Hz	Luis Lee
Radiated Emission	25deg. C, 70%RH	120Vac, 60Hz	Noah Chang

**3.4 EUT Operating Conditions**

The EUT makes a call to the communication simulator. The communication simulator station system controlled a EUT to export maximum output power under transmission mode and specific channel frequency

**3.5 General Description of Applied Standards and references**

The EUT is a RF Product. According to the specifications of the manufacturer, it must comply with the requirements of the following standards and references:

**Test Standard:**

**FCC 47 CFR Part 2**

**FCC 47 CFR Part 27**

**ANSI 63.26-2015**

**Note:** All test items have been performed and recorded as per the above standards.

**References Test Guidance:**

**KDB 971168 D01 Power Meas License Digital Systems v03r01**

**ANSI/TIA/EIA-603-E 2016**

**Note:** All test items have been performed as a reference to the above KDB test guidance.

## 4 Test Types and Results

### 4.1 Output Power Measurement

#### 4.1.1 Limits of Output Power Measurement

Fixed, mobile, and portable (hand-held) stations operating in the 1710–1755 MHz band and mobile and portable stations operating in the 1695-1710 MHz and 1755-1780 MHz bands are limited to 1 watt EIRP.

Portable stations (hand-held device) operating in the 600 MHz uplink band and the 698-746 MHz band, and fixed and mobile stations in the 600 MHz uplink band are limited to 3 watts ERP.

#### 4.1.2 Test Procedures

##### **EIRP / ERP Measurement:**

- a. All measurements were done at low, middle and high operational frequency range. RBW and VBW is 5 MHz for WCDMA and 20 MHz for LTE mode, and  $VBW \geq 3 \times RBW$ .
- b. Substitution method is used for E.I.R.P measurement. In the semi-anechoic chamber, EUT placed on the 0.8 m (below or equal 1 GHz) and/or 1.5 m (above 1 GHz) height of Turn Table, rotated the table around 360 degrees to search the maximum radiation power and receiver antenna shall be rotated vertical and horizontal polarization and moved height from 1 m to 4 m to find the maximum polar radiated power. The “Read Value” is the spectrum reading the maximum power value.
- c. The substitution horn antenna is substituted for EUT at the same position and signals generator export the CW signal to the substitution antenna via a tx cable. Rotated the Turn Table and moved receiving antenna to find the maximum radiation power. Adjust output power level of S.G to get a Value of spectrum reading equal to “Read Value” of step b. Record the power level of S.G.
- d.  $EIRP = \text{Output power level of S.G} - \text{TX cable loss} + \text{Antenna gain of substitution horn}$ . E.R.P power can be calculated form E.I.R.P power by subtracting the gain of dipole,  $E.R.P \text{ power} = E.I.R.P \text{ power} - 2.15 \text{ dB}$ .

4.1.3 Test Setup

**EIRP / ERP Measurement:  
<Radiated Emission below or equal 1 GHz>**

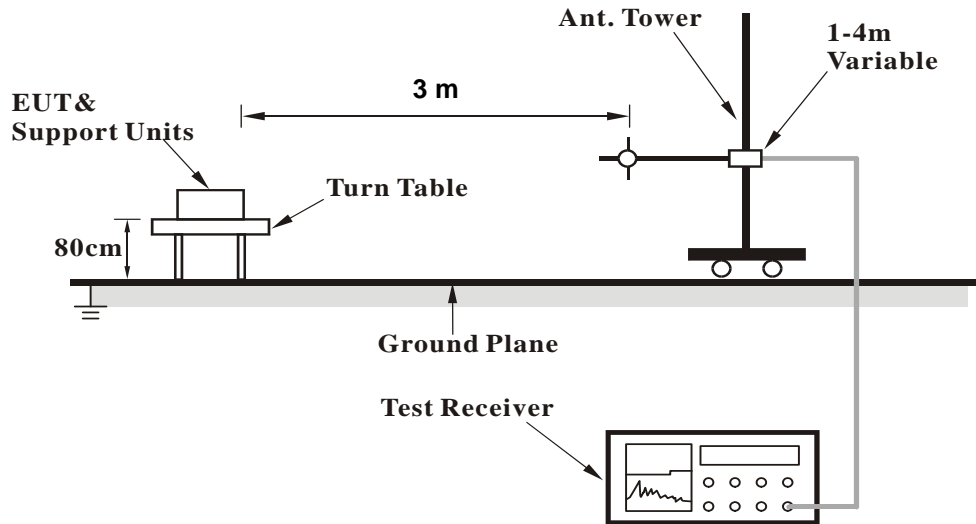

**<Radiated Emission above 1 GHz>**

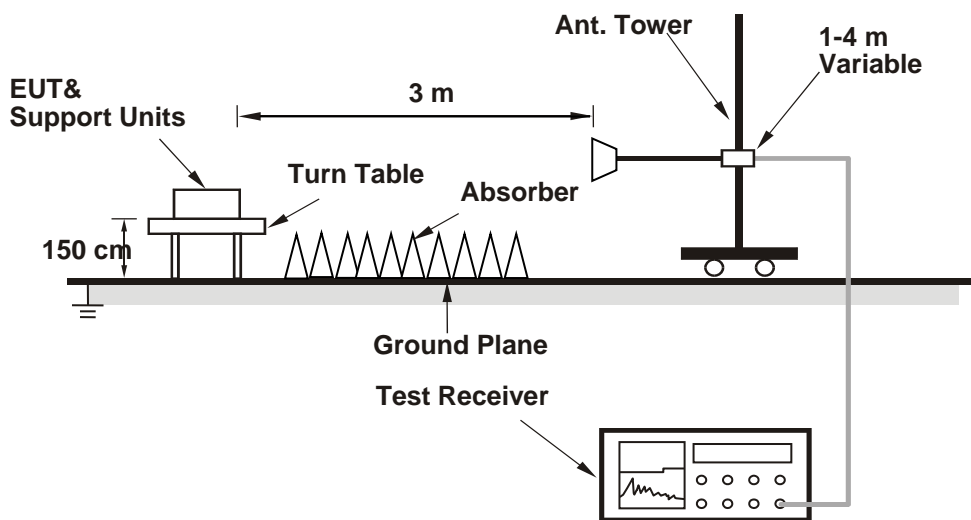

For the actual test configuration, please refer to the attached file (Test Setup Photo).

#### 4.1.4 Test Results

##### WCDMA Band IV

ANTENNA POLARITY & TEST DISTANCE: HORIZONTAL AT 3 M							
Channel	FREQ. (MHz)	READING (dBm)	S.G POWER VALUE (dBm)	CORRECTION FACTOR (dB)	EIRP (dBm)	LIMIT (dBm)	MARGIN (dB)
1312	1712.40 (PK)	-24.8	13.7	1.0	14.7	30.0	-15.3
1413	1732.60 (PK)	-26.5	12.2	1.0	13.2	30.0	-16.8
1513	1752.60 (PK)	-26.6	12.2	1.1	13.3	30.0	-16.7
ANTENNA POLARITY & TEST DISTANCE: VERTICAL AT 3 M							
Channel	FREQ. (MHz)	READING (dBm)	S.G POWER VALUE (dBm)	CORRECTION FACTOR (dB)	EIRP (dBm)	LIMIT (dBm)	MARGIN (dB)
1312	1712.40 (PK)	-22.1	17.1	1.0	18.1	30.0	-11.9
1413	1732.60 (PK)	-22.8	16.4	1.0	17.4	30.0	-12.6
1513	1752.60 (PK)	-22.2	16.9	1.1	18.0	30.0	-12.0

**NOTE:** Power Value(dBm) = S.G Power Value(dBm) + Correction Factor(dB)

##### QPSK

##### LTE Band 4, Channel Bandwidth 1.4MHz

ANTENNA POLARITY & TEST DISTANCE: HORIZONTAL AT 3 M							
Channel	FREQ. (MHz)	READING (dBm)	S.G POWER VALUE (dBm)	CORRECTION FACTOR (dB)	EIRP (dBm)	LIMIT (dBm)	MARGIN (dB)
19957	1710.70 (PK)	-15.4	23.0	1.0	24.0	30.0	-6.0
20175	1732.50 (PK)	-15.9	22.8	1.0	23.8	30.0	-6.2
20393	1754.30 (PK)	-15.7	23.1	1.1	24.2	30.0	-5.8
ANTENNA POLARITY & TEST DISTANCE: VERTICAL AT 3 M							
Channel	FREQ. (MHz)	READING (dBm)	S.G POWER VALUE (dBm)	CORRECTION FACTOR (dB)	EIRP (dBm)	LIMIT (dBm)	MARGIN (dB)
19957	1710.70 (PK)	-23.9	15.3	1.0	16.3	30.0	-13.7
20175	1732.50 (PK)	-24.2	15.0	1.0	16.0	30.0	-14.0
20393	1754.30 (PK)	-23.9	15.2	1.1	16.3	30.0	-13.7

**NOTE:** Power Value(dBm) = S.G Power Value(dBm) + Correction Factor(dB)

#### LTE Band 4, Channel Bandwidth 3MHz

ANTENNA POLARITY & TEST DISTANCE: HORIZONTAL AT 3 M							
Channel	FREQ. (MHz)	READING (dBm)	S.G POWER VALUE (dBm)	CORRECTION FACTOR (dB)	EIRP (dBm)	LIMIT (dBm)	MARGIN (dB)
19965	1711.50 (PK)	-15.1	23.4	1.0	24.4	30.0	-5.6
20175	1732.50 (PK)	-15.7	23.0	1.0	24.0	30.0	-6.0
20385	1753.50 (PK)	-16.3	22.5	1.1	23.6	30.0	-6.4
ANTENNA POLARITY & TEST DISTANCE: VERTICAL AT 3 M							
Channel	FREQ. (MHz)	READING (dBm)	S.G POWER VALUE (dBm)	CORRECTION FACTOR (dB)	EIRP (dBm)	LIMIT (dBm)	MARGIN (dB)
19965	1711.50 (PK)	-23.9	15.3	1.0	16.3	30.0	-13.7
20175	1732.50 (PK)	-24.9	14.3	1.0	15.3	30.0	-14.7
20385	1753.50 (PK)	-23.9	15.2	1.1	16.3	30.0	-13.7

**NOTE:** Power Value(dBm) = S.G Power Value(dBm) + Correction Factor(dB)

#### LTE Band 4, Channel Bandwidth 5MHz

ANTENNA POLARITY & TEST DISTANCE: HORIZONTAL AT 3 M							
Channel	FREQ. (MHz)	READING (dBm)	S.G POWER VALUE (dBm)	CORRECTION FACTOR (dB)	EIRP (dBm)	LIMIT (dBm)	MARGIN (dB)
19975	1712.50 (PK)	-16.2	22.3	1.0	23.3	30.0	-6.7
20175	1732.50 (PK)	-16.4	22.3	1.0	23.3	30.0	-6.7
20375	1752.50 (PK)	-16.4	22.3	1.1	23.4	30.0	-6.6
ANTENNA POLARITY & TEST DISTANCE: VERTICAL AT 3 M							
Channel	FREQ. (MHz)	READING (dBm)	S.G POWER VALUE (dBm)	CORRECTION FACTOR (dB)	EIRP (dBm)	LIMIT (dBm)	MARGIN (dB)
19975	1712.50 (PK)	-25.2	14.0	1.0	15.0	30.0	-15.0
20175	1732.50 (PK)	-24.6	14.6	1.0	15.6	30.0	-14.4
20375	1752.50 (PK)	-24.4	14.7	1.1	15.8	30.0	-14.2

**NOTE:** Power Value(dBm) = S.G Power Value(dBm) + Correction Factor(dB)

#### LTE Band 4, Channel Bandwidth 10MHz

ANTENNA POLARITY & TEST DISTANCE: HORIZONTAL AT 3 M							
Channel	FREQ. (MHz)	READING (dBm)	S.G POWER VALUE (dBm)	CORRECTION FACTOR (dB)	EIRP (dBm)	LIMIT (dBm)	MARGIN (dB)
20000	1715.00 (PK)	-15.5	23.0	1.0	24.0	30.0	-6.0
20175	1732.50 (PK)	-16.3	22.4	1.0	23.4	30.0	-6.6
20350	1750.00 (PK)	-15.3	23.4	1.1	24.5	30.0	-5.5
ANTENNA POLARITY & TEST DISTANCE: VERTICAL AT 3 M							
Channel	FREQ. (MHz)	READING (dBm)	S.G POWER VALUE (dBm)	CORRECTION FACTOR (dB)	EIRP (dBm)	LIMIT (dBm)	MARGIN (dB)
20000	1715.00 (PK)	-25.2	14.0	1.0	15.0	30.0	-15.0
20175	1732.50 (PK)	-25.0	14.2	1.0	15.2	30.0	-14.8
20350	1750.00 (PK)	-24.1	15.0	1.1	16.1	30.0	-13.9

**NOTE:** Power Value(dBm) = S.G Power Value(dBm) + Correction Factor(dB)



### LTE Band 4, Channel Bandwidth 15MHz

ANTENNA POLARITY & TEST DISTANCE: HORIZONTAL AT 3 M							
Channel	FREQ. (MHz)	READING (dBm)	S.G POWER VALUE (dBm)	CORRECTION FACTOR (dB)	EIRP (dBm)	LIMIT (dBm)	MARGIN (dB)
20025	1717.50 (PK)	-15.5	23.0	1.0	24.0	30.0	-6.0
20175	1732.50 (PK)	-15.9	22.8	1.0	23.8	30.0	-6.2
20325	1747.50 (PK)	-15.9	22.8	1.1	23.9	30.0	-6.1
ANTENNA POLARITY & TEST DISTANCE: VERTICAL AT 3 M							
Channel	FREQ. (MHz)	READING (dBm)	S.G POWER VALUE (dBm)	CORRECTION FACTOR (dB)	EIRP (dBm)	LIMIT (dBm)	MARGIN (dB)
20025	1717.50 (PK)	-24.3	14.9	1.0	15.9	30.0	-14.1
20175	1732.50 (PK)	-24.2	15.0	1.0	16.0	30.0	-14.0
20325	1747.50 (PK)	-24.1	15.0	1.1	16.1	30.0	-13.9

**NOTE:** Power Value(dBm) = S.G Power Value(dBm) + Correction Factor(dB)

### LTE Band 4, Channel Bandwidth 20MHz

ANTENNA POLARITY & TEST DISTANCE: HORIZONTAL AT 3 M							
Channel	FREQ. (MHz)	READING (dBm)	S.G POWER VALUE (dBm)	CORRECTION FACTOR (dB)	EIRP (dBm)	LIMIT (dBm)	MARGIN (dB)
20050	1720.00 (PK)	-16.1	22.4	1.0	23.4	30.0	-6.6
20175	1732.50 (PK)	-15.5	23.2	1.0	24.2	30.0	-5.8
20300	1747.50 (PK)	-16.4	22.3	1.1	23.4	30.0	-6.6
ANTENNA POLARITY & TEST DISTANCE: VERTICAL AT 3 M							
Channel	FREQ. (MHz)	READING (dBm)	S.G POWER VALUE (dBm)	CORRECTION FACTOR (dB)	EIRP (dBm)	LIMIT (dBm)	MARGIN (dB)
20050	1720.00 (PK)	-24.9	14.3	1.0	15.3	30.0	-14.7
20175	1732.50 (PK)	-24.3	14.9	1.0	15.9	30.0	-14.1
20300	1747.50 (PK)	-24.6	14.5	1.1	15.6	30.0	-14.4

**NOTE:** Power Value(dBm) = S.G Power Value(dBm) + Correction Factor(dB)

### LTE Band 12, Channel Bandwidth 1.4MHz

ANTENNA POLARITY & TEST DISTANCE: HORIZONTAL AT 3 M							
Channel	FREQ. (MHz)	READING (dBm)	S.G POWER VALUE (dBm)	CORRECTION FACTOR (dB)	EIRP (dBm)	LIMIT (dBm)	MARGIN (dB)
23017	699.70	-7.2	23.1	-0.5	22.6	34.8	-12.2
23095	707.50	-7.0	23.6	-0.5	23.1	34.8	-11.7
23173	715.30	-6.2	24.4	-0.5	23.9	34.8	-10.9
ANTENNA POLARITY & TEST DISTANCE: VERTICAL AT 3 M							
Channel	FREQ. (MHz)	READING (dBm)	S.G POWER VALUE (dBm)	CORRECTION FACTOR (dB)	EIRP (dBm)	LIMIT (dBm)	MARGIN (dB)
23017	699.70	-17.3	16.1	-0.5	15.6	34.8	-19.2
23095	707.50	-17.5	16.2	-0.5	15.7	34.8	-19.1
23173	715.30	-17.6	16.4	-0.5	15.9	34.8	-18.9

**NOTE:** Power Value(dBm) = S.G Power Value(dBm) + Correction Factor(dB)

### LTE Band 12, Channel Bandwidth 3MHz

ANTENNA POLARITY & TEST DISTANCE: HORIZONTAL AT 3 M							
Channel	FREQ. (MHz)	READING (dBm)	S.G POWER VALUE (dBm)	CORRECTION FACTOR (dB)	EIRP (dBm)	LIMIT (dBm)	MARGIN (dB)
23025	700.50	-7.7	22.7	-0.5	22.2	34.8	-12.6
23095	707.50	-7.1	23.5	-0.5	23.0	34.8	-11.8
23165	714.50	-6.6	23.9	-0.5	23.4	34.8	-11.4
ANTENNA POLARITY & TEST DISTANCE: VERTICAL AT 3 M							
Channel	FREQ. (MHz)	READING (dBm)	S.G POWER VALUE (dBm)	CORRECTION FACTOR (dB)	EIRP (dBm)	LIMIT (dBm)	MARGIN (dB)
23025	700.50	-17.7	15.7	-0.5	15.2	34.8	-19.6
23095	707.50	-17.7	16.0	-0.5	15.5	34.8	-19.3
23165	714.50	-17.4	16.5	-0.5	16.0	34.8	-18.8

**NOTE:** Power Value(dBm) = S.G Power Value(dBm) + Correction Factor(dB)

### LTE Band 12, Channel Bandwidth 5MHz

ANTENNA POLARITY & TEST DISTANCE: HORIZONTAL AT 3 M							
Channel	FREQ. (MHz)	READING (dBm)	S.G POWER VALUE (dBm)	CORRECTION FACTOR (dB)	EIRP (dBm)	LIMIT (dBm)	MARGIN (dB)
23035	701.50	-7.5	22.9	-0.5	22.4	34.8	-12.4
23095	707.50	-7.3	23.3	-0.5	22.8	34.8	-12.0
23155	713.50	-6.5	24.0	-0.5	23.5	34.8	-11.3
ANTENNA POLARITY & TEST DISTANCE: VERTICAL AT 3 M							
Channel	FREQ. (MHz)	READING (dBm)	S.G POWER VALUE (dBm)	CORRECTION FACTOR (dB)	EIRP (dBm)	LIMIT (dBm)	MARGIN (dB)
23035	701.50	-17.3	16.1	-0.5	15.6	34.8	-19.2
23095	707.50	-17.2	16.5	-0.5	16.0	34.8	-18.8
23155	713.50	-17.1	16.7	-0.5	16.2	34.8	-18.6

**NOTE:** Power Value(dBm) = S.G Power Value(dBm) + Correction Factor(dB)

### LTE Band 12, Channel Bandwidth 10MHz

ANTENNA POLARITY & TEST DISTANCE: HORIZONTAL AT 3 M							
Channel	FREQ. (MHz)	READING (dBm)	S.G POWER VALUE (dBm)	CORRECTION FACTOR (dB)	EIRP (dBm)	LIMIT (dBm)	MARGIN (dB)
23060	704.00	-7.4	23.3	-0.5	22.8	34.8	-12.0
23095	707.50	-7.1	23.5	-0.5	23.0	34.8	-11.8
23130	711.00	-6.3	24.1	-0.5	23.6	34.8	-11.2
ANTENNA POLARITY & TEST DISTANCE: VERTICAL AT 3 M							
Channel	FREQ. (MHz)	READING (dBm)	S.G POWER VALUE (dBm)	CORRECTION FACTOR (dB)	EIRP (dBm)	LIMIT (dBm)	MARGIN (dB)
23060	704.00	-17.3	16.4	-0.5	15.9	34.8	-18.9
23095	707.50	-17.2	16.5	-0.5	16.0	34.8	-18.8
23130	711.00	-17.1	16.6	-0.5	16.1	34.8	-18.7

**NOTE:** Power Value(dBm) = S.G Power Value(dBm) + Correction Factor(dB)

### 16QAM

### LTE Band 4, Channel Bandwidth 1.4MHz

ANTENNA POLARITY & TEST DISTANCE: HORIZONTAL AT 3 M							
Channel	FREQ. (MHz)	READING (dBm)	S.G POWER VALUE (dBm)	CORRECTION FACTOR (dB)	EIRP (dBm)	LIMIT (dBm)	MARGIN (dB)
19957	1710.70 (PK)	-16.4	22.0	1.0	23.0	30.0	-7.0
20175	1732.50 (PK)	-16.9	21.8	1.0	22.8	30.0	-7.2
20393	1754.30 (PK)	-16.7	22.1	1.1	23.2	30.0	-6.8
ANTENNA POLARITY & TEST DISTANCE: VERTICAL AT 3 M							
Channel	FREQ. (MHz)	READING (dBm)	S.G POWER VALUE (dBm)	CORRECTION FACTOR (dB)	EIRP (dBm)	LIMIT (dBm)	MARGIN (dB)
19957	1710.70 (PK)	-24.9	14.3	1.0	15.3	30.0	-14.7
20175	1732.50 (PK)	-25.2	14.0	1.0	15.0	30.0	-15.0
20393	1754.30 (PK)	-24.9	14.2	1.1	15.3	30.0	-14.7

**NOTE:** Power Value(dBm) = S.G Power Value(dBm) + Correction Factor(dB)

#### LTE Band 4, Channel Bandwidth 3MHz

ANTENNA POLARITY & TEST DISTANCE: HORIZONTAL AT 3 M							
Channel	FREQ. (MHz)	READING (dBm)	S.G POWER VALUE (dBm)	CORRECTION FACTOR (dB)	EIRP (dBm)	LIMIT (dBm)	MARGIN (dB)
19965	1711.50 (PK)	-16.1	22.4	1.0	23.4	30.0	-6.6
20175	1732.50 (PK)	-16.7	22.0	1.0	23.0	30.0	-7.0
20385	1753.50 (PK)	-17.3	21.5	1.1	22.6	30.0	-7.4
ANTENNA POLARITY & TEST DISTANCE: VERTICAL AT 3 M							
Channel	FREQ. (MHz)	READING (dBm)	S.G POWER VALUE (dBm)	CORRECTION FACTOR (dB)	EIRP (dBm)	LIMIT (dBm)	MARGIN (dB)
19965	1711.50 (PK)	-24.9	14.3	1.0	15.3	30.0	-14.7
20175	1732.50 (PK)	-25.9	13.3	1.0	14.3	30.0	-15.7
20385	1753.50 (PK)	-24.9	14.2	1.1	15.3	30.0	-14.7

**NOTE:** Power Value(dBm) = S.G Power Value(dBm) + Correction Factor(dB)

#### LTE Band 4, Channel Bandwidth 5MHz

ANTENNA POLARITY & TEST DISTANCE: HORIZONTAL AT 3 M							
Channel	FREQ. (MHz)	READING (dBm)	S.G POWER VALUE (dBm)	CORRECTION FACTOR (dB)	EIRP (dBm)	LIMIT (dBm)	MARGIN (dB)
19975	1712.50 (PK)	-17.2	21.3	1.0	22.3	30.0	-7.7
20175	1732.50 (PK)	-17.4	21.3	1.0	22.3	30.0	-7.7
20375	1752.50 (PK)	-17.4	21.3	1.1	22.4	30.0	-7.6
ANTENNA POLARITY & TEST DISTANCE: VERTICAL AT 3 M							
Channel	FREQ. (MHz)	READING (dBm)	S.G POWER VALUE (dBm)	CORRECTION FACTOR (dB)	EIRP (dBm)	LIMIT (dBm)	MARGIN (dB)
19975	1712.50 (PK)	-26.2	13.0	1.0	14.0	30.0	-16.0
20175	1732.50 (PK)	-25.6	13.6	1.0	14.6	30.0	-15.4
20375	1752.50 (PK)	-25.4	13.7	1.1	14.8	30.0	-15.2

**NOTE:** Power Value(dBm) = S.G Power Value(dBm) + Correction Factor(dB)

#### LTE Band 4, Channel Bandwidth 10MHz

ANTENNA POLARITY & TEST DISTANCE: HORIZONTAL AT 3 M							
Channel	FREQ. (MHz)	READING (dBm)	S.G POWER VALUE (dBm)	CORRECTION FACTOR (dB)	EIRP (dBm)	LIMIT (dBm)	MARGIN (dB)
20000	1715.00 (PK)	-16.5	22.0	1.0	23.0	30.0	-7.0
20175	1732.50 (PK)	-17.3	21.4	1.0	22.4	30.0	-7.6
20350	1750.00 (PK)	-16.3	22.4	1.1	23.5	30.0	-6.5
ANTENNA POLARITY & TEST DISTANCE: VERTICAL AT 3 M							
Channel	FREQ. (MHz)	READING (dBm)	S.G POWER VALUE (dBm)	CORRECTION FACTOR (dB)	EIRP (dBm)	LIMIT (dBm)	MARGIN (dB)
20000	1715.00 (PK)	-26.2	13.0	1.0	14.0	30.0	-16.0
20175	1732.50 (PK)	-26.0	13.2	1.0	14.2	30.0	-15.8
20350	1750.00 (PK)	-25.1	14.0	1.1	15.1	30.0	-14.9

**NOTE:** Power Value(dBm) = S.G Power Value(dBm) + Correction Factor(dB)

### LTE Band 4, Channel Bandwidth 15MHz

ANTENNA POLARITY & TEST DISTANCE: HORIZONTAL AT 3 M							
Channel	FREQ. (MHz)	READING (dBm)	S.G POWER VALUE (dBm)	CORRECTION FACTOR (dB)	EIRP (dBm)	LIMIT (dBm)	MARGIN (dB)
20025	1717.50 (PK)	-16.5	22.0	1.0	23.0	30.0	-7.0
20175	1732.50 (PK)	-16.9	21.8	1.0	22.8	30.0	-7.2
20325	1747.50 (PK)	-16.9	21.8	1.1	22.9	30.0	-7.1
ANTENNA POLARITY & TEST DISTANCE: VERTICAL AT 3 M							
Channel	FREQ. (MHz)	READING (dBm)	S.G POWER VALUE (dBm)	CORRECTION FACTOR (dB)	EIRP (dBm)	LIMIT (dBm)	MARGIN (dB)
20025	1717.50 (PK)	-25.3	13.9	1.0	14.9	30.0	-15.1
20175	1732.50 (PK)	-25.2	14.0	1.0	15.0	30.0	-15.0
20325	1747.50 (PK)	-25.1	14.0	1.1	15.1	30.0	-14.9

**NOTE:** Power Value(dBm) = S.G Power Value(dBm) + Correction Factor(dB)

### LTE Band 4, Channel Bandwidth 20MHz

ANTENNA POLARITY & TEST DISTANCE: HORIZONTAL AT 3 M							
Channel	FREQ. (MHz)	READING (dBm)	S.G POWER VALUE (dBm)	CORRECTION FACTOR (dB)	EIRP (dBm)	LIMIT (dBm)	MARGIN (dB)
20050	1720.00 (PK)	-17.1	21.4	1.0	22.4	30.0	-7.6
20175	1732.50 (PK)	-16.5	22.2	1.0	23.2	30.0	-6.8
20300	1747.50 (PK)	-17.4	21.3	1.1	22.4	30.0	-7.6
ANTENNA POLARITY & TEST DISTANCE: VERTICAL AT 3 M							
Channel	FREQ. (MHz)	READING (dBm)	S.G POWER VALUE (dBm)	CORRECTION FACTOR (dB)	EIRP (dBm)	LIMIT (dBm)	MARGIN (dB)
20050	1720.00 (PK)	-25.9	13.3	1.0	14.3	30.0	-15.7
20175	1732.50 (PK)	-25.3	13.9	1.0	14.9	30.0	-15.1
20300	1747.50 (PK)	-25.6	13.5	1.1	14.6	30.0	-15.4

**NOTE:** Power Value(dBm) = S.G Power Value(dBm) + Correction Factor(dB)

### LTE Band 12, Channel Bandwidth 1.4MHz

ANTENNA POLARITY & TEST DISTANCE: HORIZONTAL AT 3 M							
Channel	FREQ. (MHz)	READING (dBm)	S.G POWER VALUE (dBm)	CORRECTION FACTOR (dB)	EIRP (dBm)	LIMIT (dBm)	MARGIN (dB)
23017	699.70	-8.2	22.1	-0.5	21.6	34.8	-13.2
23095	707.50	-8.0	22.6	-0.5	22.1	34.8	-12.7
23173	715.30	-7.2	23.4	-0.5	22.9	34.8	-11.9
ANTENNA POLARITY & TEST DISTANCE: VERTICAL AT 3 M							
Channel	FREQ. (MHz)	READING (dBm)	S.G POWER VALUE (dBm)	CORRECTION FACTOR (dB)	EIRP (dBm)	LIMIT (dBm)	MARGIN (dB)
23017	699.70	-18.3	15.1	-0.5	14.6	34.8	-20.2
23095	707.50	-18.5	15.2	-0.5	14.7	34.8	-20.1
23173	715.30	-18.6	15.4	-0.5	14.9	34.8	-19.9

**NOTE:** Power Value(dBm) = S.G Power Value(dBm) + Correction Factor(dB)

### LTE Band 12, Channel Bandwidth 3MHz

ANTENNA POLARITY & TEST DISTANCE: HORIZONTAL AT 3 M							
Channel	FREQ. (MHz)	READING (dBm)	S.G POWER VALUE (dBm)	CORRECTION FACTOR (dB)	EIRP (dBm)	LIMIT (dBm)	MARGIN (dB)
23025	700.50	-8.7	21.7	-0.5	21.2	34.8	-13.6
23095	707.50	-8.1	22.5	-0.5	22.0	34.8	-12.8
23165	714.50	-7.6	22.9	-0.5	22.4	34.8	-12.4
ANTENNA POLARITY & TEST DISTANCE: VERTICAL AT 3 M							
Channel	FREQ. (MHz)	READING (dBm)	S.G POWER VALUE (dBm)	CORRECTION FACTOR (dB)	EIRP (dBm)	LIMIT (dBm)	MARGIN (dB)
23025	700.50	-18.7	14.7	-0.5	14.2	34.8	-20.6
23095	707.50	-18.7	15.0	-0.5	14.5	34.8	-20.3
23165	714.50	-18.4	15.5	-0.5	15.0	34.8	-19.8

**NOTE:** Power Value(dBm) = S.G Power Value(dBm) + Correction Factor(dB)

### LTE Band 12, Channel Bandwidth 5MHz

ANTENNA POLARITY & TEST DISTANCE: HORIZONTAL AT 3 M							
Channel	FREQ. (MHz)	READING (dBm)	S.G POWER VALUE (dBm)	CORRECTION FACTOR (dB)	EIRP (dBm)	LIMIT (dBm)	MARGIN (dB)
23035	701.50	-8.5	21.9	-0.5	21.4	34.8	-13.4
23095	707.50	-8.3	22.3	-0.5	21.8	34.8	-13.0
23155	713.50	-7.5	23.0	-0.5	22.5	34.8	-12.3
ANTENNA POLARITY & TEST DISTANCE: VERTICAL AT 3 M							
Channel	FREQ. (MHz)	READING (dBm)	S.G POWER VALUE (dBm)	CORRECTION FACTOR (dB)	EIRP (dBm)	LIMIT (dBm)	MARGIN (dB)
23035	701.50	-18.3	15.1	-0.5	14.6	34.8	-20.2
23095	707.50	-18.2	15.5	-0.5	15.0	34.8	-19.8
23155	713.50	-18.1	15.7	-0.5	15.2	34.8	-19.6

**NOTE:** Power Value(dBm) = S.G Power Value(dBm) + Correction Factor(dB)

### LTE Band 12, Channel Bandwidth 10MHz

ANTENNA POLARITY & TEST DISTANCE: HORIZONTAL AT 3 M							
Channel	FREQ. (MHz)	READING (dBm)	S.G POWER VALUE (dBm)	CORRECTION FACTOR (dB)	EIRP (dBm)	LIMIT (dBm)	MARGIN (dB)
23060	704.00	-7.4	23.3	-0.5	22.8	34.8	-12.0
23095	707.50	-7.1	23.5	-0.5	23.0	34.8	-11.8
23130	711.00	-6.3	24.1	-0.5	23.6	34.8	-11.2
ANTENNA POLARITY & TEST DISTANCE: VERTICAL AT 3 M							
Channel	FREQ. (MHz)	READING (dBm)	S.G POWER VALUE (dBm)	CORRECTION FACTOR (dB)	EIRP (dBm)	LIMIT (dBm)	MARGIN (dB)
23060	704.00	-18.3	15.4	-0.5	14.9	34.8	-19.9
23095	707.50	-18.2	15.5	-0.5	15.0	34.8	-19.8
23130	711.00	-18.1	15.6	-0.5	15.1	34.8	-19.7

**NOTE:** Power Value(dBm) = S.G Power Value(dBm) + Correction Factor(dB)

## 4.2 Radiated Emission Measurement

### 4.2.1 Limits of Radiated Emission Measurement

- a. The power of any emission outside a licensee's frequency block shall be attenuated below the transmitter power (P) by at least  $43 + 10 \log (P)$  dB. The limit of emission is equal to -13 dBm.

### 4.2.2 Test Procedure

- a. Substitution method is used for E.I.R.P measurement. In the semi-anechoic chamber, EUT placed on the 0.8 m (below or equal 1 GHz) and/or 1.5 m (above 1 GHz) height of Turn Table, rotated the table around 360 degrees to search the maximum radiation power and receiver antenna shall be rotated vertical and horizontal polarization and moved height from 1 m to 4 m to find the maximum polar radiated power. The "Read Value" is the spectrum reading the maximum power value.
- b. The substitution horn antenna is substituted for EUT at the same position and signals generator export the CW signal to the substitution antenna via a TX cable. Rotated the Turn Table and moved receiving antenna to find the maximum radiation power. Adjust output power level of S.G to get a Value of spectrum reading equal to "Read Value" of step a. Record the power level of S.G.
- c. EIRP = Output power level of S.G – TX cable loss + Antenna gain of substitution horn.
- d. E.R.P power can be calculated form E.I.R.P power by subtracting the gain of dipole, E.R.P power = E.I.R.P power - 2.15 dB.

**Note:** The resolution bandwidth of spectrum analyzer is 1 MHz and the video bandwidth is 3 MHz.

### 4.2.3 Deviation from Test Standard

No deviation.

#### 4.2.4 Test Setup

##### <Radiated Emission below or equal 1 GHz>

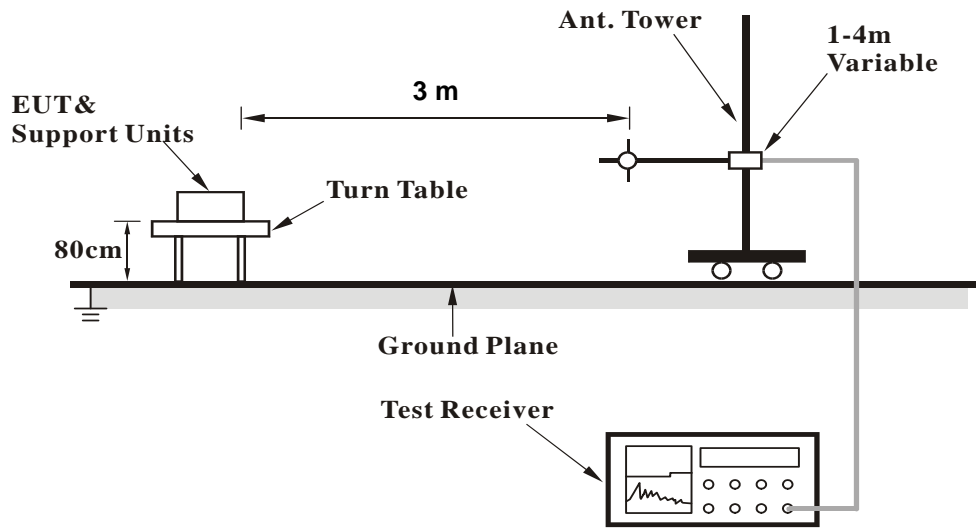

##### <Radiated Emission above 1 GHz>

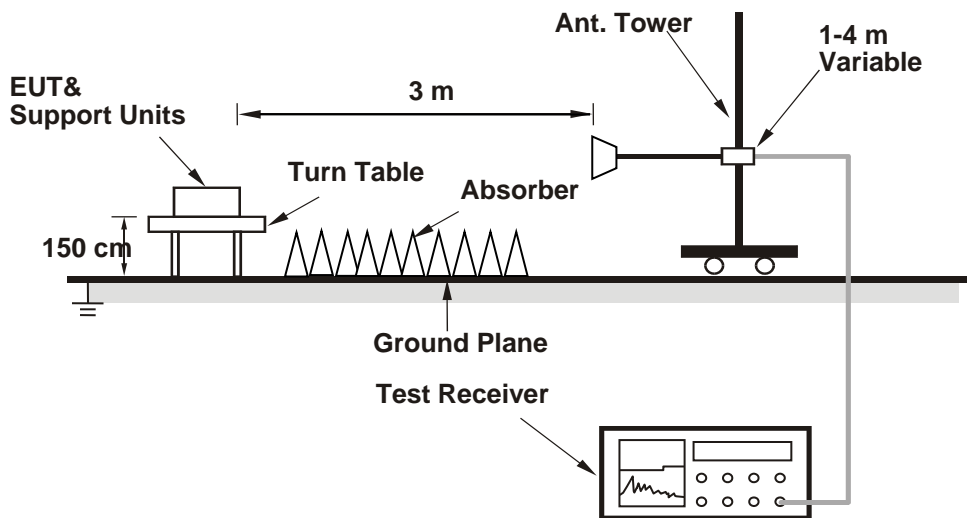

For the actual test configuration, please refer to the attached file (Test Setup Photo).



4.2.5 Test Results

**BELOW 1GHz**

**WCDMA VI**

<b>Mode</b>	TX channel 1312 (1712.4MHz)	<b>Frequency Range</b>	Below 1000 MHz
<b>Environmental Conditions</b>	25deg. C, 70%RH	<b>Input Power</b>	120Vac, 60Hz
<b>Tested By</b>	Noah Chang		

ANTENNA POLARITY & TEST DISTANCE: HORIZONTAL AT 3 M							
NO.	FREQ. (MHz)	READING (dBm)	S.G POWER VALUE (dBm)	CORRECTION FACTOR (dB)	EIRP (dBm)	LIMIT (dBm)	MARGIN (dB)
1	76.56	-44.8	-48.1	-2.8	-50.9	-13.0	-37.9
2	99.84	-40.9	-49.3	0.9	-48.4	-13.0	-35.4
3	136.70	-43.8	-49.8	-0.3	-50.1	-13.0	-37.1
4	522.76	-54.9	-60.6	4.8	-55.8	-13.0	-42.8
5	747.80	-54.1	-55.2	4.7	-50.5	-13.0	-37.5
6	939.86	-60.3	-57.1	3.9	-53.2	-13.0	-40.2

Remarks:

1. EIRP (dBm) = S.G Value (dBm) + Correction Factor (dB).
2. Correction Factor (dB) = Substitution Antenna Gain (dB) + Cable Loss (dB).

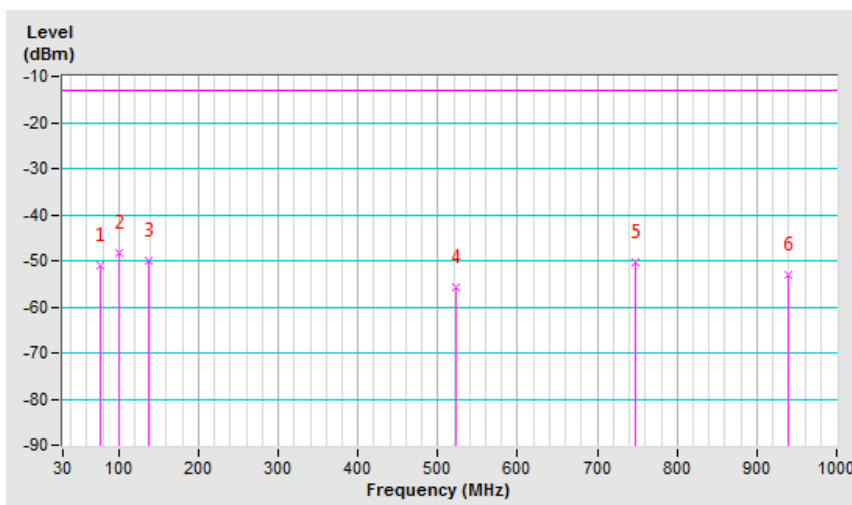

<b>Mode</b>	TX channel 1312 (1712.4MHz)	<b>Frequency Range</b>	Below 1000 MHz
<b>Environmental Conditions</b>	25deg. C, 70%RH	<b>Input Power</b>	120Vac, 60Hz
<b>Tested By</b>	Noah Chang		

ANTENNA POLARITY & TEST DISTANCE: VERTICAL AT 3 M							
NO.	FREQ. (MHz)	READING (dBm)	S.G POWER VALUE (dBm)	CORRECTION FACTOR (dB)	EIRP (dBm)	LIMIT (dBm)	MARGIN (dB)
1	33.88	-26.0	-23.9	-11.7	-35.6	-13.0	-22.6
2	70.74	-41.1	-42.2	-4.7	-46.9	-13.0	-33.9
3	235.64	-38.5	-43.6	5.4	-38.2	-13.0	-25.2
4	565.44	-47.7	-50.4	4.5	-45.9	-13.0	-32.9
5	747.80	-56.4	-55.5	4.7	-50.8	-13.0	-37.8
6	939.86	-60.2	-55.3	3.9	-51.4	-13.0	-38.4

Remarks:

1. EIRP (dBm) = S.G Value (dBm) + Correction Factor (dB).
2. Correction Factor (dB) = Substitution Antenna Gain (dB) + Cable Loss (dB).

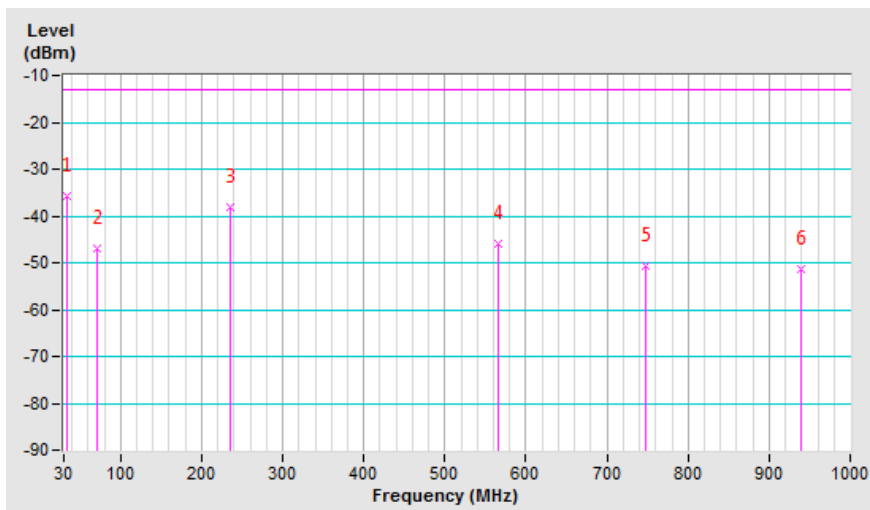

### LTE BAND 4, CHANNEL BANDWIDTH: 10MHz

<b>Mode</b>	TX channel 20350 (1750MHz)	<b>Frequency Range</b>	Below 1000 MHz
<b>Environmental Conditions</b>	25deg. C, 70%RH	<b>Input Power</b>	120Vac, 60Hz
<b>Tested By</b>	Noah Chang		

#### ANTENNA POLARITY & TEST DISTANCE: HORIZONTAL AT 3 M

NO.	FREQ. (MHz)	READING (dBm)	S.G POWER VALUE (dBm)	CORRECTION FACTOR (dB)	EIRP (dBm)	LIMIT (dBm)	MARGIN (dB)
1	45.52	-47.7	-36.3	-10.0	-46.3	-13.0	-33.3
2	78.50	-40.7	-44.2	-2.2	-46.4	-13.0	-33.4
<b>3</b>	<b>159.98</b>	<b>-30.9</b>	<b>-36.6</b>	<b>0.4</b>	<b>-36.2</b>	<b>-13.0</b>	<b>-23.2</b>
4	478.14	-54.6	-60.8	5.0	-55.8	-13.0	-42.8
5	730.34	-60.7	-62.3	4.9	-57.4	-13.0	-44.4
6	939.86	-59.4	-56.2	3.9	-52.3	-13.0	-39.3

Remarks:

1. EIRP (dBm) = S.G Value (dBm) + Correction Factor (dB).
2. Correction Factor (dB) = Substitution Antenna Gain (dB) + Cable Loss (dB).

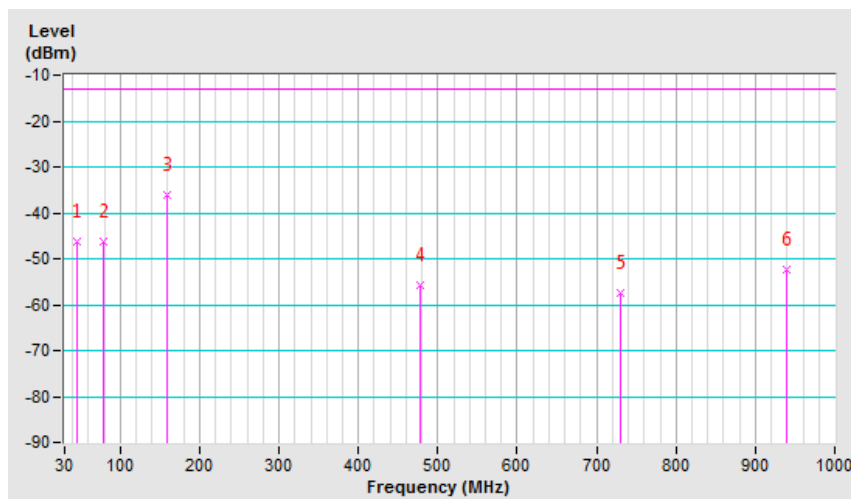

<b>Mode</b>	TX channel 20350 (1750MHz)	<b>Frequency Range</b>	Below 1000 MHz
<b>Environmental Conditions</b>	25deg. C, 70%RH	<b>Input Power</b>	120Vac, 60Hz
<b>Tested By</b>	Noah Chang		

ANTENNA POLARITY & TEST DISTANCE: VERTICAL AT 3 M							
NO.	FREQ. (MHz)	READING (dBm)	S.G POWER VALUE (dBm)	CORRECTION FACTOR (dB)	EIRP (dBm)	LIMIT (dBm)	MARGIN (dB)
1	45.52	-39.5	-35.9	-10.0	-45.9	-13.0	-32.9
2	68.80	-42.6	-43.4	-5.3	-48.7	-13.0	-35.7
3	88.20	-43.2	-48.6	0.6	-48.0	-13.0	-35.0
4	103.72	-46.0	-52.5	0.7	-51.8	-13.0	-38.8
5	730.34	-48.1	-47.3	4.9	-42.4	-13.0	-29.4
6	939.86	-56.9	-52.0	3.9	-48.1	-13.0	-35.1

Remarks:

1. EIRP (dBm) = S.G Value (dBm) + Correction Factor (dB).
2. Correction Factor (dB) = Substitution Antenna Gain (dB) + Cable Loss (dB).

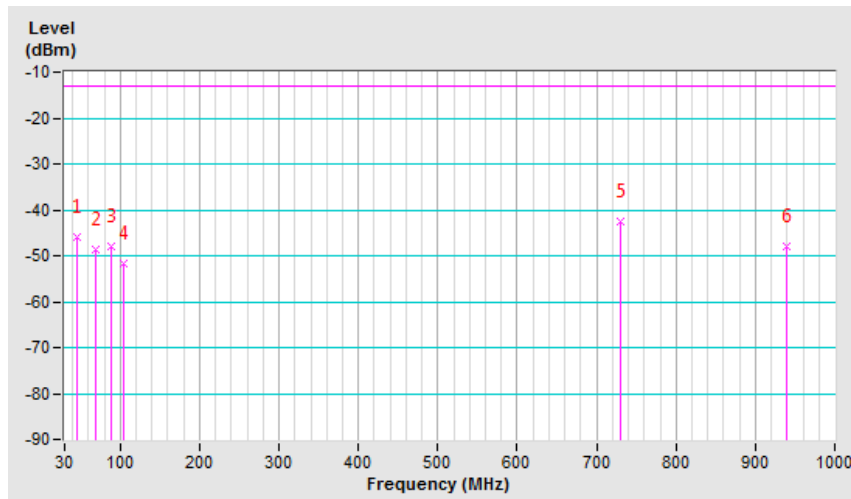

### LTE BAND 12, CHANNEL BANDWIDTH: 1.4MHz

<b>Mode</b>	TX channel 23173 (715.3MHz)	<b>Frequency Range</b>	Below 1000 MHz
<b>Environmental Conditions</b>	25deg. C, 70%RH	<b>Input Power</b>	120Vac, 60Hz
<b>Tested By</b>	Noah Chang		

ANTENNA POLARITY & TEST DISTANCE: HORIZONTAL AT 3 M							
NO.	FREQ. (MHz)	READING (dBm)	S.G POWER VALUE (dBm)	CORRECTION FACTOR (dB)	EIRP (dBm)	LIMIT (dBm)	MARGIN (dB)
1	82.38	-41.6	-47.1	-1.0	-48.1	-13.0	-35.1
2	161.92	-34.8	-41.3	0.7	-40.6	-13.0	-27.6
3	334.58	-50.2	-58.9	5.2	-53.7	-13.0	-40.7
4	730.34	-57.6	-59.2	4.9	-54.3	-13.0	-41.3
5	747.80	-57.5	-58.6	4.7	-53.9	-13.0	-40.9
6	939.86	-60.2	-57.0	3.9	-53.1	-13.0	-40.1

Remarks:

1. EIRP (dBm) = S.G Value (dBm) + Correction Factor (dB).
2. Correction Factor (dB) = Substitution Antenna Gain (dB) + Cable Loss (dB).

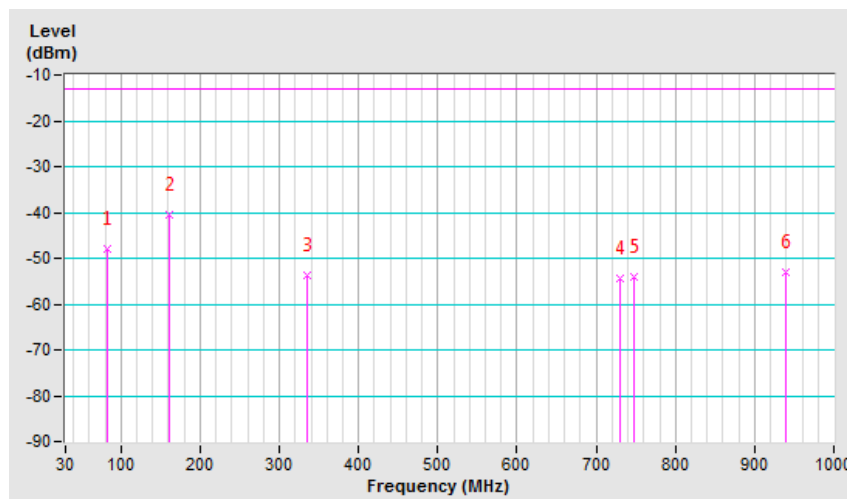

<b>Mode</b>	TX channel 23173 (715.3MHz)	<b>Frequency Range</b>	Below 1000 MHz
<b>Environmental Conditions</b>	25deg. C, 70%RH	<b>Input Power</b>	120Vac, 60Hz
<b>Tested By</b>	Noah Chang		

ANTENNA POLARITY & TEST DISTANCE: VERTICAL AT 3 M							
NO.	FREQ. (MHz)	READING (dBm)	S.G POWER VALUE (dBm)	CORRECTION FACTOR (dB)	EIRP (dBm)	LIMIT (dBm)	MARGIN (dB)
1	43.58	-43.0	-38.9	-10.3	-49.2	-13.0	-36.2
2	59.10	-40.4	-39.8	-7.8	-47.6	-13.0	-34.6
3	262.80	-56.6	-59.8	5.3	-54.5	-13.0	-41.5
4	350.10	-51.8	-58.5	5.2	-53.3	-13.0	-40.3
5	734.22	-53.5	-52.7	4.8	-47.9	-13.0	-34.9
6	939.86	-57.9	-53.0	3.9	-49.1	-13.0	-36.1

Remarks:

1. EIRP (dBm) = S.G Value (dBm) + Correction Factor (dB).
2. Correction Factor (dB) = Substitution Antenna Gain (dB) + Cable Loss (dB).

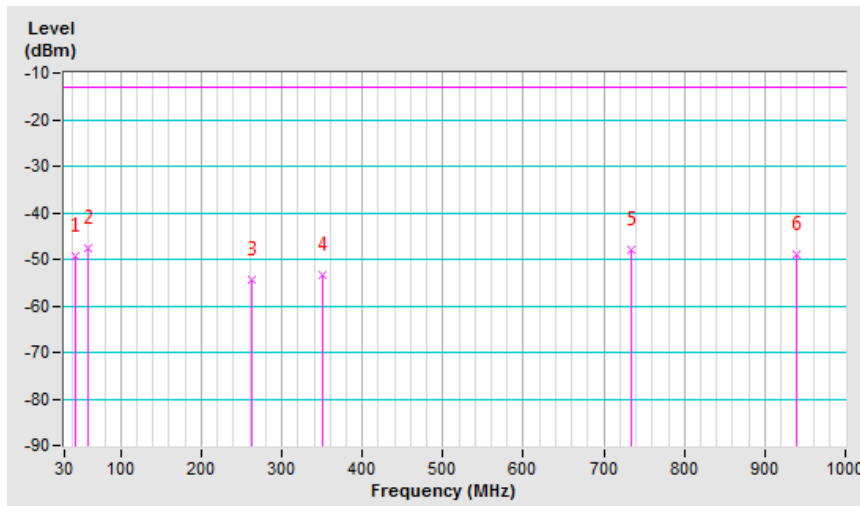

**Above 1GHz**
**WCDMA Band IV**

<b>Mode</b>	TX channel 1312 (1712.4MHz)	<b>Frequency Range</b>	1GHz-18GHz
<b>Environmental Conditions</b>	25deg. C, 70%RH	<b>Input Power</b>	120Vac, 60Hz
<b>Tested By</b>	Noah Chang		

**ANTENNA POLARITY & TEST DISTANCE: HORIZONTAL AT 3 M**

NO.	FREQ. (MHz)	READING (dBm)	S.G POWER VALUE (dBm)	CORRECTION FACTOR (dB)	EIRP (dBm)	LIMIT (dBm)	MARGIN (dB)
1	3424.80 (PK)	-64.5	-60.3	7.1	-53.2	-13.0	-40.2

**ANTENNA POLARITY & TEST DISTANCE: VERTICAL AT 3 M**

NO.	FREQ. (MHz)	READING (dBm)	S.G POWER VALUE (dBm)	CORRECTION FACTOR (dB)	EIRP (dBm)	LIMIT (dBm)	MARGIN (dB)
1	3424.80 (PK)	-66.9	-60.4	7.1	-53.3	-13.0	-40.3

Remarks:

1. EIRP (dBm) = S.G Value (dBm) + Correction Factor (dB).
2. Correction Factor (dB) = Substitution Antenna Gain (dB) + Cable Loss (dB).

**LTE Band 4, Channel Bandwidth 10MHz**

<b>Mode</b>	TX channel 20350 (1750MHz)	<b>Frequency Range</b>	1GHz-18GHz
<b>Environmental Conditions</b>	25deg. C, 70%RH	<b>Input Power</b>	120Vac, 60Hz
<b>Tested By</b>	Noah Chang		

**ANTENNA POLARITY & TEST DISTANCE: HORIZONTAL AT 3 M**

NO.	FREQ. (MHz)	READING (dBm)	S.G POWER VALUE (dBm)	CORRECTION FACTOR (dB)	EIRP (dBm)	LIMIT (dBm)	MARGIN (dB)
1	3500.00 (PK)	-65.6	-60.1	7.2	-52.9	-13.0	-39.9

**ANTENNA POLARITY & TEST DISTANCE: VERTICAL AT 3 M**

NO.	FREQ. (MHz)	READING (dBm)	S.G POWER VALUE (dBm)	CORRECTION FACTOR (dB)	EIRP (dBm)	LIMIT (dBm)	MARGIN (dB)
1	3500.00 (PK)	-69.3	-62.3	7.2	-55.1	-13.0	-42.1

Remarks:

1. EIRP (dBm) = S.G Value (dBm) + Correction Factor (dB).
2. Correction Factor (dB) = Substitution Antenna Gain (dB) + Cable Loss (dB).

**LTE Band 12, Channel Bandwidth 1.4MHz**

<b>Mode</b>	TX channel 23173 (715.3MHz)	<b>Frequency Range</b>	1GHz-18GHz
<b>Environmental Conditions</b>	25deg. C, 70%RH	<b>Input Power</b>	120Vac, 60Hz
<b>Tested By</b>	Noah Chang		

**ANTENNA POLARITY & TEST DISTANCE: HORIZONTAL AT 3 M**

NO.	FREQ. (MHz)	READING (dBm)	S.G POWER VALUE (dBm)	CORRECTION FACTOR (dB)	EIRP (dBm)	LIMIT (dBm)	MARGIN (dB)
1	1430.60 (PK)	-47.8	-47.6	4.8	-42.8	-13.0	-29.8

**ANTENNA POLARITY & TEST DISTANCE: VERTICAL AT 3 M**

NO.	FREQ. (MHz)	READING (dBm)	S.G POWER VALUE (dBm)	CORRECTION FACTOR (dB)	EIRP (dBm)	LIMIT (dBm)	MARGIN (dB)
1	1430.60 (PK)	-47.8	-47.4	4.8	-42.6	-13.0	-29.6

Remarks:

1. EIRP (dBm) = S.G Value (dBm) + Correction Factor (dB).
2. Correction Factor (dB) = Substitution Antenna Gain (dB) + Cable Loss (dB).



## 5 Pictures of Test Arrangements

Please refer to the attached file (Test Setup Photo).

## Appendix – Information of the Testing Laboratories

We, Bureau Veritas Consumer Products Services (H.K.) Ltd., Taoyuan Branch, were founded in 1988 to provide our best service in EMC, Radio, Telecom and Safety consultation. Our laboratories are FCC recognized accredited test firms and accredited according to ISO/IEC 17025.

If you have any comments, please feel free to contact us at the following:

**Lin Kou EMC/RF Lab**

Tel: 886-2-26052180

Fax: 886-2-26051924

**Hsin Chu EMC/RF/Telecom Lab**

Tel: 886-3-6668565

Fax: 886-3-6668323

**Hwa Ya EMC/RF/Safety Lab**

Tel: 886-3-3183232

Fax: 886-3-3270892

**Email:** [service.adt@tw.bureauveritas.com](mailto:service.adt@tw.bureauveritas.com)

**Web Site:** [www.bureauveritas-adt.com](http://www.bureauveritas-adt.com)

The address and road map of all our labs can be found in our web site also.

--- END ---