

FCC Test Report

(PART 22)

Report No.: RFBHAA-WTW-P20090611

FCC ID: JOYDA39

Test Model: AL-T51A2-2

Series Model: AL-T52V1, AL-T51A2-1 (refer to item 3.1 for more details)

Received Date: Sep. 26, 2020

Test Date: Sep. 29 ~ Oct. 06, 2020

Issued Date: Oct. 15, 2020

Applicant: Kyocera Corporation

Address: 2-1-1 Kagahara, Tsuzuki-ku Yokohama-city Kanagawa 224-8502 Japan

Issued By: Bureau Veritas Consumer Products Services (H.K.) Ltd., Taoyuan Branch
Lin Kou Laboratories

Lab Address: No. 47-2, 14th Ling, Chia Pau Vil., Lin Kou Dist., New Taipei City, Taiwan

Test Location: No. 19, Hwa Ya 2nd Rd., Wen Hwa Vil., Kwei Shan Dist., Taoyuan City
33383, Taiwan

**FCC Registration /
Designation Number:** 788550 / TW0003



This report is for your exclusive use. Any copying or replication of this report to or for any other person or entity, or use of our name or trademark, is permitted only with our prior written permission. This report sets forth our findings solely with respect to the test samples identified herein. The results set forth in this report are not indicative or representative of the quality or characteristics of the lot from which a test sample was taken or any similar or identical product specifically and expressly noted. Our report includes all of the tests requested by you and the results thereof based upon the information that you provided to us. You have 60 days from date of issuance of this report to notify us of any material error or omission caused by our negligence, provided, however, that such notice shall be in writing and shall specifically address the issue you wish to raise. A failure to raise such issue within the prescribed time shall constitute your unqualified acceptance of the completeness of this report, the tests conducted and the correctness of the report contents. Unless specific mention, the uncertainty of measurement has been explicitly taken into account to declare the compliance or non-compliance to the specification.

Table of Contents

Release Control Record	3
1 Certificate of Conformity	4
2 Summary of Test Results	5
2.1 Measurement Uncertainty.....	5
2.2 Test Site and Instruments	6
3 General Information	7
3.1 General Description of EUT.....	7
3.2 Configuration of System under Test.....	9
3.2.1 Description of Support Units.....	9
3.3 Test Mode Applicability and Tested Channel Detail	10
3.4 EUT Operating Conditions	10
3.5 General Description of Applied Standards and references	11
4 Test Types and Results	12
4.1 Output Power Measurement.....	12
4.1.1 Limits of Output Power Measurement	12
4.1.2 Test Procedures.....	12
4.1.3 Test Setup.....	13
4.1.4 Test Results	14
4.2 Radiated Emission Measurement.....	19
4.2.1 Limits of Radiated Emission Measurement	19
4.2.2 Test Procedure	19
4.2.3 Deviation from Test Standard	19
4.2.4 Test Setup.....	20
4.2.5 Test Results	21
5 Pictures of Test Arrangements	26
Appendix – Information of the Testing Laboratories	27

Release Control Record

Issue No.	Description	Date Issued
RFBHAA-WTW-P20090611	Original Release	Oct. 15, 2020

1 Certificate of Conformity

Product: Telematics Module

Brand: Kyocera

Test Model: AL-T51A2-2

Series Model: AL-T52V1, AL-T51A2-1 (refer to item 3.1 for more details)

Sample Status: Engineering Sample

Applicant: Kyocera Corporation

Test Date: Sep. 29 ~ Oct. 06, 2020

Standards: FCC Part 22, Subpart H

This report is issued as a supplementary report of RFBHAA-WTW-P20070391. This report shall be used combined together with its original report.

Prepared by : Pettie Chen , **Date:** Oct. 15, 2020
Pettie Chen / Senior Specialist

Approved by : Bruce Chen , **Date:** Oct. 15, 2020
Bruce Chen / Senior Project Engineer

2 Summary of Test Results

Applied Standard: FCC Part 22 & Part 2			
FCC Clause	Test Item	Result	Remarks
2.1046 22.913 (a)	Effective Radiated Power	Pass	Meet the requirement of limit.
2.1047	Modulation Characteristics	N/A	Refer to Note 1
22.913 (d)	Peak to Average Ratio	N/A	Refer to Note 1
2.1055 22.355	Frequency Stability	N/A	Refer to Note 1
2.1049	Occupied Bandwidth	N/A	Refer to Note 1
22.917	Band Edge Measurements	N/A	Refer to Note 1
2.1051 22.917	Conducted Spurious Emissions	N/A	Refer to Note 1
2.1053 22.917	Radiated Spurious Emissions	Pass	Meet the requirement of limit. Minimum passing margin is -29.8 dB at 125.06 MHz.

N/A: Not Applicable

Note:

1. The effective radiated power and radiated spurious emissions test items are performed for the addendum, according to the worst case of the original report. Refer to original report for the other test data.
2. Determining compliance based on the results of the compliance measurement, not taking into account measurement instrumentation uncertainty.

2.1 Measurement Uncertainty

Where relevant, the following measurement uncertainty levels have been estimated for tests performed on the EUT as specified in CISPR 16-4-2:

Measurement	Frequency	Expanded Uncertainty (k=2) (±)
Radiated Emissions up to 1 GHz	9 kHz ~ 30 MHz	3.04 dB
	30 MHz ~ 200 MHz	3.63 dB
	200 MHz ~ 1000 MHz	3.64 dB
Radiated Emissions above 1 GHz	1 GHz ~ 18 GHz	2.29 dB
	18 GHz ~ 40 GHz	2.29 dB

2.2 Test Site and Instruments

Description & Manufacturer	Model No.	Serial No.	Date of Calibration	Due Date of Calibration
Test Receiver ROHDE & SCHWARZ	ESCI	100424	Dec. 31, 2019	Dec. 30, 2020
Spectrum Analyzer ROHDE & SCHWARZ	FSP40	100040	Sep. 16, 2020	Sep. 15, 2021
BILOG Antenna SCHWARZBECK	VULB9168	9168-155	Nov. 11, 2019	Nov. 10, 2020
HORN Antenna SCHWARZBECK	BBHA 9120D	9120D-1170	Nov. 24, 2019	Nov. 23, 2020
HORN Antenna SCHWARZBECK	BBHA 9170	BBHA9170241	Nov. 24, 2019	Nov. 23, 2020
Preamplifier Agilent (Below 1GHz)	8447D	2944A10631	Jun. 08, 2020	Jun. 07, 2021
Preamplifier KEYSIGHT (Above 1GHz)	83017A	MY53270295	Jun. 08, 2020	Jun. 07, 2021
RF Coaxial Cable WOKEN With 5dB PAD	8D-FB	Cable-CH4-01	Aug. 16, 2020	Aug. 15, 2021
RF Coaxial Cable EMCI	EMC102-KM-KM-3000	150929	Aug. 16, 2020	Aug. 15, 2021
RF Coaxial Cable EMCI	EMC102-KM-KM-600	150928	Aug. 16, 2020	Aug. 15, 2021
RF signal cable HUBER+SUHNER	SUCOFLEX 104	MY 13380+295012/04	Jun. 08, 2020	Jun. 07, 2021
RF signal cable HUBER+SUHNER	SUCOFLEX 104	Cable-CH4-03 (250724)	Jun. 08, 2020	Jun. 07, 2021
Software BV ADT	ADT_Radiated_ V7.6.15.9.5	NA	NA	NA
Antenna Tower inn-co GmbH	MA 4000	010303	NA	NA
Antenna Tower Controller BV ADT	AT100	AT93021703	NA	NA
Turn Table BV ADT	TT100	TT93021703	NA	NA
Turn Table Controller BV ADT	SC100	SC93021703	NA	NA
Boresight Antenna Fixture	FBA-01	FBA-SIP01	NA	NA
Pre-amplifier (18GHz-40GHz) EMC	EMC184045B	980175	Sep. 04, 2020	Sep. 03, 2021
JFW 20dB attenuation	50HF-020-SMA	NA	NA	NA

- Note: 1. The calibration interval of the above test instruments is 12 months and the calibrations are traceable to NML/ROC and NIST/USA.
 2. The test was performed in HwaYa Chamber 4.

3 General Information

3.1 General Description of EUT

Product	Telematics Module	
Brand	Kyocera	
Test Model	AL-T51A2-2	
Series Model	AL-T52V1, AL-T51A2-1	
Status of EUT	Engineering Sample	
Power Supply Rating	5Vdc	
Modulation Type	WCDMA	BPSK, QPSK
	LTE	QPSK, 16QAM
Frequency Range	WCDMA Band 5	826.4 ~ 846.6 MHz
	LTE Band 26 (Channel Bandwidth: 1.4 MHz)	824.7 ~ 848.3 MHz
	LTE Band 26 (Channel Bandwidth: 3 MHz)	825.5 ~ 847.5 MHz
	LTE Band 26 (Channel Bandwidth: 5 MHz)	826.5 ~ 846.5 MHz
	LTE Band 26 (Channel Bandwidth: 10 MHz)	829 ~ 844 MHz
	LTE Band 26 (Channel Bandwidth: 15 MHz)	831.5 ~ 841.5 MHz
Max. ERP Power	WCDMA Band 5	50.119 mW (17.00dBm)
	LTE Band 26 (Channel Bandwidth: 1.4 MHz)	151.356 mW (21.80dBm)
	LTE Band 26 (Channel Bandwidth: 3 MHz)	138.038 mW (21.40dBm)
	LTE Band 26 (Channel Bandwidth: 5 MHz)	128.825 mW (21.10dBm)
	LTE Band 26 (Channel Bandwidth: 10 MHz)	120.226 mW (20.80dBm)
	LTE Band 26 (Channel Bandwidth: 15 MHz)	125.893 mW (21.00dBm)
Antenna Type	Refer to Note as below	
Accessory Device	Refer to Note as below	
Data Cable Supplied	Refer to Note as below	

Note:

1. This report is prepared for FCC class II permissive change. The differences compared with the original report (BV CPS report no.: RFBHAA-WTW-P20070391) are adding a model and changing software & memory capacity. The effective radiated power and radiated spurious emissions test items are performed for the addendum, according to the worst case of the original report. Refer to original report for the other test data.
2. All models are listed as below. (New model is marked in boldface.)

Brand	Model	Difference
Kyocera	AL-T52V1	Support WCDMA Band 2, 4, 5 and LTE Band 2, 4, 5, 12, 13
	AL-T51A2-1	Support WCDMA Band 2, 4, 5 and LTE Band 2, 4, 5, 12
	AL-T51A2-2	Support band same with AL-T51A2-1, just different memory and driver software

3. The EUT uses following antennas (support units).

Antenna 1					
Antenna Type	AUX		Connector Type		SMA
Manufacturer	YOKOWO		Part Number		86769-459B1
Band	B12	B13	B5 / B26	B4	B2
Frequency (MHz)	704	782	832	1730	1880
Gain (dBi)	3.1	3.2	3.8	2.6	2.0

Antenna 2					
Antenna Type	AUX		Connector Type		SMA
Manufacturer	taoglas		Part Number		TG.30.8113
Band	B12	B5 / B26		B4	B2
Frequency (MHz)	700-800	824-960		1710-1880	1850-1990
Free Space Straight Gain (dBi)	1.1	0.3		1.9	2.7
Free Space Bent Gain (dBi)	2.6	1.5		2.7	3.1

Antenna 3					
Antenna Type	AUX		Connector Type		Inverted-F
Manufacturer	MinebeaMitsumi		Part Number		DN4E 66T30
Band	B12 / B13		B5 / B26	B4	B2
Frequency (MHz)	700-800		824-960	1710-1880	1850-1990
Gain (dBd)	-0.3		-0.3	0.4	0.4
Gain (dBi)	1.85		1.85	2.55	2.55

dBi = dBd + 2.15

Antenna 4					
Antenna Type	External		Connector Type		Inverted-F
Manufacturer	Mitsumi Electric		Part Number		KJK966 T30
Band	B12 / B13		B5 / B26	B4	B2
Frequency (MHz)	700-800		824-960	1710-1880	1850-1990
Gain (dBi)	1.0		1.0	0.4	0.4

Antenna 5					
Antenna Type	External		Connector Type		Inverted-F
Manufacturer	HARADA INDUSTRY		Part Number		TD2K 66 T30
Band	B12 / B13		B5 / B26	B4	B2
Frequency (MHz)	700-800		824-960	1710-1880	1850-1990
Gain (dBi)	-2.1		-2.1	-1.2	-1.2

For WCDMA Band 2 and LTE Band 2: Antenna 2 was chosen for final test according to manufacturer's requirement.

For WCDMA Band 4, 5 and LTE Band 4, 5, 12, 13, 26: Antenna 1 was chosen for final test according to manufacturer's requirement.

4. The above Antenna information is declared by manufacturer and for more detailed features description, please refer to the manufacturer's specifications, the laboratory shall not be held responsible

3.2 Configuration of System under Test

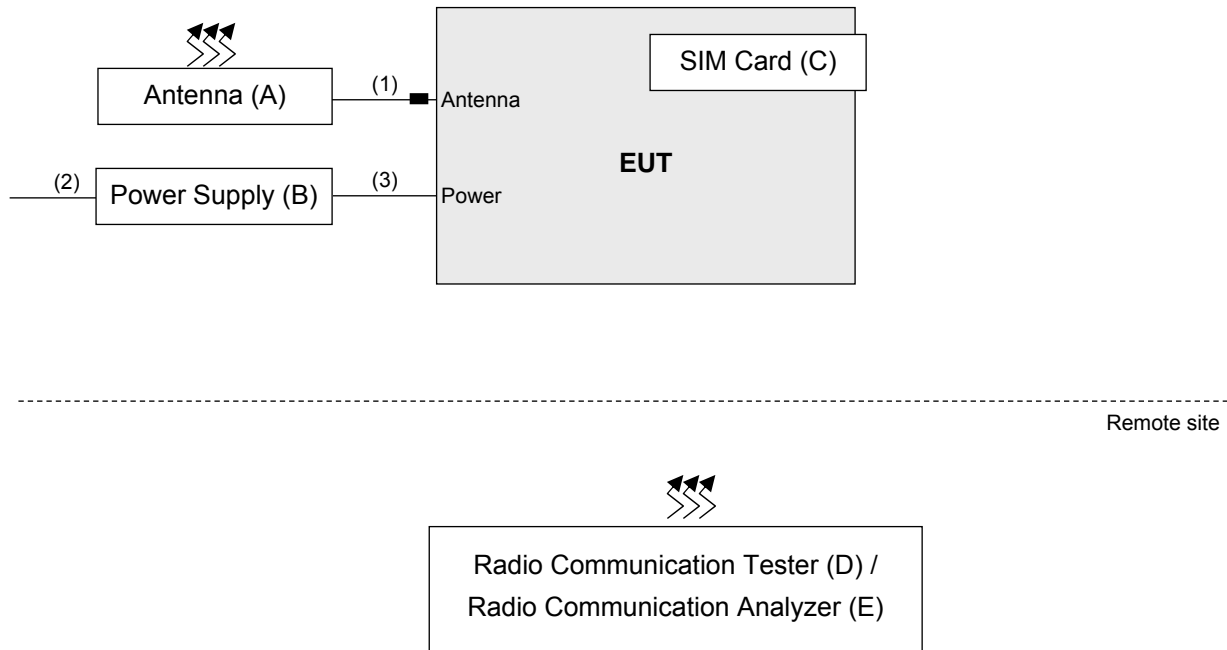

3.2.1 Description of Support Units

The EUT has been tested as an independent unit together with other necessary accessories or support units. The following support units or accessories were used to form a representative test configuration during the tests.

ID	Product	Brand	Model No.	Serial No.	FCC ID	Remarks
A.	Antenna	taoglas	TG.30.8113	NA	NA	Provided by manufacturer
B.	Power Supply	Inspower	DC400-20D	212004	FCC DoC Approved	Provided by manufacturer Input: 100-240Vac, 0.4A, 50-60Hz Output: 5Vdc, 3A
C.	SIM Card	NA	NA	NA	NA	Provided by manufacturer
D.	Radio Communication Tester	R&S	CMU200	123112	NA	-
E.	Radio Communication Analyzer	Anritsu	MT8820C	6201300640	NA	-

Note:

1. All power cords of the above support units are non-shielded (1.8m).
2. Item D and E acted as a communication partners to transfer data.

ID	Descriptions	Qty.	Length (m)	Shielding (Yes/No)	Cores (Qty.)	Remarks
1.	Antenna	1	3	N	1	Provided by manufacturer
2.	Power	1	1.75	N	0	Provided by manufacturer
3.	Module cable	2	0.08	N	0	Attached on EUT

Note: The core(s) is(are) originally attached to the cable(s).

3.3 Test Mode Applicability and Tested Channel Detail

Pre-Scan has been conducted to determine the worst-case mode from all possible combinations between available modulations, data rates, XYZ axis and antenna ports. The worst case was found when positioned on Z-plane. Following channel(s) was (were) selected for the final test as listed below.

WCDMA Band 5

EUT Configure Mode	Test Item	Available Channel	Tested Channel	Mode
-	ERP	4132 to 4233	4132 (826.4MHz), 4182 (836.4MHz), 4233 (846.6MHz)	WCDMA
-	Radiated Emission	4132 to 4233	4182 (836.4MHz)	WCDMA

LTE Band 26

EUT Configure Mode	Test Item	Available Channel	Tested Channel	Channel Bandwidth	Modulation	Mode
-	ERP	26797 to 27033	26797 (824.7MHz), 26915 (836.5MHz), 27033 (848.3MHz)	1.4MHz	QPSK	1 RB / 0 RB Offset
		26805 to 27025	26805 (825.5MHz), 26915 (836.5MHz), 27025 (847.5MHz)	3MHz	QPSK	1 RB / 0 RB Offset
		26815 to 27015	26815 (826.5MHz), 26915 (836.5MHz), 27015 (846.5MHz)	5MHz	QPSK	1 RB / 0 RB Offset
		26840 to 26990	26840 (829MHz), 26915 (836.5MHz), 26990 (844MHz)	10MHz	QPSK	1 RB / 0 RB Offset
		26865 to 26965	26865 (831.5MHz), 26965 (841.5MHz)	15MHz	QPSK	1 RB / 0 RB Offset
-	Radiated Emission	26797 to 27033	26797 (824.7MHz)	1.4 MHz	QPSK	1 RB / 0 RB Offset

Test Condition:

Test Item	Environmental Conditions	Input Power	Tested By
ERP	25deg. C, 70%RH	120Vac, 60Hz	Luis Lee
Radiated Emission	25deg. C, 70%RH	120Vac, 60Hz	Noah Chang

3.4 EUT Operating Conditions

The EUT makes a call to the communication simulator. The communication simulator station system controlled a EUT to export maximum output power under transmission mode and specific channel frequency.

3.5 General Description of Applied Standards and references

The EUT is a RF Product. According to the specifications of the manufacturer, it must comply with the requirements of the following standards and references:

Test Standard:

FCC 47 CFR Part 2

FCC 47 CFR Part 22

ANSI 63.26-2015

Note: All test items have been performed and recorded as per the above standards.

References Test Guidance:

KDB 971168 D01 Power Meas License Digital Systems v03r01

ANSI/TIA/EIA-603-E 2016

Note: All test items have been performed as a reference to the above KDB test guidance.

4 Test Types and Results

4.1 Output Power Measurement

4.1.1 Limits of Output Power Measurement

Mobile / Portable station are limited to 7 watts e.r.p.

4.1.2 Test Procedures

EIRP / ERP Measurement:

- a. All measurements were done at low, middle and high operational frequency range. RBW is 5MHz for WCDMA mode, 20MHz for LTE mode, and VBW $\geq 3 \times$ RBW.
- b. Substitution method is used for E.I.R.P measurement. In the semi-anechoic chamber, EUT placed on the 0.8m(below or equal 1GHz) and/or 1.5m(above 1GHz) height of Turn Table, rotated the table around 360 degrees to search the maximum radiation power and receiver antenna shall be rotated vertical and horizontal polarization and moved height from 1m to 4m to find the maximum polar radiated power. The "Read Value" is the spectrum reading the maximum power value.
- c. The substitution horn antenna is substituted for EUT at the same position and signals generator export the CW signal to the substitution antenna via a TX cable. Rotated the Turn Table and moved receiving antenna to find the maximum radiation power. Adjust output power level of S.G to get a Value of spectrum reading equal to "Read Value" of step b. Record the power level of S.G
- d. EIRP = Output power level of S.G – TX cable loss + Antenna gain of substitution horn.E.R.P power can be calculated form E.I.R.P power by subtracting the gain of dipole, E.R.P power = E.I.R.P power - 2.15dBi.

Where:

$$\text{ERP/EIRP} = P_{\text{Meas}} + G_T - L_C$$

P_{Meas} : Measure transmitter output power.

G_T : Gain of the transmitting antenna.

L_C : signal attenuation in the connecting cable between the transmitter and antenna.

4.1.3 Test Setup

**EIRP / ERP Measurement:
<Radiated Emission below or equal 1 GHz>**

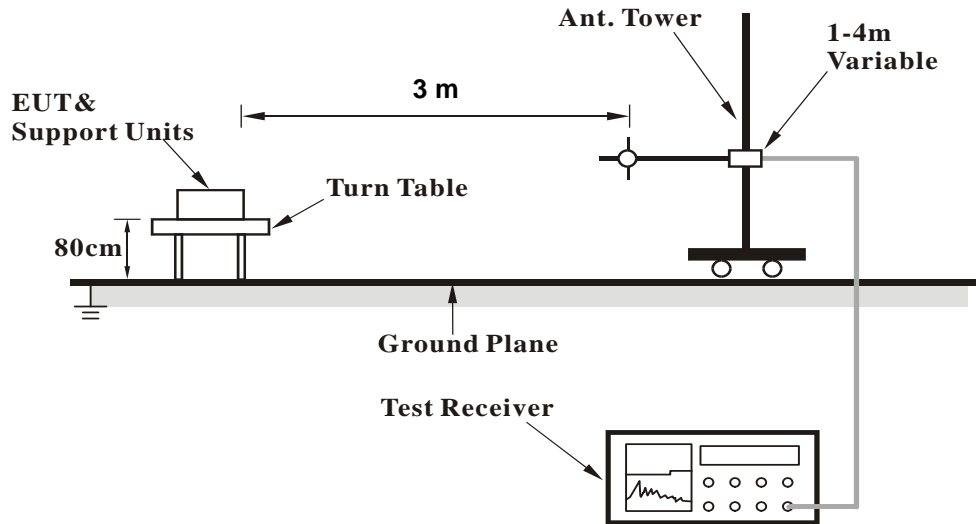

<Radiated Emission above 1 GHz>

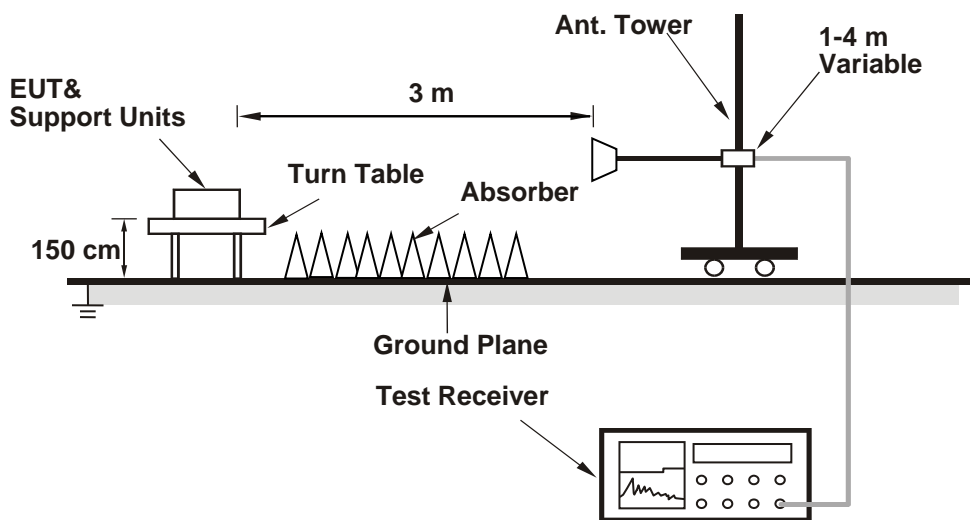

For the actual test configuration, please refer to the attached file (Test Setup Photo).

4.1.4 Test Results

ERP Power (dBm)

WCDMA Band V

ANTENNA POLARITY & TEST DISTANCE: HORIZONTAL AT 3 M							
Channel	FREQ. (MHz)	READING (dBm)	S.G POWER VALUE (dBm)	CORRECTION FACTOR (dB)	ERP (dBm)	LIMIT (dBm)	MARGIN (dB)
4132	826.40	-15.6	15.5	0.0	15.5	38.5	-23.0
4182	836.40	-16.2	14.9	0.2	15.1	38.5	-23.4
4233	846.60	-16.9	13.6	0.4	14.0	38.5	-24.5
ANTENNA POLARITY & TEST DISTANCE: VERTICAL AT 3 M							
Channel	FREQ. (MHz)	READING (dBm)	S.G POWER VALUE (dBm)	CORRECTION FACTOR (dB)	ERP (dBm)	LIMIT (dBm)	MARGIN (dB)
4132	826.40	-15.0	16.9	0.0	16.9	38.5	-21.6
4182	836.40	-15.0	16.8	0.2	17.0	38.5	-21.5
4233	846.60	-15.2	16.0	0.4	16.4	38.5	-22.1

NOTE: Power Value(dBm) = S.G Power Value(dBm) + Correction Factor(dB)

QPSK

LTE Band 26, Channel Bandwidth 1.4MHz

ANTENNA POLARITY & TEST DISTANCE: HORIZONTAL AT 3 M							
Channel	FREQ. (MHz)	READING (dBm)	S.G POWER VALUE (dBm)	CORRECTION FACTOR (dB)	ERP (dBm)	LIMIT (dBm)	MARGIN (dB)
26797	824.70	-9.3	21.8	0.0	21.8	38.5	-16.7
26915	836.50	-11.1	20.1	0.2	20.3	38.5	-18.2
27033	848.30	-10.0	20.5	0.5	21.0	38.5	-17.5
ANTENNA POLARITY & TEST DISTANCE: VERTICAL AT 3 M							
Channel	FREQ. (MHz)	READING (dBm)	S.G POWER VALUE (dBm)	CORRECTION FACTOR (dB)	ERP (dBm)	LIMIT (dBm)	MARGIN (dB)
26797	824.70	-17.4	14.5	0.0	14.5	38.5	-24.0
26915	836.50	-18.9	12.9	0.2	13.1	38.5	-25.4
27033	848.30	-18.9	12.5	0.5	13.0	38.5	-25.5

NOTE: Power Value(dBm) = S.G Power Value(dBm) + Correction Factor(dB)

LTE Band 26, Channel Bandwidth 3MHz

ANTENNA POLARITY & TEST DISTANCE: HORIZONTAL AT 3 M							
Channel	FREQ. (MHz)	READING (dBm)	S.G POWER VALUE (dBm)	CORRECTION FACTOR (dB)	ERP (dBm)	LIMIT (dBm)	MARGIN (dB)
26805	825.50	-9.8	21.4	0.0	21.4	38.5	-17.1
26915	836.50	-11.0	20.2	0.2	20.4	38.5	-18.1
27025	847.50	-10.3	20.3	0.4	20.7	38.5	-17.8
ANTENNA POLARITY & TEST DISTANCE: VERTICAL AT 3 M							
Channel	FREQ. (MHz)	READING (dBm)	S.G POWER VALUE (dBm)	CORRECTION FACTOR (dB)	ERP (dBm)	LIMIT (dBm)	MARGIN (dB)
26805	825.50	-17.7	14.2	0.0	14.2	38.5	-24.3
26915	836.50	-18.6	13.2	0.2	13.4	38.5	-25.1
27025	847.50	-18.4	13.0	0.4	13.4	38.5	-25.1

NOTE: Power Value(dBm) = S.G Power Value(dBm) + Correction Factor(dB)

LTE Band 26, Channel Bandwidth 5MHz

ANTENNA POLARITY & TEST DISTANCE: HORIZONTAL AT 3 M							
Channel	FREQ. (MHz)	READING (dBm)	S.G POWER VALUE (dBm)	CORRECTION FACTOR (dB)	ERP (dBm)	LIMIT (dBm)	MARGIN (dB)
26815	826.50	-10.3	20.8	0.0	20.8	38.5	-17.7
26915	836.50	-10.2	20.9	0.2	21.1	38.5	-17.4
27015	846.50	-10.5	20.0	0.4	20.4	38.5	-18.1
ANTENNA POLARITY & TEST DISTANCE: VERTICAL AT 3 M							
Channel	FREQ. (MHz)	READING (dBm)	S.G POWER VALUE (dBm)	CORRECTION FACTOR (dB)	ERP (dBm)	LIMIT (dBm)	MARGIN (dB)
26815	826.50	-18.6	13.3	0.0	13.3	38.5	-25.2
26915	836.50	-18.6	13.2	0.2	13.4	38.5	-25.1
27015	846.50	-18.5	12.7	0.4	13.1	38.5	-25.4

NOTE: Power Value(dBm) = S.G Power Value(dBm) + Correction Factor(dB)

LTE Band 26, Channel Bandwidth 10MHz

ANTENNA POLARITY & TEST DISTANCE: HORIZONTAL AT 3 M							
Channel	FREQ. (MHz)	READING (dBm)	S.G POWER VALUE (dBm)	CORRECTION FACTOR (dB)	ERP (dBm)	LIMIT (dBm)	MARGIN (dB)
26840	829.00	-10.5	20.5	0.1	20.6	38.5	-17.9
26915	836.50	-10.6	20.6	0.2	20.8	38.5	-17.7
26990	844.00	-10.3	20.3	0.4	20.7	38.5	-17.8
ANTENNA POLARITY & TEST DISTANCE: VERTICAL AT 3 M							
Channel	FREQ. (MHz)	READING (dBm)	S.G POWER VALUE (dBm)	CORRECTION FACTOR (dB)	ERP (dBm)	LIMIT (dBm)	MARGIN (dB)
26840	829.00	-18.2	13.5	0.1	13.6	38.5	-24.9
26915	836.50	-19.0	12.8	0.2	13.0	38.5	-25.5
26990	844.00	-18.7	12.8	0.4	13.2	38.5	-25.3

NOTE: Power Value(dBm) = S.G Power Value(dBm) + Correction Factor(dB)

LTE Band 26, Channel Bandwidth 15MHz

ANTENNA POLARITY & TEST DISTANCE: HORIZONTAL AT 3 M							
Channel	FREQ. (MHz)	READING (dBm)	S.G POWER VALUE (dBm)	CORRECTION FACTOR (dB)	ERP (dBm)	LIMIT (dBm)	MARGIN (dB)
26865	831.50	-10.1	20.9	0.1	21.0	38.5	-17.5
26915	836.50	-11.0	20.2	0.2	20.4	38.5	-18.1
26965	841.50	-10.5	20.3	0.3	20.6	38.5	-17.9
ANTENNA POLARITY & TEST DISTANCE: VERTICAL AT 3 M							
Channel	FREQ. (MHz)	READING (dBm)	S.G POWER VALUE (dBm)	CORRECTION FACTOR (dB)	ERP (dBm)	LIMIT (dBm)	MARGIN (dB)
26865	831.50	-18.1	13.6	0.1	13.7	38.5	-24.8
26915	836.50	-18.5	13.3	0.2	13.5	38.5	-25.0
26965	841.50	-18.7	12.9	0.3	13.2	38.5	-25.3

NOTE: Power Value(dBm) = S.G Power Value(dBm) + Correction Factor(dB)

16QAM

LTE Band 26, Channel Bandwidth 1.4MHz

ANTENNA POLARITY & TEST DISTANCE: HORIZONTAL AT 3 M							
Channel	FREQ. (MHz)	READING (dBm)	S.G POWER VALUE (dBm)	CORRECTION FACTOR (dB)	ERP (dBm)	LIMIT (dBm)	MARGIN (dB)
26797	824.70	-10.3	20.8	0.0	20.8	38.5	-17.7
26915	836.50	-12.1	19.1	0.2	19.3	38.5	-19.2
27033	848.30	-11.0	19.5	0.5	20.0	38.5	-18.5
ANTENNA POLARITY & TEST DISTANCE: VERTICAL AT 3 M							
Channel	FREQ. (MHz)	READING (dBm)	S.G POWER VALUE (dBm)	CORRECTION FACTOR (dB)	ERP (dBm)	LIMIT (dBm)	MARGIN (dB)
26797	824.70	-18.4	13.5	0.0	13.5	38.5	-25.0
26915	836.50	-19.9	11.9	0.2	12.1	38.5	-26.4
27033	848.30	-19.9	11.5	0.5	12.0	38.5	-26.5

NOTE: Power Value(dBm) = S.G Power Value(dBm) + Correction Factor(dB)

LTE Band 26, Channel Bandwidth 3MHz

ANTENNA POLARITY & TEST DISTANCE: HORIZONTAL AT 3 M							
Channel	FREQ. (MHz)	READING (dBm)	S.G POWER VALUE (dBm)	CORRECTION FACTOR (dB)	ERP (dBm)	LIMIT (dBm)	MARGIN (dB)
26805	825.50	-10.8	20.4	0.0	20.4	38.5	-18.1
26915	836.50	-12.0	19.2	0.2	19.4	38.5	-19.1
27025	847.50	-11.3	19.3	0.4	19.7	38.5	-18.8
ANTENNA POLARITY & TEST DISTANCE: VERTICAL AT 3 M							
Channel	FREQ. (MHz)	READING (dBm)	S.G POWER VALUE (dBm)	CORRECTION FACTOR (dB)	ERP (dBm)	LIMIT (dBm)	MARGIN (dB)
26805	825.50	-18.7	13.2	0.0	13.2	38.5	-25.3
26915	836.50	-19.6	12.2	0.2	12.4	38.5	-26.1
27025	847.50	-19.4	12.0	0.4	12.4	38.5	-26.1

NOTE: Power Value(dBm) = S.G Power Value(dBm) + Correction Factor(dB)

LTE Band 26, Channel Bandwidth 5MHz

ANTENNA POLARITY & TEST DISTANCE: HORIZONTAL AT 3 M							
Channel	FREQ. (MHz)	READING (dBm)	S.G POWER VALUE (dBm)	CORRECTION FACTOR (dB)	ERP (dBm)	LIMIT (dBm)	MARGIN (dB)
26815	826.50	-11.3	19.8	0.0	19.8	38.5	-18.7
26915	836.50	-11.2	19.9	0.2	20.1	38.5	-18.4
27015	846.50	-11.5	19.0	0.4	19.4	38.5	-19.1
ANTENNA POLARITY & TEST DISTANCE: VERTICAL AT 3 M							
Channel	FREQ. (MHz)	READING (dBm)	S.G POWER VALUE (dBm)	CORRECTION FACTOR (dB)	ERP (dBm)	LIMIT (dBm)	MARGIN (dB)
26815	826.50	-19.6	12.3	0.0	12.3	38.5	-26.2
26915	836.50	-19.6	12.2	0.2	12.4	38.5	-26.1
27015	846.50	-19.5	11.7	0.4	12.1	38.5	-26.4

NOTE: Power Value(dBm) = S.G Power Value(dBm) + Correction Factor(dB)

LTE Band 26, Channel Bandwidth 10MHz

ANTENNA POLARITY & TEST DISTANCE: HORIZONTAL AT 3 M							
Channel	FREQ. (MHz)	READING (dBm)	S.G POWER VALUE (dBm)	CORRECTION FACTOR (dB)	ERP (dBm)	LIMIT (dBm)	MARGIN (dB)
26840	829.00	-11.5	19.5	0.1	19.6	38.5	-18.9
26915	836.50	-11.6	19.6	0.2	19.8	38.5	-18.7
26990	844.00	-11.3	19.3	0.4	19.7	38.5	-18.8
ANTENNA POLARITY & TEST DISTANCE: VERTICAL AT 3 M							
Channel	FREQ. (MHz)	READING (dBm)	S.G POWER VALUE (dBm)	CORRECTION FACTOR (dB)	ERP (dBm)	LIMIT (dBm)	MARGIN (dB)
26840	829.00	-19.2	12.5	0.1	12.6	38.5	-25.9
26915	836.50	-20.0	11.8	0.2	12.0	38.5	-26.5
26990	844.00	-19.7	11.8	0.4	12.2	38.5	-26.3

NOTE: Power Value(dBm) = S.G Power Value(dBm) + Correction Factor(dB)

LTE Band 26, Channel Bandwidth 15MHz

ANTENNA POLARITY & TEST DISTANCE: HORIZONTAL AT 3 M							
Channel	FREQ. (MHz)	READING (dBm)	S.G POWER VALUE (dBm)	CORRECTION FACTOR (dB)	ERP (dBm)	LIMIT (dBm)	MARGIN (dB)
26865	831.50	-11.1	19.9	0.1	20.0	38.5	-18.5
26915	836.50	-12.0	19.2	0.2	19.4	38.5	-19.1
26965	841.50	-11.5	19.3	0.3	19.6	38.5	-18.9
ANTENNA POLARITY & TEST DISTANCE: VERTICAL AT 3 M							
Channel	FREQ. (MHz)	READING (dBm)	S.G POWER VALUE (dBm)	CORRECTION FACTOR (dB)	ERP (dBm)	LIMIT (dBm)	MARGIN (dB)
26865	831.50	-19.1	12.6	0.1	12.7	38.5	-25.8
26915	836.50	-19.5	12.3	0.2	12.5	38.5	-26.0
26965	841.50	-19.7	11.9	0.3	12.2	38.5	-26.3

NOTE: Power Value(dBm) = S.G Power Value(dBm) + Correction Factor(dB)

4.2 Radiated Emission Measurement

4.2.1 Limits of Radiated Emission Measurement

The power of any emission outside of the authorized operating frequency ranges must be attenuated below the transmitting power (P) by a factor of at least $43 + 10 \log(P)$ dB. The emission limit is equal to -13 dBm.

4.2.2 Test Procedure

- a. Substitution method is used for E.I.R.P measurement. In the semi-anechoic chamber, EUT placed on the 0.8 m (below or equal 1 GHz) and/or 1.5 m (above 1 GHz) height of Turn Table, rotated the table around 360 degrees to search the maximum radiation power and receiver antenna shall be rotated vertical and horizontal polarization and moved height from 1 m to 4 m to find the maximum polar radiated power. The "Read Value" is the spectrum reading the maximum power value.
- b. The substitution horn antenna is substituted for EUT at the same position and signals generator export the CW signal to the substitution antenna via a TX cable. Rotated the Turn Table and moved receiving antenna to find the maximum radiation power. Adjust output power level of S.G to get a Value of spectrum reading equal to "Read Value" of step a. Record the power level of S.G
- c. EIRP = Output power level of S.G – TX cable loss + Antenna gain of substitution horn.
- d. E.R.P power can be calculated form E.I.R.P power by subtracting the gain of dipole, E.R.P power = E.I.R.P power - 2.15 dB.

NOTE: The resolution bandwidth and video bandwidth of test receiver/spectrum analyzer is 1 MHz/3 MHz.

4.2.3 Deviation from Test Standard

No deviation.

4.2.4 Test Setup

<Radiated Emission below or equal 1 GHz>

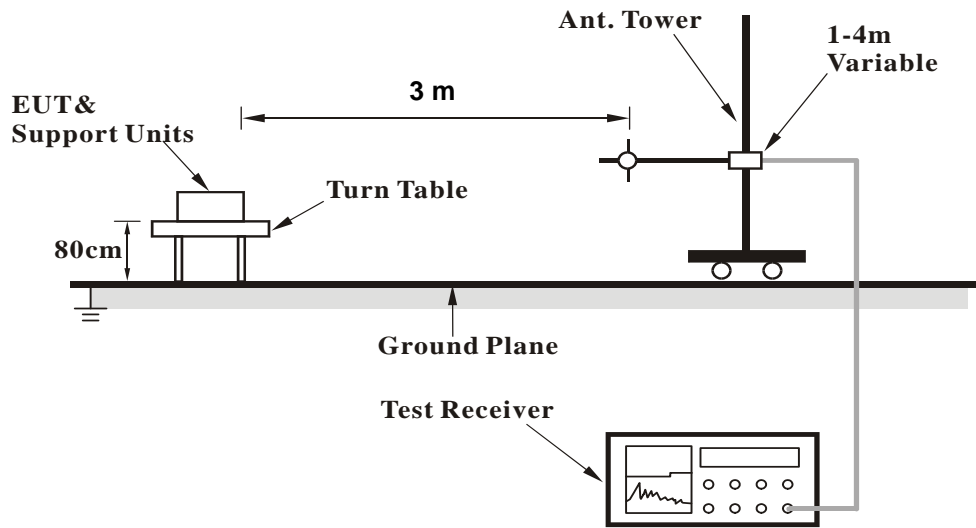

<Radiated Emission above 1 GHz>

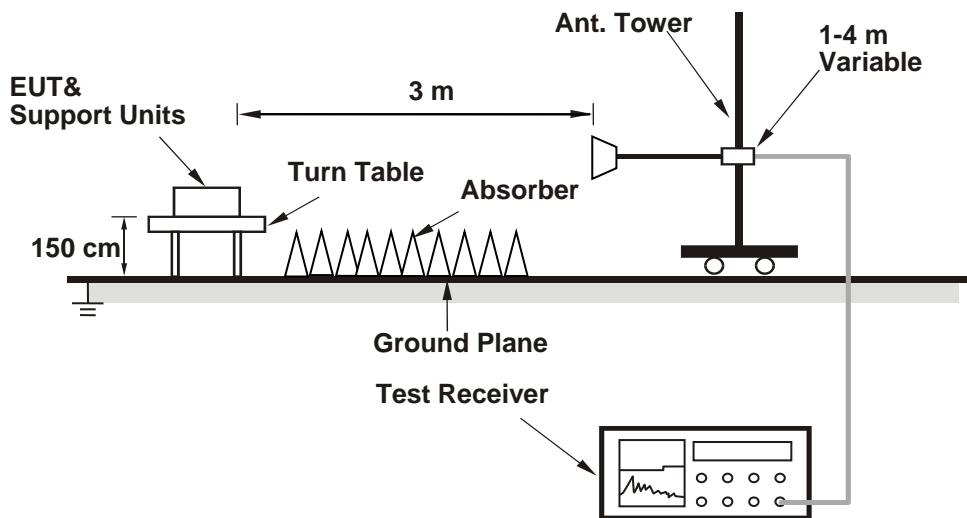

For the actual test configuration, please refer to the attached file (Test Setup Photo).

4.2.5 Test Results

BELOW 1GHz

WCDMA BAND V

Mode	TX channel 4182 (836.4MHz)	Frequency Range	Below 1000 MHz
Environmental Conditions	25deg. C, 70%RH	Input Power	120Vac, 60Hz
Tested By	Noah Chang		

ANTENNA POLARITY & TEST DISTANCE: HORIZONTAL AT 3 M							
NO.	FREQ. (MHz)	READING (dBm)	S.G POWER VALUE (dBm)	CORRECTION FACTOR (dB)	ERP (dBm)	LIMIT (dBm)	MARGIN (dB)
1	39.70	-45.8	-34.7	-10.9	-45.6	-13.0	-32.6
2	125.06	-33.5	-42.8	0.0	-42.8	-13.0	-29.8
3	150.28	-38.6	-45.4	-0.1	-45.5	-13.0	-32.5
4	289.96	-41.4	-52.0	5.2	-46.8	-13.0	-33.8
5	652.74	-49.1	-54.7	4.8	-49.9	-13.0	-36.9
6	937.92	-57.5	-56.5	3.9	-52.6	-13.0	-39.6

Remarks:

1. ERP (dBm) = S.G Value (dBm) + Correction Factor (dB).
2. Correction Factor (dB) = Substitution Antenna Gain (dB) + Cable Loss (dB).

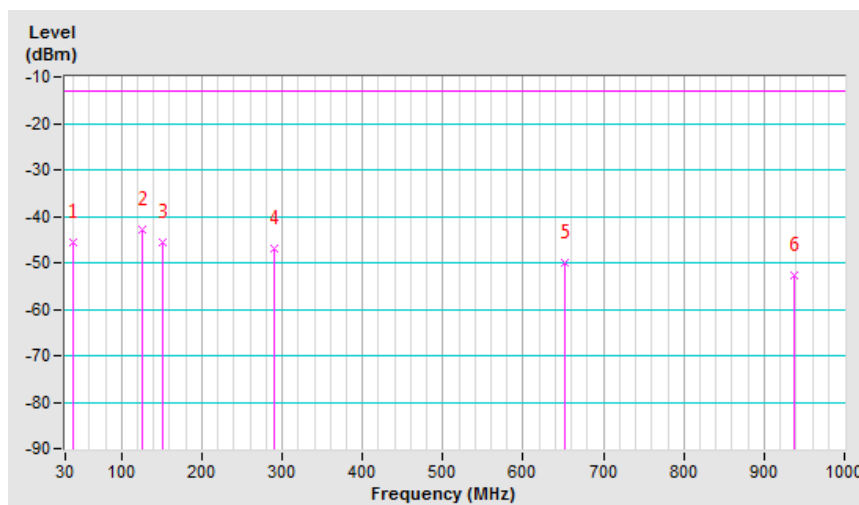

Mode	TX channel 4182 (836.4MHz)	Frequency Range	Below 1000 MHz
Environmental Conditions	25deg. C, 70%RH	Input Power	120Vac, 60Hz
Tested By	Noah Chang		

ANTENNA POLARITY & TEST DISTANCE: VERTICAL AT 3 M							
NO.	FREQ. (MHz)	READING (dBm)	S.G POWER VALUE (dBm)	CORRECTION FACTOR (dB)	ERP (dBm)	LIMIT (dBm)	MARGIN (dB)
1	41.64	-41.9	-40.2	-10.6	-50.8	-13.0	-37.8
2	64.92	-39.2	-42.1	-6.3	-48.4	-13.0	-35.4
3	90.14	-37.8	-45.9	1.1	-44.8	-13.0	-31.8
4	553.80	-46.0	-51.6	4.7	-46.9	-13.0	-33.9
5	732.28	-58.2	-59.7	4.9	-54.8	-13.0	-41.8
6	935.98	-62.8	-60.1	3.9	-56.2	-13.0	-43.2

Remarks:

1. ERP (dBm) = S.G Value (dBm) + Correction Factor (dB).
2. Correction Factor (dB) = Substitution Antenna Gain (dB) + Cable Loss (dB).

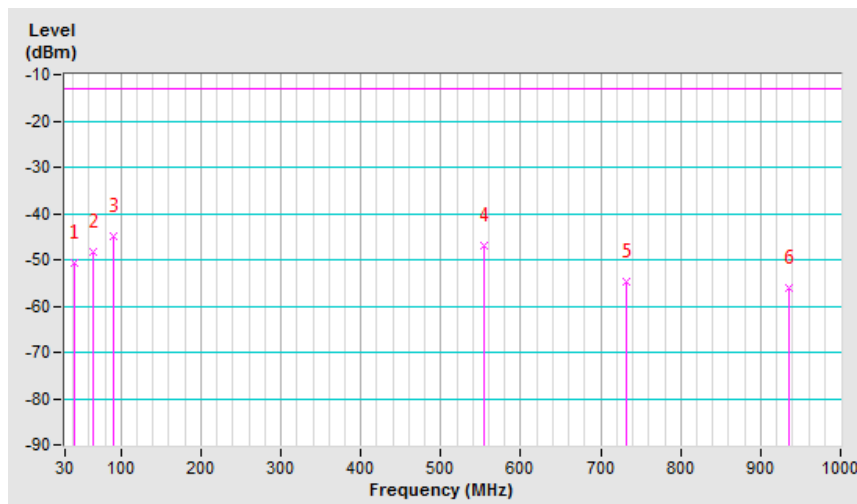

LTE Band 26, Channel Bandwidth 1.4MHz

Mode	TX channel 26797 (824.7MHz)	Frequency Range	Below 1000 MHz
Environmental Conditions	25deg. C, 70%RH	Input Power	120Vac, 60Hz
Tested By	Noah Chang		

ANTENNA POLARITY & TEST DISTANCE: HORIZONTAL AT 3 M

NO.	FREQ. (MHz)	READING (dBm)	S.G POWER VALUE (dBm)	CORRECTION FACTOR (dB)	ERP (dBm)	LIMIT (dBm)	MARGIN (dB)
1	31.94	-59.2	-45.8	-11.9	-57.7	-13.0	-44.7
2	94.02	-43.0	-54.0	1.0	-53.0	-13.0	-40.0
3	136.70	-43.3	-51.5	-0.3	-51.8	-13.0	-38.8
4	173.56	-49.0	-60.7	2.1	-58.6	-13.0	-45.6
5	289.96	-49.6	-60.2	5.2	-55.0	-13.0	-42.0
6	935.98	-60.1	-59.1	3.9	-55.2	-13.0	-42.2

Remarks:

- ERP (dBm) = S.G Value (dBm) + Correction Factor (dB).
- Correction Factor (dB) = Substitution Antenna Gain (dB) + Cable Loss (dB).

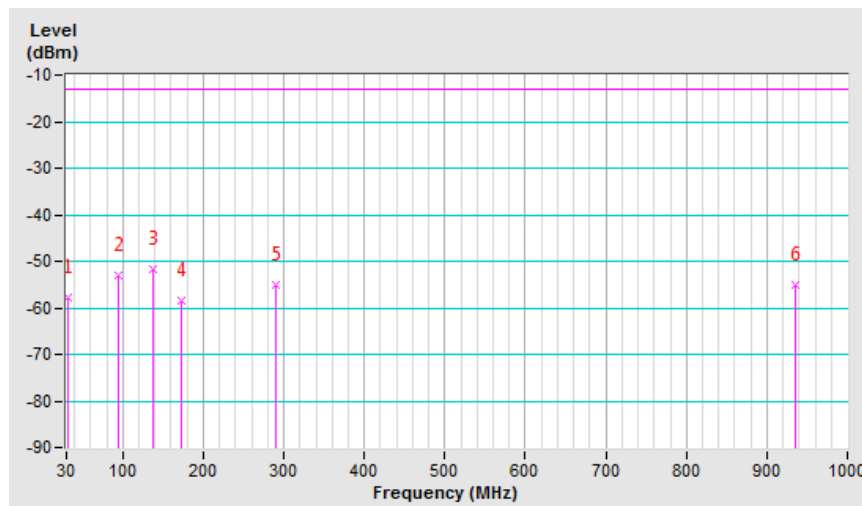

Mode	TX channel 26797 (824.7MHz)	Frequency Range	Below 1000 MHz
Environmental Conditions	25deg. C, 70%RH	Input Power	120Vac, 60Hz
Tested By	Noah Chang		

ANTENNA POLARITY & TEST DISTANCE: VERTICAL AT 3 M							
NO.	FREQ. (MHz)	READING (dBm)	S.G POWER VALUE (dBm)	CORRECTION FACTOR (dB)	ERP (dBm)	LIMIT (dBm)	MARGIN (dB)
1	33.88	-35.1	-35.2	-11.7	-46.9	-13.0	-33.9
2	66.86	-40.6	-43.5	-5.8	-49.3	-13.0	-36.3
3	132.82	-39.5	-46.7	-0.1	-46.8	-13.0	-33.8
4	332.64	-56.2	-64.5	5.2	-59.3	-13.0	-46.3
5	734.22	-59.4	-60.7	4.8	-55.9	-13.0	-42.9
6	939.86	-61.8	-59.0	3.9	-55.1	-13.0	-42.1

Remarks:

1. ERP (dBm) = S.G Value (dBm) + Correction Factor (dB).
2. Correction Factor (dB) = Substitution Antenna Gain (dB) + Cable Loss (dB).

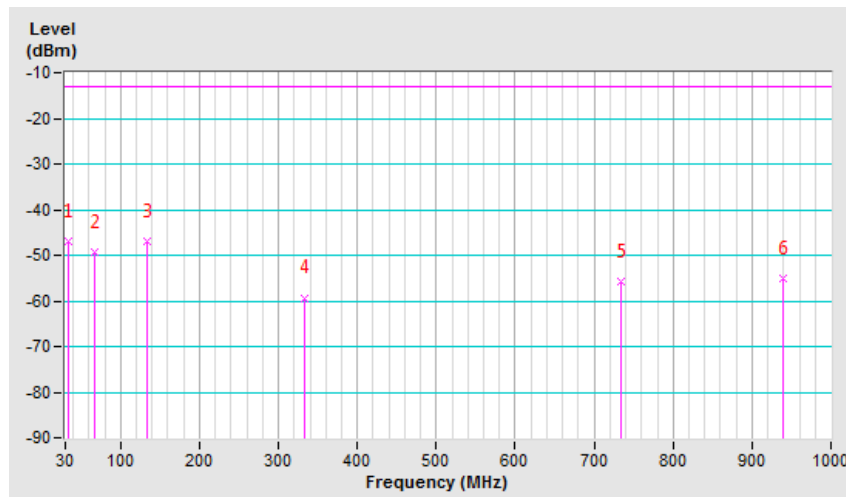

Above 1GHz

WCDMA Band V

Mode	TX channel 4182 (836.4MHz)	Frequency Range	1GHz-18GHz
Environmental Conditions	25deg. C, 70%RH	Input Power	120Vac, 60Hz
Tested By	Noah Chang		

ANTENNA POLARITY & TEST DISTANCE: HORIZONTAL AT 3 M

NO.	FREQ. (MHz)	READING (dBm)	S.G POWER VALUE (dBm)	CORRECTION FACTOR (dB)	ERP (dBm)	LIMIT (dBm)	MARGIN (dB)
1	1672.80 (PK)	-56.2	-59.3	5.5	-53.8	-13.0	-40.8

ANTENNA POLARITY & TEST DISTANCE: VERTICAL AT 3 M

NO.	FREQ. (MHz)	READING (dBm)	S.G POWER VALUE (dBm)	CORRECTION FACTOR (dB)	ERP (dBm)	LIMIT (dBm)	MARGIN (dB)
1	1672.80 (PK)	-57.9	-58.6	5.5	-53.1	-13.0	-40.1

Remarks:

1. ERP (dBm) = S.G Value (dBm) + Correction Factor (dB).
2. Correction Factor (dB) = Substitution Antenna Gain (dB) + Cable Loss (dB).

LTE Band 26, Channel Bandwidth 1.4MHz

Mode	TX channel 26797 (824.7MHz)	Frequency Range	1GHz-18GHz
Environmental Conditions	25deg. C, 70%RH	Input Power	120Vac, 60Hz
Tested By	Noah Chang		

ANTENNA POLARITY & TEST DISTANCE: HORIZONTAL AT 3 M

NO.	FREQ. (MHz)	READING (dBm)	S.G POWER VALUE (dBm)	CORRECTION FACTOR (dB)	ERP (dBm)	LIMIT (dBm)	MARGIN (dB)
1	1649.40 (PK)	-55.2	-58.5	5.5	-53.0	-13.0	-40.0

ANTENNA POLARITY & TEST DISTANCE: VERTICAL AT 3 M

NO.	FREQ. (MHz)	READING (dBm)	S.G POWER VALUE (dBm)	CORRECTION FACTOR (dB)	ERP (dBm)	LIMIT (dBm)	MARGIN (dB)
1	1649.40 (PK)	-59.5	-60.6	5.5	-55.1	-13.0	-42.1

Remarks:

1. ERP (dBm) = S.G Value (dBm) + Correction Factor (dB).
2. Correction Factor (dB) = Substitution Antenna Gain (dB) + Cable Loss (dB).

5 Pictures of Test Arrangements

Please refer to the attached file (Test Setup Photo).

Appendix – Information of the Testing Laboratories

We, Bureau Veritas Consumer Products Services (H.K.) Ltd., Taoyuan Branch, were founded in 1988 to provide our best service in EMC, Radio, Telecom and Safety consultation. Our laboratories are FCC recognized accredited test firms and accredited according to ISO/IEC 17025.

If you have any comments, please feel free to contact us at the following:

Lin Kou EMC/RF Lab

Tel: 886-2-26052180

Fax: 886-2-26051924

Hsin Chu EMC/RF/Telecom Lab

Tel: 886-3-6668565

Fax: 886-3-6668323

Hwa Ya EMC/RF/Safety Lab

Tel: 886-3-3183232

Fax: 886-3-3270892

Email: service.adt@tw.bureauveritas.com

Web Site: www.bureauveritas-adt.com

The address and road map of all our labs can be found in our web site also.

--- END ---