

SAR Plots

- Verification Plots
- SAR Test Plots

DT&C Co., Ltd.

DUT: Dipole 835 MHz; Type: D835V2; Serial: D835V2 - SN:4d159

Communication System: CW (0); Frequency: 835 MHz; Duty Cycle: 1:1
Medium parameters used: $f = 835$ MHz; $\sigma = 0.907$ S/m; $\epsilon_r = 42.238$; $\rho = 1000$ kg/m³
Phantom section: Flat Section

DASY5 Configuration:

Probe: EX3DV4 - SN3866; ConvF(9.36, 9.36, 9.36); Calibrated: 6/29/2016; ; Electronics: DAE4 Sn1391
Phantom: SAM with CRP_2016_07_22_middle; Type: QD000P40CD; Serial: TP:1786
Measurement SW: DASY52, Version 52.8 (8); SEMCAD X Version 14.6.10 (7331)

Test Date: 2017-03-13; Ambient Temp: 21.0; Tissue Temp: 21.9

835 MHz System Verification

Area Scan (6x13x1): Measurement grid: dx=15mm, dy=15mm

Zoom Scan (7x7x7)/Cube 0: Measurement grid: dx=5mm, dy=5mm, dz=5mm

Power Drift = -0.15 dB

Peak SAR (extrapolated) = 3.38 W/kg

SAR(1 g) = 2.29 W/kg; SAR(10 g) = 1.51 W/kg

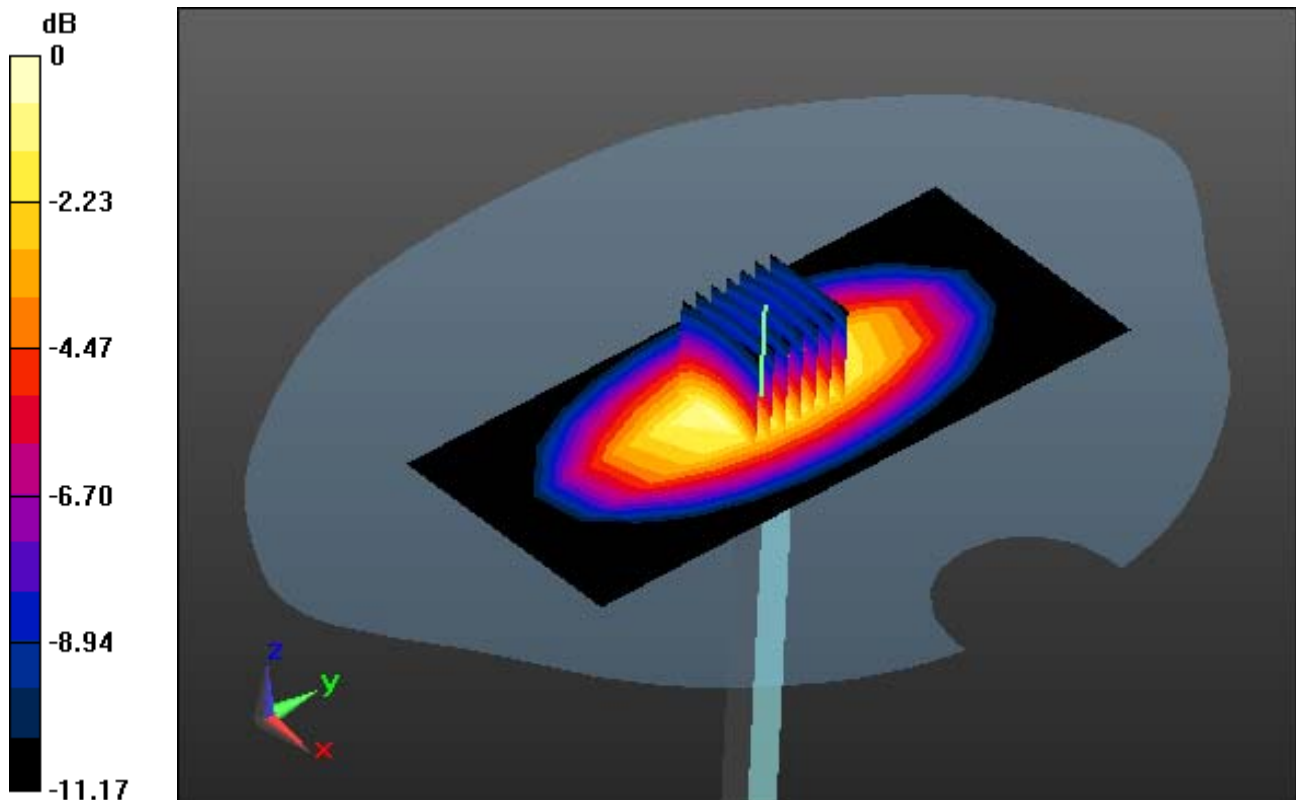

0 dB = 3.01 W/kg

DT&C Co., Ltd.

DUT: Dipole 835 MHz; Type: D835V2; Serial: D835V2 - SN:4d159

Communication System: CW (0); Frequency: 835 MHz; Duty Cycle: 1:1
Medium parameters used: $f = 835$ MHz; $\sigma = 0.907$ S/m; $\epsilon_r = 42.238$; $\rho = 1000$ kg/m³
Phantom section: Flat Section

DASY5 Configuration:

Probe: EX3DV4 - SN3866; ConvF(9.36, 9.36, 9.36); Calibrated: 6/29/2016; ; Electronics: DAE4 Sn1391
Phantom: SAM with CRP_2016_07_22_middle; Type: QD000P40CD; Serial: TP:1786
Measurement SW: DASY52, Version 52.8 (8); SEMCAD X Version 14.6.10 (7331)

Test Date: 2017-03-13; Ambient Temp: 21.0; Tissue Temp: 21.9

835 MHz System Verification

Area Scan (6x13x1): Measurement grid: dx=15mm, dy=15mm

Zoom Scan (7x7x7)/Cube 0: Measurement grid: dx=5mm, dy=5mm, dz=5mm

Power Drift = -0.15 dB

Peak SAR (extrapolated) = 3.38 W/kg

SAR(1 g) = 2.29 W/kg; SAR(10 g) = 1.51 W/kg

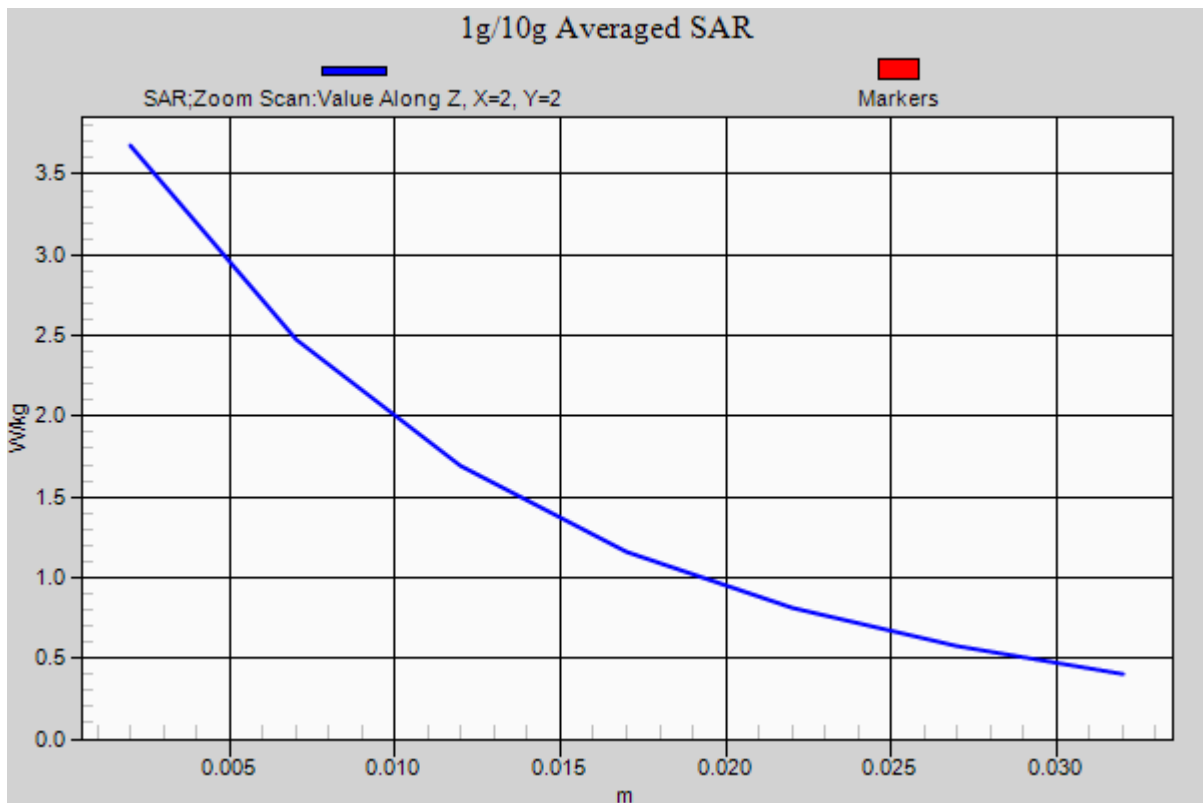

DT&C Co., Ltd.

DUT: Dipole 835 MHz; Type: D835V2; Serial: D835V2 - SN:4d159

Communication System: CW (0); Frequency: 835 MHz; Duty Cycle: 1:1
Medium parameters used: $f = 835$ MHz; $\sigma = 1.005$ S/m; $\epsilon_r = 54.282$; $\rho = 1000$ kg/m³
Phantom section: Flat Section

DASY5 Configuration:

Probe: EX3DV4 - SN3866; ConvF(9.21, 9.21, 9.21); Calibrated: 6/29/2016; ; Electronics: DAE4 Sn1391
Phantom: SAM with CRP_2016_07_22_middle; Type: QD000P40CD; Serial: TP:1786
Measurement SW: DASY52, Version 52.8 (8); SEMCAD X Version 14.6.10 (7331)

Test Date: 2017-03-15; Ambient Temp: 20.8; Tissue Temp: 22.0

835 MHz System Verification

Area Scan (6x13x1): Measurement grid: dx=15mm, dy=15mm

Zoom Scan (7x7x7)/Cube 0: Measurement grid: dx=5mm, dy=5mm, dz=5mm

Power Drift = 0.10 dB

Peak SAR (extrapolated) = 5.15 W/kg

SAR(1 g) = 2.46 W/kg; SAR(10 g) = 1.6 W/kg

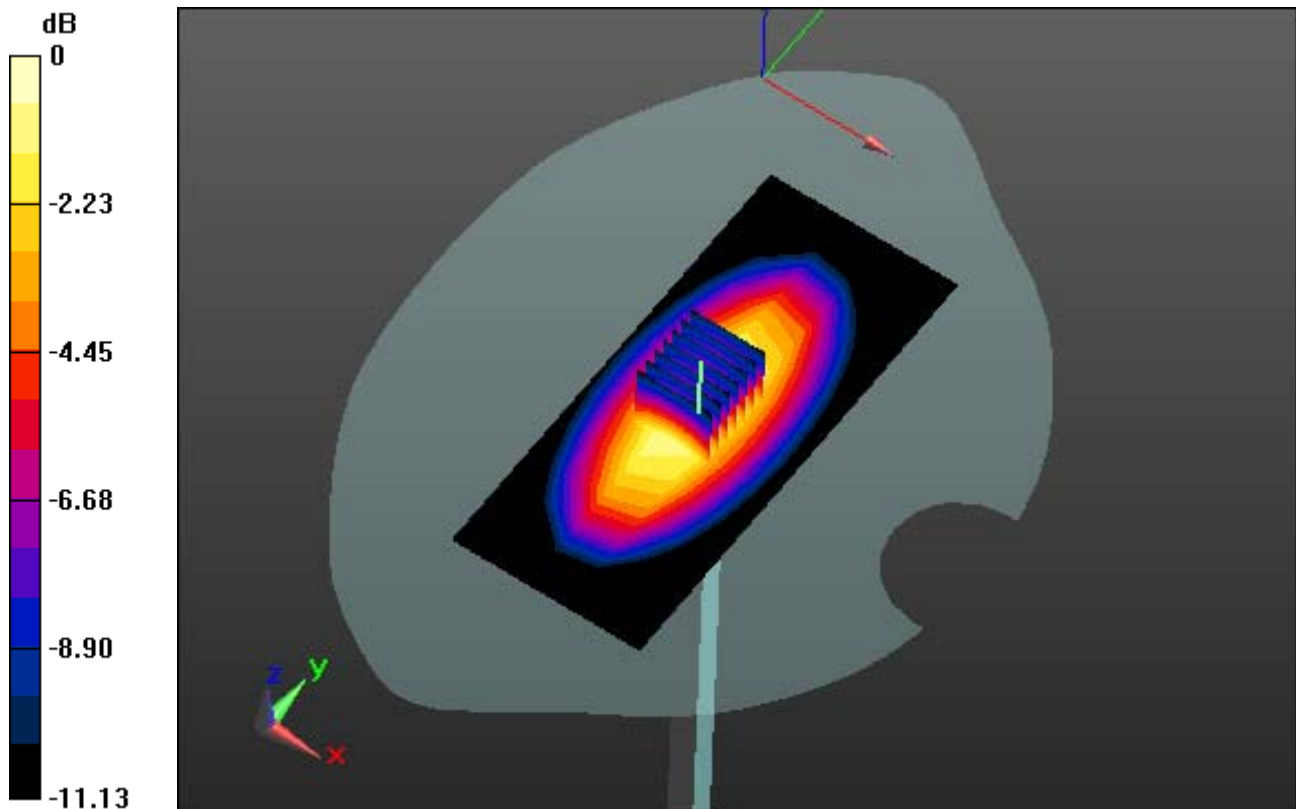

0 dB = 4.34 W/kg

DT&C Co., Ltd.

DUT: Dipole 835 MHz; Type: D835V2; Serial: D835V2 - SN:4d159

Communication System: CW (0); Frequency: 835 MHz; Duty Cycle: 1:1
Medium parameters used: $f = 835$ MHz; $\sigma = 1.005$ S/m; $\epsilon_r = 54.282$; $\rho = 1000$ kg/m³
Phantom section: Flat Section

DASY5 Configuration:

Probe: EX3DV4 - SN3866; ConvF(9.21, 9.21, 9.21); Calibrated: 6/29/2016; ; Electronics: DAE4 Sn1391
Phantom: SAM with CRP_2016_07_22_middle; Type: QD000P40CD; Serial: TP:1786
Measurement SW: DASY52, Version 52.8 (8); SEMCAD X Version 14.6.10 (7331)

Test Date: 2017-03-15; Ambient Temp: 20.8; Tissue Temp: 22.0

835 MHz System Verification

Area Scan (6x13x1): Measurement grid: dx=15mm, dy=15mm

Zoom Scan (7x7x7)/Cube 0: Measurement grid: dx=5mm, dy=5mm, dz=5mm

Power Drift = 0.10 dB

Peak SAR (extrapolated) = 5.15 W/kg

SAR(1 g) = 2.46 W/kg; SAR(10 g) = 1.6 W/kg

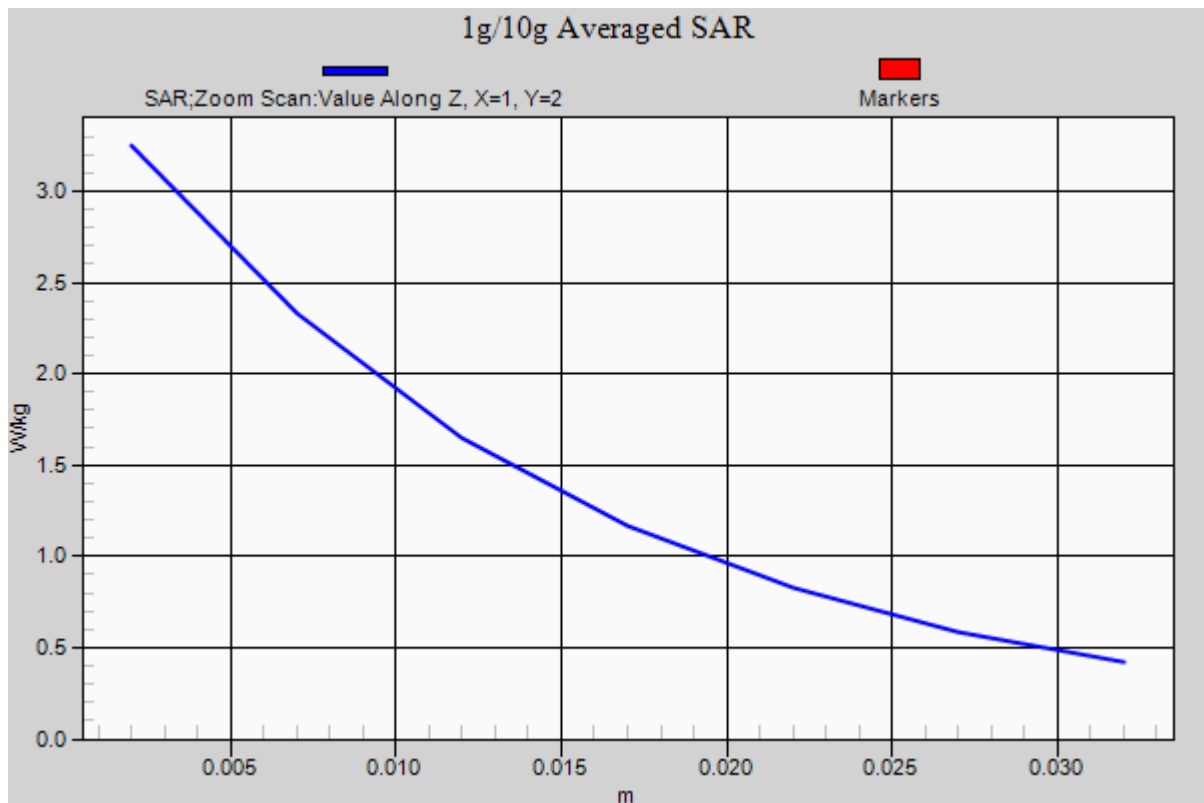

DT&C Co., Ltd.

DUT: Dipole 835 MHz; Type: D835V2; Serial: D835V2 - SN:4d159

Communication System: CW (0); Frequency: 835 MHz; Duty Cycle: 1:1
Medium parameters used: $f = 835$ MHz; $\sigma = 0.99$ S/m; $\epsilon_r = 53.456$; $\rho = 1000$ kg/m³
Phantom section: Flat Section

DASY5 Configuration:

Probe: EX3DV4 - SN3866; ConvF(9.21, 9.21, 9.21); Calibrated: 6/29/2016; ; Electronics: DAE4 Sn1391
Phantom: SAM with CRP_2016_07_22_middle; Type: QD000P40CD; Serial: TP:1786
Measurement SW: DASY52, Version 52.8 (8); SEMCAD X Version 14.6.10 (7331)

Test Date: 2017-03-14; Ambient Temp: 20.9; Tissue Temp: 21.2

835 MHz System Verification

Area Scan (6x13x1): Measurement grid: dx=15mm, dy=15mm

Zoom Scan (7x7x7)/Cube 0: Measurement grid: dx=5mm, dy=5mm, dz=5mm

Power Drift = 0.10 dB

Peak SAR (extrapolated) = 3.52 W/kg

SAR(1 g) = 2.48 W/kg; SAR(10 g) = 1.63 W/kg

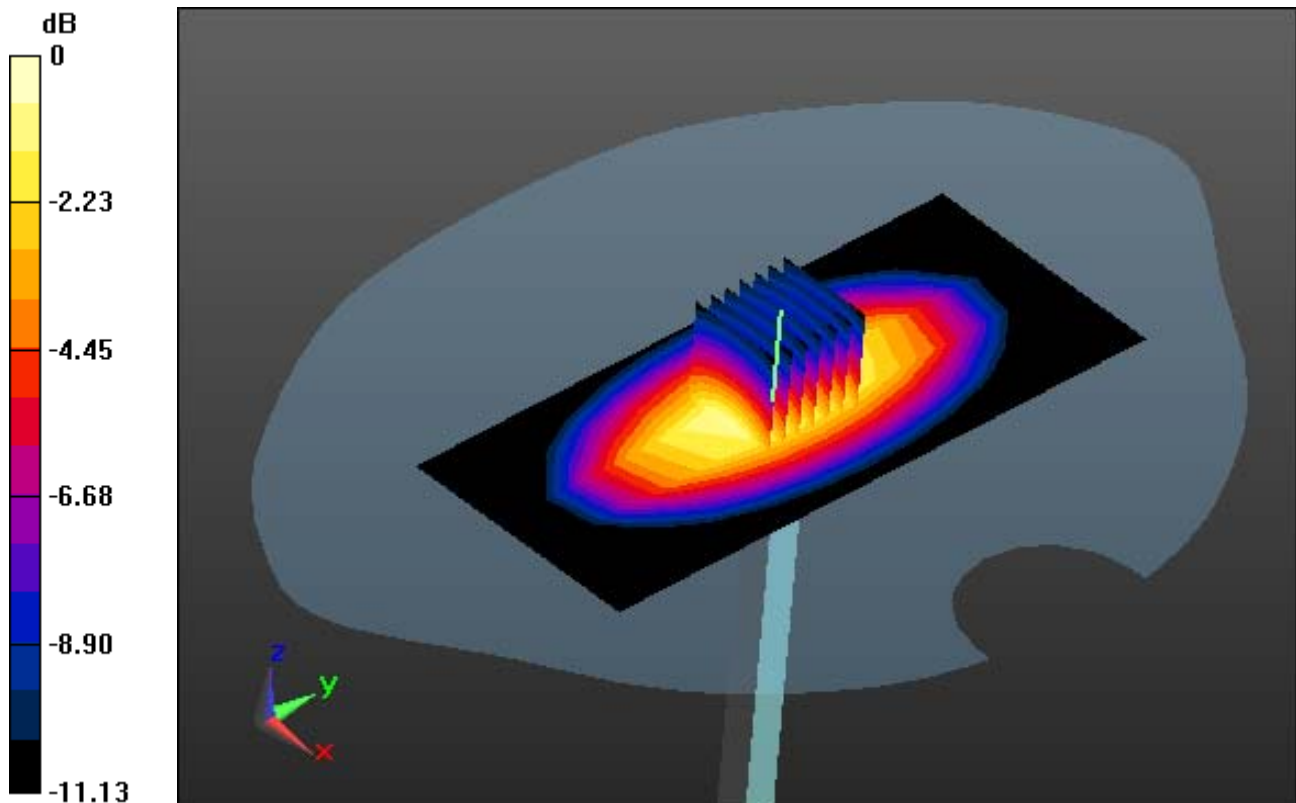

0 dB = 2.84 W/kg

DT&C Co., Ltd.

DUT: Dipole 835 MHz; Type: D835V2; Serial: D835V2 - SN:4d159

Communication System: CW (0); Frequency: 835 MHz; Duty Cycle: 1:1
Medium parameters used: $f = 835$ MHz; $\sigma = 0.99$ S/m; $\epsilon_r = 53.456$; $\rho = 1000$ kg/m³
Phantom section: Flat Section

DASY5 Configuration:

Probe: EX3DV4 - SN3866; ConvF(9.21, 9.21, 9.21); Calibrated: 6/29/2016; ; Electronics: DAE4 Sn1391
Phantom: SAM with CRP_2016_07_22_middle; Type: QD000P40CD; Serial: TP:1786
Measurement SW: DASY52, Version 52.8 (8); SEMCAD X Version 14.6.10 (7331)

Test Date: 2017-03-14; Ambient Temp: 20.9; Tissue Temp: 21.2

835 MHz System Verification

Area Scan (6x13x1): Measurement grid: dx=15mm, dy=15mm

Zoom Scan (7x7x7)/Cube 0: Measurement grid: dx=5mm, dy=5mm, dz=5mm

Power Drift = 0.10 dB

Peak SAR (extrapolated) = 3.52 W/kg

SAR(1 g) = 2.48 W/kg; SAR(10 g) = 1.63 W/kg

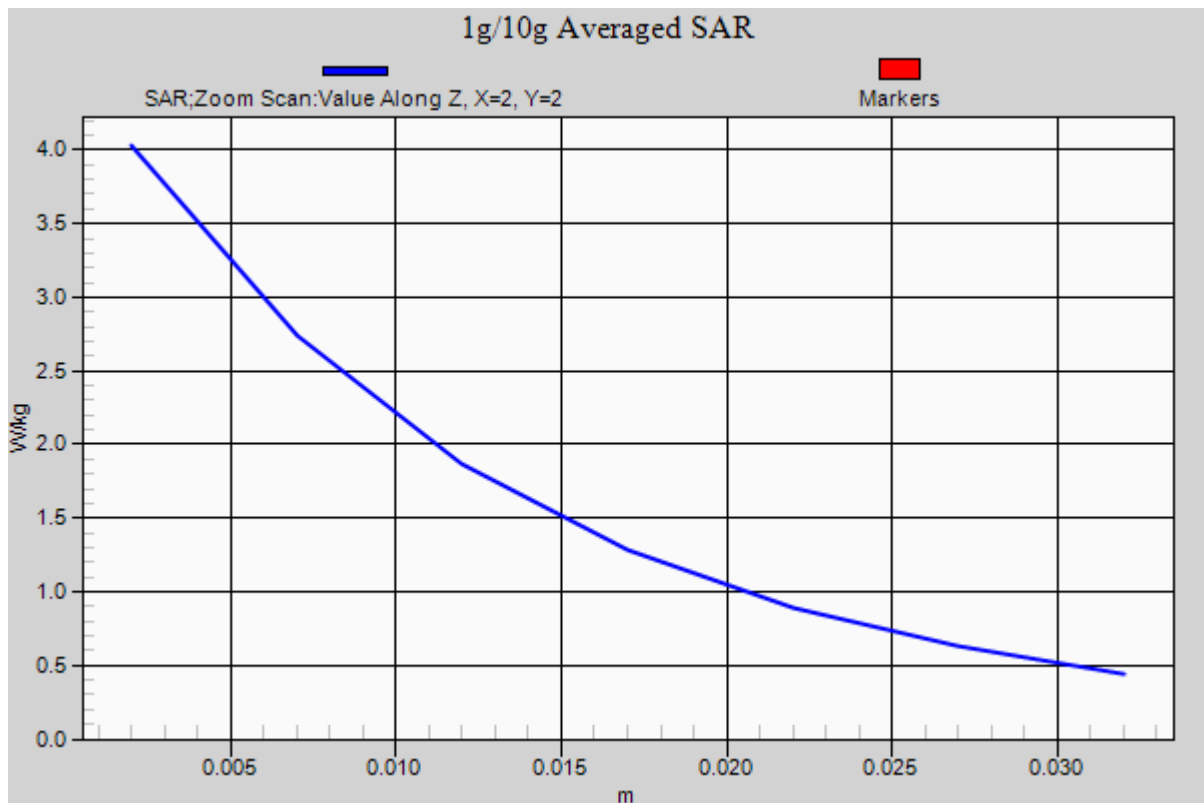

DT&C Co., Ltd.

DUT: Dipole 835 MHz; Type: D835V2; Serial: D835V2 - SN:4d159

Communication System: CW (0); Frequency: 835 MHz; Duty Cycle: 1:1
Medium parameters used: $f = 835$ MHz; $\sigma = 0.999$ S/m; $\epsilon_r = 54.228$; $\rho = 1000$ kg/m³
Phantom section: Flat Section

DASY5 Configuration:

Probe: EX3DV4 - SN3866; ConvF(9.21, 9.21, 9.21); Calibrated: 6/29/2016; ; Electronics: DAE4 Sn1391
Phantom: SAM with CRP_2016_07_22_middle; Type: QD000P40CD; Serial: TP:1786
Measurement SW: DASY52, Version 52.8 (8); SEMCAD X Version 14.6.10 (7331)

Test Date: 2017-03-07; Ambient Temp: 20.8; Tissue Temp: 21.3

835 MHz System Verification

Area Scan (7x9x1): Measurement grid: dx=15mm, dy=15mm

Zoom Scan (7x7x7)/Cube 0: Measurement grid: dx=5mm, dy=5mm, dz=5mm

Power Drift = -0.05 dB

Peak SAR (extrapolated) = 4.04 W/kg

SAR(1 g) = 2.38 W/kg; SAR(10 g) = 1.55 W/kg

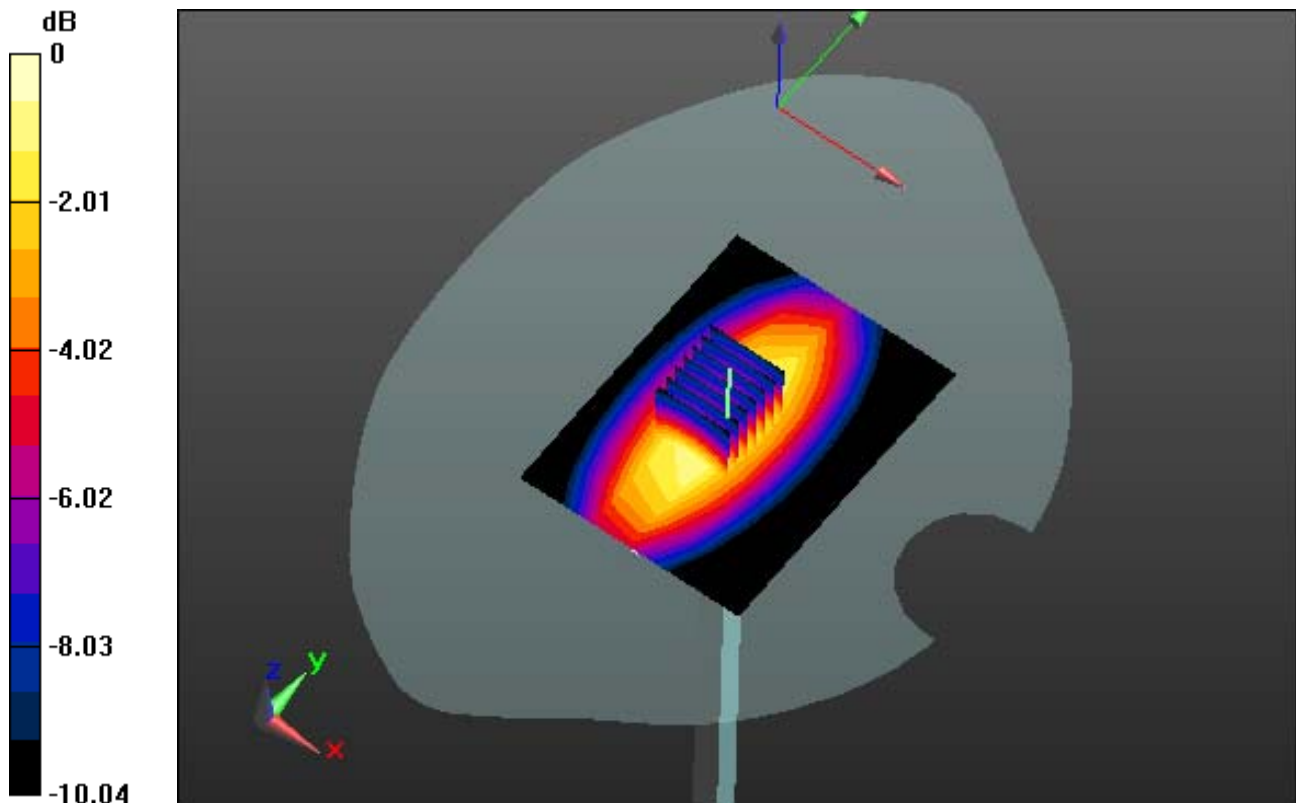

0 dB = 3.31 W/kg

DT&C Co., Ltd.

DUT: Dipole 835 MHz; Type: D835V2; Serial: D835V2 - SN:4d159

Communication System: CW (0); Frequency: 835 MHz; Duty Cycle: 1:1
Medium parameters used: $f = 835$ MHz; $\sigma = 0.999$ S/m; $\epsilon_r = 54.228$; $\rho = 1000$ kg/m³
Phantom section: Flat Section

DASY5 Configuration:

Probe: EX3DV4 - SN3866; ConvF(9.21, 9.21, 9.21); Calibrated: 6/29/2016; ; Electronics: DAE4 Sn1391
Phantom: SAM with CRP_2016_07_22_middle; Type: QD000P40CD; Serial: TP:1786
Measurement SW: DASY52, Version 52.8 (8); SEMCAD X Version 14.6.10 (7331)

Test Date: 2017-03-07; Ambient Temp: 20.8; Tissue Temp: 21.3

835 MHz System Verification

Area Scan (7x9x1): Measurement grid: dx=15mm, dy=15mm

Zoom Scan (7x7x7)/Cube 0: Measurement grid: dx=5mm, dy=5mm, dz=5mm

Power Drift = -0.05 dB

Peak SAR (extrapolated) = 4.04 W/kg

SAR(1 g) = 2.38 W/kg; SAR(10 g) = 1.55 W/kg

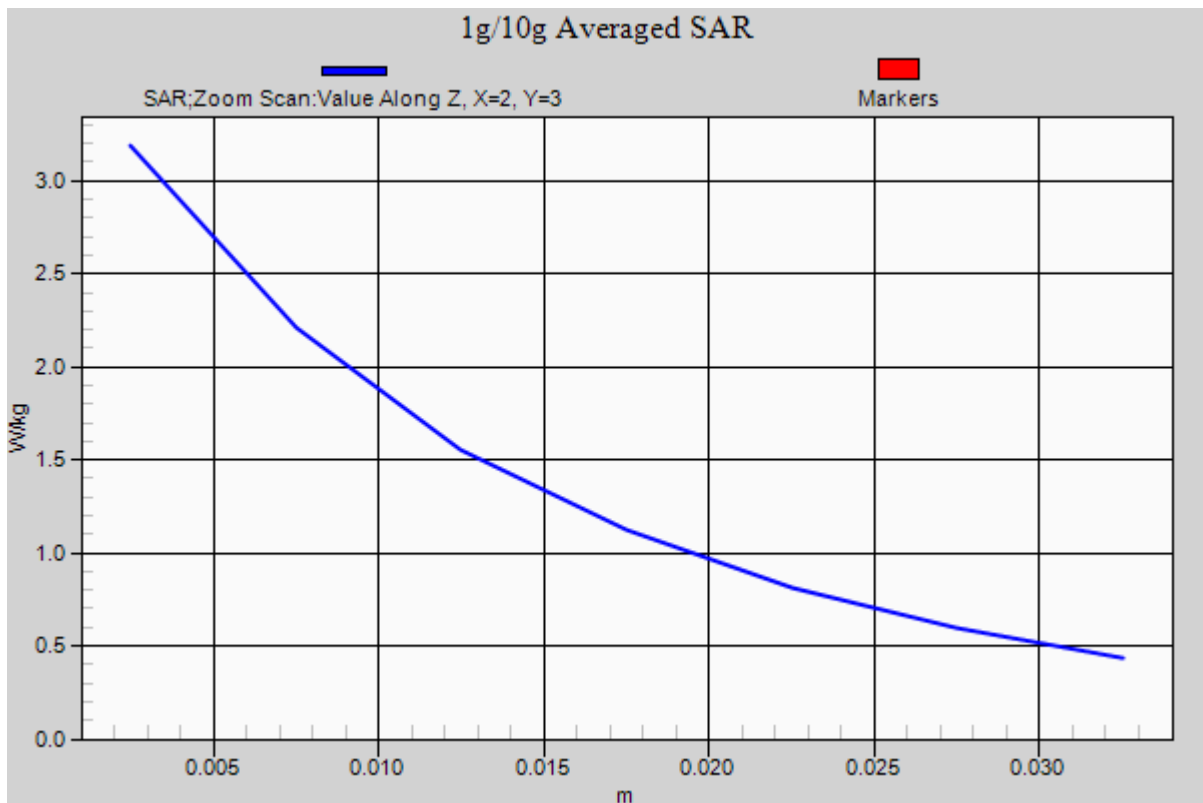

DT&C Co., Ltd.

DUT: Dipole 1900 MHz; Type: D1900V2; Serial: D1900V2 - SN:5d176

Communication System: CW; Frequency: 1900 MHz; Duty Cycle: 1:1
Medium parameters used: $f = 1900$ MHz; $\sigma = 1.431$ S/m; $\epsilon_r = 39.181$; $\rho = 1000$ kg/m³
Phantom section: Flat Section

DASY5 Configuration:

Probe: EX3DV4 - SN3866; ConvF(7.56, 7.56, 7.56); Calibrated: 6/29/2016; ; Electronics: DAE4 Sn1391
Phantom: SAM with CRP_2016_07_22_middle; Type: QD000P40CD; Serial: TP:1786
Measurement SW: DASY52, Version 52.8 (8); SEMCAD X Version 14.6.10 (7331)

Test Date: 2017-02-24; Ambient Temp: 21.3; Tissue Temp: 22.6

1900 MHz System Verification

Area Scan (7x10x1): Measurement grid: dx=10mm, dy=10mm

Zoom Scan (7x7x7)/Cube 0: Measurement grid: dx=5mm, dy=5mm, dz=5mm

Power Drift = 0.03 dB

Peak SAR (extrapolated) = 20.4 W/kg

SAR(1 g) = 10.9 W/kg; SAR(10 g) = 5.65 W/kg

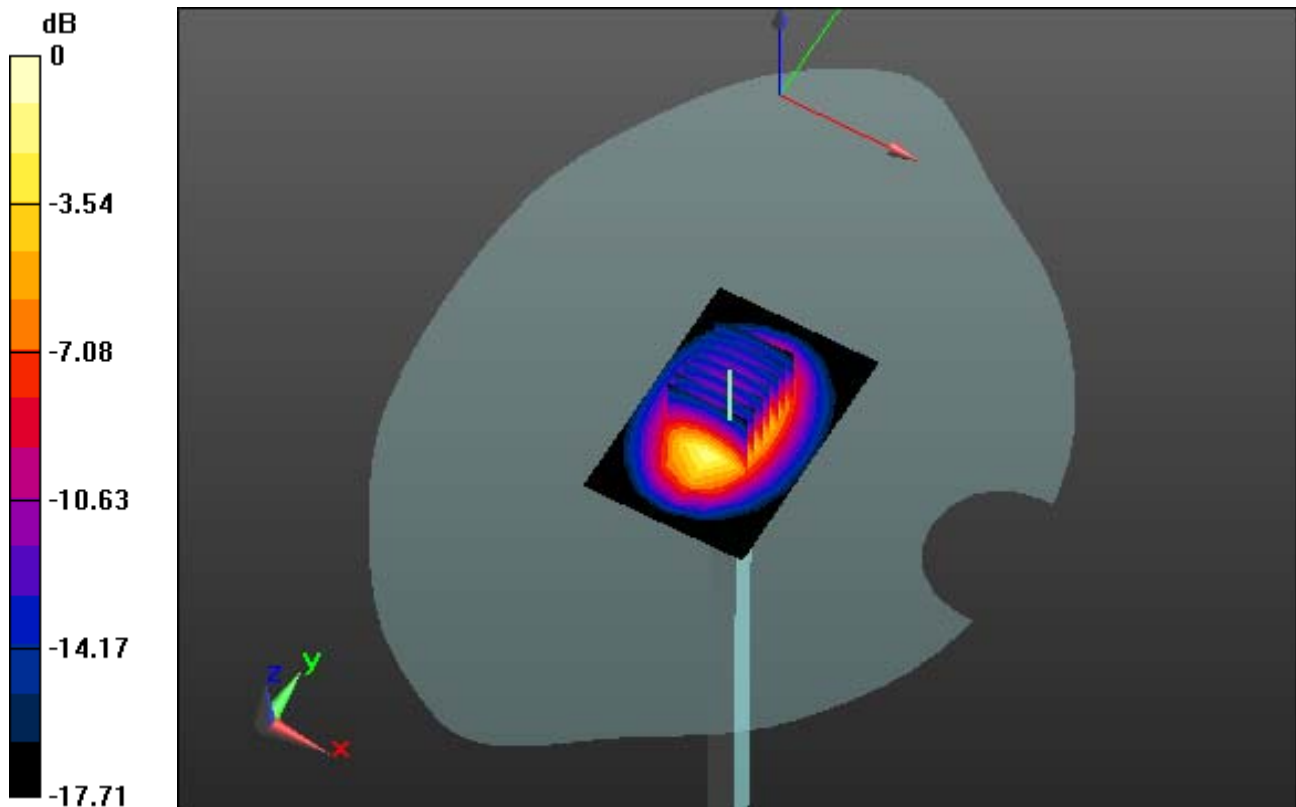

0 dB = 14.9 W/kg

DT&C Co., Ltd.

DUT: Dipole 1900 MHz; Type: D1900V2; Serial: D1900V2 - SN:5d176

Communication System: CW; Frequency: 1900 MHz; Duty Cycle: 1:1
Medium parameters used: $f = 1900$ MHz; $\sigma = 1.431$ S/m; $\epsilon_r = 39.181$; $\rho = 1000$ kg/m³
Phantom section: Flat Section

DASY5 Configuration:

Probe: EX3DV4 - SN3866; ConvF(7.56, 7.56, 7.56); Calibrated: 6/29/2016; ; Electronics: DAE4 Sn1391
Phantom: SAM with CRP_2016_07_22_middle; Type: QD000P40CD; Serial: TP:1786
Measurement SW: DASY52, Version 52.8 (8); SEMCAD X Version 14.6.10 (7331)

Test Date: 2017-02-24; Ambient Temp: 21.3; Tissue Temp: 22.6

1900 MHz System Verification

Area Scan (7x10x1): Measurement grid: dx=10mm, dy=10mm

Zoom Scan (7x7x7)/Cube 0: Measurement grid: dx=5mm, dy=5mm, dz=5mm

Power Drift = 0.03 dB

Peak SAR (extrapolated) = 20.4 W/kg

SAR(1 g) = 10.9 W/kg; SAR(10 g) = 5.65 W/kg

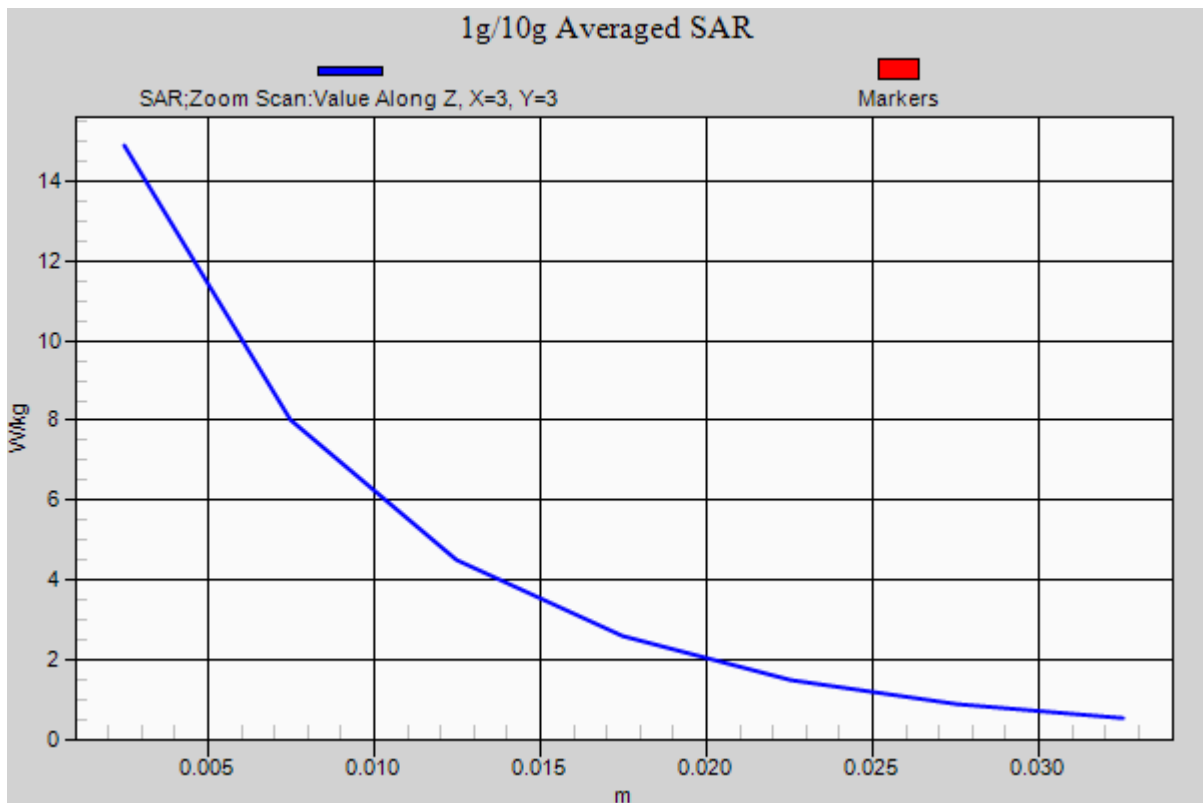

DT&C Co., Ltd.

DUT: Dipole 2450 MHz; Type: D2450V2; Serial: D2450V2 - SN:920

Communication System: CW (0); Frequency: 2450 MHz; Duty Cycle: 1:1
Medium parameters used: $f = 2450$ MHz; $\sigma = 1.854$ S/m; $\epsilon_r = 38.342$; $\rho = 1000$ kg/m³
Phantom section: Flat Section

DASY5 Configuration:

Probe: EX3DV4 - SN3866; ConvF(7.17, 7.17, 7.17); Calibrated: 6/29/2016; ; Electronics: DAE4 Sn1391
Phantom: SAM with CRP_2016_07_22_middle; Type: QD000P40CD; Serial: TP:1786
Measurement SW: DASY52, Version 52.8 (8); SEMCAD X Version 14.6.10 (7331)

Test Date: 2017-02-27; Ambient Temp: 20.2; Tissue Temp: 21.0

2450 MHz System Verification

Area Scan (7x9x1): Measurement grid: dx=12mm, dy=12mm

Zoom Scan (7x7x7)/Cube 0: Measurement grid: dx=5mm, dy=5mm, dz=5mm

Power Drift = -0.01 dB

Peak SAR (extrapolated) = 29.0 W/kg

SAR(1 g) = 13.4 W/kg; SAR(10 g) = 6.07 W/kg

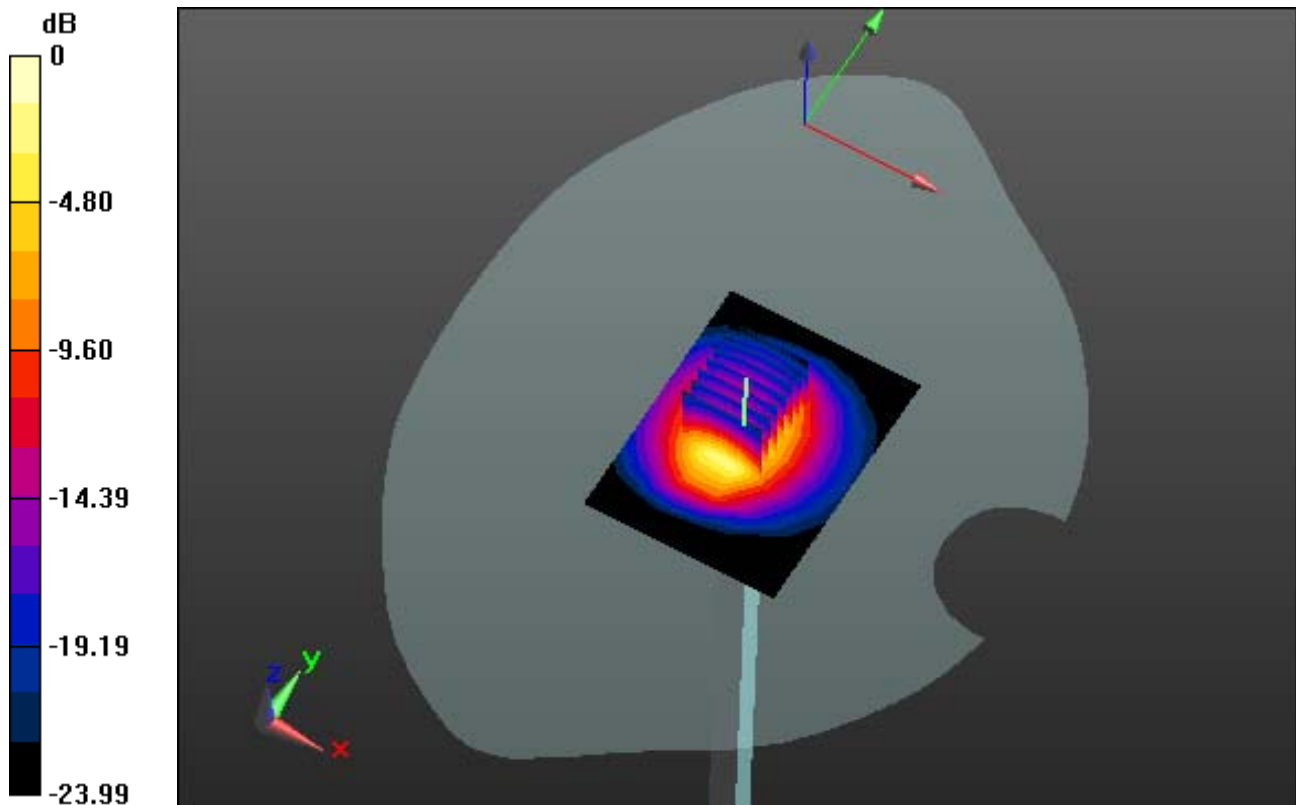

0 dB = 19.1 W/kg

DT&C Co., Ltd.

DUT: Dipole 2450 MHz; Type: D2450V2; Serial: D2450V2 - SN:920

Communication System: CW (0); Frequency: 2450 MHz; Duty Cycle: 1:1
Medium parameters used: $f = 2450$ MHz; $\sigma = 1.854$ S/m; $\epsilon_r = 38.342$; $\rho = 1000$ kg/m³
Phantom section: Flat Section

DASY5 Configuration:

Probe: EX3DV4 - SN3866; ConvF(7.17, 7.17, 7.17); Calibrated: 6/29/2016; ; Electronics: DAE4 Sn1391
Phantom: SAM with CRP_2016_07_22_middle; Type: QD000P40CD; Serial: TP:1786
Measurement SW: DASY52, Version 52.8 (8); SEMCAD X Version 14.6.10 (7331)

Test Date: 2017-02-27; Ambient Temp: 20.2; Tissue Temp: 21.0

2450 MHz System Verification

Area Scan (7x9x1): Measurement grid: dx=12mm, dy=12mm

Zoom Scan (7x7x7)/Cube 0: Measurement grid: dx=5mm, dy=5mm, dz=5mm

Power Drift = -0.01 dB

Peak SAR (extrapolated) = 29.0 W/kg

SAR(1 g) = 13.4 W/kg; SAR(10 g) = 6.07 W/kg

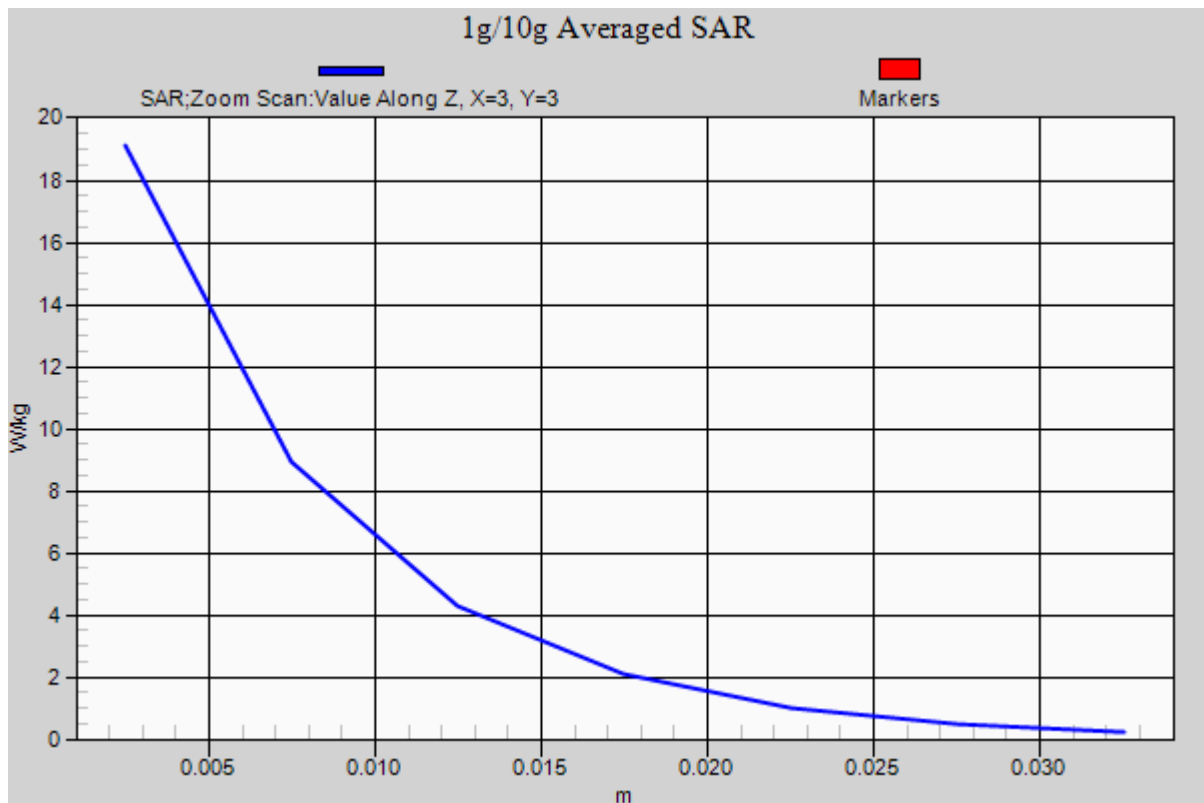

DT&C Co., Ltd.

DUT: Dipole 2450 MHz; Type: D2450V2; Serial: D2450V2 - SN:920

Communication System: CW (0); Frequency: 2450 MHz; Duty Cycle: 1:1
Medium parameters used: $f = 2450$ MHz; $\sigma = 1.965$ S/m; $\epsilon_r = 50.968$; $\rho = 1000$ kg/m³
Phantom section: Flat Section

DASY5 Configuration:

Probe: EX3DV4 - SN3866; ConvF(7.2, 7.2, 7.2); Calibrated: 6/29/2016; ; Electronics: DAE4 Sn1391
Phantom: SAM with CRP_2016_07_22_middle; Type: QD000P40CD; Serial: TP:1786
Measurement SW: DASY52, Version 52.8 (8); SEMCAD X Version 14.6.10 (7331)

Test Date: 2017-02-27; Ambient Temp: 20.2; Tissue Temp: 21.2

2450 MHz System Verification

Area Scan (7x9x1): Measurement grid: dx=12mm, dy=12mm

Zoom Scan (7x7x7)/Cube 0: Measurement grid: dx=5mm, dy=5mm, dz=5mm

Power Drift = -0.09 dB

Peak SAR (extrapolated) = 29.4 W/kg

SAR(1 g) = 12.9 W/kg; SAR(10 g) = 5.98 W/kg

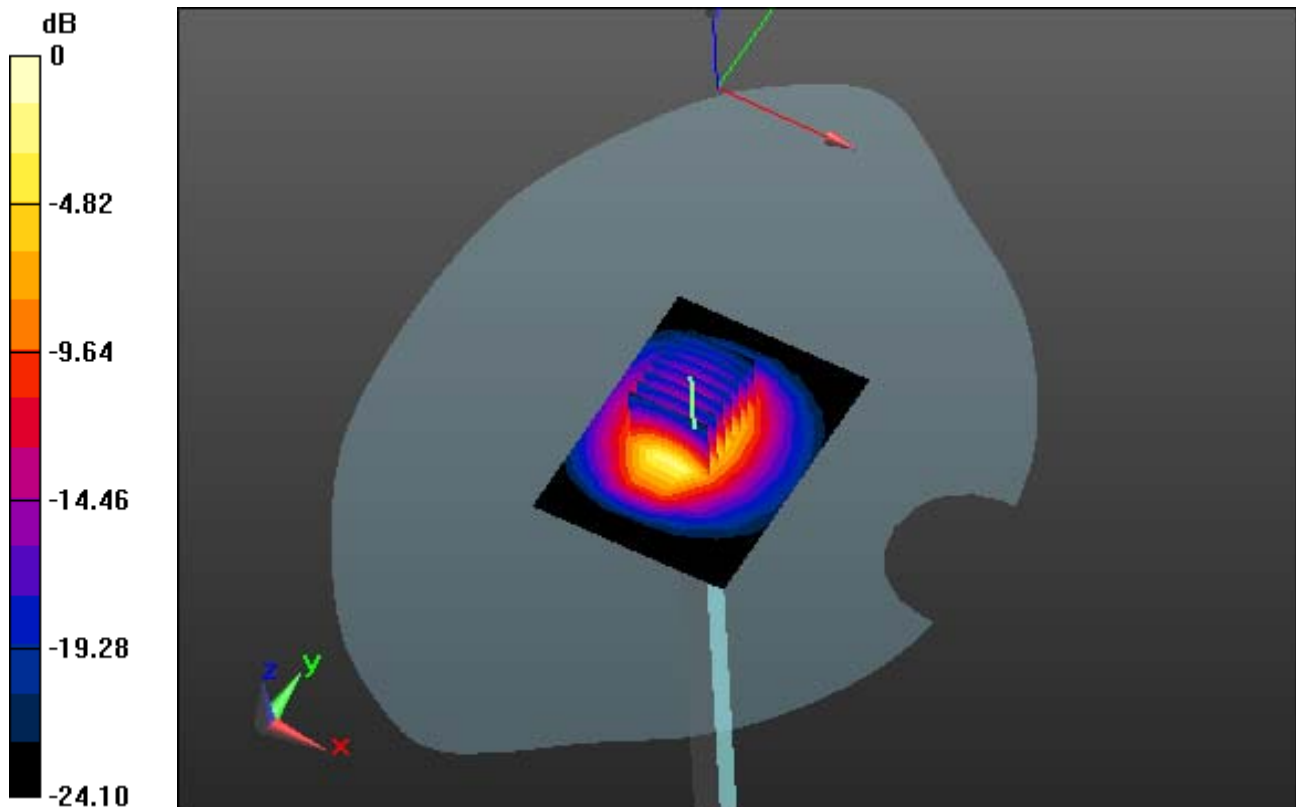

0 dB = 19.5 W/kg

DT&C Co., Ltd.

DUT: Dipole 2450 MHz; Type: D2450V2; Serial: D2450V2 - SN:920

Communication System: CW (0); Frequency: 2450 MHz; Duty Cycle: 1:1
Medium parameters used: $f = 2450$ MHz; $\sigma = 1.965$ S/m; $\epsilon_r = 50.968$; $\rho = 1000$ kg/m³
Phantom section: Flat Section

DASY5 Configuration:

Probe: EX3DV4 - SN3866; ConvF(7.2, 7.2, 7.2); Calibrated: 6/29/2016; ; Electronics: DAE4 Sn1391
Phantom: SAM with CRP_2016_07_22_middle; Type: QD000P40CD; Serial: TP:1786
Measurement SW: DASY52, Version 52.8 (8); SEMCAD X Version 14.6.10 (7331)

Test Date: 2017-02-27; Ambient Temp: 20.2; Tissue Temp: 21.2

2450 MHz System Verification

Area Scan (7x9x1): Measurement grid: dx=12mm, dy=12mm

Zoom Scan (7x7x7)/Cube 0: Measurement grid: dx=5mm, dy=5mm, dz=5mm

Power Drift = -0.09 dB

Peak SAR (extrapolated) = 29.4 W/kg

SAR(1 g) = 12.9 W/kg; SAR(10 g) = 5.98 W/kg

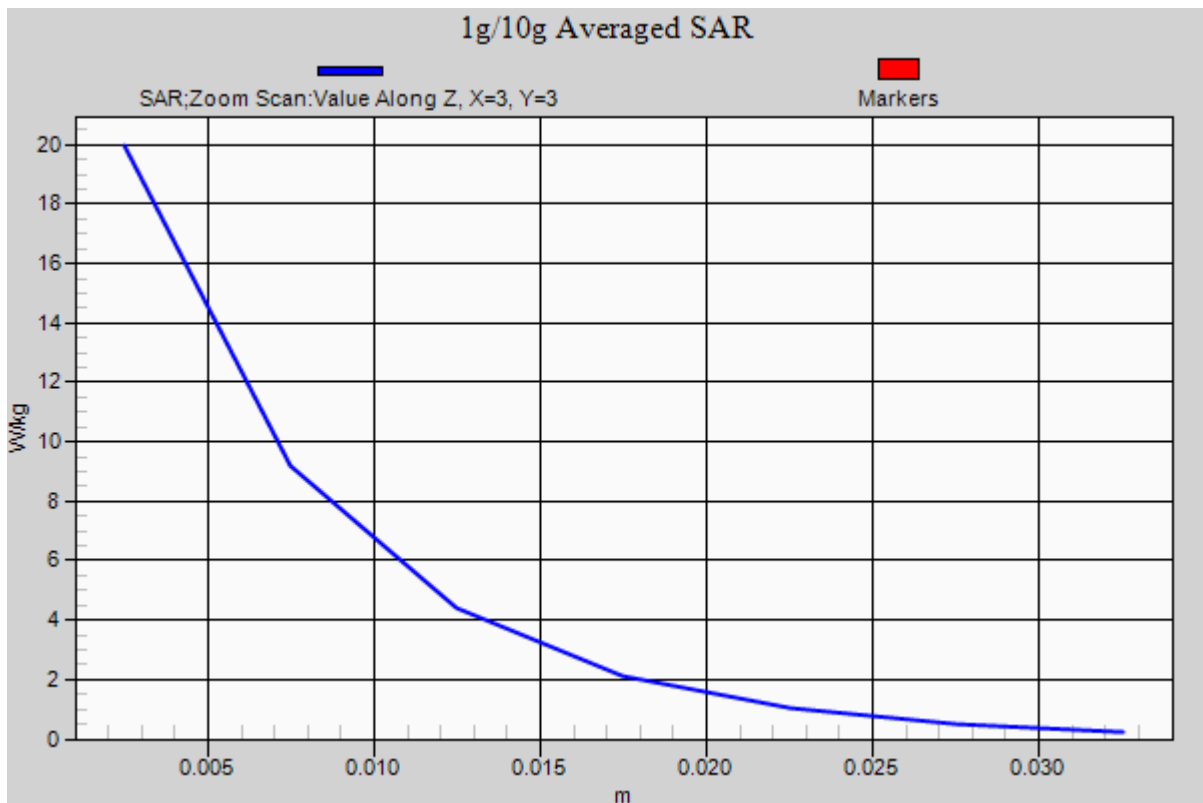

DT&C Co., Ltd.

DUT: DA28; Type: Folder

Communication System: PCS 1900 (0); Frequency: 1880 MHz; Duty Cycle: 1:8.3
Medium parameters used: $f = 1880$ MHz; $\sigma = 1.413$ S/m; $\epsilon_r = 39.268$; $\rho = 1000$ kg/m³
Phantom section: Right Section

DASY5 Configuration:

Probe: EX3DV4 - SN3866; ConvF(7.56, 7.56, 7.56); Calibrated: 6/29/2016; Electronics: DAE4 Sn1391
Phantom: SAM with CRP_2016_07_22_middle; Type: QD000P40CD; Serial: TP:1786
Measurement SW: DASY52, Version 52.8 (8); SEMCAD X Version 14.6.10 (7331)

Test Date: 2017-02-24; Ambient Temp: 21.3; Tissue Temp: 22.6

Right Touch, PCS1900 Ch. 661, Ant Internal, Standard Battery

Area Scan (9x18x1): Measurement grid: dx=15mm, dy=15mm

Zoom Scan (5x5x7)/Cube 0: Measurement grid: dx=8mm, dy=8mm, dz=5mm

Power Drift = 0.03 dB

Peak SAR (extrapolated) = 1.03 W/kg

SAR(1 g) = 0.617 W/kg; SAR(10 g) = 0.341 W/kg

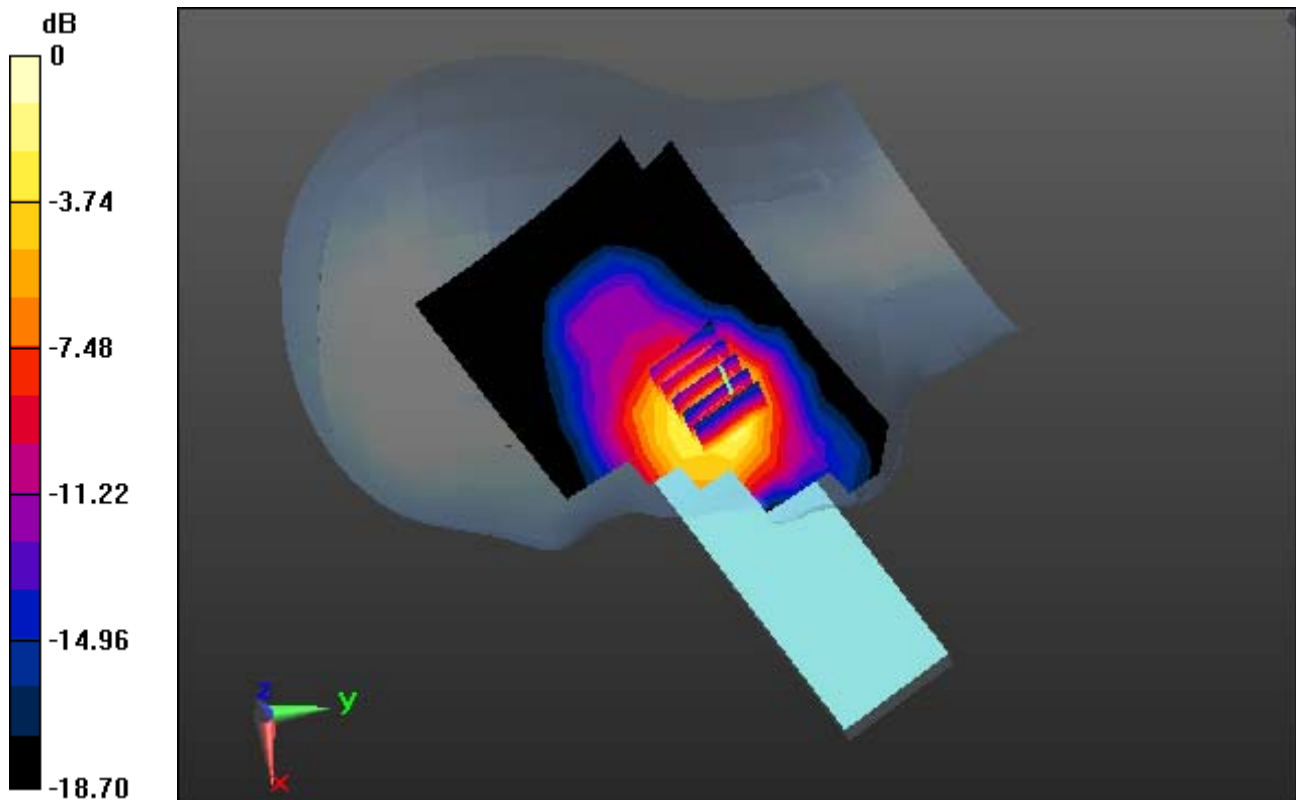

0 dB = 0.775 W/kg

DT&C Co., Ltd.

DUT: DA28; Type: Folder

Communication System: PCS 1900 (0); Frequency: 1880 MHz; Duty Cycle: 1:8.3
Medium parameters used: $f = 1880$ MHz; $\sigma = 1.413$ S/m; $\epsilon_r = 39.268$; $\rho = 1000$ kg/m³
Phantom section: Right Section

DASY5 Configuration:

Probe: EX3DV4 - SN3866; ConvF(7.56, 7.56, 7.56); Calibrated: 6/29/2016; Electronics: DAE4 Sn1391
Phantom: SAM with CRP_2016_07_22_middle; Type: QD000P40CD; Serial: TP:1786
Measurement SW: DASY52, Version 52.8 (8); SEMCAD X Version 14.6.10 (7331)

Test Date: 2017-02-24; Ambient Temp: 21.3; Tissue Temp: 22.6

Right Touch, PCS1900 Ch. 661, Ant Internal, Standard Battery

With Enlarge Plot image

Area Scan (9x18x1): Measurement grid: dx=15mm, dy=15mm

Zoom Scan (5x5x7)/Cube 0: Measurement grid: dx=8mm, dy=8mm, dz=5mm

Power Drift = 0.03 dB

Peak SAR (extrapolated) = 1.03 W/kg

SAR(1 g) = 0.617 W/kg; SAR(10 g) = 0.341 W/kg

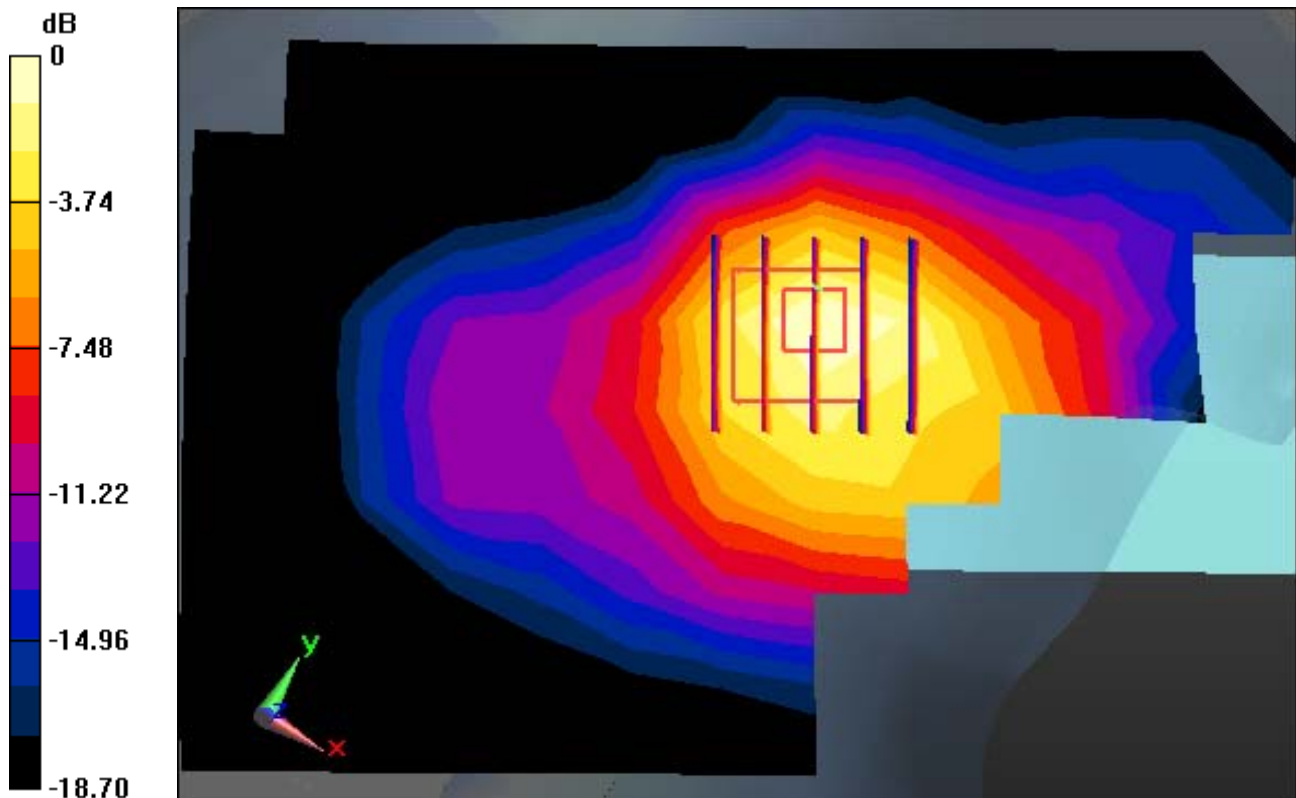

0 dB = 0.775 W/kg

DT&C Co., Ltd.

DUT: DA28; Type: Folder

Communication System: PCS 1900 (0); Frequency: 1880 MHz; Duty Cycle: 1:8.3
Medium parameters used: $f = 1880$ MHz; $\sigma = 1.413$ S/m; $\epsilon_r = 39.268$; $\rho = 1000$ kg/m³
Phantom section: Right Section

DASY5 Configuration:

Probe: EX3DV4 - SN3866; ConvF(7.56, 7.56, 7.56); Calibrated: 6/29/2016; Electronics: DAE4 Sn1391
Phantom: SAM with CRP_2016_07_22_middle; Type: QD000P40CD; Serial: TP:1786
Measurement SW: DASY52, Version 52.8 (8); SEMCAD X Version 14.6.10 (7331)

Test Date: 2017-02-24; Ambient Temp: 21.3; Tissue Temp: 22.6

Right Touch, PCS1900 Ch. 661, Ant Internal, Standard Battery

Area Scan (9x18x1): Measurement grid: dx=15mm, dy=15mm

Zoom Scan (5x5x7)/Cube 0: Measurement grid: dx=8mm, dy=8mm, dz=5mm

Power Drift = 0.03 dB

Peak SAR (extrapolated) = 1.03 W/kg

SAR(1 g) = 0.617 W/kg; SAR(10 g) = 0.341 W/kg

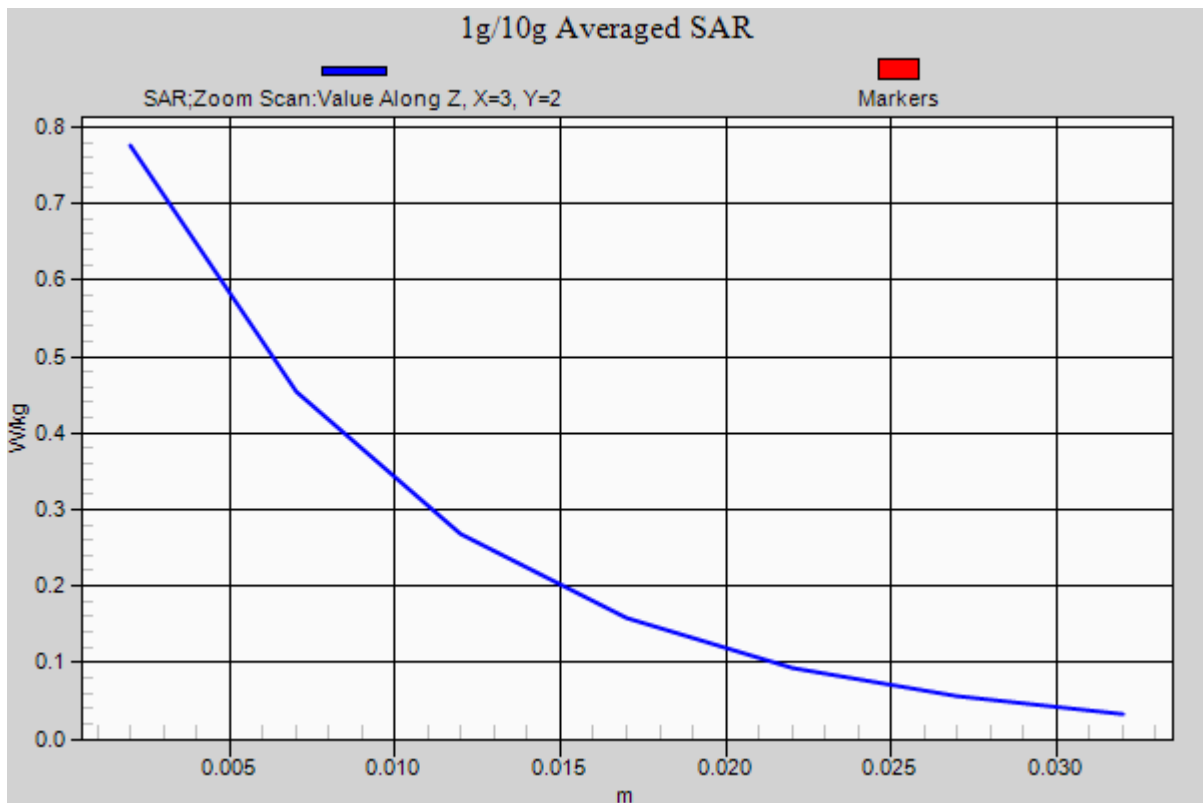

DT&C Co., Ltd.

DUT: DA28; Type: Folder

Communication System: W-LAN (0); Frequency: 2437 MHz; Duty Cycle: 1:1
Medium parameters used: $f = 2437$ MHz; $\sigma = 1.84$ S/m; $\epsilon_r = 38.39$; $\rho = 1000$ kg/m³
Phantom section: Left Section

DASY5 Configuration:

Probe: EX3DV4 - SN3866; ConvF(7.17, 7.17, 7.17); Calibrated: 6/29/2016; Electronics: DAE4 Sn1391
Phantom: SAM with CRP_2016_07_22_middle; Type: QD000P40CD; Serial: TP:1786
Measurement SW: DASY52, Version 52.8 (8); SEMCAD X Version 14.6.10 (7331)

Test Date: 2017-02-27; Ambient Temp: 20.2; Tissue Temp: 21.0

Left Tilt, W-LAN(802.11b) Ch. 6, Ant Internal, Standard Battery

Area Scan (11x22x1): Measurement grid: dx=12mm, dy=12mm

Zoom Scan (7x7x7)/Cube 0: Measurement grid: dx=5mm, dy=5mm, dz=5mm

Power Drift = -0.13 dB

Peak SAR (extrapolated) = 0.0350 W/kg

SAR(1 g) = 0.018 W/kg; SAR(10 g) = 0.00722 W/kg

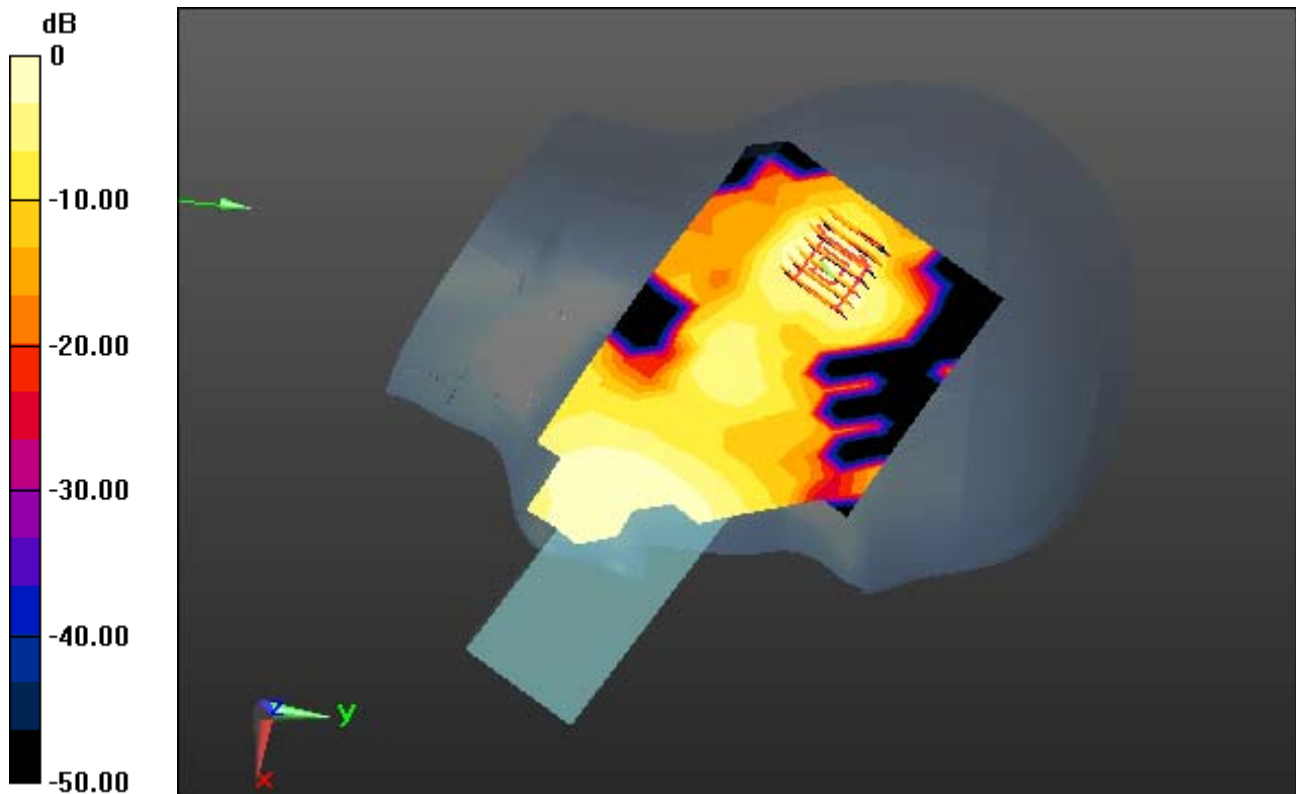

0 dB = 0.0264 W/kg

DT&C Co., Ltd.

DUT: DA28; Type: Folder

Communication System: W-LAN (0); Frequency: 2437 MHz; Duty Cycle: 1:1
Medium parameters used: $f = 2437$ MHz; $\sigma = 1.84$ S/m; $\epsilon_r = 38.39$; $\rho = 1000$ kg/m³
Phantom section: Left Section

DASY5 Configuration:

Probe: EX3DV4 - SN3866; ConvF(7.17, 7.17, 7.17); Calibrated: 6/29/2016; Electronics: DAE4 Sn1391
Phantom: SAM with CRP_2016_07_22_middle; Type: QD000P40CD; Serial: TP:1786
Measurement SW: DASY52, Version 52.8 (8); SEMCAD X Version 14.6.10 (7331)

Test Date: 2017-02-27; Ambient Temp: 20.2; Tissue Temp: 21.0

Left Tilt, W-LAN(802.11b) Ch. 6, Ant Internal, Standard Battery

With Enlarge Plot image

Area Scan (11x22x1): Measurement grid: dx=12mm, dy=12mm

Zoom Scan (7x7x7)/Cube 0: Measurement grid: dx=5mm, dy=5mm, dz=5mm
Power Drift = -0.13 dB

Peak SAR (extrapolated) = 0.0350 W/kg

SAR(1 g) = 0.018 W/kg; SAR(10 g) = 0.00722 W/kg

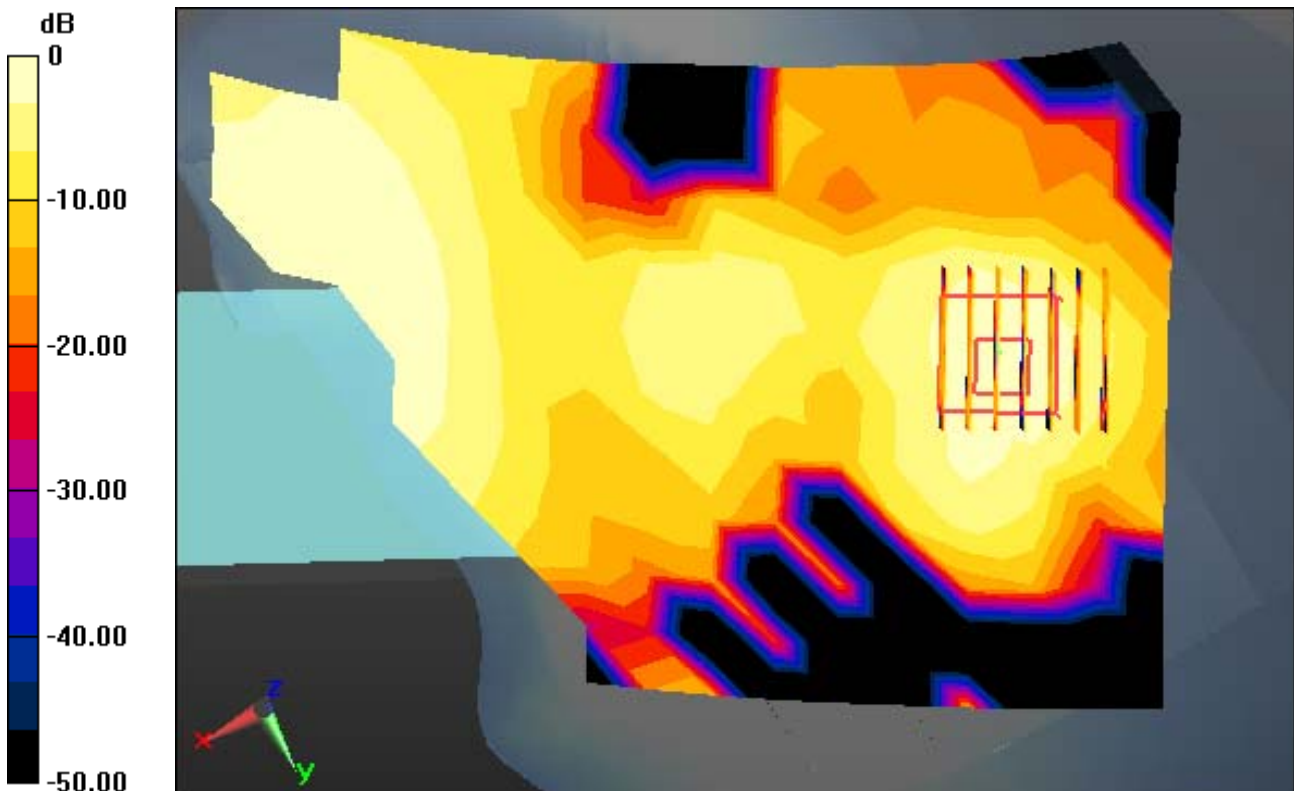

0 dB = 0.0264 W/kg

DT&C Co., Ltd.

DUT: DA28; Type: Folder

Communication System: W-LAN (0); Frequency: 2437 MHz; Duty Cycle: 1:1
Medium parameters used: $f = 2437$ MHz; $\sigma = 1.84$ S/m; $\epsilon_r = 38.39$; $\rho = 1000$ kg/m³
Phantom section: Left Section

DASY5 Configuration:

Probe: EX3DV4 - SN3866; ConvF(7.17, 7.17, 7.17); Calibrated: 6/29/2016; Electronics: DAE4 Sn1391
Phantom: SAM with CRP_2016_07_22_middle; Type: QD000P40CD; Serial: TP:1786
Measurement SW: DASY52, Version 52.8 (8); SEMCAD X Version 14.6.10 (7331)

Test Date: 2017-02-27; Ambient Temp: 20.2; Tissue Temp: 21.0

Left Tilt, W-LAN(802.11b) Ch. 6, Ant Internal, Standard Battery

Area Scan (11x22x1): Measurement grid: dx=12mm, dy=12mm

Zoom Scan (7x7x7)/Cube 0: Measurement grid: dx=5mm, dy=5mm, dz=5mm

Power Drift = -0.13 dB

Peak SAR (extrapolated) = 0.0350 W/kg

SAR(1 g) = 0.018 W/kg; SAR(10 g) = 0.00722 W/kg

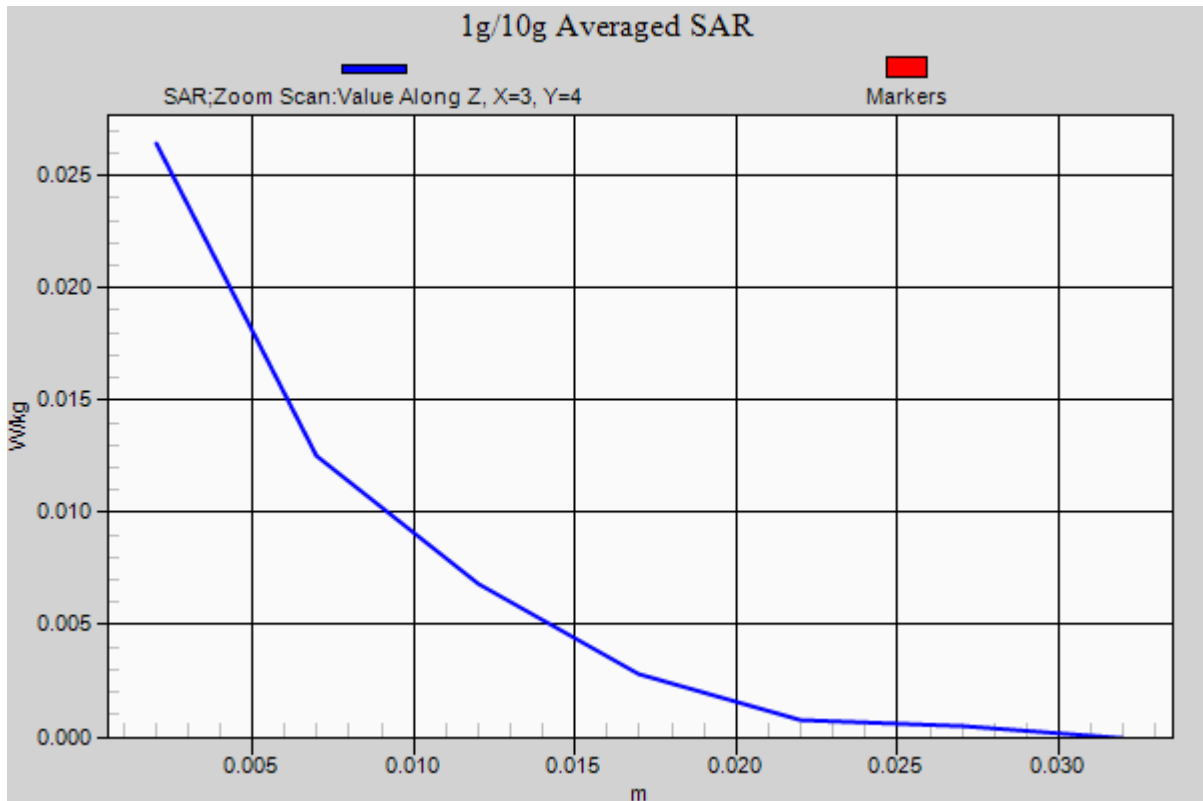

DT&C Co., Ltd.

DUT: DA28; Type: Folder

Communication System: GSM 850 (0); Frequency: 824.2 MHz; Duty Cycle: 1:8.3
Medium parameters used: $f = 824.2$ MHz; $\sigma = 0.98$ S/m; $\epsilon_r = 53.502$; $\rho = 1000$ kg/m³
Phantom section: Flat Section

DASY5 Configuration:

Probe: EX3DV4 - SN3866; ConvF(9.21, 9.21, 9.21); Calibrated: 6/29/2016; Electronics: DAE4 Sn1391
Phantom: SAM with CRP_2016_07_22_middle; Type: QD000P40CD; Serial: TP:1786
Measurement SW: DASY52, Version 52.8 (8); SEMCAD X Version 14.6.10 (7331)

Test Date: 2017-03-14; Ambient Temp; 20.9; Tissue Temp: 21.2

1 cm space from Body, Rear, GSM850 Ch. 128, Ant Internal

Area Scan (8x12x1): Measurement grid: dx=15mm, dy=15mm

Zoom Scan (5x5x7)/Cube 0: Measurement grid: dx=8mm, dy=8mm, dz=5mm

Power Drift = -0.01 dB

Peak SAR (extrapolated) = 1.09 W/kg

SAR(1 g) = 0.776 W/kg; SAR(10 g) = 0.538 W/kg

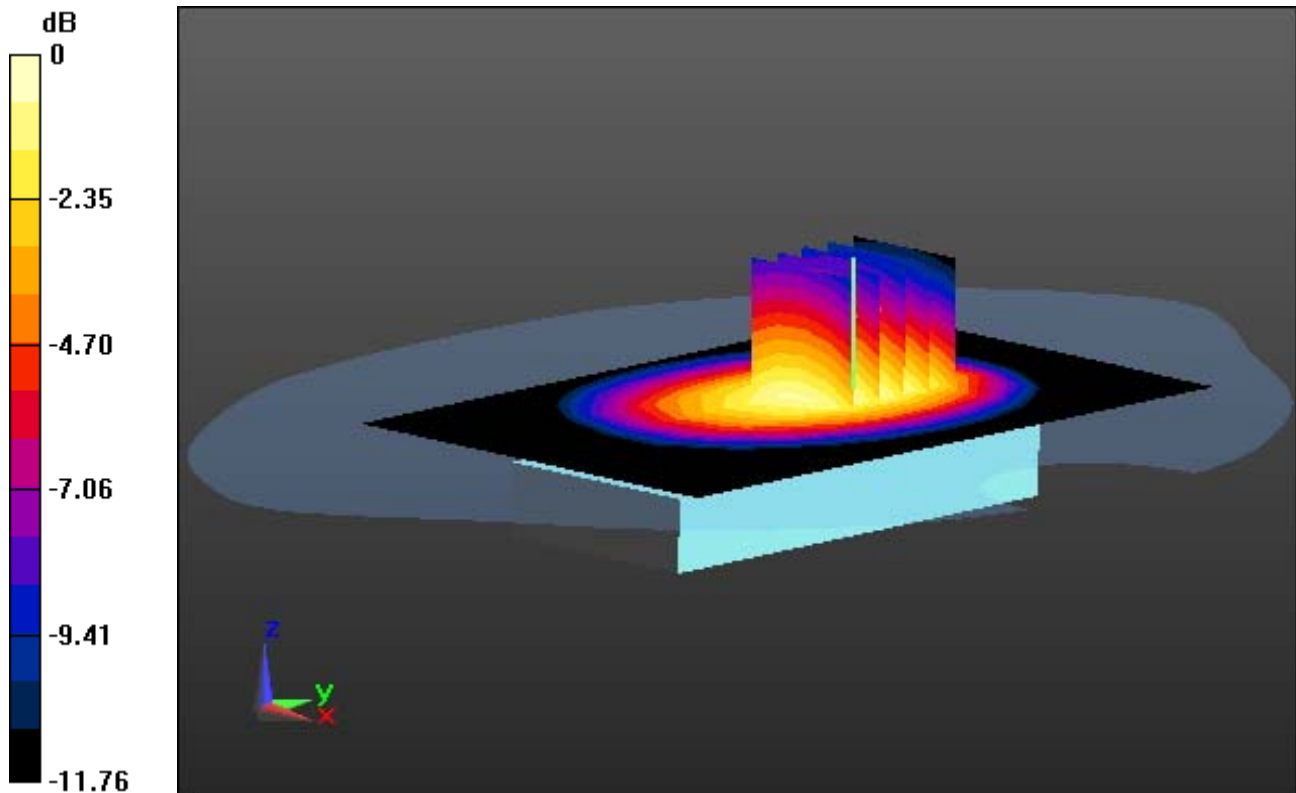

0 dB = 0.949 W/kg

DT&C Co., Ltd.

DUT: DA28; Type: Folder

Communication System: GSM 850 (0); Frequency: 824.2 MHz; Duty Cycle: 1:8.3
Medium parameters used: $f = 824.2$ MHz; $\sigma = 0.98$ S/m; $\epsilon_r = 53.502$; $\rho = 1000$ kg/m³
Phantom section: Flat Section

DASY5 Configuration:

Probe: EX3DV4 - SN3866; ConvF(9.21, 9.21, 9.21); Calibrated: 6/29/2016; Electronics: DAE4 Sn1391
Phantom: SAM with CRP_2016_07_22_middle; Type: QD000P40CD; Serial: TP:1786
Measurement SW: DASY52, Version 52.8 (8); SEMCAD X Version 14.6.10 (7331)

Test Date: 2017-03-14; Ambient Temp; 20.9; Tissue Temp: 21.2

1 cm space from Body, Rear, GSM850 Ch. 128, Ant Internal

With Enlarge plot image

Area Scan (8x12x1): Measurement grid: dx=15mm, dy=15mm

Zoom Scan (5x5x7)/Cube 0: Measurement grid: dx=8mm, dy=8mm, dz=5mm

Power Drift = -0.01 dB

Peak SAR (extrapolated) = 1.09 W/kg

SAR(1 g) = 0.776 W/kg; SAR(10 g) = 0.538 W/kg

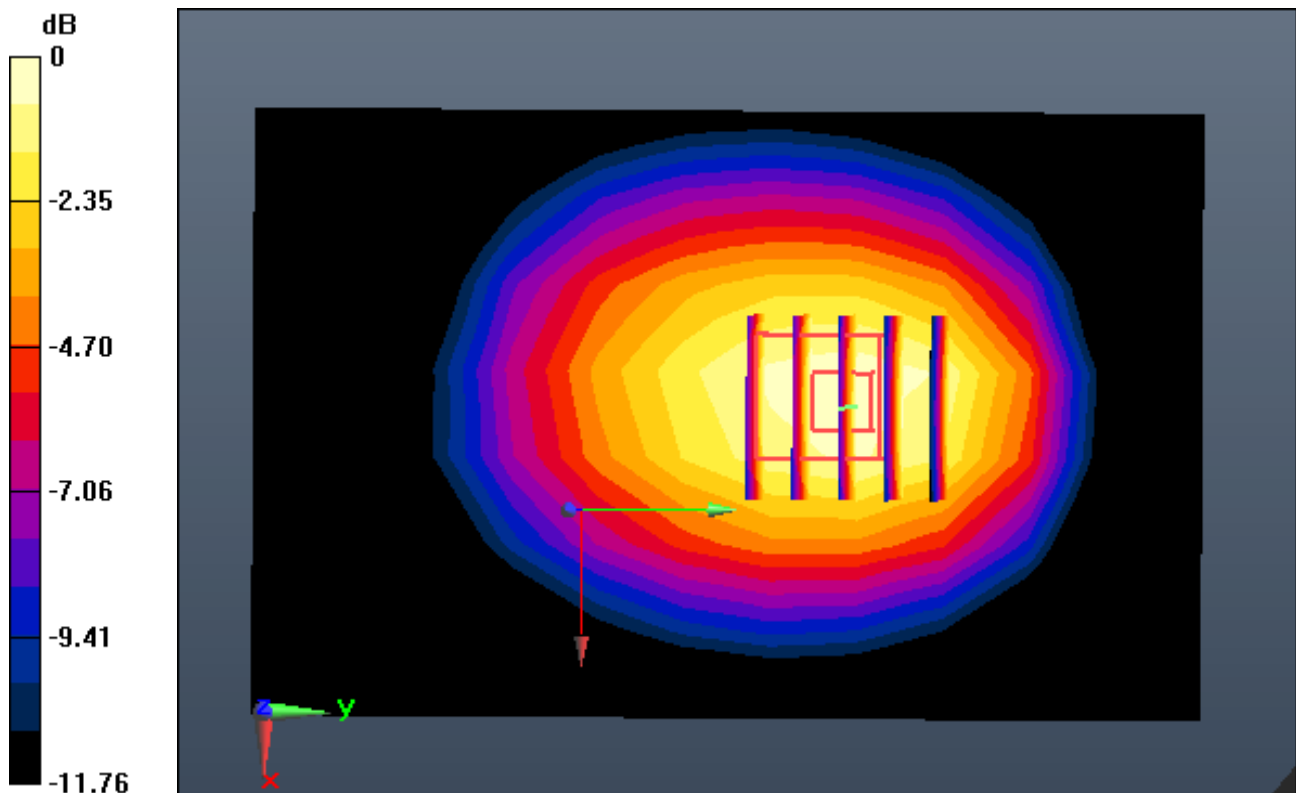

0 dB = 0.949 W/kg

DT&C Co., Ltd.

DUT: DA28; Type: Folder

Communication System: GSM 850 (0); Frequency: 824.2 MHz; Duty Cycle: 1:8.3
Medium parameters used: $f = 824.2$ MHz; $\sigma = 0.98$ S/m; $\epsilon_r = 53.502$; $\rho = 1000$ kg/m³
Phantom section: Flat Section

DASY5 Configuration:

Probe: EX3DV4 - SN3866; ConvF(9.21, 9.21, 9.21); Calibrated: 6/29/2016; Electronics: DAE4 Sn1391
Phantom: SAM with CRP_2016_07_22_middle; Type: QD000P40CD; Serial: TP:1786
Measurement SW: DASY52, Version 52.8 (8); SEMCAD X Version 14.6.10 (7331)

Test Date: 2017-03-14; Ambient Temp; 20.9; Tissue Temp: 21.2

1 cm space from Body, Rear, GSM850 Ch. 128, Ant Internal

Area Scan (8x12x1): Measurement grid: dx=15mm, dy=15mm

Zoom Scan (5x5x7)/Cube 0: Measurement grid: dx=8mm, dy=8mm, dz=5mm

Power Drift = -0.01 dB

Peak SAR (extrapolated) = 1.09 W/kg

SAR(1 g) = 0.776 W/kg; SAR(10 g) = 0.538 W/kg

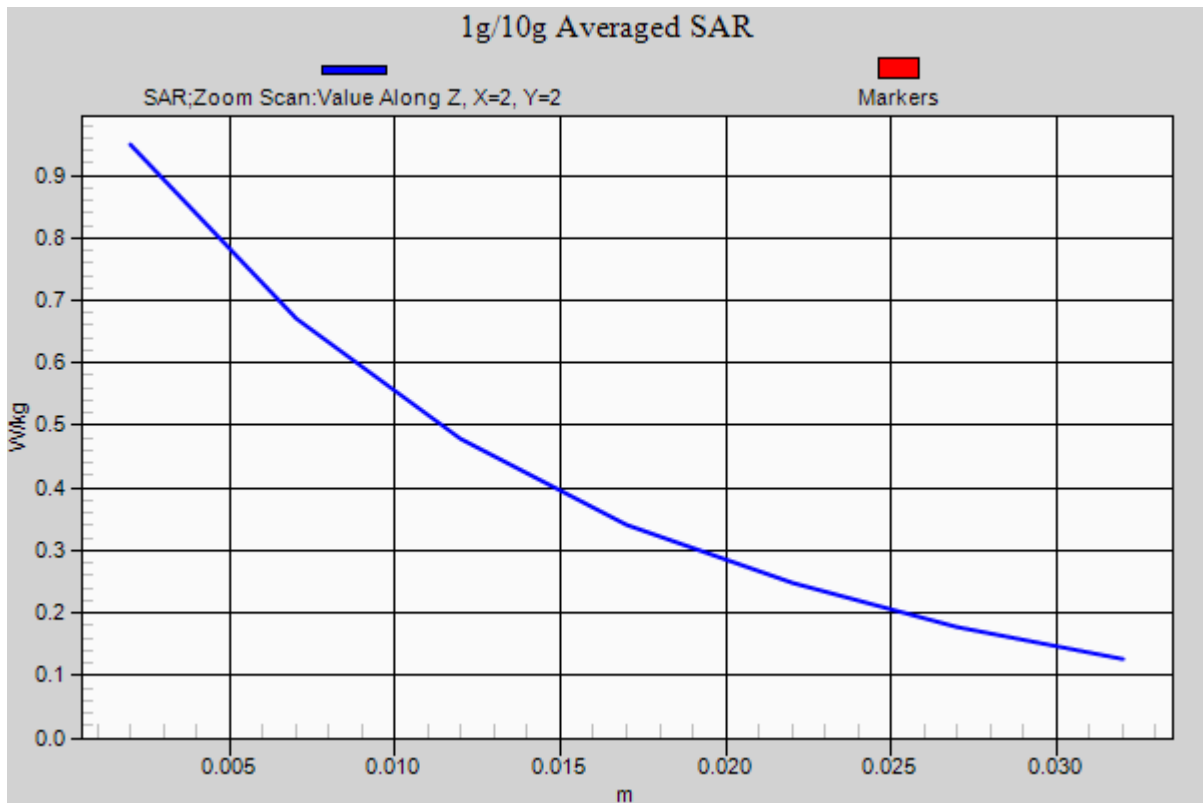

DT&C Co., Ltd.

DUT: DA28; Type: Folder

Communication System: W-LAN (0); Frequency: 2437 MHz; Duty Cycle: 1:1
Medium parameters used: $f = 2437$ MHz; $\sigma = 1.95$ S/m; $\epsilon_r = 51.008$; $\rho = 1000$ kg/m³
Phantom section: Flat Section

DASY5 Configuration:

Probe: EX3DV4 - SN3866; ConvF(7.2, 7.2, 7.2); Calibrated: 6/29/2016; Electronics: DAE4 Sn1391
Phantom: SAM with CRP_2016_07_22_middle; Type: QD000P40CD; Serial: TP:1786
Measurement SW: DASY52, Version 52.8 (8); SEMCAD X Version 14.6.10 (7331)

Test Date: 2017-02-27; Ambient Temp; 20.2; Tissue Temp: 21.2

1 cm space from Body, Rear, WLAN(802.11b) Ch. 6, Ant Internal

Area Scan (10x15x1): Measurement grid: dx=12mm, dy=12mm

Zoom Scan (7x7x7)/Cube 0: Measurement grid: dx=5mm, dy=5mm, dz=5mm

Power Drift = -0.03 dB

Peak SAR (extrapolated) = 0.226 W/kg

SAR(1 g) = 0.113 W/kg; SAR(10 g) = 0.059 W/kg

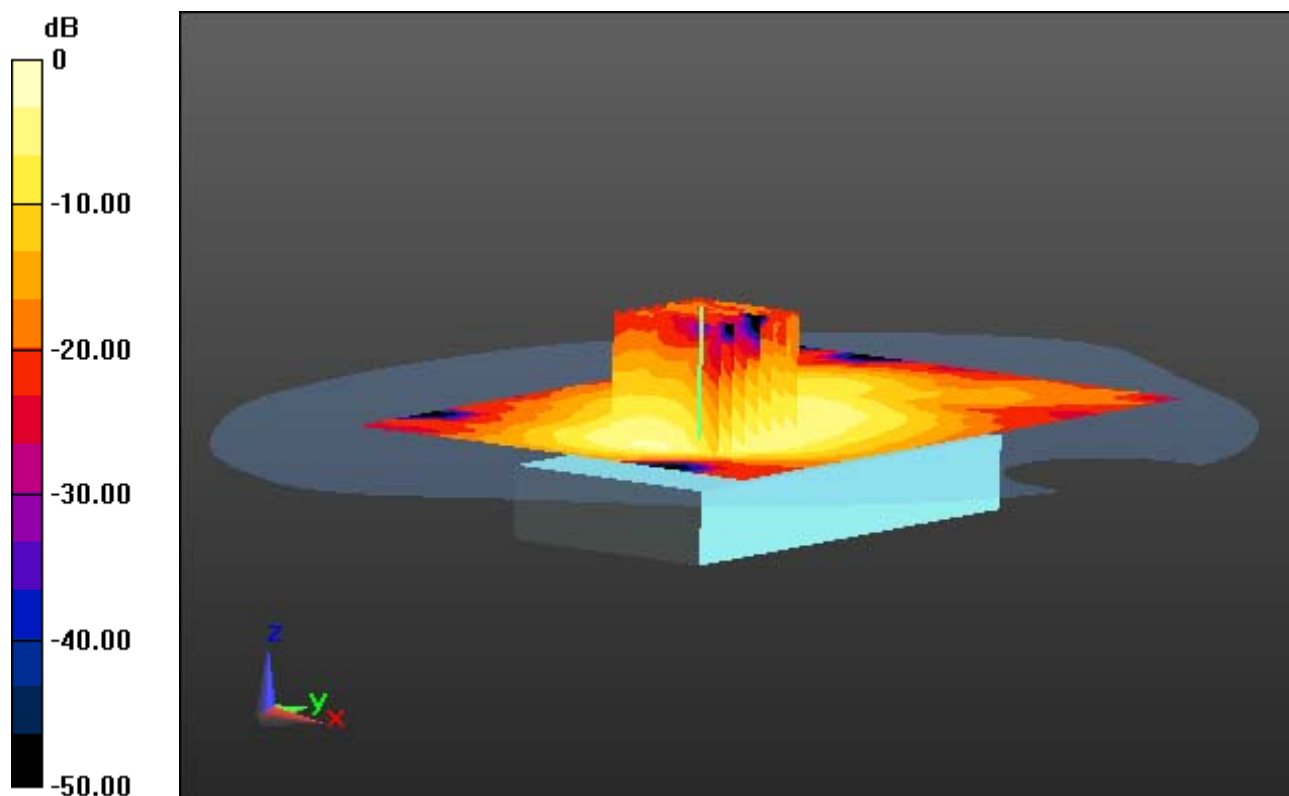

0 dB = 0.162 W/kg

DT&C Co., Ltd.

DUT: DA28; Type: Folder

Communication System: W-LAN (0); Frequency: 2437 MHz; Duty Cycle: 1:1
Medium parameters used: $f = 2437$ MHz; $\sigma = 1.95$ S/m; $\epsilon_r = 51.008$; $\rho = 1000$ kg/m³
Phantom section: Flat Section

DASY5 Configuration:

Probe: EX3DV4 - SN3866; ConvF(7.2, 7.2, 7.2); Calibrated: 6/29/2016; Electronics: DAE4 Sn1391
Phantom: SAM with CRP_2016_07_22_middle; Type: QD000P40CD; Serial: TP:1786
Measurement SW: DASY52, Version 52.8 (8); SEMCAD X Version 14.6.10 (7331)

Test Date: 2017-02-27; Ambient Temp; 20.2; Tissue Temp: 21.2

1 cm space from Body, Rear, WLAN(802.11b) Ch. 6, Ant Internal

With Enlarge Plot image

Area Scan (10x15x1): Measurement grid: dx=12mm, dy=12mm

Zoom Scan (7x7x7)/Cube 0: Measurement grid: dx=5mm, dy=5mm, dz=5mm

Power Drift = -0.03 dB

Peak SAR (extrapolated) = 0.226 W/kg

SAR(1 g) = 0.113 W/kg; SAR(10 g) = 0.059 W/kg

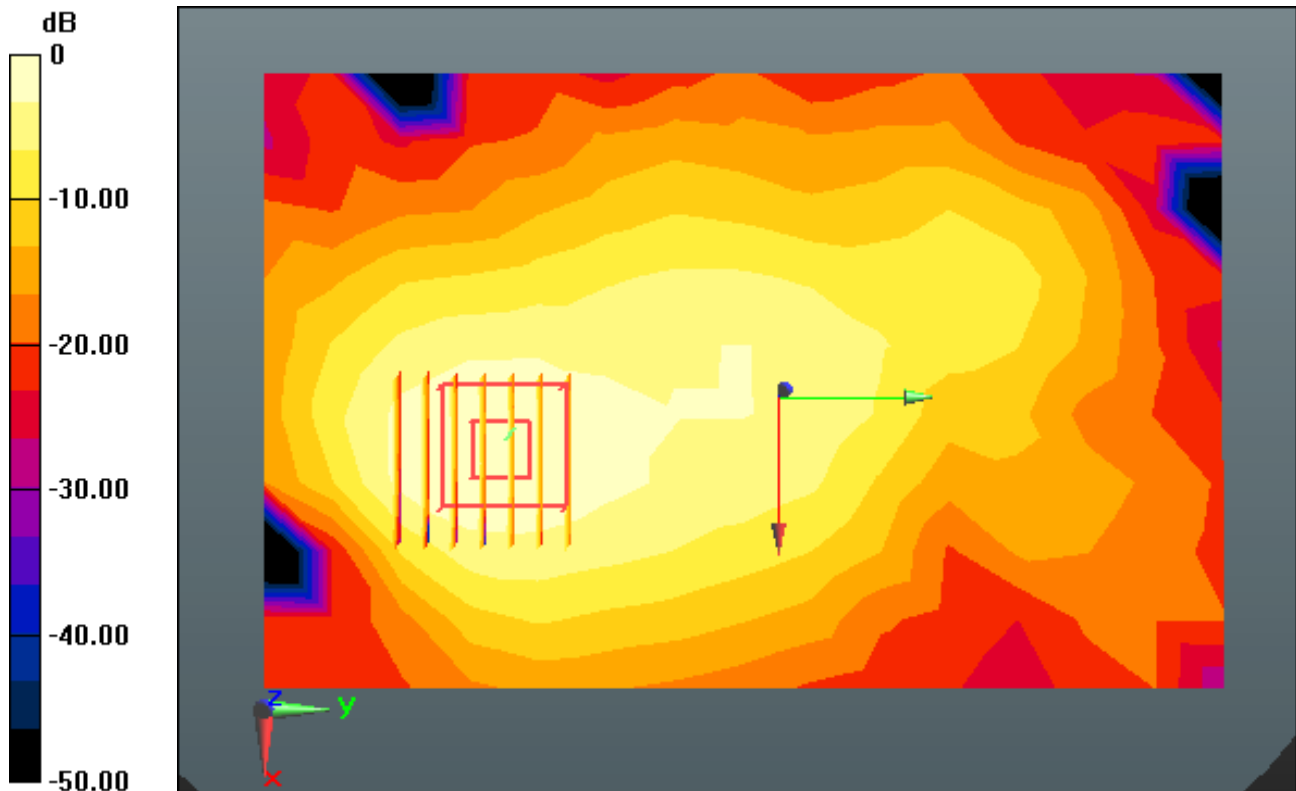

0 dB = 0.162 W/kg

DT&C Co., Ltd.

DUT: DA28; Type: Folder

Communication System: W-LAN (0); Frequency: 2437 MHz; Duty Cycle: 1:1
Medium parameters used: $f = 2437$ MHz; $\sigma = 1.95$ S/m; $\epsilon_r = 51.008$; $\rho = 1000$ kg/m³
Phantom section: Flat Section

DASY5 Configuration:

Probe: EX3DV4 - SN3866; ConvF(7.2, 7.2, 7.2); Calibrated: 6/29/2016; Electronics: DAE4 Sn1391
Phantom: SAM with CRP_2016_07_22_middle; Type: QD000P40CD; Serial: TP:1786
Measurement SW: DASY52, Version 52.8 (8); SEMCAD X Version 14.6.10 (7331)

Test Date: 2017-02-27; Ambient Temp; 20.2; Tissue Temp: 21.2

1 cm space from Body, Rear, WLAN(802.11b) Ch. 6, Ant Internal

Area Scan (10x15x1): Measurement grid: dx=12mm, dy=12mm

Zoom Scan (7x7x7)/Cube 0: Measurement grid: dx=5mm, dy=5mm, dz=5mm

Power Drift = -0.03 dB

Peak SAR (extrapolated) = 0.226 W/kg

SAR(1 g) = 0.113 W/kg; SAR(10 g) = 0.059 W/kg

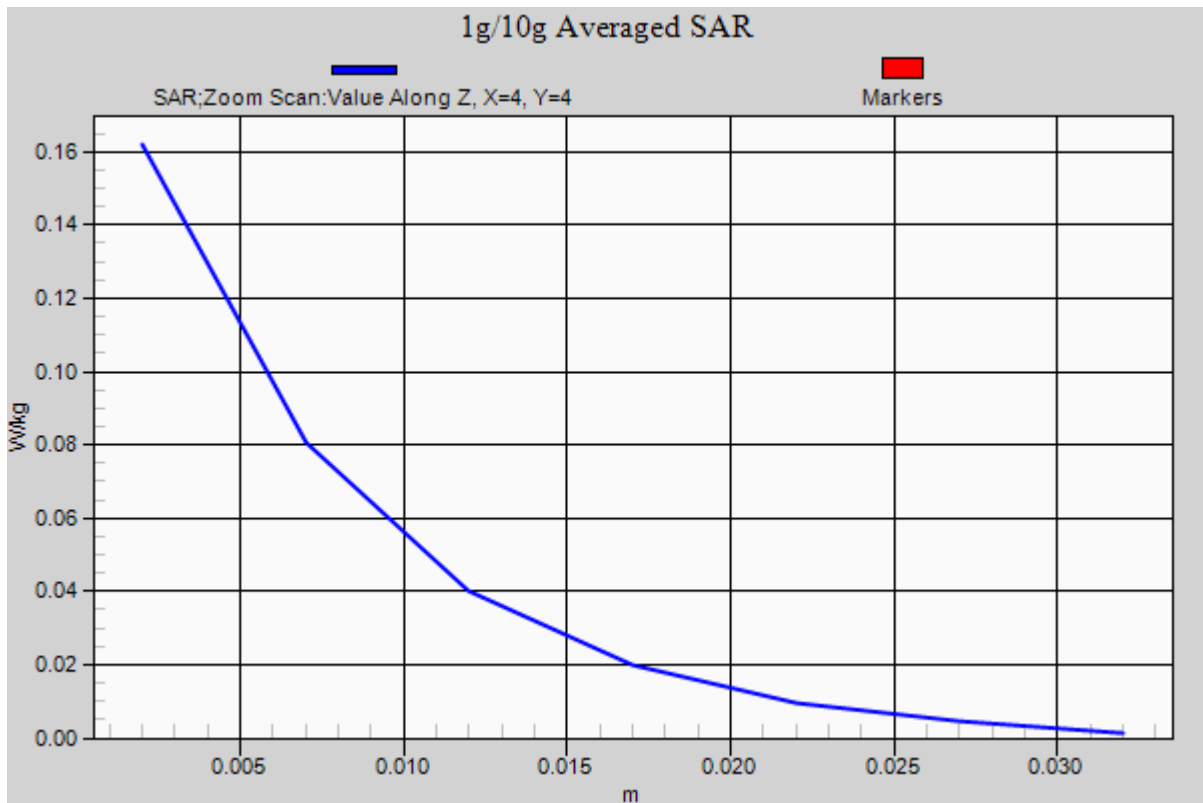

DT&C Co., Ltd.

DUT: DA28; Type: Folder

Communication System: GSM 850_12 (0); Frequency: 848.8 MHz; Duty Cycle: 1:2.075
Medium parameters used: $f = 848.8$ MHz; $\sigma = 1.012$ S/m; $\epsilon_r = 54.137$; $\rho = 1000$ kg/m³
Phantom section: Flat Section

DASY5 Configuration:

Probe: EX3DV4 - SN3866; ConvF(9.21, 9.21, 9.21); Calibrated: 6/29/2016; Electronics: DAE4 Sn1391
Phantom: SAM with CRP_2016_07_22_middle; Type: QD000P40CD; Serial: TP:1786
Measurement SW: DASY52, Version 52.8 (8); SEMCAD X Version 14.6.10 (7331)

Test Date: 2017-03-07; Ambient Temp; 20.8; Tissue Temp: 21.3

1 cm space from Body, Rear, GSM850 GPRS 4Tx Ch. 251, Ant Internal

Area Scan (8x12x1): Measurement grid: dx=15mm, dy=15mm

Zoom Scan (5x5x7)/Cube 0: Measurement grid: dx=8mm, dy=8mm, dz=5mm

Power Drift = 0.02 dB

Peak SAR (extrapolated) = 1.35 W/kg

SAR(1 g) = 0.986 W/kg; SAR(10 g) = 0.677 W/kg

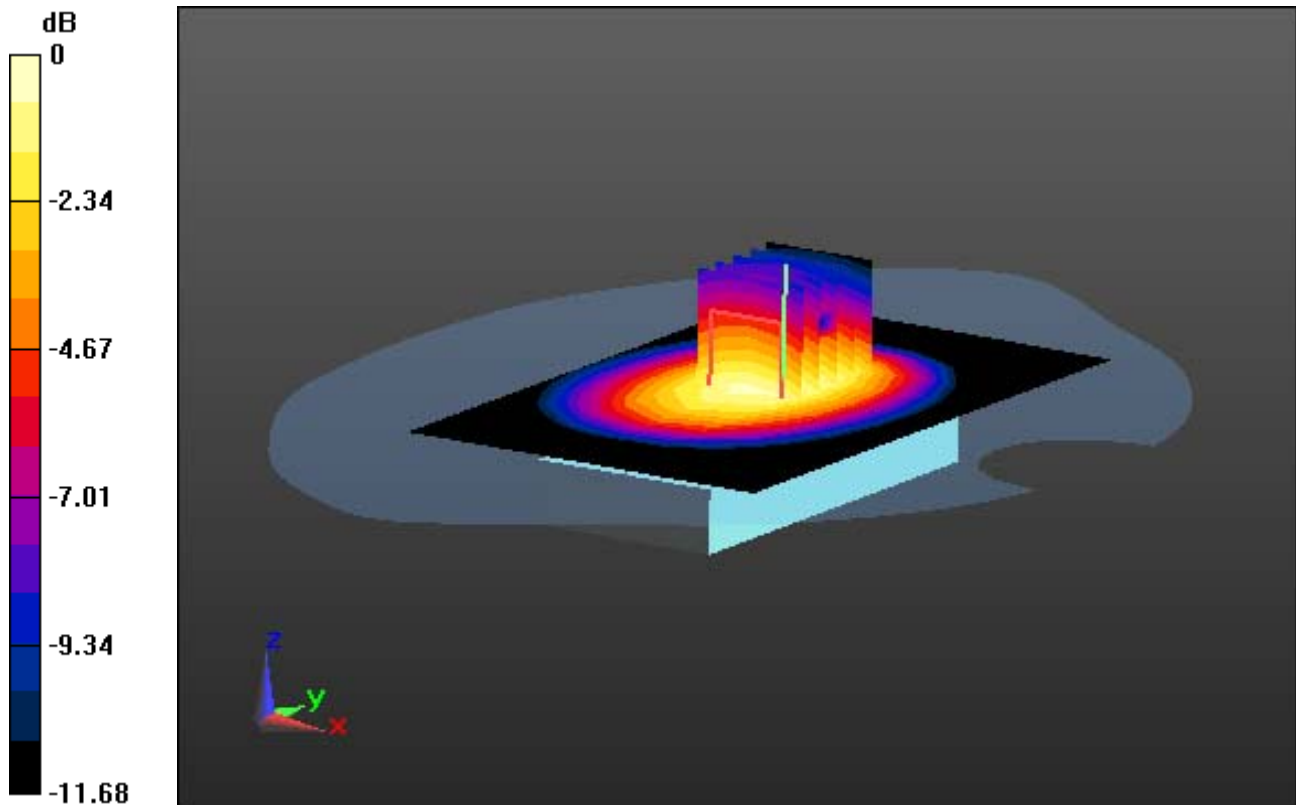

0 dB = 1.18 W/kg

DT&C Co., Ltd.

DUT: DA28; Type: Folder

Communication System: GSM 850_12 (0); Frequency: 848.8 MHz; Duty Cycle: 1:2.075
Medium parameters used: $f = 848.8$ MHz; $\sigma = 1.012$ S/m; $\epsilon_r = 54.137$; $\rho = 1000$ kg/m³
Phantom section: Flat Section

DASY5 Configuration:

Probe: EX3DV4 - SN3866; ConvF(9.21, 9.21, 9.21); Calibrated: 6/29/2016; Electronics: DAE4 Sn1391
Phantom: SAM with CRP_2016_07_22_middle; Type: QD000P40CD; Serial: TP:1786
Measurement SW: DASY52, Version 52.8 (8); SEMCAD X Version 14.6.10 (7331)

Test Date: 2017-03-07; Ambient Temp; 20.8; Tissue Temp: 21.3

1 cm space from Body, Rear, GSM850 GPRS 4Tx Ch. 251, Ant Internal

Area Scan (8x12x1): Measurement grid: dx=15mm, dy=15mm

Zoom Scan (5x5x7)/Cube 0: Measurement grid: dx=8mm, dy=8mm, dz=5mm

Power Drift = 0.02 dB

Peak SAR (extrapolated) = 1.35 W/kg

SAR(1 g) = 0.986 W/kg; SAR(10 g) = 0.677 W/kg

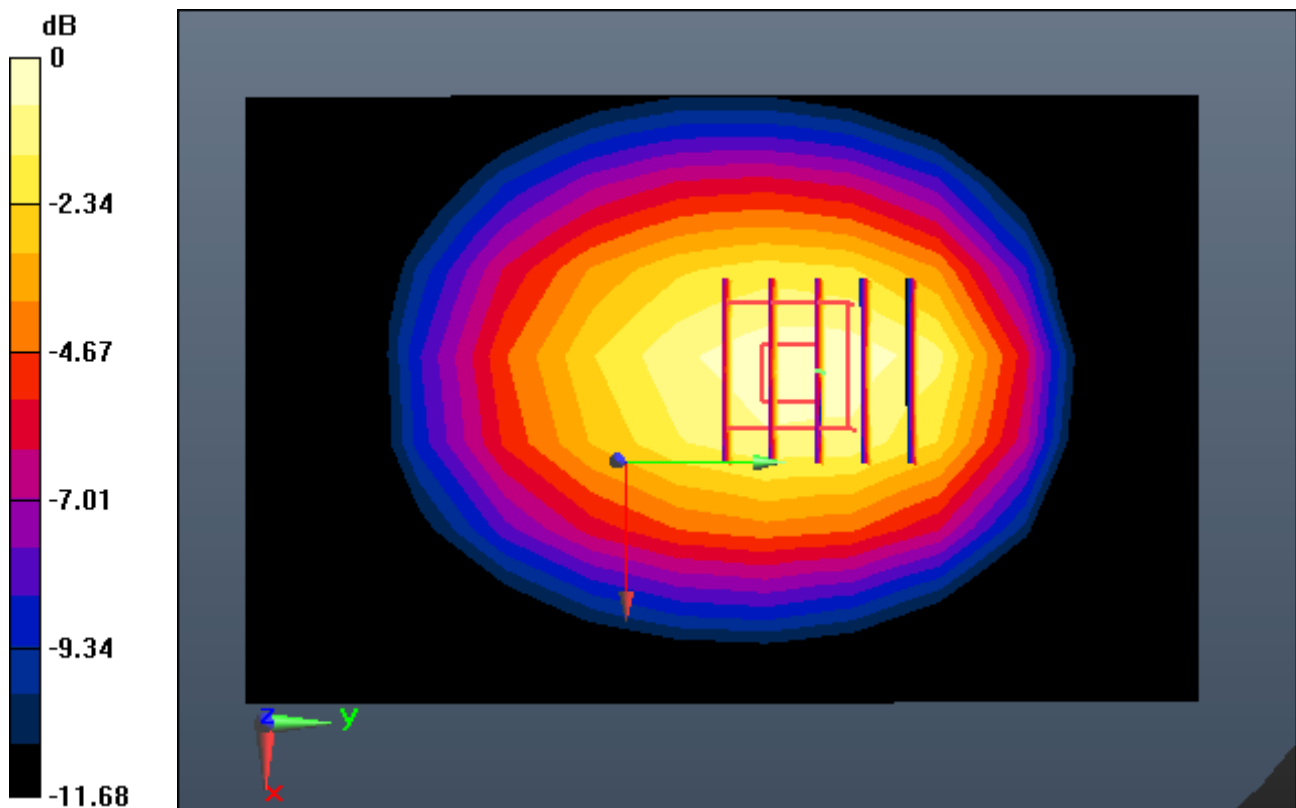

0 dB = 1.18 W/kg

DT&C Co., Ltd.

DUT: DA28; Type: Folder

Communication System: GSM 850_12 (0); Frequency: 848.8 MHz; Duty Cycle: 1:2.075
Medium parameters used: $f = 848.8$ MHz; $\sigma = 1.012$ S/m; $\epsilon_r = 54.137$; $\rho = 1000$ kg/m³
Phantom section: Flat Section

DASY5 Configuration:

Probe: EX3DV4 - SN3866; ConvF(9.21, 9.21, 9.21); Calibrated: 6/29/2016; Electronics: DAE4 Sn1391
Phantom: SAM with CRP_2016_07_22_middle; Type: QD000P40CD; Serial: TP:1786
Measurement SW: DASY52, Version 52.8 (8); SEMCAD X Version 14.6.10 (7331)

Test Date: 2017-03-07; Ambient Temp; 20.8; Tissue Temp: 21.3

1 cm space from Body, Rear, GSM850 GPRS 4Tx Ch. 251, Ant Internal

Area Scan (8x12x1): Measurement grid: dx=15mm, dy=15mm

Zoom Scan (5x5x7)/Cube 0: Measurement grid: dx=8mm, dy=8mm, dz=5mm

Power Drift = 0.02 dB

Peak SAR (extrapolated) = 1.35 W/kg

SAR(1 g) = 0.986 W/kg; SAR(10 g) = 0.677 W/kg

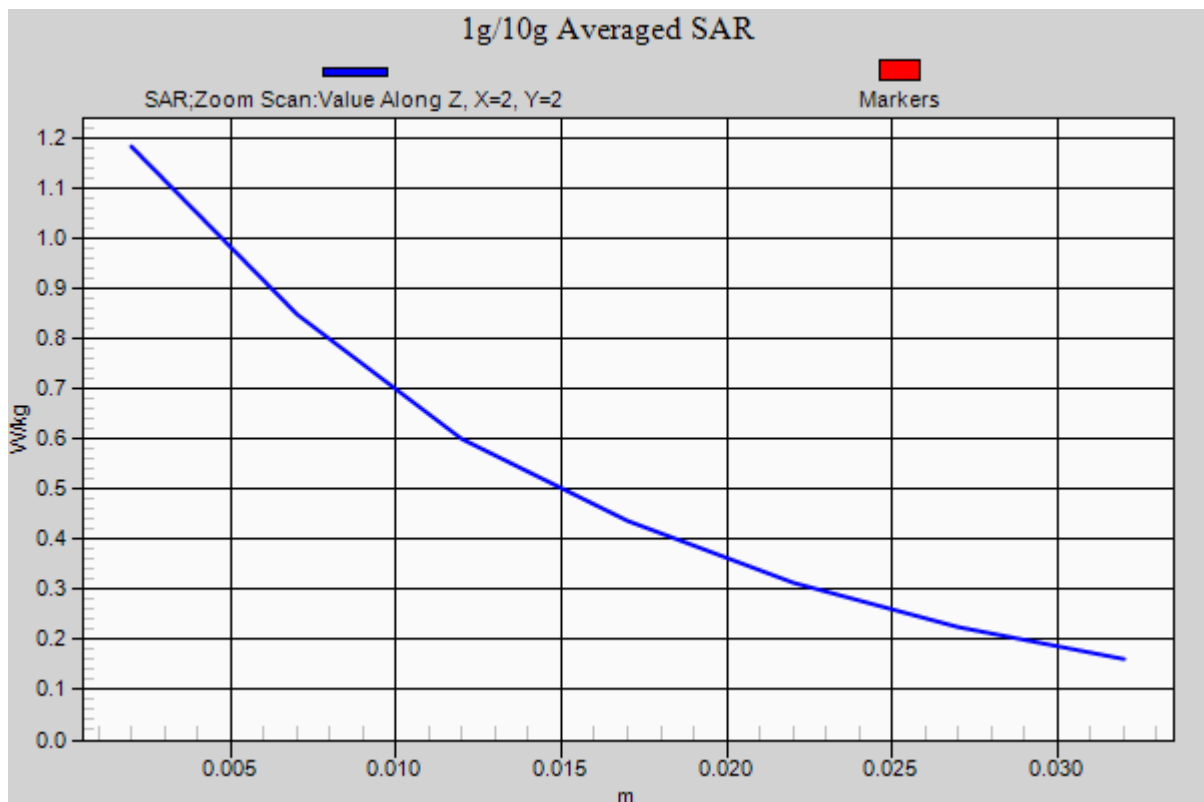

DT&C Co., Ltd.

DUT: DA28; Type: Folder

Communication System: GSM 850 (0); Frequency: 836.6 MHz; Duty Cycle: 1:8.3
Medium parameters used: $f = 836.6$ MHz; $\sigma = 0.908$ S/m; $\epsilon_r = 42.223$; $\rho = 1000$ kg/m³
Phantom section: Left Section

DASY5 Configuration:

Probe: EX3DV4 - SN3866; ConvF(9.36, 9.36, 9.36); Calibrated: 6/29/2016; Electronics: DAE4 Sn1391
Phantom: SAM with CRP_2016_07_22_middle; Type: QD000P40CD; Serial: TP:1786
Measurement SW: DASY52, Version 52.8 (8); SEMCAD X Version 14.6.10 (7331)

Test Date: 2017-03-13; Ambient Temp: 21.0; Tissue Temp: 21.9

Left Touch, GSM850 Ch. 190, Ant Internal, Standard Battery

Area Scan (9x18x1): Measurement grid: dx=15mm, dy=15mm

Zoom Scan (5x5x7)/Cube 0: Measurement grid: dx=8mm, dy=8mm, dz=5mm

Power Drift = -0.05 dB

Peak SAR (extrapolated) = 0.542 W/kg

SAR(1 g) = 0.407 W/kg; SAR(10 g) = 0.290 W/kg

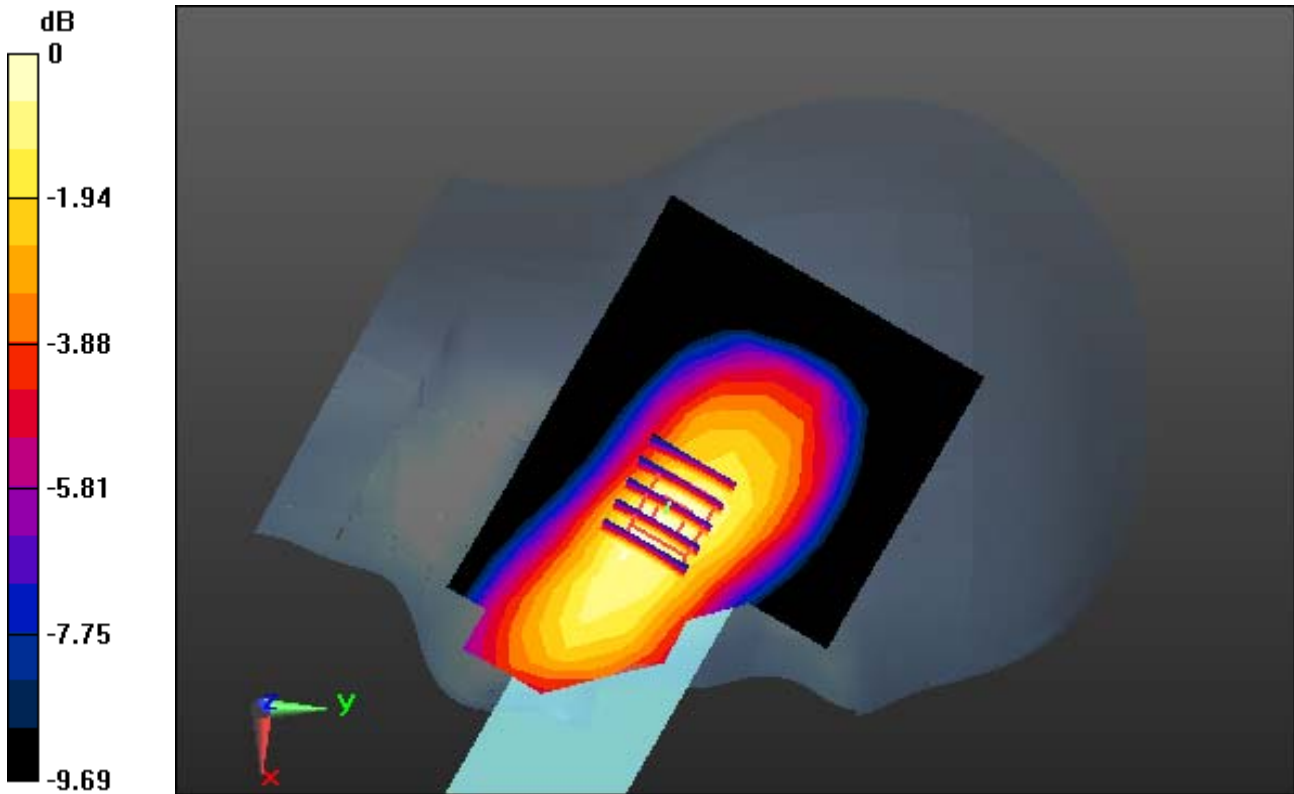

0 dB = 0.480 W/kg

DT&C Co., Ltd.

DUT: DA28; Type: Folder

Communication System: GSM 850 (0); Frequency: 836.6 MHz; Duty Cycle: 1:8.3
Medium parameters used: $f = 836.6$ MHz; $\sigma = 0.908$ S/m; $\epsilon_r = 42.223$; $\rho = 1000$ kg/m³
Phantom section: Left Section

DASY5 Configuration:

Probe: EX3DV4 - SN3866; ConvF(9.36, 9.36, 9.36); Calibrated: 6/29/2016; Electronics: DAE4 Sn1391
Phantom: SAM with CRP_2016_07_22_middle; Type: QD000P40CD; Serial: TP:1786
Measurement SW: DASY52, Version 52.8 (8); SEMCAD X Version 14.6.10 (7331)

Test Date: 2017-03-13; Ambient Temp: 21.0; Tissue Temp: 21.9

Left Touch, GSM850 Ch. 190, Ant Internal, Standard Battery

With Enlarge plot image

Area Scan (9x18x1): Measurement grid: dx=15mm, dy=15mm

Zoom Scan (5x5x7)/Cube 0: Measurement grid: dx=8mm, dy=8mm, dz=5mm

Power Drift = -0.05 dB

Peak SAR (extrapolated) = 0.542 W/kg

SAR(1 g) = 0.407 W/kg; SAR(10 g) = 0.290 W/kg

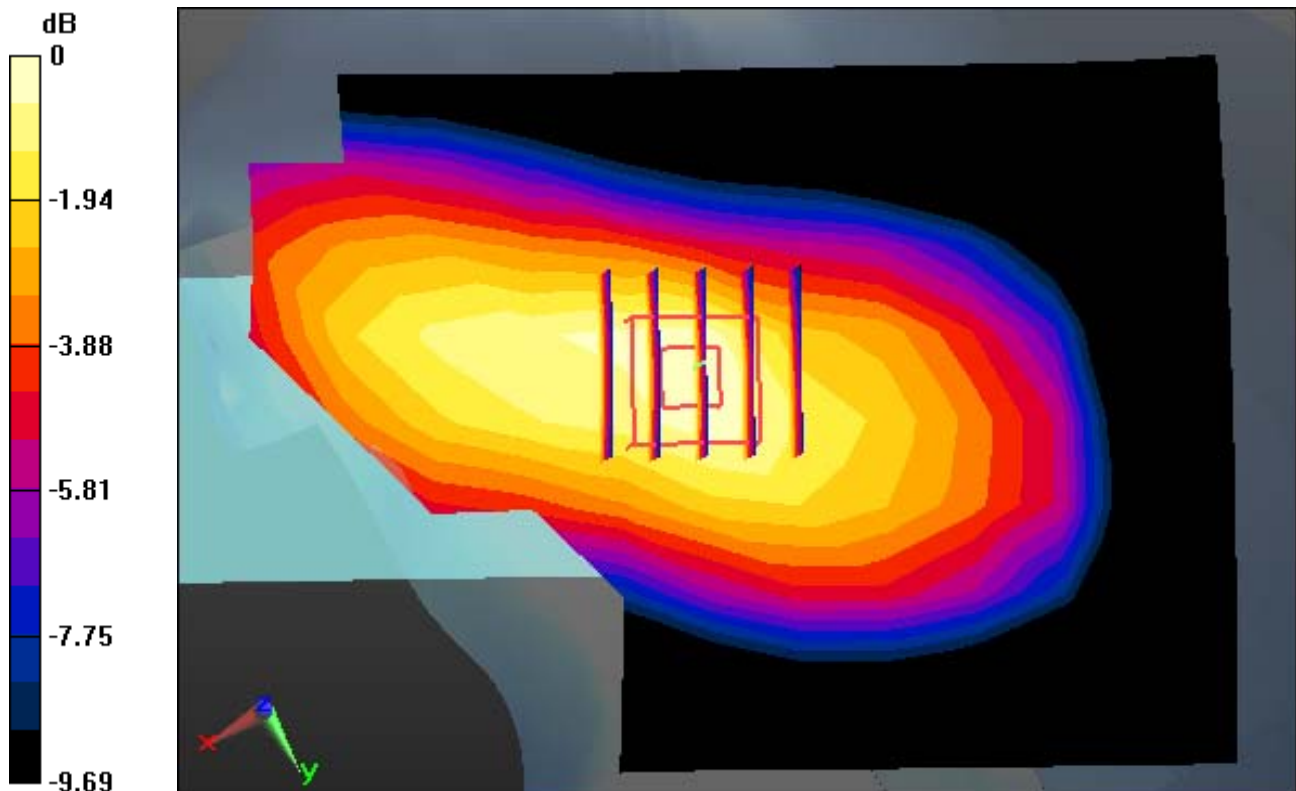

0 dB = 0.480 W/kg

DT&C Co., Ltd.

DUT: DA28; Type: Folder

Communication System: GSM 850 (0); Frequency: 836.6 MHz; Duty Cycle: 1:8.3
Medium parameters used: $f = 836.6$ MHz; $\sigma = 0.908$ S/m; $\epsilon_r = 42.223$; $\rho = 1000$ kg/m³
Phantom section: Left Section

DASY5 Configuration:

Probe: EX3DV4 - SN3866; ConvF(9.36, 9.36, 9.36); Calibrated: 6/29/2016; Electronics: DAE4 Sn1391
Phantom: SAM with CRP_2016_07_22_middle; Type: QD000P40CD; Serial: TP:1786
Measurement SW: DASY52, Version 52.8 (8); SEMCAD X Version 14.6.10 (7331)

Test Date: 2017-03-13; Ambient Temp: 21.0; Tissue Temp: 21.9

Left Touch, GSM850 Ch. 190, Ant Internal, Standard Battery

Area Scan (9x18x1): Measurement grid: dx=15mm, dy=15mm

Zoom Scan (5x5x7)/Cube 0: Measurement grid: dx=8mm, dy=8mm, dz=5mm

Power Drift = -0.05 dB

Peak SAR (extrapolated) = 0.542 W/kg

SAR(1 g) = 0.407 W/kg; SAR(10 g) = 0.290 W/kg

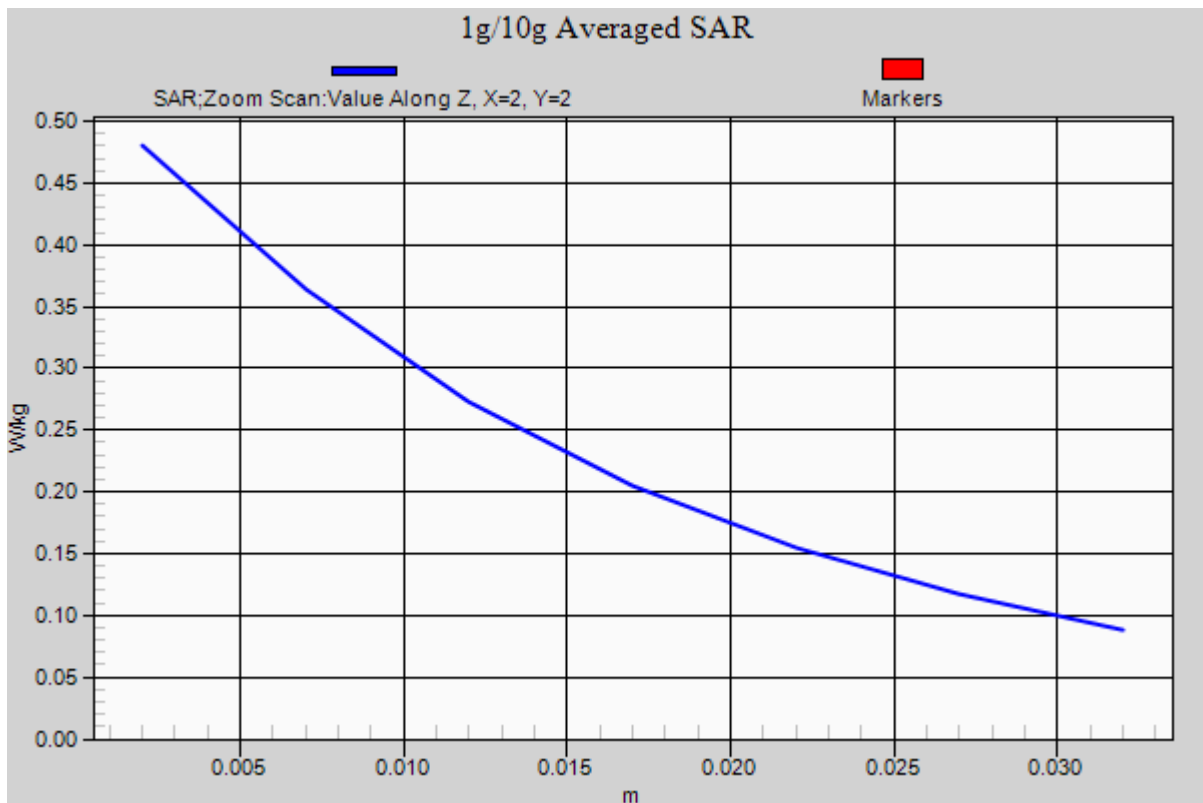

DT&C Co., Ltd.

DUT: DA28; Type: Folder

Communication System: GSM 850_12 (0); Frequency: 836.6 MHz; Duty Cycle: 1:2.077
Medium parameters used: $f = 836.6$ MHz; $\sigma = 0.908$ S/m; $\epsilon_r = 42.223$; $\rho = 1000$ kg/m³
Phantom section: Left Section

DASY5 Configuration:

Probe: EX3DV4 - SN3866; ConvF(9.36, 9.36, 9.36); Calibrated: 6/29/2016; Electronics: DAE4 Sn1391
Phantom: SAM with CRP_2016_07_22_middle; Type: QD000P40CD; Serial: TP:1786
Measurement SW: DASY52, Version 52.8 (8); SEMCAD X Version 14.6.10 (7331)

Test Date: 2017-03-13; Ambient Temp: 21.0; Tissue Temp: 21.9

Left Touch, GSM850 GPRS 4Tx Ch. 190, Ant Internal, Standard Battery

Area Scan (9x18x1): Measurement grid: dx=15mm, dy=15mm

Zoom Scan (5x5x7)/Cube 0: Measurement grid: dx=8mm, dy=8mm, dz=5mm

Power Drift = 0.05 dB

Peak SAR (extrapolated) = 0.578 W/kg

SAR(1 g) = 0.435 W/kg; SAR(10 g) = 0.303 W/kg

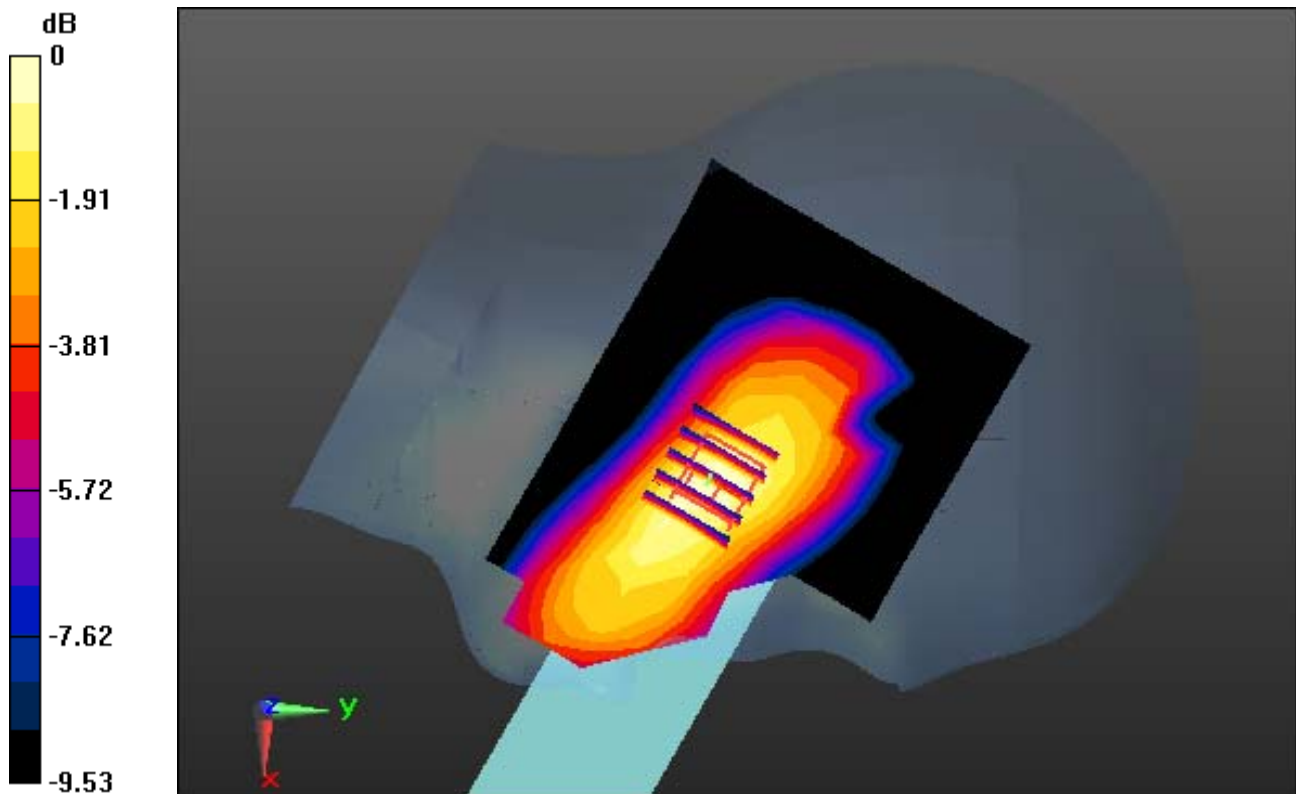

0 dB = 0.502 W/kg

DT&C Co., Ltd.

DUT: DA28; Type: Folder

Communication System: GSM 850_12 (0); Frequency: 836.6 MHz; Duty Cycle: 1:2.075
Medium parameters used: $f = 836.6$ MHz; $\sigma = 0.908$ S/m; $\epsilon_r = 42.223$; $\rho = 1000$ kg/m³
Phantom section: Left Section

DASY5 Configuration:

Probe: EX3DV4 - SN3866; ConvF(9.36, 9.36, 9.36); Calibrated: 6/29/2016; Electronics: DAE4 Sn1391
Phantom: SAM with CRP_2016_07_22_middle; Type: QD000P40CD; Serial: TP:1786
Measurement SW: DASY52, Version 52.8 (8); SEMCAD X Version 14.6.10 (7331)

Test Date: 2017-03-13; Ambient Temp: 21.0; Tissue Temp: 21.9

Left Touch, GSM850 GPRS 4Tx Ch. 190, Ant Internal, Standard Battery

With Enlarge plot image

Area Scan (9x18x1): Measurement grid: dx=15mm, dy=15mm

Zoom Scan (5x5x7)/Cube 0: Measurement grid: dx=8mm, dy=8mm, dz=5mm

Power Drift = 0.05 dB

Peak SAR (extrapolated) = 0.578 W/kg

SAR(1 g) = 0.435 W/kg; SAR(10 g) = 0.303 W/kg

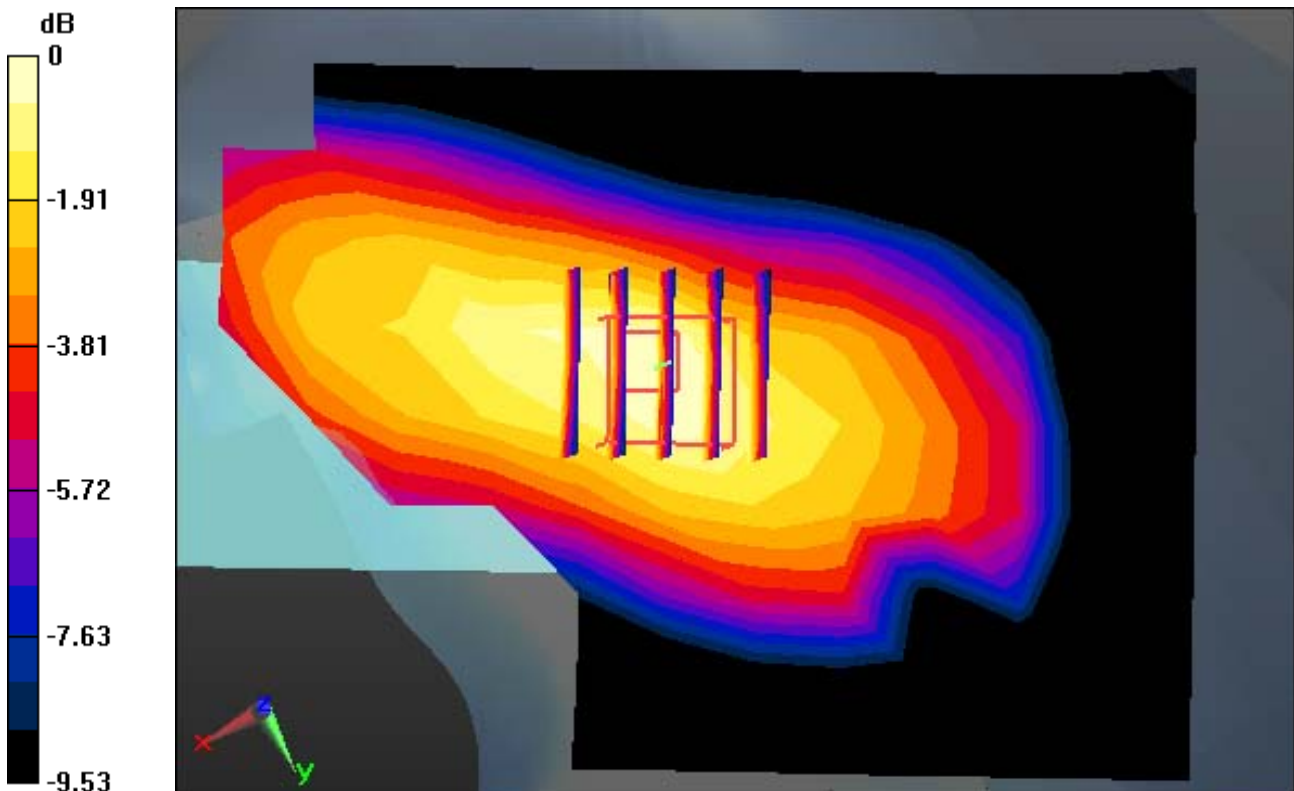

0 dB = 0.502 W/kg

DT&C Co., Ltd.

DUT: DA28; Type: Folder

Communication System: GSM 850_12 (0); Frequency: 836.6 MHz; Duty Cycle: 1:2.075
Medium parameters used: $f = 836.6$ MHz; $\sigma = 0.908$ S/m; $\epsilon_r = 42.223$; $\rho = 1000$ kg/m³
Phantom section: Left Section

DASY5 Configuration:

Probe: EX3DV4 - SN3866; ConvF(9.36, 9.36, 9.36); Calibrated: 6/29/2016; Electronics: DAE4 Sn1391
Phantom: SAM with CRP_2016_07_22_middle; Type: QD000P40CD; Serial: TP:1786
Measurement SW: DASY52, Version 52.8 (8); SEMCAD X Version 14.6.10 (7331)

Test Date: 2017-03-13; Ambient Temp: 21.0; Tissue Temp: 21.9

Left Touch, GSM850 GPRS 4Tx Ch. 190, Ant Internal, Standard Battery

Area Scan (9x18x1): Measurement grid: dx=15mm, dy=15mm

Zoom Scan (5x5x7)/Cube 0: Measurement grid: dx=8mm, dy=8mm, dz=5mm

Power Drift = 0.05 dB

Peak SAR (extrapolated) = 0.578 W/kg

SAR(1 g) = 0.435 W/kg; SAR(10 g) = 0.303 W/kg

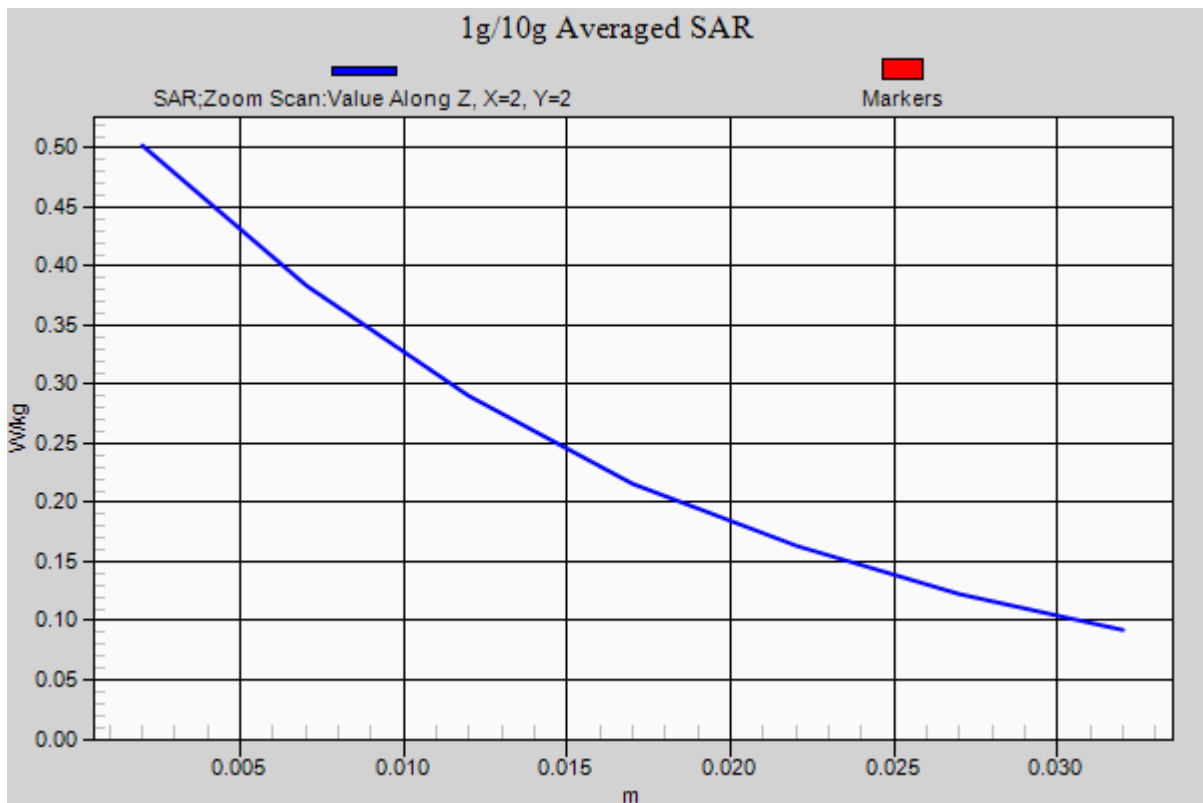

DT&C Co., Ltd.

DUT: DA28; Type: Folder

Communication System: GSM 850_12 (0); Frequency: 848.8 MHz; Duty Cycle: 1:2.075
Medium parameters used: $f = 848.8$ MHz; $\sigma = 1.003$ S/m; $\epsilon_r = 53.398$; $\rho = 1000$ kg/m³
Phantom section: Flat Section

DASY5 Configuration:

Probe: EX3DV4 - SN3866; ConvF(9.21, 9.21, 9.21); Calibrated: 6/29/2016; Electronics: DAE4 Sn1391
Phantom: SAM with CRP_2016_07_22_middle; Type: QD000P40CD; Serial: TP:1786
Measurement SW: DASY52, Version 52.8 (8); SEMCAD X Version 14.6.10 (7331)

Test Date: 2017-03-14; Ambient Temp; 20.9; Tissue Temp: 21.2

1 cm space from Body, Rear, GSM850 GPRS 4Tx Ch. 251, Ant Internal

Area Scan (8x12x1): Measurement grid: dx=15mm, dy=15mm

Zoom Scan (5x5x7)/Cube 0: Measurement grid: dx=8mm, dy=8mm, dz=5mm

Power Drift = 0.03 dB

Peak SAR (extrapolated) = 1.23 W/kg

SAR(1 g) = 0.886 W/kg; SAR(10 g) = 0.621 W/kg

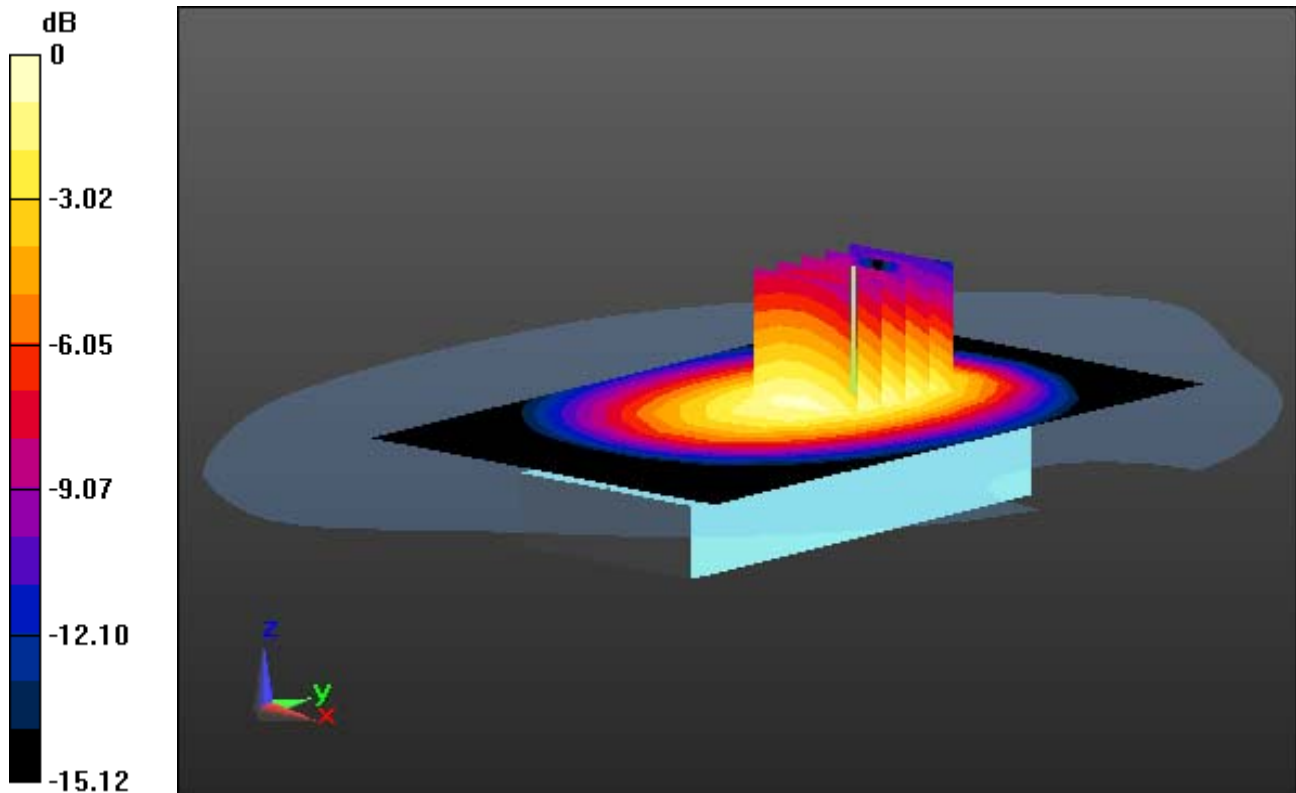

0 dB = 1.07 W/kg

DT&C Co., Ltd.

DUT: DA28; Type: Folder

Communication System: GSM 850_12 (0); Frequency: 848.8 MHz; Duty Cycle: 1:2.075
Medium parameters used: $f = 848.8$ MHz; $\sigma = 1.003$ S/m; $\epsilon_r = 53.398$; $\rho = 1000$ kg/m³
Phantom section: Flat Section

DASY5 Configuration:

Probe: EX3DV4 - SN3866; ConvF(9.21, 9.21, 9.21); Calibrated: 6/29/2016; Electronics: DAE4 Sn1391
Phantom: SAM with CRP_2016_07_22_middle; Type: QD000P40CD; Serial: TP:1786
Measurement SW: DASY52, Version 52.8 (8); SEMCAD X Version 14.6.10 (7331)

Test Date: 2017-03-14; Ambient Temp; 20.9; Tissue Temp: 21.2

1 cm space from Body, Rear, GSM850 GPRS 4Tx Ch. 251, Ant Internal

With Enlarge plot image

Area Scan (8x12x1): Measurement grid: dx=15mm, dy=15mm

Zoom Scan (5x5x7)/Cube 0: Measurement grid: dx=8mm, dy=8mm, dz=5mm

Power Drift = 0.03 dB

Peak SAR (extrapolated) = 1.23 W/kg

SAR(1 g) = 0.886 W/kg; SAR(10 g) = 0.621 W/kg

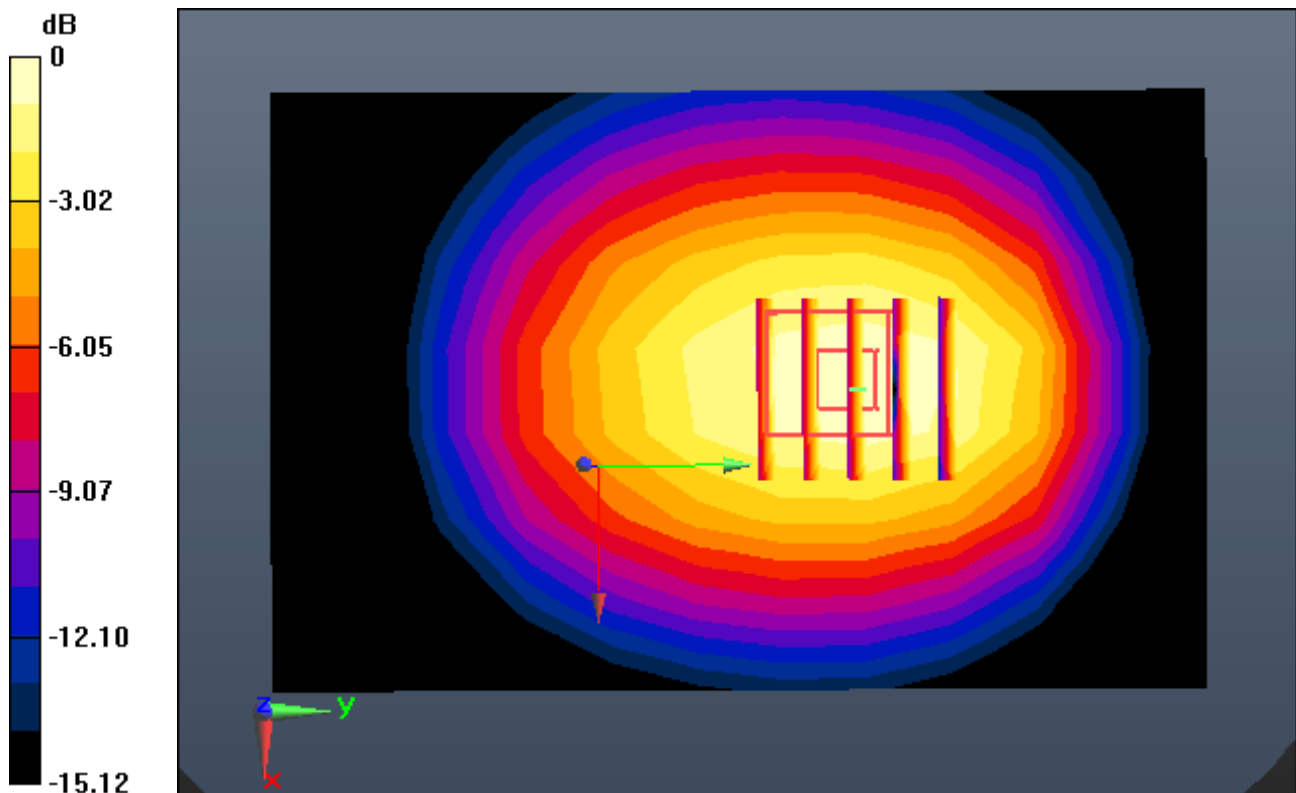

0 dB = 1.07 W/kg

DT&C Co., Ltd.

DUT: DA28; Type: Folder

Communication System: GSM 850_12 (0); Frequency: 848.8 MHz; Duty Cycle: 1:2.075
Medium parameters used: $f = 848.8$ MHz; $\sigma = 1.003$ S/m; $\epsilon_r = 53.398$; $\rho = 1000$ kg/m³
Phantom section: Flat Section

DASY5 Configuration:

Probe: EX3DV4 - SN3866; ConvF(9.21, 9.21, 9.21); Calibrated: 6/29/2016; Electronics: DAE4 Sn1391
Phantom: SAM with CRP_2016_07_22_middle; Type: QD000P40CD; Serial: TP:1786
Measurement SW: DASY52, Version 52.8 (8); SEMCAD X Version 14.6.10 (7331)

Test Date: 2017-03-14; Ambient Temp; 20.9; Tissue Temp: 21.2

1 cm space from Body, Rear, GSM850 GPRS 4Tx Ch. 251, Ant Internal

Area Scan (8x12x1): Measurement grid: dx=15mm, dy=15mm

Zoom Scan (5x5x7)/Cube 0: Measurement grid: dx=8mm, dy=8mm, dz=5mm

Power Drift = 0.03 dB

Peak SAR (extrapolated) = 1.23 W/kg

SAR(1 g) = 0.886 W/kg; SAR(10 g) = 0.621 W/kg

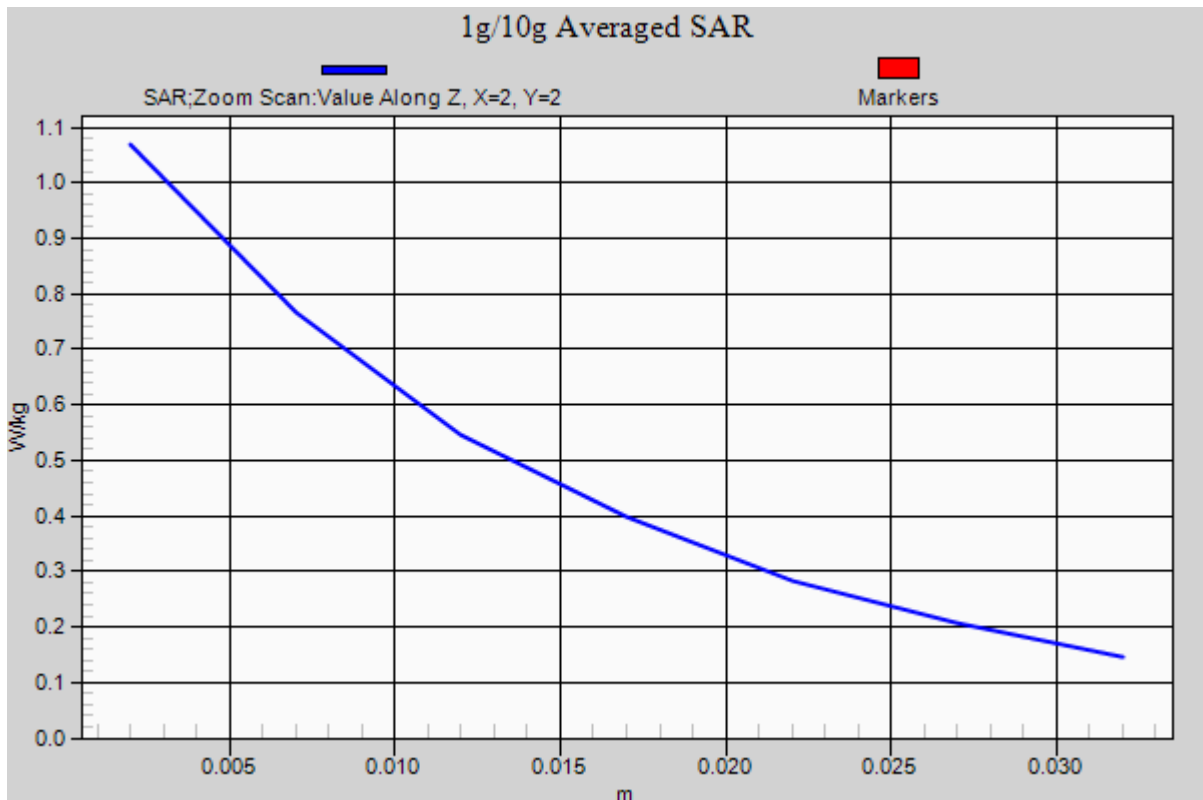

DT&C Co., Ltd.

DUT: DA28; Type: Folder

Communication System: GSM 850_12 (0); Frequency: 848.8 MHz; Duty Cycle: 1:2.075
Medium parameters used: $f = 848.8$ MHz; $\sigma = 1.019$ S/m; $\epsilon_r = 54.177$; $\rho = 1000$ kg/m³
Phantom section: Flat Section

DASY5 Configuration:

Probe: EX3DV4 - SN3866; ConvF(9.21, 9.21, 9.21); Calibrated: 6/29/2016; Electronics: DAE4 Sn1391
Phantom: SAM with CRP_2016_07_22_middle; Type: QD000P40CD; Serial: TP:1786
Measurement SW: DASY52, Version 52.8 (8); SEMCAD X Version 14.6.10 (7331)

Test Date: 2017-03-15; Ambient Temp; 20.8; Tissue Temp: 22.0

1 cm space from Body, Rear, GSM850 GPRS 4Tx Ch. 251, Ant Internal

Area Scan (8x12x1): Measurement grid: dx=15mm, dy=15mm

Zoom Scan (5x5x7)/Cube 0: Measurement grid: dx=8mm, dy=8mm, dz=5mm

Power Drift = 0.05 dB

Peak SAR (extrapolated) = 1.35 W/kg

SAR(1 g) = 0.942 W/kg; SAR(10 g) = 0.627 W/kg

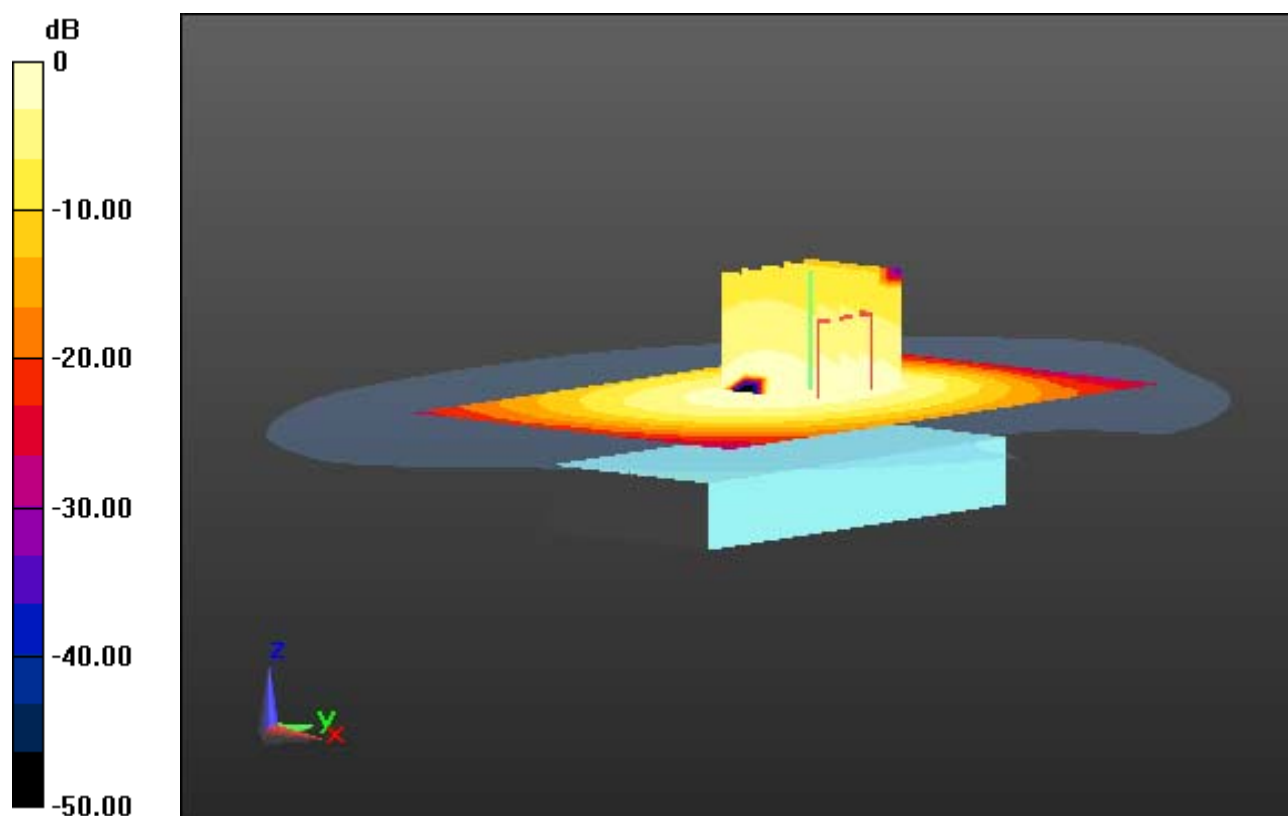

0 dB = 1.08 W/kg

DT&C Co., Ltd.

DUT: DA28; Type: Folder

Communication System: GSM 850_12 (0); Frequency: 848.8 MHz; Duty Cycle: 1:2.075
Medium parameters used: $f = 848.8$ MHz; $\sigma = 1.019$ S/m; $\epsilon_r = 54.177$; $\rho = 1000$ kg/m³
Phantom section: Flat Section

DASY5 Configuration:

Probe: EX3DV4 - SN3866; ConvF(9.21, 9.21, 9.21); Calibrated: 6/29/2016; Electronics: DAE4 Sn1391
Phantom: SAM with CRP_2016_07_22_middle; Type: QD000P40CD; Serial: TP:1786
Measurement SW: DASY52, Version 52.8 (8); SEMCAD X Version 14.6.10 (7331)

Test Date: 2017-03-15; Ambient Temp; 20.8; Tissue Temp: 22.0

1 cm space from Body, Rear, GSM850 GPRS 4Tx Ch. 251, Ant Internal

With Enlarge Plot image

Area Scan (8x12x1): Measurement grid: dx=15mm, dy=15mm

Zoom Scan (5x5x7)/Cube 0: Measurement grid: dx=8mm, dy=8mm, dz=5mm

Power Drift = 0.05 dB

Peak SAR (extrapolated) = 1.35 W/kg

SAR(1 g) = 0.942 W/kg; SAR(10 g) = 0.627 W/kg

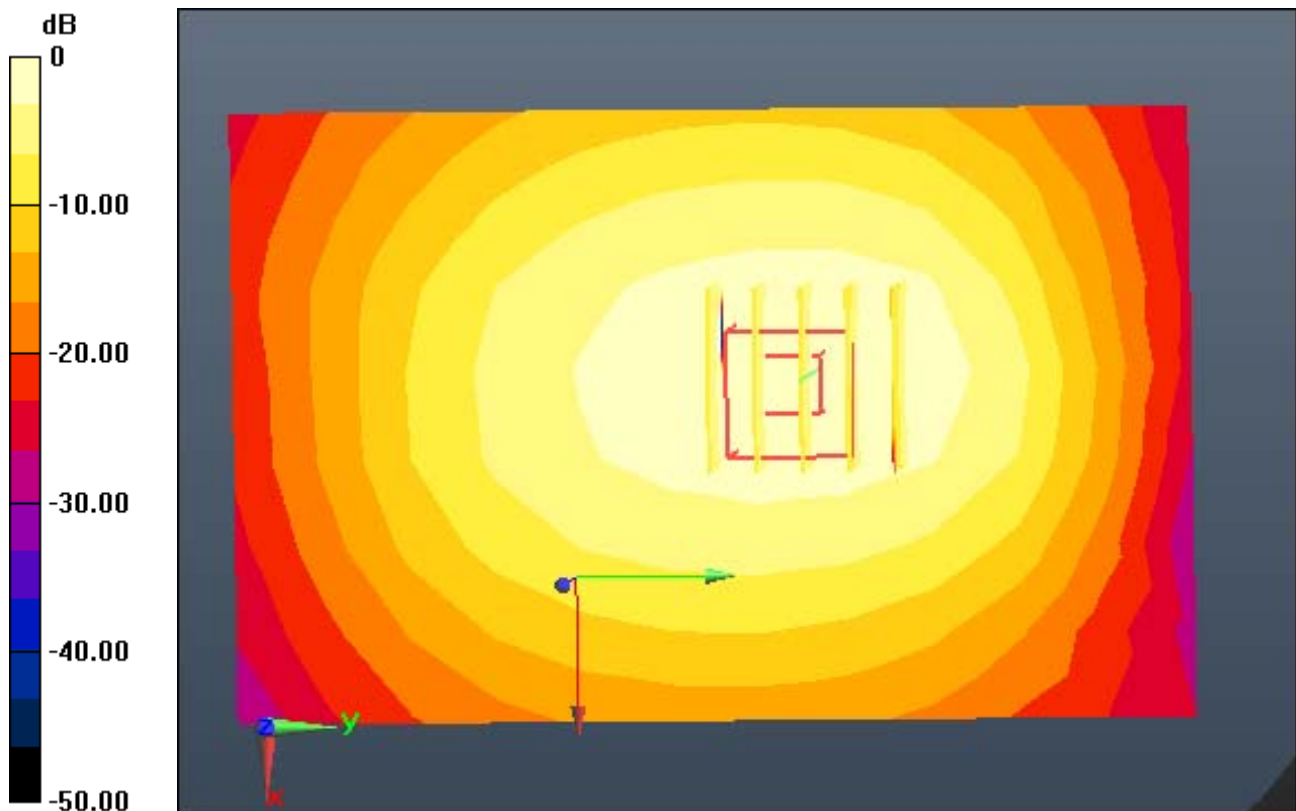

0 dB = 1.08 W/kg

DT&C Co., Ltd.

DUT: DA28; Type: Folder

Communication System: GSM 850_12 (0); Frequency: 848.8 MHz; Duty Cycle: 1:2.075
Medium parameters used: $f = 848.8$ MHz; $\sigma = 1.019$ S/m; $\epsilon_r = 54.177$; $\rho = 1000$ kg/m³
Phantom section: Flat Section

DASY5 Configuration:

Probe: EX3DV4 - SN3866; ConvF(9.21, 9.21, 9.21); Calibrated: 6/29/2016; Electronics: DAE4 Sn1391
Phantom: SAM with CRP_2016_07_22_middle; Type: QD000P40CD; Serial: TP:1786
Measurement SW: DASY52, Version 52.8 (8); SEMCAD X Version 14.6.10 (7331)

Test Date: 2017-03-15; Ambient Temp; 20.8; Tissue Temp: 22.0

1 cm space from Body, Rear, GSM850 GPRS 4Tx Ch. 251, Ant Internal

Area Scan (8x12x1): Measurement grid: dx=15mm, dy=15mm

Zoom Scan (5x5x7)/Cube 0: Measurement grid: dx=8mm, dy=8mm, dz=5mm

Power Drift = 0.05 dB

Peak SAR (extrapolated) = 1.35 W/kg

SAR(1 g) = 0.942 W/kg; SAR(10 g) = 0.627 W/kg

