

# TEST REPORT

## CERTIFICATE OF CONFORMITY

**Standard:** 47 CFR FCC Part 15, Subpart C (Section 15.247)

**Report No.:** RFBDKG-WTW-P23070157-1 R1

**FCC ID:** JNZYR0090

**Product:** Wireless Keyboard

**Brand:** logitech G, G

**Model No.:** YR0090

**Received Date:** 2023/7/12

**Test Date:** 2023/7/14 ~ 2023/7/27

**Issued Date:** 2024/3/12

**Applicant:** Logitech Far East Ltd.

**Address:** #2 Creation Rd. 4, Science-Based Ind. Park Hsinchu Taiwan, R.O.C.

**Issued By:** Bureau Veritas Consumer Products Services (H.K.) Ltd., Taoyuan Branch  
Hsin Chu Laboratory

**Lab Address:** E-2, No.1, Li Hsin 1st Road, Hsinchu Science Park, Hsinchu City 300, Taiwan

**Test Location:** E-2, No.1, Li Hsin 1st Road, Hsinchu Science Park, Hsinchu City 300, Taiwan

**FCC Registration /** 723255 / TW2022

**Designation Number:**

Approved by: \_\_\_\_\_

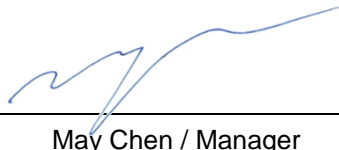

May Chen / Manager

, Date: \_\_\_\_\_

2024/3/12

This test report consists of 54 pages in total. It may be duplicated completely for legal use with the approval of the applicant. It should not be reproduced except in full, without the written approval of our laboratory. The test results in the report only apply to the tested sample. The test results in this report are traceable to the national or international standards.

Prepared by : Claire Kuan / Specialist



This report is governed by, and incorporates by reference, the Conditions of Testing as posted at the date of issuance of this report at <http://www.bureauveritas.com/home/about-us/our-business/cps/about-us/terms-conditions/> and is intended for your exclusive use. Any copying or replication of this report to or for any other person or entity, or use of our name or trademark, is permitted only with our prior written permission. This report sets forth our findings solely with respect to the test samples identified herein. The results set forth in this report are not indicative or representative of the quality or characteristics of the lot from which a test sample was taken or any similar or identical product unless specifically and expressly noted. Our report includes all of the tests requested by you and the results thereof based upon the information that you provided to us. Measurement uncertainty is only provided upon request for accredited tests. Statements of conformity are based on simple acceptance criteria without taking measurement uncertainty into account, unless otherwise requested in writing. You have 60 days from date of issuance of this report to notify us of any material error or omission caused by our negligence or if you require measurement uncertainty; provided, however, that such notice shall be in writing and shall specifically address the issue you wish to raise. A failure to raise such issue within the prescribed time shall constitute your unqualified acceptance of the completeness of this report, the tests conducted and the correctness of the report contents.

## Table of Contents

<b>Release Control Record .....</b>	<b>4</b>
<b>1 Certificate.....</b>	<b>5</b>
<b>2 Summary of Test Results .....</b>	<b>6</b>
2.1 Measurement Uncertainty .....	6
2.2 Supplementary Information .....	6
<b>3 General Information .....</b>	<b>7</b>
3.1 General Description .....	7
3.2 Antenna Description of EUT .....	8
3.3 Channel List.....	9
3.4 Test Mode Applicability and Tested Channel Detail.....	10
3.5 Duty Cycle of Test Signal.....	11
3.6 Test Program Used and Operation Descriptions .....	12
3.7 Connection Diagram of EUT and Peripheral Devices .....	12
3.8 Configuration of Peripheral Devices and Cable Connections .....	12
<b>4 Test Instruments .....</b>	<b>13</b>
4.1 RF Output Power .....	13
4.2 Power Spectral Density .....	13
4.3 6 dB Bandwidth .....	13
4.4 Conducted Out of Band Emissions .....	13
4.5 AC Power Conducted Emissions .....	14
4.6 Unwanted Emissions below 1 GHz .....	15
4.7 Unwanted Emissions above 1 GHz.....	16
<b>5 Limits of Test Items.....</b>	<b>17</b>
5.1 RF Output Power .....	17
5.2 Power Spectral Density .....	17
5.3 6 dB Bandwidth .....	17
5.4 Conducted Out of Band Emissions .....	17
5.5 AC Power Conducted Emissions .....	17
5.6 Unwanted Emissions below 1 GHz .....	17
5.7 Unwanted Emissions above 1 GHz.....	18
<b>6 Test Arrangements.....</b>	<b>19</b>
6.1 RF Output Power.....	19
6.1.1 Test Setup .....	19
6.1.2 Test Procedure.....	19
6.2 Power Spectral Density .....	19
6.2.1 Test Setup .....	19
6.2.2 Test Procedure.....	19
6.3 6 dB Bandwidth .....	20
6.3.1 Test Setup .....	20
6.3.2 Test Procedure.....	20
6.4 Conducted Out of Band Emissions .....	20
6.4.1 Test Setup .....	20
6.4.2 Test Procedure.....	20
6.5 AC Power Conducted Emissions .....	21
6.5.1 Test Setup .....	21
6.5.2 Test Procedure.....	21
6.6 Unwanted Emissions below 1 GHz .....	22
6.6.1 Test Setup .....	22
6.6.2 Test Procedure.....	23
6.7 Unwanted Emissions above 1 GHz.....	24
6.7.1 Test Setup .....	24
6.7.2 Test Procedure.....	24
<b>7 Test Results of Test Item .....</b>	<b>25</b>



7.1	RF Output Power .....	25
7.2	Power Spectral Density .....	26
7.3	6 dB Bandwidth .....	27
7.4	Conducted Out of Band Emissions .....	28
7.5	AC Power Conducted Emissions .....	29
7.6	Unwanted Emissions below 1 GHz .....	33
7.7	Unwanted Emissions above 1 GHz.....	37
<b>8</b>	<b>Pictures of Test Arrangements .....</b>	<b>53</b>
<b>9</b>	<b>Information of the Testing Laboratories .....</b>	<b>54</b>



## Release Control Record

Issue No.	Description	Date Issued
RFBDKG-WTW-P23070157-1	Original release.	2023/8/14
RFBDKG-WTW-P23070157-1 R1	Modified the applicant's address.	2024/3/12

## 1 Certificate

**Product:** Wireless Keyboard

**Brand:** logitech G, G

**Test Model:** YR0090

**Sample Status:** Engineering sample

**Applicant:** Logitech Far East Ltd.

**Test Date:** 2023/7/14 ~ 2023/7/27

**Standard:** 47 CFR FCC Part 15, Subpart C (Section 15.247)

**Measurement** ANSI C63.10-2013

**procedure:** KDB 558074 D01 15.247 Meas Guidance v05r02

The above equipment has been tested by **Bureau Veritas Consumer Products Services (H.K.) Ltd., Taoyuan Branch**, and found compliance with the requirement of the above standards. The test record, data evaluation & Equipment Under Test (EUT) configurations represented herein are true and accurate accounts of the measurements of the sample's RF characteristics under the conditions specified in this report.

## 2 Summary of Test Results

47 CFR FCC Part 15, Subpart C (Section 15.247)			
Standard / Clause	Test Item	Result	Remark
15.247(b)	RF Output Power	Pass	Meet the requirement of limit.
15.247(e)	Power Spectral Density	Pass	Meet the requirement of limit.
15.247(a)(2)	6 dB Bandwidth	Pass	Meet the requirement of limit.
15.247(d)	Conducted Out of Band Emissions	Pass	Meet the requirement of limit.
15.207	AC Power Conducted Emissions	Pass	Minimum passing margin is -7.80 dB at 0.56016 MHz
15.205 / 15.209 / 15.247(d)	Unwanted Emissions below 1 GHz	Pass	Minimum passing margin is -5.0 dB at 42.46 MHz
15.205 / 15.209 / 15.247(d)	Unwanted Emissions above 1 GHz	Pass	Minimum passing margin is -8.6 dB at 2390.00 MHz
15.203	Antenna Requirement	Pass	No antenna connector is used.

Note: Determining compliance based on the results of the compliance measurement, not taking into account measurement instrumentation uncertainty.

### 2.1 Measurement Uncertainty

Where relevant, the following measurement uncertainty levels have been estimated for tests performed on the EUT as specified in CISPR 16-4-2:

Parameter	Specification	Expanded Uncertainty (k=2) (±)
Conducted Out of Band Emissions	9 kHz ~ 40 GHz	2.5 dB
AC Power Conducted Emissions	150 kHz ~ 30 MHz	1.9 dB
Unwanted Emissions below 1 GHz	9 kHz ~ 30 MHz	3.1 dB
	30 MHz ~ 1 GHz	5.1 dB
Unwanted Emissions above 1 GHz	1 GHz ~ 18 GHz	5.1 dB
	18 GHz ~ 40 GHz	5.3 dB

The other instruments specified are routine verified to remain within the calibrated levels, no measurement uncertainty is required to be calculated.

### 2.2 Supplementary Information

There is not any deviation from the test standards for the test method, and no modifications required for compliance.

### 3 General Information

#### 3.1 General Description

Product	Wireless Keyboard
Brand	logitech G, G
Test Model	YR0090
Status of EUT	Engineering sample
Power Supply Rating	3.7 Vdc from battery or 5 Vdc from USB interface
Modulation Type	GFSK
Modulation Technology	DTS
Transfer Rate	2 Mbps
Operating Frequency	2403 ~ 2479 MHz
Number of Channel	77
Output Power	3.776 mW (5.77 dBm)
Accessory	Refer to Note

Note:

1. The EUT may have a lot of colors for marketing requirement.
2. The EUT of LIGHTSPEED and Bluetooth technology can't transmit simultaneously, which uses timely shared coexistence technology.
3. The EUT could be supplied with a rechargeable battery as the following table:

<b>Wireless USB dongle</b>		
Brand	Model	
Logitech	CU0021	
<b>Extender</b>		
Brand	Model	
logitech G, G	502-001365	
<b>USB-A to USB-C cable</b>		
Brand	Model	Specification
logitech G, G	502-001478	shielded with 1 core, 1.8 m
<b>Battery (main source)</b>		
Brand	Model	Specification
Springpower	325085 or 533-000204	Power Rating : 3.7 Vdc, 5.55 Wh, 1500 mAh

4. The EUT may have the 2<sup>nd</sup> source for below components:

Components list	Components Location	Remark
coax. cable	the cable that connects MB and ANT PCB	Same spec, only vendors are different
I-PEX connector	MB	Same spec, only vendors are different
FFC connector	CN1 (MB), CN1 (SWB)	Same spec, only vendors are different
crystal	XT1 (MB)	Same spec, only vendors are different
ESD diode	(MB) D5,D7,D8,D9,D10,D11,D12,D13,D14,D15,D16,D17,D18, D19,D20,D21,D22, Z5, Z6 (SWB) D1,D2,D3,D4,D5,D6,D7,D8,D9,D10,D11,D12,D13,D16, D17,Z5, Z6	Same spec, only vendors are different
charging IC	U2	Same spec, only vendors are different
Power MoS/PCB	Q1, Q2	Same spec, only vendors are different
PCB	-	Same spec, only vendors are different
Battery	-	Brand: SYNERGY Model: AHB355085PCT-03 or 533-000210 Power Rating : 3.7 Vdc, 5.6Wh, 1500mAh

5. The above EUT information is declared by manufacturer and for more detailed features description, please refer to the manufacturer's specifications or User's Manual.

### 3.2 Antenna Description of EUT

1. The antenna information is listed as below.

Antenna Gain (dBi)	Frequency range (GHz)	Antenna Type	Connector Type
2.55	2.4~2.4835	PIFA	none

\* Detail antenna specification please refer to antenna datasheet and/or antenna measurement report.



### 3.3 Channel List

77 channels are provided to this EUT:

Channel	Freq. (MHz)	Channel	Freq. (MHz)	Channel	Freq. (MHz)	Channel	Freq. (MHz)
1	2403	21	2423	41	2443	61	2463
2	2404	22	2424	42	2444	62	2464
3	2405	23	2425	43	2445	63	2465
4	2406	24	2426	44	2446	64	2466
5	2407	25	2427	45	2447	65	2467
6	2408	26	2428	46	2448	66	2468
7	2409	27	2429	47	2449	67	2469
8	2410	28	2430	48	2450	68	2470
9	2411	29	2431	49	2451	69	2471
10	2412	30	2432	50	2452	70	2472
11	2413	31	2433	51	2453	71	2473
12	2414	32	2434	52	2454	72	2474
13	2415	33	2435	53	2455	73	2475
14	2416	34	2436	54	2456	74	2476
15	2417	35	2437	55	2457	75	2477
16	2418	36	2438	56	2458	76	2478
17	2419	37	2439	57	2459	77	2479
18	2420	38	2440	58	2460		
19	2421	39	2441	59	2461		
20	2422	40	2442	60	2462		

### 3.4 Test Mode Applicability and Tested Channel Detail

Pre-Scan:	<p>1. For Unwanted Emission ( below 1GHz ) items: Battery/ AC Adapter. Pre-scan these modes and find the worst case as a representative test condition.</p> <p>2. For AC power conducted emission items: AC Adapter/ Laptop. Only these modes as a representative test condition.</p> <p>3. EUT has the following samples: Main source / 2nd source. Pre-scan these samples of EUT and find the worst case as a representative test condition(except Unwanted emission and AC conduction test items)</p> <p>4. Pre-Scan has been conducted to determine the worst-case mode from all possible combinations between available modulations, data rates and antenna ports (if EUT with antenna diversity architecture).</p>
Worst Case:	<p>1. Unwanted Emission ( below 1GHz ) worst condition:AC Adapter</p> <p>2. AC power conducted emission worst condition:AC Adapter</p> <p>3. The sample of EUT worst condition: Main source</p>

Following channel(s) was (were) selected for the final test as listed below:

Test Item	EUT Configure Mode	Tested Channel	Modulation	Data Rate Parameter
RF Output Power / Power Spectral Density	A	1, 40, 77	GFSK	2Mb/s
6 dB Bandwidth / Conducted Out of Band Emissions	A	1, 40, 77	GFSK	2Mb/s
AC Power Conducted Emissions	A	77	GFSK	2Mb/s
	B	77	GFSK	2Mb/s
Unwanted Emissions below 1 GHz	A	77	GFSK	2Mb/s
	B	77	GFSK	2Mb/s
Unwanted Emissions above 1 GHz	A	1, 40, 77	GFSK	2Mb/s
	B	1, 40, 77	GFSK	2Mb/s
EUT Configure Mode:	A	Main source		
	B	2nd source		

### 3.5 Duty Cycle of Test Signal

#### Mode A

**GFSK:** Duty cycle =  $0.188 \text{ ms} / 0.779 \text{ ms} \times 100\% = 24.1\%$ , duty factor =  $10 * \log (1/\text{Duty cycle}) = 6.17 \text{ dB}$

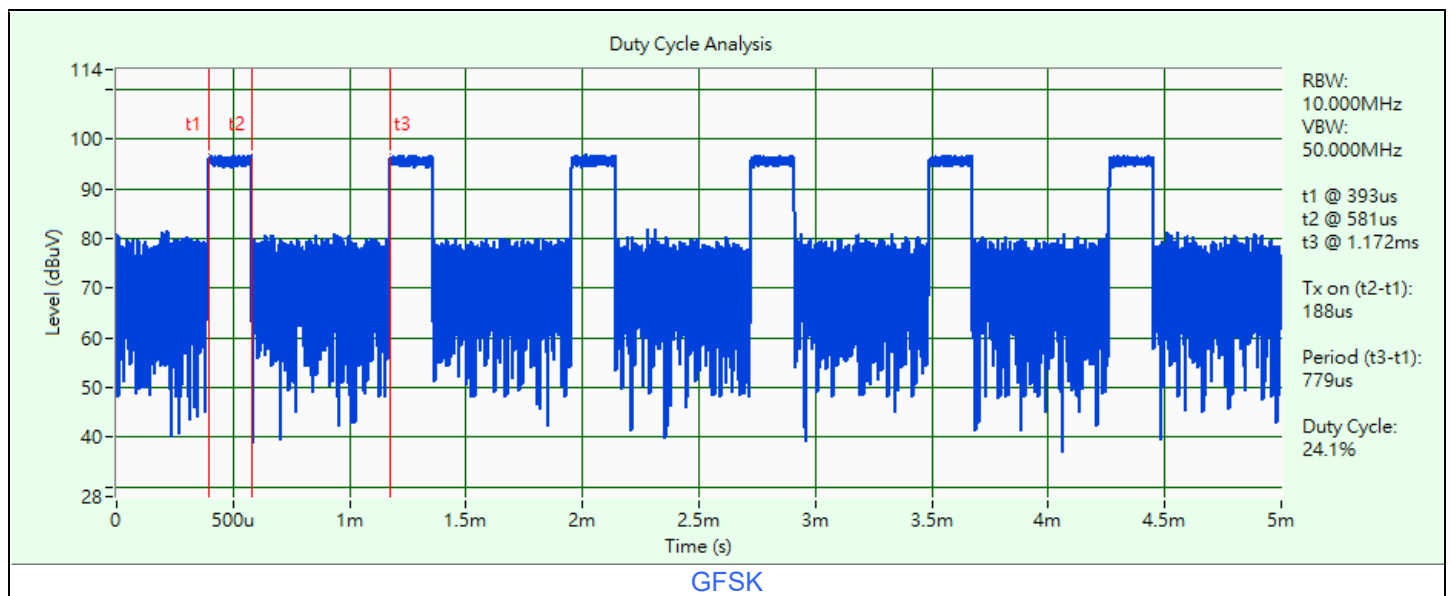

#### Mode B

**GFSK:** Duty cycle =  $0.188 \text{ ms} / 0.782 \text{ ms} \times 100\% = 24\%$ , duty factor =  $10 * \log (1/\text{Duty cycle}) = 6.19 \text{ dB}$

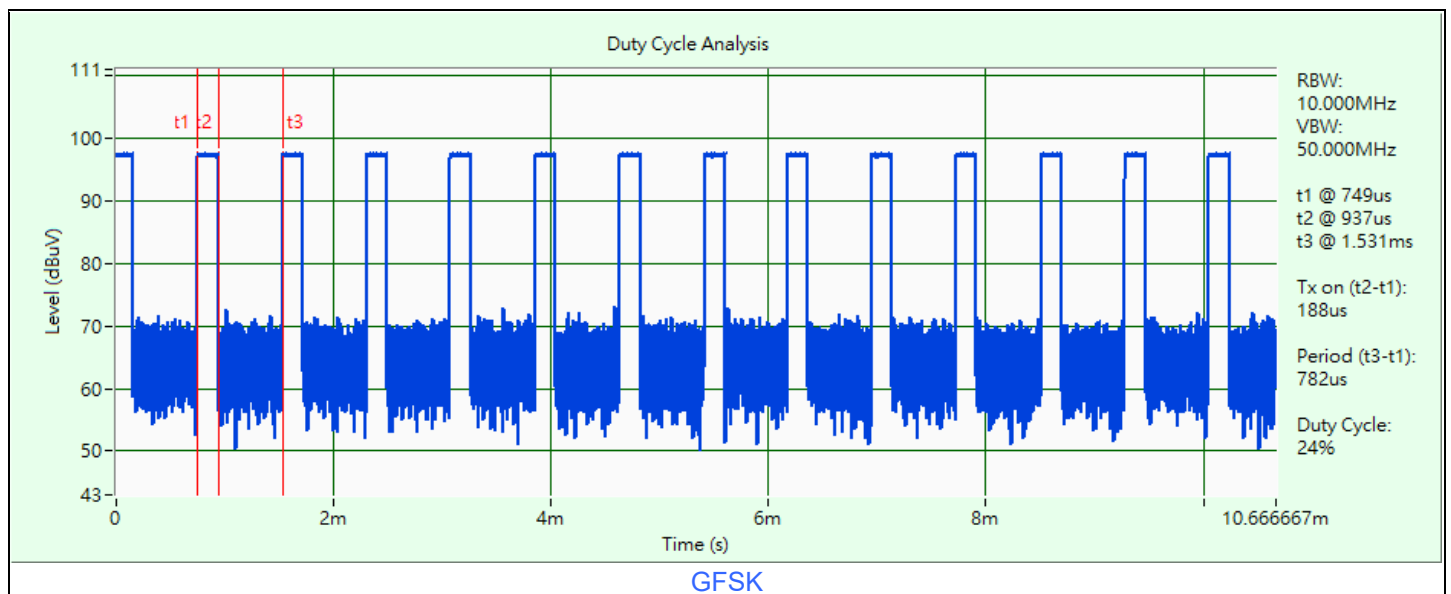

### 3.6 Test Program Used and Operation Descriptions

Controlling software (RF Sample with Receiver [Number Lock]) has been activated to set the EUT under transmission condition continuously at specific channel frequency.

Test Item	Operation Description
RF Output Power / Power Spectral Density / 6 dB Bandwidth / Conducted Out of Band Emissions / Unwanted Emissions above 1 GHz	LS2 TX Modulated 2403MHz LS2 TX Modulated 2442MHz LS2 TX Modulated 2479MHz
AC Power Conducted Emissions / Unwanted Emissions below 1 GHz	LS2 TX Modulated 2479MHz

### 3.7 Connection Diagram of EUT and Peripheral Devices

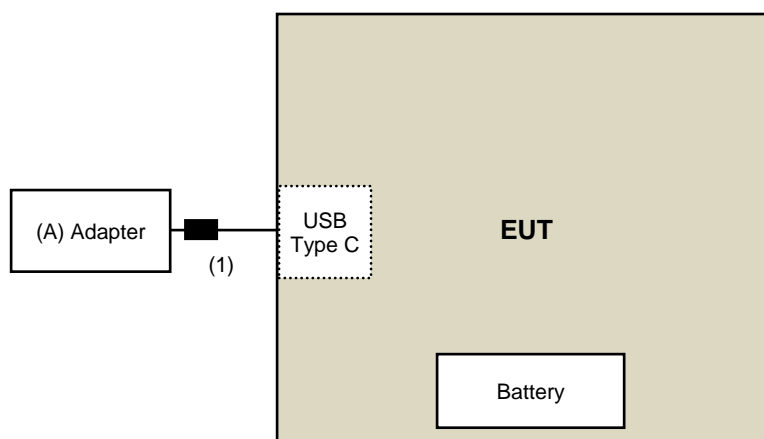

### 3.8 Configuration of Peripheral Devices and Cable Connections

ID	Cable Descriptions	Qty.	Length (m)	Shielding (Yes/No)	Cores (Qty.)	Remarks
1	Type A to C Cable	1	1.8	Yes	1	Supplied by applicant

## 4 Test Instruments

The calibration interval of the all test instruments are 12 months and the calibrations are traceable to NML/ROC and NIST/USA.

### 4.1 RF Output Power

Description Manufacturer	Model No.	Serial No.	Calibrated Date	Calibrated Until
Fixed Attenuator Woken	MDCS18N-10	MDCS18N-10-01	2023/3/27	2024/3/26
Power Meter Anritsu	ML2495A	1529002	2023/6/17	2024/6/16
Pulse Power Sensor Anritsu	MA2411B	1726434	2023/6/19	2024/6/18

Notes:

1. The test was performed in Oven room 2.
2. Tested Date: 2023/7/17

### 4.2 Power Spectral Density

Description Manufacturer	Model No.	Serial No.	Calibrated Date	Calibrated Until
Fixed Attenuator Woken	MDCS18N-10	MDCS18N-10-01	2023/3/27	2024/3/26
MXA Signal Analyzer Keysight	N9020B	MY60112409	2023/2/18	2024/2/17
Software	ADT_RF Test Software V6.6.5.4	N/A	N/A	N/A

Notes:

1. The test was performed in Oven room 2.
2. Tested Date: 2023/7/17

### 4.3 6 dB Bandwidth

Refer to section 4.2 to get information of the instruments.

### 4.4 Conducted Out of Band Emissions

Refer to section 4.2 to get information of the instruments.

#### 4.5 AC Power Conducted Emissions

Description Manufacturer	Model No.	Serial No.	Calibrated Date	Calibrated Until
50 ohm terminal resistance	N/A	EMC-01	2022/9/27	2023/9/26
EMI Test Receiver R&S	ESCS 30	847124/029	2022/10/14	2023/10/13
Fixed Attenuator STI	STI02-2200-10	005	2023/7/1	2024/6/30
LISN R&S	ESH3-Z5	848773/004	2022/10/18	2023/10/17
RF Coaxial Cable JYEBAO	5D-FB	COCCAB-001	2023/7/1	2024/6/30
Software BVADT	BVADT_Cond_V7.3.7.4	N/A	N/A	N/A

Notes:

1. The test was performed in Conduction 1
2. Tested Date: 2023/7/27

#### 4.6 Unwanted Emissions below 1 GHz

Description Manufacturer	Model No.	Serial No.	Calibrated Date	Calibrated Until
Bi_Log Antenna Schwarzbeck	VULB 9168	9168-0842	2022/10/24	2023/10/23
Boresight Antenna Tower & Turn Table Max-Full	MF-7802BS	MF780208530	N/A	N/A
EMI Test Receiver R&S	ESR3	102528	2023/2/10	2024/2/9
Fixed Attenuator Mini-Circuits	UNAT-5+	PAD-ATT5-02	2022/12/28	2023/12/27
Loop Antenna Electro-Metrics	EM-6879	264	2023/2/21	2024/2/20
MXA Signal Analyzer Keysight	N9020B	MY60112410	2023/3/6	2024/3/5
Preamplifier Agilent	8447D	2944A10636	2023/3/12	2024/3/11
Preamplifier EMCI	EMC330N	980538	2023/4/6	2024/4/5
PXA Signal Analyzer Keysight	N9030B	MY57141948	2023/5/19	2024/5/18
RF Coaxial Cable JYEBAO	5D-FB	LOOPCAB-001	2022/12/19	2023/12/18
		LOOPCAB-002	2022/12/19	2023/12/18
RF Coaxial Cable PEWC	8D	966-5-1	2023/4/6	2024/4/5
		966-5-2	2023/4/6	2024/4/5
		966-5-3	2023/4/6	2024/4/5
Software	ADT_Radiated_V8.7.08	N/A	N/A	N/A

Notes:

1. The test was performed in 966 Chamber No. 5.
2. Tested Date: 2023/7/27

#### 4.7 Unwanted Emissions above 1 GHz

Description Manufacturer	Model No.	Serial No.	Calibrated Date	Calibrated Until
Boresight Antenna Tower & Turn Table Max-Full	MF-7802BS	MF780208530	N/A	N/A
EMI Test Receiver R&S	ESR3	102528	2023/2/10	2024/2/9
Horn Antenna Schwarzbeck	BBHA 9120D	9120D-1819	2022/11/13	2023/11/12
	BBHA 9170	9170-739	2022/11/13	2023/11/12
MXA Signal Analyzer Keysight	N9020B	MY60112410	2023/3/6	2024/3/5
Preamplifier EMCI	EMC12630SE	980509	2023/4/7	2024/4/6
	EMC184045SE	980387	2022/12/28	2023/12/27
RF Coaxial Cable EMCI	EMC-KM-KM-4000	200214	2023/2/20	2024/2/19
	EMC102-KM-KM-1200	160924	2022/12/28	2023/12/27
	EMC104-SM-SM-1500	180503	2023/4/7	2024/4/6
	EMC104-SM-SM-2000	180501	2023/4/7	2024/4/6
	EMC104-SM-SM-6000	180506	2023/4/7	2024/4/6
Software	ADT_Radiated_V8.7.08	N/A	N/A	N/A

Notes:

1. The test was performed in 966 Chamber No. 5.
2. Tested Date: 2023/7/14 ~ 2023/7/24



## 5 Limits of Test Items

### 5.1 RF Output Power

For systems using digital modulation in the 2400–2483.5 MHz bands: 1 Watt (30 dBm)

### 5.2 Power Spectral Density

The Maximum of Power Spectral Density Measurement is 8 dBm in any 3 kHz.

### 5.3 6 dB Bandwidth

The minimum of 6 dB Bandwidth Measurement is 0.5 MHz.

### 5.4 Conducted Out of Band Emissions

Below 20 dB of the highest emission level of operating band (in 100 kHz Resolution Bandwidth).

### 5.5 AC Power Conducted Emissions

Frequency (MHz)	Conducted Limit (dBuV)	
	Quasi-peak	Average
0.15 - 0.5	66 - 56	56 - 46
0.50 - 5.0	56	46
5.0 - 30.0	60	50

Notes:

1. The lower limit shall apply at the transition frequencies.
2. The limit decreases in line with the logarithm of the frequency in the range of 0.15 to 0.50 MHz.

### 5.6 Unwanted Emissions below 1 GHz

Radiated emissions up to 1 GHz which fall in the restricted bands must comply with the radiated emission limits specified as below table. Other emissions shall be at least 20 dB below the highest level of the desired power:

Frequencies (MHz)	Field Strength (microvolts/meter)	Measurement Distance (meters)
0.009 ~ 0.490	2400/F(kHz)	300
0.490 ~ 1.705	24000/F(kHz)	30
1.705 ~ 30.0	30	30
30 ~ 88	100	3
88 ~ 216	150	3
216 ~ 960	200	3
Above 960	500	3

Notes:

1. The lower limit shall apply at the transition frequencies.
2. Emission level (dBuV/m) = 20 log Emission level (uV/m).

## 5.7 Unwanted Emissions above 1 GHz

Radiated emissions above 1 GHz which fall in the restricted bands must comply with the radiated emission limits specified as below table. Other emissions shall be at least 20 dB below the highest level of the desired power:

Frequencies (MHz)	Field Strength (microvolts/meter)	Measurement Distance (meters)
Above 960	500	3

### Notes:

1. The lower limit shall apply at the transition frequencies.
2. Emission level (dBuV/m) = 20 log Emission level (uV/m).
3. For frequencies above 1000 MHz, the field strength limits are based on average detector, however, the peak field strength of any emission shall not exceed the maximum permitted average limits, specified above by more than 20 dB under any condition of modulation.

## 6 Test Arrangements

### 6.1 RF Output Power

#### 6.1.1 Test Setup

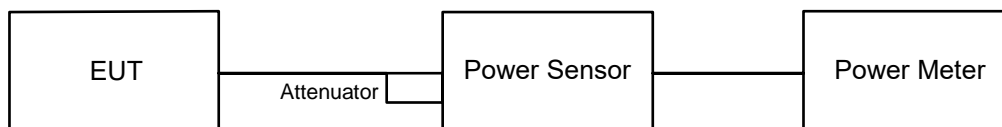

#### 6.1.2 Test Procedure

##### Peak Power:

A peak power sensor was used on the output port of the EUT. A power meter was used to read the response of the peak power sensor. Record the power level.

##### Average Power:

Average power sensor was used to perform output power measurement, trigger and gating function of wide band power meter is enabled to measure max output power of TX on burst. Duty factor is not added to measured value.

### 6.2 Power Spectral Density

#### 6.2.1 Test Setup

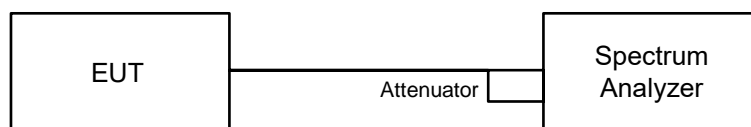

#### 6.2.2 Test Procedure

- a. Set analyzer center frequency to DTS channel center frequency.
- b. Set the span to 1.5 times the DTS bandwidth.
- c. Set the RBW to: 3 kHz.
- d. Set the VBW  $\geq 3 \times$  RBW.
- e. Detector = peak.
- f. Sweep time = auto couple.
- g. Trace mode = max hold.
- h. Allow trace to fully stabilize.
- i. Use the peak marker function to determine the maximum amplitude level within the RBW.

### 6.3 6 dB Bandwidth

#### 6.3.1 Test Setup

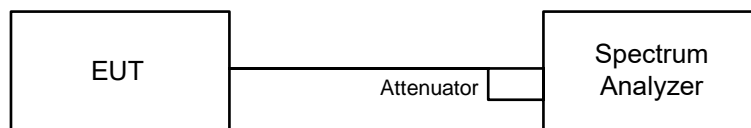

#### 6.3.2 Test Procedure

- a. Set resolution bandwidth (RBW) = 100 kHz.
- b. Set the video bandwidth (VBW)  $\geq 3 \times$  RBW, Detector = Peak.
- c. Trace mode = max hold.
- d. Sweep = auto couple.
- e. Measure the maximum width of the emission that is constrained by the frequencies associated with the two amplitude points (upper and lower) that are attenuated by 6 dB relative to the maximum level measured in the fundamental emission.

### 6.4 Conducted Out of Band Emissions

#### 6.4.1 Test Setup

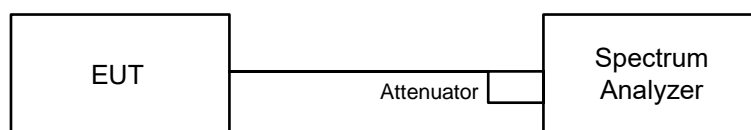

#### 6.4.2 Test Procedure

##### MEASUREMENT PROCEDURE REF

- a. Set the RBW = 100 kHz.
- b. Set the VBW  $\geq 300$  kHz.
- c. Detector = peak.
- d. Sweep time = auto couple.
- e. Trace mode = max hold.
- f. Allow trace to fully stabilize.
- g. Use the peak marker function to determine the maximum power level in any 100 kHz band segment within the fundamental EBW.

##### MEASUREMENT PROCEDURE OOB

- a. Set RBW = 100 kHz.
- b. Set VBW  $\geq 300$  kHz.
- c. Detector = peak.
- d. Sweep = auto couple.
- e. Trace Mode = max hold.
- f. Allow trace to fully stabilize.
- g. Use the peak marker function to determine the maximum amplitude level.

## 6.5 AC Power Conducted Emissions

### 6.5.1 Test Setup

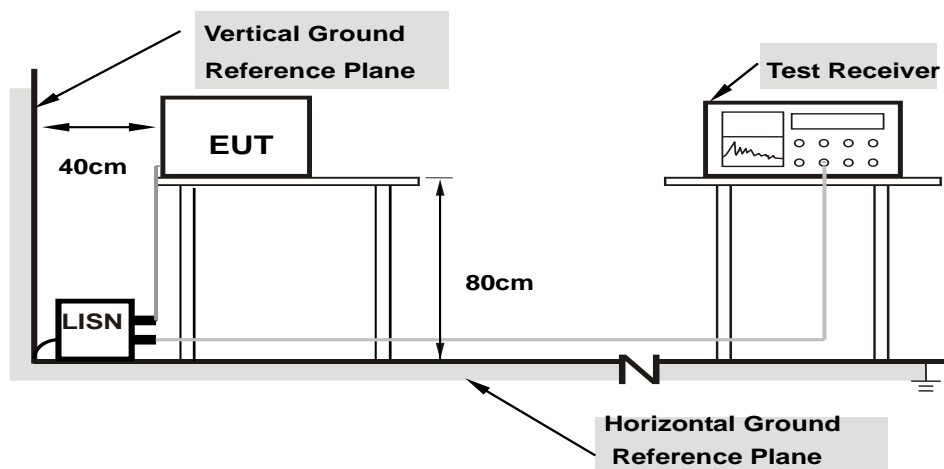

**Note: 1.Support units were connected to second LISN.**

For the actual test configuration, please refer to the attached file (Test Setup Photo).

### 6.5.2 Test Procedure

- The EUT was placed on a 0.8 meter to the top of table and placed 0.4 meters from the conducting wall of the shielded room with EUT being connected to the power mains through a line impedance stabilization network (LISN). Other support units were connected to the power mains through another LISN. The two LISNs provide 50 ohm/ 50 uH of coupling impedance for the measuring instrument.
- Both lines of the power mains connected to the EUT were checked for maximum conducted interference.
- The frequency range from 150 kHz to 30 MHz was searched. Emission levels under (Limit – 20 dB) was not recorded.

Note: The resolution bandwidth and video bandwidth of test receiver is 9 kHz for quasi-peak detection (QP) and average detection (AV) at frequency 0.15 MHz-30 MHz.

## 6.6 Unwanted Emissions below 1 GHz

### 6.6.1 Test Setup

#### For Radiated emission below 30 MHz

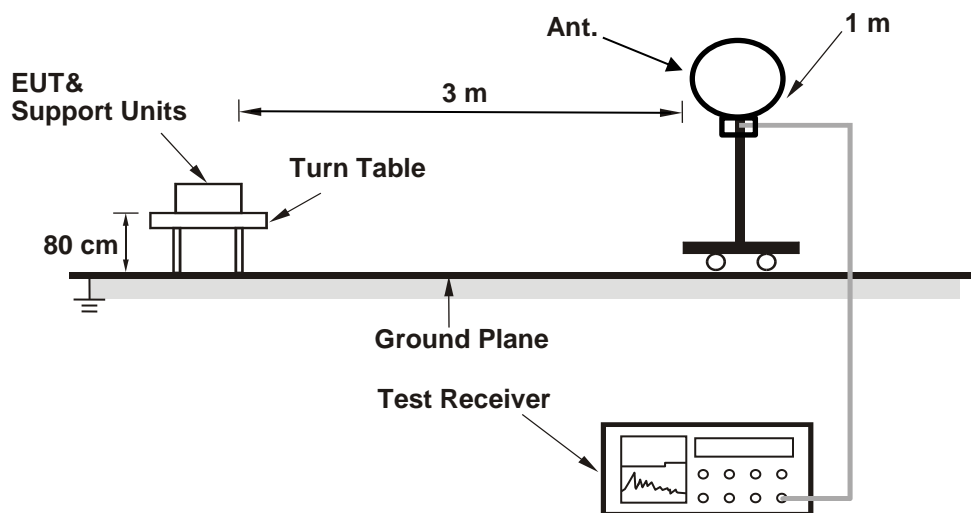

#### For Radiated emission above 30 MHz

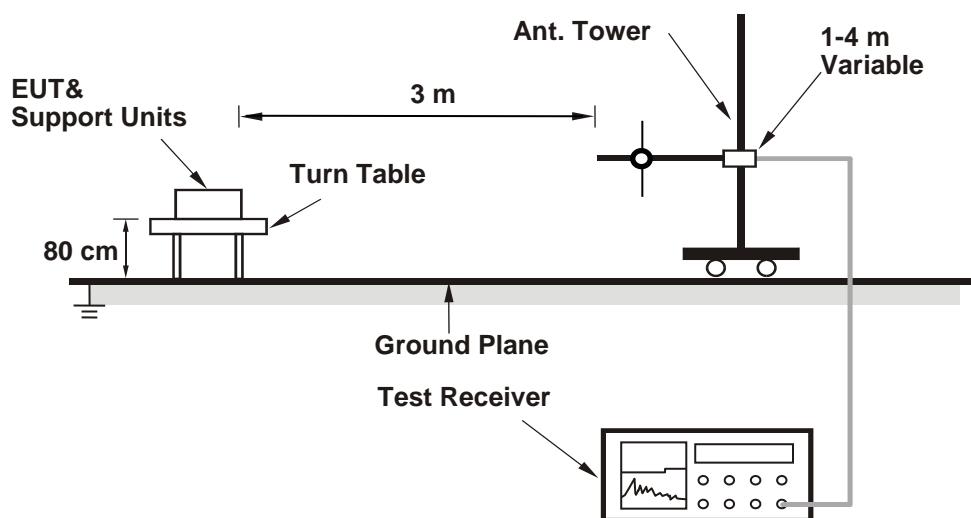

For the actual test configuration, please refer to the attached file (Test Setup Photo).

## 6.6.2 Test Procedure

### For Radiated emission below 30 MHz

- a. The EUT was placed on the top of a rotating table 0.8 meters above the ground at 3 meter chamber room for test. The table was rotated 360 degrees to determine the position of the highest radiation.
- b. The EUT was set 3 meters away from the interference-receiving antenna, which was mounted on the top of a variable-height antenna tower.
- c. Parallel, perpendicular, and ground-parallel orientations of the antenna are set to make the measurement.
- d. For each suspected emission, the EUT was arranged to its worst case and the rotatable table was turned from 0 degrees to 360 degrees to find the maximum reading.
- e. The test-receiver system was set to Quasi-Peak Detect Function and Specified Bandwidth with Maximum Hold Mode, except for the frequency band (9 kHz to 90 kHz and 110 kHz to 490 kHz) set to average detect function and peak detect function.

#### Notes:

1. The resolution bandwidth and video bandwidth of test receiver/spectrum analyzer is 200 Hz at frequency below 150 kHz.
2. The resolution bandwidth and video bandwidth of test receiver/spectrum analyzer is 9 kHz or 10 kHz at frequency (150 kHz to 30 MHz).
3. All modes of operation were investigated and the worst-case emissions are reported.

### For Radiated emission above 30 MHz

- a. The EUT was placed on the top of a rotating table 0.8 meters above the ground at 3 meter chamber room for test. The table was rotated 360 degrees to determine the position of the highest radiation.
- b. The EUT was set 3 meters away from the interference-receiving antenna, which was mounted on the top of a variable-height antenna tower.
- c. The height of antenna is varied from one meter to four meters above the ground to determine the maximum value of the field strength. Both horizontal and vertical polarizations of the antenna are set to make the measurement.
- d. For each suspected emission, the EUT was arranged to its worst case and then the antenna was tuned to heights from 1 meter to 4 meters and the rotatable table was turned from 0 degrees to 360 degrees to find the maximum reading.
- e. The test-receiver system was set to quasi-peak detect function and specified bandwidth with maximum hold mode when the test frequency is below 1 GHz.

#### Notes:

1. The resolution bandwidth and video bandwidth of test receiver/spectrum analyzer is 120 kHz for Quasi-peak detection (QP) at frequency below 1 GHz.
2. All modes of operation were investigated and the worst-case emissions are reported.

## 6.7 Unwanted Emissions above 1 GHz

### 6.7.1 Test Setup

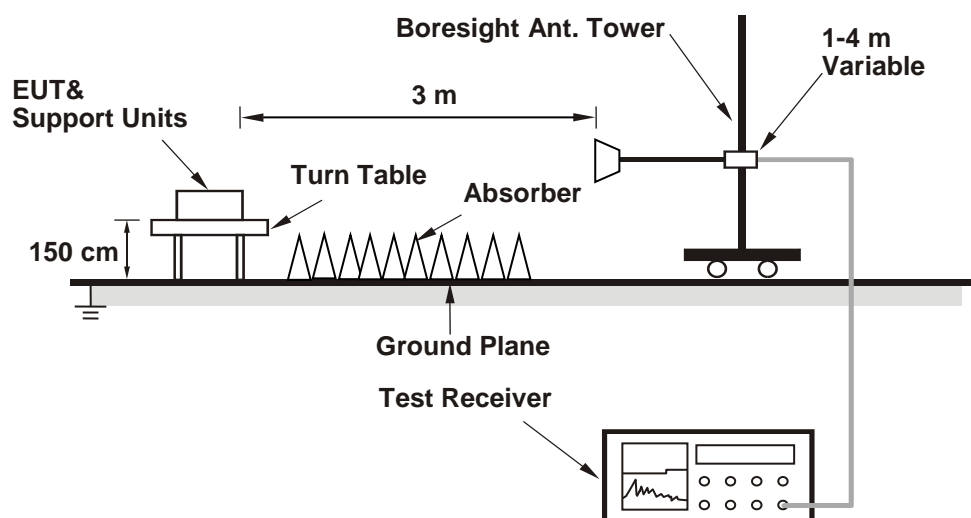

For the actual test configuration, please refer to the attached file (Test Setup Photo).

### 6.7.2 Test Procedure

- The EUT was placed on the top of a rotating table 1.5 meters above the ground at 3 meter chamber room for test. The table was rotated 360 degrees to determine the position of the highest radiation.
- The EUT was set 3 meters away from the interference-receiving antenna, which was mounted on the top of a variable-height antenna tower.
- The height of antenna is varied from one meter to four meters above the ground to determine the maximum value of the field strength. Both horizontal and vertical polarizations of the antenna are set to make the measurement.
- For each suspected emission, the EUT was arranged to its worst case and then the antenna was tuned to heights from 1 meter to 4 meters and the rotatable table was turned from 0 degrees to 360 degrees to find the maximum reading.
- The test-receiver system was set to peak and average detects function and specified bandwidth with maximum hold mode when the test frequency is above 1 GHz. If the peak reading value also meets average limit, measurement with the average detector is unnecessary.

#### Notes:

- The resolution bandwidth of test receiver/spectrum analyzer is 1 MHz and the video bandwidth is 3 MHz for Peak detection (PK) and Average detection (AV) at frequency above 1 GHz.
- According to ANSI C63.10 section 6.6.4 and 4.1.4.2.2. For fundamental and harmonic signal measurement, according to ANSI C63.10 section 7.5, the average value = peak value + duty cycle correction factor. For duty cycle correction factor values, see the Test Signal Duty Cycle section in this report.
- All modes of operation were investigated and the worst-case emissions are reported.



## 7 Test Results of Test Item

### 7.1 RF Output Power

#### Mode A

Input Power:	3.7 Vdc	Environmental Conditions:	25°C, 65% RH	Tested By:	Eric Peng
--------------	---------	---------------------------	--------------	------------	-----------

#### For Peak Power

##### GFSK

Chan.	Chan. Freq. (MHz)	Peak Power (mW)	Peak Power (dBm)	Power Limit (dBm)	Test Result
1	2403	3.228	5.09	30	Pass
40	2442	3.532	5.48	30	Pass
77	2479	3.776	5.77	30	Pass

Note: The antenna gain is 2.55 dBi < 6 dBi, so the output power limit shall not be reduced.

#### For Average Power

##### GFSK

Chan.	Chan. Freq. (MHz)	Average Power (mW)	Average Power (dBm)
1	2403	3.133	4.96
40	2442	3.436	5.36
77	2479	3.664	5.64

## 7.2 Power Spectral Density

### Mode A

Input Power:	3.7 Vdc	Environmental Conditions:	25°C, 65% RH	Tested By:	Eric Peng
--------------	---------	---------------------------	--------------	------------	-----------

### GFSK

Chan.	Chan. Freq. (MHz)	PSD (dBm/3kHz)	PSD Limit (dBm/3kHz)	Test Result
1	2403	-0.42	8	Pass
40	2442	-0.28	8	Pass
77	2479	-0.07	8	Pass

Note: The antenna gain is 2.55 dBi < 6 dBi, so the power density limit shall not be reduced.

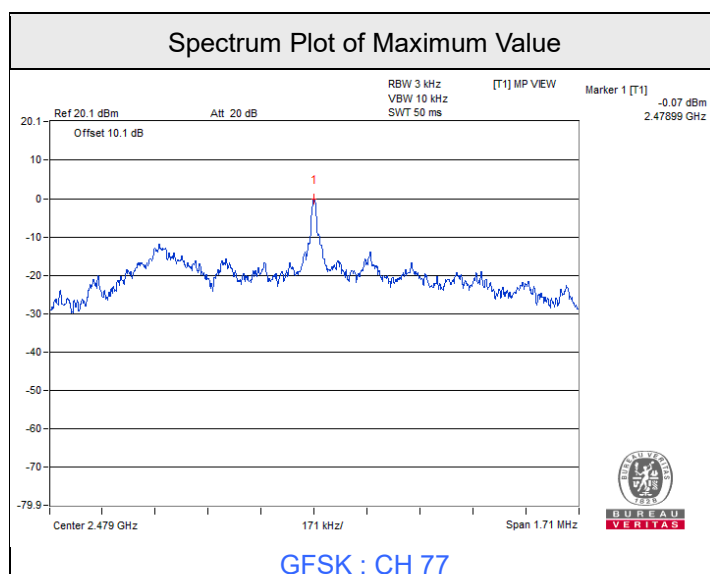

### 7.3 6 dB Bandwidth

#### Mode A

Input Power:	3.7 Vdc	Environmental Conditions:	25°C, 65% RH	Tested By:	Eric Peng
--------------	---------	---------------------------	--------------	------------	-----------

#### GFSK

Channel	Frequency (MHz)	6 dB Bandwidth (MHz)	Minimum Limit (MHz)	Test Result
1	2403	1.14	0.5	Pass
40	2442	1.15	0.5	Pass
77	2479	1.14	0.5	Pass

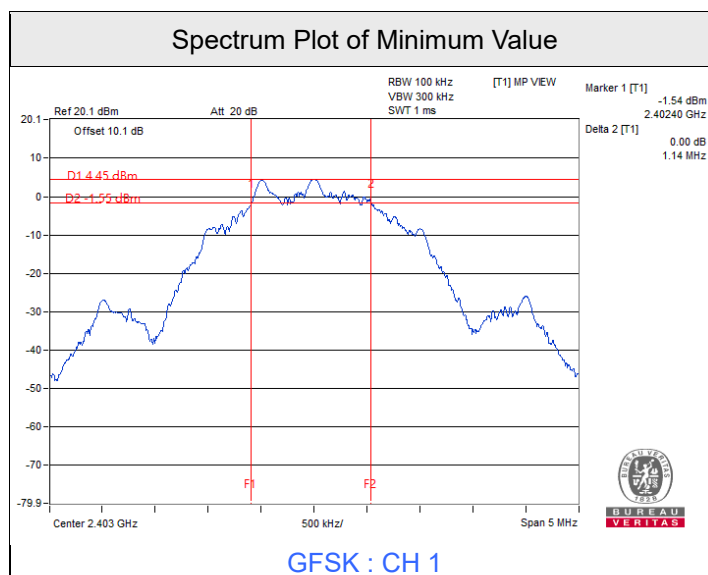



BUREAU VERITAS

### 7.4 Conducted Out of Band Emissions

#### Mode A

Input Power:	3.7 Vdc	Environmental Conditions:	25°C, 65% RH	Tested By:	Eric Peng
--------------	---------	---------------------------	--------------	------------	-----------

#### GFSK

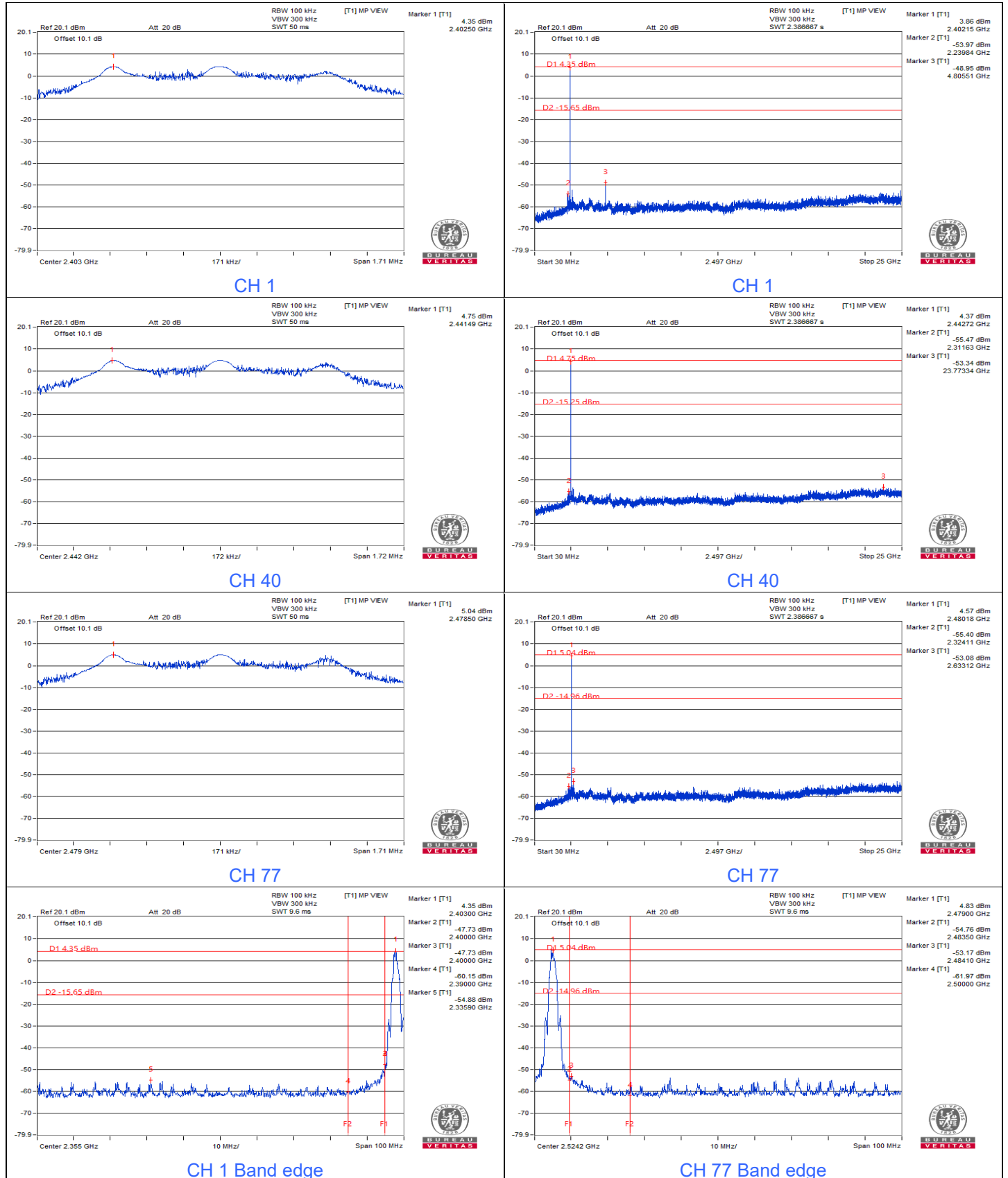

## 7.5 AC Power Conducted Emissions

### Mode A

<b>RF Mode</b>	GFSK	<b>Channel</b>	CH 77 : 2479 MHz
<b>Frequency Range</b>	150kHz ~ 30MHz	<b>Detector Function &amp; Resolution Bandwidth</b>	Quasi-Peak (QP) / Average (AV), 9 kHz
<b>Input Power (System)</b>	120 Vac, 60 Hz	<b>Environmental Conditions</b>	20°C, 72% RH
<b>Tested By</b>	Sampson Chen		

Phase Of Power : Line (L)										
No	Frequency (MHz)	Correction Factor (dB)	Reading Value (dBuV)		Emission Level (dBuV)		Limit (dBuV)		Margin (dB)	
			Q.P.	AV.	Q.P.	AV.	Q.P.	AV.	Q.P.	AV.
1	0.16953	9.95	38.88	26.00	48.83	35.95	64.98	54.98	-16.15	-19.03
2	0.21250	9.95	35.51	24.19	45.46	34.14	63.11	53.11	-17.65	-18.97
3	0.25547	9.95	32.74	22.31	42.69	32.26	61.58	51.58	-18.89	-19.32
4	0.55625	9.97	27.65	20.61	37.62	30.58	56.00	46.00	-18.38	-15.42
5	0.93125	10.00	20.57	10.22	30.57	20.22	56.00	46.00	-25.43	-25.78
6	1.82813	10.03	18.64	8.92	28.67	18.95	56.00	46.00	-27.33	-27.05

#### Remarks:

1. Q.P. and AV. are abbreviations of quasi-peak and average individually.
2. The emission levels of other frequencies were very low against the limit.
3. Margin value = Emission level – Limit value
4. Correction factor = Insertion loss + Cable loss
5. Emission Level = Correction Factor + Reading Value

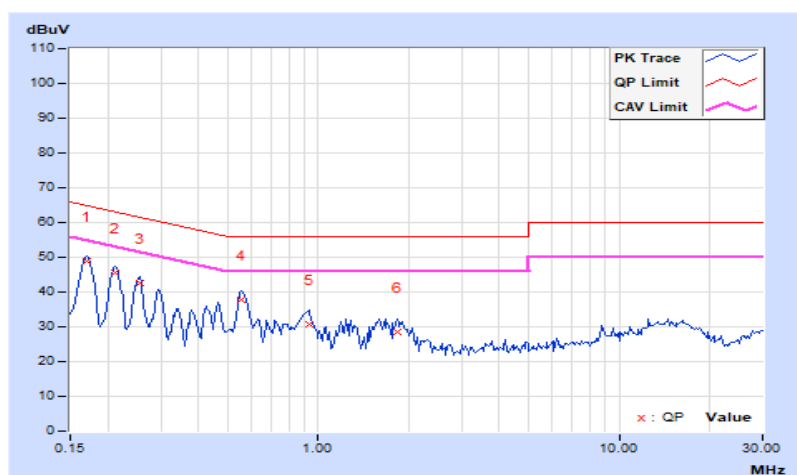

RF Mode	GFSK	Channel	CH 77 : 2479 MHz
Frequency Range	150kHz ~ 30MHz	Detector Function & Resolution Bandwidth	Quasi-Peak (QP) / Average (AV), 9 kHz
Input Power (System)	120 Vac, 60 Hz	Environmental Conditions	20°C, 72% RH
Tested By	Sampson Chen		

Phase Of Power : Neutral (N)										
No	Frequency (MHz)	Correction Factor (dB)	Reading Value (dBuV)		Emission Level (dBuV)		Limit (dBuV)		Margin (dB)	
			Q.P.	AV.	Q.P.	AV.	Q.P.	AV.	Q.P.	AV.
1	0.16953	10.00	37.52	31.21	47.52	41.21	64.98	54.98	-17.46	-13.77
2	0.21250	10.00	33.83	28.92	43.83	38.92	63.11	53.11	-19.28	-14.19
3	0.25547	10.00	31.48	25.65	41.48	35.65	61.58	51.58	-20.10	-15.93
4	0.47031	10.01	30.48	22.94	40.49	32.95	56.51	46.51	-16.02	-13.56
<b>5</b>	<b>0.56016</b>	<b>10.02</b>	<b>34.90</b>	<b>28.18</b>	<b>44.92</b>	<b>38.20</b>	<b>56.00</b>	<b>46.00</b>	<b>-11.08</b>	<b>-7.80</b>
6	0.91563	10.04	24.32	16.46	34.36	26.50	56.00	46.00	-21.64	-19.50

**Remarks:**

1. Q.P. and AV. are abbreviations of quasi-peak and average individually.
2. The emission levels of other frequencies were very low against the limit.
3. Margin value = Emission level – Limit value
4. Correction factor = Insertion loss + Cable loss
5. Emission Level = Correction Factor + Reading Value

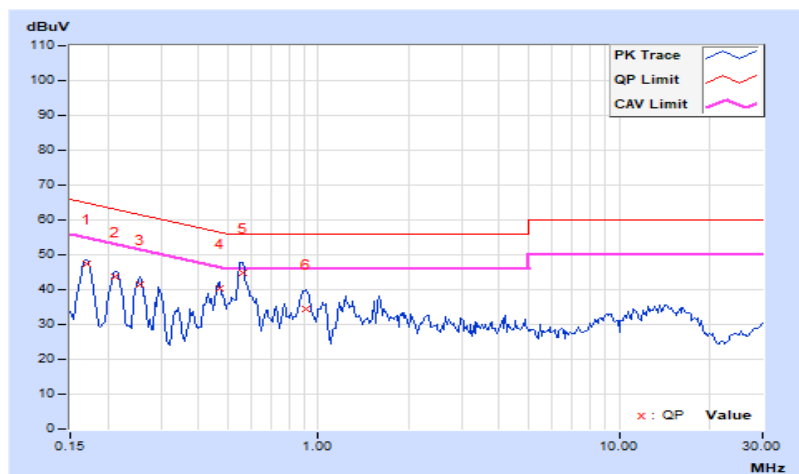

## Mode B

RF Mode	GFSK	Channel	CH 77 : 2479 MHz
Frequency Range	150kHz ~ 30MHz	Detector Function & Resolution Bandwidth	Quasi-Peak (QP) / Average (AV), 9 kHz
Input Power (System)	120 Vac, 60 Hz	Environmental Conditions	20°C, 72% RH
Tested By	Sampson Chen		

Phase Of Power : Line (L)										
No	Frequency (MHz)	Correction Factor (dB)	Reading Value (dBuV)		Emission Level (dBuV)		Limit (dBuV)		Margin (dB)	
			Q.P.	AV.	Q.P.	AV.	Q.P.	AV.	Q.P.	AV.
1	0.16562	9.95	38.42	25.52	48.37	35.47	65.18	55.18	-16.81	-19.71
2	0.20859	9.95	34.29	23.23	44.24	33.18	63.26	53.26	-19.02	-20.08
3	0.24766	9.95	32.68	23.02	42.63	32.97	61.84	51.84	-19.21	-18.87
4	0.28672	9.95	28.50	18.26	38.45	28.21	60.62	50.62	-22.17	-22.41
5	0.55234	9.97	22.56	14.41	32.53	24.38	56.00	46.00	-23.47	-21.62
6	0.90391	9.99	21.57	11.33	31.56	21.32	56.00	46.00	-24.44	-24.68

### Remarks:

1. Q.P. and AV. are abbreviations of quasi-peak and average individually.
2. The emission levels of other frequencies were very low against the limit.
3. Margin value = Emission level – Limit value
4. Correction factor = Insertion loss + Cable loss
5. Emission Level = Correction Factor + Reading Value

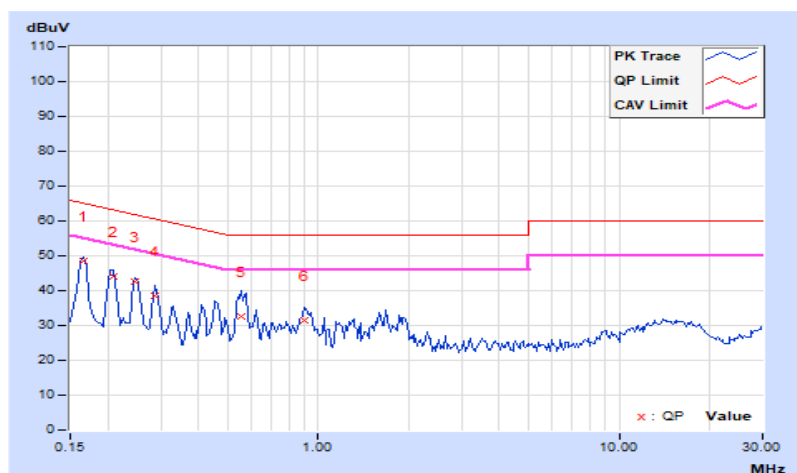

RF Mode	GFSK	Channel	CH 77 : 2479 MHz
Frequency Range	150kHz ~ 30MHz	Detector Function & Resolution Bandwidth	Quasi-Peak (QP) / Average (AV), 9 kHz
Input Power (System)	120 Vac, 60 Hz	Environmental Conditions	20°C, 72% RH
Tested By	Sampson Chen		

Phase Of Power : Neutral (N)										
No	Frequency (MHz)	Correction Factor (dB)	Reading Value (dBuV)		Emission Level (dBuV)		Limit (dBuV)		Margin (dB)	
			Q.P.	AV.	Q.P.	AV.	Q.P.	AV.	Q.P.	AV.
1	0.16562	10.00	37.90	31.51	47.90	41.51	65.18	55.18	-17.28	-13.67
2	0.20859	10.00	33.57	28.50	43.57	38.50	63.26	53.26	-19.69	-14.76
3	0.25156	10.00	31.72	24.69	41.72	34.69	61.71	51.71	-19.99	-17.02
4	0.54063	10.02	34.12	26.47	44.14	36.49	56.00	46.00	-11.86	-9.51
5	0.91172	10.04	28.08	19.45	38.12	29.49	56.00	46.00	-17.88	-16.51
6	14.25391	10.82	20.45	13.05	31.27	23.87	60.00	50.00	-28.73	-26.13

**Remarks:**

1. Q.P. and AV. are abbreviations of quasi-peak and average individually.
2. The emission levels of other frequencies were very low against the limit.
3. Margin value = Emission level – Limit value
4. Correction factor = Insertion loss + Cable loss
5. Emission Level = Correction Factor + Reading Value

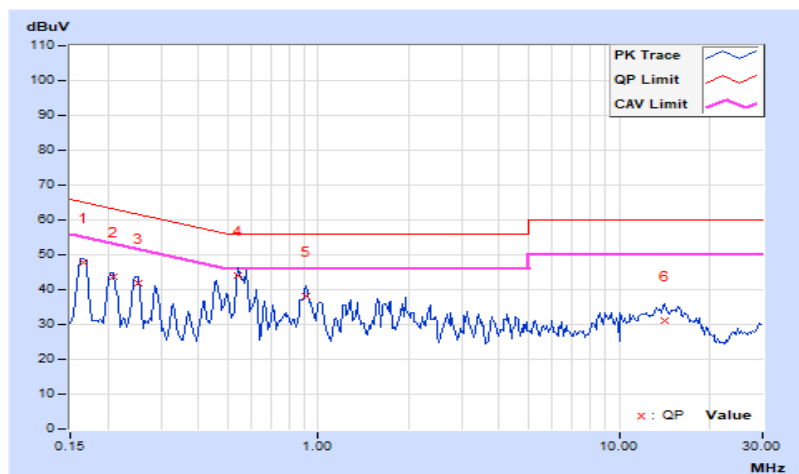



## 7.6 Unwanted Emissions below 1 GHz

### Mode A

RF Mode	GFSK	Channel	CH 77 : 2479 MHz
Frequency Range	30 MHz ~ 1 GHz	Detector Function & Bandwidth	Quasi-Peak (QP), RB = 120kHz
Input Power (System)	120 Vac, 60 Hz	Environmental Conditions	29°C, 74% RH
Tested By	Loius Yang		

Antenna Polarity & Test Distance : Horizontal at 3 m								
No	Frequency (MHz)	Emission Level (dBuV/m)	Limit (dBuV/m)	Margin (dB)	Antenna Height (m)	Table Angle (Degree)	Raw Value (dBuV)	Correction Factor (dB/m)
1	42.13	23.1 QP	40.0	-16.9	1.00 H	237	36.2	-13.1
2	96.76	24.1 QP	43.5	-19.4	2.00 H	97	42.0	-17.9
3	175.90	21.1 QP	43.5	-22.4	1.50 H	100	34.8	-13.7
4	242.46	18.0 QP	46.0	-28.0	1.00 H	94	32.2	-14.2
5	325.90	21.5 QP	46.0	-24.5	1.50 H	135	32.8	-11.3
6	489.43	21.0 QP	46.0	-25.0	1.50 H	30	28.3	-7.3

#### Remarks:

1. Emission Level(dBuV/m) = Raw Value(dBuV) + Correction Factor(dB/m)
2. Correction Factor(dB/m) = Antenna Factor(dB/m) + Cable Factor(dB) – Pre-Amplifier Factor(dB)
3. Margin value = Emission Level – Limit value
4. The other emission levels were very low against the limit of frequency range 30 MHz ~ 1 GHz.
5. The frequency range 9 kHz ~ 30 MHz: all emissions are more than 20 dB below the limit, therefore do not be recorded in this report.

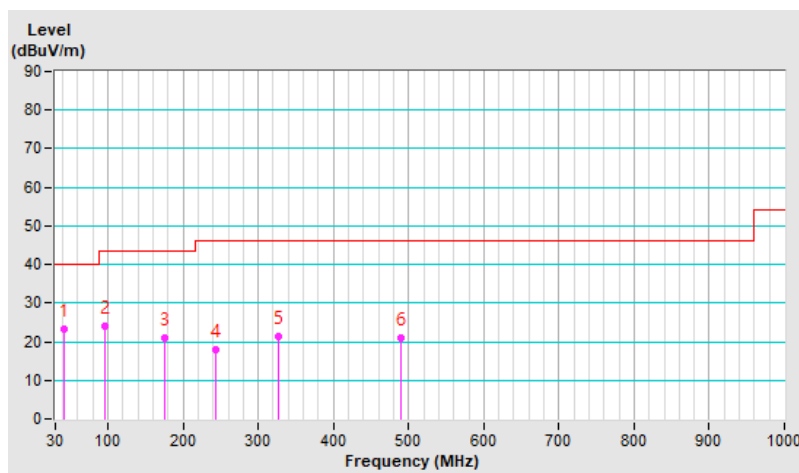

<b>RF Mode</b>	GFSK	<b>Channel</b>	CH 77 : 2479 MHz
<b>Frequency Range</b>	30 MHz ~ 1 GHz	<b>Detector Function &amp; Bandwidth</b>	Quasi-Peak (QP), RB = 120kHz
<b>Input Power (System)</b>	120 Vac, 60 Hz	<b>Environmental Conditions</b>	29°C, 74% RH
<b>Tested By</b>	Loius Yang		

Antenna Polarity & Test Distance : Vertical at 3 m								
No	Frequency (MHz)	Emission Level (dBuV/m)	Limit (dBuV/m)	Margin (dB)	Antenna Height (m)	Table Angle (Degree)	Raw Value (dBuV)	Correction Factor (dB/m)
1	42.46	35.0 QP	40.0	-5.0	1.00 V	60	48.0	-13.0
2	96.55	22.1 QP	43.5	-21.4	1.50 V	10	40.1	-18.0
3	175.31	21.2 QP	43.5	-22.3	1.50 V	347	34.9	-13.7
4	241.71	20.1 QP	46.0	-25.9	1.00 V	5	34.3	-14.2
5	323.00	22.0 QP	46.0	-24.0	1.50 V	80	33.4	-11.4
6	424.28	30.5 QP	46.0	-15.5	2.00 V	188	39.3	-8.8

**Remarks:**

1. Emission Level(dBuV/m) = Raw Value(dBuV) + Correction Factor(dB/m)
2. Correction Factor(dB/m) = Antenna Factor(dB/m) + Cable Factor(dB) – Pre-Amplifier Factor(dB)
3. Margin value = Emission Level – Limit value
4. The other emission levels were very low against the limit of frequency range 30 MHz ~ 1 GHz.
5. The frequency range 9 kHz ~ 30 MHz: all emissions are more than 20 dB below the limit, therefore do not be recorded in this report.

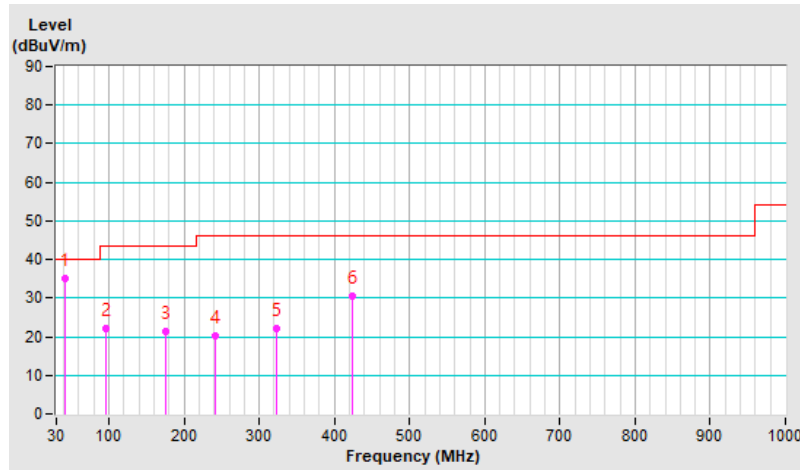

## Mode B

<b>RF Mode</b>	GFSK	<b>Channel</b>	CH 77 : 2479 MHz
<b>Frequency Range</b>	30 MHz ~ 1 GHz	<b>Detector Function &amp; Bandwidth</b>	Quasi-Peak (QP), RB = 120kHz
<b>Input Power (System)</b>	120 Vac, 60 Hz	<b>Environmental Conditions</b>	29°C, 74% RH
<b>Tested By</b>	Loius Yang		

### Antenna Polarity & Test Distance : Horizontal at 3 m

No	Frequency (MHz)	Emission Level (dBuV/m)	Limit (dBuV/m)	Margin (dB)	Antenna Height (m)	Table Angle (Degree)	Raw Value (dBuV)	Correction Factor (dB/m)
1	43.45	22.4 QP	40.0	-17.6	1.50 H	256	35.4	-13.0
2	95.72	24.8 QP	43.5	-18.7	1.50 H	95	43.0	-18.2
3	197.44	15.2 QP	43.5	-28.3	1.50 H	96	31.1	-15.9
4	322.45	21.7 QP	46.0	-24.3	1.50 H	155	33.1	-11.4
5	474.00	22.2 QP	46.0	-23.8	1.50 H	56	29.8	-7.6
6	609.38	25.9 QP	46.0	-20.1	3.00 H	131	30.5	-4.6

### Remarks:

1. Emission Level(dBuV/m) = Raw Value(dBuV) + Correction Factor(dB/m)
2. Correction Factor(dB/m) = Antenna Factor(dB/m) + Cable Factor(dB) – Pre-Amplifier Factor(dB)
3. Margin value = Emission Level – Limit value
4. The other emission levels were very low against the limit of frequency range 30 MHz ~ 1 GHz.
5. The frequency range 9 kHz ~ 30 MHz: all emissions are more than 20 dB below the limit, therefore do not be recorded in this report.

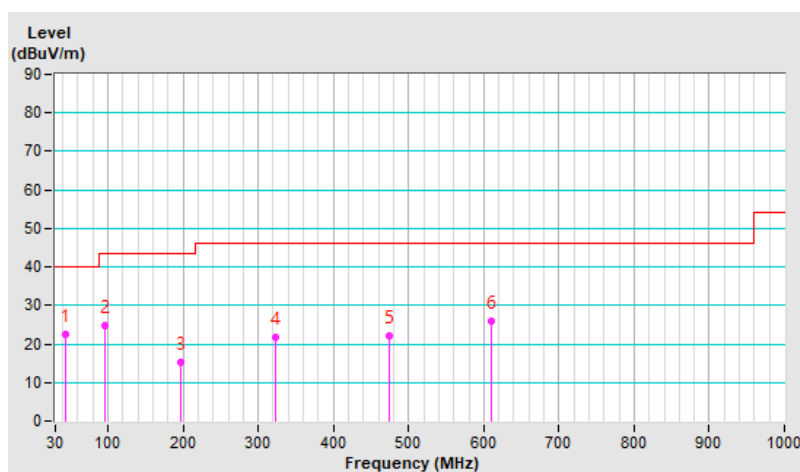

<b>RF Mode</b>	GFSK	<b>Channel</b>	CH 77 : 2479 MHz
<b>Frequency Range</b>	30 MHz ~ 1 GHz	<b>Detector Function &amp; Bandwidth</b>	Quasi-Peak (QP), RB = 120kHz
<b>Input Power (System)</b>	120 Vac, 60 Hz	<b>Environmental Conditions</b>	29°C, 74% RH
<b>Tested By</b>	Loius Yang		

Antenna Polarity & Test Distance : Vertical at 3 m								
No	Frequency (MHz)	Emission Level (dBuV/m)	Limit (dBuV/m)	Margin (dB)	Antenna Height (m)	Table Angle (Degree)	Raw Value (dBuV)	Correction Factor (dB/m)
1	40.83	33.8 QP	40.0	-6.2	2.00 V	312	46.8	-13.0
2	92.23	21.9 QP	43.5	-21.6	1.50 V	344	40.3	-18.4
3	177.41	21.2 QP	43.5	-22.3	1.50 V	356	35.2	-14.0
4	245.21	18.2 QP	46.0	-27.8	1.50 V	20	32.3	-14.1
5	324.34	21.5 QP	46.0	-24.5	1.50 V	60	32.9	-11.4
6	422.10	30.8 QP	46.0	-15.2	2.00 V	197	39.7	-8.9

**Remarks:**

1. Emission Level(dBuV/m) = Raw Value(dBuV) + Correction Factor(dB/m)
2. Correction Factor(dB/m) = Antenna Factor(dB/m) + Cable Factor(dB) – Pre-Amplifier Factor(dB)
3. Margin value = Emission Level – Limit value
4. The other emission levels were very low against the limit of frequency range 30 MHz ~ 1 GHz.
5. The frequency range 9 kHz ~ 30 MHz: all emissions are more than 20 dB below the limit, therefore do not be recorded in this report.

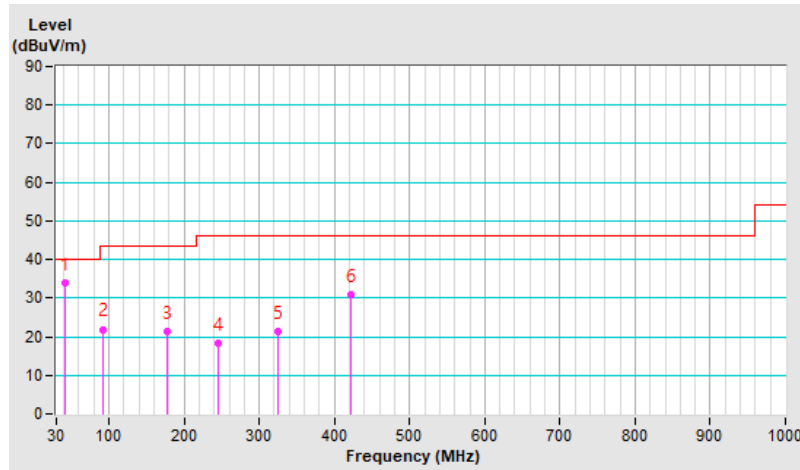

## 7.7 Unwanted Emissions above 1 GHz

### Mode A

RF Mode	GFSK	Channel	CH 1 : 2403 MHz
Frequency Range	1 GHz ~ 25 GHz	Detector Function & Bandwidth	Peak (PK), RB = 1 MHz, VB = 3 MHz RMS (AV), RB = 1 MHz, VB = 3 MHz
Input Power (System)	120 Vac, 60 Hz	Environmental Conditions	28°C, 75% RH
Tested By	Louis Yang		

#### Antenna Polarity & Test Distance : Horizontal at 3 m

No	Frequency (MHz)	Emission Level (dBuV/m)	Limit (dBuV/m)	Margin (dB)	Antenna Height (m)	Table Angle (Degree)	Raw Value (dBuV)	Correction Factor (dB/m)
1	2390.00	54.5 PK	74.0	-19.5	1.00 H	84	57.2	-2.7
2	2390.00	45.0 AV	54.0	-9.0	1.00 H	84	47.7	-2.7
3	*2403.00	98.8 PK			1.00 H	84	101.5	-2.7
4	*2403.00	86.5 AV			1.00 H	84	89.2	-2.7
5	4806.00	37.7 PK	74.0	-36.3	1.03 H	323	36.2	1.5
6	4806.00	25.4 AV	54.0	-28.6	1.03 H	323	23.9	1.5

#### Remarks:

- Emission Level(dBuV/m) = Raw Value(dBuV) + Correction Factor(dB/m)
- Correction Factor(dB/m) = Antenna Factor(dB/m) + Cable Factor(dB) – Pre-Amplifier Factor(dB)
- Margin value = Emission Level – Limit value
- The other emission levels were very low against the limit.
- " \* " : Fundamental frequency, the limit was restricted at the RF Output Power.
- The average value of fundamental and harmonic frequency is: Average = Peak value + 20 log(Duty cycle) Where the duty cycle correction factor is calculated from following formula:  
 $20 \log(\text{Duty cycle}) = 20 \log(0.188 \text{ ms} / 0.779 \text{ ms}) = -12.3 \text{ dB}$

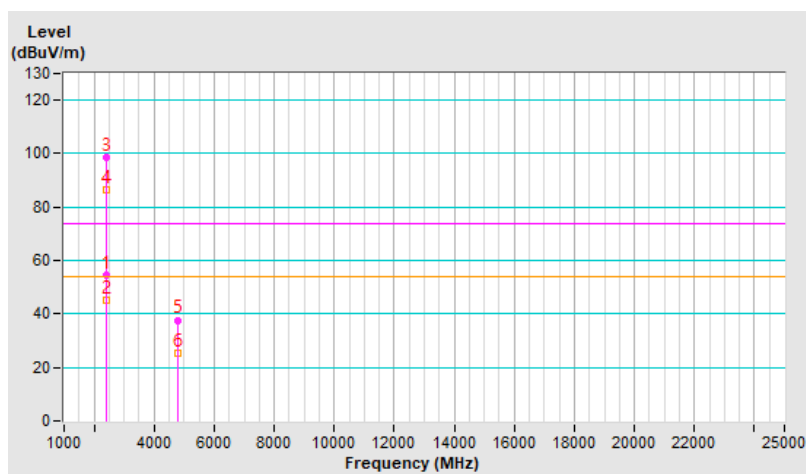

<b>RF Mode</b>	GFSK	<b>Channel</b>	CH 1 : 2403 MHz
<b>Frequency Range</b>	1 GHz ~ 25 GHz	<b>Detector Function &amp; Bandwidth</b>	Peak (PK), RB = 1 MHz, VB = 3 MHz RMS (AV), RB = 1 MHz, VB = 3 MHz
<b>Input Power (System)</b>	120 Vac, 60 Hz	<b>Environmental Conditions</b>	28°C, 75% RH
<b>Tested By</b>	Louis Yang		

Antenna Polarity & Test Distance : Vertical at 3 m								
No	Frequency (MHz)	Emission Level (dBuV/m)	Limit (dBuV/m)	Margin (dB)	Antenna Height (m)	Table Angle (Degree)	Raw Value (dBuV)	Correction Factor (dB/m)
1	2390.00	54.7 PK	74.0	-19.3	1.00 V	124	57.4	-2.7
2	2390.00	44.5 AV	54.0	-9.5	1.00 V	124	47.2	-2.7
3	*2403.00	95.5 PK			1.00 V	124	98.2	-2.7
4	*2403.00	83.2 AV			1.00 V	124	85.9	-2.7
5	4806.00	42.8 PK	74.0	-31.2	1.03 V	221	41.3	1.5
6	4806.00	30.5 AV	54.0	-23.5	1.03 V	221	29.0	1.5

**Remarks:**

1. Emission Level(dBuV/m) = Raw Value(dBuV) + Correction Factor(dB/m)
2. Correction Factor(dB/m) = Antenna Factor(dB/m) + Cable Factor(dB) – Pre-Amplifier Factor(dB)
3. Margin value = Emission Level – Limit value
4. The other emission levels were very low against the limit.
5. " \* " : Fundamental frequency, the limit was restricted at the RF Output Power.
6. The average value of fundamental and harmonic frequency is: Average = Peak value + 20 log(Duty cycle) Where the duty cycle correction factor is calculated from following formula:  
 $20 \log(\text{Duty cycle}) = 20 \log(0.188 \text{ ms} / 0.779 \text{ ms}) = -12.3 \text{ dB}$

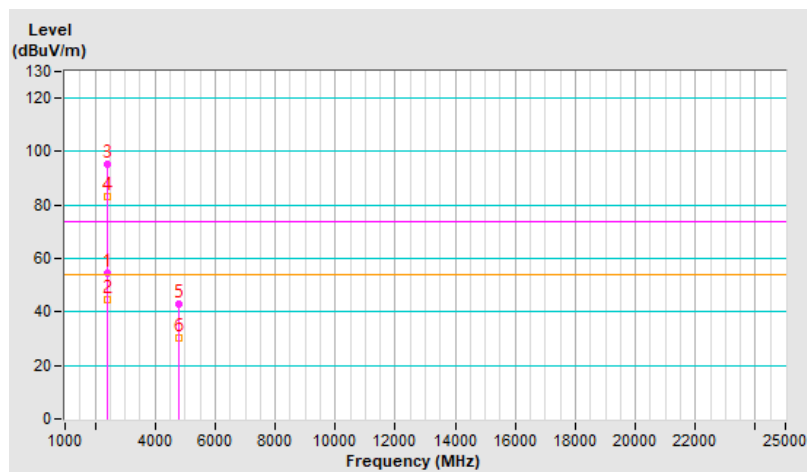

<b>RF Mode</b>	GFSK	<b>Channel</b>	CH 40 : 2442 MHz
<b>Frequency Range</b>	1 GHz ~ 25 GHz	<b>Detector Function &amp; Bandwidth</b>	Peak (PK), RB = 1 MHz, VB = 3 MHz RMS (AV), RB = 1 MHz, VB = 3 MHz
<b>Input Power (System)</b>	120 Vac, 60 Hz	<b>Environmental Conditions</b>	28°C, 75% RH
<b>Tested By</b>	Louis Yang		

Antenna Polarity & Test Distance : Horizontal at 3 m								
No	Frequency (MHz)	Emission Level (dBuV/m)	Limit (dBuV/m)	Margin (dB)	Antenna Height (m)	Table Angle (Degree)	Raw Value (dBuV)	Correction Factor (dB/m)
1	*2442.00	99.1 PK			1.02 H	94	101.7	-2.6
2	*2442.00	86.8 AV			1.02 H	94	89.4	-2.6
3	4884.00	37.7 PK	74.0	-36.3	1.00 H	334	36.2	1.5
4	4884.00	25.4 AV	54.0	-28.6	1.00 H	334	23.9	1.5
5	7326.00	48.0 PK	74.0	-26.0	1.06 H	101	40.8	7.2
6	7326.00	35.8 AV	54.0	-18.2	1.06 H	101	28.6	7.2

**Remarks:**

1. Emission Level(dBuV/m) = Raw Value(dBuV) + Correction Factor(dB/m)
2. Correction Factor(dB/m) = Antenna Factor(dB/m) + Cable Factor(dB) – Pre-Amplifier Factor(dB)
3. Margin value = Emission Level – Limit value
4. The other emission levels were very low against the limit.
5. " \* " : Fundamental frequency, the limit was restricted at the RF Output Power.
6. The average value of fundamental and harmonic frequency is: Average = Peak value + 20 log(Duty cycle) Where the duty cycle correction factor is calculated from following formula:  
 $20 \log(\text{Duty cycle}) = 20 \log(0.188 \text{ ms} / 0.779 \text{ ms}) = -12.3 \text{ dB}$

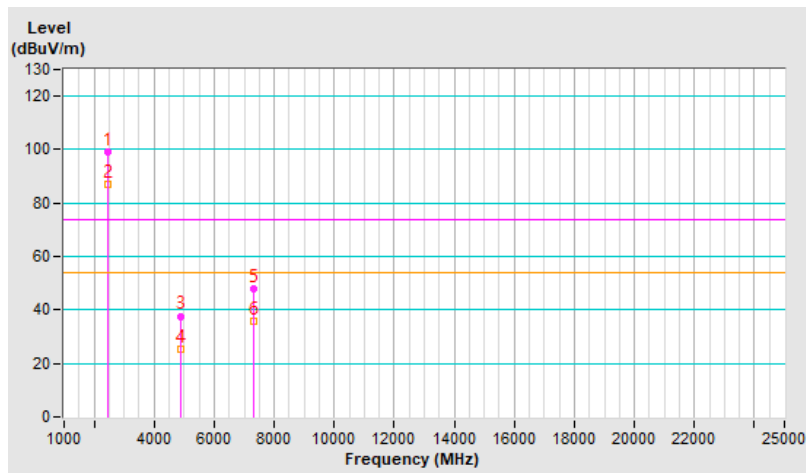

<b>RF Mode</b>	GFSK	<b>Channel</b>	CH 40 : 2442 MHz
<b>Frequency Range</b>	1 GHz ~ 25 GHz	<b>Detector Function &amp; Bandwidth</b>	Peak (PK), RB = 1 MHz, VB = 3 MHz RMS (AV), RB = 1 MHz, VB = 3 MHz
<b>Input Power (System)</b>	120 Vac, 60 Hz	<b>Environmental Conditions</b>	28°C, 75% RH
<b>Tested By</b>	Louis Yang		

Antenna Polarity & Test Distance : Vertical at 3 m								
No	Frequency (MHz)	Emission Level (dBuV/m)	Limit (dBuV/m)	Margin (dB)	Antenna Height (m)	Table Angle (Degree)	Raw Value (dBuV)	Correction Factor (dB/m)
1	*2442.00	95.8 PK			1.02 V	110	98.4	-2.6
2	*2442.00	83.5 AV			1.02 V	110	86.1	-2.6
3	4884.00	43.1 PK	74.0	-30.9	1.00 V	216	41.6	1.5
4	4884.00	30.8 AV	54.0	-23.2	1.00 V	216	29.3	1.5
5	7326.00	47.3 PK	74.0	-26.7	1.13 V	211	40.1	7.2
6	7326.00	35.0 AV	54.0	-19.0	1.13 V	211	27.8	7.2

**Remarks:**

1. Emission Level(dBuV/m) = Raw Value(dBuV) + Correction Factor(dB/m)
2. Correction Factor(dB/m) = Antenna Factor(dB/m) + Cable Factor(dB) – Pre-Amplifier Factor(dB)
3. Margin value = Emission Level – Limit value
4. The other emission levels were very low against the limit.
5. " \* " : Fundamental frequency, the limit was restricted at the RF Output Power.
6. The average value of fundamental and harmonic frequency is: Average = Peak value + 20 log(Duty cycle) Where the duty cycle correction factor is calculated from following formula:  
 $20 \log(\text{Duty cycle}) = 20 \log(0.188 \text{ ms} / 0.779 \text{ ms}) = -12.3 \text{ dB}$

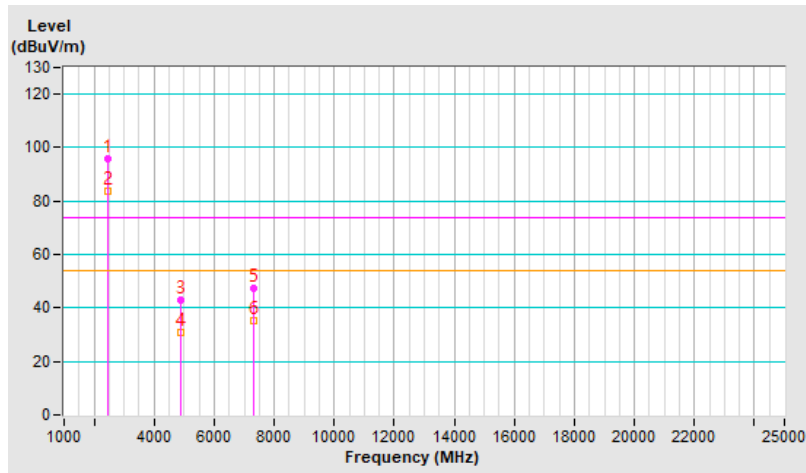



<b>RF Mode</b>	GFSK	<b>Channel</b>	CH 77 : 2479 MHz
<b>Frequency Range</b>	1 GHz ~ 25 GHz	<b>Detector Function &amp; Bandwidth</b>	Peak (PK), RB = 1 MHz, VB = 3 MHz RMS (AV), RB = 1 MHz, VB = 3 MHz
<b>Input Power (System)</b>	120 Vac, 60 Hz	<b>Environmental Conditions</b>	28°C, 75% RH
<b>Tested By</b>	Louis Yang		

Antenna Polarity & Test Distance : Horizontal at 3 m								
No	Frequency (MHz)	Emission Level (dBuV/m)	Limit (dBuV/m)	Margin (dB)	Antenna Height (m)	Table Angle (Degree)	Raw Value (dBuV)	Correction Factor (dB/m)
1	*2479.00	97.8 PK			1.22 H	338	100.5	-2.7
2	*2479.00	85.5 AV			1.22 H	338	88.2	-2.7
3	2483.50	54.4 PK	74.0	-19.6	1.22 H	338	57.1	-2.7
4	2483.50	45.0 AV	54.0	-9.0	1.22 H	338	47.7	-2.7
5	4958.00	37.6 PK	74.0	-36.4	1.00 H	345	35.9	1.7
6	4958.00	25.3 AV	54.0	-28.7	1.00 H	345	23.6	1.7
7	7437.00	47.7 PK	74.0	-26.3	1.08 H	99	40.3	7.4
8	7437.00	35.4 AV	54.0	-18.6	1.08 H	99	28.0	7.4

**Remarks:**

1. Emission Level(dBuV/m) = Raw Value(dBuV) + Correction Factor(dB/m)
2. Correction Factor(dB/m) = Antenna Factor(dB/m) + Cable Factor(dB) – Pre-Amplifier Factor(dB)
3. Margin value = Emission Level – Limit value
4. The other emission levels were very low against the limit.
5. " \* ": Fundamental frequency, the limit was restricted at the RF Output Power.
6. The average value of fundamental and harmonic frequency is: Average = Peak value + 20 log(Duty cycle) Where the duty cycle correction factor is calculated from following formula:  
 $20 \log(\text{Duty cycle}) = 20 \log(0.188 \text{ ms} / 0.779 \text{ ms}) = -12.3 \text{ dB}$

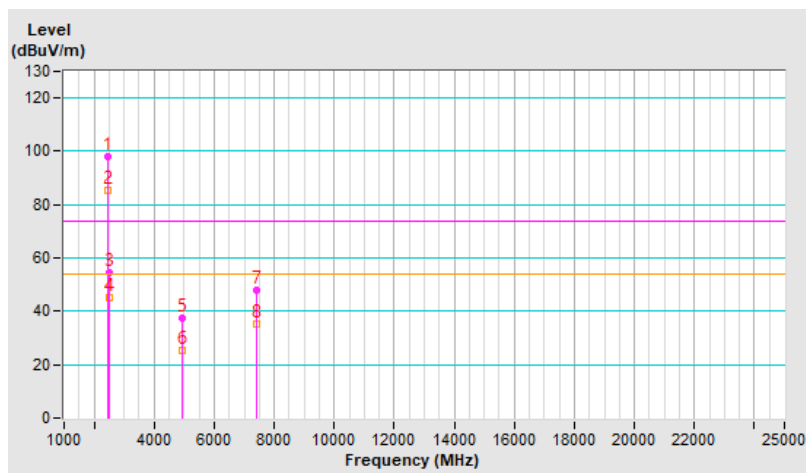

<b>RF Mode</b>	GFSK	<b>Channel</b>	CH 77 : 2479 MHz
<b>Frequency Range</b>	1 GHz ~ 25 GHz	<b>Detector Function &amp; Bandwidth</b>	Peak (PK), RB = 1 MHz, VB = 3 MHz RMS (AV), RB = 1 MHz, VB = 3 MHz
<b>Input Power (System)</b>	120 Vac, 60 Hz	<b>Environmental Conditions</b>	28°C, 75% RH
<b>Tested By</b>	Louis Yang		

Antenna Polarity & Test Distance : Vertical at 3 m								
No	Frequency (MHz)	Emission Level (dBuV/m)	Limit (dBuV/m)	Margin (dB)	Antenna Height (m)	Table Angle (Degree)	Raw Value (dBuV)	Correction Factor (dB/m)
1	*2479.00	93.8 PK			1.23 V	115	96.5	-2.7
2	*2479.00	81.5 AV			1.23 V	115	84.2	-2.7
3	2483.50	53.8 PK	74.0	-20.2	1.23 V	115	56.5	-2.7
4	2483.50	44.3 AV	54.0	-9.7	1.23 V	115	47.0	-2.7
5	4958.00	43.7 PK	74.0	-30.3	1.03 V	228	42.0	1.7
6	4958.00	31.4 AV	54.0	-22.6	1.03 V	228	29.7	1.7
7	7437.00	47.8 PK	74.0	-26.2	1.12 V	208	40.4	7.4
8	7437.00	35.5 AV	54.0	-18.5	1.12 V	208	28.1	7.4

**Remarks:**

1. Emission Level(dBuV/m) = Raw Value(dBuV) + Correction Factor(dB/m)
2. Correction Factor(dB/m) = Antenna Factor(dB/m) + Cable Factor(dB) – Pre-Amplifier Factor(dB)
3. Margin value = Emission Level – Limit value
4. The other emission levels were very low against the limit.
5. " \* ": Fundamental frequency, the limit was restricted at the RF Output Power.
6. The average value of fundamental and harmonic frequency is: Average = Peak value + 20 log(Duty cycle) Where the duty cycle correction factor is calculated from following formula:  
 $20 \log(\text{Duty cycle}) = 20 \log(0.188 \text{ ms} / 0.779 \text{ ms}) = -12.3 \text{ dB}$

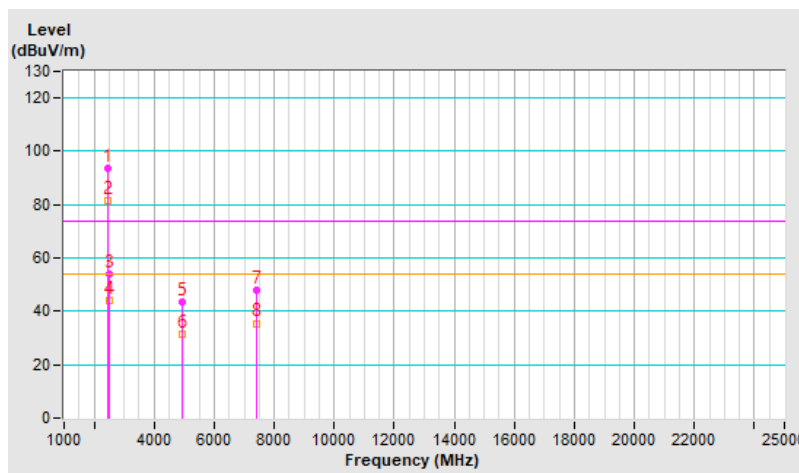

Mode B

<b>RF Mode</b>	GFSK	<b>Channel</b>	CH 1 : 2403 MHz
<b>Frequency Range</b>	1 GHz ~ 25 GHz	<b>Detector Function &amp; Bandwidth</b>	Peak (PK), RB = 1 MHz, VB = 3 MHz RMS (AV), RB = 1 MHz, VB = 3 MHz
<b>Input Power (System)</b>	120 Vac, 60 Hz	<b>Environmental Conditions</b>	28°C, 75% RH
<b>Tested By</b>	Louis Yang		

Antenna Polarity & Test Distance : Horizontal at 3 m								
No	Frequency (MHz)	Emission Level (dBuV/m)	Limit (dBuV/m)	Margin (dB)	Antenna Height (m)	Table Angle (Degree)	Raw Value (dBuV)	Correction Factor (dB/m)
1	2390.00	55.2 PK	74.0	-18.8	1.00 H	82	57.9	-2.7
2	2390.00	45.3 AV	54.0	-8.7	1.00 H	82	48.0	-2.7
3	*2403.00	98.0 PK			1.00 H	82	100.7	-2.7
4	*2403.00	85.6 AV			1.00 H	82	88.3	-2.7
5	4806.00	43.2 PK	74.0	-30.8	1.00 H	334	41.7	1.5
6	4806.00	30.8 AV	54.0	-23.2	1.00 H	334	29.3	1.5

Remarks:

1. Emission Level(dBuV/m) = Raw Value(dBuV) + Correction Factor(dB/m)
2. Correction Factor(dB/m) = Antenna Factor(dB/m) + Cable Factor(dB) – Pre-Amplifier Factor(dB)
3. Margin value = Emission Level – Limit value
4. The other emission levels were very low against the limit.
5. " \* ": Fundamental frequency, the limit was restricted at the RF Output Power.
6. The average value of fundamental and harmonic frequency is: Average = Peak value + 20 log(Duty cycle) Where the duty cycle correction factor is calculated from following formula:  
 $20 \log(\text{Duty cycle}) = 20 \log(0.188 \text{ ms} / 0.782 \text{ ms}) = -12.4 \text{ dB}$

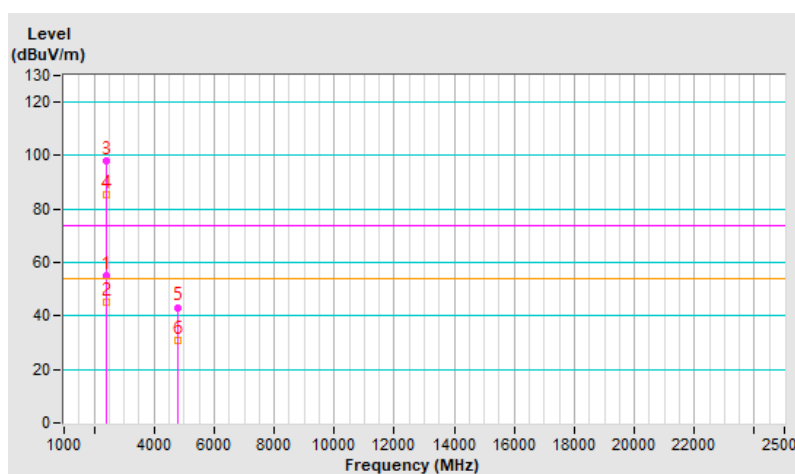

<b>RF Mode</b>	GFSK	<b>Channel</b>	CH 1 : 2403 MHz
<b>Frequency Range</b>	1 GHz ~ 25 GHz	<b>Detector Function &amp; Bandwidth</b>	Peak (PK), RB = 1 MHz, VB = 3 MHz RMS (AV), RB = 1 MHz, VB = 3 MHz
<b>Input Power (System)</b>	120 Vac, 60 Hz	<b>Environmental Conditions</b>	28°C, 75% RH
<b>Tested By</b>	Louis Yang		

Antenna Polarity & Test Distance : Vertical at 3 m								
No	Frequency (MHz)	Emission Level (dBuV/m)	Limit (dBuV/m)	Margin (dB)	Antenna Height (m)	Table Angle (Degree)	Raw Value (dBuV)	Correction Factor (dB/m)
1	2390.00	54.3 PK	74.0	-19.7	1.00 V	115	57.0	-2.7
2	<b>2390.00</b>	<b>45.4 AV</b>	<b>54.0</b>	<b>-8.6</b>	<b>1.00 V</b>	<b>115</b>	<b>48.1</b>	<b>-2.7</b>
3	*2403.00	97.2 PK			1.00 V	115	99.9	-2.7
4	*2403.00	84.8 AV			1.00 V	115	87.5	-2.7
5	4806.00	44.1 PK	74.0	-29.9	1.00 V	218	42.6	1.5
6	4806.00	31.7 AV	54.0	-22.3	1.00 V	218	30.2	1.5

**Remarks:**

1. Emission Level(dBuV/m) = Raw Value(dBuV) + Correction Factor(dB/m)
2. Correction Factor(dB/m) = Antenna Factor(dB/m) + Cable Factor(dB) – Pre-Amplifier Factor(dB)
3. Margin value = Emission Level – Limit value
4. The other emission levels were very low against the limit.
5. " \* " : Fundamental frequency, the limit was restricted at the RF Output Power.
6. The average value of fundamental and harmonic frequency is: Average = Peak value + 20 log(Duty cycle) Where the duty cycle correction factor is calculated from following formula:  
 $20 \log(\text{Duty cycle}) = 20 \log(0.188 \text{ ms} / 0.782 \text{ ms}) = -12.4 \text{ dB}$

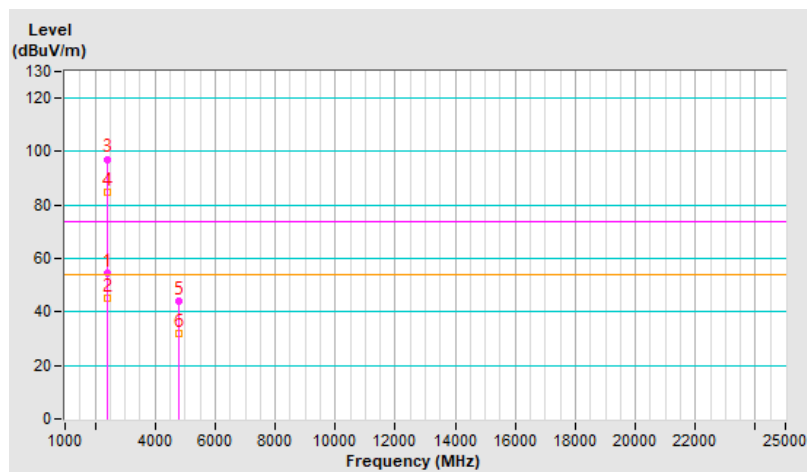

<b>RF Mode</b>	GFSK	<b>Channel</b>	CH 40 : 2442 MHz
<b>Frequency Range</b>	1 GHz ~ 25 GHz	<b>Detector Function &amp; Bandwidth</b>	Peak (PK), RB = 1 MHz, VB = 3 MHz RMS (AV), RB = 1 MHz, VB = 3 MHz
<b>Input Power (System)</b>	120 Vac, 60 Hz	<b>Environmental Conditions</b>	28°C, 75% RH
<b>Tested By</b>	Louis Yang		

Antenna Polarity & Test Distance : Horizontal at 3 m								
No	Frequency (MHz)	Emission Level (dBuV/m)	Limit (dBuV/m)	Margin (dB)	Antenna Height (m)	Table Angle (Degree)	Raw Value (dBuV)	Correction Factor (dB/m)
1	*2442.00	98.3 PK			1.04 H	74	100.9	-2.6
2	*2442.00	85.9 AV			1.04 H	74	88.5	-2.6
3	4884.00	42.7 PK	74.0	-31.3	1.00 H	338	41.2	1.5
4	4884.00	30.3 AV	54.0	-23.7	1.00 H	338	28.8	1.5
5	7326.00	43.7 PK	74.0	-30.3	1.03 H	95	36.5	7.2
6	7326.00	31.3 AV	54.0	-22.7	1.03 H	95	24.1	7.2

**Remarks:**

1. Emission Level(dBuV/m) = Raw Value(dBuV) + Correction Factor(dB/m)
2. Correction Factor(dB/m) = Antenna Factor(dB/m) + Cable Factor(dB) – Pre-Amplifier Factor(dB)
3. Margin value = Emission Level – Limit value
4. The other emission levels were very low against the limit.
5. " \* " : Fundamental frequency, the limit was restricted at the RF Output Power.
6. The average value of fundamental and harmonic frequency is: Average = Peak value + 20 log(Duty cycle) Where the duty cycle correction factor is calculated from following formula:  
 $20 \log(\text{Duty cycle}) = 20 \log(0.188 \text{ ms} / 0.782 \text{ ms}) = -12.4 \text{ dB}$

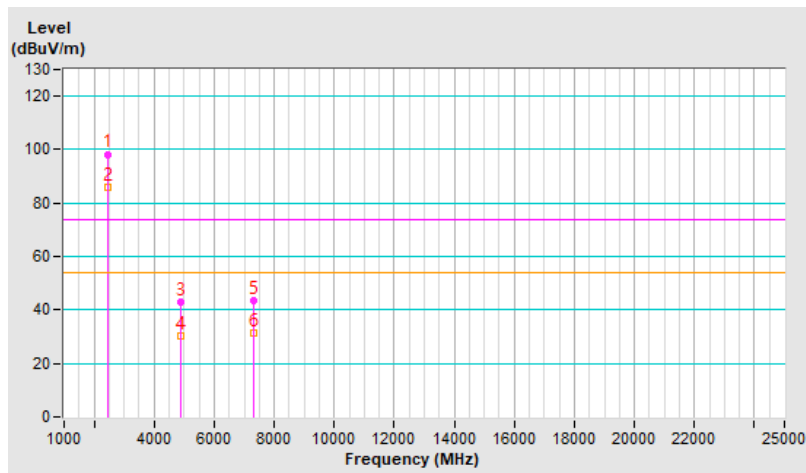

<b>RF Mode</b>	GFSK	<b>Channel</b>	CH 40 : 2442 MHz
<b>Frequency Range</b>	1 GHz ~ 25 GHz	<b>Detector Function &amp; Bandwidth</b>	Peak (PK), RB = 1 MHz, VB = 3 MHz RMS (AV), RB = 1 MHz, VB = 3 MHz
<b>Input Power (System)</b>	120 Vac, 60 Hz	<b>Environmental Conditions</b>	28°C, 75% RH
<b>Tested By</b>	Louis Yang		

Antenna Polarity & Test Distance : Vertical at 3 m								
No	Frequency (MHz)	Emission Level (dBuV/m)	Limit (dBuV/m)	Margin (dB)	Antenna Height (m)	Table Angle (Degree)	Raw Value (dBuV)	Correction Factor (dB/m)
1	*2442.00	96.6 PK			1.06 V	109	99.2	-2.6
2	*2442.00	84.2 AV			1.06 V	109	86.8	-2.6
3	4884.00	43.7 PK	74.0	-30.3	1.04 V	217	42.2	1.5
4	4884.00	31.3 AV	54.0	-22.7	1.04 V	217	29.8	1.5
5	7326.00	46.4 PK	74.0	-27.6	1.09 V	161	39.2	7.2
6	7326.00	34.0 AV	54.0	-20.0	1.09 V	161	26.8	7.2

**Remarks:**

1. Emission Level(dBuV/m) = Raw Value(dBuV) + Correction Factor(dB/m)
2. Correction Factor(dB/m) = Antenna Factor(dB/m) + Cable Factor(dB) – Pre-Amplifier Factor(dB)
3. Margin value = Emission Level – Limit value
4. The other emission levels were very low against the limit.
5. " \* " : Fundamental frequency, the limit was restricted at the RF Output Power.
6. The average value of fundamental and harmonic frequency is: Average = Peak value + 20 log(Duty cycle) Where the duty cycle correction factor is calculated from following formula:  
 $20 \log(\text{Duty cycle}) = 20 \log(0.188 \text{ ms} / 0.782 \text{ ms}) = -12.4 \text{ dB}$

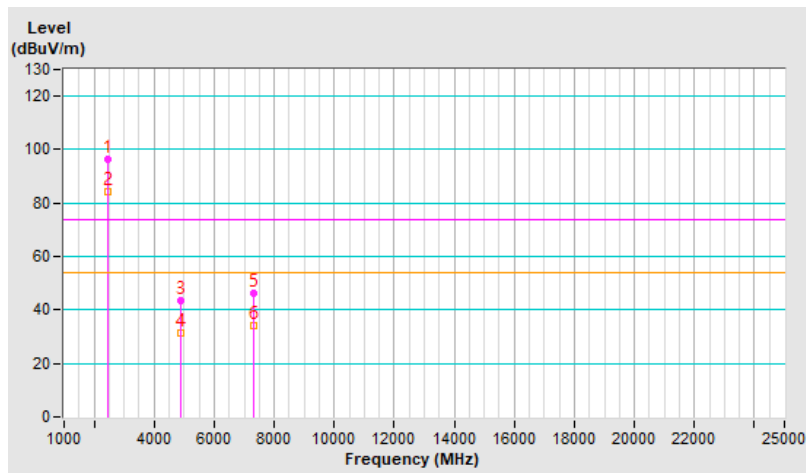

<b>RF Mode</b>	GFSK	<b>Channel</b>	CH 77 : 2479 MHz
<b>Frequency Range</b>	1 GHz ~ 25 GHz	<b>Detector Function &amp; Bandwidth</b>	Peak (PK), RB = 1 MHz, VB = 3 MHz RMS (AV), RB = 1 MHz, VB = 3 MHz
<b>Input Power (System)</b>	120 Vac, 60 Hz	<b>Environmental Conditions</b>	28°C, 75% RH
<b>Tested By</b>	Louis Yang		

Antenna Polarity & Test Distance : Horizontal at 3 m								
No	Frequency (MHz)	Emission Level (dBuV/m)	Limit (dBuV/m)	Margin (dB)	Antenna Height (m)	Table Angle (Degree)	Raw Value (dBuV)	Correction Factor (dB/m)
1	*2479.00	92.4 PK			1.00 H	338	95.1	-2.7
2	*2479.00	80.0 AV			1.00 H	338	82.7	-2.7
3	2483.50	54.5 PK	74.0	-19.5	1.00 H	338	57.2	-2.7
4	2483.50	45.0 AV	54.0	-9.0	1.00 H	338	47.7	-2.7
5	4958.00	42.5 PK	74.0	-31.5	1.00 H	353	40.8	1.7
6	4958.00	30.1 AV	54.0	-23.9	1.00 H	353	28.4	1.7
7	7437.00	43.5 PK	74.0	-30.5	1.04 H	102	36.1	7.4
8	7437.00	31.1 AV	54.0	-22.9	1.04 H	102	23.7	7.4

**Remarks:**

1. Emission Level(dBuV/m) = Raw Value(dBuV) + Correction Factor(dB/m)
2. Correction Factor(dB/m) = Antenna Factor(dB/m) + Cable Factor(dB) – Pre-Amplifier Factor(dB)
3. Margin value = Emission Level – Limit value
4. The other emission levels were very low against the limit.
5. " \* ": Fundamental frequency, the limit was restricted at the RF Output Power.
6. The average value of fundamental and harmonic frequency is: Average = Peak value + 20 log(Duty cycle) Where the duty cycle correction factor is calculated from following formula:  
 $20 \log(\text{Duty cycle}) = 20 \log(0.188 \text{ ms} / 0.782 \text{ ms}) = -12.4 \text{ dB}$

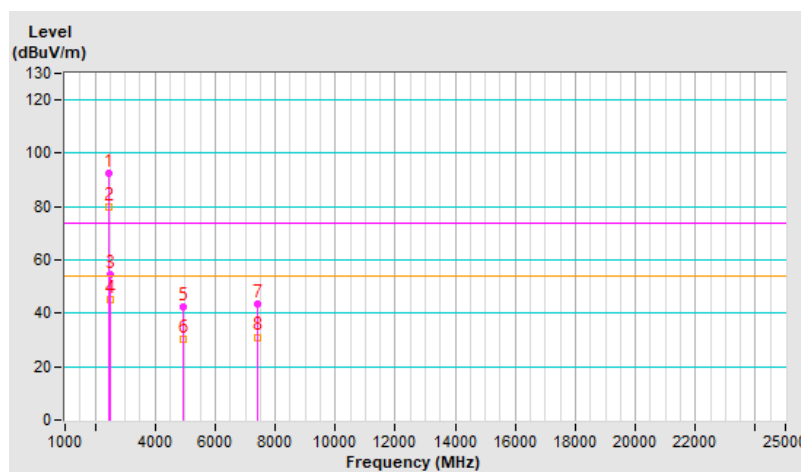

<b>RF Mode</b>	GFSK	<b>Channel</b>	CH 77 : 2479 MHz
<b>Frequency Range</b>	1 GHz ~ 25 GHz	<b>Detector Function &amp; Bandwidth</b>	Peak (PK), RB = 1 MHz, VB = 3 MHz RMS (AV), RB = 1 MHz, VB = 3 MHz
<b>Input Power (System)</b>	120 Vac, 60 Hz	<b>Environmental Conditions</b>	28°C, 75% RH
<b>Tested By</b>	Louis Yang		

Antenna Polarity & Test Distance : Vertical at 3 m								
No	Frequency (MHz)	Emission Level (dBUV/m)	Limit (dBUV/m)	Margin (dB)	Antenna Height (m)	Table Angle (Degree)	Raw Value (dBUV)	Correction Factor (dB/m)
1	*2479.00	90.5 PK			1.02 V	115	93.2	-2.7
2	*2479.00	78.1 AV			1.02 V	115	80.8	-2.7
3	2483.50	54.2 PK	74.0	-19.8	1.02 V	115	56.9	-2.7
4	2483.50	45.0 AV	54.0	-9.0	1.02 V	115	47.7	-2.7
5	4958.00	43.3 PK	74.0	-30.7	1.08 V	224	41.6	1.7
6	4958.00	30.9 AV	54.0	-23.1	1.08 V	224	29.2	1.7
7	7437.00	46.6 PK	74.0	-27.4	1.15 V	159	39.2	7.4
8	7437.00	34.2 AV	54.0	-19.8	1.15 V	159	26.8	7.4

**Remarks:**

1. Emission Level(dBUV/m) = Raw Value(dBUV) + Correction Factor(dB/m)
2. Correction Factor(dB/m) = Antenna Factor(dB/m) + Cable Factor(dB) – Pre-Amplifier Factor(dB)
3. Margin value = Emission Level – Limit value
4. The other emission levels were very low against the limit.
5. " \* ": Fundamental frequency, the limit was restricted at the RF Output Power.
6. The average value of fundamental and harmonic frequency is: Average = Peak value + 20 log(Duty cycle) Where the duty cycle correction factor is calculated from following formula:  
 $20 \log(\text{Duty cycle}) = 20 \log(0.188 \text{ ms} / 0.782 \text{ ms}) = -12.4 \text{ dB}$

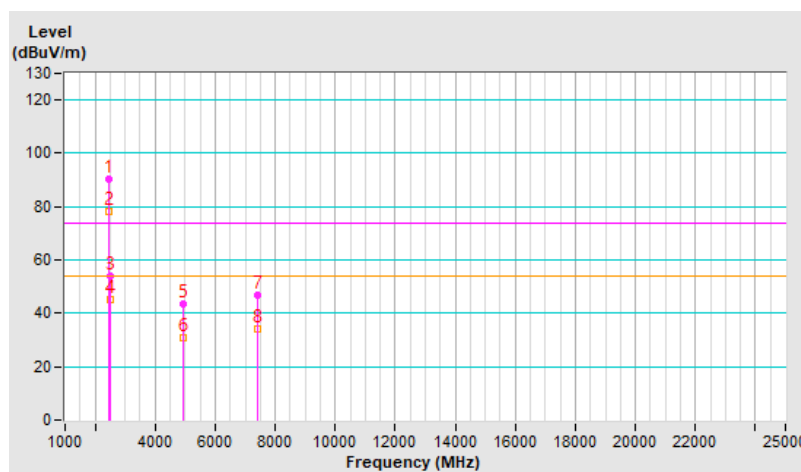



Plot of Band Edge\_Mode A

Mode A

Frequency Range	2.31 GHz ~ 2.5 GHz	Detector Function & Bandwidth	Peak (PK), RB = 1 MHz, VB = 3 MHz RMS (AV), RB = 1 MHz, VB = 3 MHz
-----------------	--------------------	-------------------------------	---

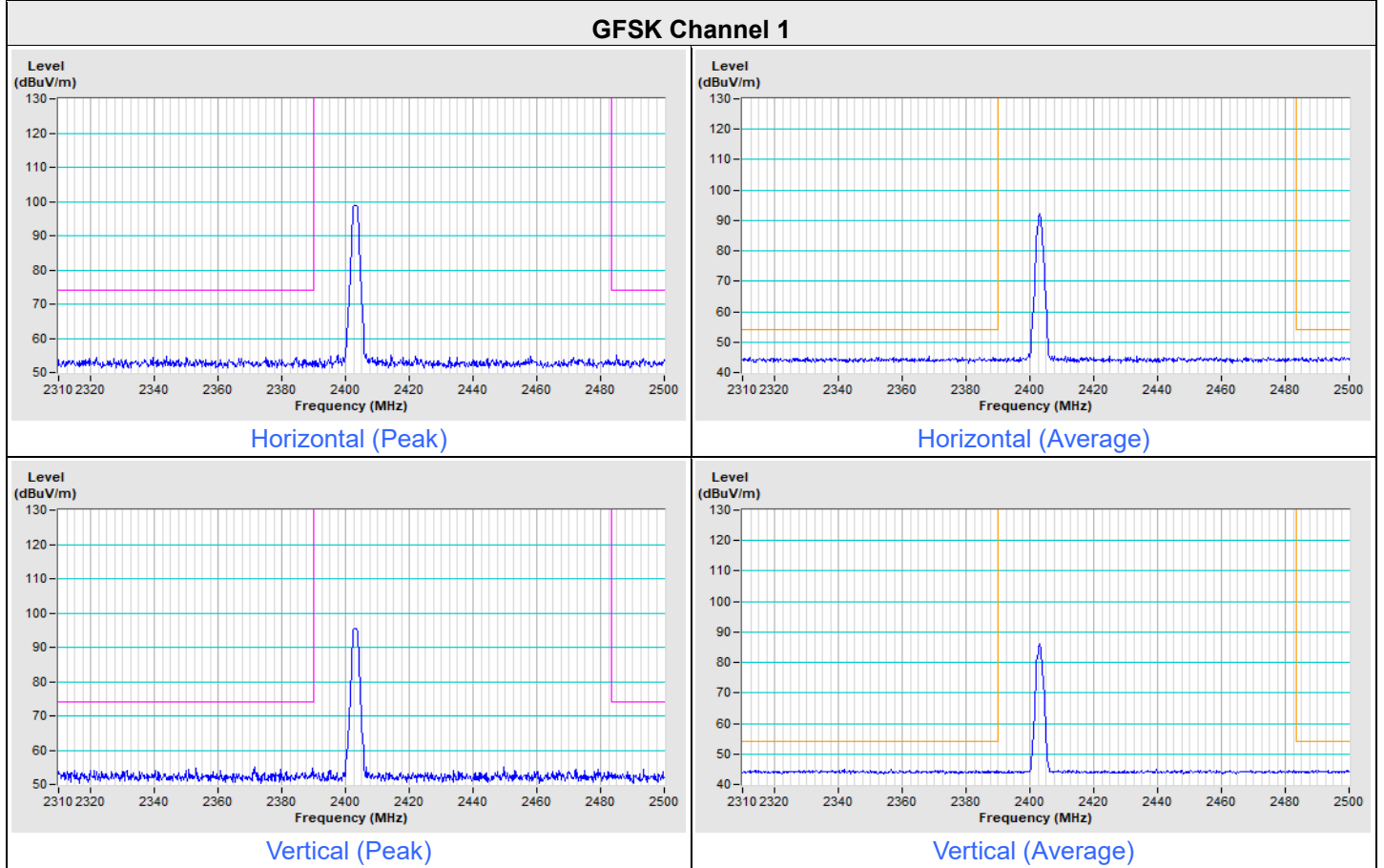

### GFSK Channel 77

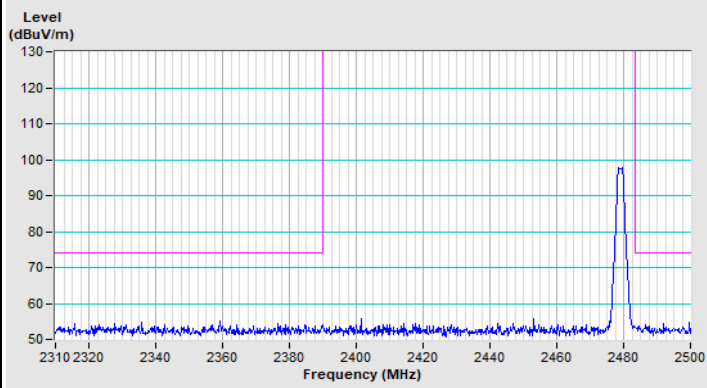

Horizontal (Peak)

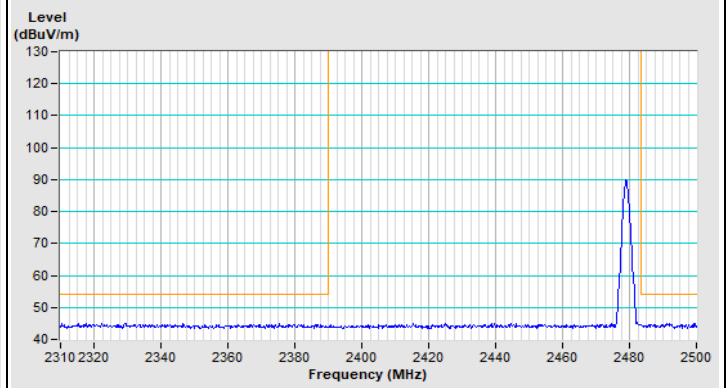

Horizontal (Average)

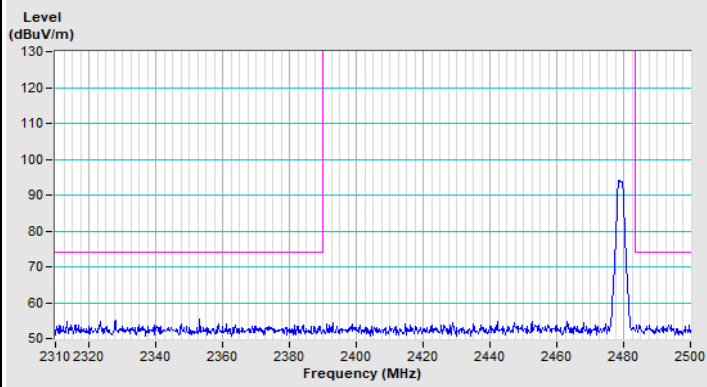

Vertical (Peak)

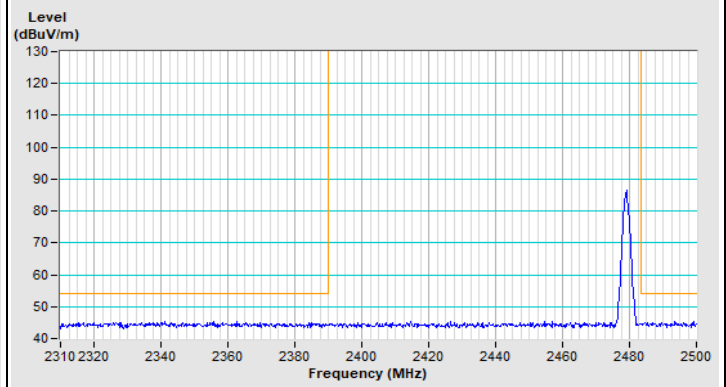

Vertical (Average)

### Plot of Band Edge\_Mode B

#### Mode B

Frequency Range	2.31 GHz ~ 2.5 GHz	Detector Function & Bandwidth	Peak (PK), RB = 1 MHz, VB = 3 MHz RMS (AV), RB = 1 MHz, VB = 3 MHz
-----------------	--------------------	-------------------------------	---

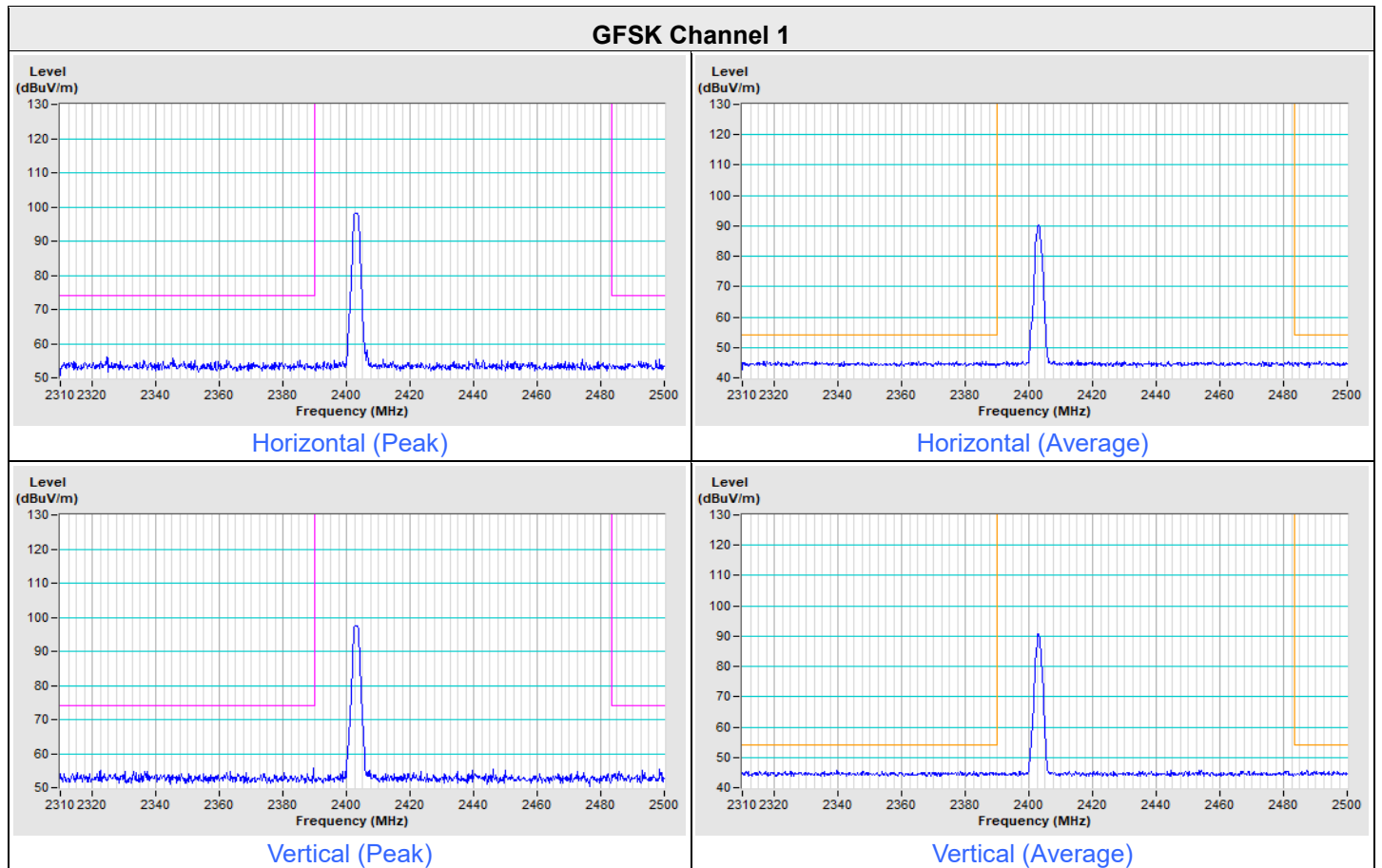

### GFSK Channel 77

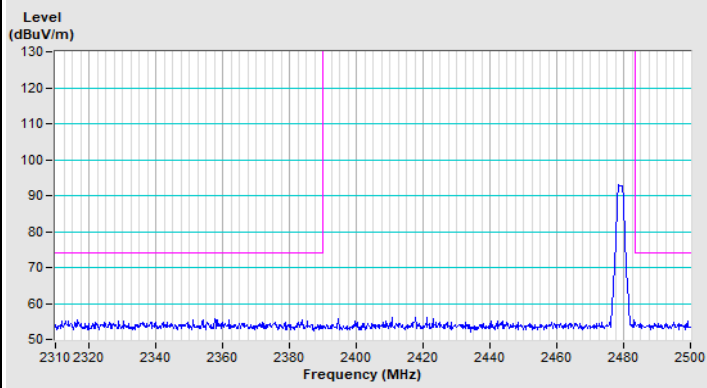

Horizontal (Peak)

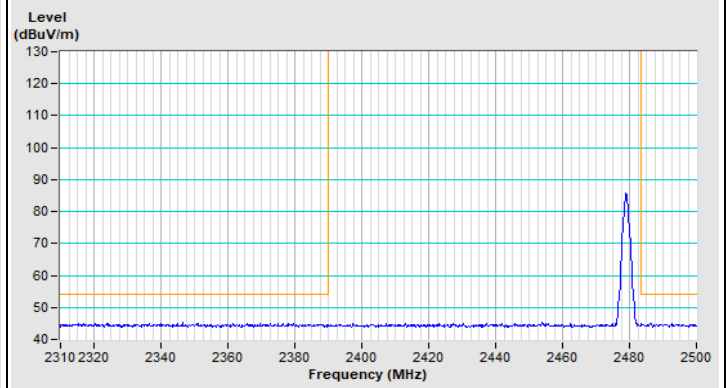

Horizontal (Average)

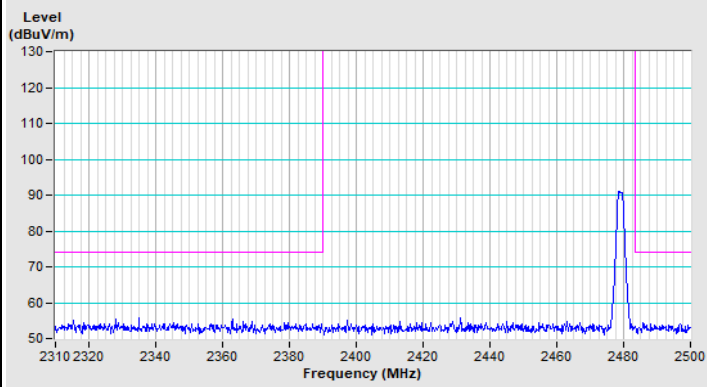

Vertical (Peak)

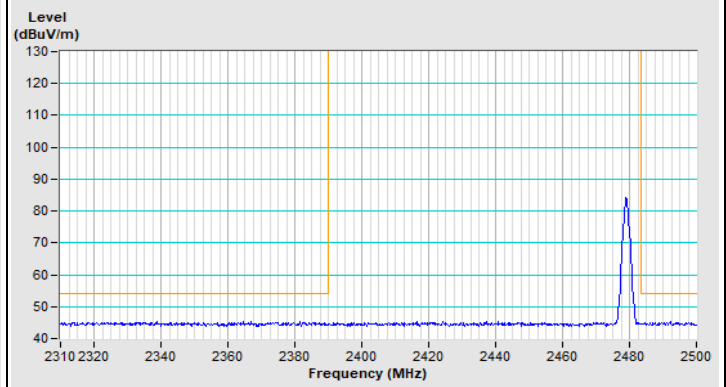

Vertical (Average)

## 8 Pictures of Test Arrangements

Please refer to the attached file (Test Setup Photo)

## 9 Information of the Testing Laboratories

We, Bureau Veritas Consumer Products Services (H.K.) Ltd., Taoyuan Branch, were founded in 1988 to provide our best service in EMC, Radio, Telecom and Safety consultation. Our laboratories are FCC recognized accredited test firms and accredited according to ISO/IEC 17025.

If you have any comments, please feel free to contact us at the following:

**Lin Kou EMC/RF Lab**

Tel: 886-2-26052180

Fax: 886-2-26051924

**Hsin Chu EMC/RF/Telecom Lab**

Tel: 886-3-6668565

Fax: 886-3-6668323

**Hwa Ya EMC/RF/Safety Lab**

Tel: 886-3-3183232

Fax: 886-3-3270892

**Email:** [service.adt@bureauveritas.com](mailto:service.adt@bureauveritas.com)

**Web Site:** <http://ee.bureauveritas.com.tw>

The address and road map of all our labs can be found in our web site also.

--- END ---