

FCC Test Report

Report No.: RFBDKG-WTW-P21050197

FCC ID: JNZYR0084

Test Model: YR0084

Received Date: May 06, 2021

Test Date: May 18 to 24, 2021

Issued Date: June 16, 2021

Applicant: LOGITECH FAR EAST LTD.

Address: 7700 Gateway Boulevard Newark California United States

Issued By: Bureau Veritas Consumer Products Services (H.K.) Ltd., Taoyuan Branch
Hsin Chu Laboratory

Lab Address: E-2, No.1, Li Hsin 1st Road, Hsinchu Science Park, Hsinchu City 300,
Taiwan

Test Location: E-2, No.1, Li Hsin 1st Road, Hsinchu Science Park, Hsinchu City 300,
Taiwan

**FCC Registration /
Designation Number:** 723255 / TW2022



This report is for your exclusive use. Any copying or replication of this report to or for any other person or entity, or use of our name or trademark, is permitted only with our prior written permission. This report sets forth our findings solely with respect to the test samples identified herein. The results set forth in this report are not indicative or representative of the quality or characteristics of the lot from which a test sample was taken or any similar or identical product unless specifically and expressly noted. Our report includes all of the tests requested by you and the results thereof based upon the information that you provided to us. You have 60 days from date of issuance of this report to notify us of any material error or omission caused by our negligence, provided, however, that such notice shall be in writing and shall specifically address the issue you wish to raise. A failure to raise such issue within the prescribed time shall constitute your unqualified acceptance of the completeness of this report, the tests conducted and the correctness of the report contents. Unless specifically mentioned, the uncertainty of measurement has been explicitly taken into account to declare the compliance or non-compliance to the specification.

Table of Contents

Release Control Record	4
1 Certificate of Conformity	5
2 Summary of Test Results	6
2.1 Measurement Uncertainty	6
2.2 Modification Record	6
3 General Information	7
3.1 General Description of EUT	7
3.2 Description of Test Modes	9
3.2.1 Test Mode Applicability and Tested Channel Detail	10
3.3 Duty Cycle of Test Signal	12
3.4 Description of Support Units	13
3.4.1 Configuration of System under Test	13
3.5 General Description of Applied Standards and References	14
4 Test Types and Results	15
4.1 Radiated Emission and Bandedge Measurement	15
4.1.1 Limits of Radiated Emission and Bandedge Measurement	15
4.1.2 Test Instruments	16
4.1.3 Test Procedures	19
4.1.4 Deviation from Test Standard	19
4.1.5 Test Setup	20
4.1.6 EUT Operating Conditions	21
4.1.7 Test Results	22
4.2 Conducted Emission Measurement	38
4.2.1 Limits of Conducted Emission Measurement	38
4.2.2 Test Instruments	38
4.2.3 Test Procedures	39
4.2.4 Deviation from Test Standard	39
4.2.5 Test Setup	39
4.2.6 EUT Operating Conditions	39
4.2.7 Test Results	40
4.3 6dB Bandwidth Measurement	44
4.3.1 Limits of 6dB Bandwidth Measurement	44
4.3.2 Test Setup	44
4.3.3 Test Instruments	44
4.3.4 Test Procedure	44
4.3.5 Deviation from Test Standard	44
4.3.6 EUT Operating Conditions	44
4.3.7 Test Results	45
4.4 Conducted Output Power Measurement	47
4.4.1 Limits of Conducted Output Power Measurement	47
4.4.2 Test Setup	47
4.4.3 Test Instruments	47
4.4.4 Test Procedures	47
4.4.5 Deviation from Test Standard	47
4.4.6 EUT Operating Conditions	47
4.4.7 Test Results	48
4.5 Power Spectral Density Measurement	50
4.5.1 Limits of Power Spectral Density Measurement	50
4.5.2 Test Setup	50
4.5.3 Test Instruments	50
4.5.4 Test Procedure	50
4.5.5 Deviation from Test Standard	50
4.5.6 EUT Operating Condition	50

4.5.7 Test Results	51
4.6 Conducted Out of Band Emission Measurement	53
4.6.1 Limits of Conducted Out of Band Emission Measurement.....	53
4.6.2 Test Setup.....	53
4.6.3 Test Instruments	53
4.6.4 Test Procedure	53
4.6.5 Deviation from Test Standard	53
4.6.6 EUT Operating Condition	53
4.6.7 Test Results	54
5 Pictures of Test Arrangements.....	59
Annex A - Band-Edge Measurement.....	60
Appendix – Information of the Testing Laboratories	64

Release Control Record

Issue No.	Description	Date Issued
RFBDKG-WTW-P21050197	Original release.	June 16, 2021

1 Certificate of Conformity

Product: Wireless keyboard

Brand: Logitech

Test Model: YR0084

Sample Status: Engineering sample

Applicant: LOGITECH FAR EAST LTD.

Test Date: May 18 to 24, 2021

Standards: 47 CFR FCC Part 15, Subpart C (Section 15.247)
ANSI C63.10: 2013

The above equipment has been tested by **Bureau Veritas Consumer Products Services (H.K.) Ltd., Taoyuan Branch**, and found compliance with the requirement of the above standards. The test record, data evaluation & Equipment Under Test (EUT) configurations represented herein are true and accurate accounts of the measurements of the sample's EMC characteristics under the conditions specified in this report.

Prepared by : Vivian Huang , **Date:** June 16, 2021
Vivian Huang / Specialist

Approved by : Clark Lin , **Date:** June 16, 2021
Clark Lin / Technical Manager

2 Summary of Test Results

47 CFR FCC Part 15, Subpart C (Section 15.247)			
FCC Clause	Test Item	Result	Remarks
15.207	AC Power Conducted Emission	PASS	Meet the requirement of limit. Minimum passing margin is -19.13 dB at 0.50547 MHz.
15.205 / 15.209 / 15.247(d)	Radiated Emissions and Band Edge Measurement	PASS	Meet the requirement of limit. Minimum passing margin is -4.6 dB at 2488.35 MHz and 2490.65 MHz.
15.247(d)	Antenna Port Emission	PASS	Meet the requirement of limit.
15.247(a)(2)	6dB bandwidth	PASS	Meet the requirement of limit.
15.247(b)	Conducted power	PASS	Meet the requirement of limit.
15.247(e)	Power Spectral Density	PASS	Meet the requirement of limit.
15.203	Antenna Requirement	PASS	No antenna connector is used.

Note:

- For 2.4 GHz band compliance with rule 15.247(d) of the band-edge items, the test plots were recorded in Annex A.
- Determining compliance based on the results of the compliance measurement, not taking into account measurement instrumentation uncertainty.

2.1 Measurement Uncertainty

Where relevant, the following measurement uncertainty levels have been estimated for tests performed on the EUT as specified in CISPR 16-4-2:

Measurement	Frequency	Expanded Uncertainty (k=2) (\pm)
Conducted Emissions at mains ports	150kHz ~ 30MHz	1.9 dB
Conducted emissions	-	2.5 dB
Radiated Emissions up to 1 GHz	9kHz ~ 30MHz	3.1 dB
	30MHz ~ 1GHz	5.4 dB
Radiated Emissions above 1 GHz	1GHz ~ 18GHz	5.0 dB
	18GHz ~ 40GHz	5.3 dB

2.2 Modification Record

There were no modifications required for compliance.

3 General Information

3.1 General Description of EUT

Product	Wireless keyboard
Brand	Logitech
Test Model	YR0084
Status of EUT	Engineering sample
Power Supply Rating	DC 5V from USB interface or DC 3.7V from battery
Modulation Type	GFSK
Modulation Technology	DTS
Transfer Rate	BT-LE: Up to 2 Mbps (*Note 1)
Operating Frequency	BT-LE: 2.402 ~ 2.480 GHz (*Note 1)
Number of Channel	BT-LE: 40 (*Note 1)
Output Power	BT-LE function: BT-LE 1M: 2.382 mW BT-LE 2M: 2.377 mW logi bolt function: logi bolt 1M: 2.355 mW logi bolt 2M: 2.344 mW
Antenna Type	Refer to Note
Antenna Connector	Refer to Note
Accessory Device	NA
Cable Supplied	USB Cable Type A to Type C cable x 1 (Shielded, 1m), USB Cable Type C to Type C cable x 1 (Shielded, 1m)

Note:

1. BT-LE technique supports 1Mbps and 2Mbps data rates, both have been evaluated in this test report. Refer to "**section 3.2 Description of Test Modes**" for more detail specification.
2. This device have BT-LE and logi bolt functions. Logi Bolt is the same technology as BT-LE and is just a different marketing name.
3. The EUT may have a lot of colors for marketing requirement.
4. EUT uses either BT-LE or logi bolt technology. BT-LE and logi bolt may not transmit simultaneously.
5. The EUT must be supplied with a battery as the following table:

Brand	Model No.	Spec.
Springpower technology(ShenZhen)Co., Ltd or Logitech	802062 or 533-000200	3.7Vdc, 1130mAh, 4.181Wh

6. The antenna provided to the EUT, please refer to the following table:

Antenna Gain (dBi)	Frequency Range (GHz)	Antenna Type	Connector Type
2.25	2.4~2.4835	Printed Inverted-F antenna	None

7. For radiated emissions, the EUT was pre-tested under the following modes:

Test Mode	Description
Mode A	Power from Adapter mode (USB Cable Type A to Type C cable)
Mode B	Power from Adapter mode (USB Cable Type C to Type C Cable)
Mode C	Power from Battery

Note: From the above modes, the worst case was found in **Mode A**. Therefore only the test data of the mode was recorded in this report.

8. For conducted emissions, the EUT was pre-tested under the following modes:

Test Mode	Description
Mode A	Power from Adapter mode (USB Cable Type A to Type C cable)
Mode B	Power from Adapter mode (USB Cable Type C to Type C Cable)
Mode C	Power from Laptop mode (USB Cable Type to Type C cable)

Note: From the above modes, the worst case was found in **Mode A**. Therefore only the test data of the mode was recorded in this report.

9. The above EUT information is declared by manufacturer and for more detailed features description, please refer to the manufacturer's specifications or user's manual.

10. The above Antenna information is declared by manufacturer and for more detailed features description, please refer to the manufacturer's specifications, the laboratory shall not be held responsible.

3.2 Description of Test Modes

BT-LE function & logi bolt function channels:

RF Channel	RF Center Frequency	Channel Index	Channels Type for BT 5.x		Channels Type for BT 4.x
			Maximum Data Rate 2Mbps	Maximum Data Rate 1Mbps	Maximum Data Rate 1Mbps
0	2402 MHz	37		●	●
1	2404 MHz	0	●		●
2	2406 MHz	1	●		●
3	2408 MHz	2	●		●
4	2410 MHz	3	●		●
5	2412 MHz	4	●		●
6	2414 MHz	5	●		●
7	2416 MHz	6	●		●
8	2418 MHz	7	●		●
9	2420 MHz	8	●		●
10	2422 MHz	9	●		●
11	2424 MHz	10	●		●
12	2426 MHz	38		●	●
13	2428 MHz	11	●		●
14	2430 MHz	12	●		●
15	2432 MHz	13	●		●
16	2434 MHz	14	●		●
17	2436 MHz	15	●		●
18	2438 MHz	16	●		●
19	2440 MHz	17	●		●
20	2442 MHz	18	●		●
21	2444 MHz	19	●		●
22	2446 MHz	20	●		●
23	2448 MHz	21	●		●
24	2450 MHz	22	●		●
25	2452 MHz	23	●		●
26	2454 MHz	24	●		●
27	2456 MHz	25	●		●
28	2458 MHz	26	●		●
29	2460 MHz	27	●		●
30	2462 MHz	28	●		●
31	2464 MHz	29	●		●
32	2466 MHz	30	●		●
33	2468 MHz	31	●		●
34	2470 MHz	32	●		●
35	2472 MHz	33	●		●
36	2474 MHz	34	●		●
37	2476 MHz	35	●		●
38	2478 MHz	36	●		●
39	2480 MHz	39		●	●

3.2.1 Test Mode Applicability and Tested Channel Detail

EUT CONFIGURE MODE	APPLICABLE TO				DESCRIPTION
	RE \geq 1G	RE $<$ 1G	PLC	APCM	
-	√	√	√	√	-

Where **RE \geq 1G**: Radiated Emission above 1GHz & Bandedge Measurement
RE $<$ 1G: Radiated Emission below 1GHz
PLC: Power Line Conducted Emission
APCM: Antenna Port Conducted Measurement

Radiated Emission Test (Above 1GHz):

- Pre-Scan has been conducted to determine the worst-case mode from all possible combinations between available modulations, data rates and antenna ports (if EUT with antenna diversity architecture).
- Following channel(s) was (were) selected for the final test as listed below.

AVAILABLE CHANNEL	TESTED CHANNEL	MODULATION TYPE	DATA RATE (Mbps)
0 to 39	0, 19, 39	GFSK	1
1 to 38	1, 19, 38	GFSK	2

Radiated Emission Test (Below 1GHz):

- Pre-Scan has been conducted to determine the worst-case mode from all possible combinations between available modulations, data rates and antenna ports (if EUT with antenna diversity architecture).
- Following channel(s) was (were) selected for the final test as listed below.

AVAILABLE CHANNEL	TESTED CHANNEL	MODULATION TYPE	DATA RATE (Mbps)
0 to 39	0	GFSK	1

Power Line Conducted Emission Test:

- Pre-Scan has been conducted to determine the worst-case mode from all possible combinations between available modulations, data rates and antenna ports (if EUT with antenna diversity architecture).
- Following channel(s) was (were) selected for the final test as listed below.

AVAILABLE CHANNEL	TESTED CHANNEL	MODULATION TYPE	DATA RATE (Mbps)
0 to 39	0	GFSK	1

Antenna Port Conducted Measurement:

- This item includes all test value of each mode, but only includes spectrum plot of worst value of each mode.
- Pre-Scan has been conducted to determine the worst-case mode from all possible combinations between available modulations, data rates and antenna ports (if EUT with antenna diversity architecture).
- Following channel(s) was (were) selected for the final test as listed below.

AVAILABLE CHANNEL	TESTED CHANNEL	MODULATION TYPE	DATA RATE (Mbps)
0 to 39	0, 19, 39	GFSK	1
1 to 38	1, 19, 38	GFSK	2

Test Condition:

Applicable to	Environmental Conditions	Input Power (System)	Tested By
RE \geq 1G	20deg. C, 70%RH	120Vac, 60Hz	Ryan Du
RE<1G	20deg. C, 70%RH	120Vac, 60Hz	Ryan Du
PLC	25deg. C, 75%RH	120Vac, 60Hz	Ryan Du
APCM	25deg. C, 60%RH	120Vac, 60Hz	Kevin Ko

3.3 Duty Cycle of Test Signal

BT-LE 1M

Duty cycle = 0.348 ms/7.106 ms = 0.049

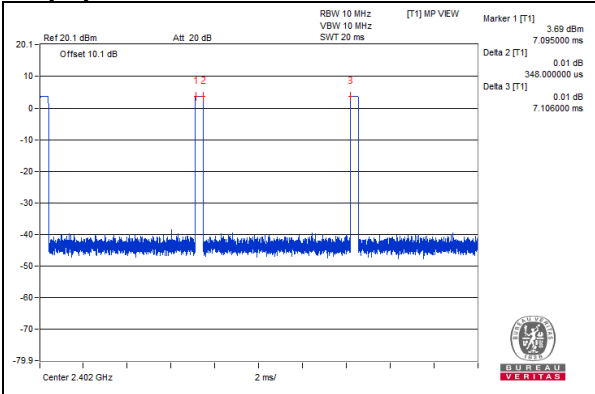

Note: For BT-LE function & Logi bolt function mode, this is highest operational duty cycle.

BT-LE 2M

Duty cycle = 0.18 ms/7.055 ms = 0.026

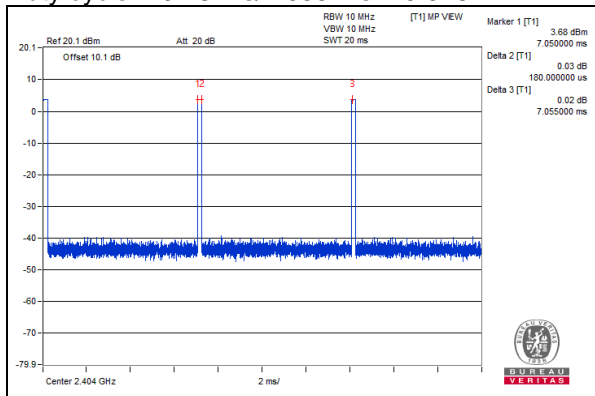

Note: For BT-LE function & Logi bolt function mode, this is highest operational duty cycle.

3.4 Description of Support Units

The EUT has been tested as an independent unit together with other necessary accessories or support units. The following support units or accessories were used to form a representative test configuration during the tests.

ID	Product	Brand	Model No.	Serial No	FCC ID	Remarks
A.	Adapter	ASUS	EXA1205UA	NA	NA	Provided by Lab

ID	Descriptions	Qty.	Length (m)	Shielding (Yes/No)	Cores (Qty.)	Remarks
1.	USB Cable Type A to Type C cable	1	1	Yes	0	Supplied by client

3.4.1 Configuration of System under Test

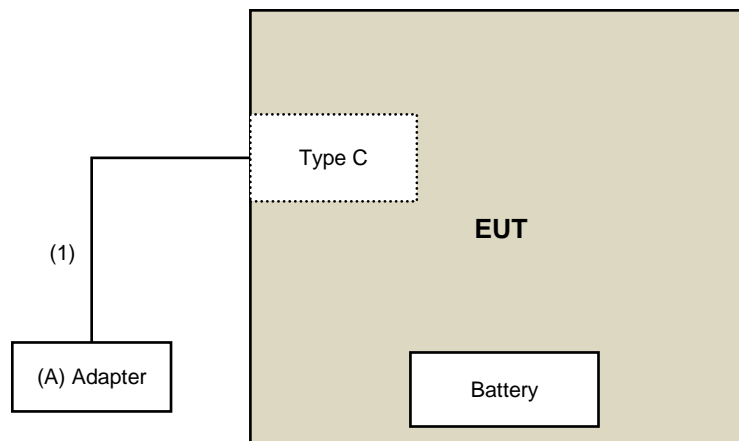

3.5 General Description of Applied Standards and References

The EUT is a RF Product. According to the specifications of the manufacturer, it must comply with the requirements of the following standards and references:

Test Standard:

FCC Part 15, Subpart C (15.247)

ANSI C63.10-2013

All test items have been performed and recorded as per the above standards.

References Test Guidance:

KDB 558074 D01 15.247 Meas Guidance v05r02

All test items have been performed as a reference to the above KDB test guidance.

4 Test Types and Results

4.1 Radiated Emission and Bandedge Measurement

4.1.1 Limits of Radiated Emission and Bandedge Measurement

Radiated emissions which fall in the restricted bands must comply with the radiated emission limits specified as below table. Other emissions shall be at least 20dB below the highest level of the desired power:

Frequencies (MHz)	Field Strength (microvolts/meter)	Measurement Distance (meters)
0.009 ~ 0.490	2400/F(kHz)	300
0.490 ~ 1.705	24000/F(kHz)	30
1.705 ~ 30.0	30	30
30 ~ 88	100	3
88 ~ 216	150	3
216 ~ 960	200	3
Above 960	500	3

Note:

1. The lower limit shall apply at the transition frequencies.
2. Emission level (dBuV/m) = 20 log Emission level (uV/m).
3. For frequencies above 1000MHz, the field strength limits are based on average detector, however, the peak field strength of any emission shall not exceed the maximum permitted average limits, specified above by more than 20dB under any condition of modulation.

4.1.2 Test Instruments

For Radiated Emission (above 1GHz) & Band Edge test:

DESCRIPTION & MANUFACTURER	MODEL NO.	SERIAL NO.	CALIBRATED DATE	CALIBRATED UNTIL
Test Receiver Keysight	N9038A	MY54450088	July 06, 2020	July 05, 2021
Horn_Antenna SCHWARZBECK	BBHA9120-D	9120D-406	Nov. 22, 2020	Nov. 21, 2021
Pre-Amplifier EMCI	EMC12630SE	980384	Jan. 11, 2021	Jan. 10, 2022
RF Cable	EMC104-SM-SM-1500	180504	Apr. 26, 2021	Apr. 25, 2022
RF Cable	EMC104-SM-SM-2000	180601	June 09, 2020	June 08, 2021
RF Cable	EMC104-SM-SM-6000	210201	Mar. 16, 2021	Mar. 15, 2022
Spectrum Analyzer Keysight	N9030A	MY54490679	July 13, 2020	July 12, 2021
Pre-Amplifier EMCI	EMC184045SE	980387	Jan. 11, 2021	Jan. 10, 2022
Horn_Antenna SCHWARZBECK	BBHA 9170	BBHA9170519	Nov. 22, 2020	Nov. 21, 2021
RF Cable	EMC102-KM-KM-1200	160924	Jan. 11, 2021	Jan. 10, 2022
RF Cable	EMC-KM-KM-4000	200214	Mar. 10, 2021	Mar. 09, 2022
Software	ADT_Radiated_V8.7.08	NA	NA	NA
Antenna Tower & Turn Table Max-Full	MF-7802	MF780208406	NA	NA
Boresight Antenna Fixture	FBA-01	FBA-SIP01	NA	NA

Note:

1. The calibration interval of the above test instruments is 12 months and the calibrations are traceable to NML/ROC and NIST/USA.
2. The test was performed in 966 Chamber No. 3.
3. Tested Date: May 18 to 19, 2021

For Radiated Emission (below 1GHz) test:

DESCRIPTION & MANUFACTURER	MODEL NO.	SERIAL NO.	CALIBRATED DATE	CALIBRATED UNTIL
Test Receiver Keysight	N9038A	MY54450088	July 06, 2020	July 05, 2021
Pre-Amplifier EMCI	EMC001340	980142	May 24, 2021	May 23, 2022
Loop Antenna Electro-Metrics	EM-6879	264	Mar. 05, 2021	Mar. 04, 2022
RF Cable	5D-FB	LOOPCAB-001	Jan. 07, 2021	Jan. 06, 2022
RF Cable	5D-FB	LOOPCAB-002	Jan. 07, 2021	Jan. 06, 2022
Pre-Amplifier Mini-Circuits	ZFL-1000VH2	QA0838008	Oct. 20, 2020	Oct. 19, 2021
Trilog Broadband Antenna SCHWARZBECK	VULB 9168	9168-361	Nov. 05, 2020	Nov. 04, 2021
RF Cable	8D	966-3-1	Mar. 16, 2021	Mar. 15, 2022
RF Cable	8D	966-3-2	Mar. 16, 2021	Mar. 15, 2022
RF Cable	8D	966-3-3	Mar. 16, 2021	Mar. 15, 2022
Fixed attenuator Mini-Circuits	UNAT-5+	PAD-3m-3-01	Sep. 24, 2020	Sep. 23, 2021
Software	ADT_Radiated_V8.7.08	NA	NA	NA
Antenna Tower & Turn Table Max-Full	MF-7802	MF780208406	NA	NA

Note:

1. The calibration interval of the above test instruments is 12 months and the calibrations are traceable to NML/ROC and NIST/USA.
2. The test was performed in 966 Chamber No. 3.
3. Tested Date: May 24, 2021

For other test items:

DESCRIPTION & MANUFACTURER	MODEL NO.	SERIAL NO.	CALIBRATED DATE	CALIBRATED UNTIL
Spectrum Analyzer R&S	FSV40	100964	May 29, 2020	May 28, 2021
Power meter Anritsu	ML2495A	1529002	July 22, 2020	July 21, 2021
Power sensor Anritsu	MA2411B	1339443	July 22, 2020	July 21, 2021
Fixed Attenuator Mini-Circuits	MDCS18N-10	MDCS18N-10-01	Apr. 13, 2021	Apr. 12, 2022
Software	ADT_RF Test Software V6.6.5.4	NA	NA	NA

- NOTE:**
1. The test was performed in Oven room 2.
 2. The calibration interval of the above test instruments is 12 months and the calibrations are traceable to NML/ROC and NIST/USA.
 3. Tested Date: May 19, 2021

4.1.3 Test Procedures

For Radiated emission below 30MHz

- a. The EUT was placed on the top of a rotating table 0.8 meters above the ground at a 3 meter chamber room. The table was rotated 360 degrees to determine the position of the highest radiation.
- b. The EUT was set 3 meters away from the interference-receiving antenna, which was mounted on the top of a variable-height antenna tower.
- c. Parallel, perpendicular, and ground-parallel orientations of the antenna are set to make the measurement.
- d. For each suspected emission, the EUT was arranged to its worst case and the rotatable table was turned from 0 degrees to 360 degrees to find the maximum reading.
- e. The test-receiver system was set to Quasi-Peak Detect Function and Specified Bandwidth with Maximum Hold Mode.

Note:

1. The resolution bandwidth and video bandwidth of test receiver/spectrum analyzer is 9kHz at frequency below 30MHz.

For Radiated emission above 30MHz

- a. The EUT was placed on the top of a rotating table 0.8 meters (for 30MHz ~ 1GHz) / 1.5 meters (for above 1GHz) above the ground at 3 meter chamber room for test. The table was rotated 360 degrees to determine the position of the highest radiation.
- b. The EUT was set 3 meters away from the interference-receiving antenna, which was mounted on the top of a variable-height antenna tower.
- c. The height of antenna is varied from one meter to four meters above the ground to determine the maximum value of the field strength. Both horizontal and vertical polarizations of the antenna are set to make the measurement.
- d. For each suspected emission, the EUT was arranged to its worst case and then the antenna was tuned to heights from 1 meter to 4 meters and the rotatable table was turned from 0 degrees to 360 degrees to find the maximum reading.
- e. The test-receiver system was set to quasi-peak detect function and specified bandwidth with maximum hold mode when the test frequency is below 1 GHz.
- f. The test-receiver system was set to peak and average detects function and specified bandwidth with maximum hold mode when the test frequency is above 1 GHz. If the peak reading value also meets average limit, measurement with the average detector is unnecessary.

Note:

1. The resolution bandwidth and video bandwidth of test receiver/spectrum analyzer is 120kHz for Quasi-peak detection (QP) at frequency below 1GHz.
2. The resolution bandwidth of test receiver/spectrum analyzer is 1 MHz and the video bandwidth is 3 MHz for Peak detection (PK) at frequency above 1GHz.
3. The resolution bandwidth of test receiver/spectrum analyzer is 1 MHz and the video bandwidth is 3 MHz for Average detection (AV) at frequency above 1GHz.
4. All modes of operation were investigated and the worst-case emissions are reported.

4.1.4 Deviation from Test Standard

No deviation.

4.1.5 Test Setup

For Radiated emission below 30MHz

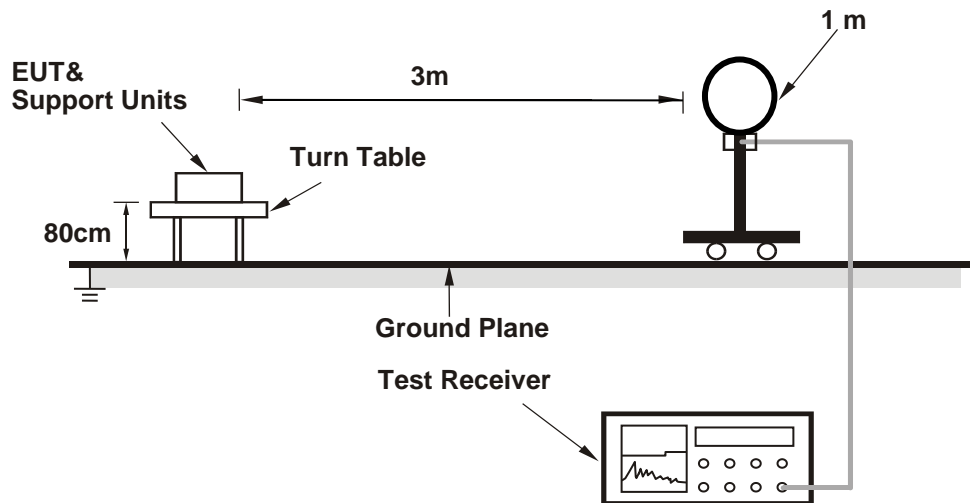

For Radiated emission 30MHz to 1GHz

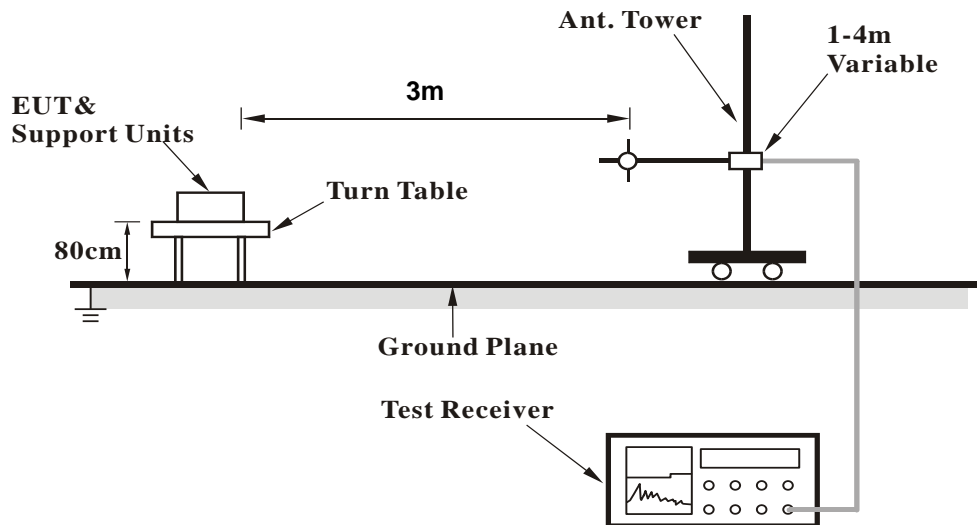

For Radiated emission above 1GHz

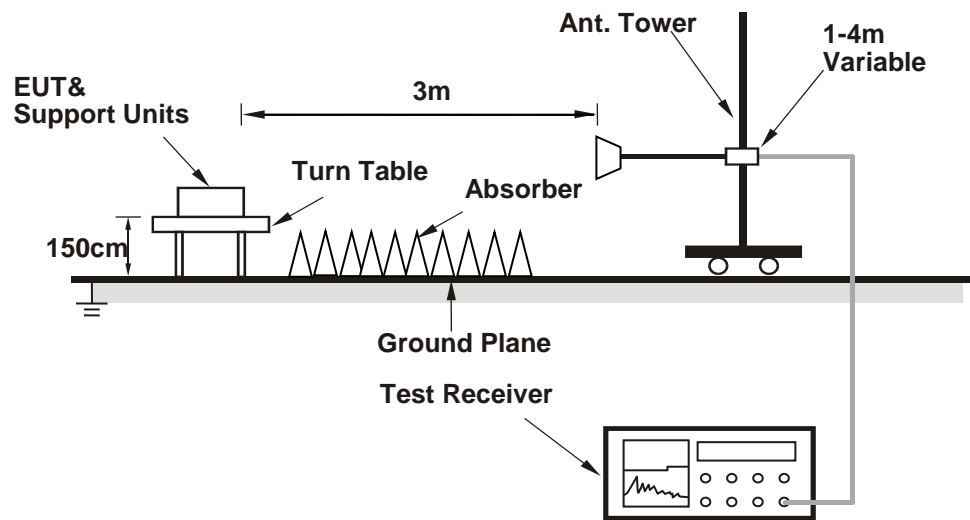

For the actual test configuration, please refer to the attached file (Test Setup Photo).

4.1.6 EUT Operating Conditions

- a. Placed the EUT on the testing table.
- b. Controlling software (RF Sample with Receiver [Number Lock]) has been activated to set the EUT under transmission condition continuously at specific channel frequency.
 - ◆ BLE1M TX Modulated low duty cycle on channel 2402MHz
 - ◆ BLE1M TX Modulated low duty cycle on channel 2440MHz
 - ◆ BLE1M TX Modulated low duty cycle on channel 2480MHz
 - ◆ BLE2M TX Modulated low duty cycle on channel 2404MHz
 - ◆ BLE2M TX Modulated low duty cycle on channel 2440MHz
 - ◆ BLE2M TX Modulated low duty cycle on channel 2478MHz

4.1.7 Test Results

BT-LE function
Above 1GHz Data:
BT-LE 1M

RF Mode	TX BT_LE-1M	Channel	CH 0 : 2402 MHz
Frequency Range	1GHz ~ 25GHz	Detector Function	Peak (PK) Average (AV)

Antenna Polarity & Test Distance : Horizontal at 3 m

No	Frequency (MHz)	Emission Level (dBuV/m)	Limit (dBuV/m)	Margin (dB)	Antenna Height (m)	Table Angle (Degree)	Raw Value (dBuV)	Correction Factor (dB/m)
1	2315.71	58.0 PK	74.0	-16.0	1.01 H	241	59.0	-1.0
2	2315.71	49.0 AV	54.0	-5.0	1.01 H	241	50.0	-1.0
3	2390.00	59.0 PK	74.0	-15.0	1.01 H	241	60.2	-1.2
4	2390.00	44.9 AV	54.0	-9.1	1.01 H	241	46.1	-1.2
5	*2402.00	101.3 PK			1.01 H	241	102.5	-1.2
6	*2402.00	75.1 AV			1.01 H	241	76.3	-1.2
7	2488.35	57.7 PK	74.0	-16.3	1.01 H	241	58.8	-1.1
8	2488.35	49.4 AV	54.0	-4.6	1.01 H	241	50.5	-1.1
9	4804.00	45.5 PK	74.0	-28.5	1.18 H	247	41.8	3.7
10	4804.00	19.3 AV	54.0	-34.7	1.18 H	247	15.6	3.7

Antenna Polarity & Test Distance : Vertical at 3 m

No	Frequency (MHz)	Emission Level (dBuV/m)	Limit (dBuV/m)	Margin (dB)	Antenna Height (m)	Table Angle (Degree)	Raw Value (dBuV)	Correction Factor (dB/m)
1	2390.00	57.3 PK	74.0	-16.7	3.68 V	291	58.5	-1.2
2	2390.00	44.9 AV	54.0	-9.1	3.68 V	291	46.1	-1.2
3	*2402.00	96.5 PK			3.68 V	291	97.7	-1.2
4	*2402.00	70.3 AV			3.68 V	291	71.5	-1.2
5	4804.00	45.6 PK	74.0	-28.4	1.33 V	56	41.9	3.7
6	4804.00	19.4 AV	54.0	-34.6	1.33 V	56	15.7	3.7

Remarks:

1. Emission Level(dBuV/m) = Raw Value(dBuV) + Correction Factor(dB/m)
2. Correction Factor(dB/m) = Antenna Factor(dB/m) + Cable Factor(dB) – Pre-Amplifier Factor(dB)
3. Margin value = Emission Level – Limit value
4. The other emission levels were very low against the limit.
5. " * ": Fundamental frequency.
6. The average value of fundamental and harmonic frequency is: Average = Peak value + 20 log(Duty cycle) Where the duty factor is calculated from following formula:
 $20 \log(\text{Duty cycle}) = 20 \log(0.348 \text{ ms} / 7.106 \text{ ms}) = -26.2 \text{ dB}$
 Please see page 3.3 for plotted duty.

RF Mode	TX BT_LE-1M	Channel	CH 19 : 2440 MHz
Frequency Range	1GHz ~ 25GHz	Detector Function	Peak (PK) Average (AV)

Antenna Polarity & Test Distance : Horizontal at 3 m

No	Frequency (MHz)	Emission Level (dBuV/m)	Limit (dBuV/m)	Margin (dB)	Antenna Height (m)	Table Angle (Degree)	Raw Value (dBuV)	Correction Factor (dB/m)
1	*2440.00	100.6 PK			1.06 H	243	101.8	-1.2
2	*2440.00	74.4 AV			1.06 H	243	75.6	-1.2
3	4880.00	45.3 PK	74.0	-28.7	1.24 H	253	41.5	3.8
4	4880.00	19.1 AV	54.0	-34.9	1.24 H	253	15.3	3.8
5	7320.00	49.5 PK	74.0	-24.5	1.14 H	265	39.9	9.6
6	7320.00	23.3 AV	54.0	-30.7	1.14 H	265	13.7	9.6

Antenna Polarity & Test Distance : Vertical at 3 m

No	Frequency (MHz)	Emission Level (dBuV/m)	Limit (dBuV/m)	Margin (dB)	Antenna Height (m)	Table Angle (Degree)	Raw Value (dBuV)	Correction Factor (dB/m)
1	*2440.00	96.7 PK			3.77 V	289	97.9	-1.2
2	*2440.00	70.5 AV			3.77 V	289	71.7	-1.2
3	4880.00	45.9 PK	74.0	-28.1	1.28 V	42	42.1	3.8
4	4880.00	19.7 AV	54.0	-34.3	1.28 V	42	15.9	3.8
5	7320.00	52.2 PK	74.0	-21.8	1.14 V	269	42.6	9.6
6	7320.00	26.0 AV	54.0	-28.0	1.14 V	269	16.4	9.6

Remarks:

- Emission Level(dBuV/m) = Raw Value(dBuV) + Correction Factor(dB/m)
- Correction Factor(dB/m) = Antenna Factor(dB/m) + Cable Factor(dB) – Pre-Amplifier Factor(dB)
- Margin value = Emission Level – Limit value
- The other emission levels were very low against the limit.
- " * ": Fundamental frequency.
- The average value of fundamental and harmonic frequency is: Average = Peak value + 20 log(Duty cycle) Where the duty factor is calculated from following formula:
 $20 \log(\text{Duty cycle}) = 20 \log(0.348 \text{ ms} / 7.106 \text{ ms}) = -26.2 \text{ dB}$
 Please see page 3.3 for plotted duty.

RF Mode	TX BT_LE-1M	Channel	CH 39 : 2480 MHz
Frequency Range	1GHz ~ 25GHz	Detector Function	Peak (PK) Average (AV)

Antenna Polarity & Test Distance : Horizontal at 3 m								
No	Frequency (MHz)	Emission Level (dBuV/m)	Limit (dBuV/m)	Margin (dB)	Antenna Height (m)	Table Angle (Degree)	Raw Value (dBuV)	Correction Factor (dB/m)
1	*2480.00	100.0 PK			1.04 H	244	101.1	-1.1
2	*2480.00	73.8 AV			1.04 H	244	74.9	-1.1
3	2483.50	65.6 PK	74.0	-8.4	1.04 H	244	66.7	-1.1
4	2483.50	39.4 AV	54.0	-14.6	1.04 H	244	40.5	-1.1
5	4960.00	45.2 PK	74.0	-28.8	1.21 H	259	41.2	4.0
6	4960.00	19.0 AV	54.0	-35.0	1.21 H	259	15.0	4.0
7	7440.00	49.3 PK	74.0	-24.7	1.13 H	257	39.6	9.7
8	7440.00	23.1 AV	54.0	-30.9	1.13 H	257	13.4	9.7

Antenna Polarity & Test Distance : Vertical at 3 m								
No	Frequency (MHz)	Emission Level (dBuV/m)	Limit (dBuV/m)	Margin (dB)	Antenna Height (m)	Table Angle (Degree)	Raw Value (dBuV)	Correction Factor (dB/m)
1	*2480.00	96.6 PK			3.96 V	295	97.7	-1.1
2	*2480.00	70.4 AV			3.96 V	295	71.5	-1.1
3	2483.50	60.6 PK	74.0	-13.4	3.96 V	295	61.7	-1.1
4	2483.50	34.4 AV	54.0	-19.6	3.96 V	295	35.5	-1.1
5	4960.00	45.7 PK	74.0	-28.3	1.28 V	54	41.7	4.0
6	4960.00	19.5 AV	54.0	-34.5	1.28 V	54	15.5	4.0
7	7440.00	51.9 PK	74.0	-22.1	1.11 V	272	42.2	9.7
8	7440.00	25.7 AV	54.0	-28.3	1.11 V	272	16.0	9.7

Remarks:

1. Emission Level(dBuV/m) = Raw Value(dBuV) + Correction Factor(dB/m)
2. Correction Factor(dB/m) = Antenna Factor(dB/m) + Cable Factor(dB) – Pre-Amplifier Factor(dB)
3. Margin value = Emission Level – Limit value
4. The other emission levels were very low against the limit.
5. " * ": Fundamental frequency.
6. The average value of fundamental and harmonic frequency is: Average = Peak value + 20 log(Duty cycle) Where the duty factor is calculated from following formula:
 $20 \log(\text{Duty cycle}) = 20 \log(0.348 \text{ ms} / 7.106 \text{ ms}) = -26.2 \text{ dB}$
Please see page 3.3 for plotted duty.

BT-LE 2M

RF Mode	TX BT_LE-2M	Channel	CH 1 : 2404 MHz
Frequency Range	1GHz ~ 25GHz	Detector Function	Peak (PK) Average (AV)

Antenna Polarity & Test Distance : Horizontal at 3 m								
No	Frequency (MHz)	Emission Level (dBuV/m)	Limit (dBuV/m)	Margin (dB)	Antenna Height (m)	Table Angle (Degree)	Raw Value (dBuV)	Correction Factor (dB/m)
1	2320.59	57.5 PK	74.0	-16.5	1.01 H	239	58.5	-1.0
2	2320.59	48.9 AV	54.0	-5.1	1.01 H	239	49.9	-1.0
3	2390.00	58.4 PK	74.0	-15.6	1.01 H	239	59.6	-1.2
4	2390.00	46.1 AV	54.0	-7.9	1.01 H	239	47.3	-1.2
5	*2404.00	101.5 PK			1.01 H	239	102.7	-1.2
6	*2404.00	69.6 AV			1.01 H	239	70.8	-1.2
7	2490.65	57.4 PK	74.0	-16.6	1.01 H	239	58.5	-1.1
8	2490.65	49.4 AV	54.0	-4.6	1.01 H	239	50.5	-1.1
9	4808.00	45.6 PK	74.0	-28.4	1.19 H	278	41.9	3.7
10	4808.00	13.7 AV	54.0	-40.3	1.19 H	278	10.0	3.7

Antenna Polarity & Test Distance : Vertical at 3 m								
No	Frequency (MHz)	Emission Level (dBuV/m)	Limit (dBuV/m)	Margin (dB)	Antenna Height (m)	Table Angle (Degree)	Raw Value (dBuV)	Correction Factor (dB/m)
1	2390.00	57.4 PK	74.0	-16.6	3.76 V	292	58.6	-1.2
2	2390.00	44.3 AV	54.0	-9.7	3.76 V	292	45.5	-1.2
3	*2404.00	97.6 PK			3.76 V	292	98.8	-1.2
4	*2404.00	65.7 AV			3.76 V	292	66.9	-1.2
5	4808.00	45.5 PK	74.0	-28.5	1.34 V	56	41.8	3.7
6	4808.00	13.6 AV	54.0	-40.4	1.34 V	56	9.9	3.7

Remarks:

- Emission Level(dBuV/m) = Raw Value(dBuV) + Correction Factor(dB/m)
- Correction Factor(dB/m) = Antenna Factor(dB/m) + Cable Factor(dB) – Pre-Amplifier Factor(dB)
- Margin value = Emission Level – Limit value
- The other emission levels were very low against the limit.
- " * ": Fundamental frequency.
- The average value of fundamental and harmonic frequency is: Average = Peak value + 20 log(Duty cycle) Where the duty factor is calculated from following formula:
 $20 \log(\text{Duty cycle}) = 20 \log(0.18 \text{ ms} / 7.055 \text{ ms}) = -31.9 \text{ dB}$
 Please see page 3.3 for plotted duty.

RF Mode	TX BT_LE-2M	Channel	CH 19 : 2440 MHz
Frequency Range	1GHz ~ 25GHz	Detector Function	Peak (PK) Average (AV)

Antenna Polarity & Test Distance : Horizontal at 3 m								
No	Frequency (MHz)	Emission Level (dBuV/m)	Limit (dBuV/m)	Margin (dB)	Antenna Height (m)	Table Angle (Degree)	Raw Value (dBuV)	Correction Factor (dB/m)
1	*2440.00	101.2 PK			1.09 H	253	102.4	-1.2
2	*2440.00	69.3 AV			1.09 H	253	70.5	-1.2
3	4880.00	45.8 PK	74.0	-28.2	1.22 H	262	42.0	3.8
4	4880.00	13.9 AV	54.0	-40.1	1.22 H	262	10.1	3.8
5	7320.00	49.4 PK	74.0	-24.6	1.14 H	247	39.8	9.6
6	7320.00	17.5 AV	54.0	-36.5	1.14 H	247	7.9	9.6

Antenna Polarity & Test Distance : Vertical at 3 m								
No	Frequency (MHz)	Emission Level (dBuV/m)	Limit (dBuV/m)	Margin (dB)	Antenna Height (m)	Table Angle (Degree)	Raw Value (dBuV)	Correction Factor (dB/m)
1	*2440.00	97.4 PK			3.78 V	298	98.6	-1.2
2	*2440.00	65.5 AV			3.78 V	298	66.7	-1.2
3	4880.00	45.6 PK	74.0	-28.4	1.31 V	57	41.8	3.8
4	4880.00	13.7 AV	54.0	-40.3	1.31 V	57	9.9	3.8
5	7320.00	51.7 PK	74.0	-22.3	1.09 V	286	42.1	9.6
6	7320.00	19.8 AV	54.0	-34.2	1.09 V	286	10.2	9.6

Remarks:

- Emission Level(dBuV/m) = Raw Value(dBuV) + Correction Factor(dB/m)
- Correction Factor(dB/m) = Antenna Factor(dB/m) + Cable Factor(dB) – Pre-Amplifier Factor(dB)
- Margin value = Emission Level – Limit value
- The other emission levels were very low against the limit.
- " * ": Fundamental frequency.
- The average value of fundamental and harmonic frequency is: Average = Peak value + 20 log(Duty cycle) Where the duty factor is calculated from following formula:
 $20 \log(\text{Duty cycle}) = 20 \log(0.18 \text{ ms} / 7.055 \text{ ms}) = -31.9 \text{ dB}$
Please see page 3.3 for plotted duty.

RF Mode	TX BT_LE-2M	Channel	CH 38 : 2478 MHz
Frequency Range	1GHz ~ 25GHz	Detector Function	Peak (PK) Average (AV)

Antenna Polarity & Test Distance : Horizontal at 3 m								
No	Frequency (MHz)	Emission Level (dBuV/m)	Limit (dBuV/m)	Margin (dB)	Antenna Height (m)	Table Angle (Degree)	Raw Value (dBuV)	Correction Factor (dB/m)
1	*2478.00	100.4 PK			1.27 H	240	101.5	-1.1
2	*2478.00	68.5 AV			1.27 H	240	69.6	-1.1
3	2483.50	62.6 PK	74.0	-11.4	1.27 H	240	63.7	-1.1
4	2483.50	30.7 AV	54.0	-23.3	1.27 H	240	31.8	-1.1
5	4956.00	45.7 PK	74.0	-28.3	1.22 H	269	41.7	4.0
6	4956.00	13.8 AV	54.0	-40.2	1.22 H	269	9.8	4.0
7	7434.00	49.5 PK	74.0	-24.5	1.13 H	247	39.8	9.7
8	7434.00	17.6 AV	54.0	-36.4	1.13 H	247	7.9	9.7

Antenna Polarity & Test Distance : Vertical at 3 m								
No	Frequency (MHz)	Emission Level (dBuV/m)	Limit (dBuV/m)	Margin (dB)	Antenna Height (m)	Table Angle (Degree)	Raw Value (dBuV)	Correction Factor (dB/m)
1	*2478.00	96.7 PK			3.98 V	291	97.8	-1.1
2	*2478.00	64.8 AV			3.98 V	291	65.9	-1.1
3	2483.50	60.7 PK	74.0	-13.3	3.98 V	291	61.8	-1.1
4	2483.50	28.8 AV	54.0	-25.2	3.98 V	291	29.9	-1.1
5	4956.00	45.6 PK	74.0	-28.4	1.28 V	51	41.6	4.0
6	4956.00	13.7 AV	54.0	-40.3	1.28 V	51	9.7	4.0
7	7434.00	51.5 PK	74.0	-22.5	1.07 V	272	41.8	9.7
8	7434.00	19.6 AV	54.0	-34.4	1.07 V	272	9.9	9.7

Remarks:

1. Emission Level(dBuV/m) = Raw Value(dBuV) + Correction Factor(dB/m)
2. Correction Factor(dB/m) = Antenna Factor(dB/m) + Cable Factor(dB) – Pre-Amplifier Factor(dB)
3. Margin value = Emission Level – Limit value
4. The other emission levels were very low against the limit.
5. " * ": Fundamental frequency.
6. The average value of fundamental and harmonic frequency is: Average = Peak value + 20 log(Duty cycle) Where the duty factor is calculated from following formula:
 $20 \log(\text{Duty cycle}) = 20 \log(0.18 \text{ ms} / 7.055 \text{ ms}) = -31.9 \text{ dB}$
Please see page 3.3 for plotted duty.

Below 1GHz Data:

RF Mode	TX BT_LE-1M	Channel	CH 0 : 2402 MHz
Frequency Range	9kHz ~ 1GHz	Detector Function	Quasi-Peak (QP)

Antenna Polarity & Test Distance : Horizontal at 3 m								
No	Frequency (MHz)	Emission Level (dBuV/m)	Limit (dBuV/m)	Margin (dB)	Antenna Height (m)	Table Angle (Degree)	Raw Value (dBuV)	Correction Factor (dB/m)
1	40.89	23.9 QP	40.0	-16.1	2.00 H	253	32.3	-8.4
2	63.42	21.3 QP	40.0	-18.7	2.50 H	248	30.4	-9.1
3	135.22	22.4 QP	43.5	-21.1	1.50 H	270	30.8	-8.4
4	197.13	22.0 QP	43.5	-21.5	1.00 H	258	32.6	-10.6
5	308.39	22.2 QP	46.0	-23.8	2.00 H	231	28.4	-6.2
6	439.63	27.1 QP	46.0	-18.9	1.50 H	355	29.3	-2.2

Remarks:

1. Emission Level(dBuV/m) = Raw Value(dBuV) + Correction Factor(dB/m)
2. Correction Factor(dB/m) = Antenna Factor(dB/m) + Cable Factor(dB) – Pre-Amplifier Factor(dB)
3. Margin value = Emission Level – Limit value
4. The other emission levels were very low against the limit of frequency range 30MHz~1000MHz.
5. The emission levels were very low against the limit of frequency range 9kHz~30MHz: the amplitude of spurious emissions attenuated more than 20 dB below the permissible value to be report.

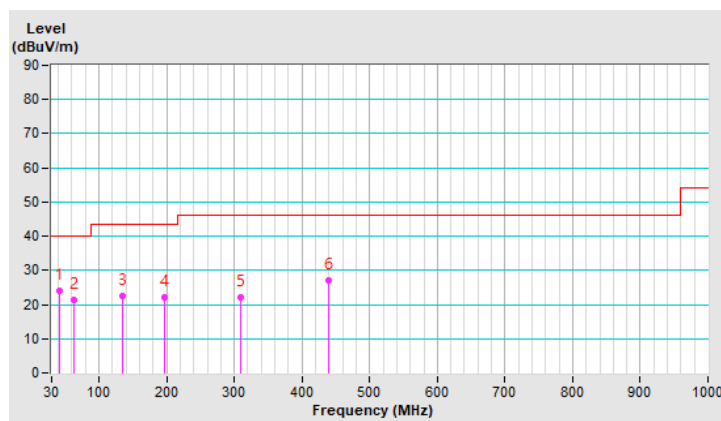

RF Mode	TX BT_LE-1M	Channel	CH 0 : 2402 MHz
Frequency Range	9kHz ~ 1GHz	Detector Function	Quasi-Peak (QP)

Antenna Polarity & Test Distance : Vertical at 3 m

No	Frequency (MHz)	Emission Level (dBuV/m)	Limit (dBuV/m)	Margin (dB)	Antenna Height (m)	Table Angle (Degree)	Raw Value (dBuV)	Correction Factor (dB/m)
1	41.35	33.2 QP	40.0	-6.8	1.00 V	125	41.6	-8.4
2	73.89	23.5 QP	40.0	-16.5	1.00 V	360	35.0	-11.5
3	87.84	23.0 QP	40.0	-17.0	1.00 V	0	36.9	-13.9
4	195.94	20.9 QP	43.5	-22.6	2.50 V	151	31.4	-10.5
5	229.07	21.7 QP	46.0	-24.3	2.00 V	335	31.8	-10.1
6	570.85	29.4 QP	46.0	-16.6	1.00 V	192	29.1	0.3

Remarks:

1. Emission Level(dBuV/m) = Raw Value(dBuV) + Correction Factor(dB/m)
2. Correction Factor(dB/m) = Antenna Factor(dB/m) + Cable Factor(dB) – Pre-Amplifier Factor(dB)
3. Margin value = Emission Level – Limit value
4. The other emission levels were very low against the limit of frequency range 30MHz~1000MHz.
5. The emission levels were very low against the limit of frequency range 9kHz~30MHz: the amplitude of spurious emissions attenuated more than 20 dB below the permissible value to be report.

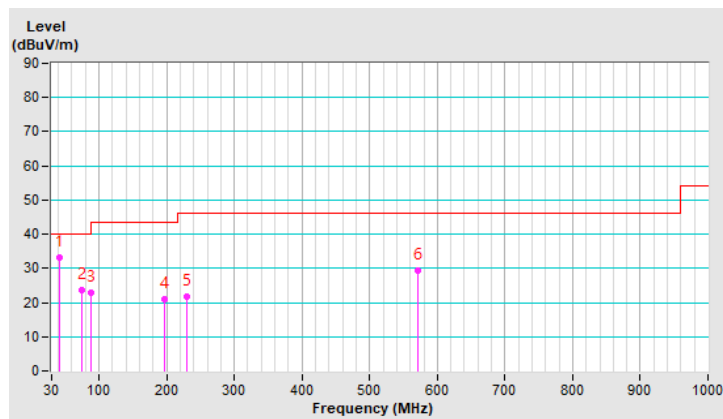

logi bolt function

Above 1GHz Data:

BT-LE 1M

RF Mode	TX BT_LE-1M	Channel	CH 0 : 2402 MHz
Frequency Range	1GHz ~ 25GHz	Detector Function	Peak (PK) Average (AV)

Antenna Polarity & Test Distance : Horizontal at 3 m

No	Frequency (MHz)	Emission Level (dBuV/m)	Limit (dBuV/m)	Margin (dB)	Antenna Height (m)	Table Angle (Degree)	Raw Value (dBuV)	Correction Factor (dB/m)
1	2315.53	57.6 PK	74.0	-16.4	1.02 H	243	58.6	-1.0
2	2315.53	49.0 AV	54.0	-5.0	1.02 H	243	50.0	-1.0
3	2390.00	59.2 PK	74.0	-14.8	1.02 H	243	60.4	-1.2
4	2390.00	44.6 AV	54.0	-9.4	1.02 H	243	45.8	-1.2
5	*2402.00	101.2 PK			1.02 H	243	102.4	-1.2
6	*2402.00	75.0 AV			1.02 H	243	76.2	-1.2
7	2485.29	58.1 PK	74.0	-15.9	1.02 H	243	59.2	-1.1
8	2485.29	49.3 AV	54.0	-4.7	1.02 H	243	50.4	-1.1
9	4804.00	45.2 PK	74.0	-28.8	1.12 H	256	41.5	3.7
10	4804.00	19.0 AV	54.0	-35.0	1.12 H	256	15.3	3.7

Antenna Polarity & Test Distance : Vertical at 3 m

No	Frequency (MHz)	Emission Level (dBuV/m)	Limit (dBuV/m)	Margin (dB)	Antenna Height (m)	Table Angle (Degree)	Raw Value (dBuV)	Correction Factor (dB/m)
1	2390.00	55.9 PK	74.0	-18.1	3.72 V	295	57.1	-1.2
2	2390.00	44.9 AV	54.0	-9.1	3.72 V	295	46.1	-1.2
3	*2402.00	96.8 PK			3.72 V	295	98.0	-1.2
4	*2402.00	70.6 AV			3.72 V	295	71.8	-1.2
5	4804.00	45.8 PK	74.0	-28.2	1.21 V	36	42.1	3.7
6	4804.00	19.6 AV	54.0	-34.4	1.21 V	36	15.9	3.7

Remarks:

- Emission Level(dBuV/m) = Raw Value(dBuV) + Correction Factor(dB/m)
- Correction Factor(dB/m) = Antenna Factor(dB/m) + Cable Factor(dB) – Pre-Amplifier Factor(dB)
- Margin value = Emission Level – Limit value
- The other emission levels were very low against the limit.
- " * ": Fundamental frequency.
- The average value of fundamental and harmonic frequency is: Average = Peak value + 20 log(Duty cycle) Where the duty factor is calculated from following formula:
 $20 \log(\text{Duty cycle}) = 20 \log(0.348 \text{ ms} / 7.106 \text{ ms}) = -26.2 \text{ dB}$
Please see page 3.3 for plotted duty.

RF Mode	TX BT_LE-1M	Channel	CH 19 : 2440 MHz
Frequency Range	1GHz ~ 25GHz	Detector Function	Peak (PK) Average (AV)

Antenna Polarity & Test Distance : Horizontal at 3 m

No	Frequency (MHz)	Emission Level (dBuV/m)	Limit (dBuV/m)	Margin (dB)	Antenna Height (m)	Table Angle (Degree)	Raw Value (dBuV)	Correction Factor (dB/m)
1	*2440.00	100.8 PK			1.04 H	242	102.0	-1.2
2	*2440.00	74.6 AV			1.04 H	242	75.8	-1.2
3	4880.00	45.3 PK	74.0	-28.7	1.24 H	260	41.5	3.8
4	4880.00	19.1 AV	54.0	-34.9	1.24 H	260	15.3	3.8
5	7320.00	49.4 PK	74.0	-24.6	1.08 H	257	39.8	9.6
6	7320.00	23.2 AV	54.0	-30.8	1.08 H	257	13.6	9.6

Antenna Polarity & Test Distance : Vertical at 3 m

No	Frequency (MHz)	Emission Level (dBuV/m)	Limit (dBuV/m)	Margin (dB)	Antenna Height (m)	Table Angle (Degree)	Raw Value (dBuV)	Correction Factor (dB/m)
1	*2440.00	97.0 PK			3.91 V	304	98.2	-1.2
2	*2440.00	70.8 AV			3.91 V	304	72.0	-1.2
3	4880.00	45.7 PK	74.0	-28.3	1.31 V	42	41.9	3.8
4	4880.00	19.5 AV	54.0	-34.5	1.31 V	42	15.7	3.8
5	7320.00	52.2 PK	74.0	-21.8	1.11 V	281	42.6	9.6
6	7320.00	26.0 AV	54.0	-28.0	1.11 V	281	16.4	9.6

Remarks:

- Emission Level(dBuV/m) = Raw Value(dBuV) + Correction Factor(dB/m)
- Correction Factor(dB/m) = Antenna Factor(dB/m) + Cable Factor(dB) – Pre-Amplifier Factor(dB)
- Margin value = Emission Level – Limit value
- The other emission levels were very low against the limit.
- " * ": Fundamental frequency.
- The average value of fundamental and harmonic frequency is: Average = Peak value + 20 log(Duty cycle) Where the duty factor is calculated from following formula:
 $20 \log(\text{Duty cycle}) = 20 \log(0.348 \text{ ms} / 7.106 \text{ ms}) = -26.2 \text{ dB}$
 Please see page 3.3 for plotted duty.

RF Mode	TX BT_LE-1M	Channel	CH 39 : 2480 MHz
Frequency Range	1GHz ~ 25GHz	Detector Function	Peak (PK) Average (AV)

Antenna Polarity & Test Distance : Horizontal at 3 m								
No	Frequency (MHz)	Emission Level (dBuV/m)	Limit (dBuV/m)	Margin (dB)	Antenna Height (m)	Table Angle (Degree)	Raw Value (dBuV)	Correction Factor (dB/m)
1	*2480.00	99.9 PK			1.06 H	247	101.0	-1.1
2	*2480.00	73.7 AV			1.06 H	247	74.8	-1.1
3	2483.50	65.5 PK	74.0	-8.5	1.06 H	247	66.6	-1.1
4	2483.50	39.3 AV	54.0	-14.7	1.06 H	247	40.4	-1.1
5	4960.00	45.1 PK	74.0	-28.9	1.16 H	245	41.1	4.0
6	4960.00	18.9 AV	54.0	-35.1	1.16 H	245	14.9	4.0
7	7440.00	49.2 PK	74.0	-24.8	1.18 H	244	39.5	9.7
8	7440.00	23.0 AV	54.0	-31.0	1.18 H	244	13.3	9.7
Antenna Polarity & Test Distance : Vertical at 3 m								
No	Frequency (MHz)	Emission Level (dBuV/m)	Limit (dBuV/m)	Margin (dB)	Antenna Height (m)	Table Angle (Degree)	Raw Value (dBuV)	Correction Factor (dB/m)
1	*2480.00	96.5 PK			3.92 V	299	97.6	-1.1
2	*2480.00	70.3 AV			3.92 V	299	71.4	-1.1
3	2483.50	63.2 PK	74.0	-10.8	3.92 V	299	64.3	-1.1
4	2483.50	37.0 AV	54.0	-17.0	3.92 V	299	38.1	-1.1
5	4960.00	45.8 PK	74.0	-28.2	1.31 V	40	41.8	4.0
6	4960.00	19.6 AV	54.0	-34.4	1.31 V	40	15.6	4.0
7	7440.00	52.0 PK	74.0	-22.0	1.13 V	271	42.3	9.7
8	7440.00	25.8 AV	54.0	-28.2	1.13 V	271	16.1	9.7

Remarks:

- Emission Level(dBuV/m) = Raw Value(dBuV) + Correction Factor(dB/m)
- Correction Factor(dB/m) = Antenna Factor(dB/m) + Cable Factor(dB) – Pre-Amplifier Factor(dB)
- Margin value = Emission Level – Limit value
- The other emission levels were very low against the limit.
- " * ": Fundamental frequency.
- The average value of fundamental and harmonic frequency is: Average = Peak value + 20 log(Duty cycle) Where the duty factor is calculated from following formula:
 $20 \log(\text{Duty cycle}) = 20 \log(0.348 \text{ ms} / 7.106 \text{ ms}) = -26.2 \text{ dB}$
 Please see page 3.3 for plotted duty.

BT-LE 2M

RF Mode	TX BT_LE-2M	Channel	CH 1 : 2404 MHz
Frequency Range	1GHz ~ 25GHz	Detector Function	Peak (PK) Average (AV)

Antenna Polarity & Test Distance : Horizontal at 3 m								
No	Frequency (MHz)	Emission Level (dBuV/m)	Limit (dBuV/m)	Margin (dB)	Antenna Height (m)	Table Angle (Degree)	Raw Value (dBuV)	Correction Factor (dB/m)
1	2320.72	57.1 PK	74.0	-16.9	1.02 H	241	58.1	-1.0
2	2320.72	47.9 AV	54.0	-6.1	1.02 H	241	48.9	-1.0
3	2390.00	57.6 PK	74.0	-16.4	1.02 H	241	58.8	-1.2
4	2390.00	44.8 AV	54.0	-9.2	1.02 H	241	46.0	-1.2
5	*2404.00	101.4 PK			1.02 H	241	102.6	-1.2
6	*2404.00	69.5 AV			1.02 H	241	70.7	-1.2
7	2490.48	56.9 PK	74.0	-17.1	1.02 H	241	58.0	-1.1
8	2490.48	48.7 AV	54.0	-5.3	1.02 H	241	49.8	-1.1
9	4808.00	45.3 PK	74.0	-28.7	1.17 H	251	41.6	3.7
10	4808.00	13.4 AV	54.0	-40.6	1.17 H	251	9.7	3.7

Antenna Polarity & Test Distance : Vertical at 3 m								
No	Frequency (MHz)	Emission Level (dBuV/m)	Limit (dBuV/m)	Margin (dB)	Antenna Height (m)	Table Angle (Degree)	Raw Value (dBuV)	Correction Factor (dB/m)
1	2390.00	56.2 PK	74.0	-17.8	3.79 V	288	57.4	-1.2
2	2390.00	45.0 AV	54.0	-9.0	3.79 V	288	46.2	-1.2
3	*2404.00	97.5 PK			3.79 V	288	98.7	-1.2
4	*2404.00	65.6 AV			3.79 V	288	66.8	-1.2
5	4808.00	45.6 PK	74.0	-28.4	1.20 V	52	41.9	3.7
6	4808.00	13.7 AV	54.0	-40.3	1.20 V	52	10.0	3.7

Remarks:

- Emission Level(dBuV/m) = Raw Value(dBuV) + Correction Factor(dB/m)
- Correction Factor(dB/m) = Antenna Factor(dB/m) + Cable Factor(dB) – Pre-Amplifier Factor(dB)
- Margin value = Emission Level – Limit value
- The other emission levels were very low against the limit.
- " * ": Fundamental frequency.
- The average value of fundamental and harmonic frequency is: Average = Peak value + 20 log(Duty cycle) Where the duty factor is calculated from following formula:
 $20 \log(\text{Duty cycle}) = 20 \log(0.18 \text{ ms} / 7.055 \text{ ms}) = -31.9 \text{ dB}$
 Please see page 3.3 for plotted duty.

RF Mode	TX BT_LE-2M	Channel	CH 19 : 2440 MHz
Frequency Range	1GHz ~ 25GHz	Detector Function	Peak (PK) Average (AV)

Antenna Polarity & Test Distance : Horizontal at 3 m

No	Frequency (MHz)	Emission Level (dBuV/m)	Limit (dBuV/m)	Margin (dB)	Antenna Height (m)	Table Angle (Degree)	Raw Value (dBuV)	Correction Factor (dB/m)
1	*2440.00	100.8 PK			1.04 H	257	102.0	-1.2
2	*2440.00	68.9 AV			1.04 H	257	70.1	-1.2
3	4880.00	45.2 PK	74.0	-28.8	1.16 H	257	41.4	3.8
4	4880.00	13.3 AV	54.0	-40.7	1.16 H	257	9.5	3.8
5	7320.00	49.2 PK	74.0	-24.8	1.14 H	251	39.6	9.6
6	7320.00	17.3 AV	54.0	-36.7	1.14 H	251	7.7	9.6

Antenna Polarity & Test Distance : Vertical at 3 m

No	Frequency (MHz)	Emission Level (dBuV/m)	Limit (dBuV/m)	Margin (dB)	Antenna Height (m)	Table Angle (Degree)	Raw Value (dBuV)	Correction Factor (dB/m)
1	*2440.00	96.9 PK			3.92 V	306	98.1	-1.2
2	*2440.00	65.0 AV			3.92 V	306	66.2	-1.2
3	4880.00	45.8 PK	74.0	-28.2	1.33 V	45	42.0	3.8
4	4880.00	13.9 AV	54.0	-40.1	1.33 V	45	10.1	3.8
5	7320.00	52.0 PK	74.0	-22.0	1.13 V	262	42.4	9.6
6	7320.00	20.1 AV	54.0	-33.9	1.13 V	262	10.5	9.6

Remarks:

- Emission Level(dBuV/m) = Raw Value(dBuV) + Correction Factor(dB/m)
- Correction Factor(dB/m) = Antenna Factor(dB/m) + Cable Factor(dB) – Pre-Amplifier Factor(dB)
- Margin value = Emission Level – Limit value
- The other emission levels were very low against the limit.
- " * ": Fundamental frequency.
- The average value of fundamental and harmonic frequency is: Average = Peak value + 20 log(Duty cycle) Where the duty factor is calculated from following formula:
 $20 \log(\text{Duty cycle}) = 20 \log(0.18 \text{ ms} / 7.055 \text{ ms}) = -31.9 \text{ dB}$
 Please see page 3.3 for plotted duty.

RF Mode	TX BT_LE-2M	Channel	CH 38 : 2478 MHz
Frequency Range	1GHz ~ 25GHz	Detector Function	Peak (PK) Average (AV)

Antenna Polarity & Test Distance : Horizontal at 3 m								
No	Frequency (MHz)	Emission Level (dBuV/m)	Limit (dBuV/m)	Margin (dB)	Antenna Height (m)	Table Angle (Degree)	Raw Value (dBuV)	Correction Factor (dB/m)
1	*2478.00	100.3 PK			1.25 H	243	101.4	-1.1
2	*2478.00	68.4 AV			1.25 H	243	69.5	-1.1
3	2483.50	63.1 PK	74.0	-10.9	1.25 H	243	64.2	-1.1
4	2483.50	31.2 AV	54.0	-22.8	1.25 H	243	32.3	-1.1
5	4956.00	45.3 PK	74.0	-28.7	1.17 H	248	41.3	4.0
6	4956.00	13.4 AV	54.0	-40.6	1.17 H	248	9.4	4.0
7	7434.00	49.0 PK	74.0	-25.0	1.08 H	242	39.3	9.7
8	7434.00	17.1 AV	54.0	-36.9	1.08 H	242	7.4	9.7

Antenna Polarity & Test Distance : Vertical at 3 m								
No	Frequency (MHz)	Emission Level (dBuV/m)	Limit (dBuV/m)	Margin (dB)	Antenna Height (m)	Table Angle (Degree)	Raw Value (dBuV)	Correction Factor (dB/m)
1	*2478.00	96.6 PK			3.91 V	294	97.7	-1.1
2	*2478.00	64.7 AV			3.91 V	294	65.8	-1.1
3	2483.50	60.2 PK	74.0	-13.8	3.91 V	294	61.3	-1.1
4	2483.50	28.3 AV	54.0	-25.7	3.91 V	294	29.4	-1.1
5	4956.00	45.8 PK	74.0	-28.2	1.25 V	48	41.8	4.0
6	4956.00	13.9 AV	54.0	-40.1	1.25 V	48	9.9	4.0
7	7434.00	51.8 PK	74.0	-22.2	1.06 V	270	42.1	9.7
8	7434.00	19.9 AV	54.0	-34.1	1.06 V	270	10.2	9.7

Remarks:

1. Emission Level(dBuV/m) = Raw Value(dBuV) + Correction Factor(dB/m)
2. Correction Factor(dB/m) = Antenna Factor(dB/m) + Cable Factor(dB) – Pre-Amplifier Factor(dB)
3. Margin value = Emission Level – Limit value
4. The other emission levels were very low against the limit.
5. " * ": Fundamental frequency.
6. The average value of fundamental and harmonic frequency is: Average = Peak value + 20 log(Duty cycle) Where the duty factor is calculated from following formula:
 $20 \log(\text{Duty cycle}) = 20 \log(0.18 \text{ ms} / 7.055 \text{ ms}) = -31.9 \text{ dB}$
 Please see page 3.3 for plotted duty.

Below 1GHz Data:

RF Mode	TX BT_LE-1M	Channel	CH 0 : 2402 MHz
Frequency Range	9kHz ~ 1GHz	Detector Function	Quasi-Peak (QP)

Antenna Polarity & Test Distance : Horizontal at 3 m								
No	Frequency (MHz)	Emission Level (dBUV/m)	Limit (dBUV/m)	Margin (dB)	Antenna Height (m)	Table Angle (Degree)	Raw Value (dBUV)	Correction Factor (dB/m)
1	40.84	24.1 QP	40.0	-15.9	2.00 H	241	32.6	-8.5
2	63.48	21.1 QP	40.0	-18.9	2.50 H	261	30.3	-9.2
3	135.30	22.5 QP	43.5	-21.0	1.50 H	247	30.9	-8.4
4	197.20	22.1 QP	43.5	-21.4	1.00 H	249	32.7	-10.6
5	308.48	22.3 QP	46.0	-23.7	2.00 H	267	28.5	-6.2
6	439.54	27.0 QP	46.0	-19.0	1.50 H	349	29.3	-2.3

Remarks:

1. Emission Level(dBuV/m) = Raw Value(dBuV) + Correction Factor(dB/m)
2. Correction Factor(dB/m) = Antenna Factor(dB/m) + Cable Factor(dB) – Pre-Amplifier Factor(dB)
3. Margin value = Emission Level – Limit value
4. The other emission levels were very low against the limit of frequency range 30MHz~1000MHz.
5. The emission levels were very low against the limit of frequency range 9kHz~30MHz: the amplitude of spurious emissions attenuated more than 20 dB below the permissible value to be report.

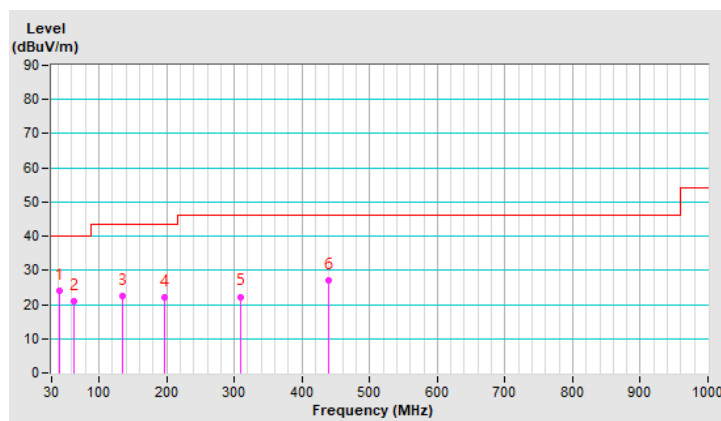

RF Mode	TX BT_LE-1M	Channel	CH 0 : 2402 MHz
Frequency Range	9kHz ~ 1GHz	Detector Function	Quasi-Peak (QP)

Antenna Polarity & Test Distance : Vertical at 3 m

No	Frequency (MHz)	Emission Level (dBuV/m)	Limit (dBuV/m)	Margin (dB)	Antenna Height (m)	Table Angle (Degree)	Raw Value (dBuV)	Correction Factor (dB/m)
1	41.28	33.1 QP	40.0	-6.9	1.00 V	142	41.5	-8.4
2	73.83	23.3 QP	40.0	-16.7	1.00 V	351	34.7	-11.4
3	87.92	23.2 QP	40.0	-16.8	1.00 V	16	37.1	-13.9
4	196.03	21.0 QP	43.5	-22.5	2.50 V	142	31.6	-10.6
5	229.11	21.5 QP	46.0	-24.5	2.00 V	328	31.6	-10.1
6	570.89	29.6 QP	46.0	-16.4	1.00 V	187	29.3	0.3

Remarks:

1. Emission Level(dBuV/m) = Raw Value(dBuV) + Correction Factor(dB/m)
2. Correction Factor(dB/m) = Antenna Factor(dB/m) + Cable Factor(dB) – Pre-Amplifier Factor(dB)
3. Margin value = Emission Level – Limit value
4. The other emission levels were very low against the limit of frequency range 30MHz~1000MHz.
5. The emission levels were very low against the limit of frequency range 9kHz~30MHz: the amplitude of spurious emissions attenuated more than 20 dB below the permissible value to be report.

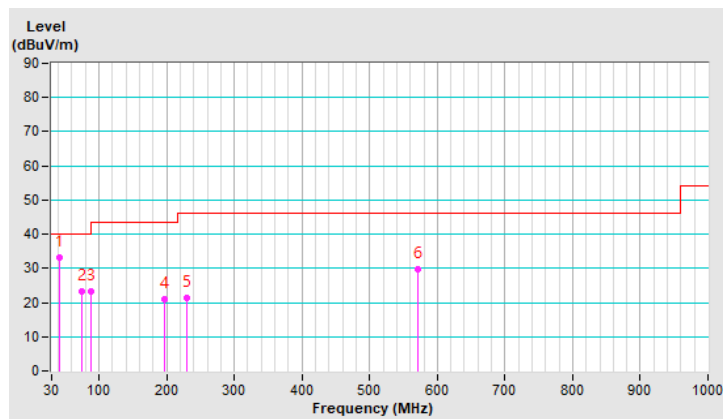

4.2 Conducted Emission Measurement

4.2.1 Limits of Conducted Emission Measurement

Frequency (MHz)	Conducted Limit (dBuV)	
	Quasi-peak	Average
0.15 - 0.5	66 - 56	56 - 46
0.50 - 5.0	56	46
5.0 - 30.0	60	50

Note: 1. The lower limit shall apply at the transition frequencies.

2. The limit decreases in line with the logarithm of the frequency in the range of 0.15 to 0.50MHz.

4.2.2 Test Instruments

DESCRIPTION & MANUFACTURER	MODEL NO.	SERIAL NO.	CALIBRATED DATE	CALIBRATED UNTIL
Test Receiver R&S	ESCS 30	847124/029	Oct. 20, 2020	Oct. 19, 2021
Line-Impedance Stabilization Network (for EUT) R&S	ESH3-Z5	848773/004	Oct. 27, 2020	Oct. 26, 2021
Line-Impedance Stabilization Network (for Peripheral) R&S	ESH3-Z5	835239/001	Mar. 26, 2021	Mar. 25, 2022
50 ohms Terminator	50	3	Oct. 26, 2020	Oct. 25, 2021
RF Cable	5D-FB	COCCAB-001	Sep. 26, 2020	Sep. 25, 2021
Fixed attenuator EMCI	STI02-2200-10	005	Aug. 29, 2020	Aug. 28, 2021
Software BVADT	BVADT_Cond_ V7.3.7.4	NA	NA	NA

Note:

1. The calibration interval of the above test instruments are 12 months and the calibrations are traceable to NML/ROC and NIST/USA.
2. The test was performed in Conduction 1.
- 3 Tested Date: May 24, 2021

4.2.3 Test Procedures

- a. The EUT was placed 0.4 meters from the conducting wall of the shielded room with EUT being connected to the power mains through a line impedance stabilization network (LISN). Other support units were connected to the power mains through another LISN. The two LISNs provide 50 ohm/ 50uH of coupling impedance for the measuring instrument.
- b. Both lines of the power mains connected to the EUT were checked for maximum conducted interference.
- c. The frequency range from 150kHz to 30MHz was searched. Emission levels under (Limit - 20dB) was not recorded.

Note: The resolution bandwidth and video bandwidth of test receiver is 9kHz for quasi-peak detection (QP) and average detection (AV) at frequency 0.15MHz-30MHz.

4.2.4 Deviation from Test Standard

No deviation.

4.2.5 Test Setup

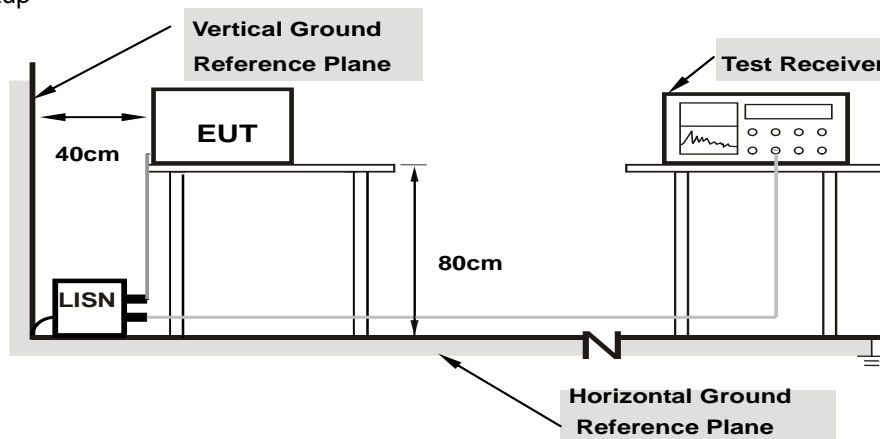

Note: 1.Support units were connected to second LISN.

For the actual test configuration, please refer to the attached file (Test Setup Photo).

4.2.6 EUT Operating Conditions

- a. Placed the EUT on the testing table.
 - b. Controlling software (RF Sample with Receiver [Number Lock]) has been activated to set the EUT under transmission condition continuously at specific channel frequency.
- ◆ BLE1M TX Modulated low duty cycle on channel 2402MHz

4.2.7 Test Results

BT-LE function

RF Mode	TX BT-LE 1M	Channel	CH 0 : 2402 MHz
Frequency Range	150kHz ~ 30MHz	Detector Function & Resolution Bandwidth	Quasi-Peak (QP) / Average (AV), 9kHz

Phase Of Power : Line (L)										
No	Frequency (MHz)	Correction Factor (dB)	Reading Value (dBuV)		Emission Level (dBuV)		Limit (dBuV)		Margin (dB)	
			Q.P.	AV.	Q.P.	AV.	Q.P.	AV.	Q.P.	AV.
1	0.17734	9.98	31.73	18.83	41.71	28.81	64.61	54.61	-22.90	-25.80
2	0.50547	10.03	25.99	16.84	36.02	26.87	56.00	46.00	-19.98	-19.13
3	0.59531	10.03	26.77	15.51	36.80	25.54	56.00	46.00	-19.20	-20.46
4	0.89609	10.05	22.47	11.22	32.52	21.27	56.00	46.00	-23.48	-24.73
5	0.98984	10.06	14.44	-6.45	24.50	3.61	56.00	46.00	-31.50	-42.39
6	3.54688	10.25	17.34	4.36	27.59	14.61	56.00	46.00	-28.41	-31.39

Remarks:

1. Q.P. and AV. are abbreviations of quasi-peak and average individually.
2. The emission levels of other frequencies were very low against the limit.
3. Margin value = Emission level – Limit value
4. Correction factor = Insertion loss + Cable loss
5. Emission Level = Correction Factor + Reading Value

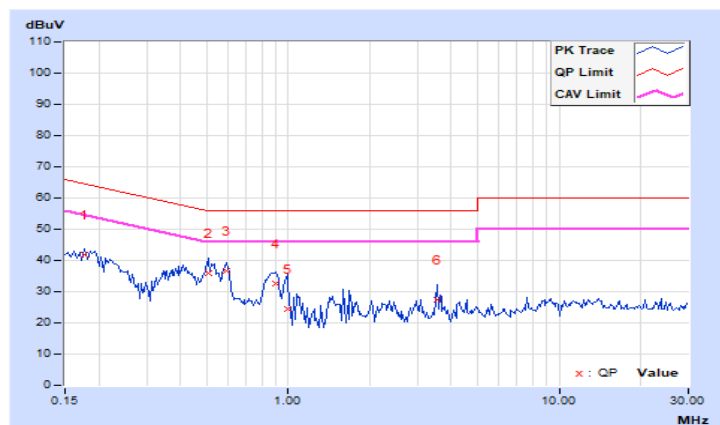

RF Mode	TX BT-LE 1M	Channel	CH 0 : 2402 MHz
Frequency Range	150kHz ~ 30MHz	Detector Function & Resolution Bandwidth	Quasi-Peak (QP) / Average (AV), 9kHz

Phase Of Power : Neutral (N)										
No	Frequency (MHz)	Correction Factor (dB)	Reading Value (dBuV)		Emission Level (dBuV)		Limit (dBuV)		Margin (dB)	
			Q.P.	AV.	Q.P.	AV.	Q.P.	AV.	Q.P.	AV.
1	0.17734	9.96	23.72	4.25	33.68	14.21	64.61	54.61	-30.93	-40.40
2	0.19687	9.98	22.93	4.43	32.91	14.41	63.74	53.74	-30.83	-39.33
3	0.21250	9.98	20.68	2.98	30.66	12.96	63.11	53.11	-32.45	-40.15
4	0.57969	10.03	21.79	5.01	31.82	15.04	56.00	46.00	-24.18	-30.96
5	0.90000	10.06	14.54	-0.62	24.60	9.44	56.00	46.00	-31.40	-36.56
6	1.74609	10.12	11.78	-3.24	21.90	6.88	56.00	46.00	-34.10	-39.12

Remarks:

1. Q.P. and AV. are abbreviations of quasi-peak and average individually.
2. The emission levels of other frequencies were very low against the limit.
3. Margin value = Emission level – Limit value
4. Correction factor = Insertion loss + Cable loss
5. Emission Level = Correction Factor + Reading Value

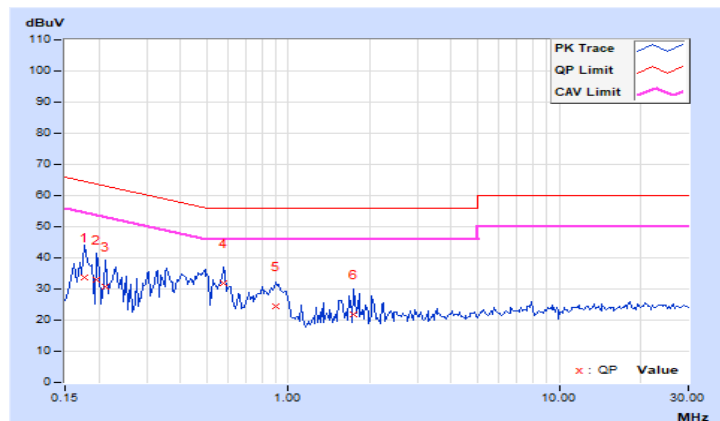

logi bolt function

RF Mode	TX BT-LE 1M	Channel	CH 0 : 2402 MHz
Frequency Range	150kHz ~ 30MHz	Detector Function & Resolution Bandwidth	Quasi-Peak (QP) / Average (AV), 9kHz

Phase Of Power : Line (L)										
No	Frequency (MHz)	Correction Factor (dB)	Reading Value (dBuV)		Emission Level (dBuV)		Limit (dBuV)		Margin (dB)	
			Q.P.	AV.	Q.P.	AV.	Q.P.	AV.	Q.P.	AV.
1	0.15000	9.96	27.35	3.91	37.31	13.87	66.00	56.00	-28.69	-42.13
2	0.17734	9.98	27.00	2.28	36.98	12.26	64.61	54.61	-27.63	-42.35
3	0.33359	10.01	21.77	-2.83	31.78	7.18	59.36	49.36	-27.58	-42.18
4	0.50938	10.03	20.24	6.01	30.27	16.04	56.00	46.00	-25.73	-29.96
5	0.57969	10.03	22.89	-0.90	32.92	9.13	56.00	46.00	-23.08	-36.87
6	0.88438	10.05	13.01	-7.40	23.06	2.65	56.00	46.00	-32.94	-43.35

Remarks:

1. Q.P. and AV. are abbreviations of quasi-peak and average individually.
2. The emission levels of other frequencies were very low against the limit.
3. Margin value = Emission level – Limit value
4. Correction factor = Insertion loss + Cable loss
5. Emission Level = Correction Factor + Reading Value

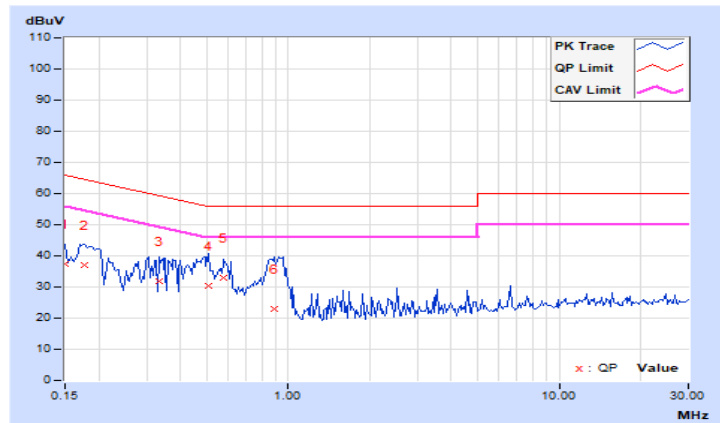

RF Mode	TX BT-LE 1M	Channel	CH 0 : 2402 MHz
Frequency Range	150kHz ~ 30MHz	Detector Function & Resolution Bandwidth	Quasi-Peak (QP) / Average (AV), 9kHz

Phase Of Power : Neutral (N)										
No	Frequency (MHz)	Correction Factor (dB)	Reading Value (dBuV)		Emission Level (dBuV)		Limit (dBuV)		Margin (dB)	
			Q.P.	AV.	Q.P.	AV.	Q.P.	AV.	Q.P.	AV.
1	0.15781	9.95	26.99	10.67	36.94	20.62	65.58	55.58	-28.64	-34.96
2	0.17344	9.96	30.41	14.58	40.37	24.54	64.79	54.79	-24.42	-30.25
3	0.19297	9.97	28.26	14.55	38.23	24.52	63.91	53.91	-25.68	-29.39
4	0.34141	10.00	18.00	1.21	28.00	11.21	59.17	49.17	-31.17	-37.96
5	0.50547	10.02	20.56	3.95	30.58	13.97	56.00	46.00	-25.42	-32.03
6	1.45703	10.10	9.45	-5.00	19.55	5.10	56.00	46.00	-36.45	-40.90

Remarks:

1. Q.P. and AV. are abbreviations of quasi-peak and average individually.
2. The emission levels of other frequencies were very low against the limit.
3. Margin value = Emission level – Limit value
4. Correction factor = Insertion loss + Cable loss
5. Emission Level = Correction Factor + Reading Value

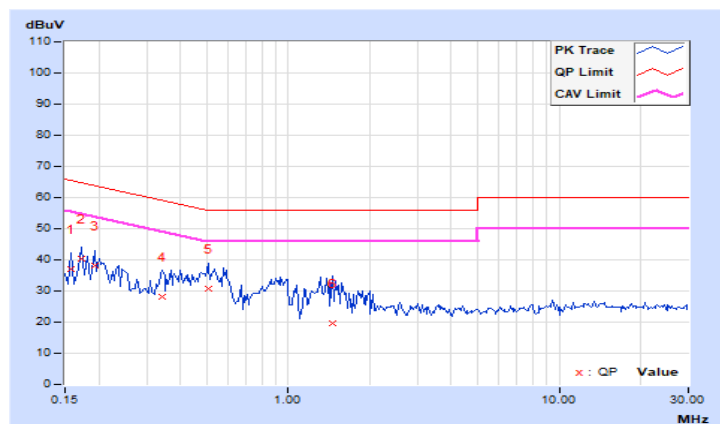

4.3 6dB Bandwidth Measurement

4.3.1 Limits of 6dB Bandwidth Measurement

The minimum of 6dB Bandwidth Measurement is 0.5 MHz.

4.3.2 Test Setup

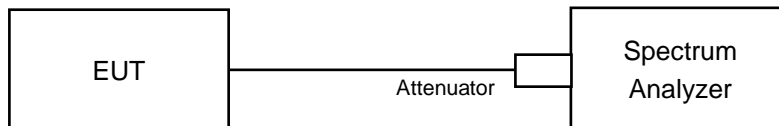

4.3.3 Test Instruments

Refer to section 4.1.2 to get information of above instrument.

4.3.4 Test Procedure

- a. Set resolution bandwidth (RBW) = 100kHz
- b. Set the video bandwidth (VBW) $\geq 3 \times$ RBW, Detector = Peak.
- c. Trace mode = max hold.
- d. Sweep = auto couple.
- e. Measure the maximum width of the emission that is constrained by the frequencies associated with the two amplitude points (upper and lower) that are attenuated by 6 dB relative to the maximum level measured in the fundamental emission

4.3.5 Deviation from Test Standard

No deviation.

4.3.6 EUT Operating Conditions

The software provided by client to enable the EUT under transmission condition continuously at lowest, middle and highest channel frequencies individually.

- ◆ BLE1M TX Modulated low duty cycle on channel 2402MHz
- ◆ BLE1M TX Modulated low duty cycle on channel 2440MHz
- ◆ BLE1M TX Modulated low duty cycle on channel 2480MHz
- ◆ BLE2M TX Modulated low duty cycle on channel 2404MHz
- ◆ BLE2M TX Modulated low duty cycle on channel 2440MHz
- ◆ BLE2M TX Modulated low duty cycle on channel 2478MHz

4.3.7 Test Results

BT-LE function

BT-LE 1M

Channel	Frequency (MHz)	6dB Bandwidth (MHz)	Minimum Limit (MHz)	Pass / Fail
0	2402	0.69	0.5	Pass
19	2440	0.7	0.5	Pass
39	2480	0.69	0.5	Pass

BT-LE 2M

Channel	Frequency (MHz)	6dB Bandwidth (MHz)	Minimum Limit (MHz)	Pass / Fail
1	2404	1.15	0.5	Pass
19	2440	1.17	0.5	Pass
38	2478	1.15	0.5	Pass

Spectrum Plot of Worst Value

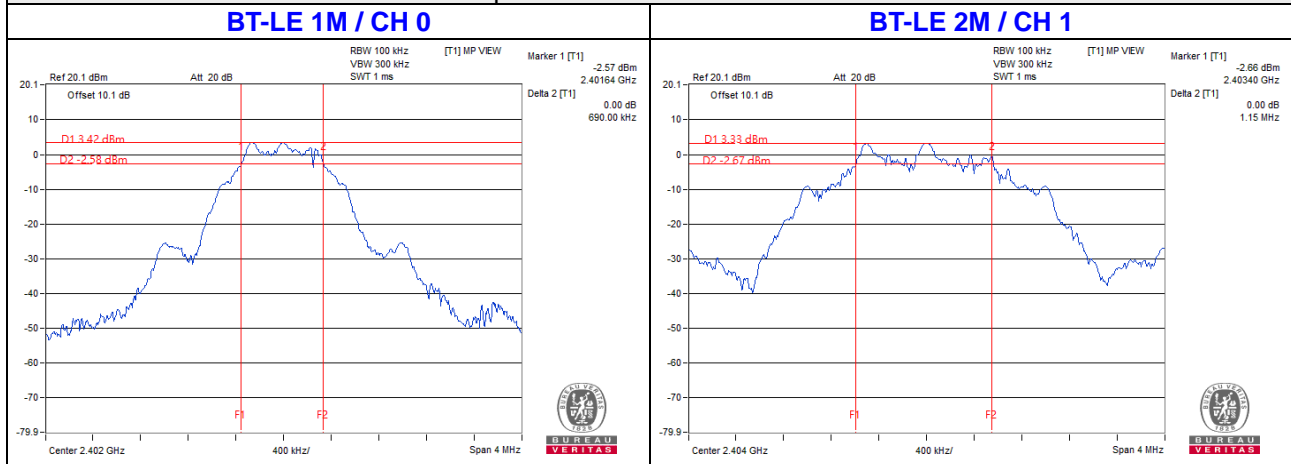

logi bolt function

BT-LE 1M

Channel	Frequency (MHz)	6dB Bandwidth (MHz)	Minimum Limit (MHz)	Pass / Fail
0	2402	0.7	0.5	Pass
19	2440	0.69	0.5	Pass
39	2480	0.69	0.5	Pass

BT-LE 2M

Channel	Frequency (MHz)	6dB Bandwidth (MHz)	Minimum Limit (MHz)	Pass / Fail
1	2404	1.16	0.5	Pass
19	2440	1.03	0.5	Pass
38	2478	1.15	0.5	Pass

Spectrum Plot of Worst Value

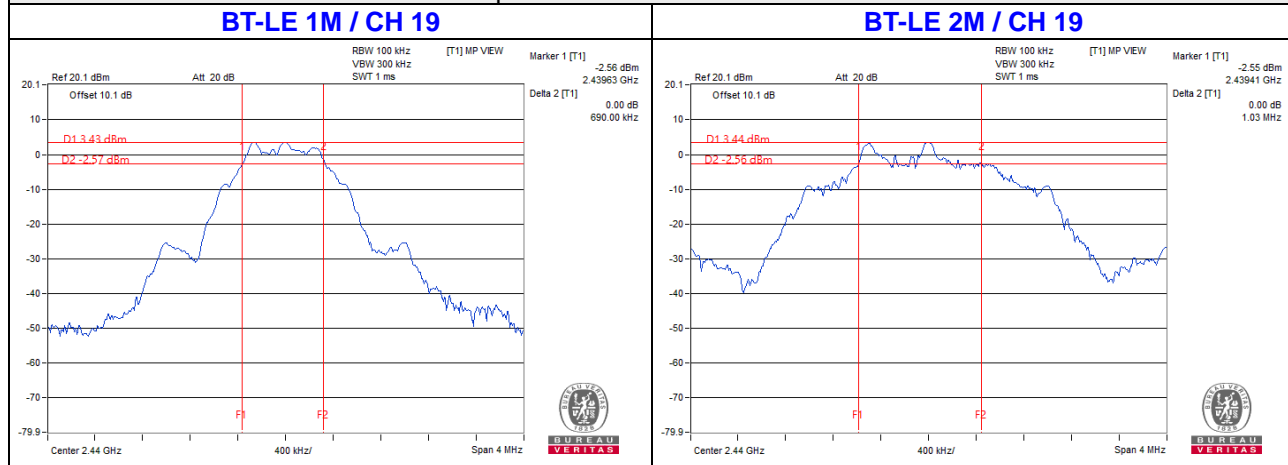

4.4 Conducted Output Power Measurement

4.4.1 Limits of Conducted Output Power Measurement

For systems using digital modulation in the 2400–2483.5 MHz bands: 1 Watt (30dBm)

4.4.2 Test Setup

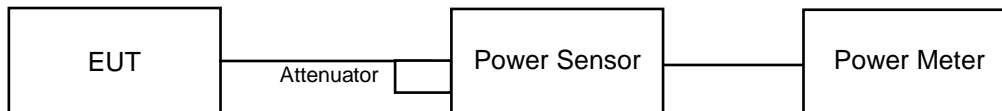

4.4.3 Test Instruments

Refer to section 4.1.2 to get information of above instrument.

4.4.4 Test Procedures

A peak power sensor was used on the output port of the EUT. A power meter was used to read the response of the peak power sensor. Record the power level.

Average power sensor was used to perform output power measurement, trigger and gating function of wide band power meter is enabled to measure max output power of TX on burst. Duty factor is not added to measured value.

4.4.5 Deviation from Test Standard

No deviation.

4.4.6 EUT Operating Conditions

The software provided by client to enable the EUT under transmission condition continuously at lowest, middle and highest channel frequencies individually.

- ◆ BLE1M TX Modulated low duty cycle on channel 2402MHz
- ◆ BLE1M TX Modulated low duty cycle on channel 2440MHz
- ◆ BLE1M TX Modulated low duty cycle on channel 2480MHz
- ◆ BLE2M TX Modulated low duty cycle on channel 2404MHz
- ◆ BLE2M TX Modulated low duty cycle on channel 2440MHz
- ◆ BLE2M TX Modulated low duty cycle on channel 2478MHz

4.4.7 Test Results

BT-LE function:

FOR PEAK POWER

BT-LE 1M

Channel	Frequency (MHz)	Peak Power (mW)	Peak Power (dBm)	Limit (dBm)	Pass/Fail
0	2402	2.382	3.77	30	Pass
19	2440	2.333	3.68	30	Pass
39	2480	2.275	3.57	30	Pass

BT-LE 2M

Channel	Frequency (MHz)	Peak Power (mW)	Peak Power (dBm)	Limit (dBm)	Pass/Fail
1	2404	2.377	3.76	30	Pass
19	2440	2.328	3.67	30	Pass
38	2478	2.27	3.56	30	Pass

FOR AVERAGE POWER

BT-LE 1M

Channel	Frequency (MHz)	Average Power (mW)	Average Power (dBm)
0	2402	2.36	3.73
19	2440	2.312	3.64
39	2480	2.254	3.53

BT-LE 2M

Channel	Frequency (MHz)	Average Power (mW)	Average Power (dBm)
1	2404	2.355	3.72
19	2440	2.312	3.64
38	2478	2.259	3.54

logi bolt function:

FOR PEAK POWER

BT-LE 1M

Channel	Frequency (MHz)	Peak Power (mW)	Peak Power (dBm)	Limit (dBm)	Pass/Fail
0	2402	2.355	3.72	30	Pass
19	2440	2.286	3.59	30	Pass
39	2480	2.239	3.50	30	Pass

BT-LE 2M

Channel	Frequency (MHz)	Peak Power (mW)	Peak Power (dBm)	Limit (dBm)	Pass/Fail
1	2404	2.344	3.70	30	Pass
19	2440	2.286	3.59	30	Pass
38	2478	2.244	3.51	30	Pass

FOR AVERAGE POWER

BT-LE 1M

Channel	Frequency (MHz)	Average Power (mW)	Average Power (dBm)
0	2402	2.323	3.66
19	2440	2.27	3.56
39	2480	2.213	3.45

BT-LE 2M

Channel	Frequency (MHz)	Average Power (mW)	Average Power (dBm)
1	2404	2.307	3.63
19	2440	2.265	3.55
38	2478	2.223	3.47

4.5 Power Spectral Density Measurement

4.5.1 Limits of Power Spectral Density Measurement

The Maximum of Power Spectral Density Measurement is 8dBm in any 3 kHz.

4.5.2 Test Setup

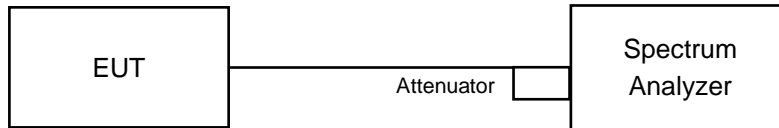

4.5.3 Test Instruments

Refer to section 4.1.2 to get information of above instrument.

4.5.4 Test Procedure

- a. Set analyzer center frequency to DTS channel center frequency.
- b. Set the span to 1.5 times the DTS bandwidth.
- c. Set the RBW to: $3 \text{ kHz} \leq \text{RBW} \leq 100 \text{ kHz}$.
- d. Set the VBW $\geq 3 \times \text{RBW}$.
- e. Detector = peak.
- f. Sweep time = auto couple.
- g. Trace mode = max hold.
- h. Allow trace to fully stabilize.
- i. Use the peak marker function to determine the maximum amplitude level within the RBW.

4.5.5 Deviation from Test Standard

No deviation.

4.5.6 EUT Operating Condition

The software provided by client to enable the EUT under transmission condition continuously at lowest, middle and highest channel frequencies individually.

- ◆ BLE1M TX Modulated low duty cycle on channel 2402MHz
- ◆ BLE1M TX Modulated low duty cycle on channel 2440MHz
- ◆ BLE1M TX Modulated low duty cycle on channel 2480MHz
- ◆ BLE2M TX Modulated low duty cycle on channel 2404MHz
- ◆ BLE2M TX Modulated low duty cycle on channel 2440MHz
- ◆ BLE2M TX Modulated low duty cycle on channel 2478MHz

4.5.7 Test Results

BT-LE function:

BT-LE 1M

Channel	Freq. (MHz)	PSD (dBm/3kHz)	Limit (dBm/3kHz)	Pass /Fail
0	2402	-0.05	8	Pass
19	2440	0.12	8	Pass
39	2480	0.01	8	Pass

BT-LE 2M

Channel	Freq. (MHz)	PSD (dBm/3kHz)	Limit (dBm/3kHz)	Pass /Fail
1	2404	-3.85	8	Pass
19	2440	-3.84	8	Pass
38	2478	-4.35	8	Pass

Spectrum Plot of Worst Value

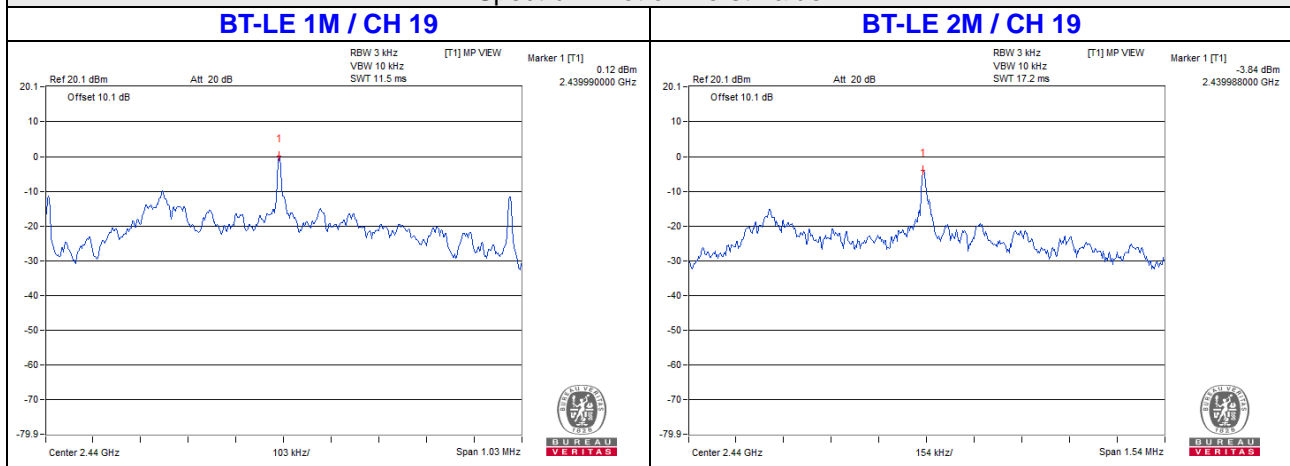

logi bolt function:

BT-LE 1M

Channel	Freq. (MHz)	PSD (dBm/3kHz)	Limit (dBm/3kHz)	Pass /Fail
0	2402	-0.06	8	Pass
19	2440	0.02	8	Pass
39	2480	-0.06	8	Pass

BT-LE 2M

Channel	Freq. (MHz)	PSD (dBm/3kHz)	Limit (dBm/3kHz)	Pass /Fail
1	2404	-3.96	8	Pass
19	2440	-4.90	8	Pass
38	2478	-4.45	8	Pass

Spectrum Plot of Worst Value

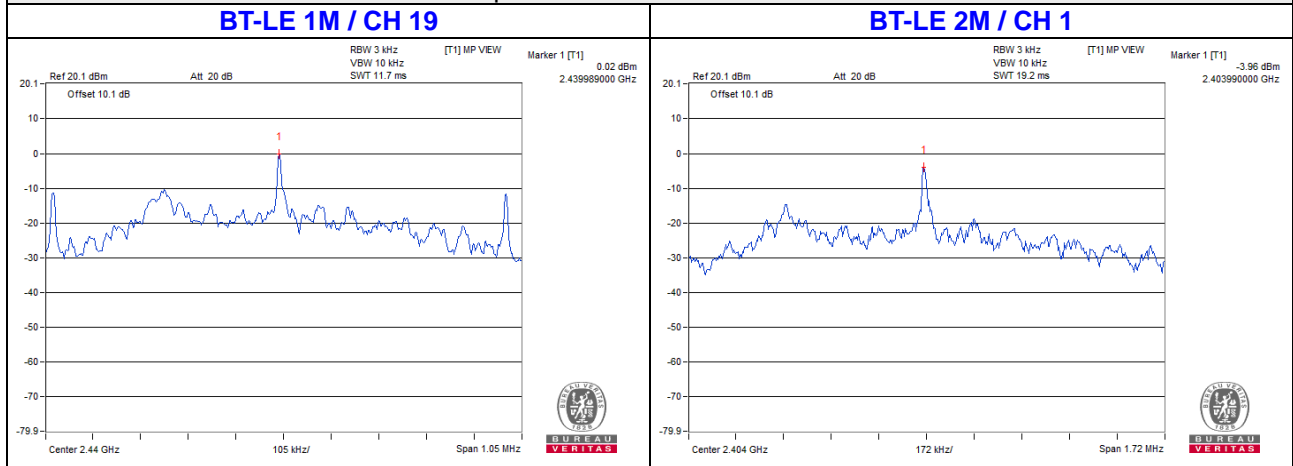

4.6 Conducted Out of Band Emission Measurement

4.6.1 Limits of Conducted Out of Band Emission Measurement

Below 20dB of the highest emission level of operating band (in 100kHz Resolution Bandwidth).

4.6.2 Test Setup

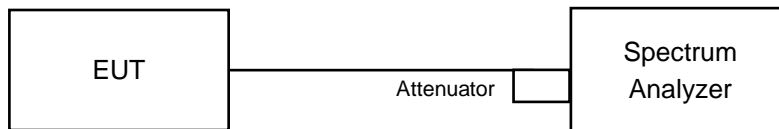

4.6.3 Test Instruments

Refer to section 4.1.2 to get information of above instrument.

4.6.4 Test Procedure

MEASUREMENT PROCEDURE REF

1. Set the RBW = 100 kHz.
2. Set the VBW \geq 300 kHz.
3. Detector = peak.
4. Sweep time = auto couple.
5. Trace mode = max hold.
6. Allow trace to fully stabilize.
7. Use the peak marker function to determine the maximum power level in any 100 kHz band segment within the fundamental EBW.

MEASUREMENT PROCEDURE OOB

1. Set RBW = 100 kHz.
2. Set VBW \geq 300 kHz.
3. Detector = peak.
4. Sweep = auto couple.
5. Trace Mode = max hold.
6. Allow trace to fully stabilize.
7. Use the peak marker function to determine the maximum amplitude level.

4.6.5 Deviation from Test Standard

No deviation.

4.6.6 EUT Operating Condition

The software provided by client enabled the EUT to transmit and receive data at lowest and highest channel frequencies individually.

- ◆ BLE1M TX Modulated low duty cycle on channel 2402MHz
- ◆ BLE1M TX Modulated low duty cycle on channel 2440MHz
- ◆ BLE1M TX Modulated low duty cycle on channel 2480MHz
- ◆ BLE2M TX Modulated low duty cycle on channel 2404MHz
- ◆ BLE2M TX Modulated low duty cycle on channel 2440MHz
- ◆ BLE2M TX Modulated low duty cycle on channel 2478MHz

4.6.7 Test Results

The spectrum plots are attached on the following pages. D1 line indicates the highest level, and D2 line indicates the 20dB offset below D1. It shows compliance with the requirement.

**BT-LE function:
BT-LE 1M**

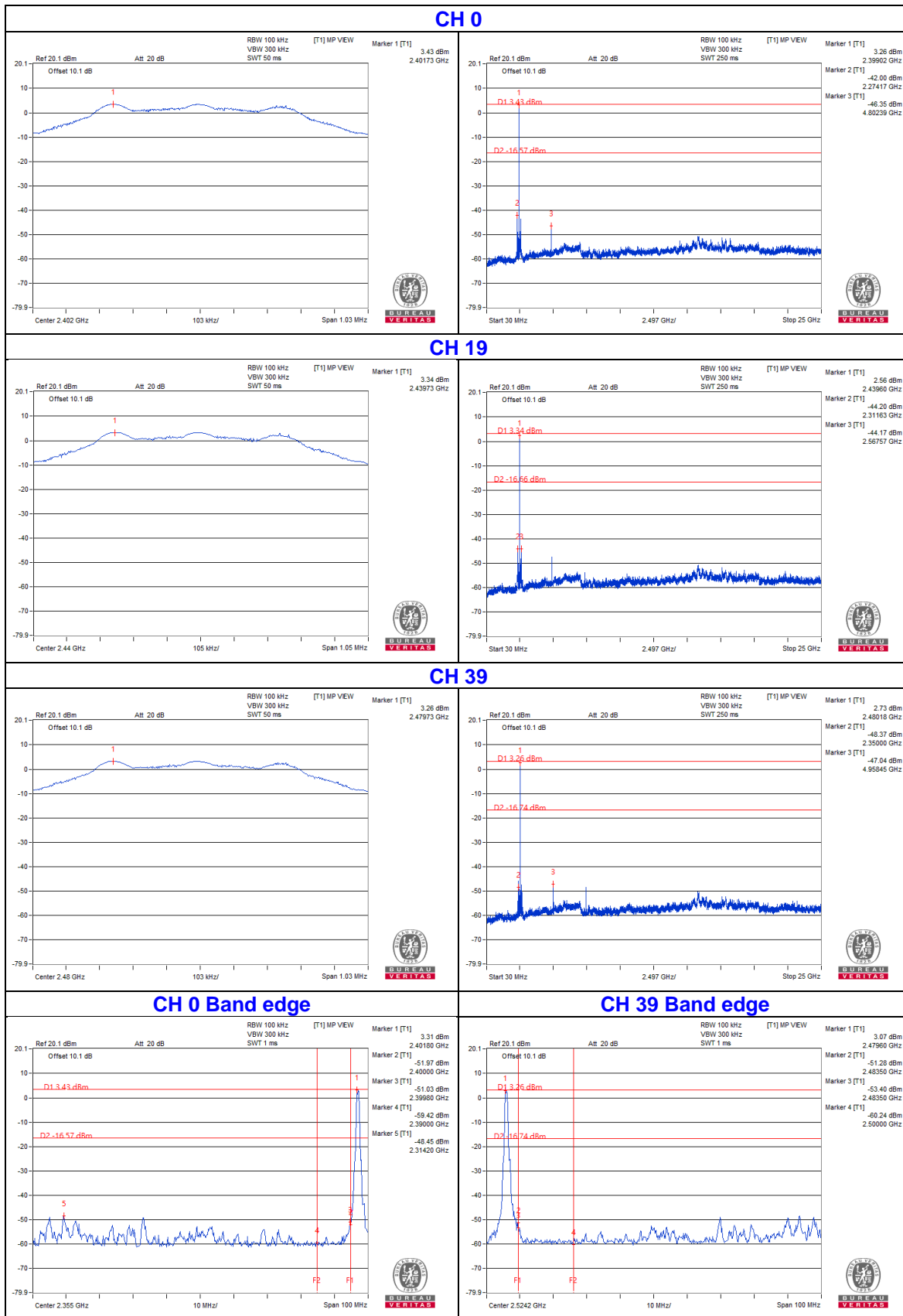

BT-LE 2M

CH 1

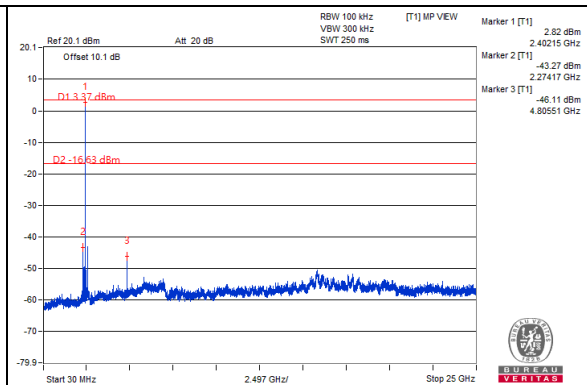
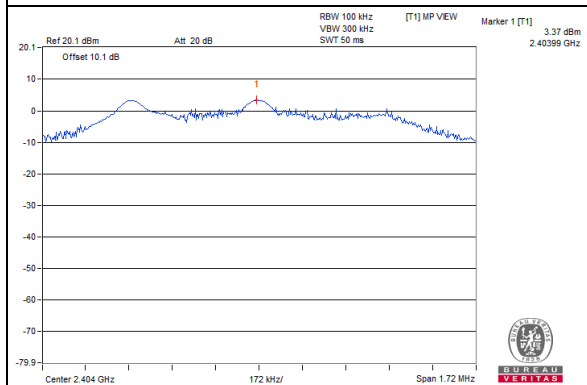

CH 19

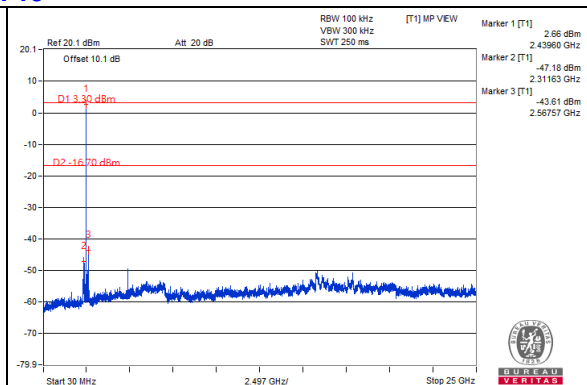
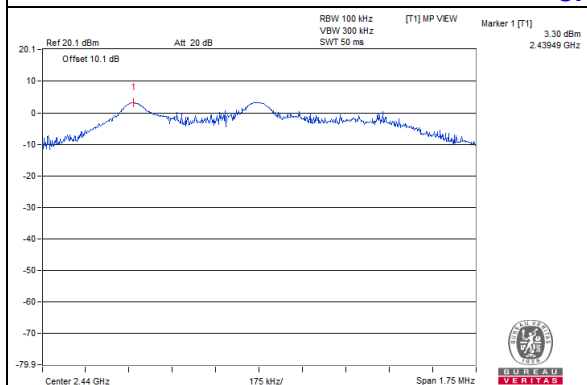

CH 38

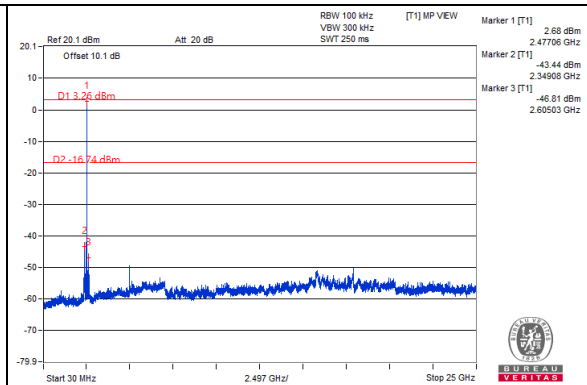
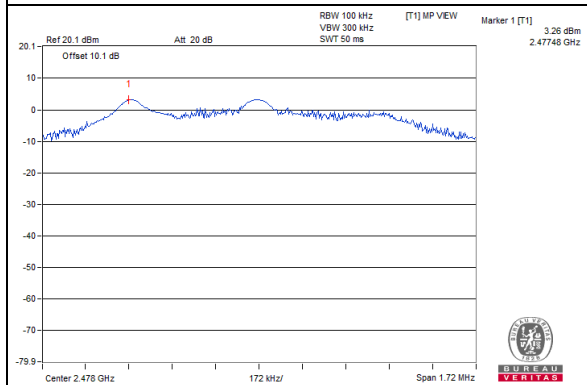

CH 1 Band edge

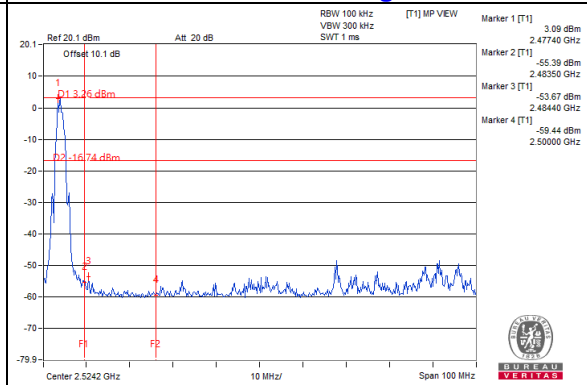
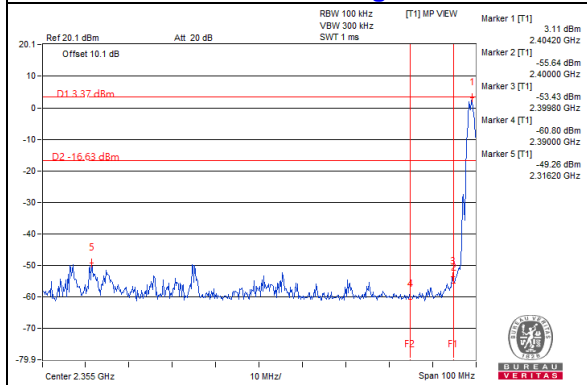

logi bolt function:
BT-LE 1M

CH 0

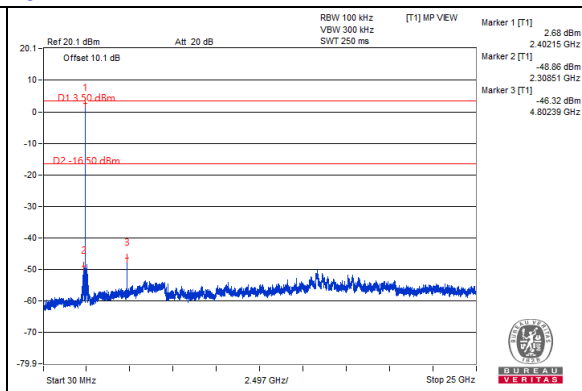
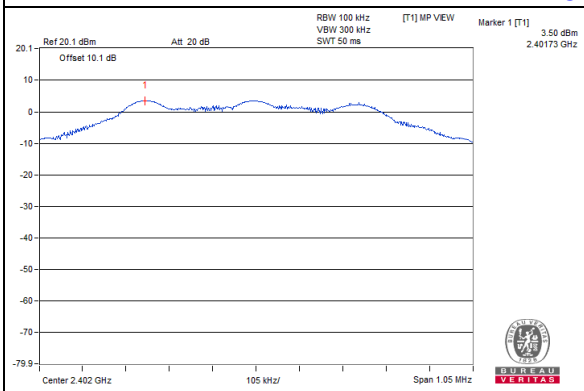

CH 19

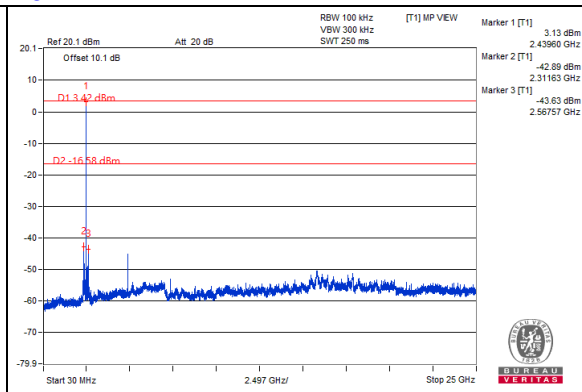
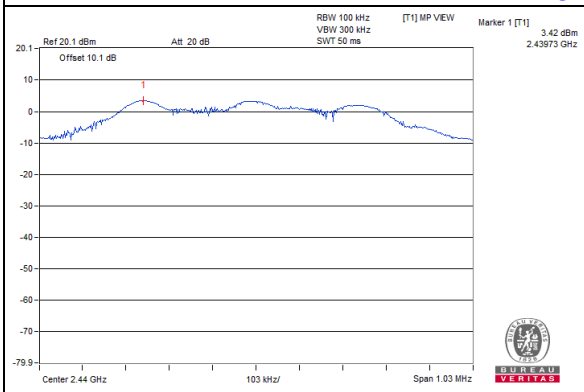

CH 39

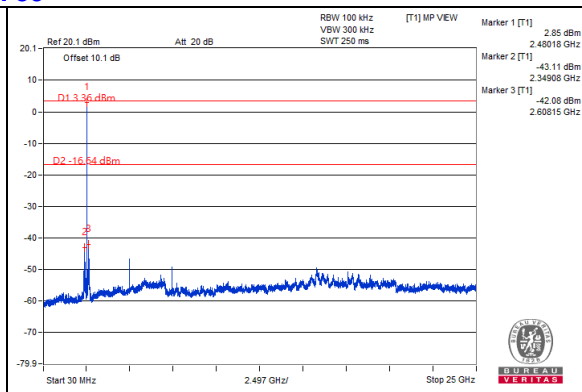
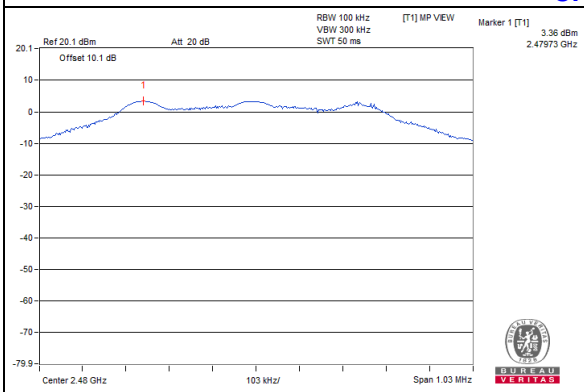

CH 0 Band edge

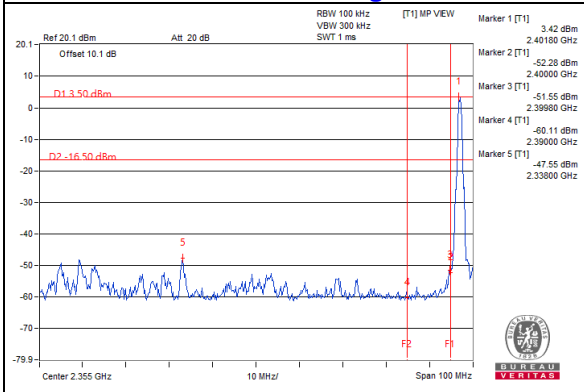

CH 39 Band edge

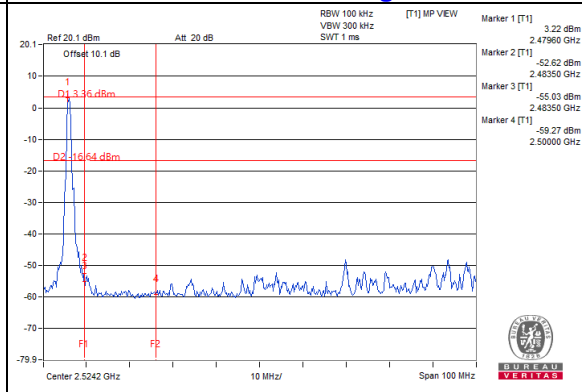

BT-LE 2M

CH 1

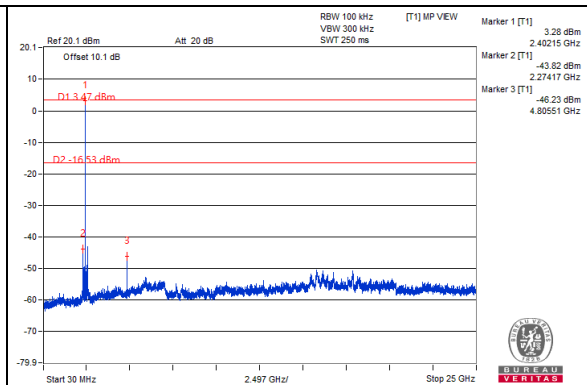
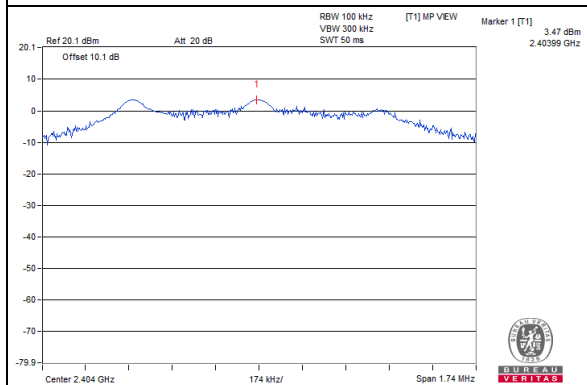

CH 19

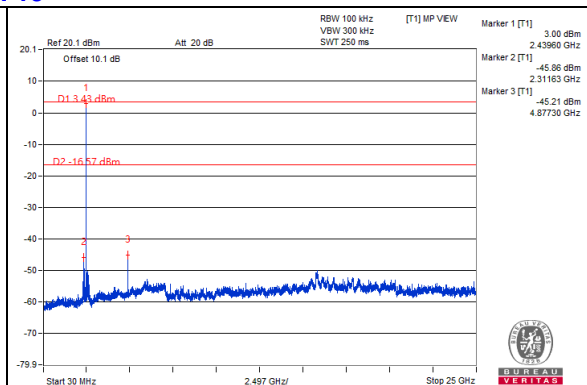
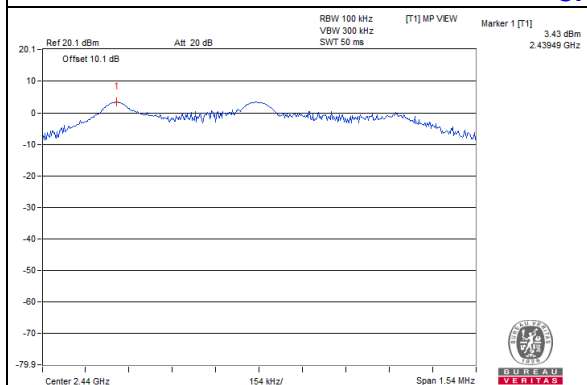

CH 38

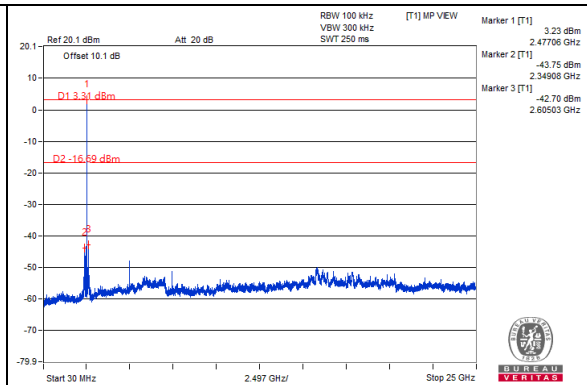
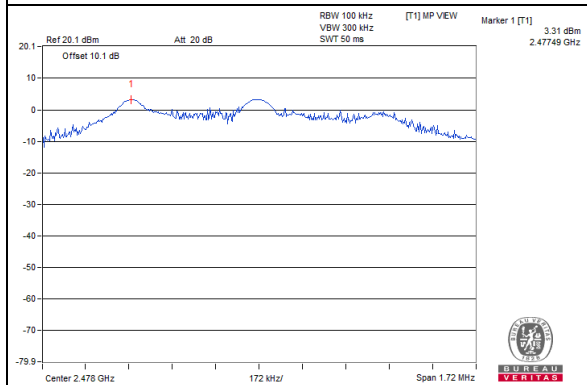

CH 1 Band edge

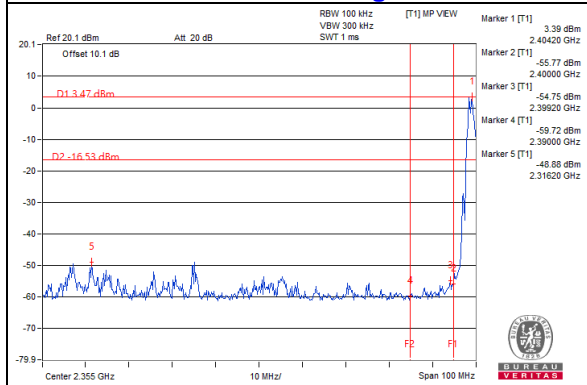

CH 38 Band edge

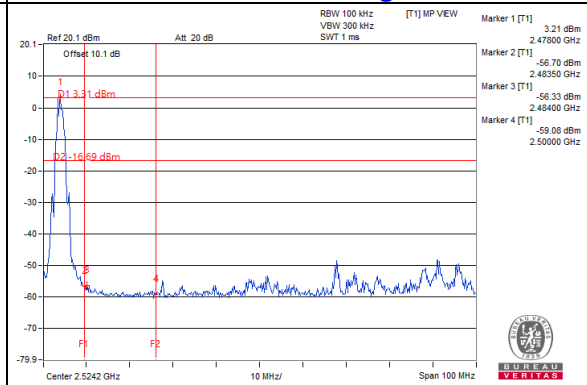

5 Pictures of Test Arrangements

Please refer to the attached file (Test Setup Photo).

Annex A - Band-Edge Measurement

BT-LE function:

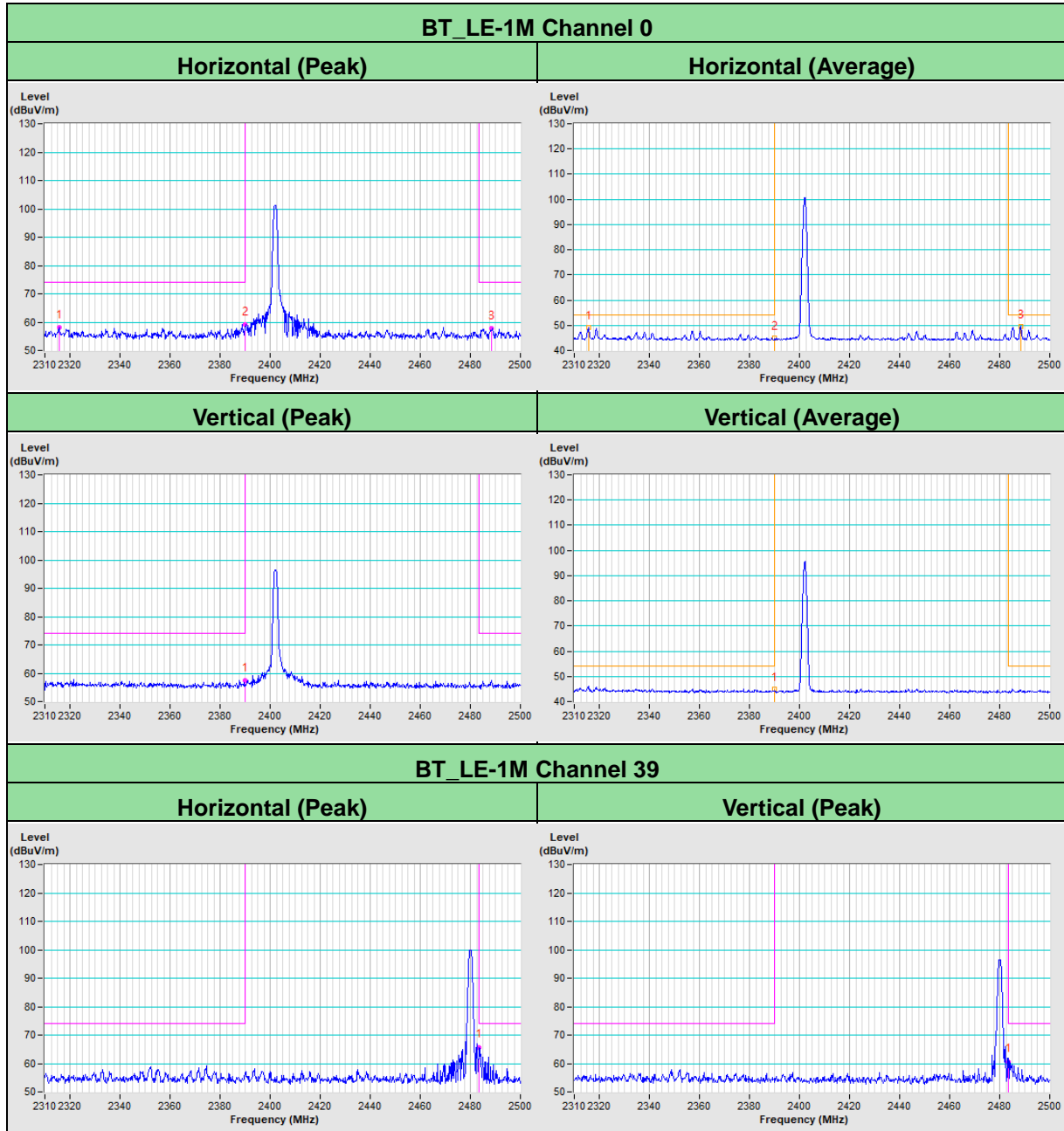

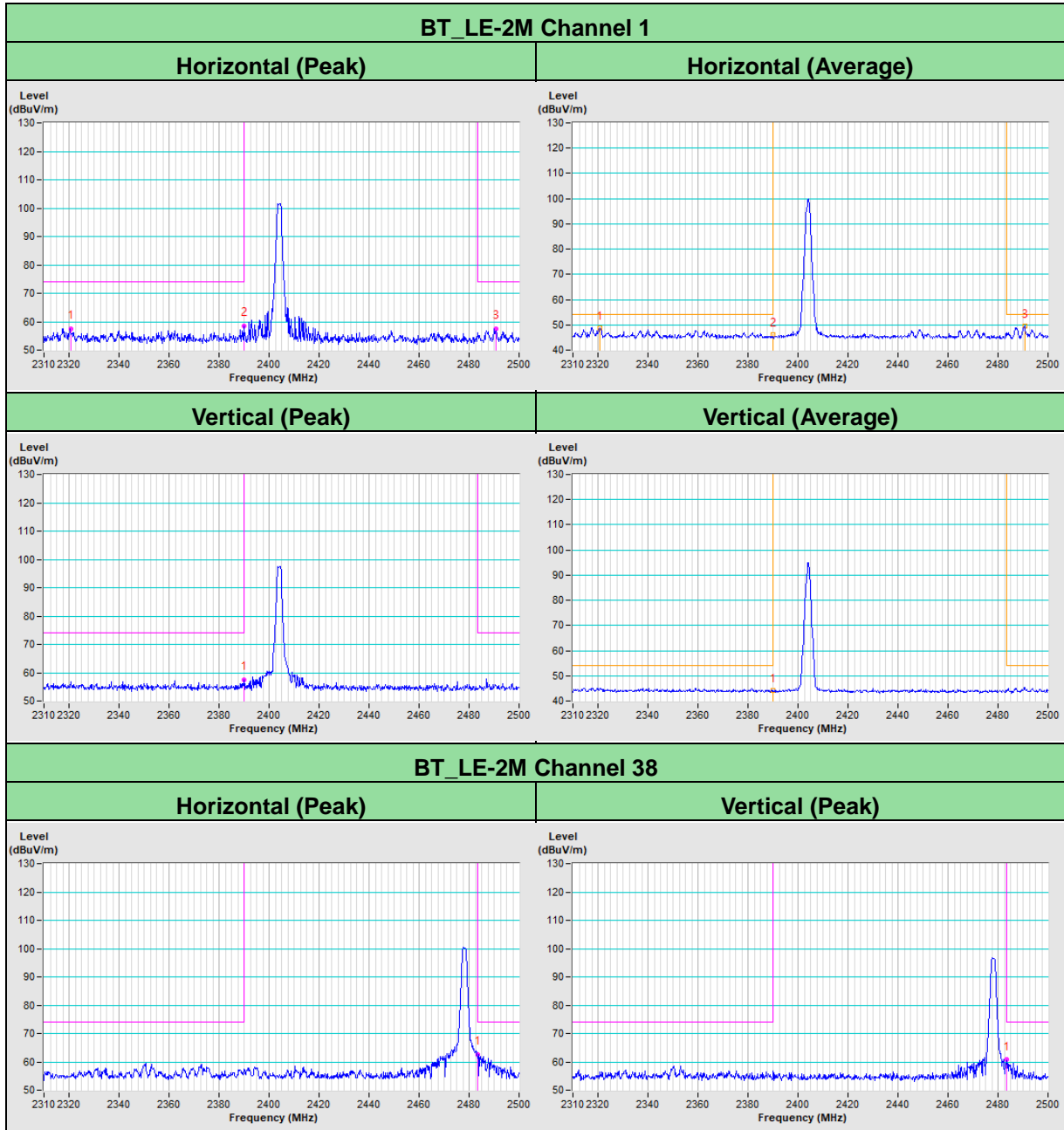

logi bolt function:

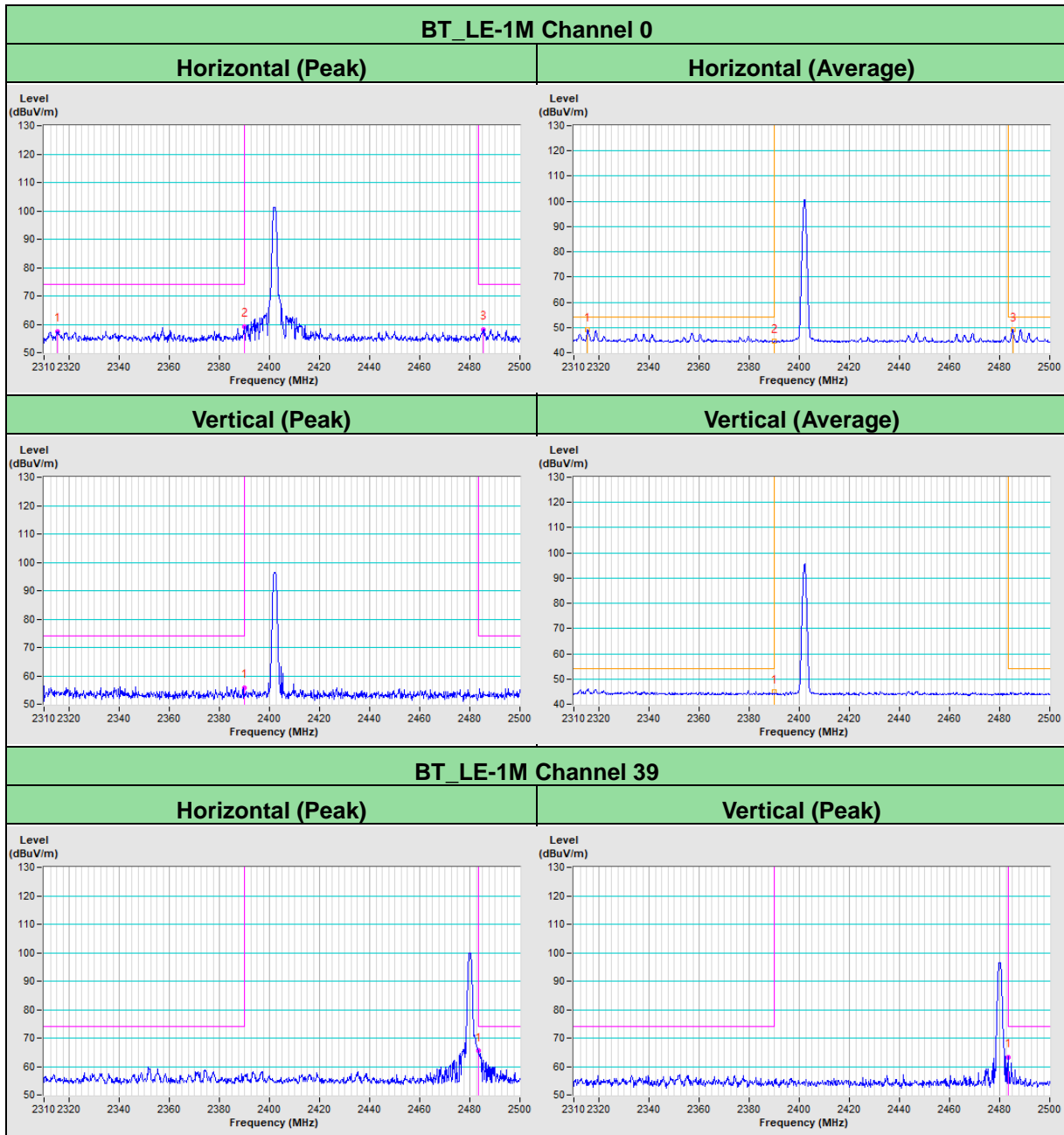

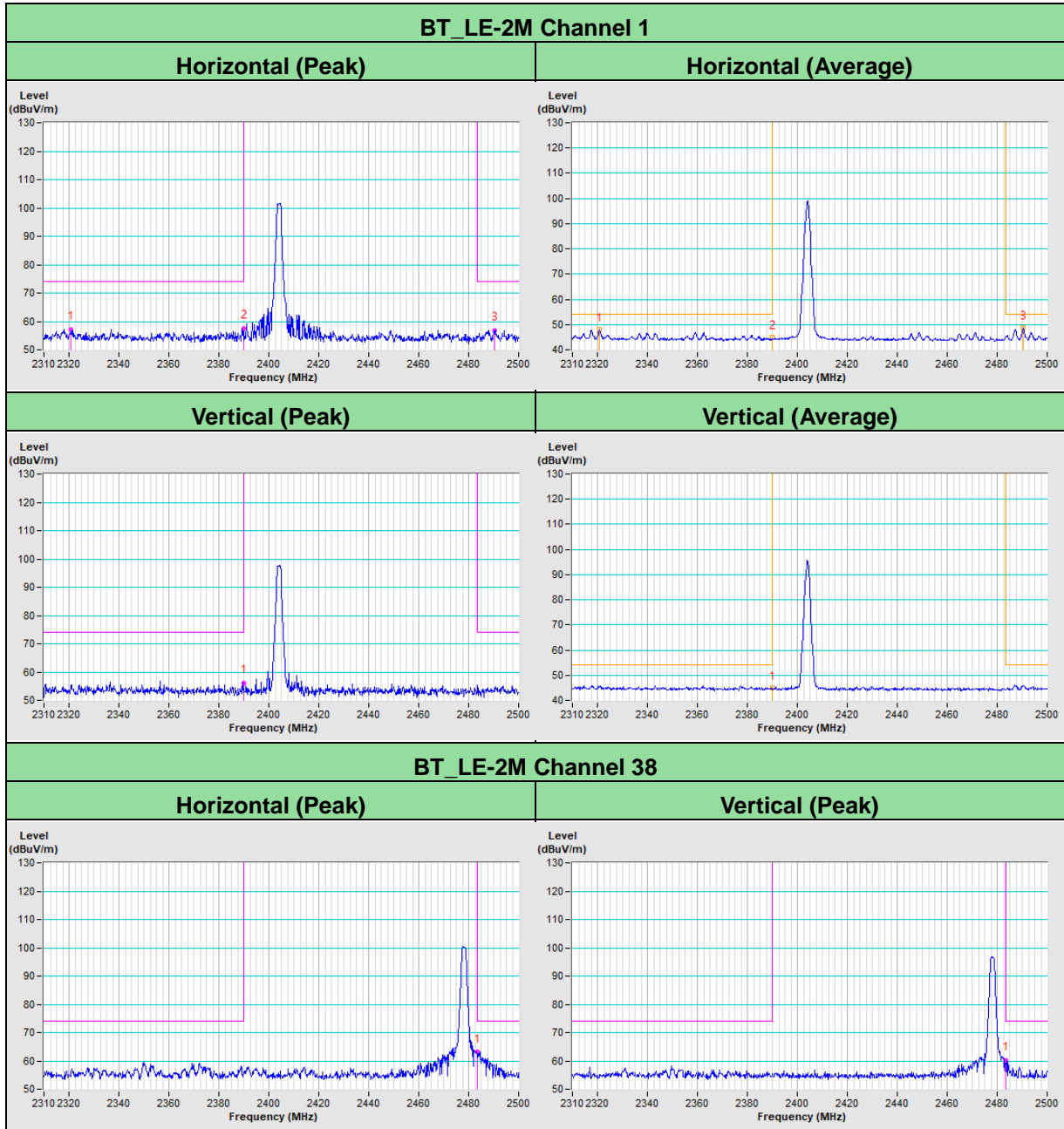

Appendix – Information of the Testing Laboratories

We, Bureau Veritas Consumer Products Services (H.K.) Ltd., Taoyuan Branch, were founded in 1988 to provide our best service in EMC, Radio, Telecom and Safety consultation. Our laboratories are FCC recognized accredited test firms and accredited according to ISO/IEC 17025.

If you have any comments, please feel free to contact us at the following:

Lin Kou EMC/RF Lab

Tel: 886-2-26052180

Fax: 886-2-26051924

Hsin Chu EMC/RF/Telecom Lab

Tel: 886-3-6668565

Fax: 886-3-6668323

Hwa Ya EMC/RF/Safety Lab

Tel: 886-3-3183232

Fax: 886-3-3270892

Email: service.adt@tw.bureauveritas.com

Web Site: www.bureauveritas-adt.com

The address and road map of all our labs can be found in our web site also.

--- END ---