

Supplemental “Transmit Simultaneously” Test Report

Report No.: RFBDKG-WTW-P24030380-3

FCC ID: JNZVR0038

Test Model: VR0038

Received Date: 2024/2/2

Test Date: 2024/4/12 ~ 2024/4/16

Issued Date: 2024/5/16

Applicant: Logitech Far East Ltd.

Address: #2 Creation Rd. 4, Science-Based Ind. Park Hsinchu Taiwan, R.O.C.

Issued By: Bureau Veritas Consumer Products Services (H.K.) Ltd., Taoyuan Branch
Hsin Chu Laboratory

Lab Address: E-2, No.1, Li Hsin 1st Road, Hsinchu Science Park, Hsinchu City 300,
Taiwan

Test Location: E-2, No.1, Li Hsin 1st Road, Hsinchu Science Park, Hsinchu City 300,
Taiwan

**FCC Registration /
Designation Number:** 723255 / TW2022



This report is governed by, and incorporates by reference, the Conditions of Testing as posted at the date of issuance of this report at <http://www.bureauveritas.com/home/about-us/our-business/cps/about-us/terms-conditions/> and is intended for your exclusive use. Any copying or replication of this report to or for any other person or entity, or use of our name or trademark, is permitted only with our prior written permission. This report sets forth our findings solely with respect to the test samples identified herein. The results set forth in this report are not indicative or representative of the quality or characteristics of the lot from which a test sample was taken or any similar or identical product unless specifically and expressly noted. Our report includes all of the tests requested by you and the results thereof based upon the information that you provided to us. Measurement uncertainty is only provided upon request for accredited tests. Statements of conformity are based on simple acceptance criteria without taking measurement uncertainty into account, unless otherwise requested in writing. You have 60 days from date of issuance of this report to notify us of any material error or omission caused by our negligence or if you require measurement uncertainty; provided, however, that such notice shall be in writing and shall specifically address the issue you wish to raise. A failure to raise such issue within the prescribed time shall constitute your unqualified acceptance of the completeness of this report, the tests conducted and the correctness of the report contents.

Table of Contents

| | |
|--|-----------|
| Release Control Record | 3 |
| 1 Certificate of Conformity | 4 |
| 2 Summary of Test Results | 5 |
| 2.1 Measurement Uncertainty | 5 |
| 2.2 Modification Record | 5 |
| 3 General Information | 6 |
| 3.1 General Description of EUT | 6 |
| 3.1.1 Test Mode Applicability and Tested Channel Detail | 8 |
| 3.2 Description of Support Units | 10 |
| 3.2.1 Configuration of System under Test | 11 |
| 4 Test Types and Results | 12 |
| 4.1 Radiated Emission and Bandedge Measurement | 12 |
| 4.1.1 Limits of Radiated Emission and Bandedge Measurement | 12 |
| 4.1.2 Test Instruments | 14 |
| 4.1.3 Test Procedures | 15 |
| 4.1.4 Deviation from Test Standard | 16 |
| 4.1.5 Test Setup | 16 |
| 4.1.6 EUT Operating Conditions | 17 |
| 4.1.7 Test Results | 18 |
| 4.2 Conducted Out of Band Emission Measurement | 27 |
| 4.2.1 Limits of Conducted Out of Band Emission Measurement | 27 |
| 4.2.2 Test Setup | 27 |
| 4.2.3 Test Instruments | 27 |
| 4.2.4 Test Procedures | 27 |
| 4.2.5 Deviation from Test Standard | 27 |
| 4.2.6 EUT Operating Conditions | 27 |
| 4.2.7 Test Results | 27 |
| 5 Pictures of Test Arrangements | 29 |
| Appendix – Information of the Testing Laboratories | 30 |

Release Control Record

| Issue No. | Description | Date Issued |
|------------------------|-------------------|-------------|
| RFBDKG-WTW-P24030380-3 | Original release. | 2024/5/16 |

2 Summary of Test Results

| 47 CFR FCC Part 15, Subpart C, E (SECTION 15.247, 15.407) | | | |
|--|---|--------|--|
| FCC Clause | Test Item | Result | Remarks |
| 15.205 / 15.209 / 15.247(d) 15.407(b) (1/2/3/4(i/ii)/8) | Radiated Emissions and Band Edge Measurement | Pass | Meet the requirement of limit. Minimum passing margin is -4.2 dB at 34.92 MHz & 4874.00 MHz. |

Note:

Determining compliance based on the results of the compliance measurement, not taking into account measurement instrumentation uncertainty.

2.1 Measurement Uncertainty

Where relevant, the following measurement uncertainty levels have been estimated for tests performed on the EUT as specified in CISPR 16-4-2:

| Measurement | Frequency | Expanded Uncertainty (k=2) (\pm) |
|--------------------------------|---------------|---|
| Radiated Emissions up to 1 GHz | 9kHz ~ 30MHz | 3.1 dB |
| | 30MHz ~ 1GHz | 5.5 dB |
| Radiated Emissions above 1 GHz | 1GHz ~ 18GHz | 5.1 dB |
| | 18GHz ~ 40GHz | 5.3 dB |

2.2 Modification Record

There were no modifications required for compliance.

3 General Information

3.1 General Description of EUT

| | |
|-----------------------|--|
| Product | Camera and Speakerphone |
| Brand | Logitech, logi |
| Test Model | VR0038 |
| Status of EUT | Engineering sample |
| Power Supply Rating | 100-240 Vac |
| Modulation Type | WLAN: CCK, DQPSK, DBPSK for DSSS 64QAM, 16QAM, QPSK, BPSK for OFDM 256QAM for OFDM in VHT/11ac mode BT-LE: GFSK |
| Modulation Technology | WLAN: DSSS, OFDM BT-LE: DTS |
| Operating Frequency | WLAN: 2.4GHz: 2.412 ~ 2.462 GHz 5GHz: 5.18 ~ 5.24 GHz, 5.26 ~ 5.32 GHz, 5.50 ~ 5.72 GHz, 5.745 ~ 5.825 GHz BT-LE: 2.402 ~ 2.480 GHz |
| Antenna Type | Refer to Note |
| Antenna Connector | Refer to Note |

Note:

1. The EUT uses following accessories.

| AC Adapter | | |
|---------------------------------|--------------|--|
| Brand | Model | Specification |
| LOGI | AM40R-190A-R | AC Input: 100-240V, 1.4A Max, 50/60Hz DC Output: 19V, 2.11A, 40.09W DC Output Cable: 3m with one core Manufacturer: PHIHONG TECHNOLOGY CO. LTD. |
| USB-C to USB-C Cable | | |
| Brand | Model | Specification |
| logi | 502-001533 | Specification: shielded, 3m |
| USB-C to USB-C Cable (optional) | | |
| Brand | Model | Specification |
| logi | Z00038 | Specification: shielded, 5m |
| C8 Connector(optional) | | |
| Brand | Model | |
| logi | 534-00978 | |

2. There are Bluetooth and WLAN (2.4 GHz & 5 GHz) technology used for the EUT.

3. Simultaneously transmission condition.

| Condition | Technology | |
|-----------|----------------|--------------|
| 1 | WLAN (2.4 GHz) | WLAN (5 GHz) |
| 2 | WLAN (2.4 GHz) | Bluetooth |
| 3 | WLAN (5 GHz) | Bluetooth |

Note: The emission of the simultaneous operation has been evaluated and no non-compliance was found.

4. The antennas provided to the EUT, please refer to the following table:

| Antenna No. | RF Chain No. | Brand | Model | Antenna Gain (dBi) | Frequency range (GHz) | Antenna Type | Connector Type |
|-------------|--------------|---------------|-----------------|--------------------|-----------------------|--------------|----------------|
| WIFI 0 | WF0 | FIH Co., Ltd. | VR0038-0 | 3.6 | 2.4~2.4835 | PIFA | None |
| | | | | 3.24 | 5.15~5.85 | | |
| WIFI 1 | WF1 | FIH Co., Ltd. | VR0038-1 | 3.27 | 2.4~2.4835 | PIFA | None |
| | | | | 3.09 | 5.15~5.85 | | |
| Bluetooth | - | FIH Co., Ltd. | F146D8713910001 | 3.51 | 2.4~2.4835 | PIFA | ipex(MHF) |

5. The EUT incorporates a MIMO function:

| 2.4 GHz Band | | |
|------------------|-----------------------|-----|
| Modulation Mode | TX & RX Configuration | |
| 802.11b | 2TX | 2RX |
| 802.11g | 2TX | 2RX |
| 802.11n (HT20) | 2TX | 2RX |
| 802.11n (HT40) | 2TX | 2RX |
| VHT20 | 2TX | 2RX |
| VHT40 | 2TX | 2RX |
| 5 GHz Band | | |
| Modulation Mode | TX & RX Configuration | |
| 802.11a | 2TX | 2RX |
| 802.11n (HT20) | 2TX | 2RX |
| 802.11n (HT40) | 2TX | 2RX |
| 802.11ac (VHT20) | 2TX | 2RX |
| 802.11ac (VHT40) | 2TX | 2RX |
| 802.11ac (VHT80) | 2TX | 2RX |

6. The above EUT information is declared by manufacturer and for more detailed features description, please refers to the manufacturer's specifications or user's manual.

7. Detail antenna specification please refer to antenna datasheet and/or antenna measurement report.

3.1.1 Test Mode Applicability and Tested Channel Detail

| EUT CONFIGURE MODE | APPLICABLE TO | | | DESCRIPTION |
|--------------------|---------------|-------|----|-------------|
| | RE \geq 1G | RE<1G | OB | |
| - | √ | √ | √ | - |

Where **RE \geq 1G**: Radiated Emission above 1GHz & Bandedge Measurement
RE<1G: Radiated Emission below 1GHz
OB: Conducted Out-Band Emission Measurement

Radiated Emission Test (Above 1GHz):

- The tested configurations represent the worst-case mode from all possible combinations by the maximum power.
- Following channel(s) was (were) selected for the final test as listed below.

| EUT CONFIGURE MODE | MODE | TESTED CHANNEL | MODULATION TECHNOLOGY | MODULATION TYPE |
|--------------------|--|----------------|-----------------------|-----------------|
| 1 | 2.4GHz: 802.11g + 5GHz: 802.11ac (VHT20) | 6 | OFDM | BPSK |
| | | 157 | OFDM | BPSK |
| 2 | 2.4GHz: 802.11g + BT-LE 2M | 6 | OFDM | BPSK |
| | | 39 | DTS | GFSK |
| 3 | 5GHz: 802.11ac (VHT20) + BT-LE 2M | 157 | OFDM | BPSK |
| | | 39 | DTS | GFSK |

Radiated Emission Test (Below 1GHz):

- The tested configurations represent the worst-case mode from all possible combinations by the maximum power.
- Following channel(s) was (were) selected for the final test as listed below.

| EUT CONFIGURE MODE | MODE | TESTED CHANNEL | MODULATION TECHNOLOGY | MODULATION TYPE |
|--------------------|--|----------------|-----------------------|-----------------|
| 1 | 2.4GHz: 802.11g + 5GHz: 802.11ac (VHT20) | 6 | OFDM | BPSK |
| | | 157 | OFDM | BPSK |
| 2 | 2.4GHz: 802.11g + BT-LE 2M | 6 | OFDM | BPSK |
| | | 39 | DTS | GFSK |
| 3 | 5GHz: 802.11ac (VHT20) + BT-LE 2M | 157 | OFDM | BPSK |
| | | 39 | DTS | GFSK |

Conducted Out-Band Emission Measurement:

- The tested configurations represent the worst-case mode from all possible combinations by the maximum power.
- Following channel(s) was (were) selected for the final test as listed below.

| EUT CONFIGURE MODE | MODE | TESTED CHANNEL | MODULATION TECHNOLOGY | MODULATION TYPE |
|--------------------|--|----------------|-----------------------|-----------------|
| 1 | 2.4GHz: 802.11g + 5GHz: 802.11ac (VHT20) | 6 | OFDM | BPSK |
| | | 157 | OFDM | BPSK |

Test Condition:

| Applicable To | Environmental Conditions | Input Power | Tested By |
|---------------|--------------------------|--------------|-----------|
| RE \geq 1G | 25deg. C, 75%RH | 120Vac, 60Hz | Weiwei Lo |
| RE<1G | 25deg. C, 75%RH | 120Vac, 60Hz | Weiwei Lo |
| OB | 24deg. C, 62%RH | 120Vac, 60Hz | John Peng |

3.2 Description of Support Units

The EUT has been tested as an independent unit together with other necessary accessories or support units. The following support units or accessories were used to form a representative test configuration during the tests.

| ID | Product | Brand | Model No. | Serial No. | FCC ID | Remarks |
|----|-------------------|----------|----------------|----------------------------------|--------|-----------------------|
| A | Monitor | DELL | P2415Q | CN-0J1P7F-QDC00-85L-13 GB-A09 | DoC | Provided by Lab |
| B | Laptop | Lenovo | 20U5S01X00 L14 | PF-1ANPYA | N/A | Provided by Lab |
| C | Remote controller | Logitech | RR0016 | N/A | N/A | Supplied by applicant |
| D | Router | NETGEAR | RAX40 | N/A | N/A | Provided by Lab |
| E | Laptop | Lenovo | 20U5S01X00 L14 | PF-28LKK7 | N/A | Provided by Lab |

| ID | Cable Descriptions | Qty. | Length (m) | Shielding (Yes/No) | Cores (Qty.) | Remarks |
|----|--------------------|------|------------|--------------------|--------------|-----------------------|
| 1 | HDMI Cable | 1 | 2 | Yes | 0 | Supplied by applicant |
| 2 | HDMI Cable | 1 | 2 | Yes | 0 | Provided by Lab |
| 3 | USB-C Cable | 1 | 3 | Yes | 0 | Supplied by applicant |
| 4 | DC Cable | 1 | 3 | No | 1 | Supplied by applicant |
| 5 | RJ-45 Cable | 1 | 10 | No | 0 | Provided by Lab |
| 6 | RJ-45 Cable | 1 | 3 | No | 0 | Provided by Lab |

3.2.1 Configuration of System under Test

For Radiated Emission test

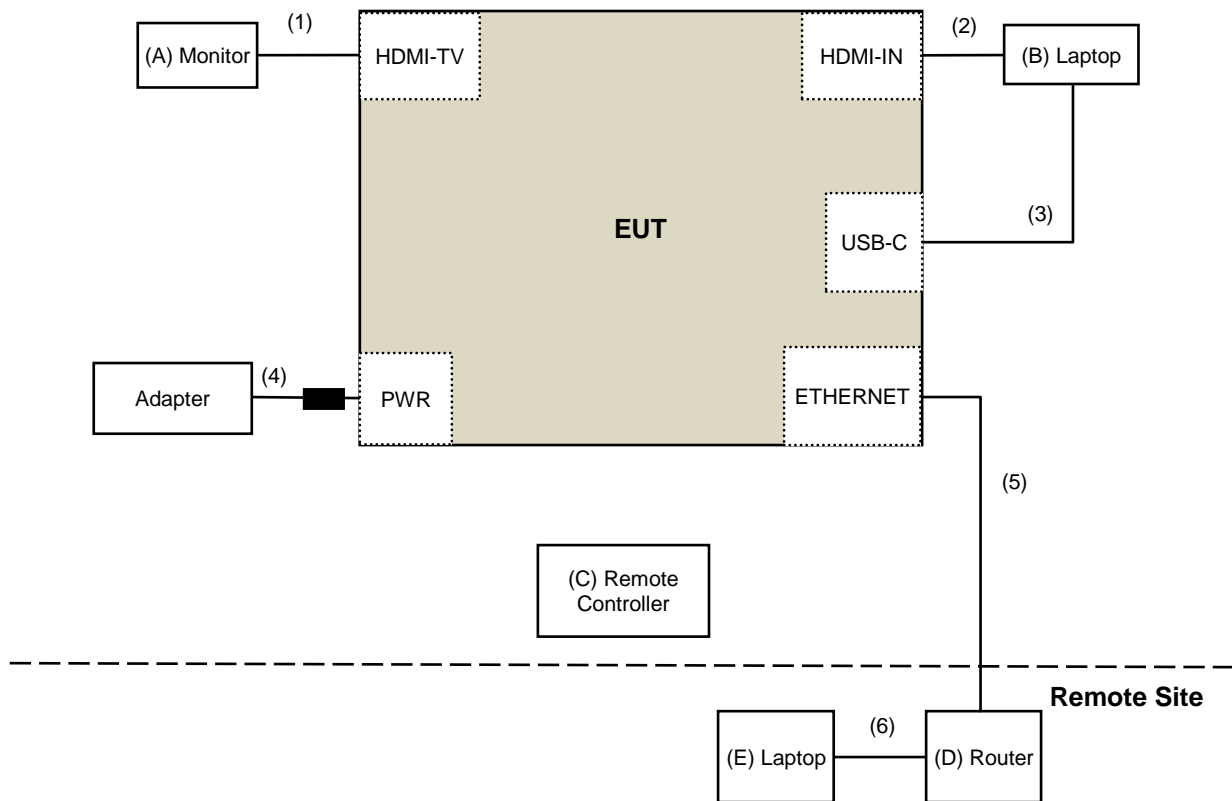

4 Test Types and Results

4.1 Radiated Emission and Bandedge Measurement

4.1.1 Limits of Radiated Emission and Bandedge Measurement

Radiated emissions which fall in the restricted bands must comply with the radiated emission limits specified as below table.

| Frequencies (MHz) | Field Strength (microvolts/meter) | Measurement Distance (meters) |
|-------------------|-----------------------------------|-------------------------------|
| 0.009 ~ 0.490 | 2400/F(kHz) | 300 |
| 0.490 ~ 1.705 | 24000/F(kHz) | 30 |
| 1.705 ~ 30.0 | 30 | 30 |
| 30 ~ 88 | 100 | 3 |
| 88 ~ 216 | 150 | 3 |
| 216 ~ 960 | 200 | 3 |
| Above 960 | 500 | 3 |

Note:

1. The lower limit shall apply at the transition frequencies.
2. Emission level (dBuV/m) = 20 log Emission level (uV/m).
3. For frequencies above 1000MHz, the field strength limits are based on average detector, however, the peak field strength of any emission shall not exceed the maximum permitted average limits, specified above by more than 20dB under any condition of modulation.

Limits of unwanted emission out of the restricted bands

| Applicable To | | Limit | |
|---|-----------------|--|---|
| 789033 D02 General UNII Test Procedure New Rules v02r01 | | Field Strength at 3m | |
| | | PK:74 (dBμV/m) | AV:54 (dBμV/m) |
| Frequency Band | Applicable To | EIRP Limit | Equivalent Field Strength at 3m |
| 5150~5250 MHz | 15.407(b)(1) | PK:-27 (dBm/MHz) | PK:68.2(dBμV/m) |
| 5250~5350 MHz | 15.407(b)(2) | | |
| 5470~5725 MHz | 15.407(b)(3) | | |
| 5725~5850 MHz | 15.407(b)(4)(i) | PK: -27 (dBm/MHz) ^{*1} PK: 10 (dBm/MHz) ^{*2} PK: 15.6 (dBm/MHz) ^{*3} PK: 27 (dBm/MHz) ^{*4} | PK: 68.2(dBμV/m) ^{*1} PK: 105.2 (dBμV/m) ^{*2} PK: 110.8(dBμV/m) ^{*3} PK: 122.2 (dBμV/m) ^{*4} |
| 5725~5850 MHz | 15.407(b)(4)(i) | PK: -27 (dBm/MHz) ^{*1} PK: 10 (dBm/MHz) ^{*2} PK: 15.6 (dBm/MHz) ^{*3} PK: 27 (dBm/MHz) ^{*4} | PK: 68.2(dBμV/m) ^{*1} PK: 105.2 (dBμV/m) ^{*2} PK: 110.8(dBμV/m) ^{*3} PK: 122.2 (dBμV/m) ^{*4} |
| ^{*1} beyond 75 MHz or more above of the band edge. ^{*3} below the band edge increasing linearly to a level of 15.6 dBm/MHz at 5 MHz above. | | ^{*2} below the band edge increasing linearly to 10 dBm/MHz at 25 MHz above. ^{*4} from 5 MHz above or below the band edge increasing linearly to a level of 27 dBm/MHz at the band edge. | |

Note:

The following formula is used to convert the equipment isotropic radiated power (eirp) to field strength:

$$E = \frac{1000000\sqrt{30P}}{3} \mu\text{V/m, where P is the eirp (Watts).}$$

4.1.2 Test Instruments

For Radiated emission test:

| Description Manufacturer | Model No. | Serial No. | Calibrated Date | Calibrated Until |
|---|----------------------|-------------|------------------------|------------------------|
| Antenna Tower & Turn Table Max-Full | MF-7802 | MF780208406 | N/A | N/A |
| Fix tool for Boresight antenna tower BV | FBA-01 | FBA_SIP01 | N/A | N/A |
| Horn Antenna Schwarzbeck | BBHA 9120D | 9120D-406 | 2023/11/12 | 2024/11/11 |
| | BBHA 9170 | 9170-739 | 2023/11/12 | 2024/11/11 |
| MXE EMI Receiver Agilent | N9038A | MY50010156 | 2023/6/13 | 2024/6/12 |
| Preamplifier EMCI | EMC12630SE | 980384 | 2023/8/9 2024/1/29 | 2024/8/8 2025/1/28 |
| | EMC184045SE | 980387 | 2023/8/9 | 2024/8/8 |
| MXA Signal Analyzer Keysight | N9020B | MY60112410 | 2024/3/13 | 2025/3/12 |
| RF Coaxial Cable EMCI | EMC102-KM-KM-1200 | 160924 | 2023/8/9 2024/1/29 | 2024/8/8 2025/1/28 |
| | EMC102-KM-KM-4000 | 200214 | 2023/2/20 2024/1/29 | 2024/2/19 2025/1/28 |
| | EMC104-SM-SM-1500 | 180504 | 2023/3/27 2024/1/29 | 2024/3/26 2025/1/28 |
| | EMC104-SM-SM-2000 | 180601 | 2023/6/2 2024/1/29 | 2024/6/1 2025/1/28 |
| | EMC104-SM-SM-6000 | 210201 | 2023/5/8 2024/1/29 | 2024/5/7 2025/1/28 |
| Software | ADT_Radiated_V8.7.08 | N/A | N/A | N/A |

Notes:

1. The test was performed in 966 Chamber No. 3.
2. Tested Date: 2024/4/12 ~ 2024/4/15

For other test items:

| Description Manufacturer | Model No. | Serial No. | Calibrated Date | Calibrated Until |
|---------------------------------|----------------------------------|------------|--------------------|---------------------|
| MXA Signal Analyzer Keysight | N9020B | MY60112410 | 2024/3/13 | 2025/3/12 |
| Software | ADT_RF Test Software V7.6.5.4 | N/A | N/A | N/A |

Notes:

1. The test was performed in Oven room 2.
2. Tested Date: 2024/4/16

4.1.3 Test Procedures

For Radiated emission below 30MHz

- a. The EUT was placed on the top of a rotating table 0.8 meters above the ground at a 3 meter chamber room. The table was rotated 360 degrees to determine the position of the highest radiation.
- b. The EUT was set 3 meters away from the interference-receiving antenna, which was mounted on the top of a variable-height antenna tower.
- c. Parallel, perpendicular, and ground-parallel orientations of the antenna are set to make the measurement.
- d. For each suspected emission, the EUT was arranged to its worst case and the rotatable table was turned from 0 degrees to 360 degrees to find the maximum reading.
- e. The test-receiver system was set to Quasi-Peak Detect Function and Specified Bandwidth with Maximum Hold Mode.

Note:

1. The resolution bandwidth and video bandwidth of test receiver/spectrum analyzer is 9kHz at frequency below 30MHz.

For Radiated emission above 30MHz

- a. The EUT was placed on the top of a rotating table 0.8 meters (for 30MHz ~ 1GHz) / 1.5 meters (for above 1GHz) above the ground at 3 meter chamber room for test. The table was rotated 360 degrees to determine the position of the highest radiation.
- b. The EUT was set 3 meters away from the interference-receiving antenna, which was mounted on the top of a variable-height antenna tower.
- c. The height of antenna is varied from one meter to four meters above the ground to determine the maximum value of the field strength. Both horizontal and vertical polarizations of the antenna are set to make the measurement.
- d. For each suspected emission, the EUT was arranged to its worst case and then the antenna was tuned to heights from 1 meter to 4 meters and the rotatable table was turned from 0 degrees to 360 degrees to find the maximum reading.
- e. The test-receiver system was set to quasi-peak detect function and specified bandwidth with maximum hold mode when the test frequency is below 1 GHz.
- f. The test-receiver system was set to peak and average detect function and specified bandwidth with maximum hold mode when the test frequency is above 1 GHz. If the peak reading value also meets average limit, measurement with the average detector is unnecessary.

Note:

1. The resolution bandwidth and video bandwidth of test receiver/spectrum analyzer is 120kHz for Quasi-peak detection (QP) at frequency below 1GHz.
2. The resolution bandwidth of test receiver/spectrum analyzer is 1 MHz and the video bandwidth is 3 MHz for Peak detection (PK) at frequency above 1GHz.
3. The resolution bandwidth of test receiver/spectrum analyzer is 1MHz and the video bandwidth is $\geq 1/T$ (Duty cycle < 98%) or 10Hz (Duty cycle $\geq 98\%$) for Average detection (AV) at frequency above 1GHz.
4. All modes of operation were investigated and the worst-case emissions are reported.

4.1.4 Deviation from Test Standard

No deviation.

4.1.5 Test Setup

For Radiated emission below 30MHz

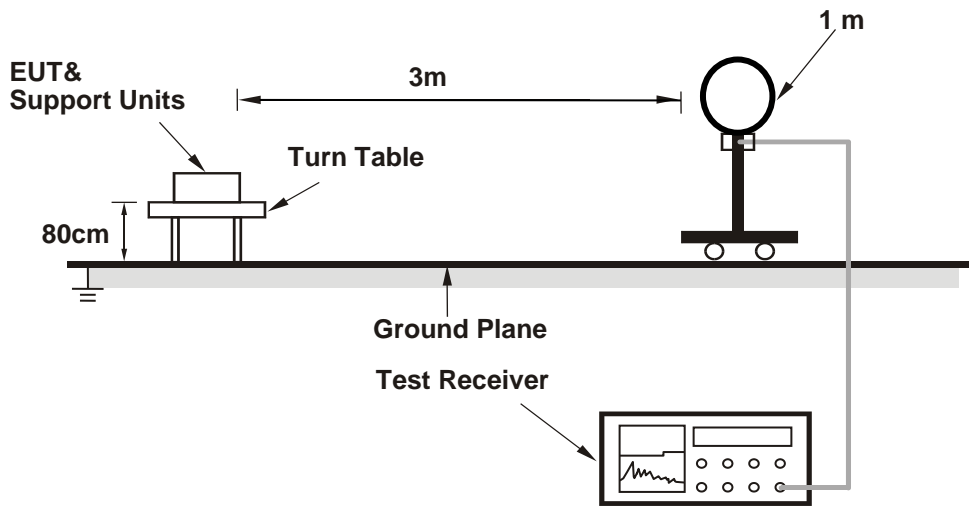

For Radiated emission 30MHz to 1GHz

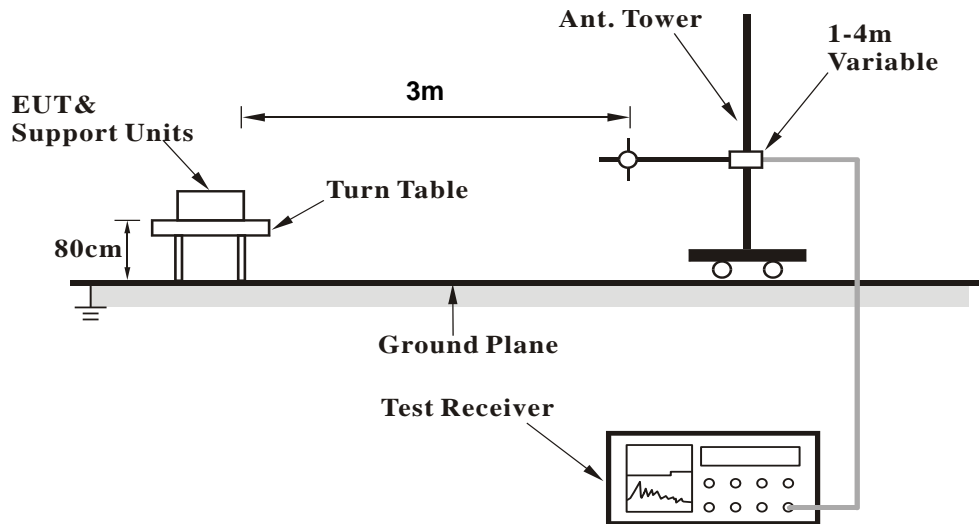

For Radiated emission above 1GHz

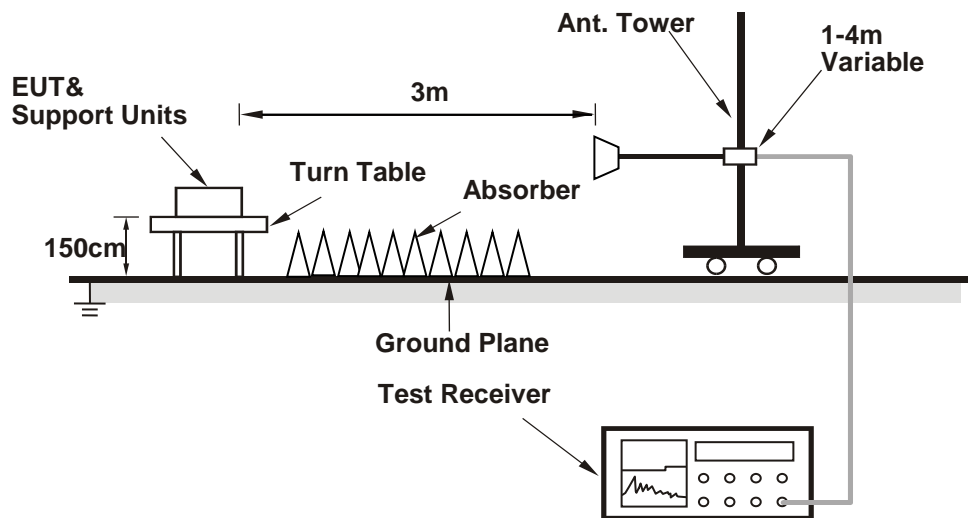

For the actual test configuration, please refer to the attached file (Test Setup Photo).

4.1.6 EUT Operating Conditions

- a. Placed the EUT on the testing table.
- b. Controlling software (adb paste WIFI/BT Command)) has been activated to set the EUT under transmission condition continuously at specific channel frequency.

4.1.7 Test Results

Above 1GHz Data:

Mode 1

| | | | |
|-----------------|--------------|-------------------|---------------------------|
| Frequency Range | 1GHz ~ 40GHz | Detector Function | Peak (PK) Average (AV) |
|-----------------|--------------|-------------------|---------------------------|

| Antenna Polarity & Test Distance : Horizontal at 3 m | | | | | | | | |
|--|-----------------|-------------------------|----------------|-------------|--------------------|----------------------|------------------|--------------------------|
| No | Frequency (MHz) | Emission Level (dBuV/m) | Limit (dBuV/m) | Margin (dB) | Antenna Height (m) | Table Angle (Degree) | Raw Value (dBuV) | Correction Factor (dB/m) |
| 1 | 4874.00 | 51.2 PK | 74.0 | -22.8 | 2.33 H | 155 | 48.7 | 2.5 |
| 2 | 4874.00 | 49.8 AV | 54.0 | -4.2 | 2.33 H | 155 | 47.3 | 2.5 |
| 3 | 7311.00 | 44.9 PK | 74.0 | -29.1 | 2.14 H | 253 | 36.2 | 8.7 |
| 4 | 7311.00 | 33.2 AV | 54.0 | -20.8 | 2.14 H | 253 | 24.5 | 8.7 |
| 5 | 11570.00 | 59.1 PK | 74.0 | -14.9 | 1.91 H | 205 | 43.9 | 15.2 |
| 6 | 11570.00 | 44.9 AV | 54.0 | -9.1 | 1.91 H | 205 | 29.7 | 15.2 |
| 7 | 17355.00 | 60.0 PK | 68.2 | -8.2 | 1.52 H | 190 | 41.5 | 18.5 |
| Antenna Polarity & Test Distance : Vertical at 3 m | | | | | | | | |
| No | Frequency (MHz) | Emission Level (dBuV/m) | Limit (dBuV/m) | Margin (dB) | Antenna Height (m) | Table Angle (Degree) | Raw Value (dBuV) | Correction Factor (dB/m) |
| 1 | 4874.00 | 47.9 PK | 74.0 | -26.1 | 2.76 V | 175 | 45.4 | 2.5 |
| 2 | 4874.00 | 45.4 AV | 54.0 | -8.6 | 2.76 V | 175 | 42.9 | 2.5 |
| 3 | 7311.00 | 41.6 PK | 74.0 | -32.4 | 1.58 V | 51 | 32.9 | 8.7 |
| 4 | 7311.00 | 30.2 AV | 54.0 | -23.8 | 1.58 V | 51 | 21.5 | 8.7 |
| 5 | 11570.00 | 55.9 PK | 74.0 | -18.1 | 2.35 V | 135 | 40.7 | 15.2 |
| 6 | 11570.00 | 44.5 AV | 54.0 | -9.5 | 2.35 V | 135 | 29.3 | 15.2 |
| 7 | 17355.00 | 58.7 PK | 68.2 | -9.5 | 1.62 V | 147 | 40.2 | 18.5 |

Remarks:

1. Emission Level(dBuV/m) = Raw Value(dBuV) + Correction Factor(dB/m)
2. Correction Factor(dB/m) = Antenna Factor(dB/m) + Cable Factor(dB) – Pre-Amplifier Factor(dB)
3. Margin value = Emission Level – Limit value
4. The other emission levels were very low against the limit.
5. " # ": The radiated frequency is out of the restricted band.

Mode 2

| | | | |
|------------------------|--------------|--------------------------|---------------------------|
| Frequency Range | 1GHz ~ 25GHz | Detector Function | Peak (PK) Average (AV) |
|------------------------|--------------|--------------------------|---------------------------|

Antenna Polarity & Test Distance : Horizontal at 3 m

| No | Frequency (MHz) | Emission Level (dBuV/m) | Limit (dBuV/m) | Margin (dB) | Antenna Height (m) | Table Angle (Degree) | Raw Value (dBuV) | Correction Factor (dB/m) |
|----|-----------------|-------------------------|----------------|-------------|--------------------|----------------------|------------------|--------------------------|
| 1 | 4874.00 | 51.7 PK | 74.0 | -22.3 | 2.37 H | 139 | 48.9 | 2.8 |
| 2 | 4874.00 | 49.3 AV | 54.0 | -4.7 | 2.37 H | 139 | 46.5 | 2.8 |
| 3 | 4960.00 | 38.5 PK | 74.0 | -35.5 | 2.08 H | 185 | 35.5 | 3.0 |
| 4 | 4960.00 | 27.5 AV | 54.0 | -26.5 | 2.08 H | 185 | 24.5 | 3.0 |
| 5 | 7311.00 | 45.0 PK | 74.0 | -29.0 | 2.20 H | 214 | 35.9 | 9.1 |
| 6 | 7311.00 | 33.2 AV | 54.0 | -20.8 | 2.20 H | 214 | 24.1 | 9.1 |
| 7 | 7440.00 | 40.8 PK | 74.0 | -33.2 | 2.77 H | 259 | 31.2 | 9.6 |
| 8 | 7440.00 | 30.5 AV | 54.0 | -23.5 | 2.77 H | 259 | 20.9 | 9.6 |

Antenna Polarity & Test Distance : Vertical at 3 m

| No | Frequency (MHz) | Emission Level (dBuV/m) | Limit (dBuV/m) | Margin (dB) | Antenna Height (m) | Table Angle (Degree) | Raw Value (dBuV) | Correction Factor (dB/m) |
|----|-----------------|-------------------------|----------------|-------------|--------------------|----------------------|------------------|--------------------------|
| 1 | 4874.00 | 47.8 PK | 74.0 | -26.2 | 2.93 V | 192 | 45.0 | 2.8 |
| 2 | 4874.00 | 45.7 AV | 54.0 | -8.3 | 2.93 V | 192 | 42.9 | 2.8 |
| 3 | 4960.00 | 39.8 PK | 74.0 | -34.2 | 2.65 V | 112 | 36.8 | 3.0 |
| 4 | 4960.00 | 29.0 AV | 54.0 | -25.0 | 2.65 V | 112 | 26.0 | 3.0 |
| 5 | 7311.00 | 43.3 PK | 74.0 | -30.7 | 1.39 V | 109 | 34.2 | 9.1 |
| 6 | 7311.00 | 32.1 AV | 54.0 | -21.9 | 1.39 V | 109 | 23.0 | 9.1 |
| 7 | 7440.00 | 39.4 PK | 74.0 | -34.6 | 2.87 V | 136 | 29.8 | 9.6 |
| 8 | 7440.00 | 27.8 AV | 54.0 | -26.2 | 2.87 V | 136 | 18.2 | 9.6 |

Remarks:

1. Emission Level(dBuV/m) = Raw Value(dBuV) + Correction Factor(dB/m)
2. Correction Factor(dB/m) = Antenna Factor(dB/m) + Cable Factor(dB) – Pre-Amplifier Factor(dB)
3. Margin value = Emission Level – Limit value
4. The other emission levels were very low against the limit.
5. " # ": The radiated frequency is out of the restricted band.

Mode 3

| | | | |
|------------------------|--------------|--------------------------|---------------------------|
| Frequency Range | 1GHz ~ 40GHz | Detector Function | Peak (PK) Average (AV) |
|------------------------|--------------|--------------------------|---------------------------|

Antenna Polarity & Test Distance : Horizontal at 3 m

| No | Frequency (MHz) | Emission Level (dBuV/m) | Limit (dBuV/m) | Margin (dB) | Antenna Height (m) | Table Angle (Degree) | Raw Value (dBuV) | Correction Factor (dB/m) |
|----|-----------------|-------------------------|----------------|-------------|--------------------|----------------------|------------------|--------------------------|
| 1 | 4960.00 | 38.1 PK | 74.0 | -35.9 | 2.24 H | 226 | 35.4 | 2.7 |
| 2 | 4960.00 | 27.2 AV | 54.0 | -26.8 | 2.24 H | 226 | 24.5 | 2.7 |
| 3 | 7440.00 | 38.6 PK | 74.0 | -35.4 | 2.74 H | 213 | 29.3 | 9.3 |
| 4 | 7440.00 | 28.6 AV | 54.0 | -25.4 | 2.74 H | 213 | 19.3 | 9.3 |
| 5 | 11570.00 | 59.4 PK | 74.0 | -14.6 | 1.84 H | 198 | 44.2 | 15.2 |
| 6 | 11570.00 | 44.8 AV | 54.0 | -9.2 | 1.84 H | 198 | 29.6 | 15.2 |
| 7 | 17355.00 | 59.2 PK | 68.2 | -9.0 | 1.33 H | 177 | 40.7 | 18.5 |

Antenna Polarity & Test Distance : Vertical at 3 m

| No | Frequency (MHz) | Emission Level (dBuV/m) | Limit (dBuV/m) | Margin (dB) | Antenna Height (m) | Table Angle (Degree) | Raw Value (dBuV) | Correction Factor (dB/m) |
|----|-----------------|-------------------------|----------------|-------------|--------------------|----------------------|------------------|--------------------------|
| 1 | 4960.00 | 38.8 PK | 74.0 | -35.2 | 2.66 V | 128 | 36.1 | 2.7 |
| 2 | 4960.00 | 28.3 AV | 54.0 | -25.7 | 2.66 V | 128 | 25.6 | 2.7 |
| 3 | 7440.00 | 38.7 PK | 74.0 | -35.3 | 2.83 V | 128 | 29.4 | 9.3 |
| 4 | 7440.00 | 27.8 AV | 54.0 | -26.2 | 2.83 V | 128 | 18.5 | 9.3 |
| 5 | 11570.00 | 57.2 PK | 74.0 | -16.8 | 2.24 V | 137 | 42.0 | 15.2 |
| 6 | 11570.00 | 45.0 AV | 54.0 | -9.0 | 2.24 V | 137 | 29.8 | 15.2 |
| 7 | 17355.00 | 59.6 PK | 68.2 | -8.6 | 1.70 V | 140 | 41.1 | 18.5 |

Remarks:

1. Emission Level(dBuV/m) = Raw Value(dBuV) + Correction Factor(dB/m)
2. Correction Factor(dB/m) = Antenna Factor(dB/m) + Cable Factor(dB) – Pre-Amplifier Factor(dB)
3. Margin value = Emission Level – Limit value
4. The other emission levels were very low against the limit.
5. " # ": The radiated frequency is out of the restricted band.

Below 1GHz Data:
Mode 1

| | | | |
|------------------------|--------------|--------------------------|-----------------|
| Frequency Range | 30MHz ~ 1GHz | Detector Function | Quasi-Peak (QP) |
|------------------------|--------------|--------------------------|-----------------|

| Antenna Polarity & Test Distance : Horizontal at 3 m | | | | | | | | |
|--|-----------------|-------------------------|----------------|-------------|--------------------|----------------------|------------------|--------------------------|
| No | Frequency (MHz) | Emission Level (dBuV/m) | Limit (dBuV/m) | Margin (dB) | Antenna Height (m) | Table Angle (Degree) | Raw Value (dBuV) | Correction Factor (dB/m) |
| 1 | 94.30 | 34.7 QP | 43.5 | -8.8 | 2.00 H | 122 | 53.0 | -18.3 |
| 2 | 137.77 | 28.7 QP | 43.5 | -14.8 | 1.50 H | 249 | 42.1 | -13.4 |
| 3 | 305.30 | 35.5 QP | 46.0 | -10.5 | 1.50 H | 150 | 47.6 | -12.1 |
| 4 | 406.26 | 31.9 QP | 46.0 | -14.1 | 2.00 H | 116 | 41.6 | -9.7 |
| 5 | 499.96 | 32.5 QP | 46.0 | -13.5 | 1.00 H | 323 | 40.1 | -7.6 |
| 6 | 625.38 | 30.6 QP | 46.0 | -15.4 | 3.00 H | 39 | 35.3 | -4.7 |

Remarks:

1. Emission Level(dBuV/m) = Raw Value(dBuV) + Correction Factor(dB/m)
2. Correction Factor(dB/m) = Antenna Factor(dB/m) + Cable Factor(dB) – Pre-Amplifier Factor(dB)
3. Margin value = Emission Level – Limit value
4. The other emission levels were very low against the limit of frequency range 30 MHz ~ 1 GHz.
5. The frequency range 9 kHz ~ 30 MHz: all emissions are more than 20 dB below the limit, therefore do not be recorded in this report.

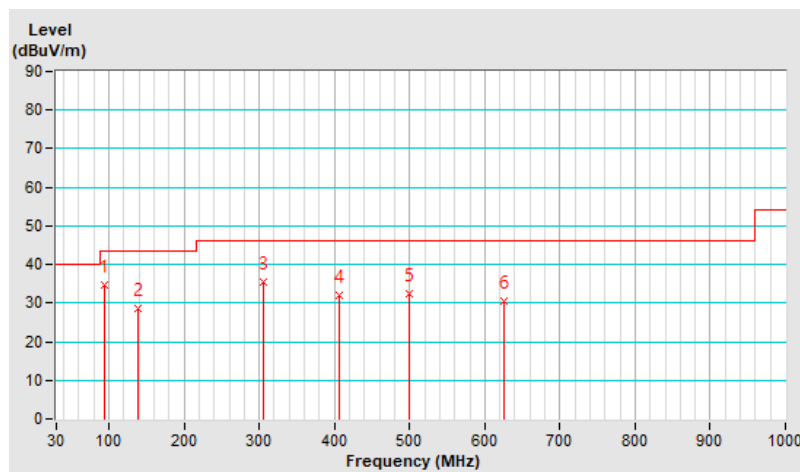

| | | | |
|-----------------|--------------|-------------------|-----------------|
| Frequency Range | 30MHz ~ 1GHz | Detector Function | Quasi-Peak (QP) |
|-----------------|--------------|-------------------|-----------------|

| Antenna Polarity & Test Distance : Vertical at 3 m | | | | | | | | |
|--|-----------------|-------------------------|----------------|-------------|--------------------|----------------------|------------------|--------------------------|
| No | Frequency (MHz) | Emission Level (dBuV/m) | Limit (dBuV/m) | Margin (dB) | Antenna Height (m) | Table Angle (Degree) | Raw Value (dBuV) | Correction Factor (dB/m) |
| 1 | 34.92 | 35.8 QP | 40.0 | -4.2 | 1.50 V | 200 | 49.5 | -13.7 |
| 2 | 91.48 | 35.8 QP | 43.5 | -7.7 | 2.00 V | 339 | 54.4 | -18.6 |
| 3 | 138.79 | 32.0 QP | 43.5 | -11.5 | 1.50 V | 225 | 45.4 | -13.4 |
| 4 | 304.81 | 31.2 QP | 46.0 | -14.8 | 1.00 V | 78 | 43.3 | -12.1 |
| 5 | 500.45 | 33.0 QP | 46.0 | -13.0 | 1.50 V | 184 | 40.6 | -7.6 |
| 6 | 896.90 | 38.6 QP | 46.0 | -7.4 | 1.00 V | 317 | 39.3 | -0.7 |

Remarks:

1. Emission Level(dBuV/m) = Raw Value(dBuV) + Correction Factor(dB/m)
2. Correction Factor(dB/m) = Antenna Factor(dB/m) + Cable Factor(dB) – Pre-Amplifier Factor(dB)
3. Margin value = Emission Level – Limit value
4. The other emission levels were very low against the limit of frequency range 30 MHz ~ 1 GHz.
5. The frequency range 9 kHz ~ 30 MHz: all emissions are more than 20 dB below the limit, therefore do not be recorded in this report.

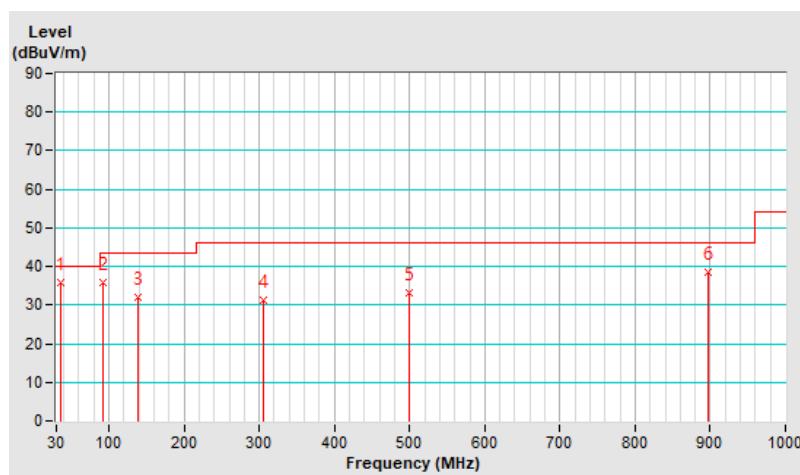

Mode 2

| | | | |
|------------------------|--------------|--------------------------|-----------------|
| Frequency Range | 30MHz ~ 1GHz | Detector Function | Quasi-Peak (QP) |
|------------------------|--------------|--------------------------|-----------------|

Antenna Polarity & Test Distance : Horizontal at 3 m

| No | Frequency (MHz) | Emission Level (dBuV/m) | Limit (dBuV/m) | Margin (dB) | Antenna Height (m) | Table Angle (Degree) | Raw Value (dBuV) | Correction Factor (dB/m) |
|----|-----------------|-------------------------|----------------|-------------|--------------------|----------------------|------------------|--------------------------|
| 1 | 94.41 | 35.0 QP | 43.5 | -8.5 | 2.00 H | 122 | 53.3 | -18.3 |
| 2 | 137.66 | 28.3 QP | 43.5 | -15.2 | 1.00 H | 242 | 41.7 | -13.4 |
| 3 | 305.06 | 35.2 QP | 46.0 | -10.8 | 1.50 H | 166 | 47.3 | -12.1 |
| 4 | 406.48 | 32.4 QP | 46.0 | -13.6 | 2.00 H | 109 | 42.1 | -9.7 |
| 5 | 500.54 | 33.0 QP | 46.0 | -13.0 | 2.00 H | 307 | 40.6 | -7.6 |
| 6 | 626.04 | 31.2 QP | 46.0 | -14.8 | 3.00 H | 41 | 35.9 | -4.7 |

Remarks:

1. Emission Level(dBuV/m) = Raw Value(dBuV) + Correction Factor(dB/m)
2. Correction Factor(dB/m) = Antenna Factor(dB/m) + Cable Factor(dB) – Pre-Amplifier Factor(dB)
3. Margin value = Emission Level – Limit value
4. The other emission levels were very low against the limit of frequency range 30 MHz ~ 1 GHz.
5. The frequency range 9 kHz ~ 30 MHz: all emissions are more than 20 dB below the limit, therefore do not be recorded in this report.

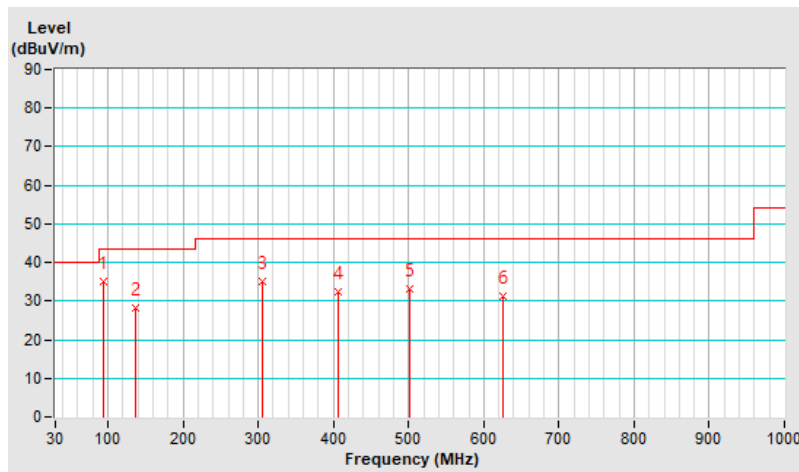

| | | | |
|-----------------|--------------|-------------------|-----------------|
| Frequency Range | 30MHz ~ 1GHz | Detector Function | Quasi-Peak (QP) |
|-----------------|--------------|-------------------|-----------------|

| Antenna Polarity & Test Distance : Vertical at 3 m | | | | | | | | |
|--|-----------------|-------------------------|----------------|-------------|--------------------|----------------------|------------------|--------------------------|
| No | Frequency (MHz) | Emission Level (dBuV/m) | Limit (dBuV/m) | Margin (dB) | Antenna Height (m) | Table Angle (Degree) | Raw Value (dBuV) | Correction Factor (dB/m) |
| 1 | 34.71 | 35.4 QP | 40.0 | -4.6 | 1.50 V | 215 | 49.1 | -13.7 |
| 2 | 91.45 | 35.8 QP | 43.5 | -7.7 | 2.00 V | 339 | 54.4 | -18.6 |
| 3 | 139.18 | 32.4 QP | 43.5 | -11.1 | 1.50 V | 236 | 45.8 | -13.4 |
| 4 | 305.21 | 31.6 QP | 46.0 | -14.4 | 1.00 V | 90 | 43.7 | -12.1 |
| 5 | 500.40 | 32.8 QP | 46.0 | -13.2 | 1.00 V | 181 | 40.4 | -7.6 |
| 6 | 896.39 | 38.0 QP | 46.0 | -8.0 | 1.00 V | 327 | 38.7 | -0.7 |

Remarks:

1. Emission Level(dBuV/m) = Raw Value(dBuV) + Correction Factor(dB/m)
2. Correction Factor(dB/m) = Antenna Factor(dB/m) + Cable Factor(dB) – Pre-Amplifier Factor(dB)
3. Margin value = Emission Level – Limit value
4. The other emission levels were very low against the limit of frequency range 30 MHz ~ 1 GHz.
5. The frequency range 9 kHz ~ 30 MHz: all emissions are more than 20 dB below the limit, therefore do not be recorded in this report.

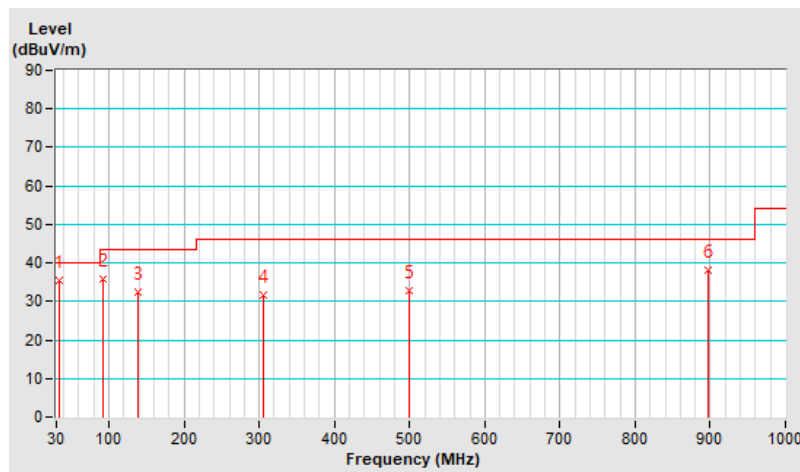

Mode 3

| | | | |
|-----------------|--------------|-------------------|-----------------|
| Frequency Range | 30MHz ~ 1GHz | Detector Function | Quasi-Peak (QP) |
|-----------------|--------------|-------------------|-----------------|

| Antenna Polarity & Test Distance : Horizontal at 3 m | | | | | | | | |
|--|-----------------|-------------------------|----------------|-------------|--------------------|----------------------|------------------|--------------------------|
| No | Frequency (MHz) | Emission Level (dBuV/m) | Limit (dBuV/m) | Margin (dB) | Antenna Height (m) | Table Angle (Degree) | Raw Value (dBuV) | Correction Factor (dB/m) |
| 1 | 94.28 | 34.5 QP | 43.5 | -9.0 | 2.00 H | 132 | 52.9 | -18.4 |
| 2 | 138.93 | 29.5 QP | 43.5 | -14.0 | 1.50 H | 263 | 42.9 | -13.4 |
| 3 | 304.90 | 35.0 QP | 46.0 | -11.0 | 1.50 H | 154 | 47.1 | -12.1 |
| 4 | 406.42 | 32.0 QP | 46.0 | -14.0 | 2.00 H | 123 | 41.7 | -9.7 |
| 5 | 500.00 | 32.8 QP | 46.0 | -13.2 | 2.00 H | 329 | 40.4 | -7.6 |
| 6 | 625.11 | 30.3 QP | 46.0 | -15.7 | 3.00 H | 31 | 35.0 | -4.7 |

Remarks:

1. Emission Level(dBuV/m) = Raw Value(dBuV) + Correction Factor(dB/m)
2. Correction Factor(dB/m) = Antenna Factor(dB/m) + Cable Factor(dB) – Pre-Amplifier Factor(dB)
3. Margin value = Emission Level – Limit value
4. The other emission levels were very low against the limit of frequency range 30 MHz ~ 1 GHz.
5. The frequency range 9 kHz ~ 30 MHz: all emissions are more than 20 dB below the limit, therefore do not be recorded in this report.

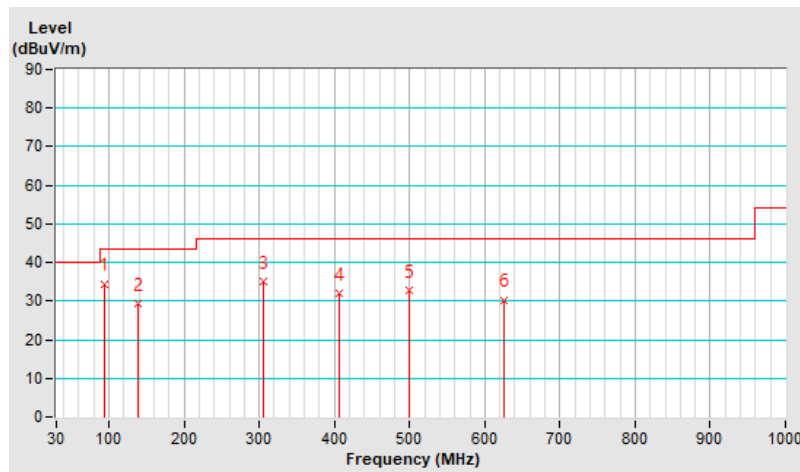

| | | | |
|-----------------|--------------|-------------------|-----------------|
| Frequency Range | 30MHz ~ 1GHz | Detector Function | Quasi-Peak (QP) |
|-----------------|--------------|-------------------|-----------------|

| Antenna Polarity & Test Distance : Vertical at 3 m | | | | | | | | |
|--|-----------------|-------------------------|----------------|-------------|--------------------|----------------------|------------------|--------------------------|
| No | Frequency (MHz) | Emission Level (dBuV/m) | Limit (dBuV/m) | Margin (dB) | Antenna Height (m) | Table Angle (Degree) | Raw Value (dBuV) | Correction Factor (dB/m) |
| 1 | 34.14 | 35.1 QP | 40.0 | -4.9 | 1.50 V | 208 | 48.7 | -13.6 |
| 2 | 91.90 | 36.5 QP | 43.5 | -7.0 | 2.00 V | 341 | 55.0 | -18.5 |
| 3 | 139.81 | 32.7 QP | 43.5 | -10.8 | 1.50 V | 215 | 46.0 | -13.3 |
| 4 | 304.46 | 31.4 QP | 46.0 | -14.6 | 1.00 V | 79 | 43.5 | -12.1 |
| 5 | 499.73 | 31.9 QP | 46.0 | -14.1 | 1.50 V | 176 | 39.5 | -7.6 |
| 6 | 896.49 | 38.4 QP | 46.0 | -7.6 | 1.00 V | 325 | 39.1 | -0.7 |

Remarks:

1. Emission Level(dBuV/m) = Raw Value(dBuV) + Correction Factor(dB/m)
2. Correction Factor(dB/m) = Antenna Factor(dB/m) + Cable Factor(dB) – Pre-Amplifier Factor(dB)
3. Margin value = Emission Level – Limit value
4. The other emission levels were very low against the limit of frequency range 30 MHz ~ 1 GHz.
5. The frequency range 9 kHz ~ 30 MHz: all emissions are more than 20 dB below the limit, therefore do not be recorded in this report.

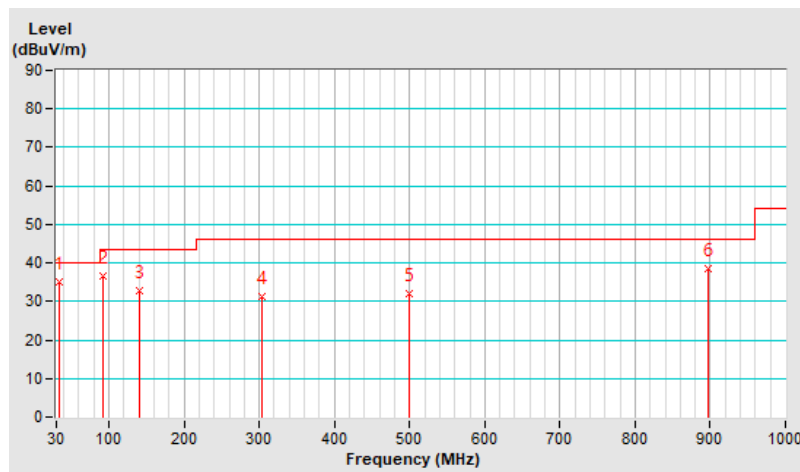

4.2 Conducted Out of Band Emission Measurement

4.2.1 Limits of Conducted Out of Band Emission Measurement

Below 20dB of the highest emission level of operating band (in 100kHz Resolution Bandwidth).

4.2.2 Test Setup

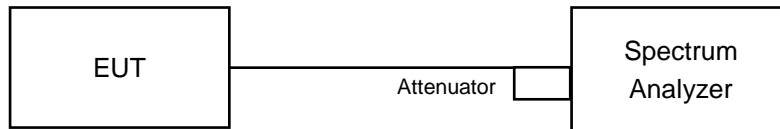

4.2.3 Test Instruments

Refer to section 4.1.2 to get information of above instrument.

4.2.4 Test Procedures

MEASUREMENT PROCEDURE REF

1. Set the RBW = 100 kHz.
2. Set the VBW \geq 300 kHz.
3. Detector = peak.
4. Sweep time = auto couple.
5. Trace mode = max hold.
6. Allow trace to fully stabilize.
7. Use the peak marker function to determine the maximum power level in any 100 kHz band segment within the fundamental EBW.

MEASUREMENT PROCEDURE OOBE

1. Set RBW = 100 kHz.
2. Set VBW \geq 300 kHz.
3. Detector = peak.
4. Sweep = auto couple.
5. Trace Mode = max hold.
6. Allow trace to fully stabilize.
7. Use the peak marker function to determine the maximum amplitude level.

4.2.5 Deviation from Test Standard

No deviation.

4.2.6 EUT Operating Conditions

The software provided by client to enable the EUT under transmission condition continuously at specific channel frequencies individually.

4.2.7 Test Results

The spectrum plots are attached on the following pages. D1 line indicates the highest level, and D2 line indicates the 20dB offset below D1. It shows compliance with the requirement.

2.4GHz_802.11g CH 6 + 5GHz_802.11ac (VHT20) CH 157

Chain 0

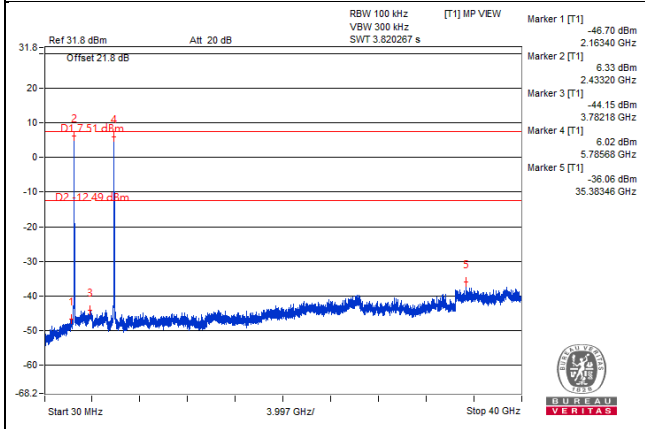

Chain 1

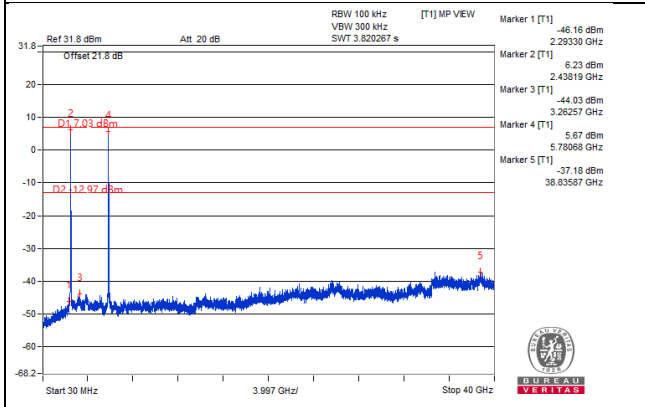

5 Pictures of Test Arrangements

Please refer to the attached file (Test Setup Photo).

Appendix – Information of the Testing Laboratories

We, Bureau Veritas Consumer Products Services (H.K.) Ltd., Taoyuan Branch, were founded in 1988 to provide our best service in EMC, Radio, Telecom and Safety consultation. Our laboratories are FCC recognized accredited test firms and accredited according to ISO/IEC 17025.

If you have any comments, please feel free to contact us at the following:

Lin Kou EMC/RF Lab

Tel: 886-2-26052180

Fax: 886-2-26051924

Hsin Chu EMC/RF/Telecom Lab

Tel: 886-3-6668565

Fax: 886-3-6668323

Hwa Ya EMC/RF/Safety Lab

Tel: 886-3-3183232

Fax: 886-3-3270892

Email: service.adt@tw.bureauveritas.com

Web Site: www.bureauveritas-adt.com

The address and road map of all our labs can be found in our web site also.

--- END ---