

## FCC Test Report (BT-LE)

**Report No.:** RFBDKG-WTW-P21060167-3

**FCC ID:** JNZVR0028

**Test Model:** VR0028

**Received Date:** June 21, 2021

**Test Date:** June 25 to July 03, 2021

**Issued Date:** Aug. 10, 2021

**Applicant:** Logitech Far East Ltd

**Address:** 7700 Gateway Boulevard Newark California United States

**Issued By:** Bureau Veritas Consumer Products Services (H.K.) Ltd., Taoyuan Branch  
Hsin Chu Laboratory

**Lab Address:** E-2, No.1, Li Hsin 1st Road, Hsinchu Science Park, Hsinchu City 300,  
Taiwan

**Test Location:** E-2, No.1, Li Hsin 1st Road, Hsinchu Science Park, Hsinchu City 300,  
Taiwan

**FCC Registration /  
Designation Number:** 723255 / TW2022



This report is for your exclusive use. Any copying or replication of this report to or for any other person or entity, or use of our name or trademark, is permitted only with our prior written permission. This report sets forth our findings solely with respect to the test samples identified herein. The results set forth in this report are not indicative or representative of the quality or characteristics of the lot from which a test sample was taken or any similar or identical product specifically and expressly noted. Our report includes all of the tests requested by you and the results thereof based upon the information that you provided to us. You have 60 days from date of issuance of this report to notify us of any material error or omission caused by our negligence, provided, however, that such notice shall be in writing and shall specifically address the issue you wish to raise. A failure to raise such issue within the prescribed time shall constitute your unqualified acceptance of the completeness of this report, the tests conducted and the correctness of the report contents. Unless specific mention, the uncertainty of measurement has been explicitly taken into account to declare the compliance or non-compliance to the specification.

## Table of Contents

<b>Release Control Record</b> .....	<b>4</b>
<b>1 Certificate of Conformity</b> .....	<b>5</b>
<b>2 Summary of Test Results</b> .....	<b>6</b>
2.1 Measurement Uncertainty.....	6
2.2 Modification Record.....	6
<b>3 General Information</b> .....	<b>7</b>
3.1 General Description of EUT (BT-LE).....	7
3.2 Description of Test Modes.....	8
3.2.1 Test Mode Applicability and Tested Channel Detail.....	9
3.3 Duty Cycle of Test Signal.....	11
3.4 Description of Support Units.....	12
3.4.1 Configuration of System under Test.....	13
3.5 General Description of Applied Standards and References.....	15
<b>4 Test Types and Results</b> .....	<b>16</b>
4.1 Radiated Emission and Bandedge Measurement.....	16
4.1.1 Limits of Radiated Emission and Bandedge Measurement.....	16
4.1.2 Test Instruments.....	17
4.1.3 Test Procedures.....	19
4.1.4 Deviation from Test Standard.....	19
4.1.5 Test Setup.....	20
4.1.6 EUT Operating Conditions.....	21
4.1.7 Test Results.....	22
4.2 Conducted Emission Measurement.....	30
4.2.1 Limits of Conducted Emission Measurement.....	30
4.2.2 Test Instruments.....	30
4.2.3 Test Procedures.....	31
4.2.4 Deviation from Test Standard.....	31
4.2.5 Test Setup.....	31
4.2.6 EUT Operating Conditions.....	31
4.2.7 Test Results.....	32
4.3 6dB Bandwidth Measurement.....	34
4.3.1 Limits of 6dB Bandwidth Measurement.....	34
4.3.2 Test Setup.....	34
4.3.3 Test Instruments.....	34
4.3.4 Test Procedure.....	34
4.3.5 Deviation from Test Standard.....	34
4.3.6 EUT Operating Conditions.....	34
4.3.7 Test Results.....	35
4.4 Conducted Output Power Measurement.....	36
4.4.1 Limits of Conducted Output Power Measurement.....	36
4.4.2 Test Setup.....	36
4.4.3 Test Instruments.....	36
4.4.4 Test Procedures.....	36
4.4.5 Deviation from Test Standard.....	36
4.4.6 EUT Operating Conditions.....	36
4.4.7 Test Results.....	37
4.5 Power Spectral Density Measurement.....	38
4.5.1 Limits of Power Spectral Density Measurement.....	38
4.5.2 Test Setup.....	38
4.5.3 Test Instruments.....	38
4.5.4 Test Procedure.....	38
4.5.5 Deviation from Test Standard.....	38
4.5.6 EUT Operating Condition.....	38

4.5.7 Test Results .....	39
4.6 Conducted Out of Band Emission Measurement.....	40
4.6.1 Limits of Conducted Out of Band Emission Measurement .....	40
4.6.2 Test Setup.....	40
4.6.3 Test Instruments .....	40
4.6.4 Test Procedure .....	40
4.6.5 Deviation from Test Standard .....	40
4.6.6 EUT Operating Condition .....	40
4.6.7 Test Results .....	40
<b>5 Pictures of Test Arrangements.....</b>	<b>43</b>
<b>Annex A - Band-Edge Measurement.....</b>	<b>44</b>
<b>Appendix – Information of the Testing Laboratories .....</b>	<b>46</b>

### Release Control Record

Issue No.	Description	Date Issued
RFBDKG-WTW-P21060167-3	Original release.	Aug. 10, 2021

## 1 Certificate of Conformity

**Product:** TAP Scheduler

**Brand:** Logitech

**Test Model:** VR0028

**Sample Status:** Engineering sample

**Applicant:** Logitech Far East Ltd

**Test Date:** June 25 to July 03, 2021

**Standards:** 47 CFR FCC Part 15, Subpart C (Section 15.247)  
ANSI C63.10: 2013

The above equipment has been tested by **Bureau Veritas Consumer Products Services (H.K.) Ltd., Taoyuan Branch**, and found compliance with the requirement of the above standards. The test record, data evaluation & Equipment Under Test (EUT) configurations represented herein are true and accurate accounts of the measurements of the sample's EMC characteristics under the conditions specified in this report.

**Prepared by :** Phoenix Huang , **Date:** Aug. 10, 2021  
Phoenix Huang / Specialist

**Approved by :** Clark Lin , **Date:** Aug. 10, 2021  
Clark Lin / Technical Manager

## 2 Summary of Test Results

47 CFR FCC Part 15, Subpart C (Section 15.247)			
FCC Clause	Test Item	Result	Remarks
15.207	AC Power Conducted Emission	Pass	Meet the requirement of limit. Minimum passing margin is -5.45 dB at 14.83594 MHz.
15.205 / 15.209 / 15.247(d)	Radiated Emissions and Band Edge Measurement	Pass	Meet the requirement of limit. Minimum passing margin is -7.4 dB at 33.69 MHz.
15.247(d)	Antenna Port Emission	Pass	Meet the requirement of limit.
15.247(a)(2)	6dB bandwidth	Pass	Meet the requirement of limit.
15.247(b)	Conducted power	Pass	Meet the requirement of limit.
15.247(e)	Power Spectral Density	Pass	Meet the requirement of limit.
15.203	Antenna Requirement	Pass	No antenna connector is used.

Note:

- For 2.4 GHz band compliance with rule 15.247(d) of the band-edge items, the test plots were recorded in Annex A.
- Determining compliance based on the results of the compliance measurement, not taking into account measurement instrumentation uncertainty.

### 2.1 Measurement Uncertainty

Where relevant, the following measurement uncertainty levels have been estimated for tests performed on the EUT as specified in CISPR 16-4-2:

Measurement	Frequency	Expanded Uncertainty (k=2) ( $\pm$ )
Conducted Emissions at mains ports	150kHz ~ 30MHz	1.9 dB
Conducted emissions	-	2.5 dB
Radiated Emissions up to 1 GHz	9kHz ~ 30MHz	3.1 dB
	30MHz ~ 1GHz	5.4 dB
Radiated Emissions above 1 GHz	1GHz ~ 18GHz	5.0 dB
	18GHz ~ 40GHz	5.3 dB

### 2.2 Modification Record

There were no modifications required for compliance.

### 3 General Information

#### 3.1 General Description of EUT (BT-LE)

Product	TAP Scheduler
Brand	Logitech
Test Model	VR0028
Status of EUT	Engineering sample
Power Supply Rating	56 Vdc from POE
Modulation Type	GFSK
Transfer Rate	Up to 2 Mbps
Operating Frequency	2.402 ~ 2.480 GHz
Number of Channel	40
Output Power	BT-LE 1M: 1.73 mW BT-LE 2M: 1.722 mW
Antenna Type	Refer to Note
Antenna Connector	Refer to Note
Accessory Device	NA
Cable Supplied	NA

Note:

1. There are WLAN and Bluetooth technology used for the EUT.
2. Simultaneously transmission condition.

Condition	Technology	
1	WLAN (2.4GHz)	WLAN (5GHz)
2	WLAN (2.4GHz)	Bluetooth
3	WLAN (5GHz)	Bluetooth

Note: The emission of the simultaneous operation has been evaluated and no non-compliance was found.

3. The antenna provided to the EUT, please refer to the following table:

Brand	Model	Antenna Net Gain (dBi)	Frequency Range (GHz)	Antenna Type	Connector Type
FIH	S0A260020A0	3	2.4~2.4835	Monopole	None
		4.06	5.15~5.25		
		3.99	5.25~5.35		
		2.95	5.47~5.725		
		1.9	5.725~5.85		

4. The above EUT information is declared by manufacturer and for more detailed features description, please refer to the manufacturer's specifications or user's manual.
5. The above Antenna information is declared by manufacturer and for more detailed features description, please refer to the manufacturer's specifications, the laboratory shall not be held responsible.

### 3.2 Description of Test Modes

40 channels are provided to this EUT:

Channel	Frequency (MHz)	Channel	Frequency (MHz)	Channel	Frequency (MHz)	Channel	Frequency (MHz)
0	2402	10	2422	20	2442	30	2462
1	2404	11	2424	21	2444	31	2464
2	2406	12	2426	22	2446	32	2466
3	2408	13	2428	23	2448	33	2468
4	2410	14	2430	24	2450	34	2470
5	2412	15	2432	25	2452	35	2472
6	2414	16	2434	26	2454	36	2474
7	2416	17	2436	27	2456	37	2476
8	2418	18	2438	28	2458	38	2478
9	2420	19	2440	29	2460	39	2480



### 3.2.1 Test Mode Applicability and Tested Channel Detail

EUT Configure Mode	Applicable To				Description
	RE $\geq$ 1G	RE $<$ 1G	PLC	APCM	
-	√	√	√	√	-

Where **RE $\geq$ 1G**: Radiated Emission above 1GHz & Bandedge Measurement  
**RE $<$ 1G**: Radiated Emission below 1GHz  
**PLC**: Power Line Conducted Emission  
**APCM**: Antenna Port Conducted Measurement

#### **Radiated Emission Test (Above 1GHz):**

- Pre-Scan has been conducted to determine the worst-case mode from all possible combinations between available modulations, data rates and antenna ports (if EUT with antenna diversity architecture).
- Following channel(s) was (were) selected for the final test as listed below.

Available Channel	Tested Channel	Modulation Type	Data Rate (Mbps)
0 to 39	0, 19, 39	GFSK	1
0 to 39	0, 19, 39	GFSK	2

#### **Radiated Emission Test (Below 1GHz):**

- Pre-Scan has been conducted to determine the worst-case mode from all possible combinations between available modulations, data rates and antenna ports (if EUT with antenna diversity architecture).
- Following channel(s) was (were) selected for the final test as listed below.

Available Channel	Tested Channel	Modulation Type	Data Rate (Mbps)
0 to 39	19	GFSK	2

#### **Power Line Conducted Emission Test:**

- Pre-Scan has been conducted to determine the worst-case mode from all possible combinations between available modulations, data rates and antenna ports (if EUT with antenna diversity architecture).
- Following channel(s) was (were) selected for the final test as listed below.

Available Channel	Tested Channel	Modulation Type	Data Rate (Mbps)
0 to 39	19	GFSK	2

#### **Antenna Port Conducted Measurement:**

- This item includes all test value of each mode, but only includes spectrum plot of worst value of each mode.
- Pre-Scan has been conducted to determine the worst-case mode from all possible combinations between available modulations, data rates and antenna ports (if EUT with antenna diversity architecture).
- Following channel(s) was (were) selected for the final test as listed below.

Available Channel	Tested Channel	Modulation Type	Data Rate (Mbps)
0 to 39	0, 19, 39	GFSK	1
0 to 39	0, 19, 39	GFSK	2

**Test Condition:**

Applicable To	Environmental Conditions	Input Power (System)	Tested By
RE $\geq$ 1G	25deg. C, 65%RH	120Vac, 60Hz	Nelson Teng
RE<1G	25deg. C, 70%RH	120Vac, 60Hz	Ryan Du
PLC	25deg. C, 75%RH	120Vac, 60Hz	Ryan Du
APCM	25deg. C, 60%RH	120Vac, 60Hz	Kevin Ko

### 3.3 Duty Cycle of Test Signal

Duty cycle of test signal is < 98 %, duty factor shall be considered.

**BT-LE 1M:** Duty cycle = 0.379 ms/0.625 ms = 0.606, Duty factor =  $10 * \log( 1/\text{Duty cycle} ) = 2.17 \text{ dB}$

**BT-LE 2M:** Duty cycle = 1.066 ms/1.876 ms = 0.568, Duty factor =  $10 * \log( 1/\text{Duty cycle} ) = 2.45 \text{ dB}$

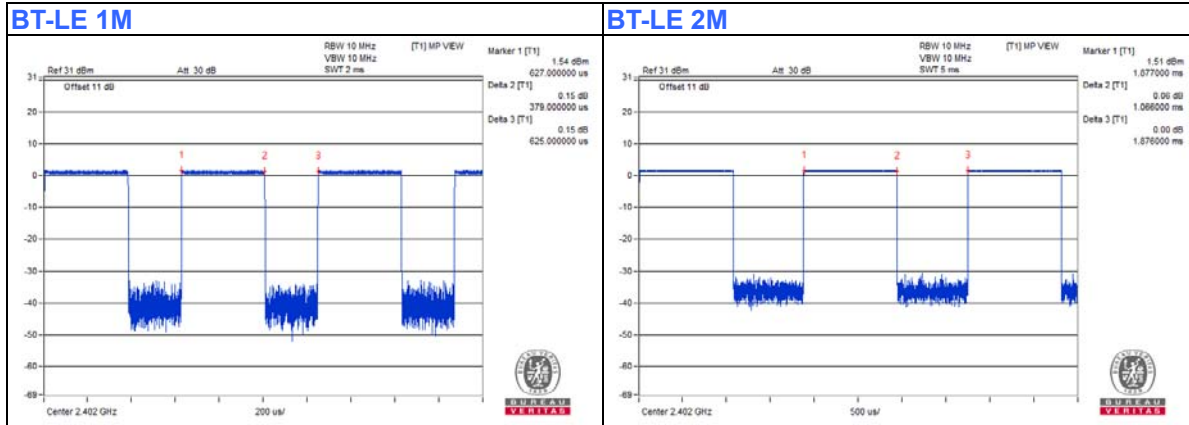

### 3.4 Description of Support Units

The EUT has been tested as an independent unit together with other necessary accessories or support units. The following support units or accessories were used to form a representative test configuration during the tests.

ID	Product	Brand	Model No.	Serial No.	FCC ID	Remarks
A.	PoE	BulletPoE	BPI100-H	NA	NA	Supplied by client
B.	Laptop	Lenovo	20U5S01X00 L14	PF-1ANPYA	NA	Provided by Lab

Note:

1. All power cords of the above support units are non-shielded (1.8m).

ID	Descriptions	Qty.	Length (m)	Shielding (Yes/No)	Cores (Qty.)	Remarks
1.	RJ-45 Cable	1	10	No	0	Provided by Lab
2.	AC Cable	1	1.8	No	0	Provided by Lab
3.	RJ-45 Cable	1	1.5	No	0	Supplied by client

### 3.4.1 Configuration of System under Test

#### For AC Power Conducted Emission test:

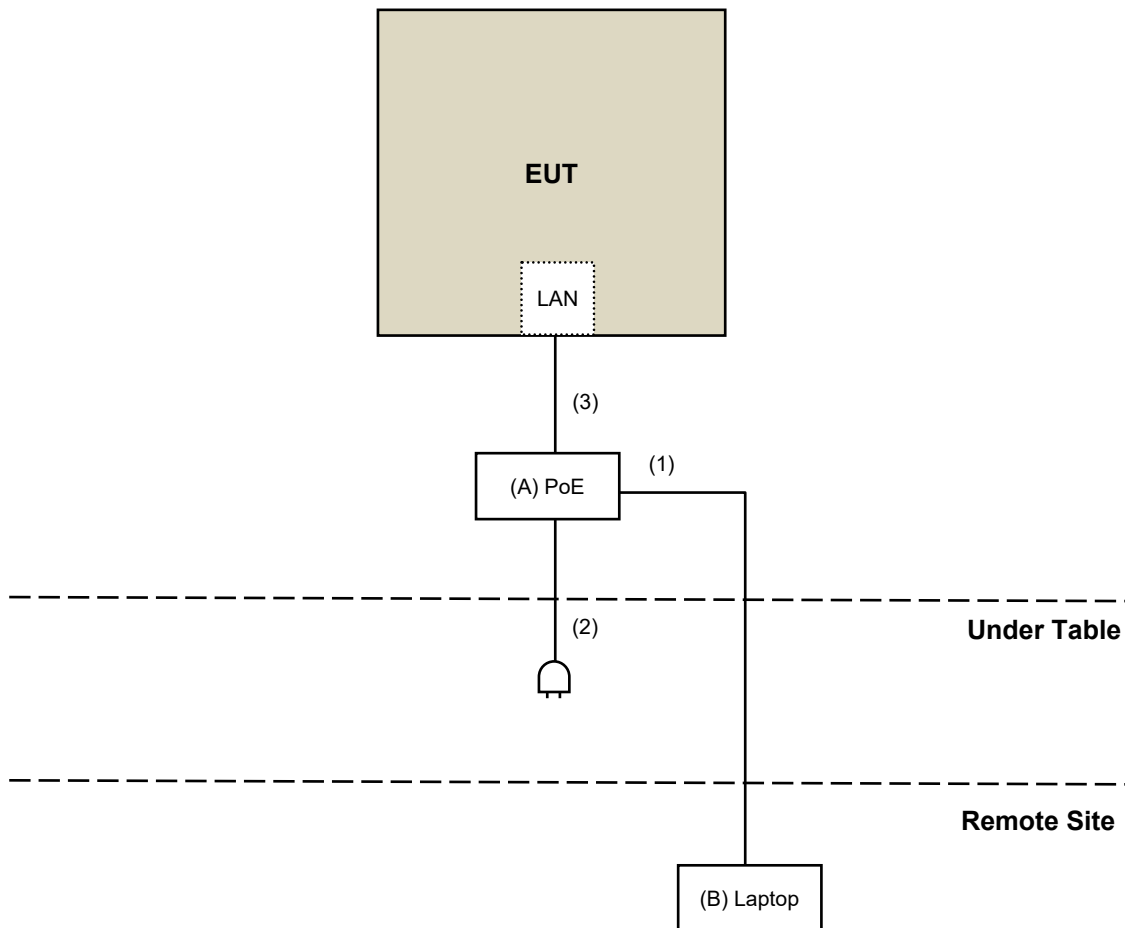

**For Radiated Emission test:**

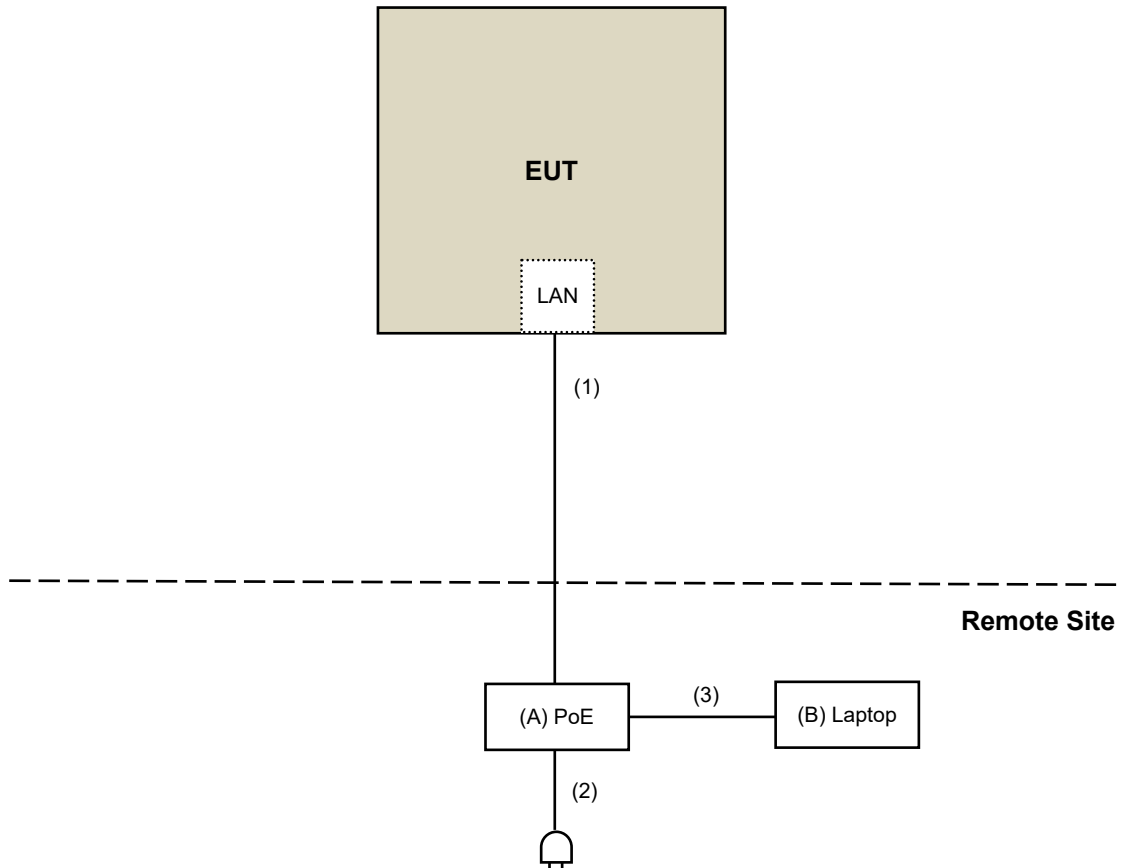

### 3.5 General Description of Applied Standards and References

The EUT is a RF Product. According to the specifications of the manufacturer, it must comply with the requirements of the following standards and references:

**Test Standard:**

**FCC Part 15, Subpart C (15.247)**

**ANSI C63.10-2013**

All test items have been performed and recorded as per the above standards.

**References Test Guidance:**

**KDB 558074 D01 15.247 Meas Guidance v05r02**

All test items have been performed as a reference to the above KDB test guidance.

## 4 Test Types and Results

### 4.1 Radiated Emission and Bandedge Measurement

#### 4.1.1 Limits of Radiated Emission and Bandedge Measurement

Radiated emissions which fall in the restricted bands must comply with the radiated emission limits specified as below table. Other emissions shall be at least 20dB below the highest level of the desired power:

Frequencies (MHz)	Field Strength (microvolts/meter)	Measurement Distance (meters)
0.009 ~ 0.490	2400/F(kHz)	300
0.490 ~ 1.705	24000/F(kHz)	30
1.705 ~ 30.0	30	30
30 ~ 88	100	3
88 ~ 216	150	3
216 ~ 960	200	3
Above 960	500	3

**Note:**

1. The lower limit shall apply at the transition frequencies.
2. Emission level (dBuV/m) = 20 log Emission level (uV/m).
3. For frequencies above 1000MHz, the field strength limits are based on average detector, however, the peak field strength of any emission shall not exceed the maximum permitted average limits, specified above by more than 20dB under any condition of modulation.



## 4.1.2 Test Instruments

**For Radiated emission test:**

DESCRIPTION & MANUFACTURER	MODEL NO.	SERIAL NO.	CALIBRATED DATE	CALIBRATED UNTIL
Test Receiver Keysight	N9038A	MY54450088	July 06, 2020	July 05, 2021
Pre-Amplifier EMCI	EMC001340	980142	May 24, 2021	May 23, 2022
Loop Antenna Electro-Metrics	EM-6879	264	Mar. 05, 2021	Mar. 04, 2022
RF Cable	5D-FB	LOOPCAB-001	Jan. 07, 2021	Jan. 06, 2022
RF Cable	5D-FB	LOOPCAB-002	Jan. 07, 2021	Jan. 06, 2022
Pre-Amplifier Mini-Circuits	ZFL-1000VH2	QA0838008	Oct. 20, 2020	Oct. 19, 2021
Trilog Broadband Antenna SCHWARZBECK	VULB 9168	9168-361	Nov. 05, 2020	Nov. 04, 2021
RF Cable	8D	966-3-1	Mar. 16, 2021	Mar. 15, 2022
RF Cable	8D	966-3-2	Mar. 16, 2021	Mar. 15, 2022
RF Cable	8D	966-3-3	Mar. 16, 2021	Mar. 15, 2022
Fixed attenuator Mini-Circuits	UNAT-5+	PAD-3m-3-01	Sep. 24, 2020	Sep. 23, 2021
Horn_Antenna SCHWARZBECK	BBHA9120-D	9120D-406	Nov. 22, 2020	Nov. 21, 2021
Pre-Amplifier EMCI	EMC12630SE	980384	Jan. 11, 2021	Jan. 10, 2022
RF Cable	EMC104-SM-SM-1500	180504	Apr. 26, 2021	Apr. 25, 2022
RF Cable	EMC104-SM-SM-2000	180601	June 08, 2021	June 07, 2022
RF Cable	EMC104-SM-SM-6000	210201	May 13, 2021	May 12, 2022
Spectrum Analyzer Keysight	N9030A	MY54490679	July 13, 2020	July 12, 2021
Pre-Amplifier EMCI	EMC184045SE	980387	Jan. 11, 2021	Jan. 10, 2022
Horn_Antenna SCHWARZBECK	BBHA 9170	BBHA9170519	Nov. 22, 2020	Nov. 21, 2021
RF Cable	EMC102-KM-KM-1200	160924	Jan. 11, 2021	Jan. 10, 2022
RF Cable	EMC-KM-KM-4000	200214	Mar. 10, 2021	Mar. 09, 2022
Software	ADT_Radiated_V8.7.08	NA	NA	NA
Antenna Tower & Turn Table Max-Full	MF-7802	MF780208406	NA	NA
Boresight Antenna Fixture	FBA-01	FBA-SIP01	NA	NA

**Note:**

1. The calibration interval of the above test instruments is 12 months and the calibrations are traceable to NML/ROC and NIST/USA.
2. The test was performed in 966 Chamber No. 3.
3. Tested Date: June 30 to July 03, 2021

**For other test items:**

DESCRIPTION & MANUFACTURER	MODEL NO.	SERIAL NO.	CALIBRATED DATE	CALIBRATED UNTIL
Spectrum Analyzer R&S	FSV40	101516	Mar. 08, 2021	Mar. 07, 2022
Power meter Anritsu	ML2495A	1529002	June 21, 2021	June 20, 2022
Power sensor Anritsu	MA2411B	1339443	May 31, 2021	May 30, 2022
10dB Attenuator Woken	MDCS18N-10	MDCS18N-10-01	Apr. 13, 2021	Apr. 12, 2022
Software	ADT_RF Test Software V6.6.5.4	NA	NA	NA

- NOTE:**
1. The test was performed in Oven room 2.
  2. The calibration interval of the above test instruments is 12 months and the calibrations are traceable to NML/ROC and NIST/USA.
  3. Tested Date: June 25, 2021

#### 4.1.3 Test Procedures

##### **For Radiated emission below 30MHz**

- a. The EUT was placed on the top of a rotating table 0.8 meters above the ground at a 3 meter chamber room. The table was rotated 360 degrees to determine the position of the highest radiation.
- b. The EUT was set 3 meters away from the interference-receiving antenna, which was mounted on the top of a variable-height antenna tower.
- c. Parallel, perpendicular, and ground-parallel orientations of the antenna are set to make the measurement.
- d. For each suspected emission, the EUT was arranged to its worst case and the rotatable table was turned from 0 degrees to 360 degrees to find the maximum reading.
- e. The test-receiver system was set to Quasi-Peak Detect Function and Specified Bandwidth with Maximum Hold Mode.

##### **Note:**

1. The resolution bandwidth and video bandwidth of test receiver/spectrum analyzer is 9kHz at frequency below 30MHz.

##### **For Radiated emission above 30MHz**

- a. The EUT was placed on the top of a rotating table 0.8 meters (for 30MHz ~ 1GHz) / 1.5 meters (for above 1GHz) above the ground at 3 meter chamber room for test. The table was rotated 360 degrees to determine the position of the highest radiation.
- b. The EUT was set 3 meters away from the interference-receiving antenna, which was mounted on the top of a variable-height antenna tower.
- c. The height of antenna is varied from one meter to four meters above the ground to determine the maximum value of the field strength. Both horizontal and vertical polarizations of the antenna are set to make the measurement.
- d. For each suspected emission, the EUT was arranged to its worst case and then the antenna was tuned to heights from 1 meter to 4 meters and the rotatable table was turned from 0 degrees to 360 degrees to find the maximum reading.
- e. The test-receiver system was set to quasi-peak detect function and specified bandwidth with maximum hold mode when the test frequency is below 1 GHz.
- f. The test-receiver system was set to peak and average detects function and specified bandwidth with maximum hold mode when the test frequency is above 1 GHz. If the peak reading value also meets average limit, measurement with the average detector is unnecessary.

##### **Note:**

1. The resolution bandwidth and video bandwidth of test receiver/spectrum analyzer is 120kHz for Quasi-peak detection (QP) at frequency below 1GHz.
2. The resolution bandwidth of test receiver/spectrum analyzer is 1 MHz and the video bandwidth is 3 MHz for Peak detection (PK) at frequency above 1GHz.
3. The resolution bandwidth of test receiver/spectrum analyzer is 1MHz and the video bandwidth is  $\geq 1/T$  (Duty cycle < 98%) or 10Hz (Duty cycle  $\geq 98\%$ ) for Average detection (AV) at frequency above 1GHz.
4. All modes of operation were investigated and the worst-case emissions are reported.

#### 4.1.4 Deviation from Test Standard

No deviation.

#### 4.1.5 Test Setup

##### For Radiated emission below 30MHz

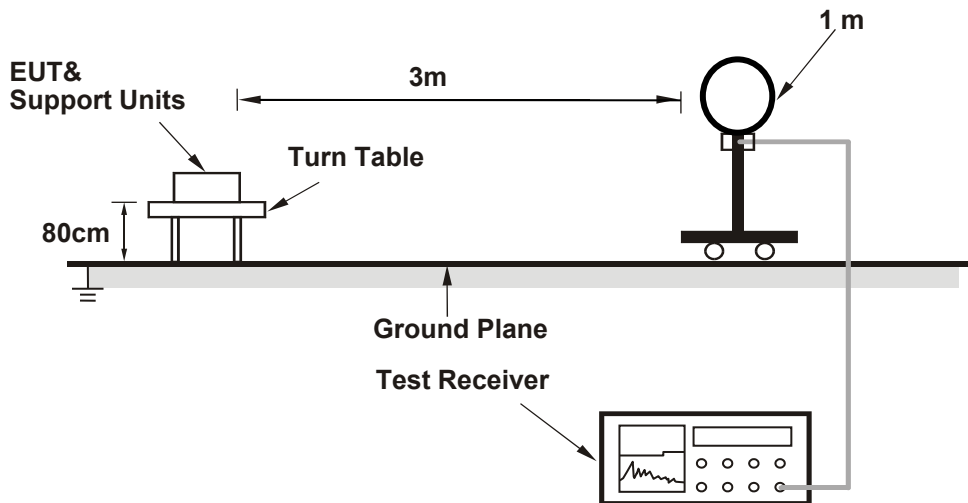

##### For Radiated emission 30MHz to 1GHz

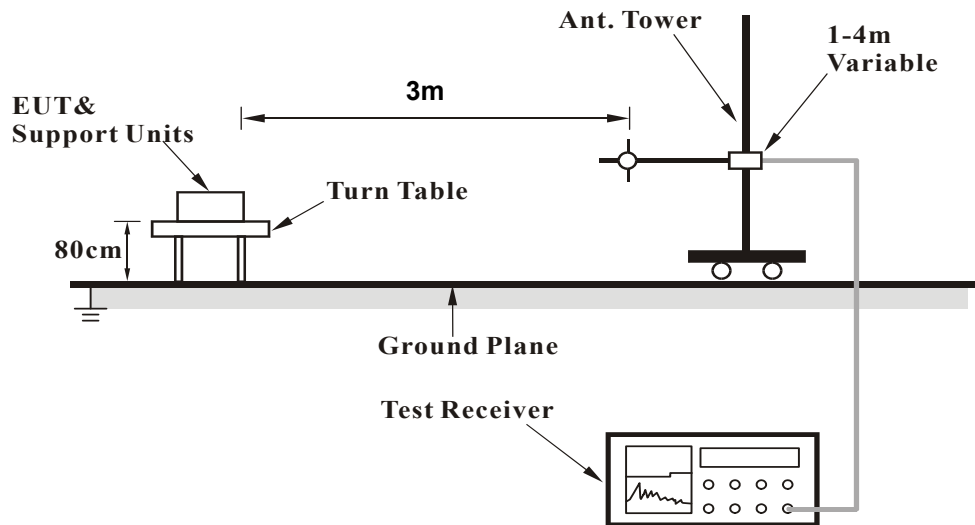

### For Radiated emission above 1GHz

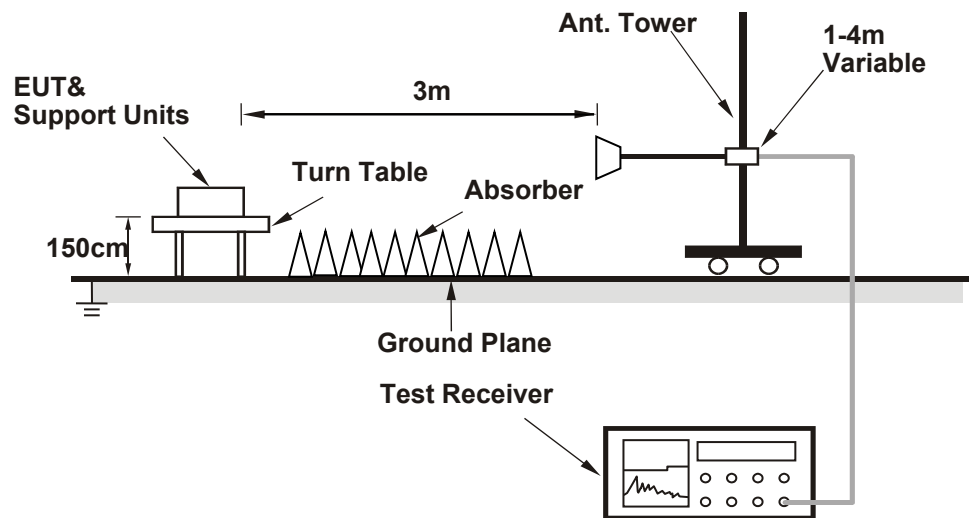

For the actual test configuration, please refer to the attached file (Test Setup Photo).

#### 4.1.6 EUT Operating Conditions

- Placed the EUT on the testing table.
- Controlling software (SP META) has been activated to set the EUT under transmission condition continuously at specific channel frequency.

#### 4.1.7 Test Results

##### Above 1GHz Data:

<b>RF Mode</b>	TX BT-LE 1M	<b>Channel</b>	CH 0 : 2402 MHz
<b>Frequency Range</b>	1GHz ~ 25GHz	<b>Detector Function</b>	Peak (PK) Average (AV)

Antenna Polarity & Test Distance : Horizontal at 3 m								
No	Frequency (MHz)	Emission Level (dBuV/m)	Limit (dBuV/m)	Margin (dB)	Antenna Height (m)	Table Angle (Degree)	Raw Value (dBuV)	Correction Factor (dB/m)
1	2378.55	55.3 PK	74.0	-18.7	1.15 H	155	56.5	-1.2
2	2378.55	42.9 AV	54.0	-11.1	1.15 H	155	44.1	-1.2
3	*2402.00	97.5 PK			1.15 H	155	98.7	-1.2
4	*2402.00	96.4 AV			1.15 H	155	97.6	-1.2
5	4804.00	44.1 PK	74.0	-29.9	1.72 H	183	40.3	3.8
6	4804.00	33.9 AV	54.0	-20.1	1.72 H	183	30.1	3.8
Antenna Polarity & Test Distance : Vertical at 3 m								
No	Frequency (MHz)	Emission Level (dBuV/m)	Limit (dBuV/m)	Margin (dB)	Antenna Height (m)	Table Angle (Degree)	Raw Value (dBuV)	Correction Factor (dB/m)
1	2363.90	54.9 PK	74.0	-19.1	1.11 V	91	56.0	-1.1
2	2363.90	43.8 AV	54.0	-10.2	1.11 V	91	44.9	-1.1
3	*2402.00	97.2 PK			1.11 V	91	98.4	-1.2
4	*2402.00	96.0 AV			1.11 V	91	97.2	-1.2
5	4804.00	44.0 PK	74.0	-30.0	1.72 V	166	40.2	3.8
6	4804.00	33.7 AV	54.0	-20.3	1.72 V	166	29.9	3.8

##### Remarks:

1. Emission Level(dBuV/m) = Raw Value(dBuV) + Correction Factor(dB/m)
2. Correction Factor(dB/m) = Antenna Factor(dB/m) + Cable Factor(dB) – Pre-Amplifier Factor(dB)
3. Margin value = Emission Level – Limit value
4. The other emission levels were very low against the limit.
5. " \* ": Fundamental frequency.

<b>RF Mode</b>	TX BT-LE 1M	<b>Channel</b>	CH 19 : 2440 MHz
<b>Frequency Range</b>	1GHz ~ 25GHz	<b>Detector Function</b>	Peak (PK) Average (AV)

**Antenna Polarity & Test Distance : Horizontal at 3 m**

No	Frequency (MHz)	Emission Level (dBuV/m)	Limit (dBuV/m)	Margin (dB)	Antenna Height (m)	Table Angle (Degree)	Raw Value (dBuV)	Correction Factor (dB/m)
1	*2440.00	99.7 PK			1.12 H	165	100.9	-1.2
2	*2440.00	98.4 AV			1.12 H	165	99.6	-1.2
3	4880.00	44.0 PK	74.0	-30.0	1.69 H	144	40.2	3.8
4	4880.00	34.0 AV	54.0	-20.0	1.69 H	144	30.2	3.8
5	7320.00	44.2 PK	74.0	-29.8	1.66 H	136	34.5	9.7
6	7320.00	34.4 AV	54.0	-19.6	1.66 H	136	24.7	9.7

**Antenna Polarity & Test Distance : Vertical at 3 m**

No	Frequency (MHz)	Emission Level (dBuV/m)	Limit (dBuV/m)	Margin (dB)	Antenna Height (m)	Table Angle (Degree)	Raw Value (dBuV)	Correction Factor (dB/m)
1	*2440.00	97.4 PK			1.04 V	99	98.6	-1.2
2	*2440.00	96.1 AV			1.04 V	99	97.3	-1.2
3	4880.00	44.5 PK	74.0	-29.5	1.73 V	148	40.7	3.8
4	4880.00	34.1 AV	54.0	-19.9	1.73 V	148	30.3	3.8
5	7320.00	44.0 PK	74.0	-30.0	1.62 V	131	34.3	9.7
6	7320.00	34.0 AV	54.0	-20.0	1.62 V	131	24.3	9.7

**Remarks:**

1. Emission Level(dBuV/m) = Raw Value(dBuV) + Correction Factor(dB/m)
2. Correction Factor(dB/m) = Antenna Factor(dB/m) + Cable Factor(dB) – Pre-Amplifier Factor(dB)
3. Margin value = Emission Level – Limit value
4. The other emission levels were very low against the limit.
5. " \* ": Fundamental frequency.

<b>RF Mode</b>	TX BT-LE 1M	<b>Channel</b>	CH 39 : 2480 MHz
<b>Frequency Range</b>	1GHz ~ 25GHz	<b>Detector Function</b>	Peak (PK) Average (AV)

Antenna Polarity & Test Distance : Horizontal at 3 m								
No	Frequency (MHz)	Emission Level (dBuV/m)	Limit (dBuV/m)	Margin (dB)	Antenna Height (m)	Table Angle (Degree)	Raw Value (dBuV)	Correction Factor (dB/m)
1	*2480.00	99.8 PK			1.15 H	163	101.0	-1.2
2	*2480.00	98.6 AV			1.15 H	163	99.8	-1.2
3	2486.90	53.8 PK	74.0	-20.2	1.15 H	163	55.0	-1.2
4	2486.90	43.2 AV	54.0	-10.8	1.15 H	163	44.4	-1.2
5	4960.00	44.2 PK	74.0	-29.8	1.73 H	147	40.2	4.0
6	4960.00	33.7 AV	54.0	-20.3	1.73 H	147	29.7	4.0
7	7440.00	43.7 PK	74.0	-30.3	1.59 H	123	34.0	9.7
8	7440.00	33.8 AV	54.0	-20.2	1.59 H	123	24.1	9.7

Antenna Polarity & Test Distance : Vertical at 3 m								
No	Frequency (MHz)	Emission Level (dBuV/m)	Limit (dBuV/m)	Margin (dB)	Antenna Height (m)	Table Angle (Degree)	Raw Value (dBuV)	Correction Factor (dB/m)
1	*2480.00	96.9 PK			1.10 V	87	98.1	-1.2
2	*2480.00	95.7 AV			1.10 V	87	96.9	-1.2
3	2485.10	54.4 PK	74.0	-19.6	1.10 V	87	55.6	-1.2
4	2485.10	43.3 AV	54.0	-10.7	1.10 V	87	44.5	-1.2
5	4960.00	43.9 PK	74.0	-30.1	1.76 V	152	39.9	4.0
6	4960.00	34.0 AV	54.0	-20.0	1.76 V	152	30.0	4.0
7	7440.00	44.2 PK	74.0	-29.8	1.67 V	153	34.5	9.7
8	7440.00	34.2 AV	54.0	-19.8	1.67 V	153	24.5	9.7

**Remarks:**

1. Emission Level(dBuV/m) = Raw Value(dBuV) + Correction Factor(dB/m)
2. Correction Factor(dB/m) = Antenna Factor(dB/m) + Cable Factor(dB) – Pre-Amplifier Factor(dB)
3. Margin value = Emission Level – Limit value
4. The other emission levels were very low against the limit.
5. " \* ": Fundamental frequency.



<b>RF Mode</b>	TX BT-LE 2M	<b>Channel</b>	CH 0 : 2402 MHz
<b>Frequency Range</b>	1GHz ~ 25GHz	<b>Detector Function</b>	Peak (PK) Average (AV)

**Antenna Polarity & Test Distance : Horizontal at 3 m**

No	Frequency (MHz)	Emission Level (dBuV/m)	Limit (dBuV/m)	Margin (dB)	Antenna Height (m)	Table Angle (Degree)	Raw Value (dBuV)	Correction Factor (dB/m)
1	2333.90	55.1 PK	74.0	-18.9	1.23 H	154	56.1	-1.0
2	2333.90	42.8 AV	54.0	-11.2	1.23 H	154	43.8	-1.0
3	*2402.00	98.5 PK			1.23 H	154	99.7	-1.2
4	*2402.00	95.1 AV			1.23 H	154	96.3	-1.2
5	4804.00	43.7 PK	74.0	-30.3	1.69 H	179	39.9	3.8
6	4804.00	33.5 AV	54.0	-20.5	1.69 H	179	29.7	3.8

**Antenna Polarity & Test Distance : Vertical at 3 m**

No	Frequency (MHz)	Emission Level (dBuV/m)	Limit (dBuV/m)	Margin (dB)	Antenna Height (m)	Table Angle (Degree)	Raw Value (dBuV)	Correction Factor (dB/m)
1	2342.80	55.2 PK	74.0	-18.8	1.12 V	93	56.3	-1.1
2	2342.80	43.1 AV	54.0	-10.9	1.12 V	93	44.2	-1.1
3	*2402.00	97.1 PK			1.12 V	93	98.3	-1.2
4	*2402.00	94.0 AV			1.12 V	93	95.2	-1.2
5	4804.00	44.1 PK	74.0	-29.9	1.75 V	168	40.3	3.8
6	4804.00	34.2 AV	54.0	-19.8	1.75 V	168	30.4	3.8

**Remarks:**

1. Emission Level(dBuV/m) = Raw Value(dBuV) + Correction Factor(dB/m)
2. Correction Factor(dB/m) = Antenna Factor(dB/m) + Cable Factor(dB) – Pre-Amplifier Factor(dB)
3. Margin value = Emission Level – Limit value
4. The other emission levels were very low against the limit.
5. " \* " : Fundamental frequency.

<b>RF Mode</b>	TX BT-LE 2M	<b>Channel</b>	CH 19 : 2440 MHz
<b>Frequency Range</b>	1GHz ~ 25GHz	<b>Detector Function</b>	Peak (PK) Average (AV)

**Antenna Polarity & Test Distance : Horizontal at 3 m**

No	Frequency (MHz)	Emission Level (dBuV/m)	Limit (dBuV/m)	Margin (dB)	Antenna Height (m)	Table Angle (Degree)	Raw Value (dBuV)	Correction Factor (dB/m)
1	*2440.00	99.3 PK			1.13 H	148	100.5	-1.2
2	*2440.00	96.3 AV			1.13 H	148	97.5	-1.2
3	4880.00	44.4 PK	74.0	-29.6	1.65 H	144	40.6	3.8
4	4880.00	34.4 AV	54.0	-19.6	1.65 H	144	30.6	3.8
5	7320.00	44.1 PK	74.0	-29.9	1.60 H	136	34.4	9.7
6	7320.00	34.2 AV	54.0	-19.8	1.60 H	136	24.5	9.7

**Antenna Polarity & Test Distance : Vertical at 3 m**

No	Frequency (MHz)	Emission Level (dBuV/m)	Limit (dBuV/m)	Margin (dB)	Antenna Height (m)	Table Angle (Degree)	Raw Value (dBuV)	Correction Factor (dB/m)
1	*2440.00	97.3 PK			1.23 V	80	98.5	-1.2
2	*2440.00	94.3 AV			1.23 V	80	95.5	-1.2
3	4880.00	44.1 PK	74.0	-29.9	1.70 V	171	40.3	3.8
4	4880.00	34.0 AV	54.0	-20.0	1.70 V	171	30.2	3.8
5	7320.00	43.8 PK	74.0	-30.2	1.59 V	145	34.1	9.7
6	7320.00	33.8 AV	54.0	-20.2	1.59 V	145	24.1	9.7

**Remarks:**

1. Emission Level(dBuV/m) = Raw Value(dBuV) + Correction Factor(dB/m)
2. Correction Factor(dB/m) = Antenna Factor(dB/m) + Cable Factor(dB) – Pre-Amplifier Factor(dB)
3. Margin value = Emission Level – Limit value
4. The other emission levels were very low against the limit.
5. " \* ": Fundamental frequency.

<b>RF Mode</b>	TX BT-LE 2M	<b>Channel</b>	CH 39 : 2480 MHz
<b>Frequency Range</b>	1GHz ~ 25GHz	<b>Detector Function</b>	Peak (PK) Average (AV)

Antenna Polarity & Test Distance : Horizontal at 3 m								
No	Frequency (MHz)	Emission Level (dBuV/m)	Limit (dBuV/m)	Margin (dB)	Antenna Height (m)	Table Angle (Degree)	Raw Value (dBuV)	Correction Factor (dB/m)
1	*2480.00	99.8 PK			1.14 H	157	101.0	-1.2
2	*2480.00	96.5 AV			1.14 H	157	97.7	-1.2
3	2483.90	54.2 PK	74.0	-19.8	1.14 H	157	55.4	-1.2
4	2483.90	43.1 AV	54.0	-10.9	1.14 H	157	44.3	-1.2
5	4960.00	44.1 PK	74.0	-29.9	1.77 H	170	40.1	4.0
6	4960.00	33.8 AV	54.0	-20.2	1.77 H	170	29.8	4.0
7	7440.00	44.9 PK	74.0	-29.1	1.59 H	130	35.2	9.7
8	7440.00	34.6 AV	54.0	-19.4	1.59 H	130	24.9	9.7

Antenna Polarity & Test Distance : Vertical at 3 m								
No	Frequency (MHz)	Emission Level (dBuV/m)	Limit (dBuV/m)	Margin (dB)	Antenna Height (m)	Table Angle (Degree)	Raw Value (dBuV)	Correction Factor (dB/m)
1	*2480.00	97.2 PK			1.19 V	83	98.4	-1.2
2	*2480.00	94.2 AV			1.19 V	83	95.4	-1.2
3	2494.10	53.9 PK	74.0	-20.1	1.19 V	83	55.1	-1.2
4	2494.10	42.6 AV	54.0	-11.4	1.19 V	83	43.8	-1.2
5	4960.00	44.1 PK	74.0	-29.9	1.75 V	160	40.1	4.0
6	4960.00	33.7 AV	54.0	-20.3	1.75 V	160	29.7	4.0
7	7440.00	44.5 PK	74.0	-29.5	1.66 V	145	34.8	9.7
8	7440.00	34.6 AV	54.0	-19.4	1.66 V	145	24.9	9.7

**Remarks:**

1. Emission Level(dBuV/m) = Raw Value(dBuV) + Correction Factor(dB/m)
2. Correction Factor(dB/m) = Antenna Factor(dB/m) + Cable Factor(dB) – Pre-Amplifier Factor(dB)
3. Margin value = Emission Level – Limit value
4. The other emission levels were very low against the limit.
5. " \* ": Fundamental frequency.

### Below 1GHz Data:

<b>RF Mode</b>	TX BT-LE 2M	<b>Channel</b>	CH 19 : 2440 MHz
<b>Frequency Range</b>	9kHz ~ 1GHz	<b>Detector Function</b>	Quasi-Peak (QP)

Antenna Polarity & Test Distance : Horizontal at 3 m								
No	Frequency (MHz)	Emission Level (dBuV/m)	Limit (dBuV/m)	Margin (dB)	Antenna Height (m)	Table Angle (Degree)	Raw Value (dBuV)	Correction Factor (dB/m)
1	35.25	28.2 QP	40.0	-11.8	2.00 H	139	37.4	-9.2
2	55.38	28.5 QP	40.0	-11.5	2.00 H	247	36.8	-8.3
3	88.09	25.5 QP	43.5	-18.0	2.00 H	249	39.4	-13.9
4	179.39	32.3 QP	43.5	-11.2	1.50 H	62	41.4	-9.1
5	254.30	25.8 QP	46.0	-20.2	1.00 H	147	34.3	-8.5
6	443.30	26.1 QP	46.0	-19.9	1.50 H	35	28.3	-2.2

### Remarks:

1. Emission Level(dBuV/m) = Raw Value(dBuV) + Correction Factor(dB/m)
2. Correction Factor(dB/m) = Antenna Factor(dB/m) + Cable Factor(dB) – Pre-Amplifier Factor(dB)
3. Margin value = Emission Level – Limit value
4. The other emission levels were very low against the limit of frequency range 30MHz~1000MHz.
5. The emission levels were very low against the limit of frequency range 9kHz~30MHz: the amplitude of spurious emissions attenuated more than 20 dB below the permissible value to be report.

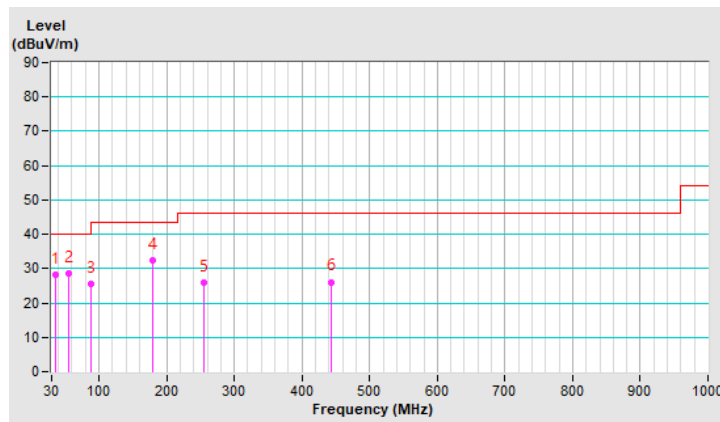

<b>RF Mode</b>	TX BT-LE 2M	<b>Channel</b>	CH 19 : 2440 MHz
<b>Frequency Range</b>	9kHz ~ 1GHz	<b>Detector Function</b>	Quasi-Peak (QP)

**Antenna Polarity & Test Distance : Vertical at 3 m**

No	Frequency (MHz)	Emission Level (dBuV/m)	Limit (dBuV/m)	Margin (dB)	Antenna Height (m)	Table Angle (Degree)	Raw Value (dBuV)	Correction Factor (dB/m)
1	33.69	32.6 QP	40.0	-7.4	1.50 V	317	41.8	-9.2
2	61.00	26.1 QP	40.0	-13.9	1.00 V	154	35.1	-9.0
3	115.57	22.9 QP	43.5	-20.6	1.50 V	313	33.1	-10.2
4	177.24	25.7 QP	43.5	-17.8	1.00 V	305	34.6	-8.9
5	186.66	30.6 QP	43.5	-12.9	1.00 V	134	40.5	-9.9
6	435.82	26.1 QP	46.0	-19.9	2.00 V	306	28.4	-2.3

**Remarks:**

1. Emission Level(dBuV/m) = Raw Value(dBuV) + Correction Factor(dB/m)
2. Correction Factor(dB/m) = Antenna Factor(dB/m) + Cable Factor(dB) – Pre-Amplifier Factor(dB)
3. Margin value = Emission Level – Limit value
4. The other emission levels were very low against the limit of frequency range 30MHz~1000MHz.
5. The emission levels were very low against the limit of frequency range 9kHz~30MHz: the amplitude of spurious emissions attenuated more than 20 dB below the permissible value to be report.

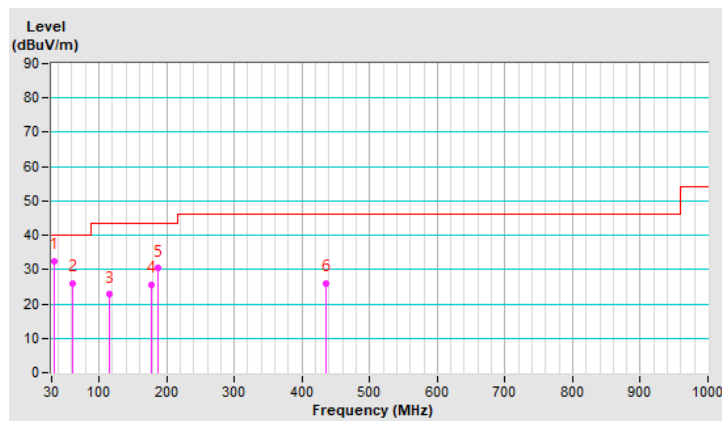

## 4.2 Conducted Emission Measurement

### 4.2.1 Limits of Conducted Emission Measurement

Frequency (MHz)	Conducted Limit (dBuV)	
	Quasi-peak	Average
0.15 - 0.5	66 - 56	56 - 46
0.50 - 5.0	56	46
5.0 - 30.0	60	50

Note: 1. The lower limit shall apply at the transition frequencies.

2. The limit decreases in line with the logarithm of the frequency in the range of 0.15 to 0.50MHz.

### 4.2.2 Test Instruments

DESCRIPTION & MANUFACTURER	MODEL NO.	SERIAL NO.	CALIBRATED DATE	CALIBRATED UNTIL
Test Receiver R&S	ESCS 30	847124/029	Oct. 20, 2020	Oct. 19, 2021
Line-Impedance Stabilization Network (for EUT) R&S	ESH3-Z5	848773/004	Oct. 27, 2020	Oct. 26, 2021
Line-Impedance Stabilization Network (for Peripheral) R&S	ESH3-Z5	835239/001	Mar. 26, 2021	Mar. 25, 2022
50 ohms Terminator	50	3	Oct. 26, 2020	Oct. 25, 2021
RF Cable	5D-FB	COCCAB-001	Sep. 26, 2020	Sep. 25, 2021
Fixed attenuator EMCI	STI02-2200-10	005	Aug. 29, 2020	Aug. 28, 2021
Software BVADT	BVADT_Cond_ V7.3.7.4	NA	NA	NA

**Note:**

1. The calibration interval of the above test instruments are 12 months and the calibrations are traceable to NML/ROC and NIST/USA.
2. The test was performed in Conduction 1.
- 3 Tested Date: July 03, 2021

#### 4.2.3 Test Procedures

- a. The EUT was placed 0.4 meters from the conducting wall of the shielded room with EUT being connected to the power mains through a line impedance stabilization network (LISN). Other support units were connected to the power mains through another LISN. The two LISNs provide 50 ohm/ 50uH of coupling impedance for the measuring instrument.
- b. Both lines of the power mains connected to the EUT were checked for maximum conducted interference.
- c. The frequency range from 150kHz to 30MHz was searched. Emission levels under (Limit - 20dB) was not recorded.

**Note:** The resolution bandwidth and video bandwidth of test receiver is 9kHz for quasi-peak detection (QP) and average detection (AV) at frequency 0.15MHz-30MHz.

#### 4.2.4 Deviation from Test Standard

No deviation.

#### 4.2.5 Test Setup

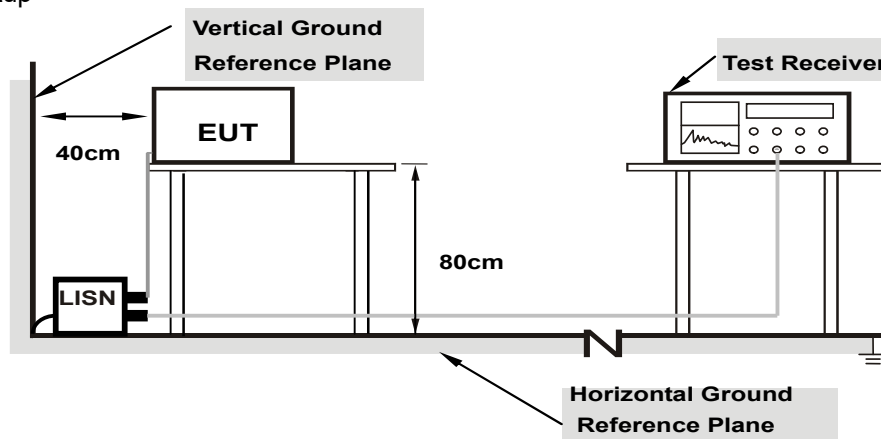

**Note:** 1.Support units were connected to second LISN.

For the actual test configuration, please refer to the attached file (Test Setup Photo).

#### 4.2.6 EUT Operating Conditions

Same as 4.1.6.

#### 4.2.7 Test Results

<b>RF Mode</b>	TX BT-LE 2M	<b>Channel</b>	CH 19 : 2440 MHz
<b>Frequency Range</b>	150kHz ~ 30MHz	<b>Detector Function &amp; Resolution Bandwidth</b>	Quasi-Peak (QP) / Average (AV), 9kHz

Phase Of Power : Line (L)										
No	Frequency (MHz)	Correction Factor (dB)	Reading Value (dBuV)		Emission Level (dBuV)		Limit (dBuV)		Margin (dB)	
			Q.P.	AV.	Q.P.	AV.	Q.P.	AV.	Q.P.	AV.
1	0.15391	9.95	32.31	17.57	42.26	27.52	65.79	55.79	-23.53	-28.27
2	0.20469	9.97	37.30	23.65	47.27	33.62	63.42	53.42	-16.15	-19.80
3	0.38047	9.99	19.79	10.09	29.78	20.08	58.27	48.27	-28.49	-28.19
4	0.70859	10.01	14.78	5.13	24.79	15.14	56.00	46.00	-31.21	-30.86
<b>5</b>	<b>14.83594</b>	<b>10.82</b>	<b>34.53</b>	<b>33.73</b>	<b>45.35</b>	<b>44.55</b>	<b>60.00</b>	<b>50.00</b>	<b>-14.65</b>	<b>-5.45</b>
6	28.93359	11.29	22.24	20.87	33.53	32.16	60.00	50.00	-26.47	-17.84

#### Remarks:

1. Q.P. and AV. are abbreviations of quasi-peak and average individually.
2. The emission levels of other frequencies were very low against the limit.
3. Margin value = Emission level – Limit value
4. Correction factor = Insertion loss + Cable loss
5. Emission Level = Correction Factor + Reading Value

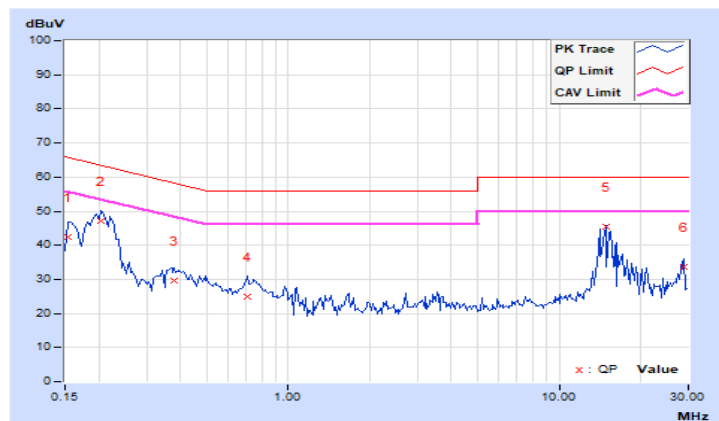



<b>RF Mode</b>	TX BT-LE 2M	<b>Channel</b>	CH 19 : 2440 MHz
<b>Frequency Range</b>	150kHz ~ 30MHz	<b>Detector Function &amp; Resolution Bandwidth</b>	Quasi-Peak (QP) / Average (AV), 9kHz

Phase Of Power : Neutral (N)										
No	Frequency (MHz)	Correction Factor (dB)	Reading Value (dBuV)		Emission Level (dBuV)		Limit (dBuV)		Margin (dB)	
			Q.P.	AV.	Q.P.	AV.	Q.P.	AV.	Q.P.	AV.
1	0.15781	9.92	32.20	18.77	42.12	28.69	65.58	55.58	-23.46	-26.89
2	0.20469	9.95	33.53	21.91	43.48	31.86	63.42	53.42	-19.94	-21.56
3	0.37656	9.96	16.20	6.52	26.16	16.48	58.35	48.35	-32.19	-31.87
4	0.67734	9.98	12.12	0.54	22.10	10.52	56.00	46.00	-33.90	-35.48
5	14.83984	10.63	35.26	33.01	45.89	43.64	60.00	50.00	-14.11	-6.36
6	27.44922	10.91	26.22	24.17	37.13	35.08	60.00	50.00	-22.87	-14.92

**Remarks:**

1. Q.P. and AV. are abbreviations of quasi-peak and average individually.
2. The emission levels of other frequencies were very low against the limit.
3. Margin value = Emission level – Limit value
4. Correction factor = Insertion loss + Cable loss
5. Emission Level = Correction Factor + Reading Value

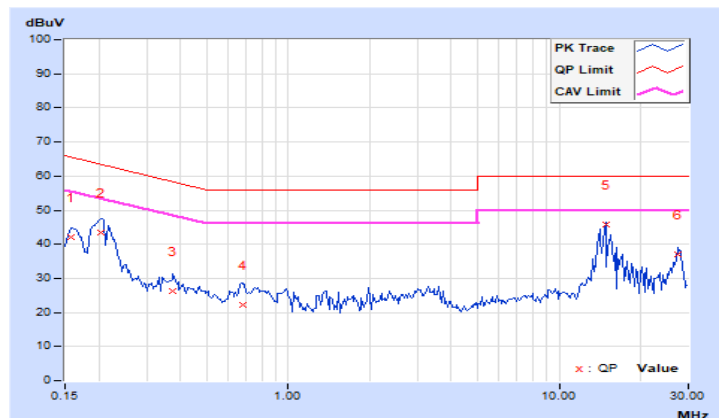

### 4.3 6dB Bandwidth Measurement

#### 4.3.1 Limits of 6dB Bandwidth Measurement

The minimum of 6dB Bandwidth Measurement is 0.5 MHz.

#### 4.3.2 Test Setup

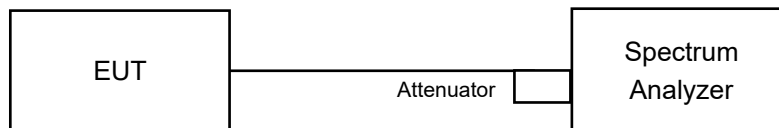

#### 4.3.3 Test Instruments

Refer to section 4.1.2 to get information of above instrument.

#### 4.3.4 Test Procedure

- a. Set resolution bandwidth (RBW) = 100kHz
- b. Set the video bandwidth (VBW)  $\geq 3 \times$  RBW, Detector = Peak.
- c. Trace mode = max hold.
- d. Sweep = auto couple.
- e. Measure the maximum width of the emission that is constrained by the frequencies associated with the two amplitude points (upper and lower) that are attenuated by 6 dB relative to the maximum level measured in the fundamental emission

#### 4.3.5 Deviation from Test Standard

No deviation.

#### 4.3.6 EUT Operating Conditions

The software provided by client to enable the EUT under transmission condition continuously at lowest, middle and highest channel frequencies individually.

### 4.3.7 Test Results

#### BT-LE 1M

Channel	Frequency (MHz)	6dB Bandwidth (MHz)	Minimum Limit (MHz)	Pass / Fail
0	2402	0.68	0.5	Pass
19	2440	0.68	0.5	Pass
39	2480	0.68	0.5	Pass

#### BT-LE 2M

Channel	Frequency (MHz)	6dB Bandwidth (MHz)	Minimum Limit (MHz)	Pass / Fail
0	2402	1.16	0.5	Pass
19	2440	1.16	0.5	Pass
39	2480	1.17	0.5	Pass

Spectrum Plot of Worst Value

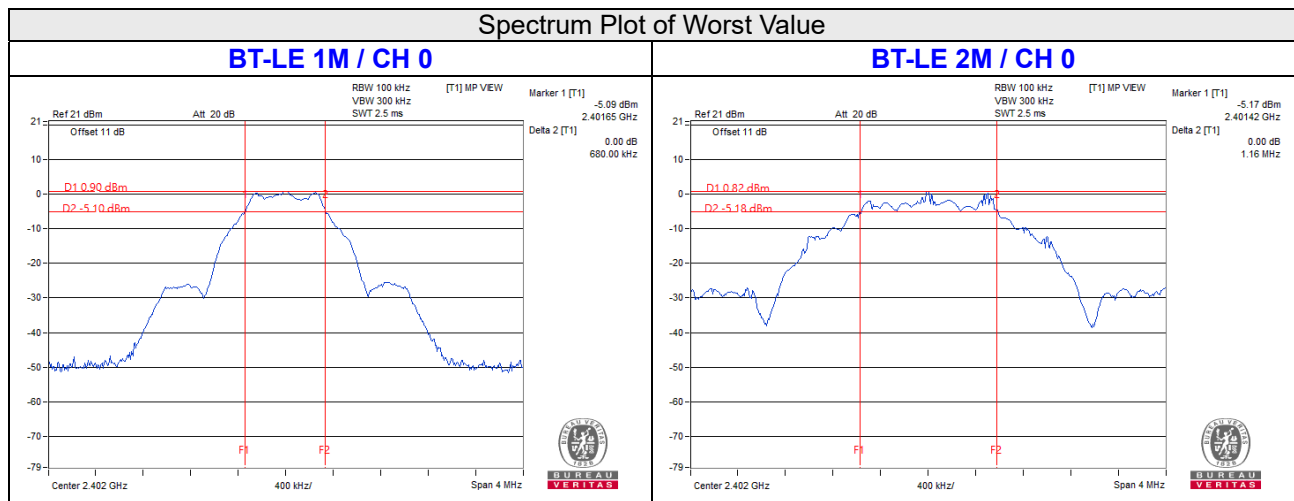

## 4.4 Conducted Output Power Measurement

### 4.4.1 Limits of Conducted Output Power Measurement

For systems using digital modulation in the 2400–2483.5 MHz bands: 1 Watt (30dBm)

### 4.4.2 Test Setup

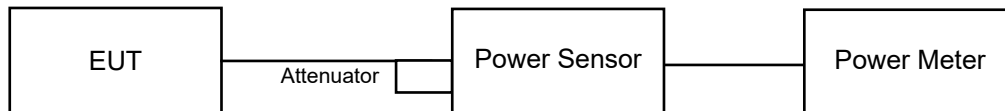

### 4.4.3 Test Instruments

Refer to section 4.1.2 to get information of above instrument.

### 4.4.4 Test Procedures

A peak power sensor was used on the output port of the EUT. A power meter was used to read the response of the peak power sensor. Record the power level.

Average power sensor was used to perform output power measurement, trigger and gating function of wide band power meter is enabled to measure max output power of TX on burst. Duty factor is not added to measured value.

### 4.4.5 Deviation from Test Standard

No deviation.

### 4.4.6 EUT Operating Conditions

Same as Item 4.3.6.

#### 4.4.7 Test Results

##### FOR PEAK POWER

###### BT-LE 1M

Channel	Frequency (MHz)	Peak Power (mW)	Peak Power (dBm)	Limit (dBm)	Pass/Fail
0	2402	1.671	2.23	30	Pass
19	2440	1.73	2.38	30	Pass
39	2480	1.489	1.73	30	Pass

###### BT-LE 2M

Channel	Frequency (MHz)	Peak Power (mW)	Peak Power (dBm)	Limit (dBm)	Pass/Fail
0	2402	1.611	2.07	30	Pass
19	2440	1.722	2.36	30	Pass
39	2480	1.493	1.74	30	Pass

##### FOR AVERAGE POWER

###### BT-LE 1M

Channel	Frequency (MHz)	Average Power (mW)	Average Power (dBm)
0	2402	1.472	1.68
19	2440	1.556	1.92
39	2480	1.33	1.24

###### BT-LE 2M

Channel	Frequency (MHz)	Average Power (mW)	Average Power (dBm)
0	2402	1.462	1.65
19	2440	1.556	1.92
39	2480	1.337	1.26

## 4.5 Power Spectral Density Measurement

### 4.5.1 Limits of Power Spectral Density Measurement

The Maximum of Power Spectral Density Measurement is 8dBm in any 3 kHz.

### 4.5.2 Test Setup

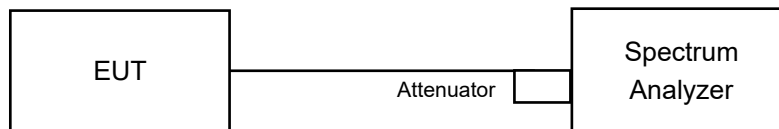

### 4.5.3 Test Instruments

Refer to section 4.1.2 to get information of above instrument.

### 4.5.4 Test Procedure

- a. Set analyzer center frequency to DTS channel center frequency.
- b. Set the span to 1.5 times the DTS bandwidth.
- c. Set the RBW to:  $3 \text{ kHz} \leq \text{RBW} \leq 100 \text{ kHz}$ .
- d. Set the VBW  $\geq 3 \times \text{RBW}$ .
- e. Detector = peak.
- f. Sweep time = auto couple.
- g. Trace mode = max hold.
- h. Allow trace to fully stabilize.
- i. Use the peak marker function to determine the maximum amplitude level within the RBW.

### 4.5.5 Deviation from Test Standard

No deviation.

### 4.5.6 EUT Operating Condition

Same as Item 4.3.6.

#### 4.5.7 Test Results

##### BT-LE 1M

Channel	Freq. (MHz)	PSD (dBm/3kHz)	Limit (dBm/3kHz)	Pass /Fail
0	2402	-13.50	8	Pass
19	2440	-13.13	8	Pass
39	2480	-13.69	8	Pass

##### BT-LE 2M

Channel	Freq. (MHz)	PSD (dBm/3kHz)	Limit (dBm/3kHz)	Pass /Fail
0	2402	-17.59	8	Pass
19	2440	-17.14	8	Pass
39	2480	-17.81	8	Pass

Spectrum Plot of Worst Value

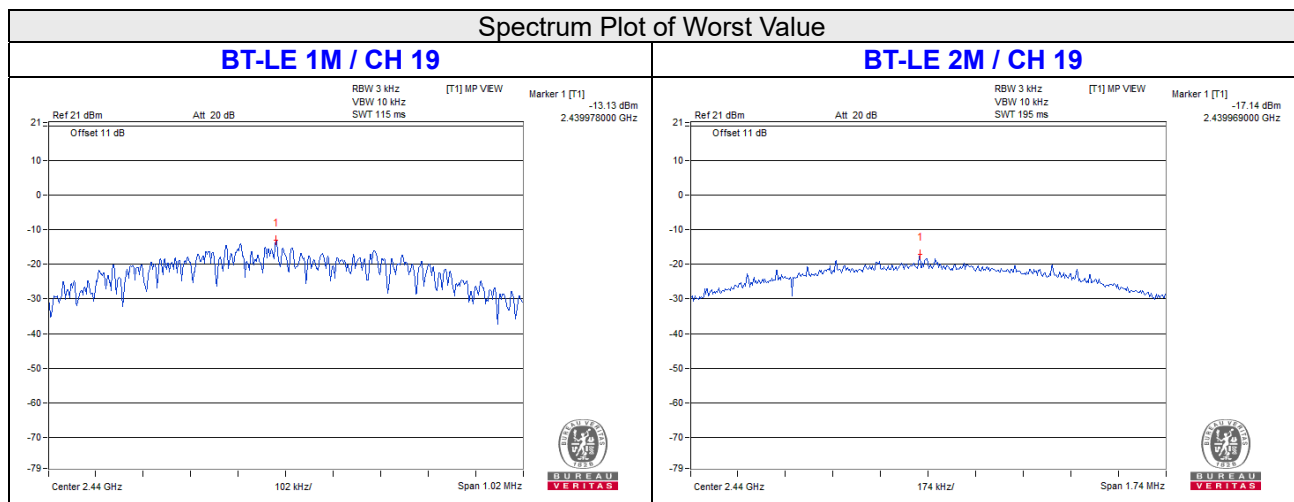

## 4.6 Conducted Out of Band Emission Measurement

### 4.6.1 Limits of Conducted Out of Band Emission Measurement

Below 20dB of the highest emission level of operating band (in 100kHz Resolution Bandwidth).

### 4.6.2 Test Setup

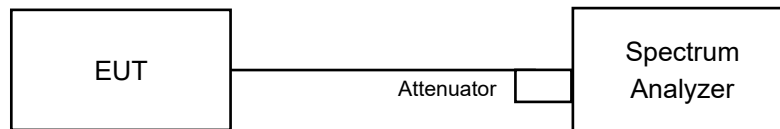

### 4.6.3 Test Instruments

Refer to section 4.1.2 to get information of above instrument.

### 4.6.4 Test Procedure

#### MEASUREMENT PROCEDURE REF

1. Set the RBW = 100 kHz.
2. Set the VBW  $\geq$  300 kHz.
3. Detector = peak.
4. Sweep time = auto couple.
5. Trace mode = max hold.
6. Allow trace to fully stabilize.
7. Use the peak marker function to determine the maximum power level in any 100 kHz band segment within the fundamental EBW.

#### MEASUREMENT PROCEDURE OOBE

1. Set RBW = 100 kHz.
2. Set VBW  $\geq$  300 kHz.
3. Detector = peak.
4. Sweep = auto couple.
5. Trace Mode = max hold.
6. Allow trace to fully stabilize.
7. Use the peak marker function to determine the maximum amplitude level.

### 4.6.5 Deviation from Test Standard

No deviation.

### 4.6.6 EUT Operating Condition

The software provided by client enabled the EUT to transmit and receive data at lowest, middle and highest channel frequencies individually.

### 4.6.7 Test Results

The spectrum plots are attached on the following pages. D1 line indicates the highest level, and D2 line indicates the 20dB offset below D1. It shows compliance with the requirement.



**BT-LE 1M**

**CH 0**

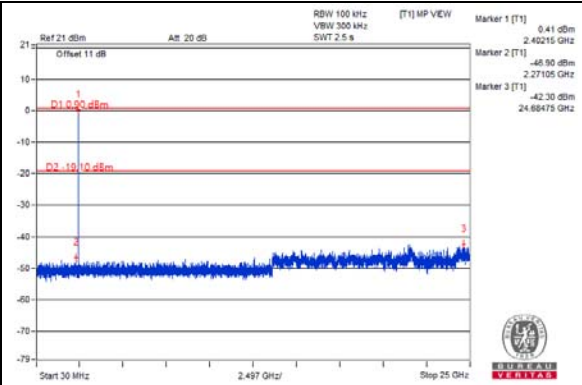
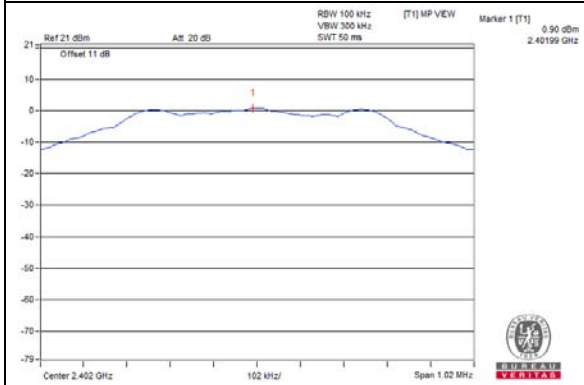

**CH 19**

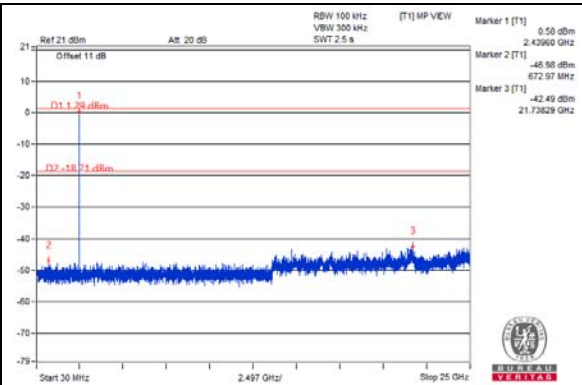
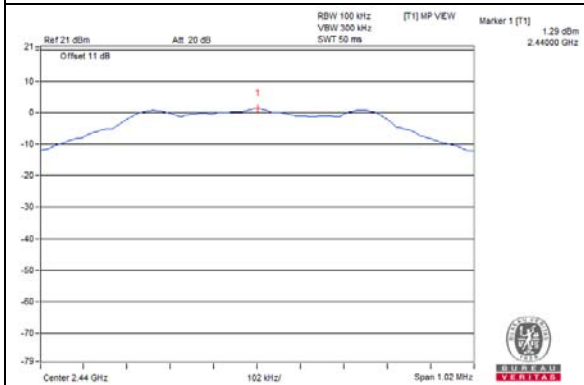

**CH 39**

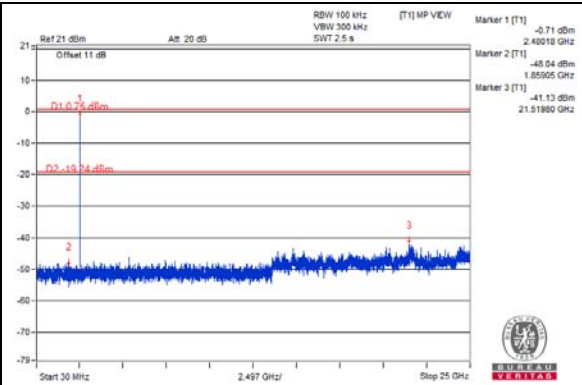
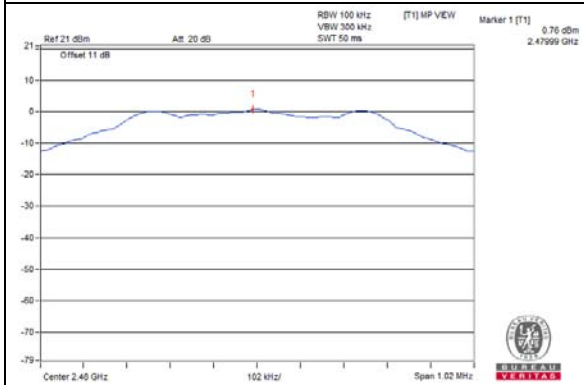

**CH 0 Band edge**

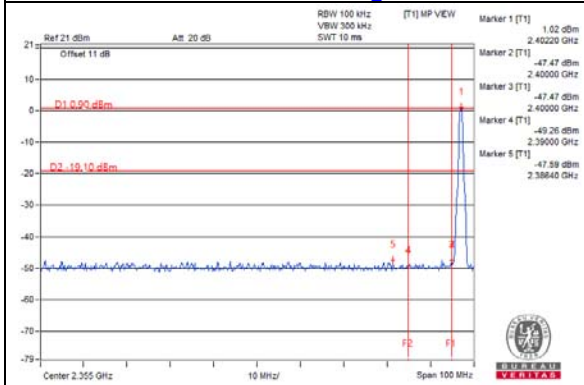

**CH 39 Band edge**

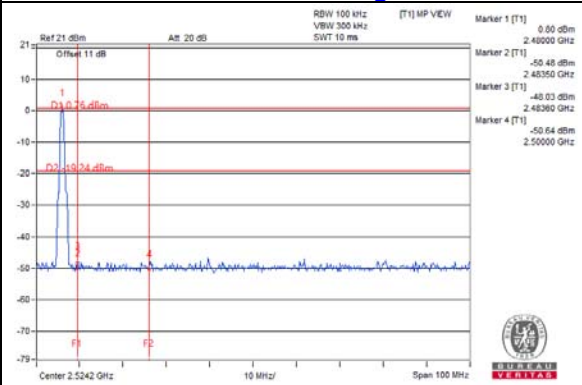

**BT-LE 2M**

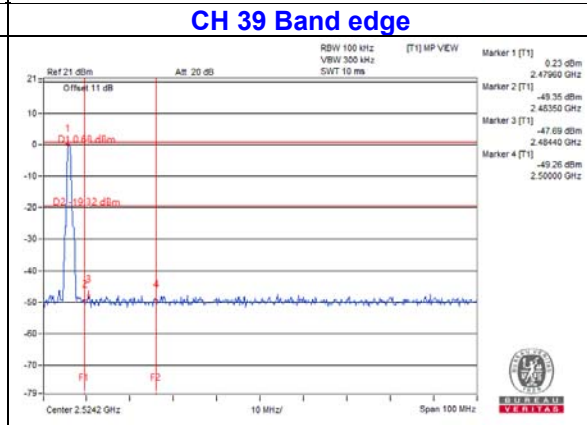
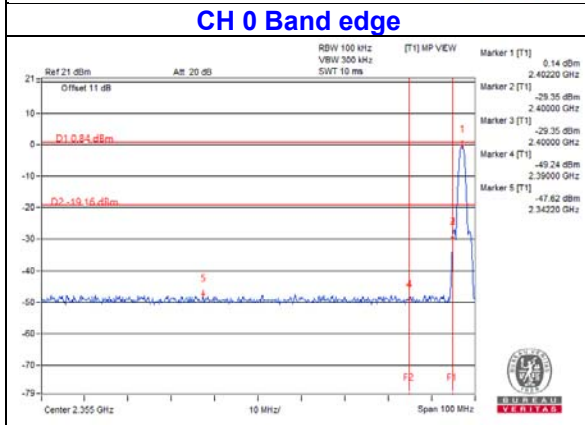
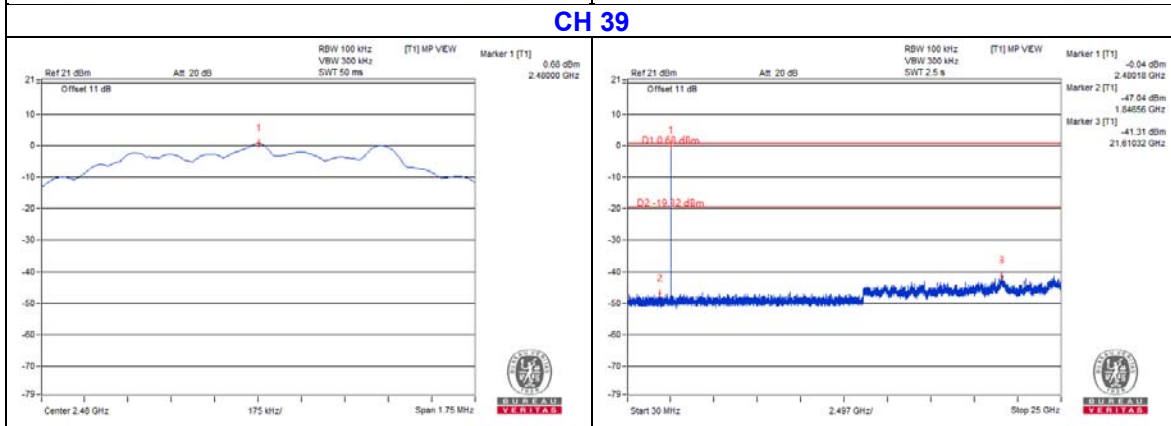
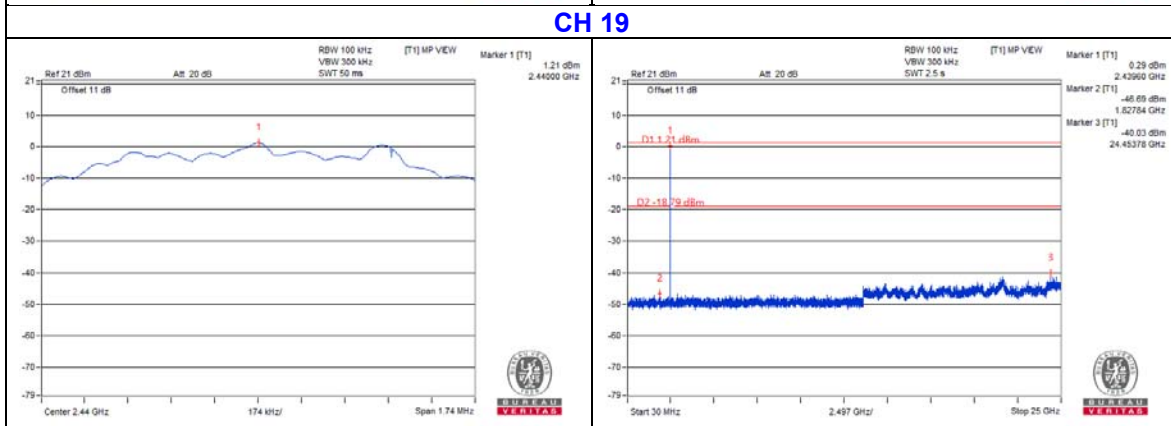
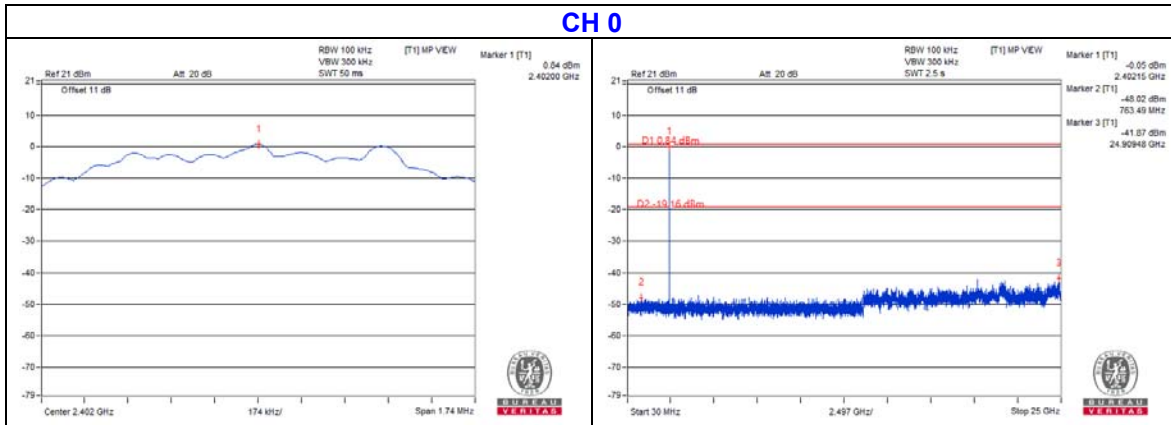

## 5 Pictures of Test Arrangements

Please refer to the attached file (Test Setup Photo).

# Annex A - Band-Edge Measurement

## BT-LE 1M

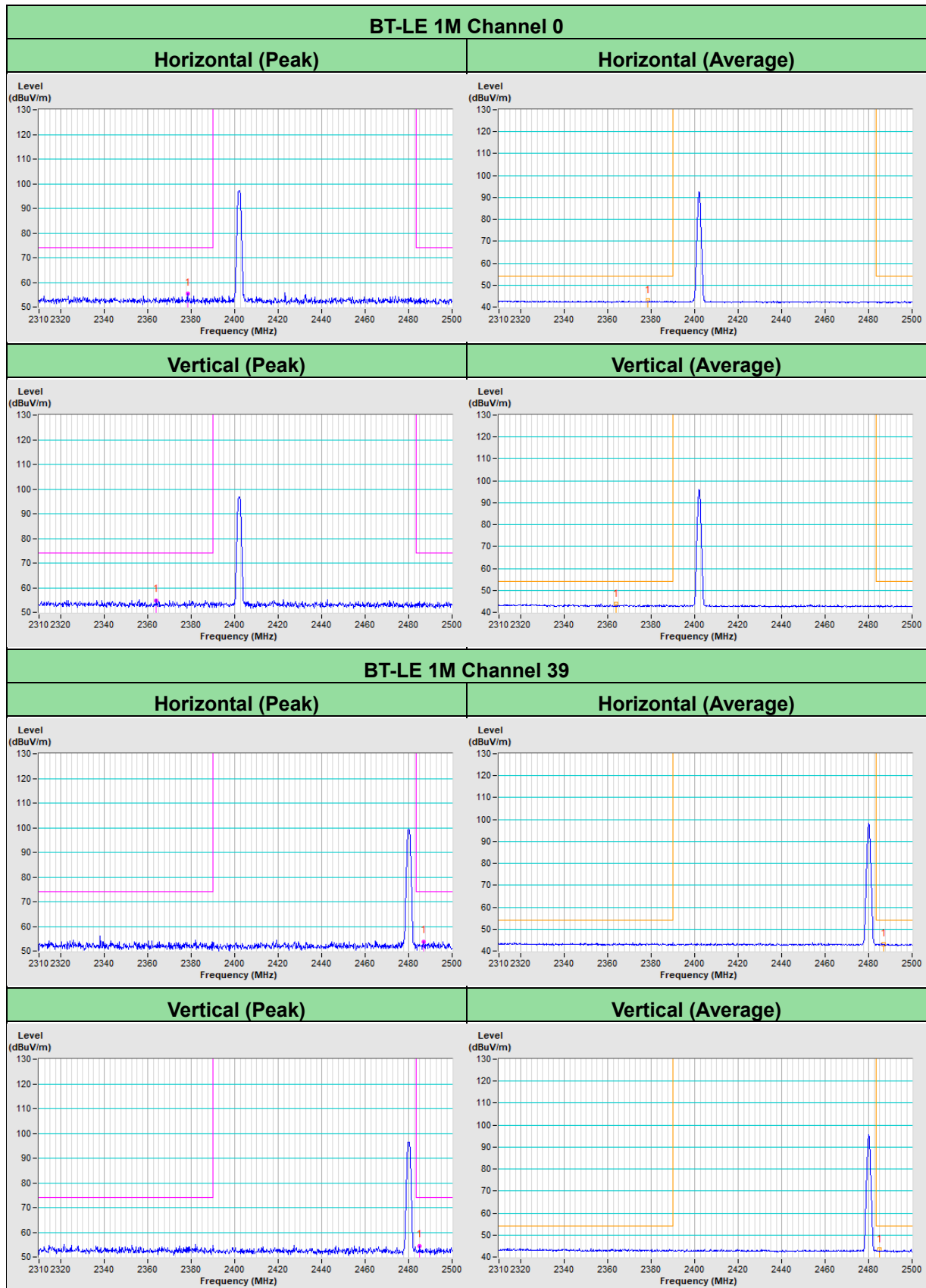

**BT-LE 2M**

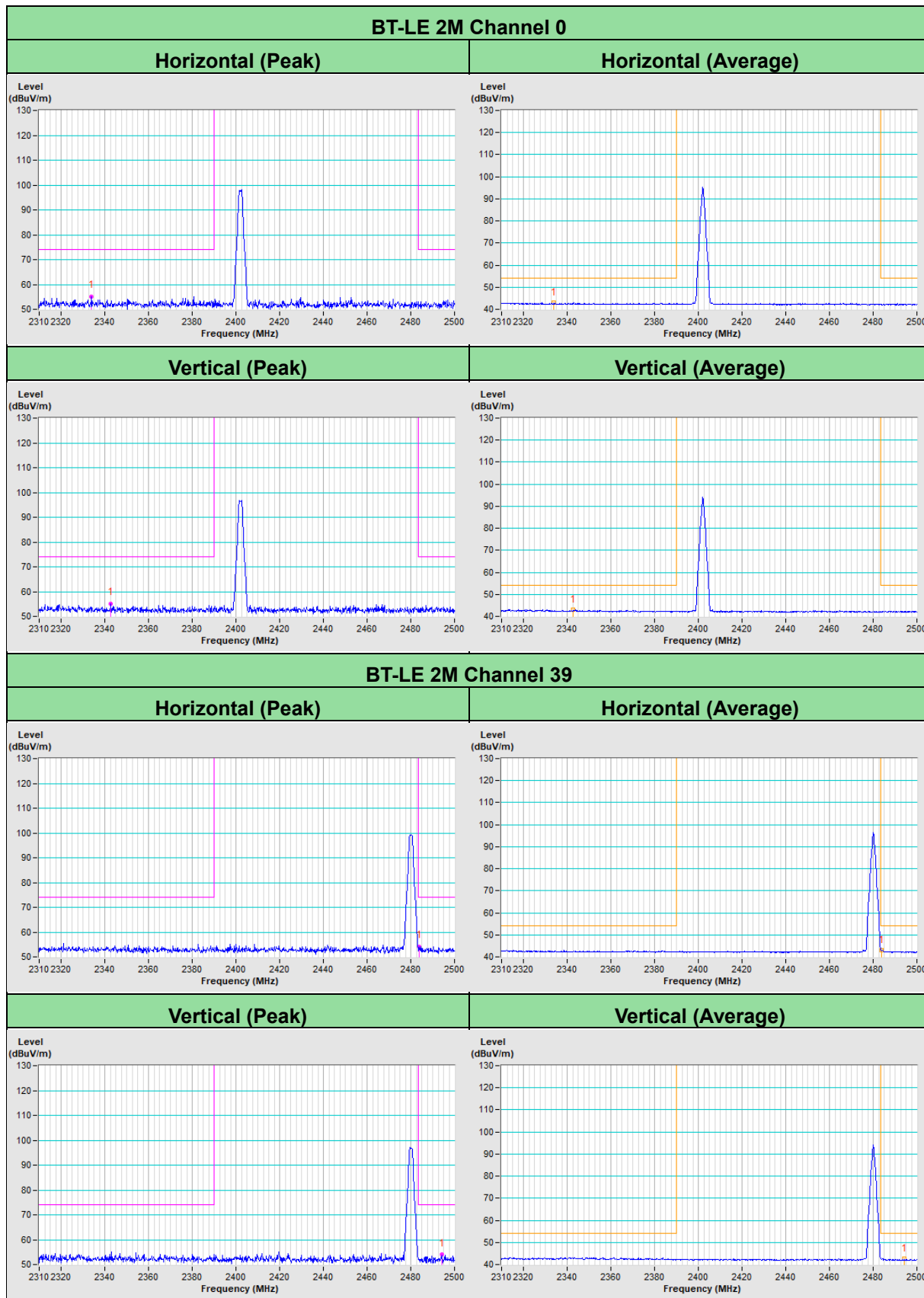

## Appendix – Information of the Testing Laboratories

We, Bureau Veritas Consumer Products Services (H.K.) Ltd., Taoyuan Branch, were founded in 1988 to provide our best service in EMC, Radio, Telecom and Safety consultation. Our laboratories are FCC recognized accredited test firms and accredited according to ISO/IEC 17025.

If you have any comments, please feel free to contact us at the following:

**Lin Kou EMC/RF Lab**

Tel: 886-2-26052180

Fax: 886-2-26051924

**Hsin Chu EMC/RF/Telecom Lab**

Tel: 886-3-6668565

Fax: 886-3-6668323

**Hwa Ya EMC/RF/Safety Lab**

Tel: 886-3-3183232

Fax: 886-3-3270892

**Email:** [service.adt@tw.bureauveritas.com](mailto:service.adt@tw.bureauveritas.com)

**Web Site:** [www.bureauveritas-adt.com](http://www.bureauveritas-adt.com)

The address and road map of all our labs can be found in our web site also.

--- END ---