



# **TEST REPORT**

**Report Number. :** 13426664-E2V3

**Applicant :** LOGITECH INC.  
7700 GATEWAY BLVD,  
NEWARK, CA 94560, U.S.A.

**Model :** VR0014

**FCC ID :** JNZVR0014

**EUT Description :** DOORBELL

**Test Standard(s) :** FCC 47 CFR PART 15 SUBPART E

**Date Of Issue:**

October 30, 2020

**Prepared by:**

UL Verification Services Inc.  
47173 Benicia Street  
Fremont, CA 94538 U.S.A.  
TEL: (510) 319-4000  
FAX: (510) 661-0888



NVLAP Lab code: 200065-0

---

## REPORT REVISION HISTORY

Rev.	Issue Date	Revisions	Revised By
V1	10/13/2020	Initial Issue	--
V2	10/20/2020	Updated report to address TCB's questions	Tina Chu
V3	10/30/2020	Corrected firwmware version	Tina Chu

## TABLE OF CONTENTS

<b>REPORT REVISION HISTORY .....</b>	<b>2</b>
<b>TABLE OF CONTENTS .....</b>	<b>3</b>
<b>1. ATTESTATION OF TEST RESULTS .....</b>	<b>6</b>
<b>2. TEST RESULT SUMMARY .....</b>	<b>8</b>
<b>3. TEST METHODOLOGY .....</b>	<b>8</b>
<b>4. FACILITIES AND ACCREDITATION .....</b>	<b>9</b>
<b>5. DECISION RULES AND MEASUREMENT UNCERTAINTY .....</b>	<b>10</b>
5.1. METROLOGICAL TRACEABILITY .....	10
5.2. DECISION RULES.....	10
5.3. MEASUREMENT UNCERTAINTY.....	10
5.4. SAMPLE CALCULATION .....	10
<b>6. EQUIPMENT UNDER TEST .....</b>	<b>11</b>
6.1. EUT DESCRIPTION .....	11
6.2. MAXIMUM OUTPUT POWER.....	11
6.3. DESCRIPTION OF AVAILABLE ANTENNAS .....	12
6.4. SOFTWARE AND FIRMWARE.....	12
6.5. WORST-CASE CONFIGURATION AND MODE.....	13
6.6. DESCRIPTION OF TEST SETUP.....	14
<b>7. MEASUREMENT METHOD.....</b>	<b>19</b>
<b>8. TEST AND MEASUREMENT EQUIPMENT .....</b>	<b>20</b>
<b>9. ANTENNA PORT TEST RESULTS .....</b>	<b>21</b>
9.1. ON TIME AND DUTY CYCLE.....	21
9.2. 26 dB BANDWIDTH.....	23
9.2.1. 802.11n HT20 MODE IN THE 5.2 GHz BAND .....	23
9.2.2. 802.11n HT40 MODE IN THE 5.2 GHz BAND .....	25
9.2.3. 802.11ac VHT80 MODE IN THE 5.2 GHz BAND .....	26
9.2.4. 802.11n HT20 MODE IN THE 5.3 GHz BAND .....	27
9.2.5. 802.11n HT40 MODE IN THE 5.3 GHz BAND .....	29
9.2.6. 802.11ac VHT80 MODE IN THE 5.3 GHz BAND .....	30
9.2.7. 802.11n HT20 MODE IN THE 5.6 GHz BAND .....	31
9.2.8. 802.11n HT40 MODE IN THE 5.6 GHz BAND .....	33
9.2.9. 802.11ac VHT80 MODE IN THE 5.6 GHz BAND .....	35

9.2.10.	802.11n HT20 MODE IN THE 5.8 GHz BAND .....	37
9.2.11.	802.11n HT40 MODE IN THE 5.8 GHz BAND .....	39
9.2.12.	802.11ac VHT80 MODE IN THE 5.8 GHz BAND .....	40
9.3.	99% BANDWIDTH.....	41
9.3.1.	802.11n HT20 MODE IN THE 5.2 GHz BAND .....	41
9.3.2.	802.11n HT40 MODE IN THE 5.2 GHz BAND .....	43
9.3.3.	802.11ac VHT80 MODE IN THE 5.2 GHz BAND .....	44
9.3.4.	802.11n HT20 MODE IN THE 5.3 GHz BAND .....	45
9.3.5.	802.11n HT40 MODE IN THE 5.3 GHz BAND .....	47
9.3.6.	802.11ac VHT80 MODE IN THE 5.3 GHz BAND .....	48
9.3.7.	802.11n HT20 MODE IN THE 5.6 GHz BAND .....	49
9.3.8.	802.11n HT40 MODE IN THE 5.6 GHz BAND .....	51
9.3.9.	802.11ac VHT80 MODE IN THE 5.6 GHz BAND .....	53
9.3.10.	802.11n HT20 MODE IN THE 5.8 GHz BAND .....	55
9.3.11.	802.11n HT40 MODE IN THE 5.8 GHz BAND .....	57
9.3.12.	802.11ac VHT80 MODE IN THE 5.8 GHz BAND .....	58
9.4.	6 dB BANDWIDTH.....	59
9.4.1.	802.11n HT20 MODE IN THE 5.8 GHz BAND .....	59
9.4.2.	802.11n HT40 MODE IN THE 5.8 GHz BAND .....	62
9.4.3.	802.11ac VHT80 MODE IN THE 5.8 GHz BAND .....	64
9.5.	OUTPUT POWER AND PSD.....	65
9.5.1.	802.11n HT20 MODE IN THE 5.2 GHz BAND .....	67
9.5.2.	802.11n HT40 MODE IN THE 5.2 GHz BAND .....	70
9.5.3.	802.11ac VHT80 MODE IN THE 5.2 GHz BAND .....	72
9.5.4.	802.11n HT20 MODE IN THE 5.3 GHz BAND .....	73
9.5.5.	802.11n HT40 MODE IN THE 5.3 GHz BAND .....	76
9.5.6.	802.11ac VHT80 MODE IN THE 5.3 GHz BAND .....	78
9.5.7.	802.11n HT20 MODE IN THE 5.6 GHz BAND .....	79
9.5.8.	802.11n HT40 MODE IN THE 5.6 GHz BAND .....	82
9.5.9.	802.11ac VHT80 MODE IN THE 5.6 GHz BAND .....	85
9.5.10.	802.11n HT20 MODE IN THE 5.8 GHz BAND .....	88
9.5.11.	802.11n HT40 MODE IN THE 5.8 GHz BAND .....	91
9.5.12.	802.11ac VHT80 MODE IN THE 5.8 GHz BAND .....	93
<b>10.</b>	<b>RADIATED TEST RESULTS.....</b>	<b>94</b>
10.1.	TRANSMITTER ABOVE 1 GHz.....	96
10.1.1.	TX ABOVE 1 GHz 802.11n HT20 MODE IN THE 5.2 GHz BAND.....	96
10.1.2.	TX ABOVE 1 GHz 802.11n HT40 MODE IN THE 5.2 GHz BAND.....	104
10.1.3.	TX ABOVE 1 GHz 802.11ac VHT80 MODE IN THE 5.2 GHz BAND.....	110
10.1.4.	TX ABOVE 1 GHz 802.11n HT20 MODE IN THE 5.3 GHz BAND.....	114
10.1.5.	TX ABOVE 1 GHz 802.11n HT40 MODE IN THE 5.3 GHz BAND.....	122
10.1.6.	TX ABOVE 1 GHz 802.11ac VHT80 MODE IN THE 5.3 GHz BAND.....	128
10.1.7.	TX ABOVE 1 GHz 802.11n HT20 MODE IN THE 5.6 GHz BAND.....	132
10.1.8.	TX ABOVE 1 GHz 802.11n HT40 MODE IN THE 5.6 GHz BAND.....	144
10.1.9.	TX ABOVE 1 GHz 802.11ac VHT80 MODE IN THE 5.6 GHz BAND.....	156
10.1.10.	TX ABOVE 1 GHz 802.11n HT20 MODE IN THE 5.8 GHz BAND.....	166
10.1.11.	TX ABOVE 1 GHz 802.11n HT40 MODE IN THE 5.8 GHz BAND.....	176
10.1.12.	TX ABOVE 1 GHz 802.11ac VHT80 MODE IN THE 5.8 GHz BAND.....	184
10.2.	WORST CASE BELOW 30MHZ.....	190

---

10.3.	WORST CASE BELOW 1 GHZ.....	191
10.4.	WORST CASE 18-26 GHZ.....	193
10.5.	WORST CASE 26-40 GHZ.....	195
<b>11.</b>	<b>AC POWER LINE CONDUCTED EMISSIONS.....</b>	<b>197</b>
<b>12.</b>	<b>SETUP PHOTOS.....</b>	<b>200</b>

# 1. ATTESTATION OF TEST RESULTS

**COMPANY NAME:** LOGITECH INC.  
7700 GATEWAY BLVD,  
NEWARK, CA 94560, U.S.A.

**EUT DESCRIPTION:** DOORBELL

**MODEL:** VR0014

**SERIAL NUMBER:** 2031LZN1G3W8 (CONDUCTED)  
2031LZN1FXL8; 2031LZN1FXC8(RADIATED)

**DATE TESTED:** SEPTEMBER 16, 2020 – OCTOBER 01, 2020

APPLICABLE STANDARDS	
STANDARD	TEST RESULTS
CFR 47 Part 15 Subpart E	Complies

UL Verification Services Inc. tested the above equipment in accordance with the requirements set forth in the above standards. The test results show that the equipment tested is capable of demonstrating compliance with the requirements as documented in this report.

The results documented in this report apply only to the tested sample, under the conditions and modes of operation as described herein. It is the manufacturer's responsibility to assure that additional production units of this model are manufactured with identical electrical and mechanical components. All samples tested were in good operating condition throughout the entire test program. Measurement Uncertainties are published for informational purposes only and were not taken into account unless noted otherwise.

This document may not be altered or revised in any way unless done so by UL Verification Services Inc. and all revisions are duly noted in the revisions section. Any alteration of this document not carried out by UL Verification Services Inc. will constitute fraud and shall nullify the document. This report must not be used by the client to claim product certification, approval, or endorsement by NVLAP, NIST, any agency of the Federal Government, or any agency of the U.S. government.

Approved & Released For  
UL Verification Services Inc. By:

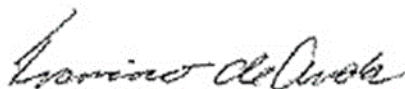

---

Francisco de Anda  
STAFF ENGINEER  
UL Verification Services Inc.

Prepared By:



---

Eric Yu  
TEST ENGINEER  
UL Verification Services Inc.

Reviewed By:

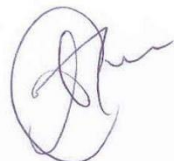

---

Tina Chu  
SENIOR PROJECT ENGINEER  
UL Verification Services Inc.

## 2. TEST RESULT SUMMARY

FCC Clause	Requirement	Result	Comment
See Comment	Duty Cycle	Reporting purposes only	Per ANSI C63.10, Section 12.2.
See Comment	26dB BW/99% OBW	Reporting purposes only	Per ANSI C63.10 Sections 6.9.2 and 6.9.3
15.407 (e)	6 dB BW	Complies	None.
15.407 (a) (1-3), (h) (1)	Output Power	Complies	None.
15.407 (a) (1-3)	PSD	Complies	None.
15.209, 15.205, 15.407 (b)	Radiated Emissions	Complies	None.
15.207	AC Mains Conducted Emissions	Complies	None.

## 3. TEST METHODOLOGY

The tests documented in this report were performed in accordance with;

- FCC CFR 47 Part 2
- FCC CFR 47 Part 15
- FCC KDB 662911 D01 v02r01
- FCC KDB 905462 D02 v02/D03 v01r02/D06 v02
- FCC KDB 789033 D02 v02r01
- ANSI C63.10-2013



## 4. FACILITIES AND ACCREDITATION

The test sites and measurement facilities used to collect data are located at 47173 and 47266 Benicia Street, and 47658 Kato Road, Fremont, California, USA. Line conducted emissions were measured at 47658 Kato Road address. The following table identifies which facilities were utilized for radiated emission measurements documented in this report. Specific facilities are also identified in the test results sections.

47173 Benicia Street	47266 Benicia Street	47658 Kato Rd
<input type="checkbox"/> Chamber A	<input type="checkbox"/> Chamber D	<input type="checkbox"/> Chamber I
<input type="checkbox"/> Chamber B	<input type="checkbox"/> Chamber E	<input type="checkbox"/> Chamber J
<input type="checkbox"/> Chamber C	<input type="checkbox"/> Chamber F	<input checked="" type="checkbox"/> Chamber K
	<input type="checkbox"/> Chamber G	<input type="checkbox"/> Chamber L
	<input type="checkbox"/> Chamber H	<input type="checkbox"/> Chamber M

The above test sites and facilities are covered under FCC Test Firm Registration # 208313. Chambers above are covered under Industry Canada company address and respective code: 2324B.

UL Verification Services Inc. is accredited by NVLAP, Laboratory Code 200065-0

## 5. DECISION RULES AND MEASUREMENT UNCERTAINTY

### 5.1. METROLOGICAL TRACEABILITY

All test and measuring equipment utilized to perform the tests documented in this report are calibrated on a regular basis, with a maximum time between calibrations of one year or the manufacturers' recommendation, whichever is less, and where applicable is traceable to recognized national standards.

### 5.2. DECISION RULES

The Decision Rule is based on Simple Acceptance in accordance with ISO Guide 98-4:2012 Clause 8.2. (Measurement uncertainty is not taken into account when stating conformity with a specified requirement.)

### 5.3. MEASUREMENT UNCERTAINTY

Where relevant, the following measurement uncertainty levels have been estimated for tests performed on the apparatus:

PARAMETER	U <sub>Lab</sub>
Worst Case Conducted Disturbance, 9KHz to 0.15 MHz	3.39 dB
Worst Case Conducted Disturbance, 0.15 to 30 MHz	3.07 dB
Worst Case Radiated Disturbance, 9KHz to 30 MHz	2.52 dB
Worst Case Radiated Disturbance, 30 to 1000 MHz	4.88 dB
Worst Case Radiated Disturbance, 1000 to 18000 MHz	4.26 dB
Worst Case Radiated Disturbance, 18000 to 26000 MHz	4.39 dB
Worst Case Radiated Disturbance, 26000 to 40000 MHz	5.19 dB

Uncertainty figures are valid to a confidence level of 95%.

### 5.4. SAMPLE CALCULATION

#### **RADIATED EMISSIONS**

Where relevant, the following sample calculation is provided:

Field Strength (dBuV/m) = Measured Voltage (dBuV) + Antenna Factor (dB/m) + Cable Loss (dB) – Preamp Gain (dB)

$$36.5 \text{ dBuV} + 18.7 \text{ dB/m} + 0.6 \text{ dB} - 26.9 \text{ dB} = 28.9 \text{ dBuV/m}$$

#### **MAINS CONDUCTED EMISSIONS**

Where relevant, the following sample calculation is provided:

Final Voltage (dBuV) = Measured Voltage (dBuV) + Cable Loss (dB) + Limiter Factor (dB) + LISN Insertion Loss.

$$36.5 \text{ dBuV} + 0 \text{ dB} + 10.1 \text{ dB} + 0 \text{ dB} = 46.6 \text{ dBuV}$$

## 6. EQUIPMENT UNDER TEST

### 6.1. EUT DESCRIPTION

The EUT is an outdoor doorbell with camera and 2.4G b/g/n HT20, 5G a/n HT20/HT40, 5G ac VHT20/VHT40/VHT80 2x2 radios, wall mounted device.

### 6.2. MAXIMUM OUTPUT POWER

The transmitter has a maximum conducted output power as follows:

#### 5.2 GHz BAND

Frequency Range (MHz)	Mode	Output Power (dBm)	Output Power (mW)
<b>5.2 GHz band, 2TX</b>			
5180-5240	802.11n HT20	17.15	51.88
5190-5230	802.11n HT40	17.39	54.83
5210	802.11ac VHT80	11.23	13.27

#### 5.3 GHz BAND

Frequency Range (MHz)	Mode	Output Power (dBm)	Output Power (mW)
<b>5.3 GHz band, 2TX</b>			
5260 - 5320	802.11n HT20	17.91	61.80
5270 - 5310	802.11n HT40	18.04	63.68
5290	802.11ac VHT80	14.07	25.53

#### 5.6 GHz BAND

Frequency Range (MHz)	Mode	Output Power (dBm)	Output Power (mW)
<b>5.6 GHz band, 2TX</b>			
5500-5720	802.11n HT20	19.10	81.28
5510-5710	802.11n HT40	19.35	86.10
5530-5690	802.11ac VHT80	18.99	79.25

**5.8 GHz BAND**

Frequency Range (MHz)	Mode	Output Power (dBm)	Output Power (mW)
<b>5.8 GHz band, 2TX</b>			
5745-5825	802.11n HT20	18.88	77.27
5755-5795	802.11n HT40	19.42	87.50
5775	802.11ac VHT80	15.77	37.76

**6.3. DESCRIPTION OF AVAILABLE ANTENNAS**

The radio utilizes two PCB monopoles antennas, with a maximum gain of:

Frequency (GHz)	Peak Antenna Gain (dBi)	
	Antenna 1	Antenna 2
5150-5250	1.79	3.14
5250-5350	1.92	3.18
5470-5725	4.16	4.21
5725-5850	3.88	4.86

**6.4. SOFTWARE AND FIRMWARE**

The EUT firmware installed during testing was 7.35

The test utility software used during testing was Putty Release 0.70

---

## 6.5. WORST-CASE CONFIGURATION AND MODE

Radiated emissions below 1GHz, above 18GHz, and power line conducted emission were performed with the EUT set to transmit at the channel with highest output power as worst-case scenario.

Band edge and radiated emissions between 1GHz and 18GHz were performed with the EUT set to transmit at the highest power on low, middle and high channels.

The EUT is a wall mounted device and only has one position which is portrait. Therefore, all final radiated testing was performed with the EUT in portrait orientation.

802.11a mode is covered by 802.11n HT20 mode since it has the same power as HT20. Worst-case data rates as provided by the client were:

802.11a mode: 6 Mbps  
802.11n HT20 mode: MCS0  
802.11n HT40 mode: MCS0  
802.11ac VHT20 mode: MCS0  
802.11ac VHT40 mode: MCS0  
802.11ac VHT80 mode: MCS0

802.11ac VHT20 and VHT40 mode are different from 802.11n HT20 and HT40 only in control messages and have the same power settings.

## 6.6. DESCRIPTION OF TEST SETUP

SUPPORT TEST EQUIPMENT						
Description	Manufacturer	Model	Serial Number	FCC ID/ DoC		
Laptop	Dell	Latitude E7240	669002989NB001	DoC		
Laptop AC/DC adapter	Dell	LP90PM111	CN-0Y4M8K-72438-32Q-5B21-A00	DoC		
Debug board	Logitech	210-002122_003	Version 003	DoC		
BellTransformer	Heath-Zenith	ZT-125	Not available	N/A		
Chime Box	Dongguan Smart Hero Electronic Products Co Ltd	3101-HD	Not available	N/A		
Chime Kit	Logitech	Z00008	C280	DoC		
I/O CABLES (RF CONDUCTED TEST)						
Cable No.	Port	# of Identical Ports	Connector Type	Cable Type	Cable Length (m)	Remarks
1	AC	1	AC	Un-shielded	1	AC Mains to AC/DC Adapter
2	DC	1	DC	Shielded	1.5	AC/DC Adapter to Laptop
3	USB	1	UART	Shielded	1.5	EUT to Laptop
4	Antenna	1	SMA	Un-shielded	1.1	To spectrum analyzer
I/O CABLES (RF RADIATED TEST)						
Cable No.	Port	# of Identical Ports	Connector Type	Cable Type	Cable Length (m)	Remarks
1	AC	1	AC	Un-shielded	1	
2	DC	1	DC	Shielded	1.5	AC/DC Adapter to Laptop
3	USB	1	USB	Shielded	1	Laptop to debug board
3 (b)	USB	1	USB	Shielded	10	Laptop to debug board
4	USB	1	USB to Serial	Un-shielded	1	Debug board to EUT
5	AC	1	AC	Un-shielded	1	
6	DC	1	DC	Un-shielded	1.5	AC/DC Adapter to debug board
I/O CABLES (AC LINE CONDUCTED)						
Cable No.	Port	# of Identical Ports	Connector Type	Cable Type	Cable Length (m)	Remarks
1	AC	1	AC	Un-shielded	0.2	
2	AC	1	AC	Un-shielded	2.0	Transformer -AC to EUT and Chime Kit
3	AC	1	AC	Un-shielded	0.2	Chime kit to chime box

**TEST SETUP-CONDUCTED TEST**

The EUT was connected to the test laptop via USB cable. Test software exercised the EUT.

**SETUP DIAGRAM**

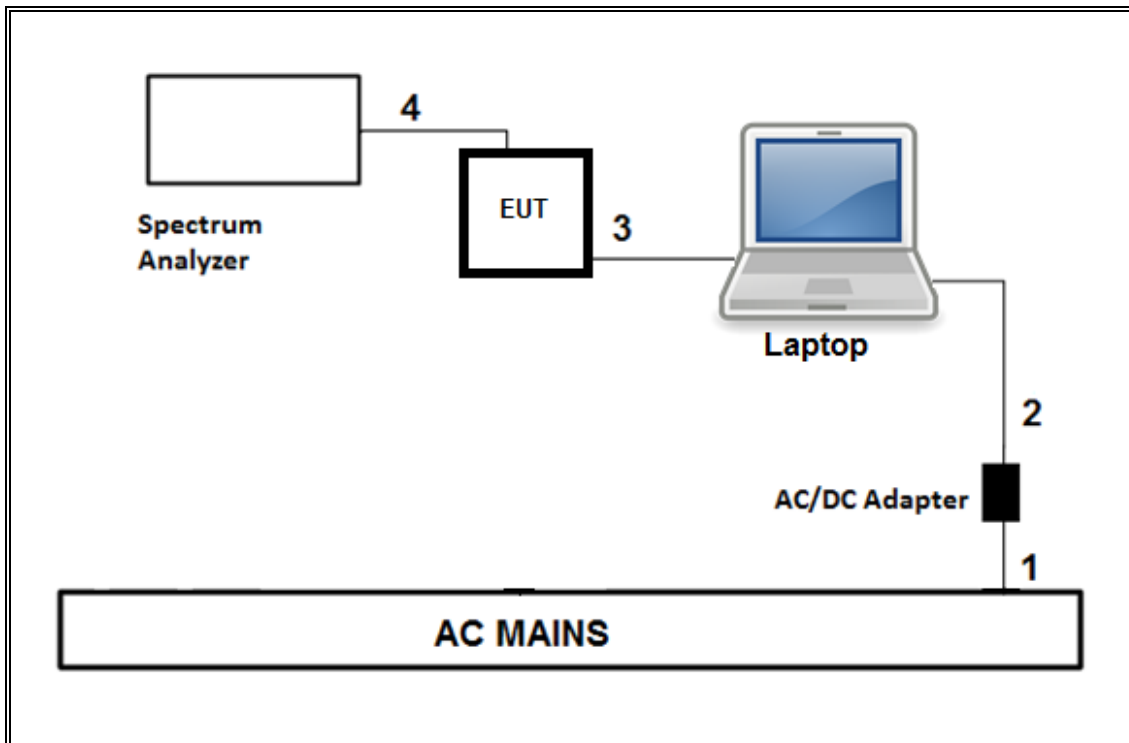

**TEST SETUP- RADIATED TEST ABOVE 1GHz**

The EUT was connected to laptop via debug board. Test software exercised the EUT.

**SETUP DIAGRAM**

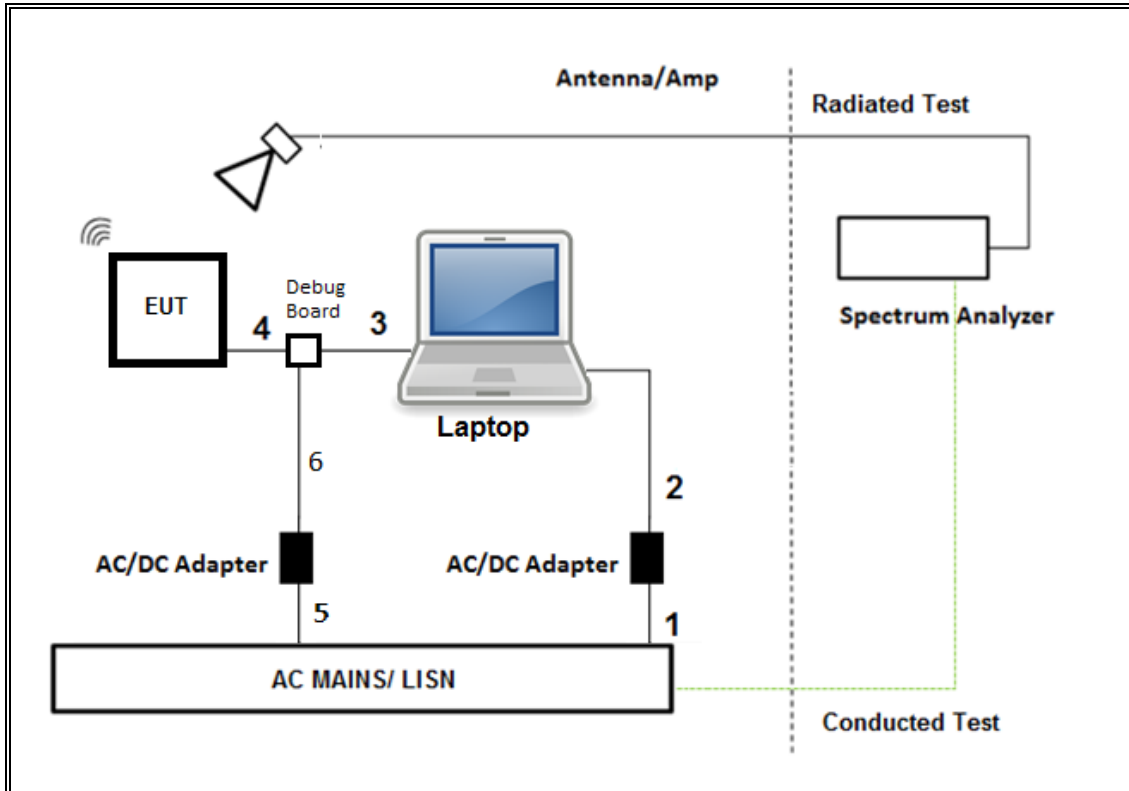



**TEST SETUP- RADIATED TEST FOR BELOW 1GHz TEST**

The EUT was connected to laptop via debug board. Test laptop was outside of the chamber. Test software exercised the EUT.

**SETUP DIAGRAM**

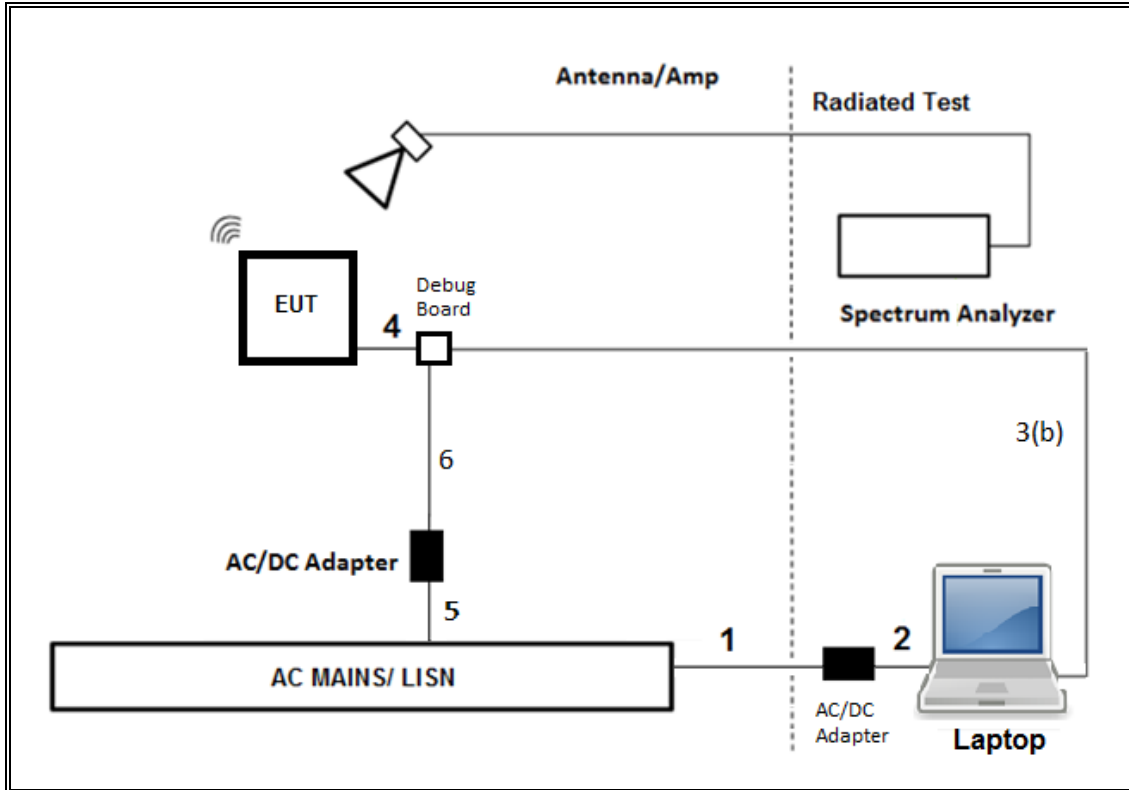

**TEST SETUP- AC LINE CONDUCTED TEST**

The EUT was connected Chime Kit, powered by a transformer. Test software exercised the EUT.

**SETUP DIAGRAM**

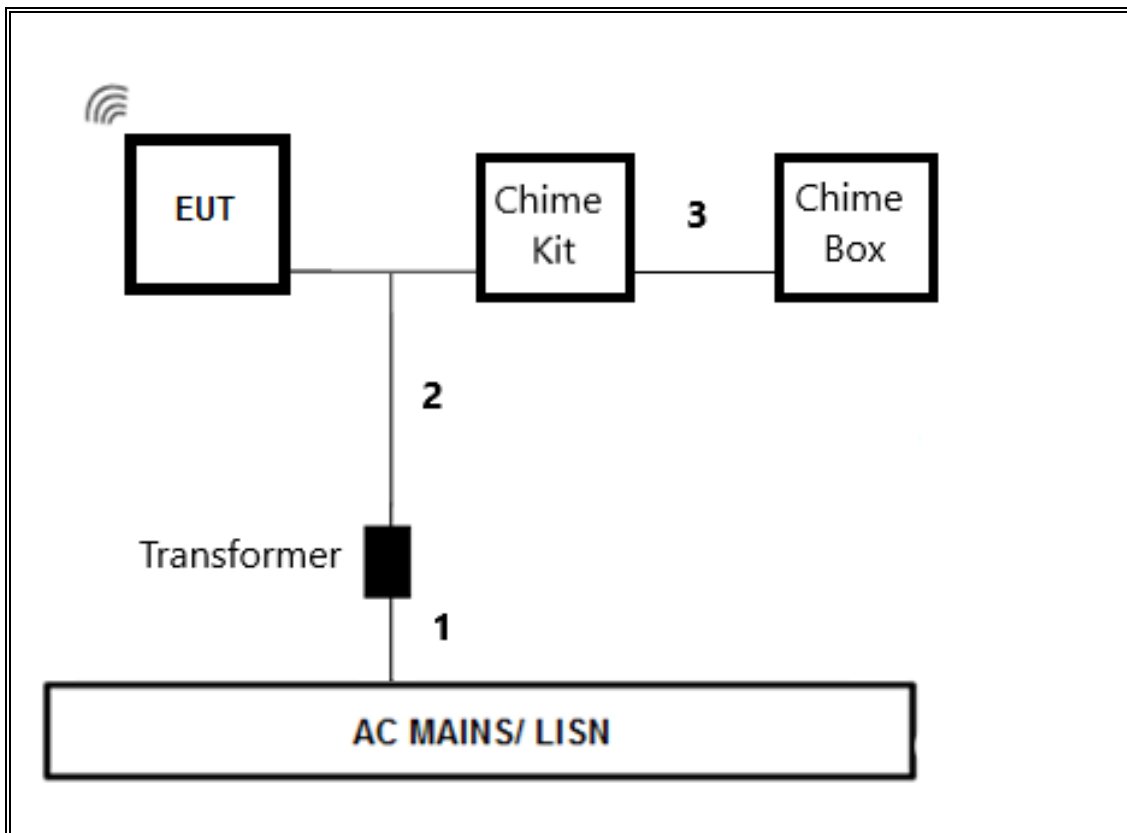

---

## 7. MEASUREMENT METHOD

On Time and Duty Cycle: KDB 789033 D02 v02r01, Section B.

6 dB Emission BW: KDB 789033 D02 v02r01, Section C.2

26 dB Emission BW: KDB 789033 D02 v02r01, Section C.1

99% Occupied BW: KDB 789033 D02 v02r01, Section D.

Conducted Output Power: KDB 789033 D02 v02r01, Section E.3.b (Method PM-G) and KDB 789033 D02 v02r01, Section E.2.b (Method SA-1)

Power Spectral Density: KDB 789033 D02 v02r01, Section F

Unwanted emissions in restricted bands: KDB 789033 D02 v02r01, Sections G.3, G.4, G.5, and G.6.

Unwanted emissions in non-restricted bands: KDB 789033 D02 v02r01, Sections G.3, G.4, and G.5.

AC Power Line Conducted Emissions: ANSI C63.10-2013, Section 6.2.

Radiated Spurious Emissions Below 30MHz: ANSI C63.10-2013 Section 6.4

## 8. TEST AND MEASUREMENT EQUIPMENT

The following test and measurement equipment was utilized for the tests documented in this report:

TEST EQUIPMENT LIST				
Description	Manufacturer	Model	Asset	Cal Due
Antenna, Passive Loop 30Hz - 1MHz	ELECTRO METRICS	EM-6871	PRE0179465	07/27/2021
Antenna, Passive Loop 100KHz - 30MHz	ELECTRO METRICS	EM-6872	PRE0179467	07/27/2021
Antenna, Horn 1-18GHz	ETS-Lindgren	3117	T863	08/31/2021
Amplifier, 100MHz-18GHz	AMPLICAL	AMP0.1G18-47-20	PRE0197319	05/04/2021
Antenna, Broadband Hybrid, 30MHz to 3GHz	SunAR rf motion	JB3	PRE0181574	10/14/2020
Amplifier, 9KHz to 1GHz, 32dB	SONOMA INSTRUMENT	310	175953	01/23/2021
EMI TEST RECEIVER	Rohde & Schwarz	ESW44	PRE0179376	04/03/2021
Antenna Horn, 18 to 26GHz	ARA	SWH-28	T448	05/20/2021
Antenna, Horn 26 to 40GHz	ARA	MWH-2640/B	T445	05/20/2021
High Frequency Amplifier Switch Box	Agilent Technology	8449B	PRE0183142	04/08/2021
Power Meter, P-series single channel	Keysight Technologies Inc	N1911A	T1268	01/22/2021
Power Sensor, P-series, 50MHz to 18GHz, Wideband	Keysight Technologies Inc	N1921A	T413	02/26/2021
AC Line Conducted				
Description	Manufacturer	Model	ID Num	Cal Due
LISN	Fischer Custom Communications, Inc	FCC-LISN-50/250-25-2-01-480V	PRE0186446	01/21/2021
L.I.S.N	FCC INC.	FCC LISN 50/250	24	01/21/2021
EMI TEST RECEIVER	Rohde & Schwarz	ESR	T1436	02/20/2021
Transient Limiter	COM-POWER	LIT-930A	PRE0129246	01/23/2021
UL AUTOMATION SOFTWARE				
Radiated Software	UL	UL EMC	Rev 9.5, 30 Apr, 2020	
Antenna Port Software	UL	UL RF	AP2020.9.1	
AC Line Conducted Software	UL	UL EMC	Rev 9.5, 07 Jul 2020	

## 9. ANTENNA PORT TEST RESULTS

### 9.1. ON TIME AND DUTY CYCLE

#### LIMITS

None; for reporting purposes only.

#### PROCEDURE

KDB 789033 Zero-Span Spectrum Analyzer Method.

#### ON TIME AND DUTY CYCLE RESULTS

Mode	ON Time B (msec)	Period (msec)	Duty Cycle x (linear)	Duty Cycle (%)	Duty Cycle Correction Factor (dB)	1/B Minimum VBW (kHz)
802.11n HT20	1.92	2.02	0.950	95.05%	0.22	0.521
802.11n HT40	0.94	1.04	0.904	90.38%	0.44	1.064
802.11ac VHT80	0.46	0.56	0.821	82.14%	0.85	2.174

**DUTY CYCLE PLOTS**

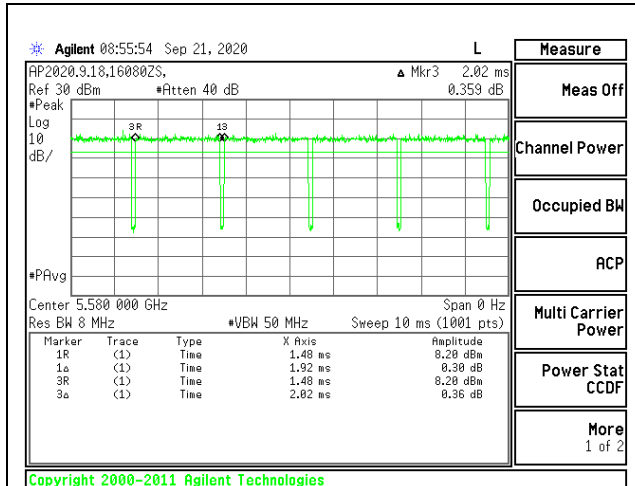

**DUTY CYCLE 802.11n HT20 MODE**

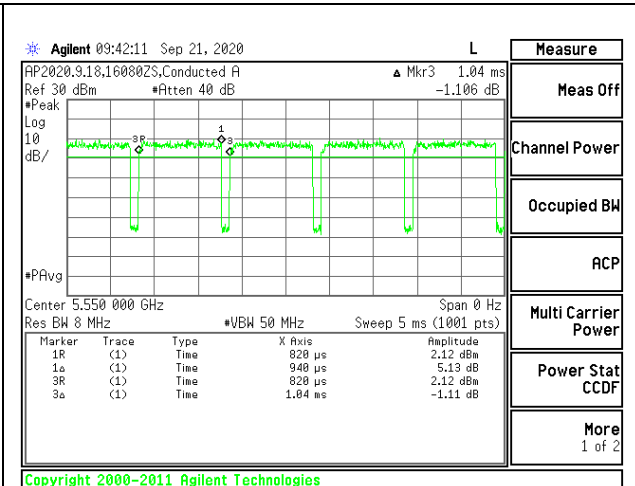

**DUTY CYCLE 802.11n HT40 MODE**

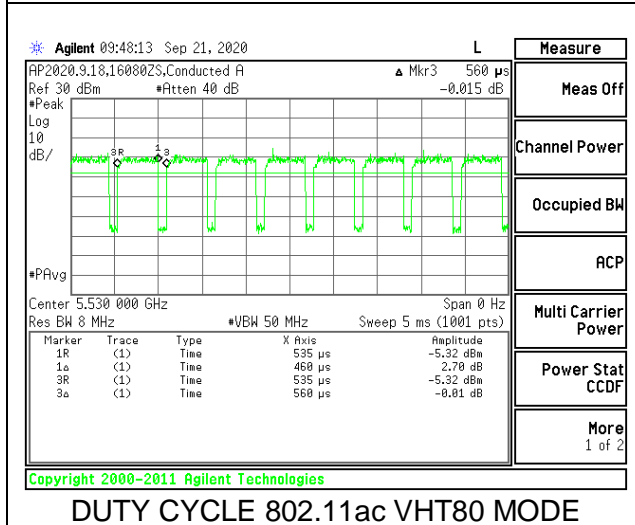

**DUTY CYCLE 802.11ac VHT80 MODE**

## 9.2. 26 dB BANDWIDTH

### LIMITS

None; for reporting purposes only.

### RESULTS

#### 9.2.1. 802.11n HT20 MODE IN THE 5.2 GHz BAND

##### 2TX Antenna 1 + Antenna 2 CDD MODE

Channel	Frequency (MHz)	26 dB Bandwidth Antenna 1 (MHz)	26 dB Bandwidth Antenna 2 (MHz)
Low	5180	22.40	22.10
Mid	5200	22.35	22.05
High	5240	19.50	19.25

### LOW CHANNEL

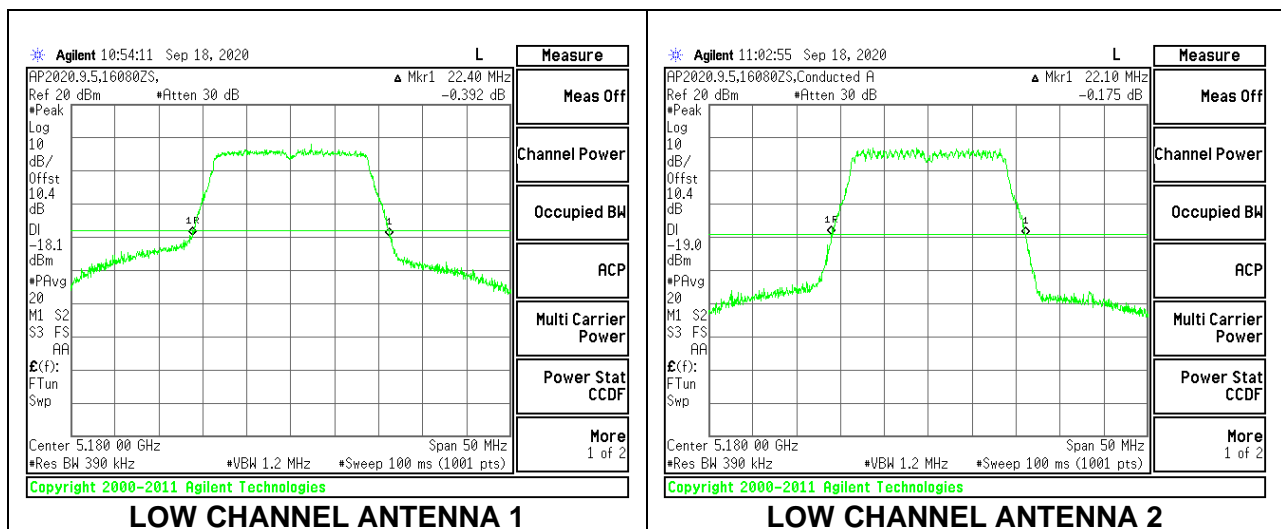

### MID CHANNEL

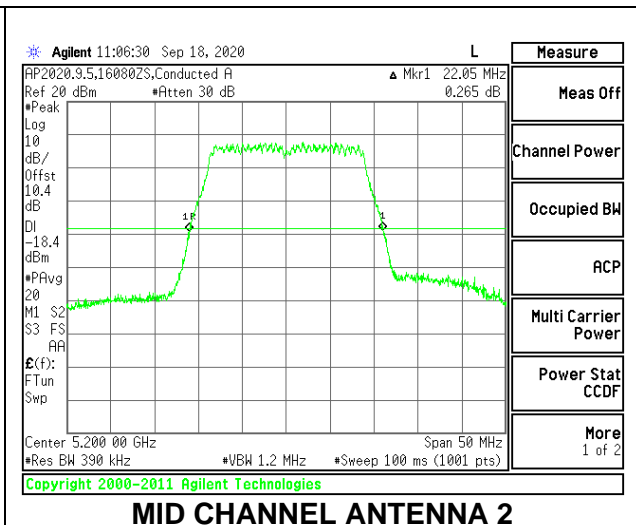
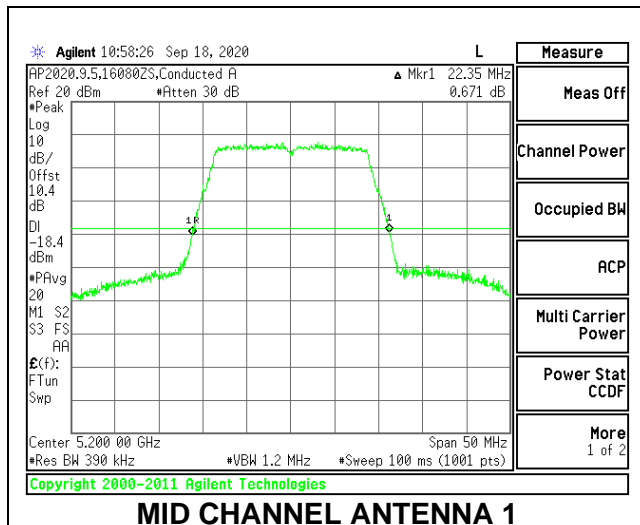

### HIGH CHANNEL

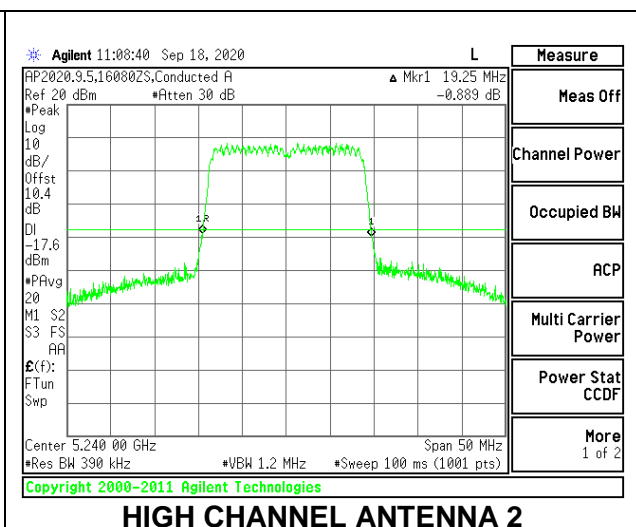
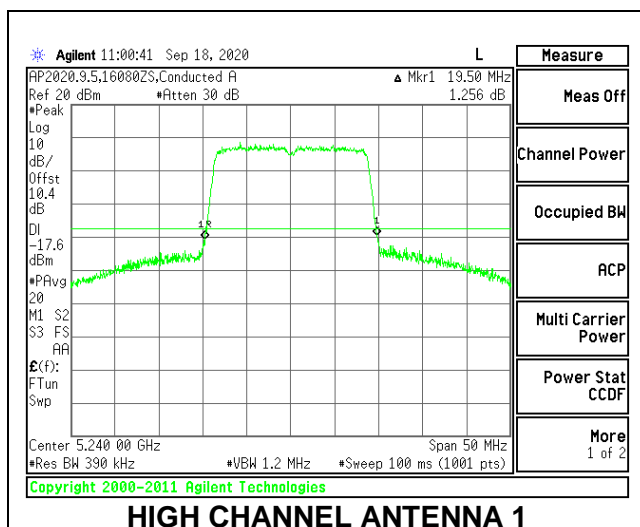



### 9.2.2. 802.11n HT40 MODE IN THE 5.2 GHz BAND

#### 2TX Antenna 1 + Antenna 2 CDD MODE

Channel	Frequency (MHz)	26 dB Bandwidth Antenna 1 (MHz)	26 dB Bandwidth Antenna 2 (MHz)
Low	5190	41.30	40.70
High	5230	41.20	41.00

#### LOW CHANNEL

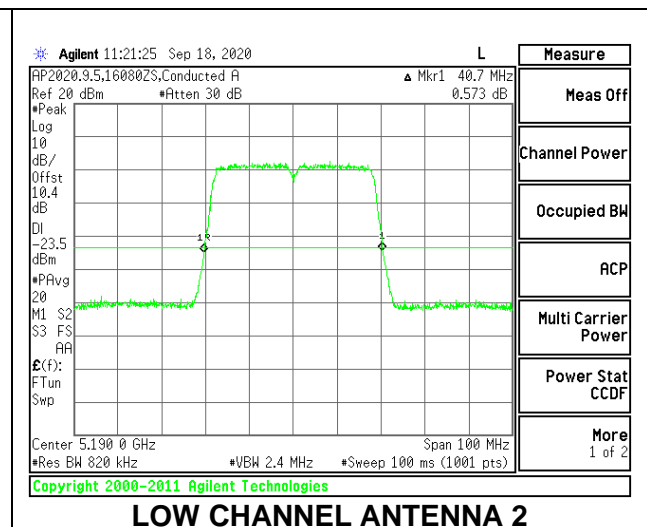
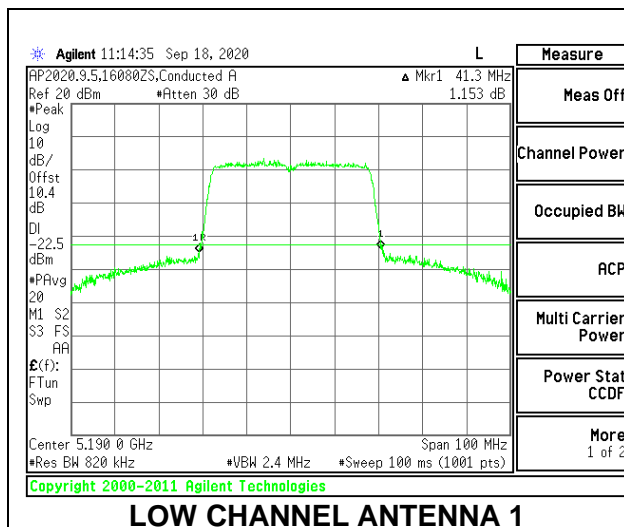

#### HIGH CHANNEL

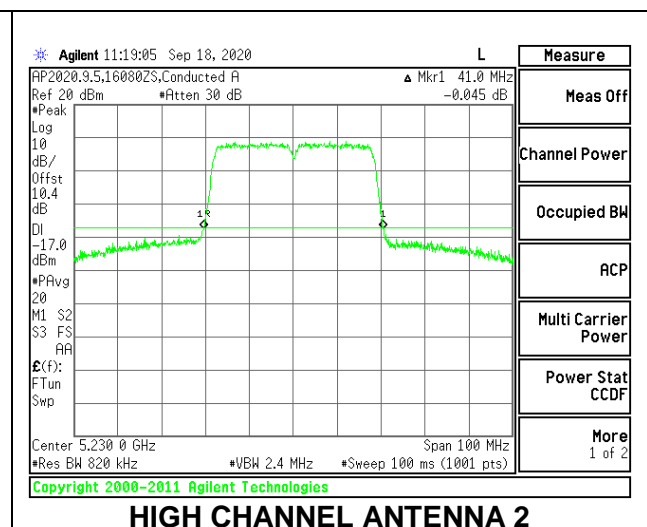
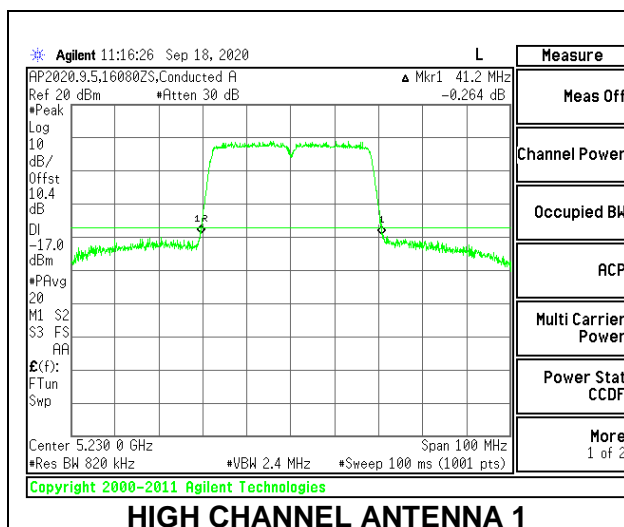

### 9.2.3. 802.11ac VHT80 MODE IN THE 5.2 GHz BAND

#### 2TX Antenna 1 + Antenna 2 CDD MODE

Channel	Frequency (MHz)	26 dB Bandwidth Antenna 1 (MHz)	26 dB Bandwidth Antenna 2 (MHz)
Mid	5210	83.80	83.60

#### MID CHANNEL

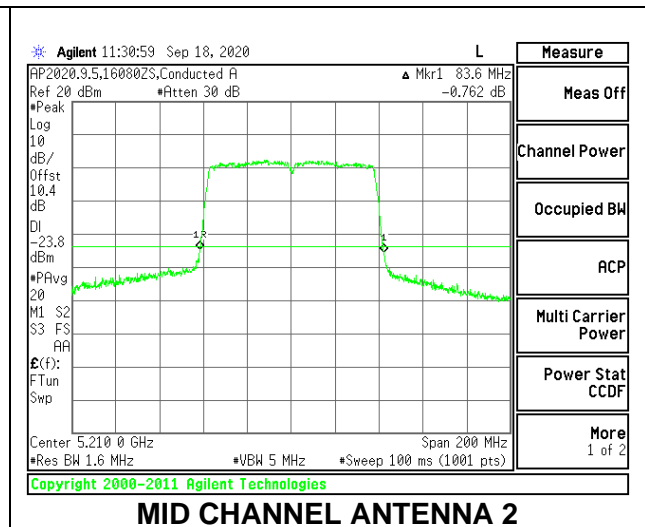
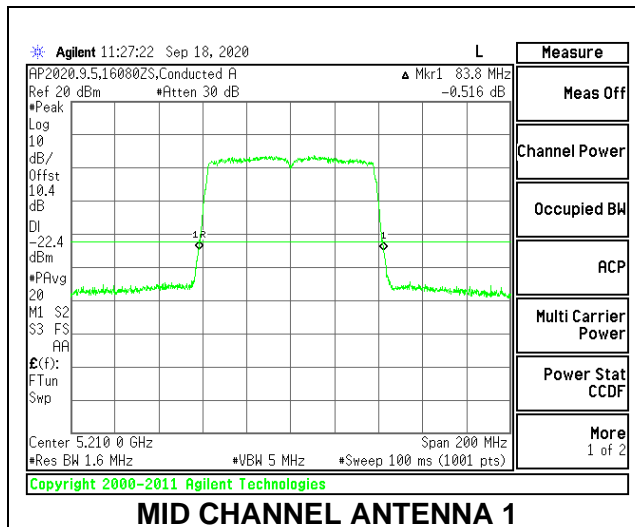

### 9.2.4. 802.11n HT20 MODE IN THE 5.3 GHz BAND

#### 2TX Antenna 1 + Antenna 2 CDD MODE

Channel	Frequency (MHz)	26 dB Bandwidth Antenna 1 (MHz)	26 dB Bandwidth Antenna 2 (MHz)
Low	5260	21.00	19.35
Mid	5300	22.75	21.95
High	5320	22.25	22.00

#### LOW CHANNEL

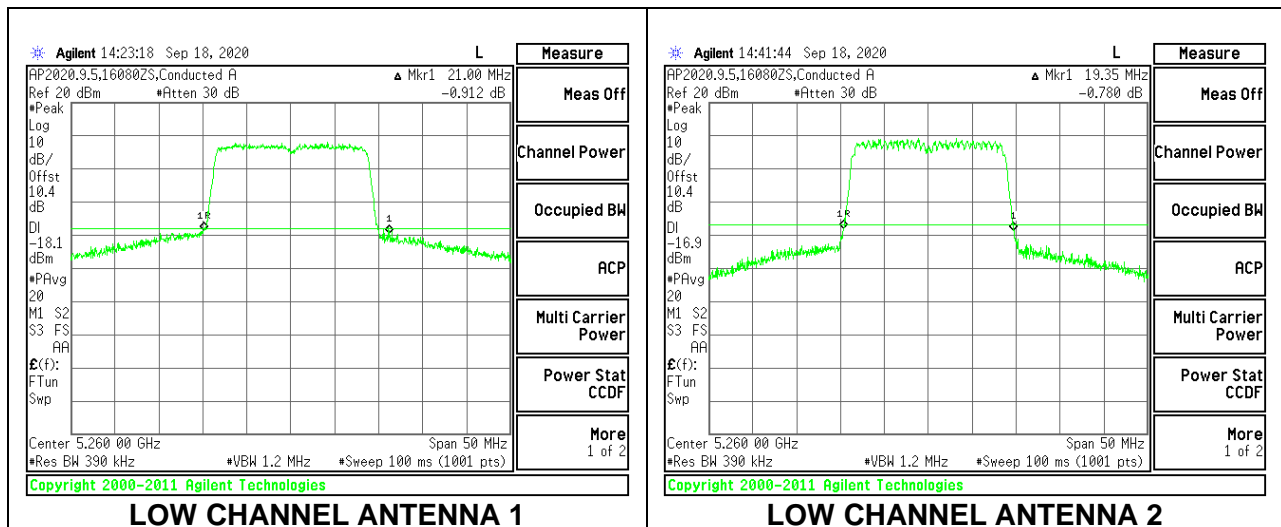

#### MID CHANNEL

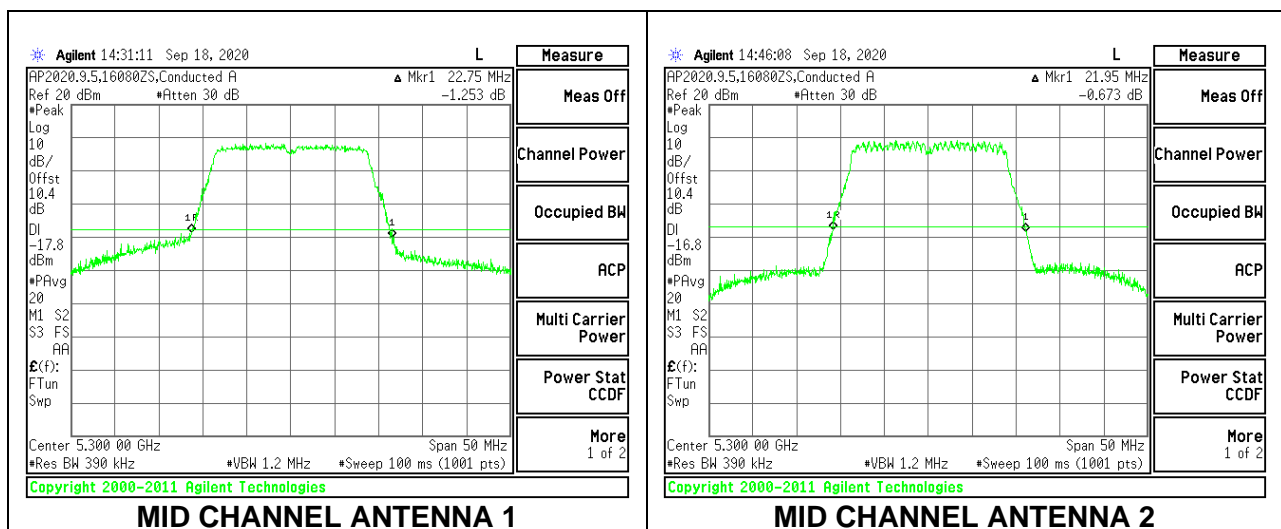

### HIGH CHANNEL

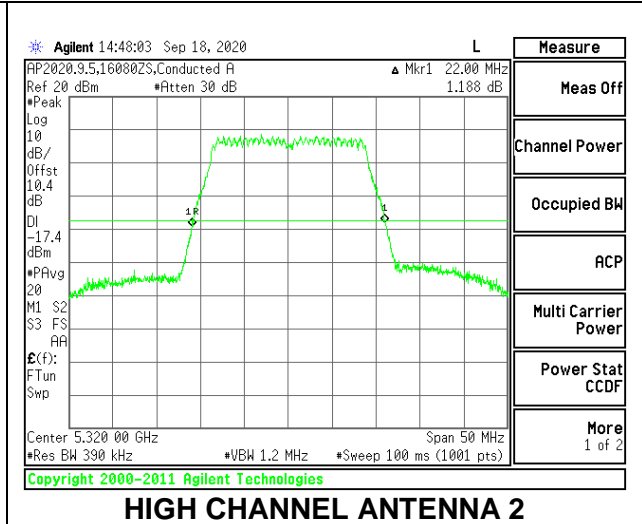
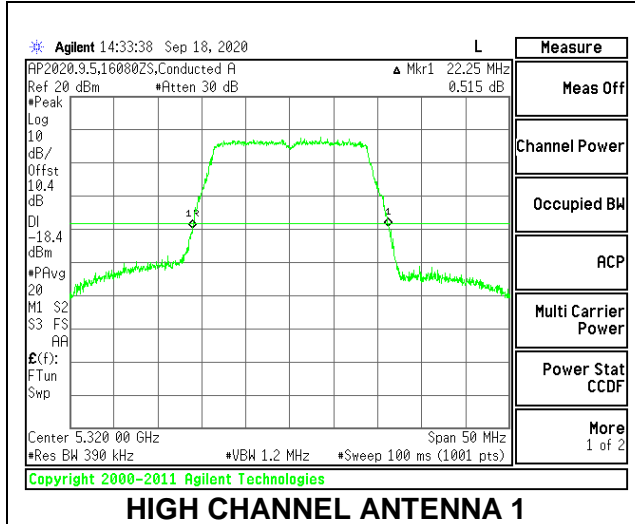

### 9.2.5. 802.11n HT40 MODE IN THE 5.3 GHz BAND

#### 2TX Antenna 1 + Antenna 2 CDD MODE

Channel	Frequency (MHz)	26 dB Bandwidth Antenna 1 (MHz)	26 dB Bandwidth Antenna 2 (MHz)
Low	5270	41.20	40.70
High	5310	41.00	40.70

#### LOW CHANNEL

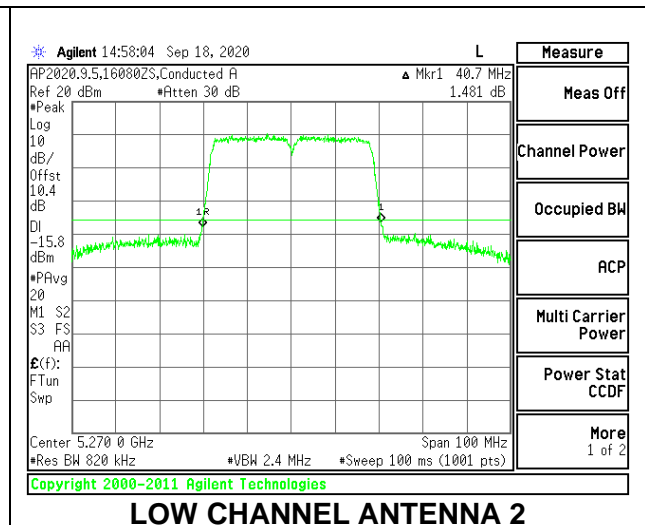
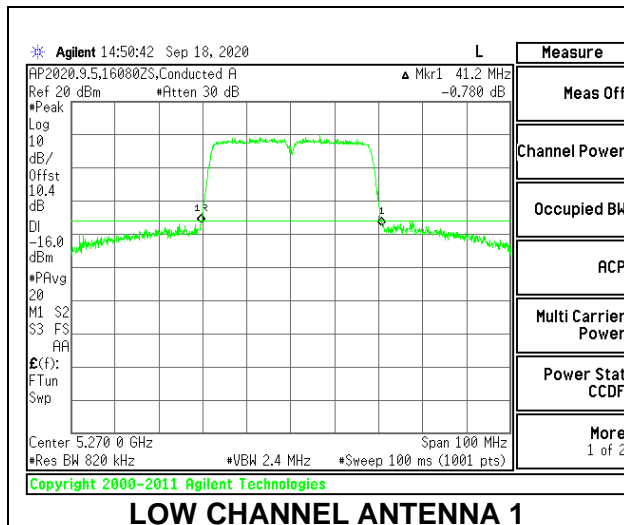

#### HIGH CHANNEL

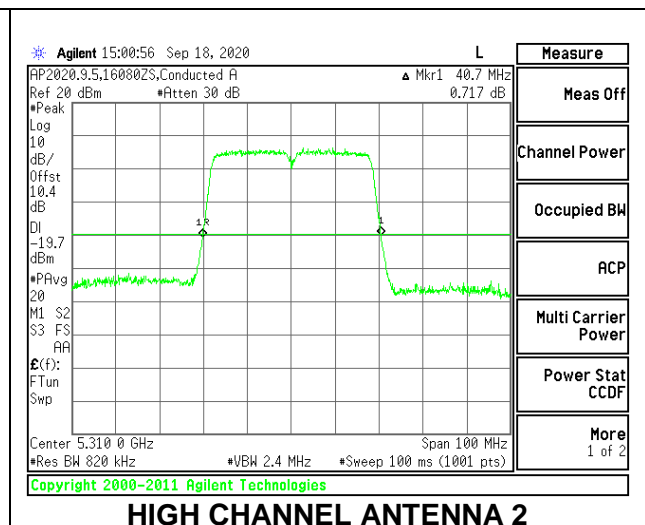
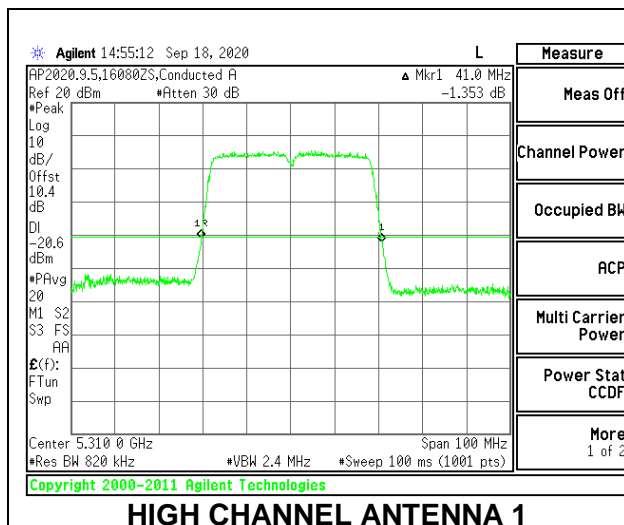

### 9.2.6. 802.11ac VHT80 MODE IN THE 5.3 GHz BAND

#### 2TX Antenna 1 + Antenna 2 CDD MODE

Channel	Frequency (MHz)	26 dB Bandwidth Antenna 1 (MHz)	26 dB Bandwidth Antenna 2 (MHz)
Mid	5290	83.80	83.40

#### MID CHANNEL

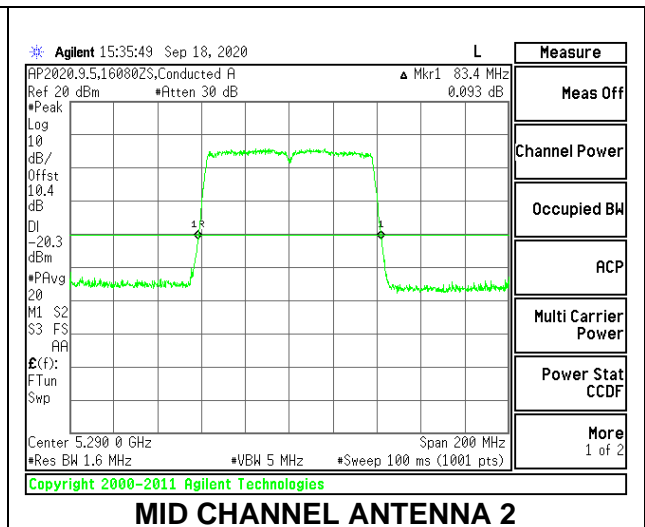
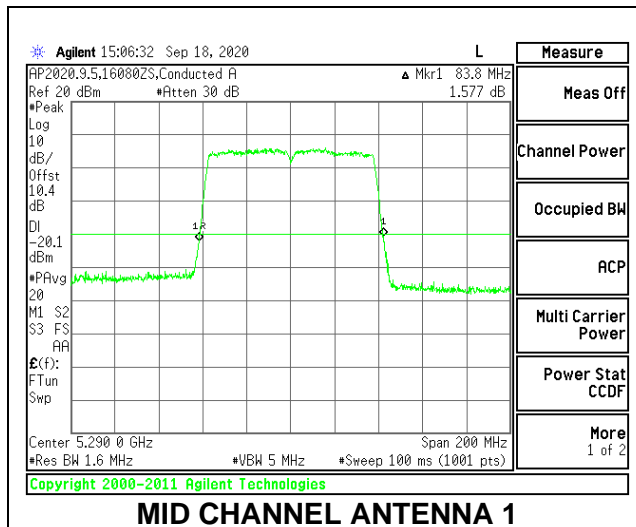

### 9.2.7. 802.11n HT20 MODE IN THE 5.6 GHz BAND

#### 2TX Antenna 1 + Antenna 2 CDD MODE

Channel	Frequency (MHz)	26 dB Bandwidth Antenna 1 (MHz)	26 dB Bandwidth Antenna 2 (MHz)
Low	5500	22.40	22.00
Mid	5580	19.45	19.30
High	5700	22.20	22.05
144	5720	22.25	21.90
144	5720*	16.12	15.95

\*Portion of UNII 2C Band

#### LOW CHANNEL

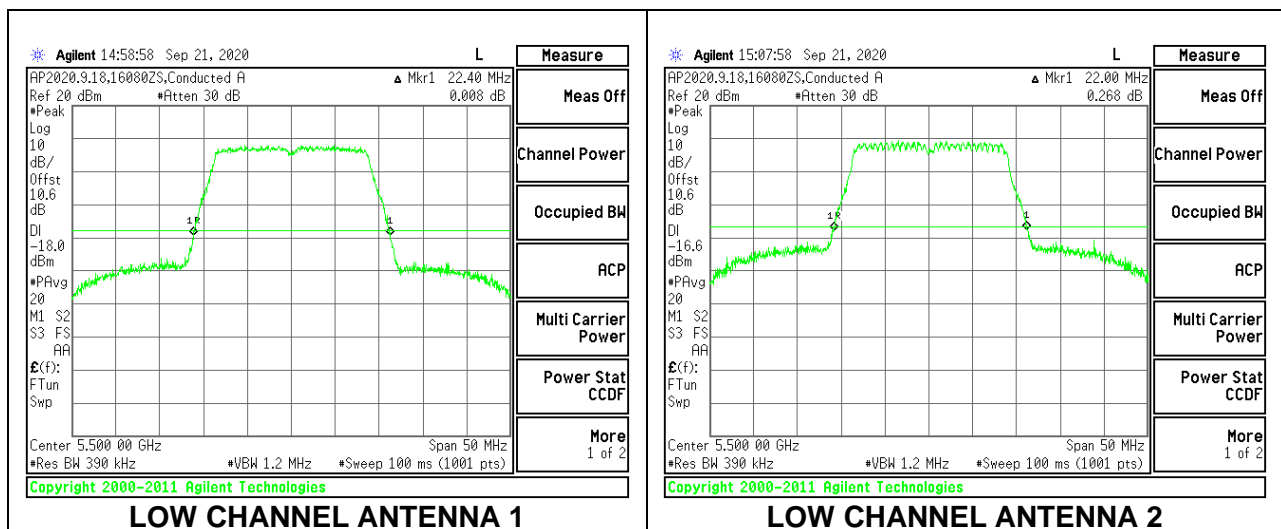

#### MID CHANNEL

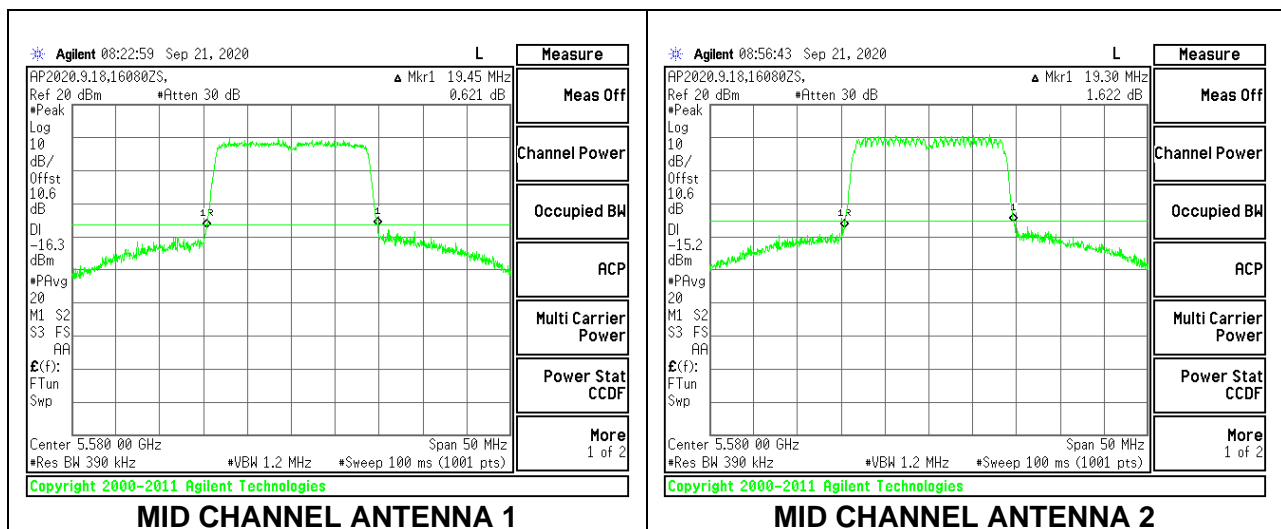

### HIGH CHANNEL

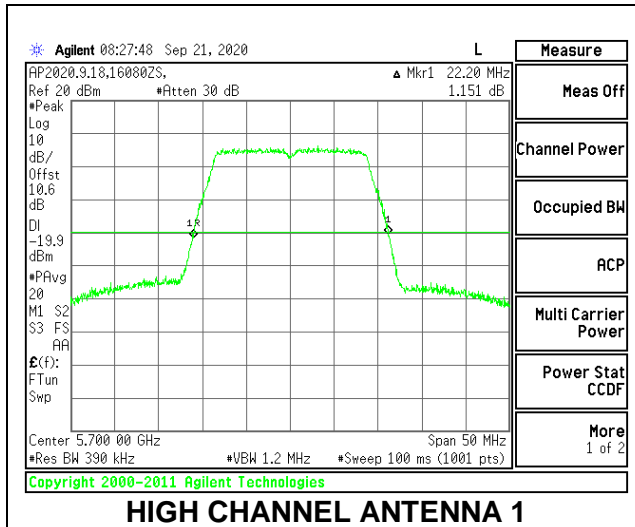

**HIGH CHANNEL ANTENNA 1**

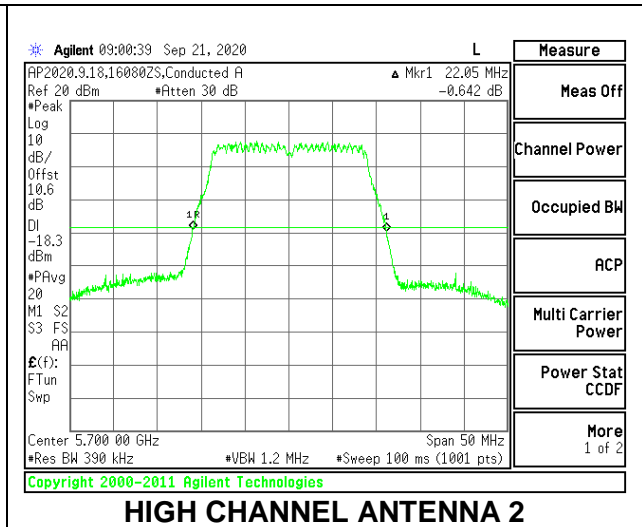

**HIGH CHANNEL ANTENNA 2**

### CHANNEL 144

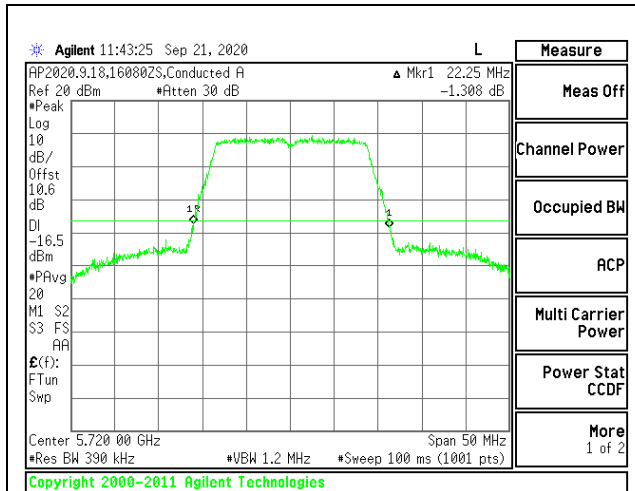

**CHANNEL 144 ANTENNA 1**

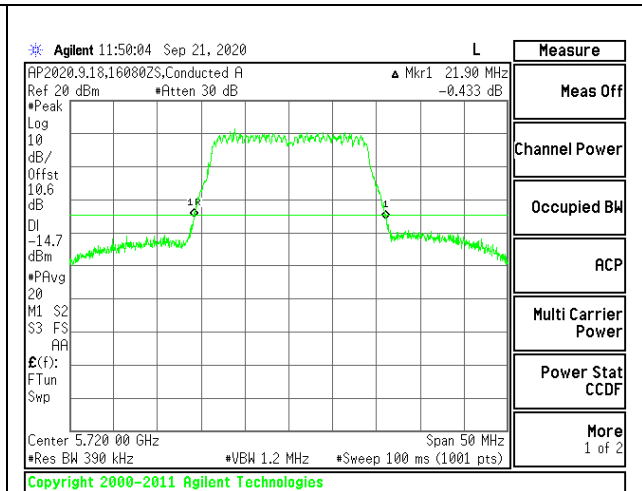

**CHANNEL 144 ANTENNA 2**

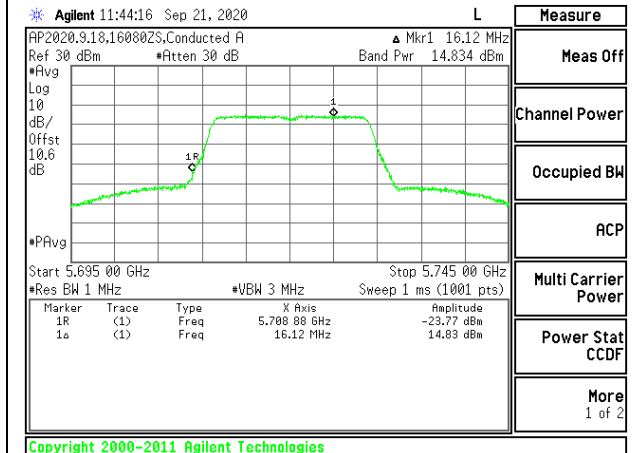

**CHANNEL 144 ANTENNA 1 UNII 2-C**

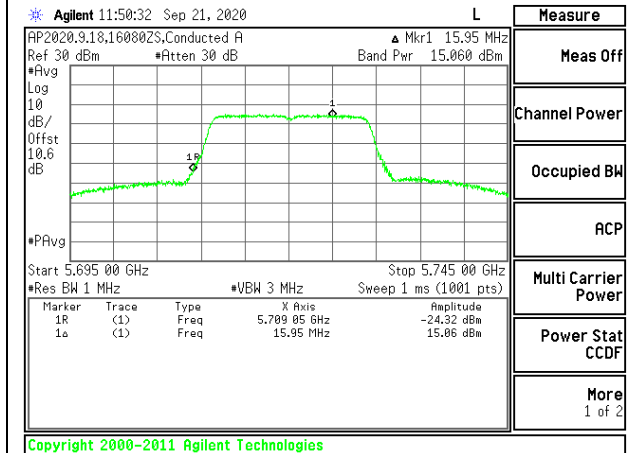

**CHANNEL 144 ANTENNA 2 UNII 2-C**



### 9.2.8. 802.11n HT40 MODE IN THE 5.6 GHz BAND

#### 2TX Antenna 1 + Antenna 2 CDD MODE

Channel	Frequency (MHz)	26 dB Bandwidth Antenna 1 (MHz)	26 dB Bandwidth Antenna 2 (MHz)
Low	5510	41.00	40.70
Mid	5550	41.10	40.90
High	5670	41.30	40.80
142	5710	41.10	40.80
142	5710*	35.55	35.40

\*Portion of UNII 2C Band

#### LOW CHANNEL

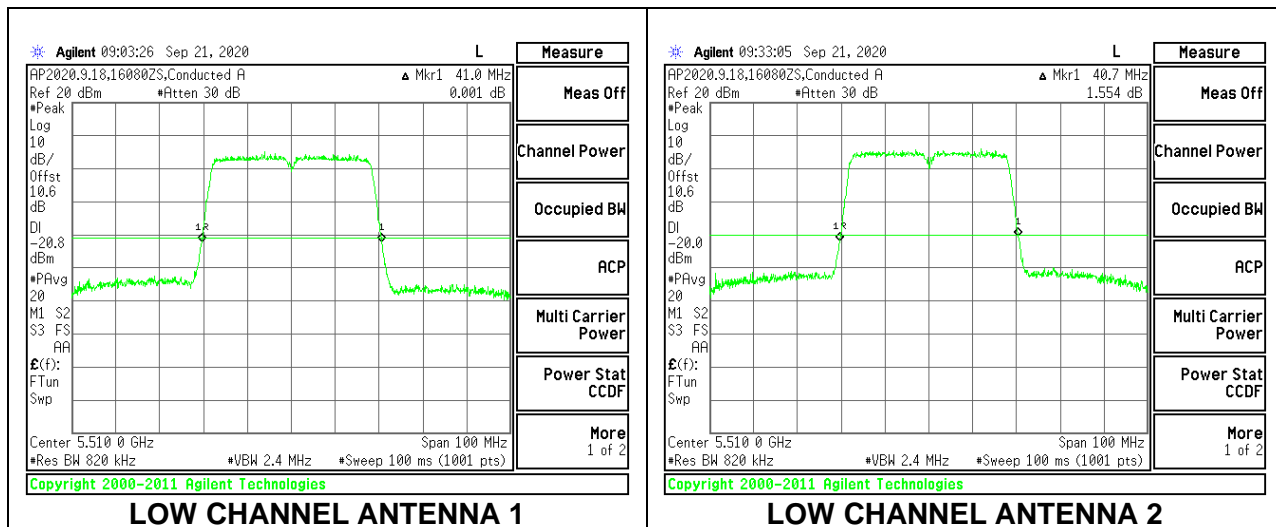

#### MID CHANNEL

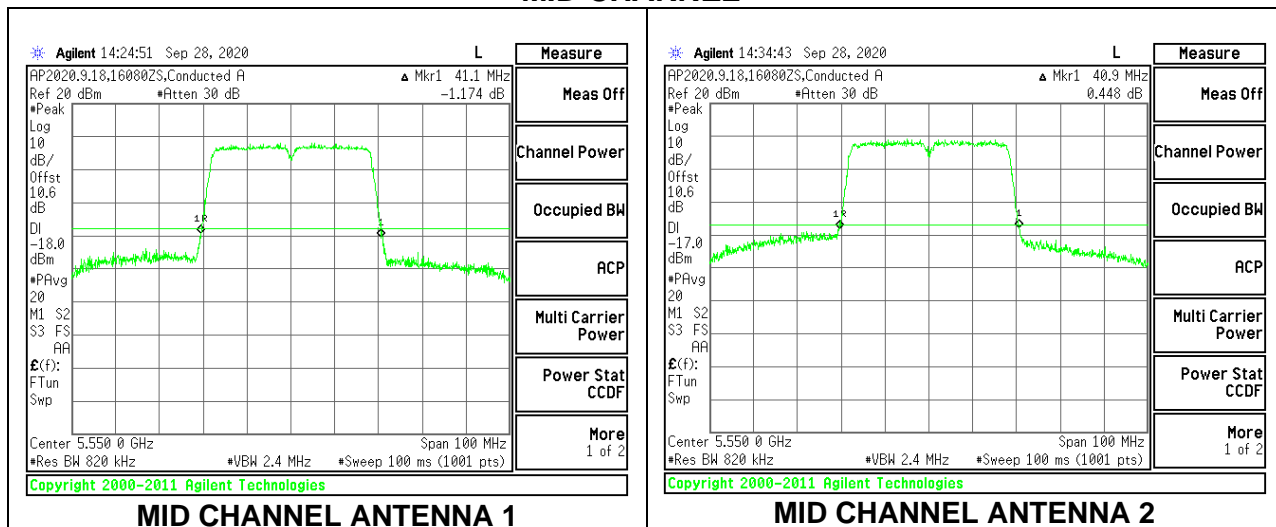

### HIGH CHANNEL

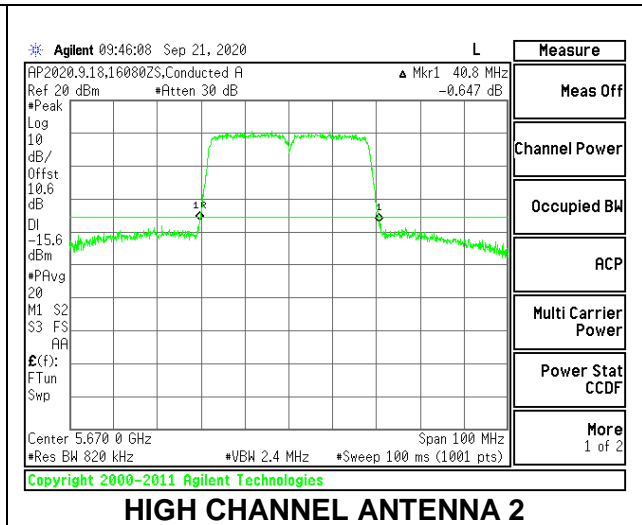
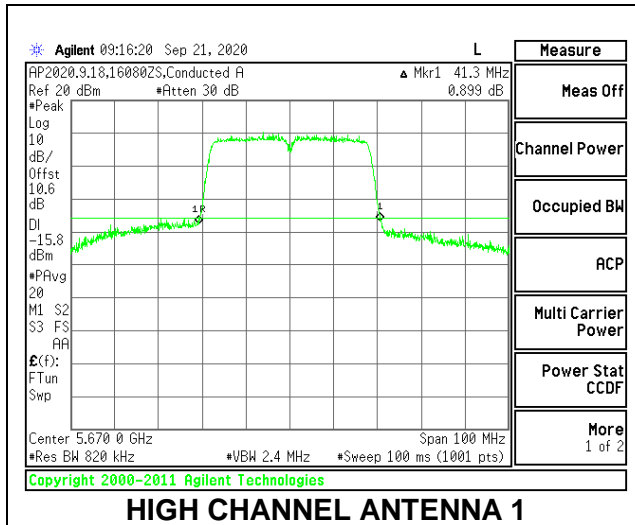

### CHANNEL 142

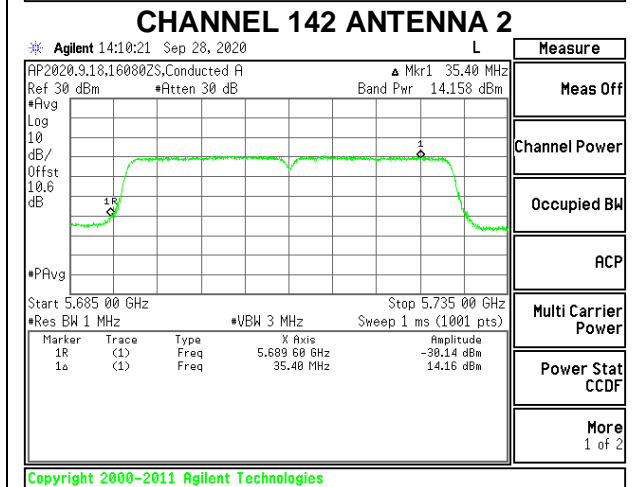
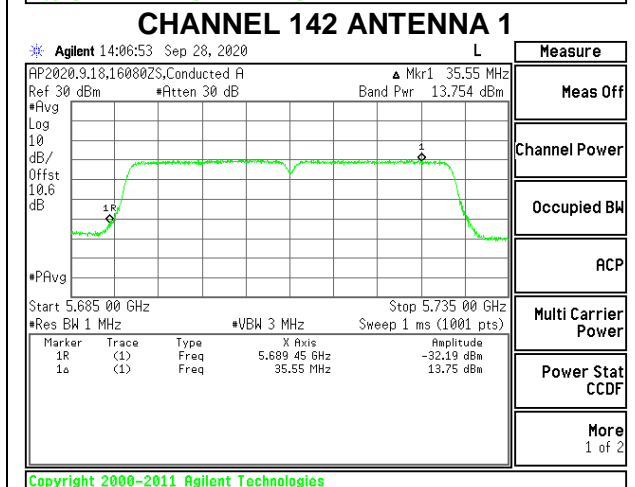
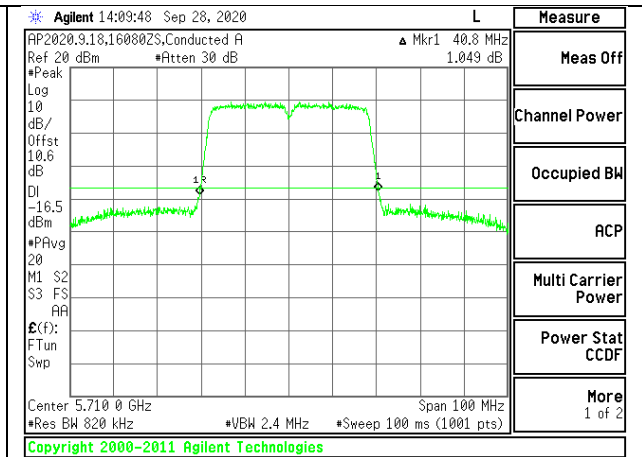
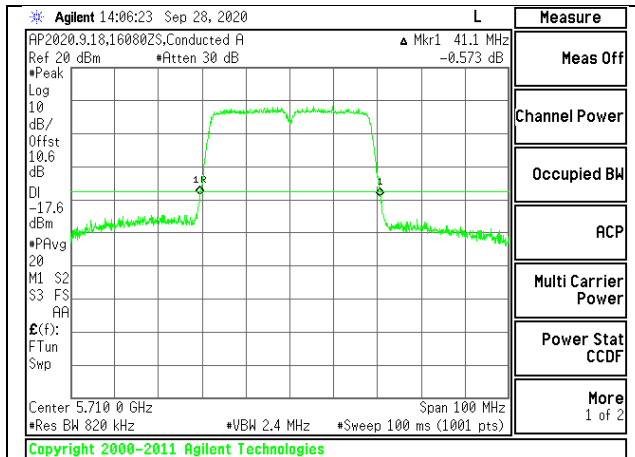

### 9.2.9. 802.11ac VHT80 MODE IN THE 5.6 GHz BAND

#### 2TX Antenna 1 + Antenna 2 CDD MODE

Frequency (MHz)	26 dB Bandwidth Antenna 1 (MHz)	26 dB Bandwidth Antenna 2 (MHz)
5530	83.80	83.40
5610	84.00	84.20
5690	83.80	83.80
5690*	76.90	76.70

\*Portion of UNII 2C Band

#### LOW CHANNEL

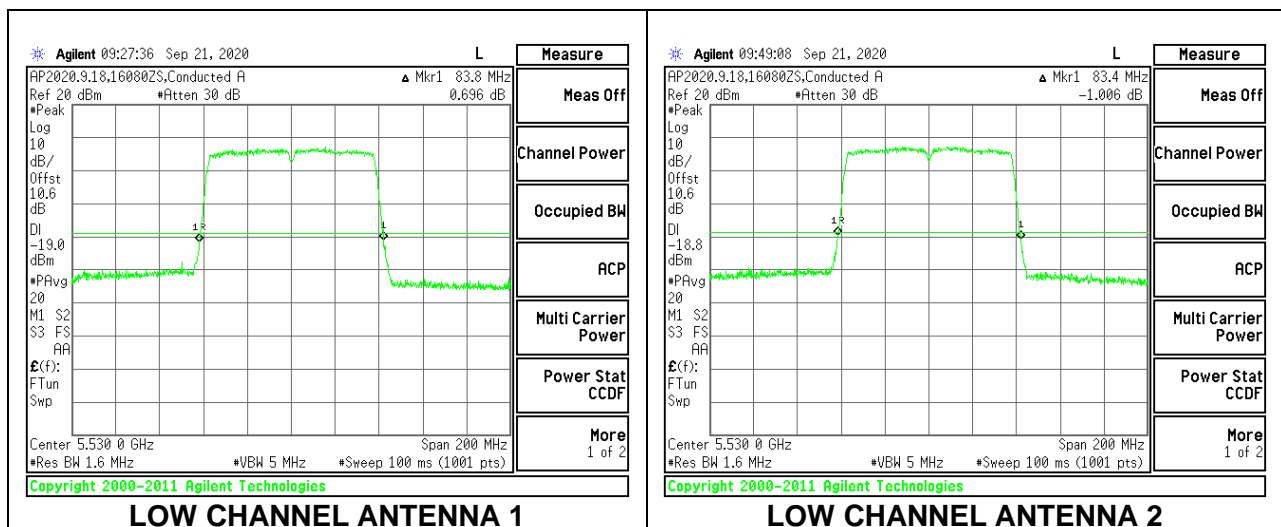

#### HIGH CHANNEL

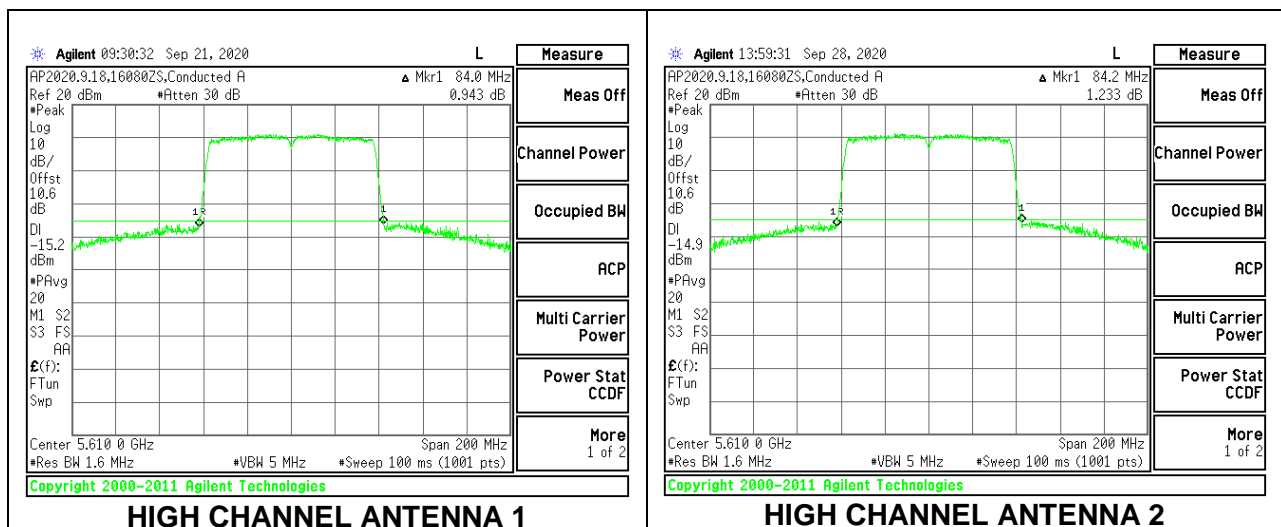

### CHANNEL 138

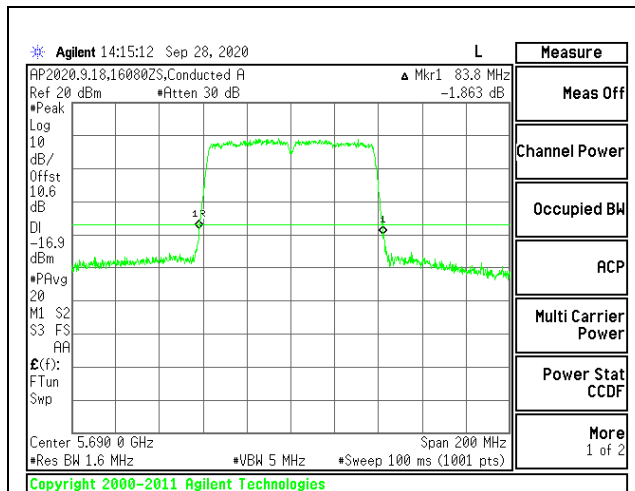

#### CHANNEL 138 ANTENNA 1

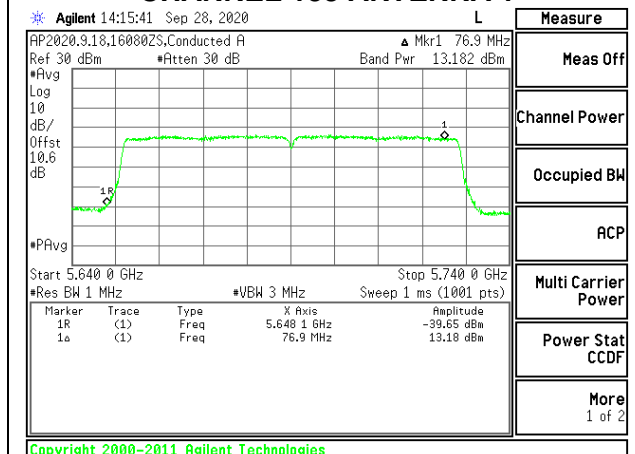

#### CHANNEL 138 ANTENNA 1 UNII 2-C

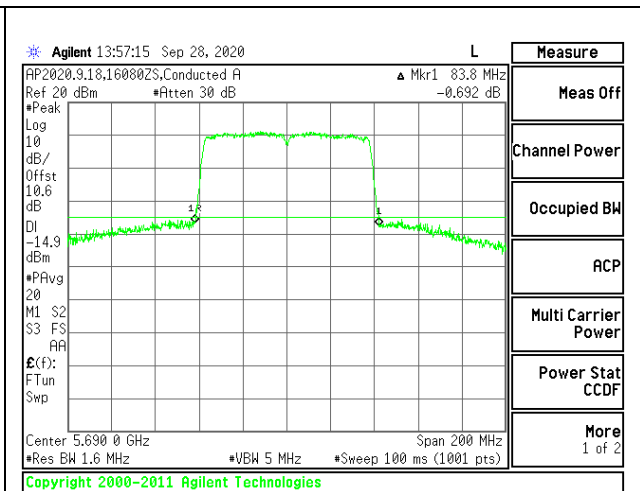

#### CHANNEL 138 ANTENNA 2

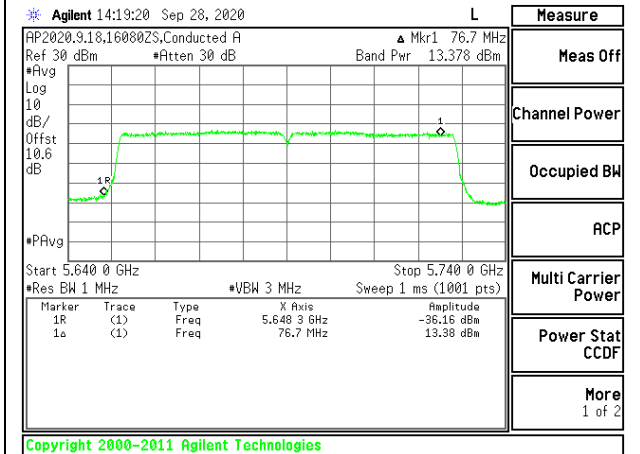

#### CHANNEL 138 ANTENNA 2 UNII 2-C

### 9.2.10. 802.11n HT20 MODE IN THE 5.8 GHz BAND

#### 2TX Antenna 1 + Antenna 2 CDD MODE

Channel	Frequency (MHz)	26 dB Bandwidth Antenna 1 (MHz)	26 dB Bandwidth Antenna 2 (MHz)
Low	5745	22.45	22.00
Mid	5785	22.30	22.20
High	5825	22.85	22.20

#### LOW CHANNEL

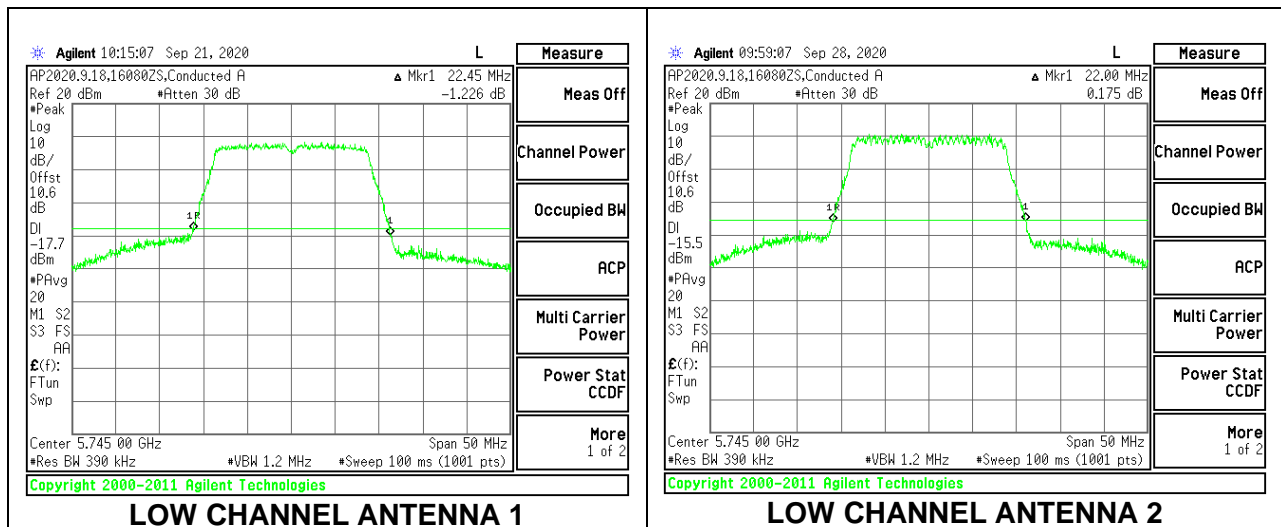

#### MID CHANNEL

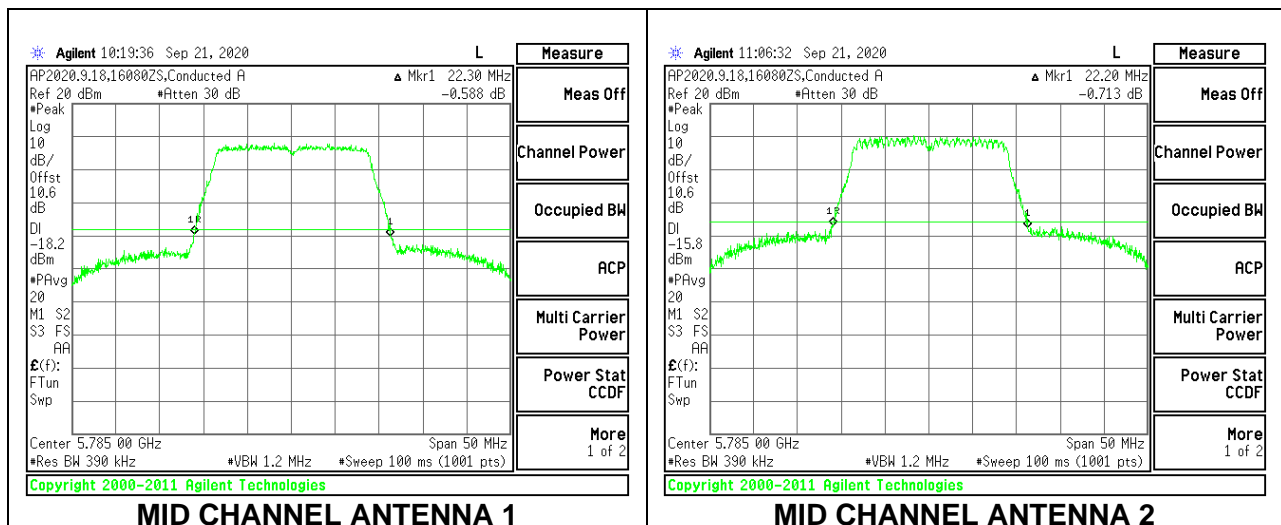

### HIGH CHANNEL

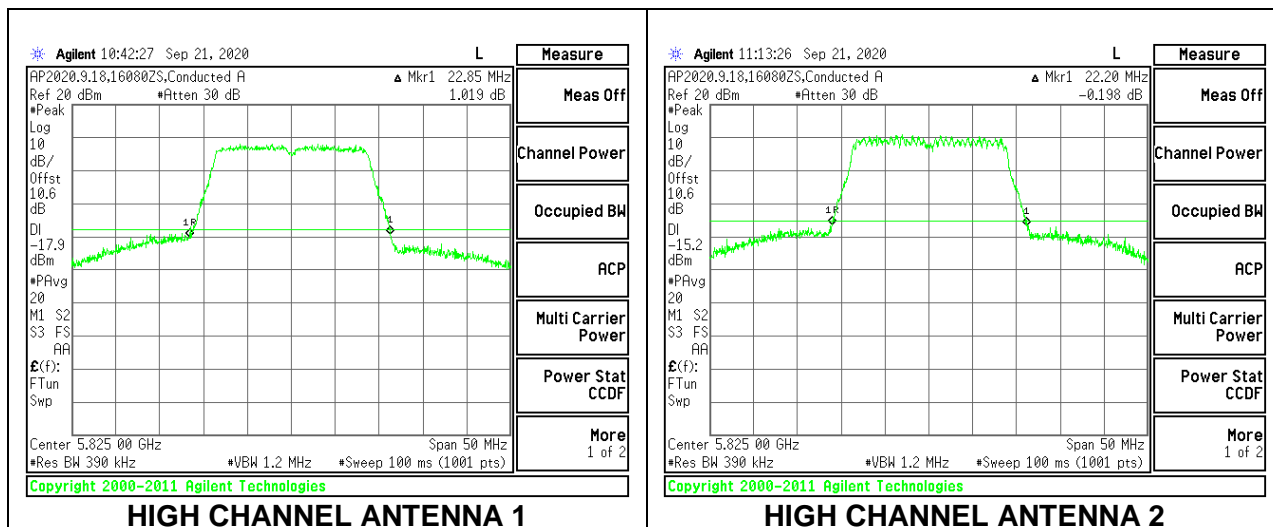

### 9.2.11. 802.11n HT40 MODE IN THE 5.8 GHz BAND

#### 2TX Antenna 1 + Antenna 2 CDD MODE

Channel	Frequency (MHz)	26 dB Bandwidth Antenna 1 (MHz)	26 dB Bandwidth Antenna 2 (MHz)
Low	5755	41.00	40.60
High	5795	41.00	40.60

#### LOW CHANNEL

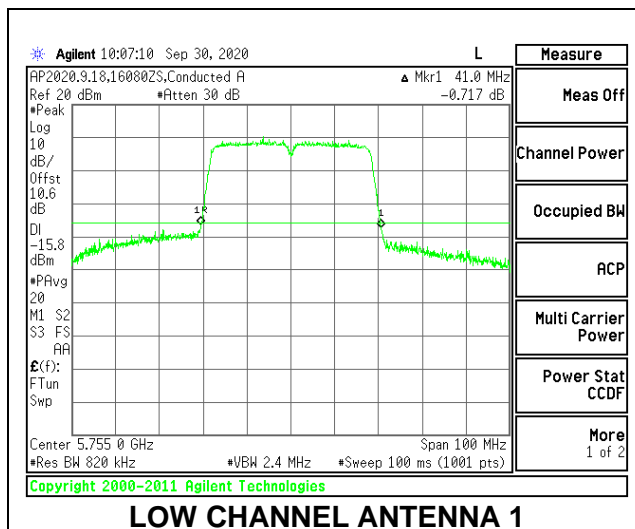

LOW CHANNEL ANTENNA 1

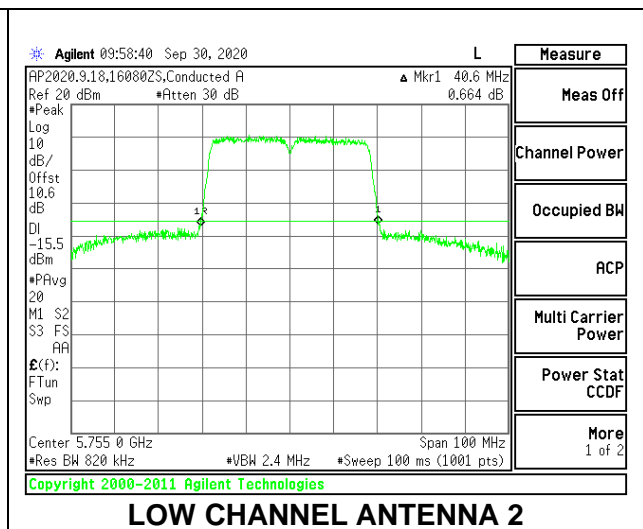

LOW CHANNEL ANTENNA 2

#### HIGH CHANNEL

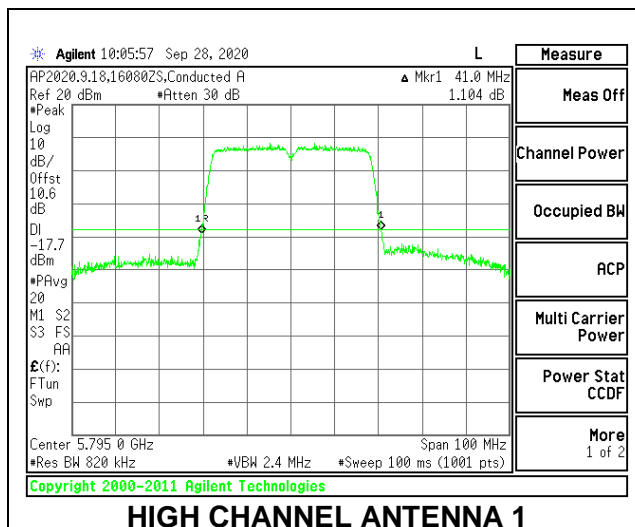

HIGH CHANNEL ANTENNA 1

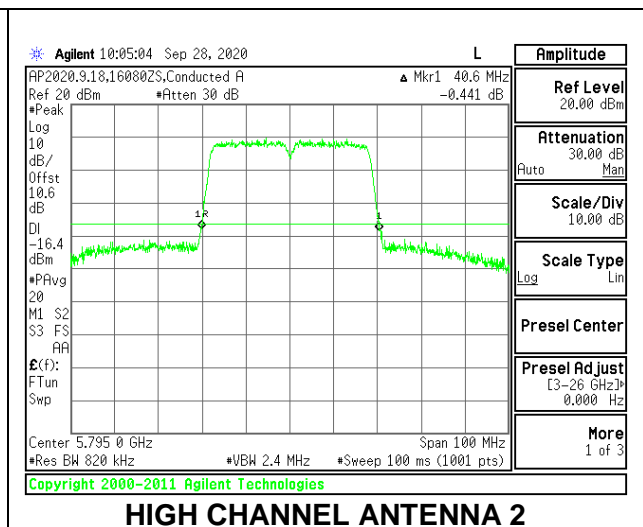

HIGH CHANNEL ANTENNA 2

### 9.2.12. 802.11ac VHT80 MODE IN THE 5.8 GHz BAND

#### 2TX Antenna 1 + Antenna 2 CDD MODE

Channel	Frequency (MHz)	26 dB Bandwidth Antenna 1 (MHz)	26 dB Bandwidth Antenna 2 (MHz)
Mid	5775	84.00	83.40

#### MID CHANNEL

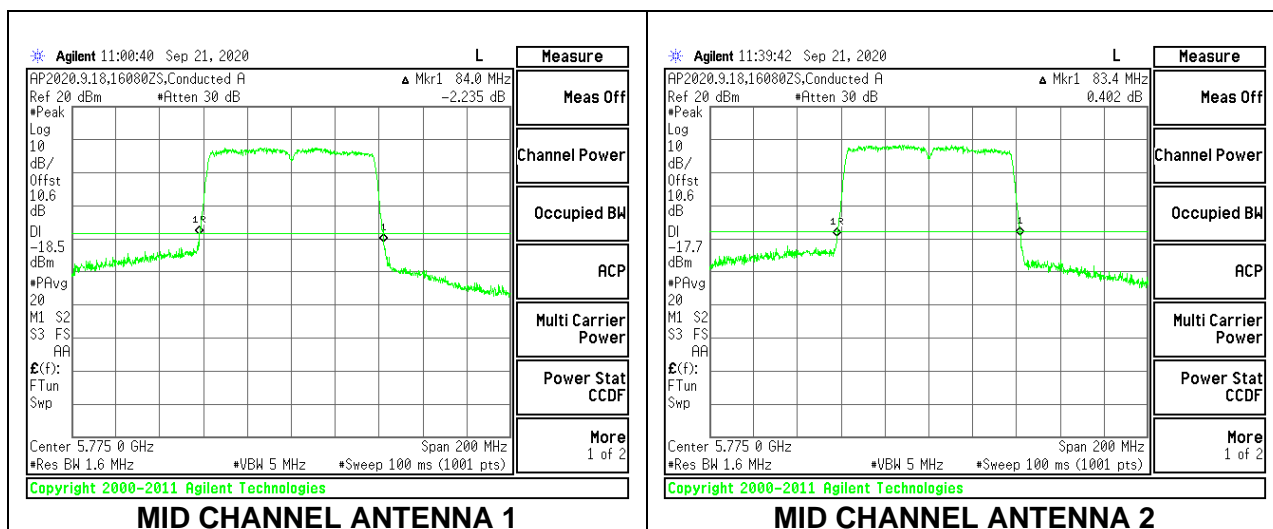



### 9.3. 99% BANDWIDTH

#### LIMITS

None; for reporting purposes only.

#### RESULTS

##### 9.3.1. 802.11n HT20 MODE IN THE 5.2 GHz BAND

##### 2TX Antenna 1 + Antenna 2 CDD MODE

Channel	Frequency (MHz)	99% Bandwidth Antenna 1 (MHz)	99% Bandwidth Antenna 2 (MHz)
Low	5180	17.737	17.853
Mid	5200	17.710	17.948
High	5240	17.437	17.353

#### LOW CHANNEL

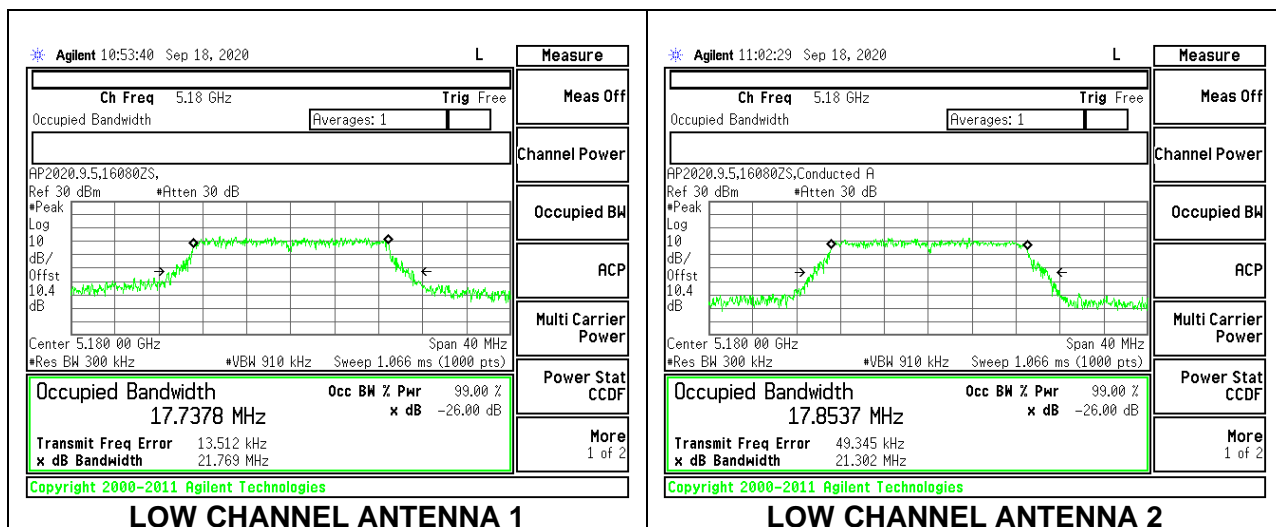

### MID CHANNEL

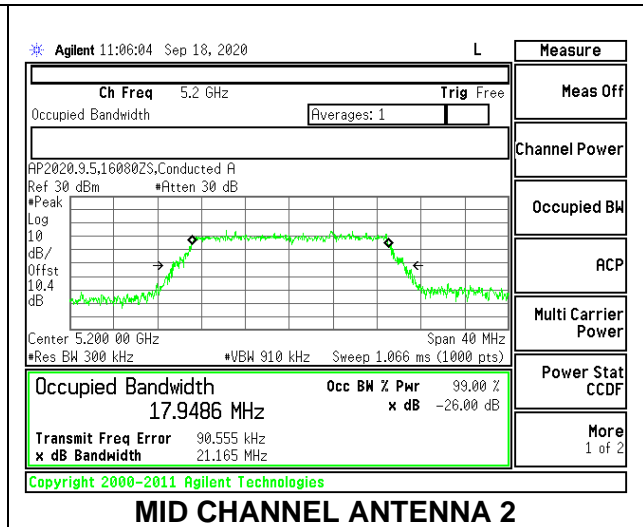
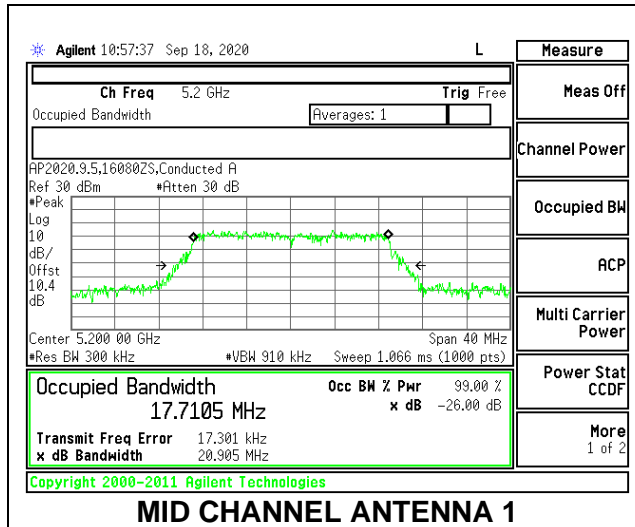

### HIGH CHANNEL

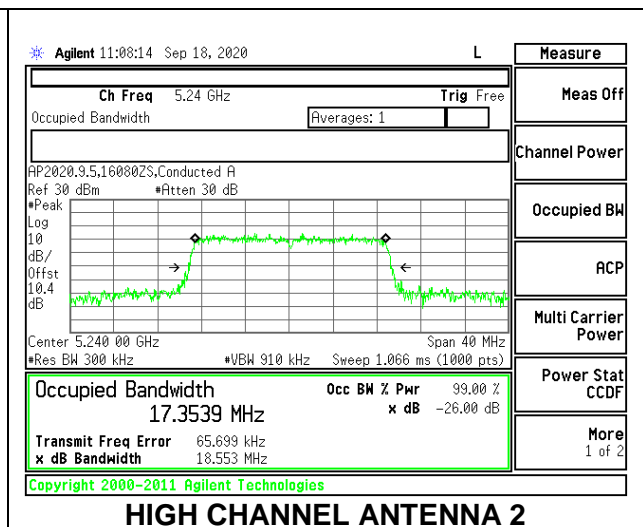
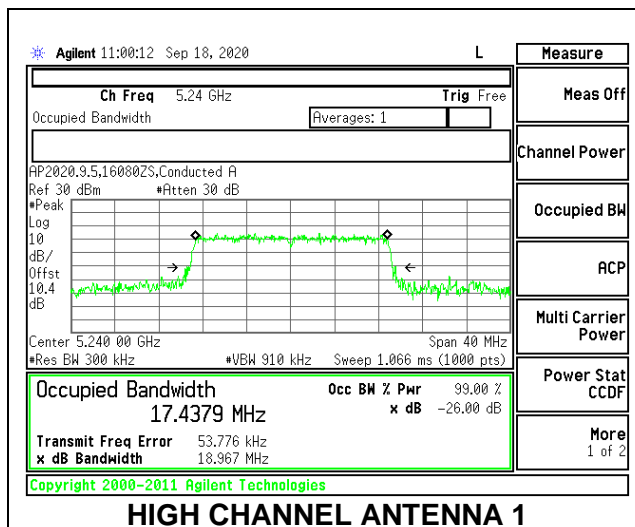

### 9.3.2. 802.11n HT40 MODE IN THE 5.2 GHz BAND

#### 2TX Antenna 1 + Antenna 2 CDD MODE

Channel	Frequency (MHz)	99% Bandwidth Antenna 1 (MHz)	99% Bandwidth Antenna 2 (MHz)
Low	5190	36.233	36.305
High	5230	36.197	36.197

#### LOW CHANNEL

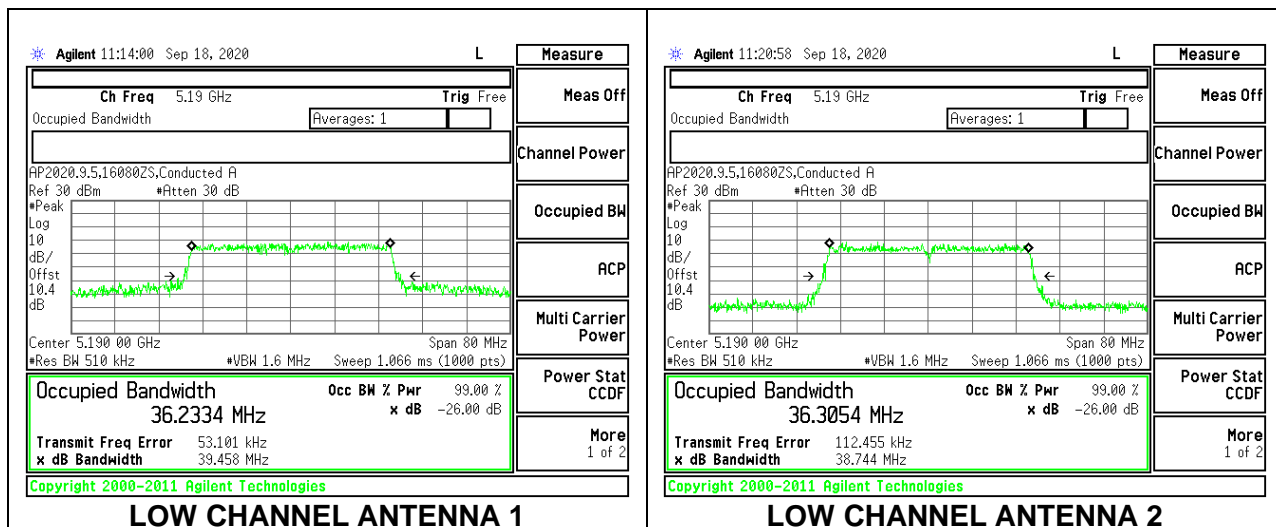

#### HIGH CHANNEL

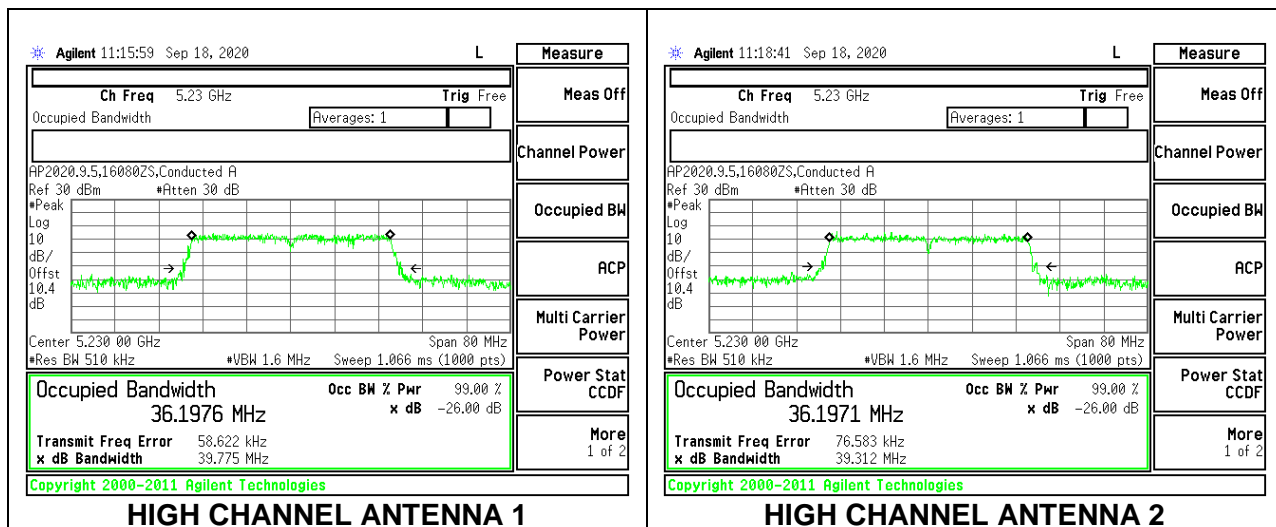

### 9.3.3. 802.11ac VHT80 MODE IN THE 5.2 GHz BAND

#### 2TX Antenna 1 + Antenna 2 CDD MODE

Channel	Frequency (MHz)	99% Bandwidth Antenna 1 (MHz)	99% Bandwidth Antenna 2 (MHz)
Mid	5210	75.789	75.641

#### MID CHANNEL

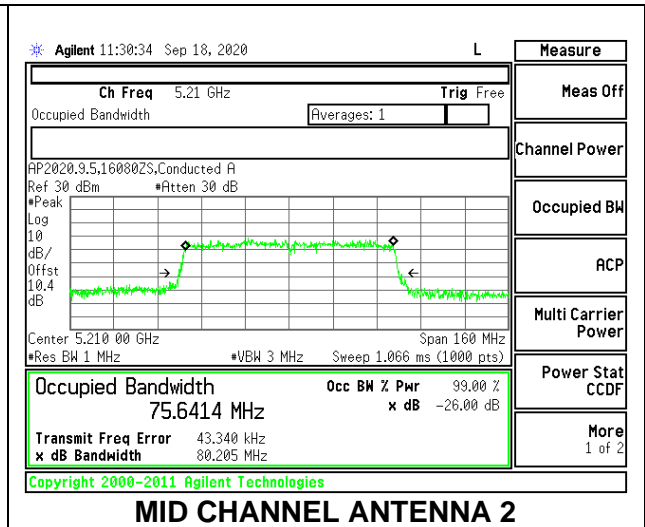
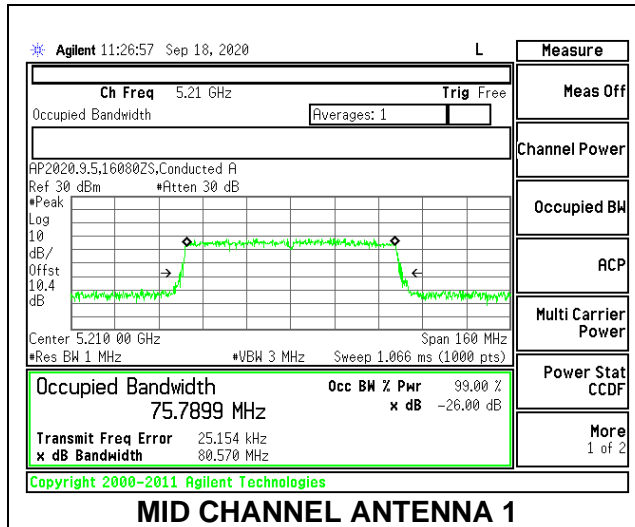

### 9.3.4. 802.11n HT20 MODE IN THE 5.3 GHz BAND

#### 2TX Antenna 1 + Antenna 2 CDD MODE

Channel	Frequency (MHz)	99% Bandwidth Antenna 1 (MHz)	99% Bandwidth Antenna 2 (MHz)
Low	5260	17.510	17.430
Mid	5300	17.956	17.829
High	5320	17.999	17.768

#### LOW CHANNEL

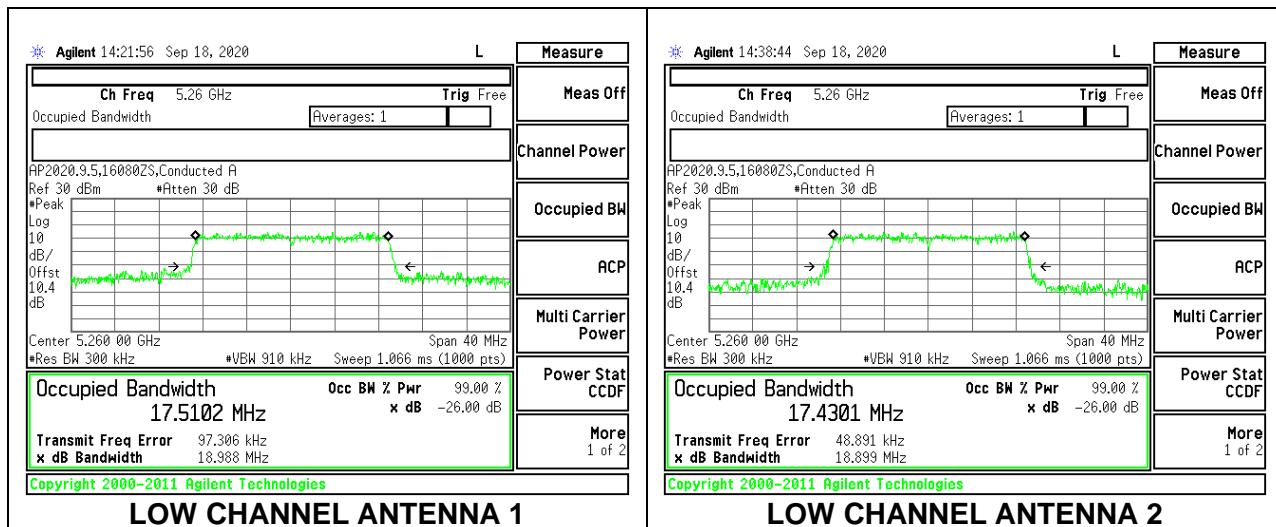

#### MID CHANNEL

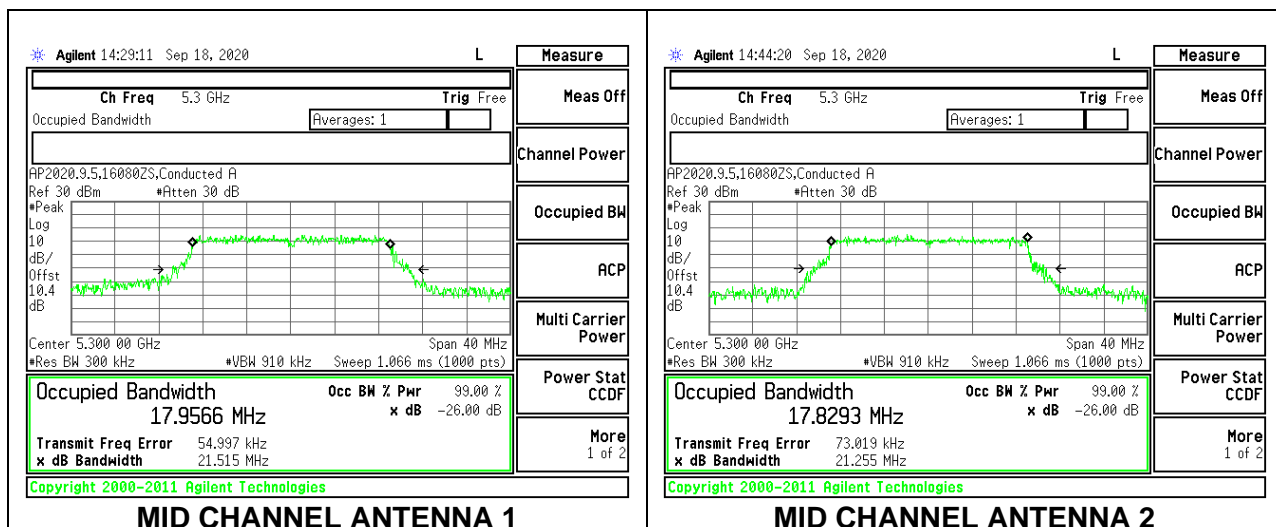

**HIGH CHANNEL**

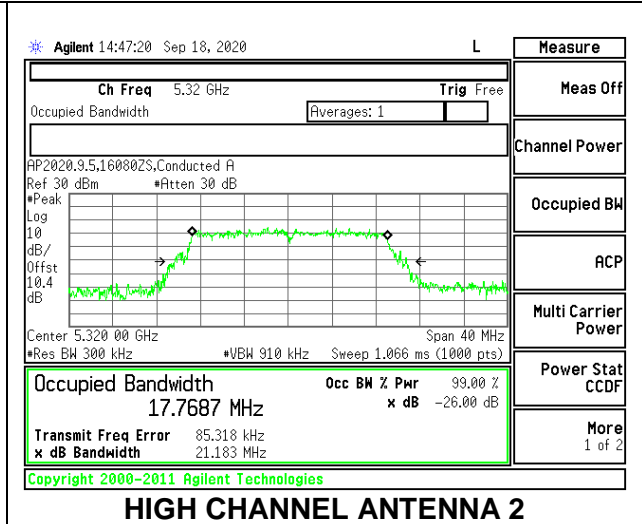
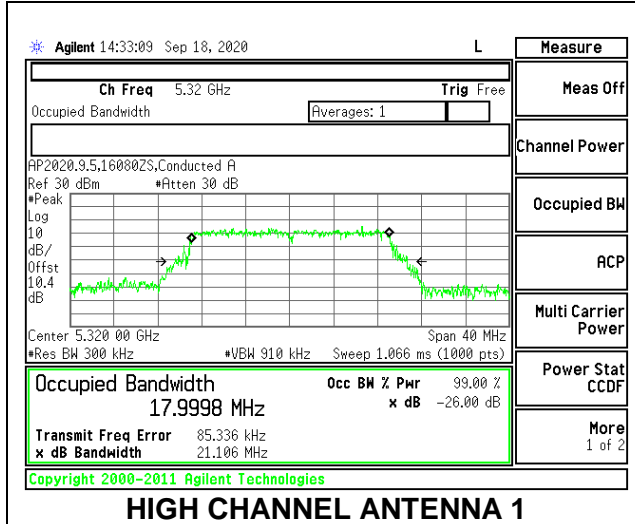

### 9.3.5. 802.11n HT40 MODE IN THE 5.3 GHz BAND

#### 2TX Antenna 1 + Antenna 2 CDD MODE

Channel	Frequency (MHz)	99% Bandwidth Antenna 1 (MHz)	99% Bandwidth Antenna 2 (MHz)
Low	5270	36.246	36.249
High	5310	36.234	36.160

#### LOW CHANNEL

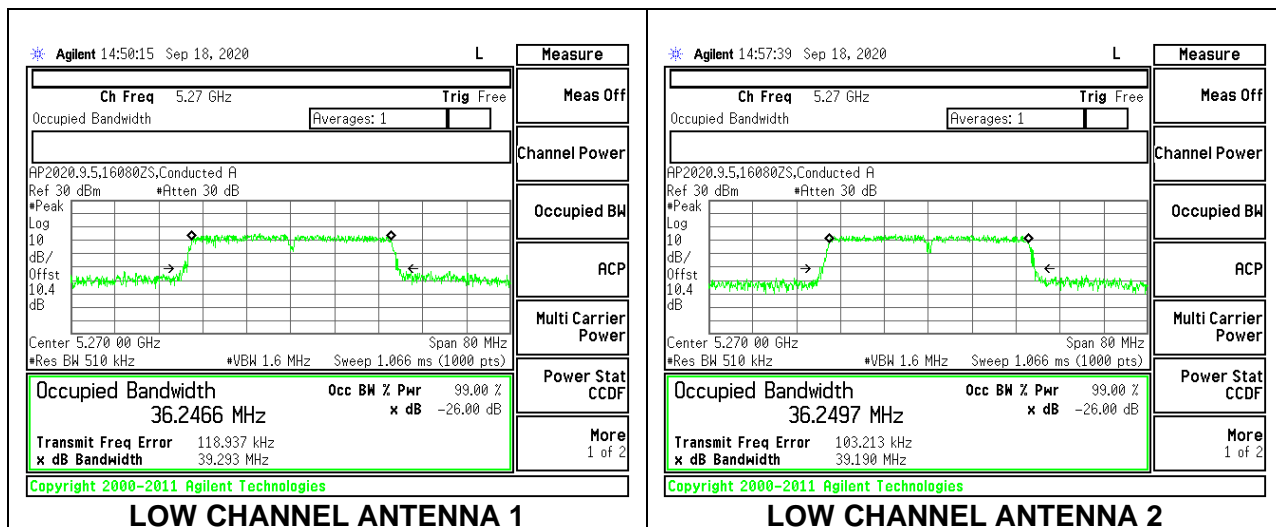

#### HIGH CHANNEL

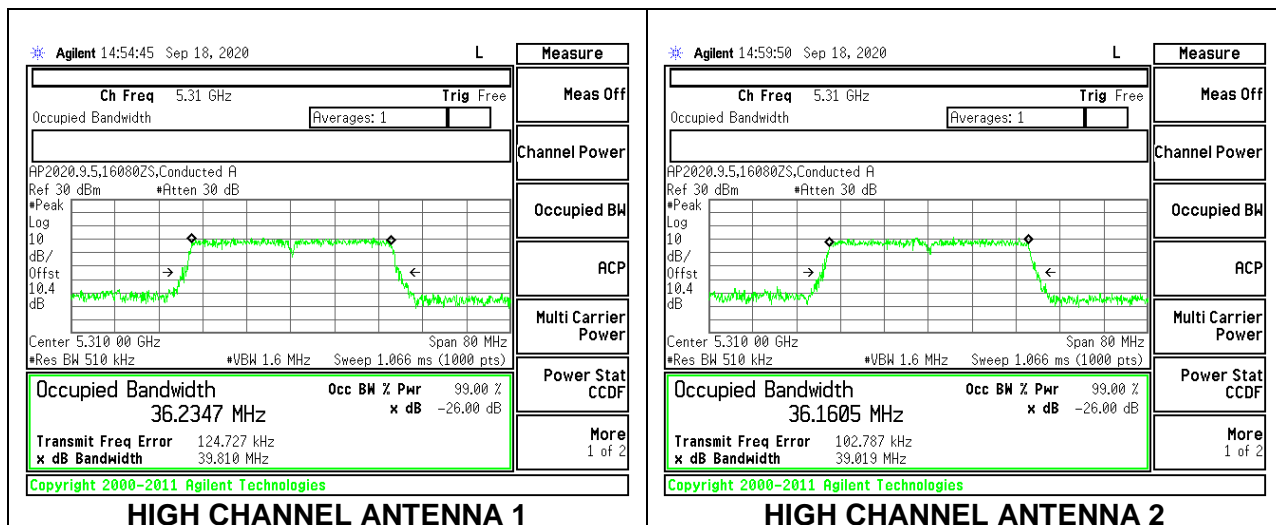

### 9.3.6. 802.11ac VHT80 MODE IN THE 5.3 GHz BAND

#### 2TX Antenna 1 + Antenna 2 CDD MODE

Channel	Frequency (MHz)	99% Bandwidth Antenna 1 (MHz)	99% Bandwidth Antenna 2 (MHz)
Mid	5290	75.273	75.420

#### MID CHANNEL

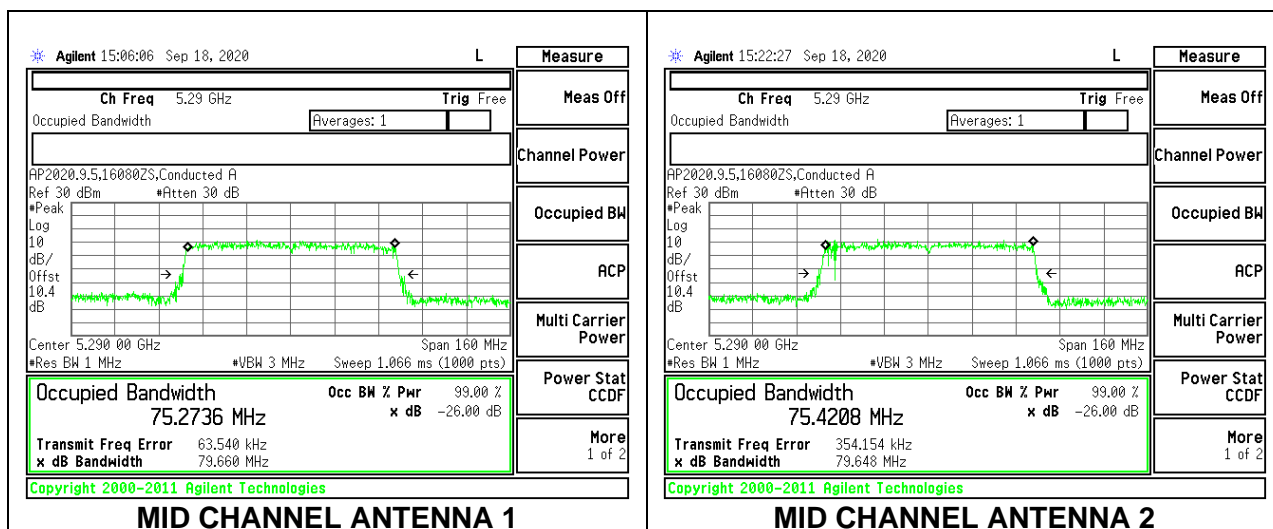



### 9.3.7. 802.11n HT20 MODE IN THE 5.6 GHz BAND

#### 2TX Antenna 1 + Antenna 2 CDD MODE

Channel	Frequency (MHz)	99% Bandwidth Antenna 1 (MHz)	99% Bandwidth Antenna 2 (MHz)
Low	5500	17.833	17.899
Mid	5580	17.512	17.403
High	5700	17.780	17.729
144	5720	17.841	17.773
144	5720*	13.920	13.890

\*Portion of UNII 2C Band

#### LOW CHANNEL

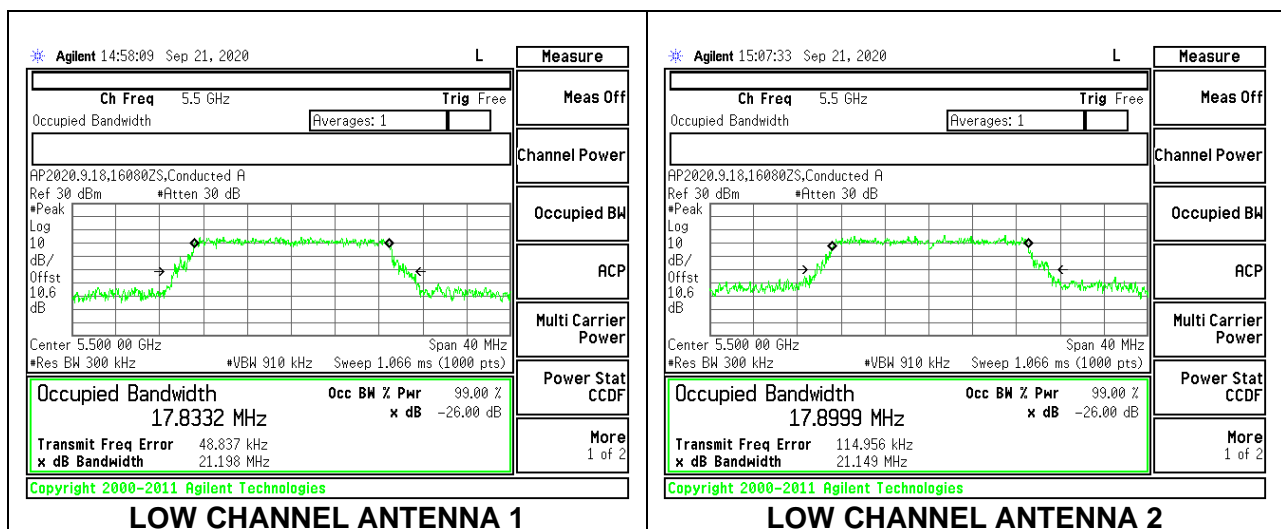

#### MID CHANNEL

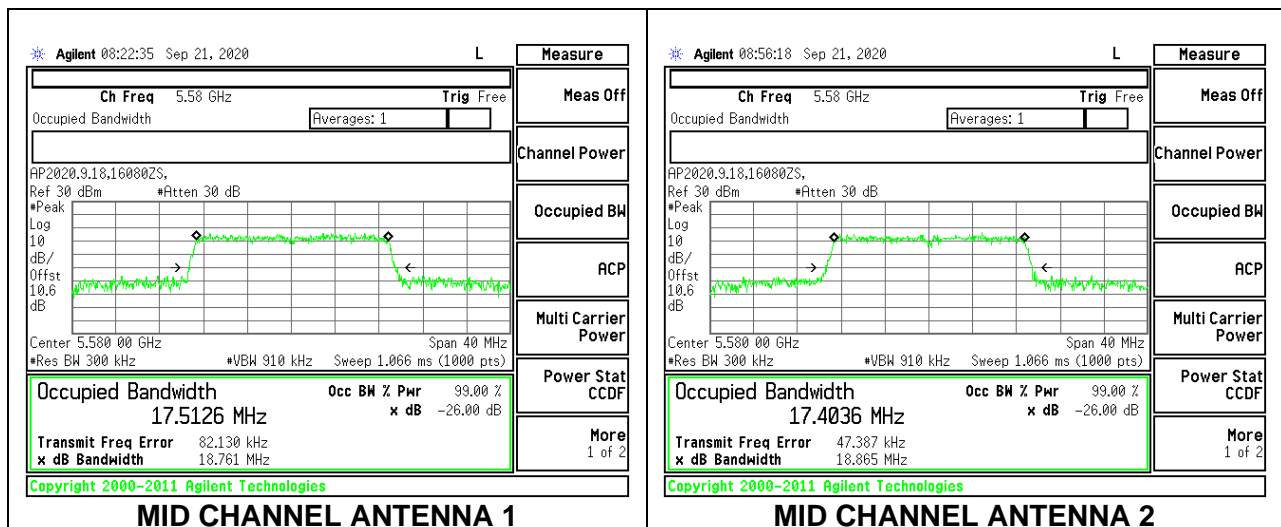

### HIGH CHANNEL

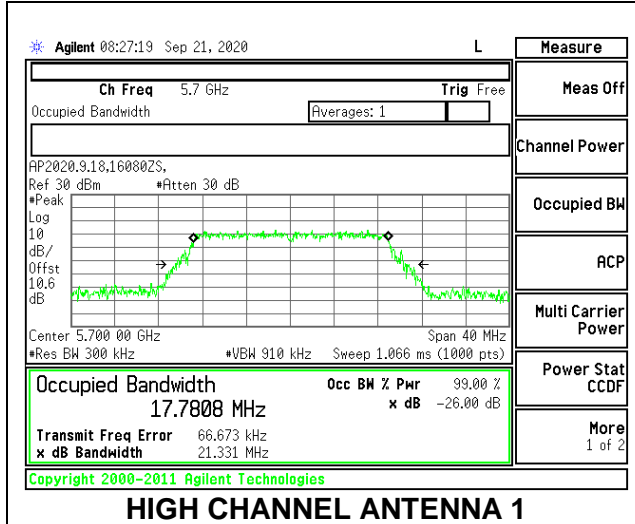

**HIGH CHANNEL ANTENNA 1**

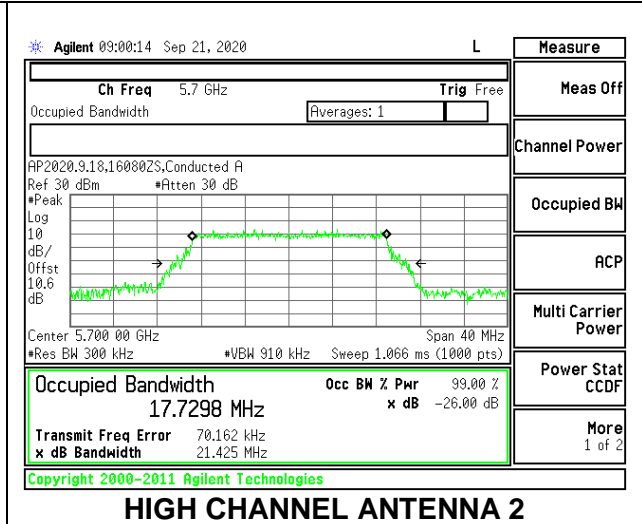

**HIGH CHANNEL ANTENNA 2**

### CHANNEL 144

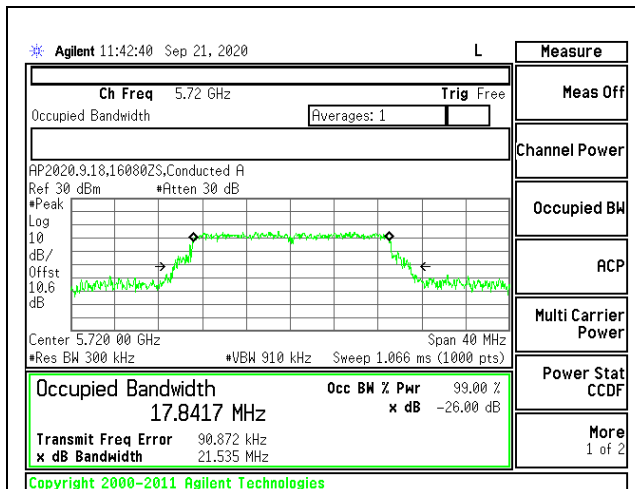

**CHANNEL 144 ANTENNA 1**

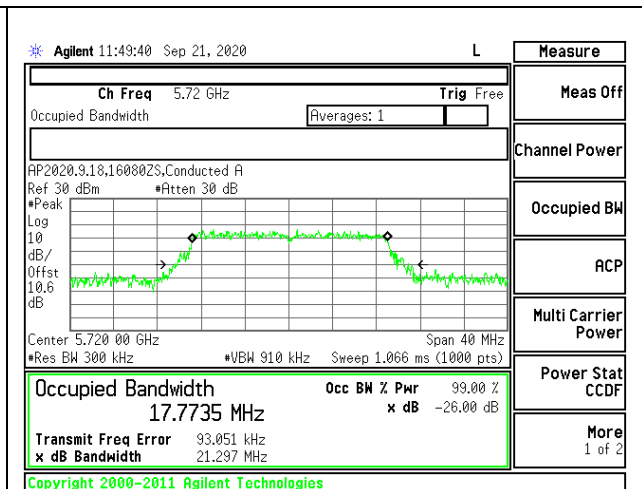

**CHANNEL 144 ANTENNA 2**

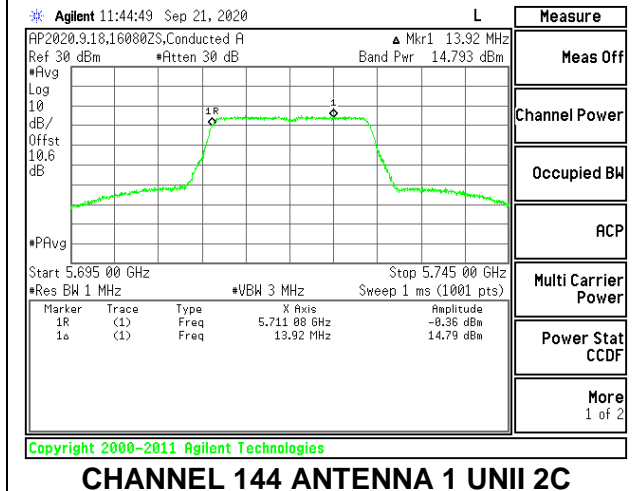

**CHANNEL 144 ANTENNA 1 UUII 2C**

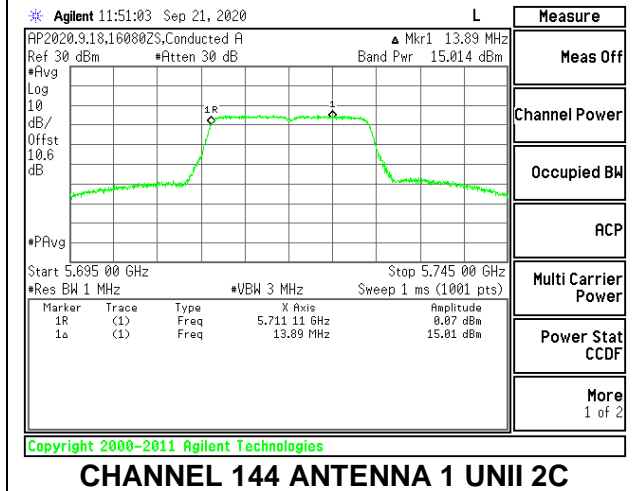

**CHANNEL 144 ANTENNA 2 UUII 2C**

### 9.3.8. 802.11n HT40 MODE IN THE 5.6 GHz BAND

#### 2TX Antenna 1 + Antenna 2 CDD MODE

Channel	Frequency (MHz)	99% Bandwidth Antenna 1 (MHz)	99% Bandwidth Antenna 2 (MHz)
Low	5510	36.178	36.205
Mid	5550	36.267	36.409
High	5670	36.212	36.221
142	5710	36.532	36.453
142	5710*	33.140	33.140

\*Portion of UNII 2C Band

#### LOW CHANNEL

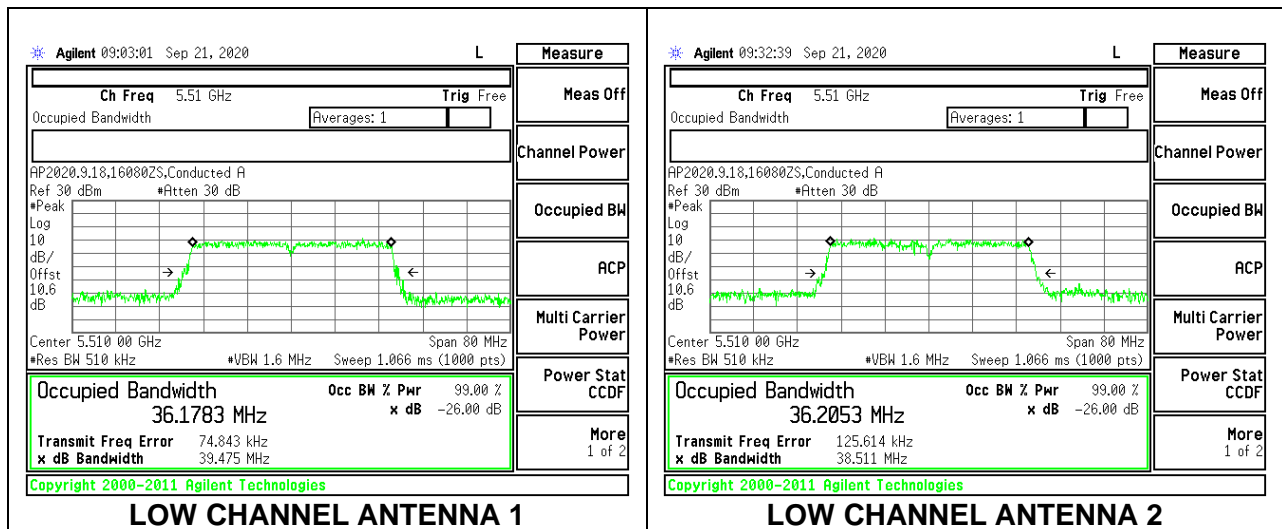

#### MID CHANNEL

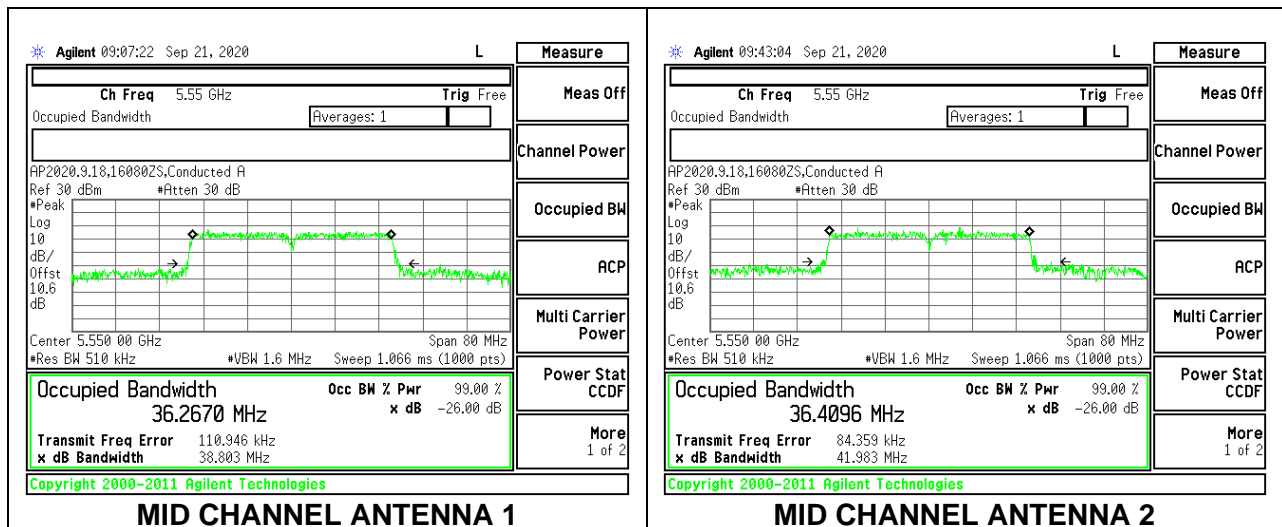

**HIGH CHANNEL**

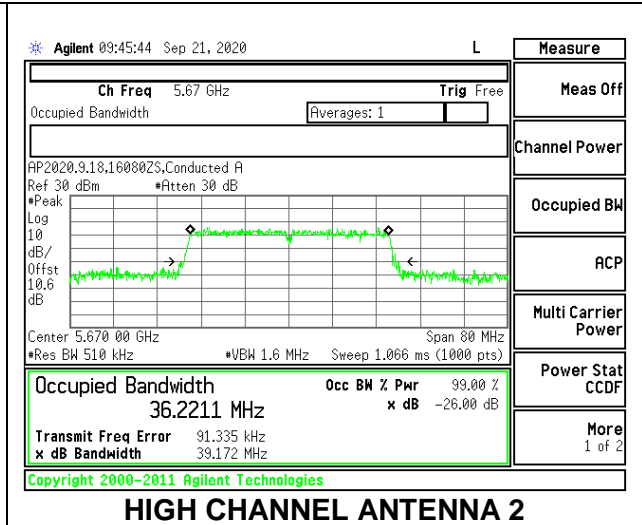
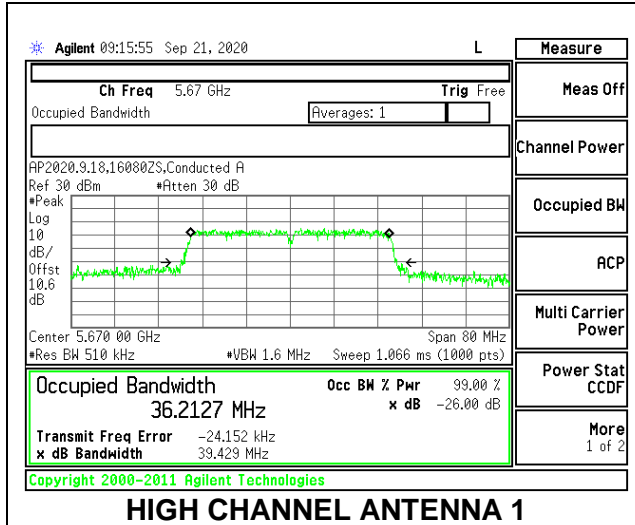

**CHANNEL 142**

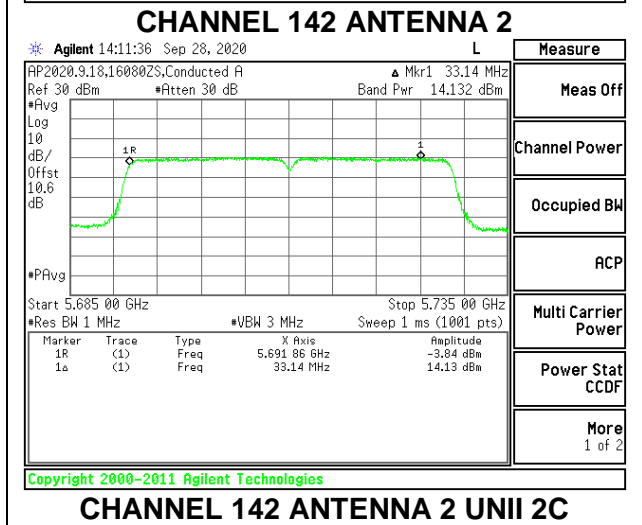
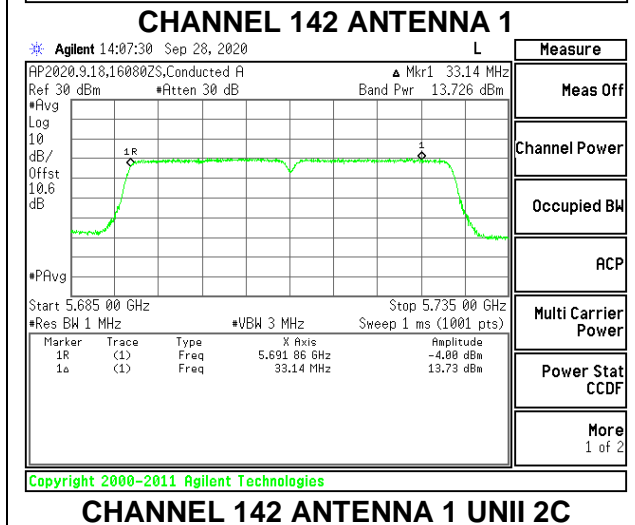
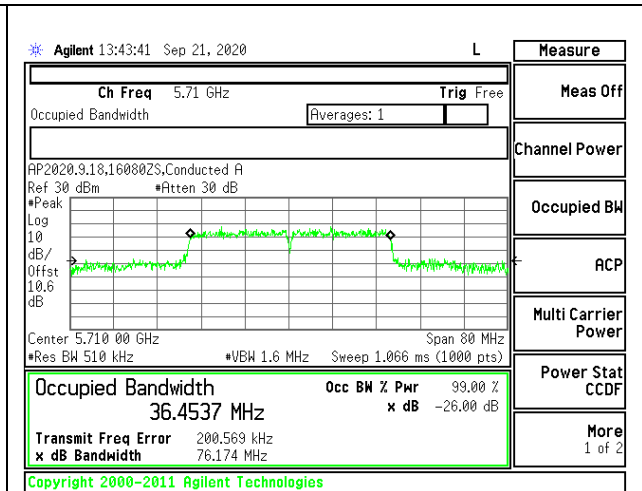
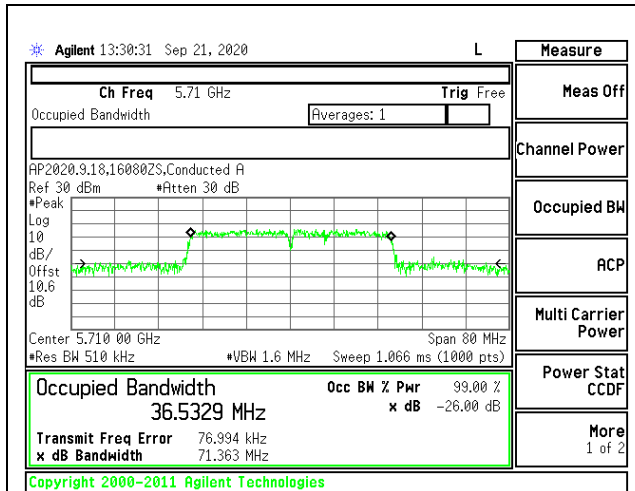

### 9.3.9. 802.11ac VHT80 MODE IN THE 5.6 GHz BAND

#### 2TX Antenna 1 + Antenna 2 CDD MODE

Channel	Frequency (MHz)	99% Bandwidth Antenna 1 (MHz)	99% Bandwidth Antenna 2 (MHz)
Low	5530	75.647	75.782
High	5610	75.787	75.493
138	5690	75.760	76.199
138	5690*	72.800	72.900

#### LOW CHANNEL

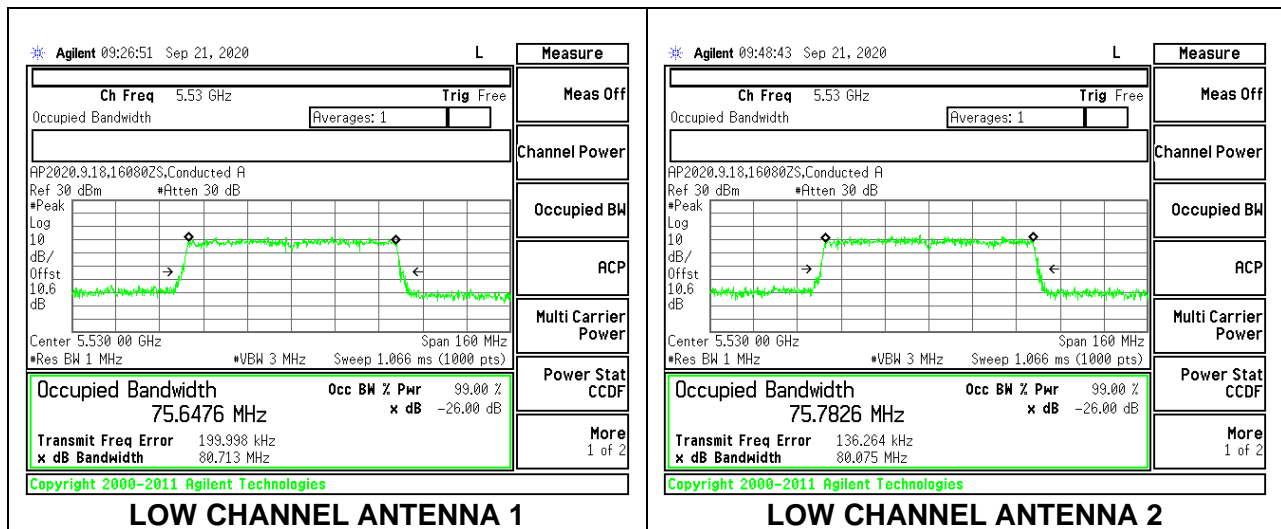

#### HIGH CHANNEL

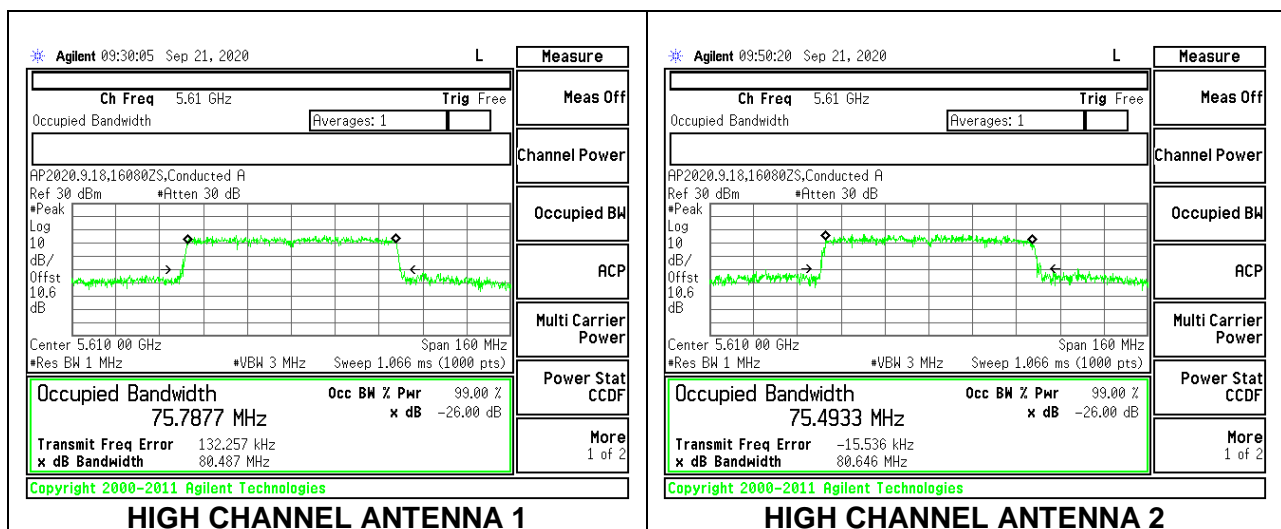

### CHANNEL 138

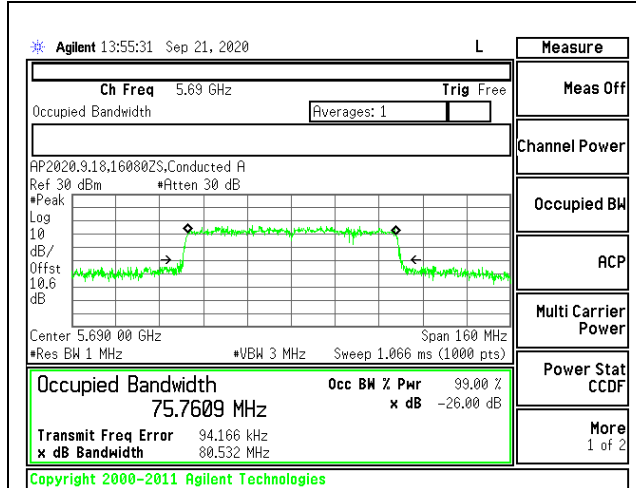

#### CHANNEL 138 ANTENNA 1

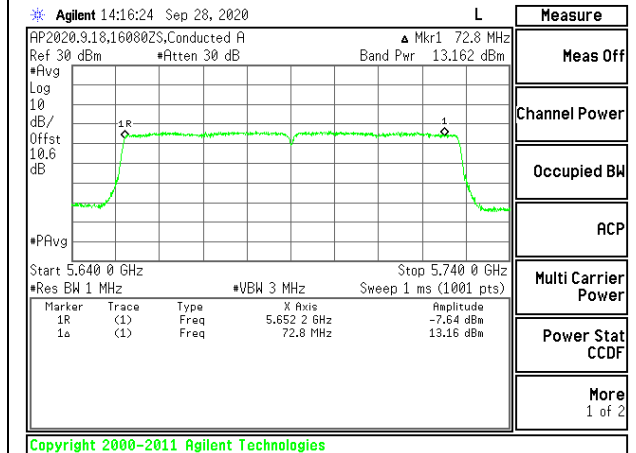

#### CHANNEL 138 ANTENNA 1 UNII 2C

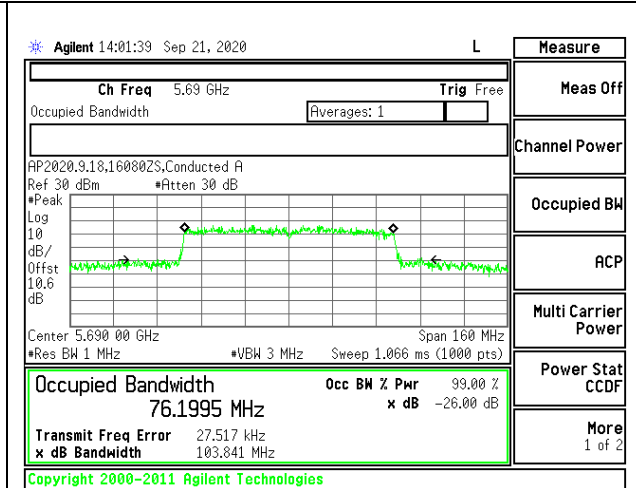

#### CHANNEL 138 ANTENNA 2

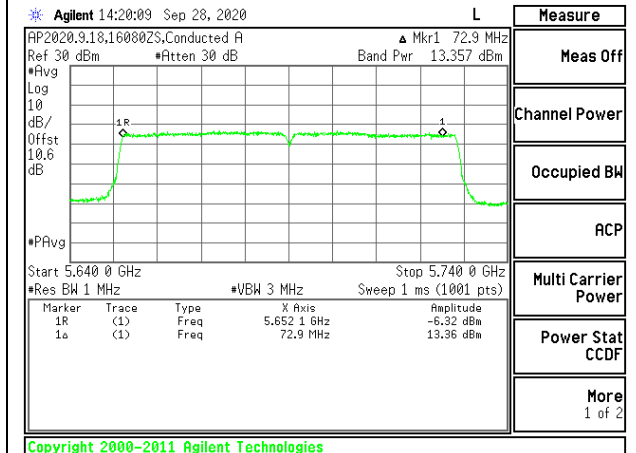

#### CHANNEL 138 ANTENNA 2 UNII 2C

### 9.3.10. 802.11n HT20 MODE IN THE 5.8 GHz BAND

#### 2TX Antenna 1 + Antenna 2 CDD MODE

Channel	Frequency (MHz)	99% Bandwidth Antenna 1 (MHz)	99% Bandwidth Antenna 2 (MHz)
Low	5745	17.909	17.906
Mid	5785	17.812	17.903
High	5825	17.840	17.897

#### LOW CHANNEL

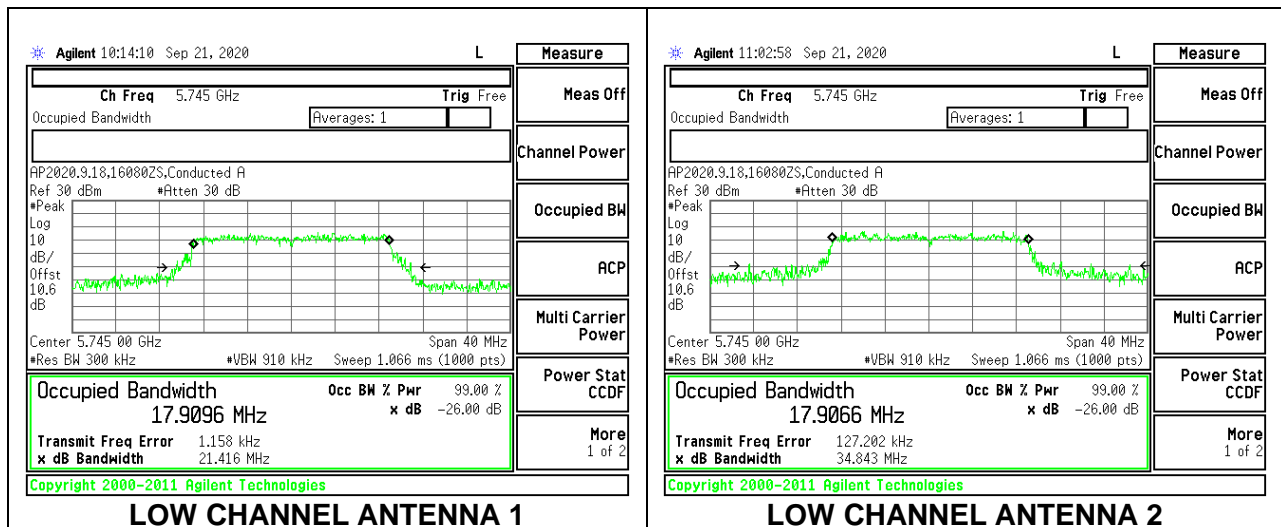

#### MID CHANNEL

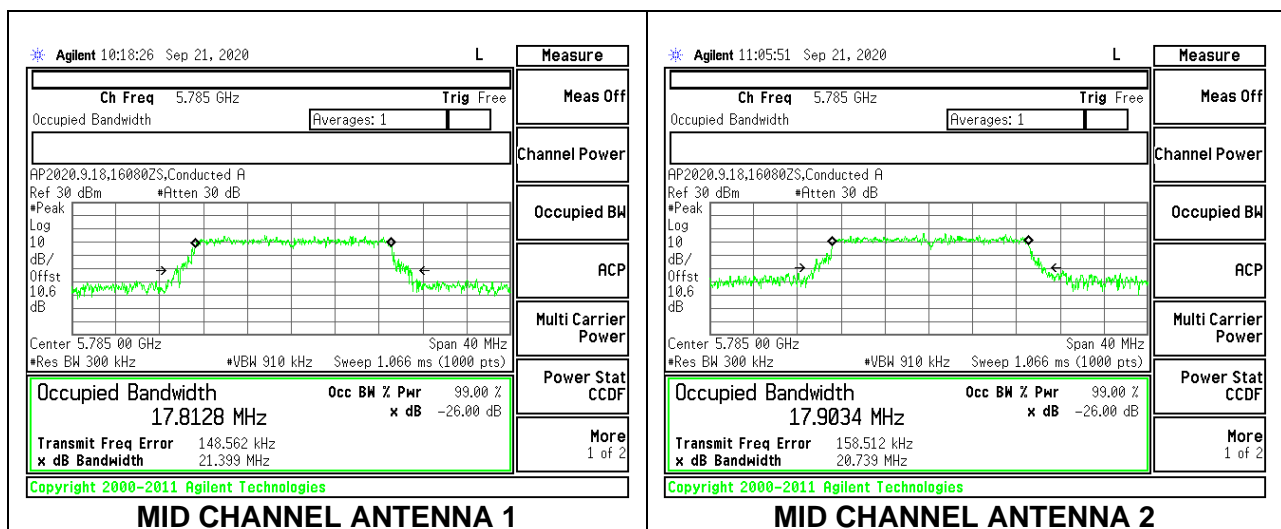

### HIGH CHANNEL

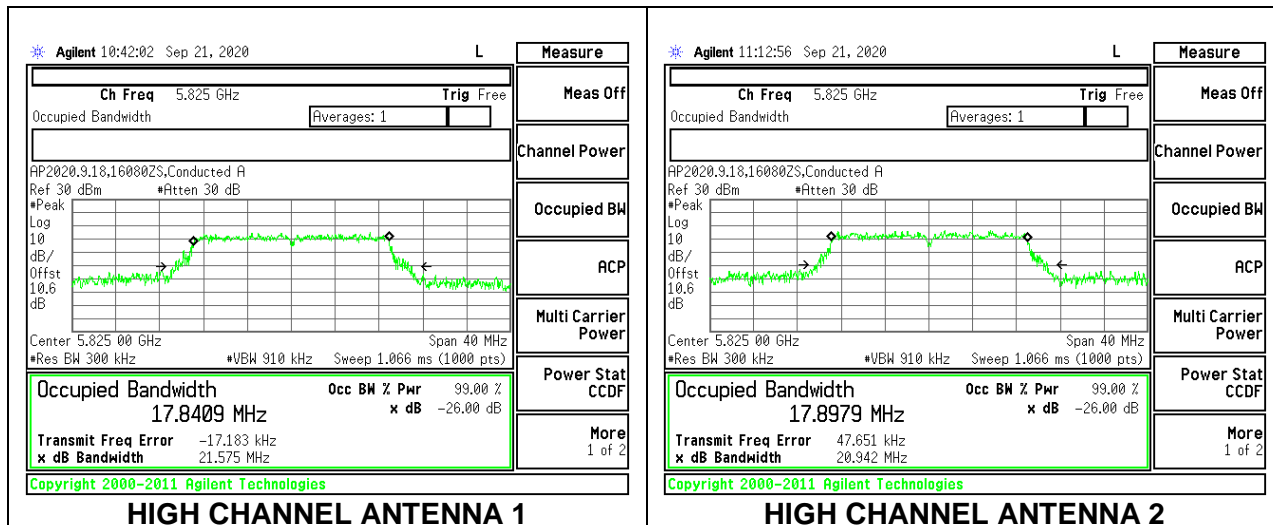



### 9.3.11. 802.11n HT40 MODE IN THE 5.8 GHz BAND

#### 2TX Antenna 1 + Antenna 2 CDD MODE

Channel	Frequency (MHz)	99% Bandwidth Antenna 1 (MHz)	99% Bandwidth Antenna 2 (MHz)
Low	5755	36.311	36.456
High	5795	36.422	36.506

#### LOW CHANNEL

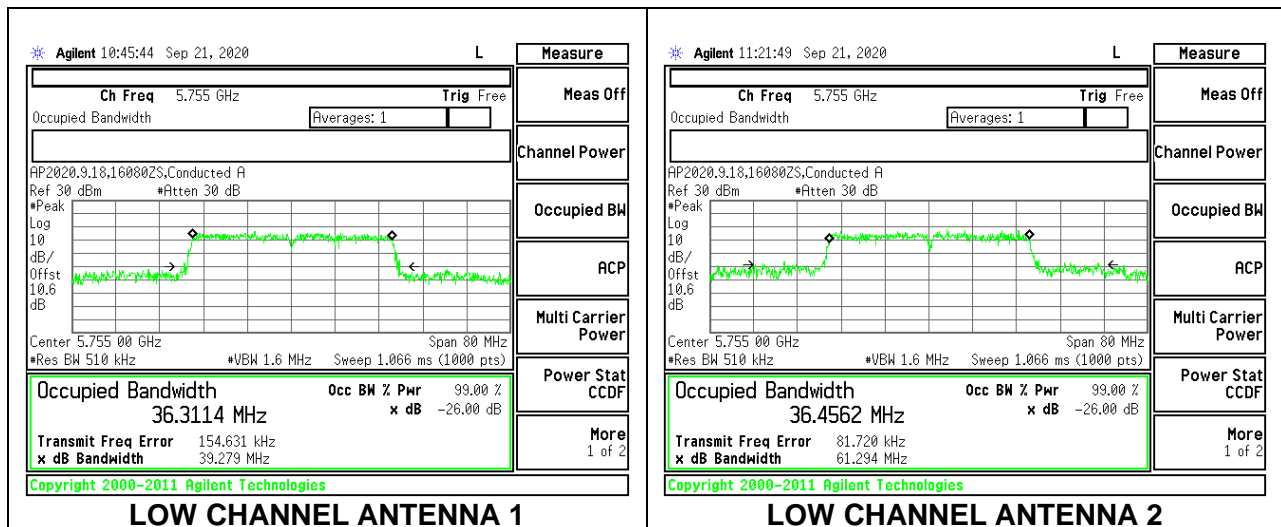

#### HIGH CHANNEL

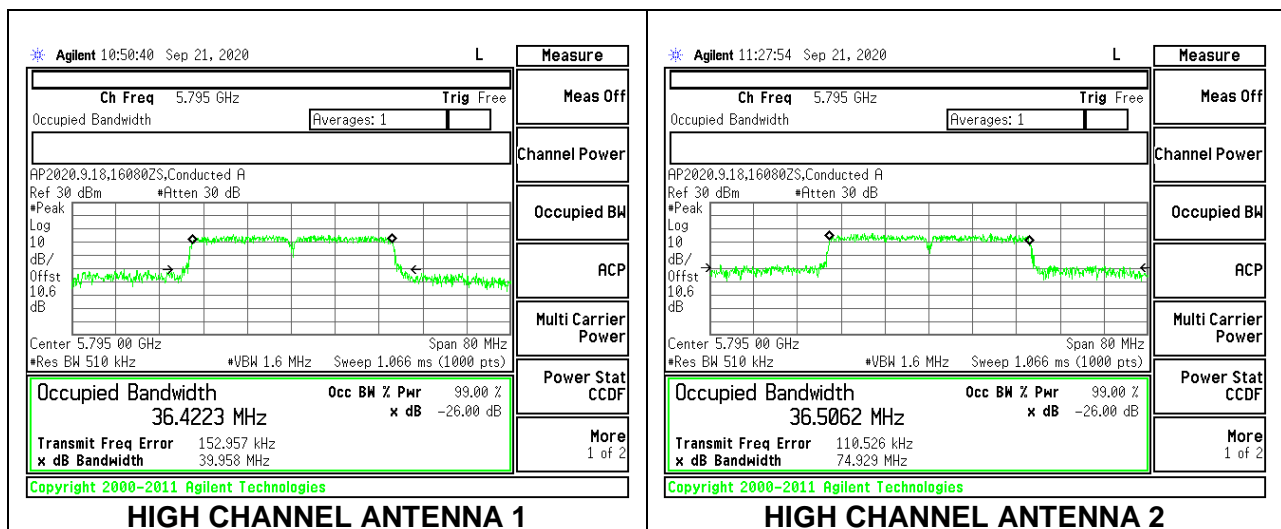

### 9.3.12. 802.11ac VHT80 MODE IN THE 5.8 GHz BAND

#### 2TX Antenna 1 + Antenna 2 CDD MODE

Channel	Frequency (MHz)	99% Bandwidth Antenna 1 (MHz)	99% Bandwidth Antenna 2 (MHz)
Mid	5775	75.634	75.716

#### MID CHANNEL

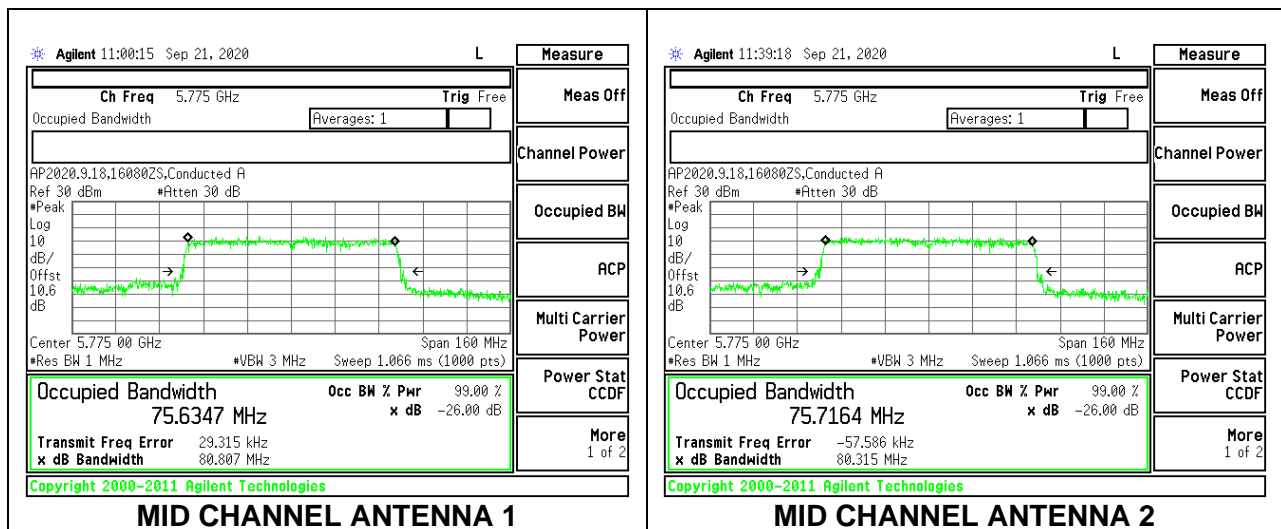

### 9.4. 6 dB BANDWIDTH

#### LIMITS

FCC §15.407 (e)

The minimum 6 dB bandwidth shall be at least 500 kHz.

#### RESULTS

##### 9.4.1. 802.11n HT20 MODE IN THE 5.8 GHz BAND

##### 2TX Antenna 1 + Antenna 2 CDD MODE

Channel	Frequency (MHz)	6 dB BW Antenna 1 (MHz)	6 dB BW Antenna 2 (MHz)	Minimum Limit (MHz)
Low	5745	17.605	17.715	0.5
Mid	5785	17.782	17.617	0.5
High	5825	17.623	17.611	0.5
144	5720	3.903	4.025	0.5

#### LOW CHANNEL

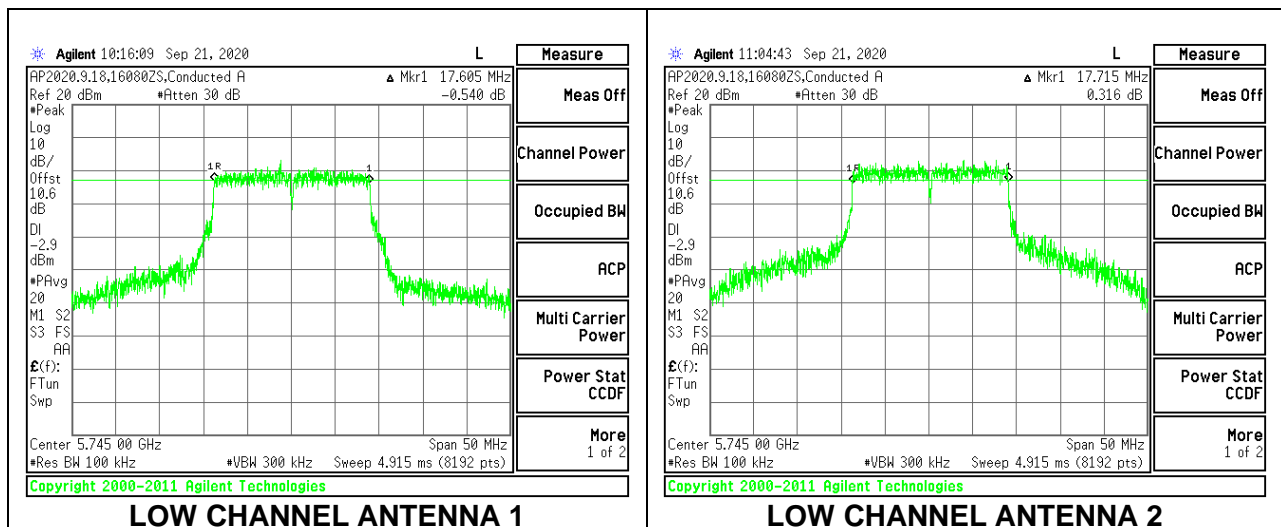

### MID CHANNEL

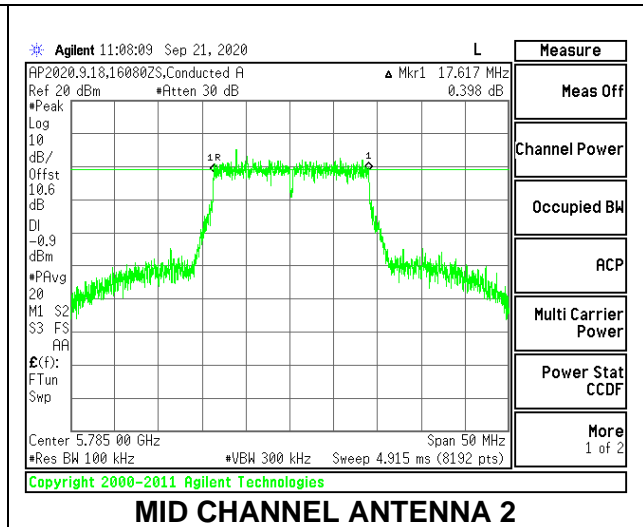
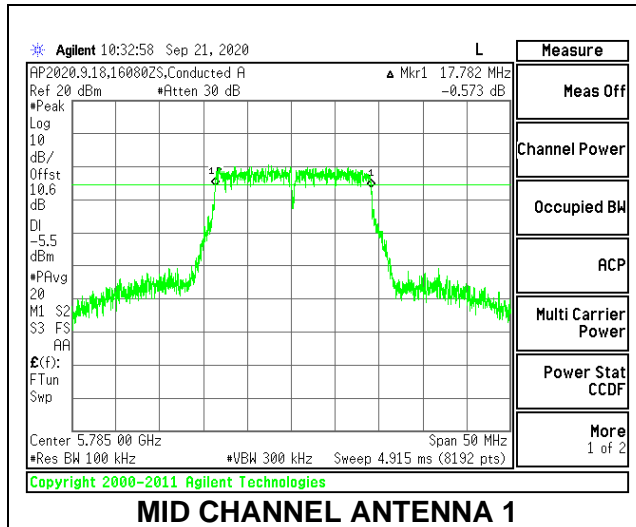

### HIGH CHANNEL

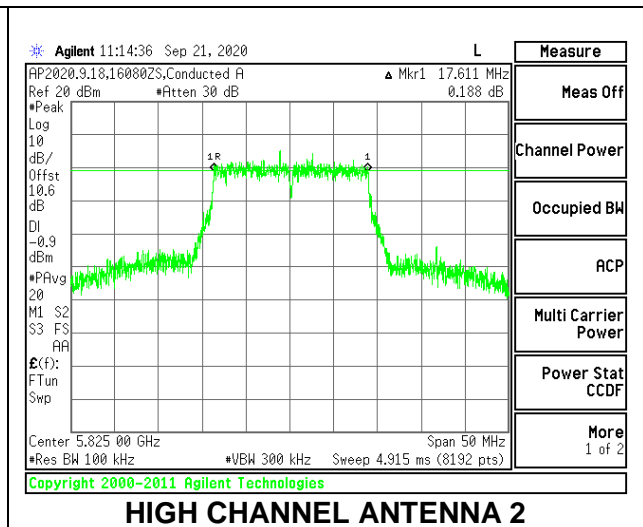
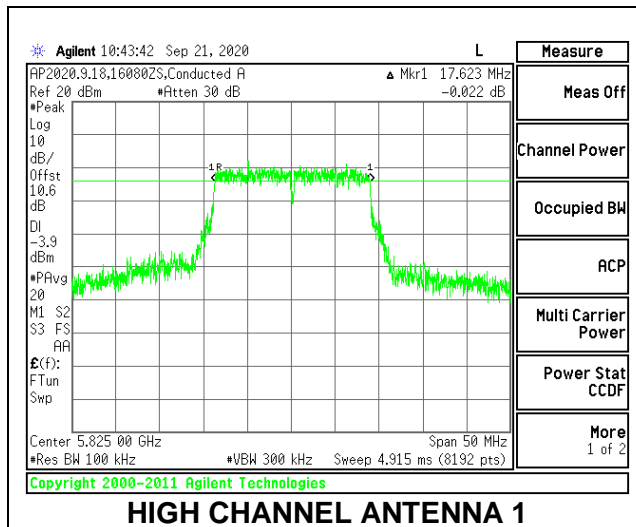

### CHANNEL 144

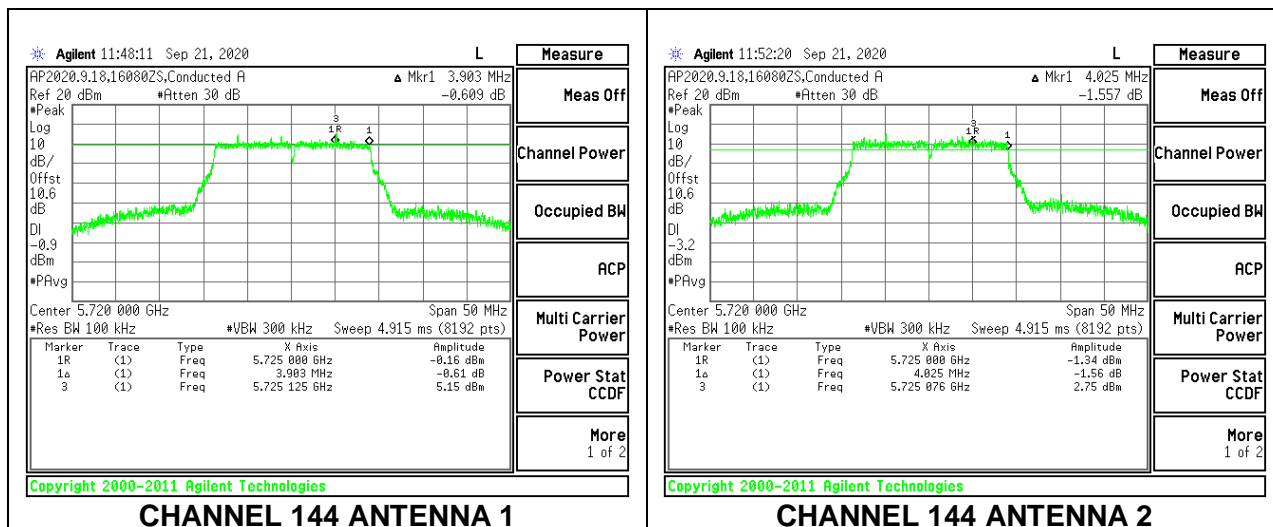

### 9.4.2. 802.11n HT40 MODE IN THE 5.8 GHz BAND

#### 2TX Antenna 1 + Antenna 2 CDD MODE

Channel	Frequency (MHz)	6 dB BW Antenna 1 (MHz)	6 dB BW Antenna 2 (MHz)	Minimum Limit (MHz)
Low	5755	35.966	36.381	0.5
High	5795	36.210	36.369	0.5
142	5710	3.392	3.356	0.5

#### LOW CHANNEL

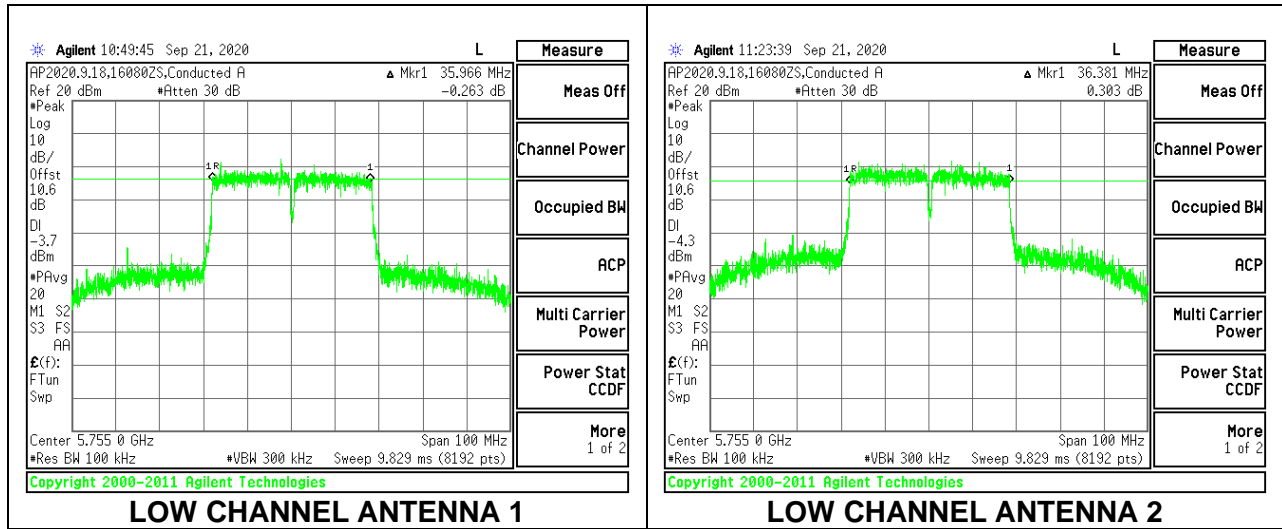

#### HIGH CHANNEL

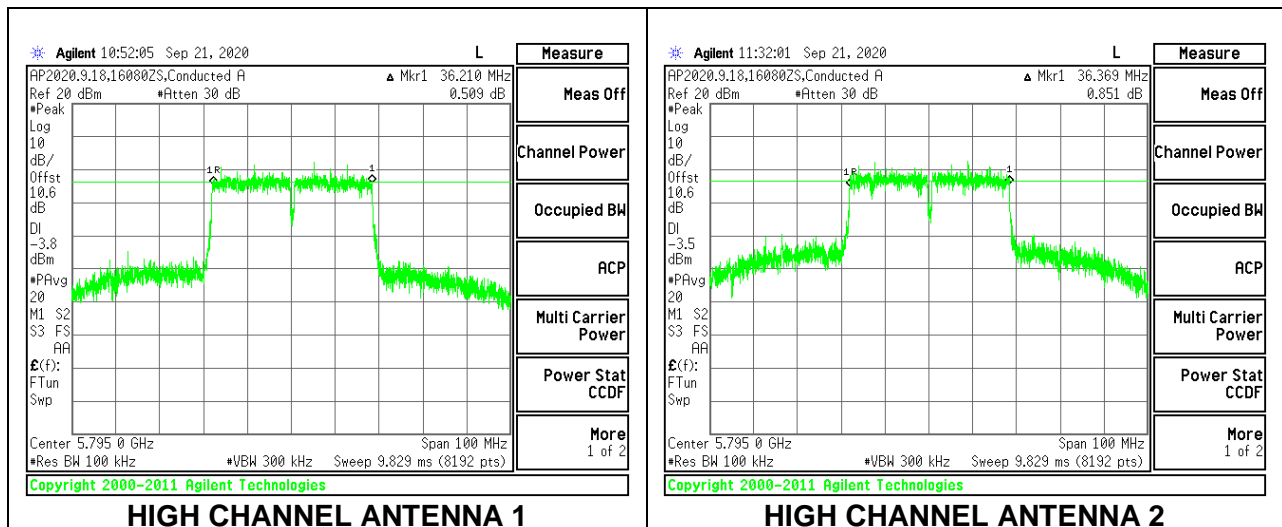

### CHANNEL 142

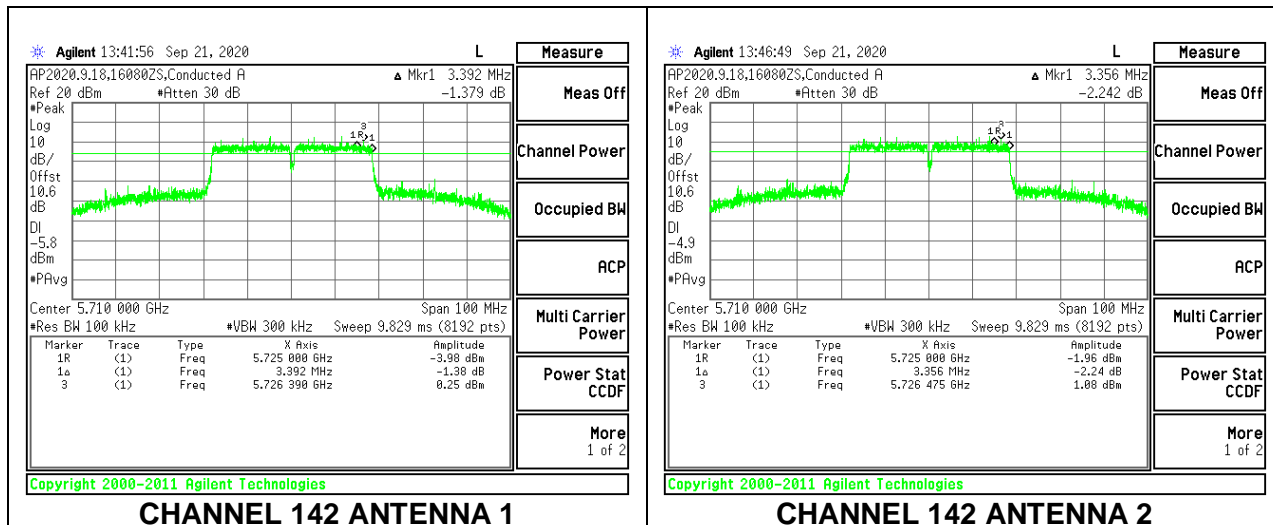

### 9.4.3. 802.11ac VHT80 MODE IN THE 5.8 GHz BAND

#### 2TX Antenna 1 + Antenna 2 CDD MODE

Channel	Frequency (MHz)	6 dB BW Antenna 1 (MHz)	6 dB BW Antenna 2 (MHz)	Minimum Limit (MHz)
Mid	5775	74.741	75.766	0.5
138	5690	3.274	3.298	0.5

#### MID CHANNEL

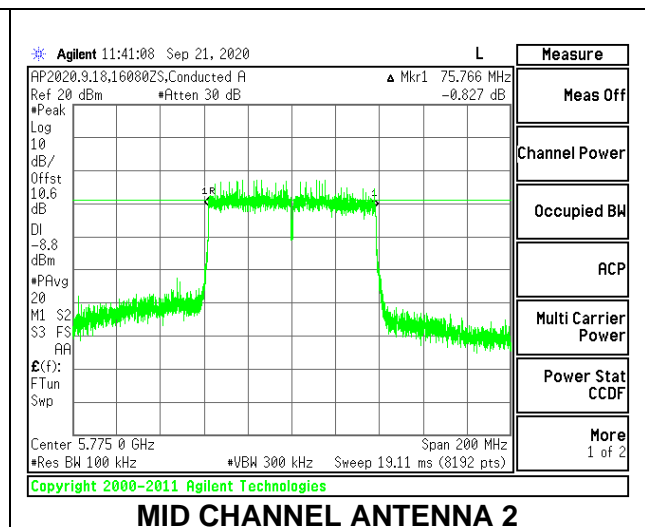
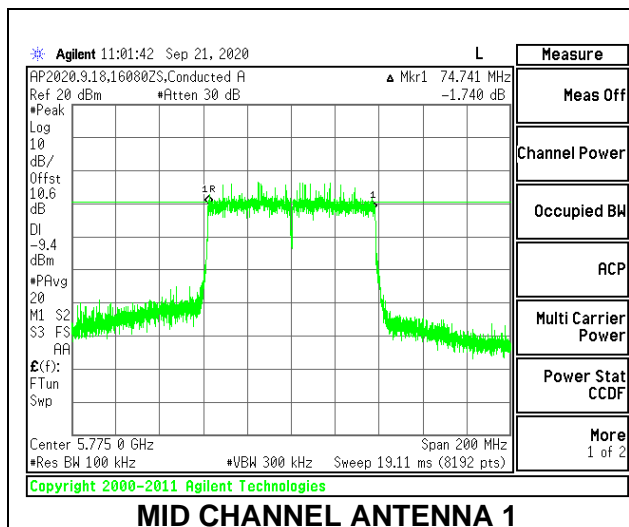

#### CHANNEL 138

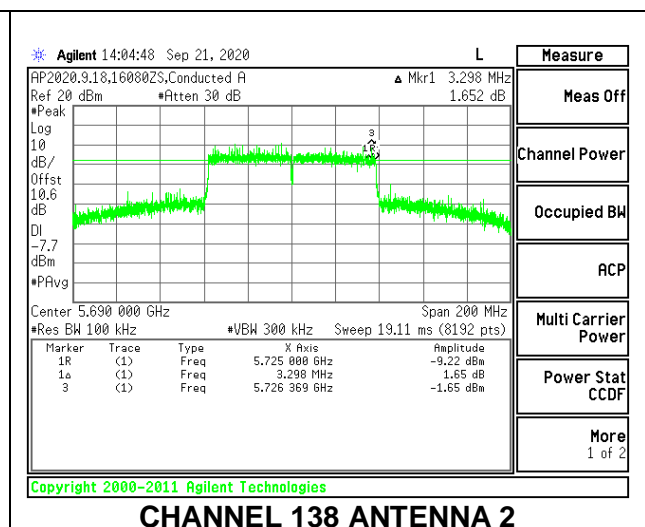
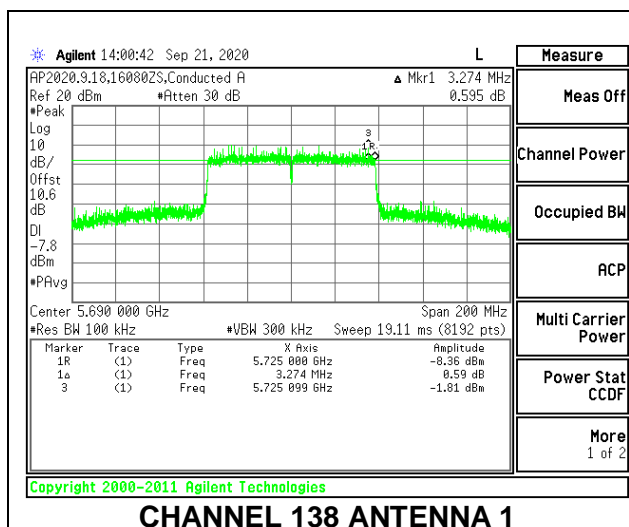



## 9.5. OUTPUT POWER AND PSD

### LIMITS

#### **FCC §15.407**

##### **Band 5.15–5.25 GHz**

(iv) For client devices in the 5.15-5.25 GHz band, the maximum conducted output power over the frequency band of operation shall not exceed 250 mW provided the maximum antenna gain does not exceed 6 dBi. In addition, the maximum power spectral density shall not exceed 11 dBm in any 1 megahertz band. If transmitting antennas of directional gain greater than 6 dBi are used, both the maximum conducted output power and the maximum power spectral density shall be reduced by the amount in dB that the directional gain of the antenna exceeds 6 dBi.

##### **Bands 5.25-5.35 GHz and 5.47-5.725 GHz**

The maximum conducted output power over the frequency bands of operation shall not exceed the lesser of 250 mW or  $11 \text{ dBm} + 10 \log B$ , where B is the 26 dB emission bandwidth in megahertz. In addition, the maximum power spectral density shall not exceed 11 dBm in any 1 megahertz band. If transmitting antennas of directional gain greater than 6 dBi are used, both the maximum conducted output power and the maximum power spectral density shall be reduced by the amount in dB that the directional gain of the antenna exceeds 6 dBi.

##### **Band 5.725-5.85 GHz**

The maximum conducted output power over the frequency band of operation shall not exceed 1 W. In addition, the maximum power spectral density shall not exceed 30 dBm in any 500-kHz band. If transmitting antennas of directional gain greater than 6 dBi are used, both the maximum conducted output power and the maximum power spectral density shall be reduced by the amount in dB that the directional gain of the antenna exceeds 6 dBi. However, fixed point-to-point U-NII devices operating in this band may employ transmitting antennas with directional gain greater than 6 dBi without any corresponding reduction in transmitter conducted power. Fixed, point-to-point operations exclude the use of point-to-multipoint systems, omnidirectional applications, and multiple collocated transmitters transmitting the same information.

### TEST PROCEDURE

The measurement method used for output power is KDB 789033 D02 v02r01, Section E.3.b (Method PM-G) and for straddles channels KDB 789033 D02 v02r01, Section E.2.b (Method SA-1) was used.

The measurement method used for power spectral density is KDB 789033 D02 v02r01, Section F

**DIRECTIONAL ANTENNA GAIN**

For 2 TX:

Tx chains are uncorrelated for power and correlated for PSD due to the device supporting CDD in all MIMO modes. The directional gains are as follows:

<b>Band (GHz)</b>	<b>Antenna 1 Antenna Gain (dBi)</b>	<b>Antena 2 Antenna Gain (dBi)</b>	<b>Uncorrelated Chains Directional Gain (dBi)</b>	<b>Correlated Chains Directional Gain (dBi)</b>
5.2	1.79	3.14	2.52	5.50
5.3	1.92	3.18	2.60	5.58
5.6	4.16	4.21	4.19	7.20
5.8	3.88	4.86	4.40	7.39

**RESULTS**

**9.5.1. 802.11n HT20 MODE IN THE 5.2 GHz BAND**

**2TX Antenna 1 + Antenna 2 CDD MODE (FCC)**

<b>Test Engineer:</b>	16080ZS
<b>Test Date:</b>	09/17/2020

**Antenna Gain and Limits**

Channel	Frequency (MHz)	Directional Gain for Power (dBi)	Directional Gain for PSD (dBi)	Power Limit (dBm)	PSD Limit (dBm/ 1MHz)
Low	5180	2.52	5.50	24.00	11.00
Mid	5200	2.52	5.50	24.00	11.00
High	5240	2.52	5.50	24.00	11.00

<b>Duty Cycle CF (dB)</b>	0.22	<b>Included in Calculations of Corr'd PSD</b>
---------------------------	------	---

**Output Power Results**

Channel	Frequency (MHz)	Antenna 1 Meas Power (dBm)	Antenna 2 Meas Power (dBm)	Total Corr'd Power (dBm)	Power Limit (dBm)	Power Margin (dB)
Low	5180	13.92	12.59	16.32	24.00	-7.68
Mid	5200	14.48	13.52	17.04	24.00	-6.96
High	5240	14.61	13.61	17.15	24.00	-6.85

**PSD Results**

Channel	Frequency (MHz)	Antenna 1 Meas PSD (dBm/1MHz)	Antenna 2 Meas PSD (dBm/1MHz)	Total Corr'd PSD (dBm/1MHz)	PSD Limit (dBm/ 1MHz)	PSD Margin (dB)
Low	5180	2.43	1.61	5.27	11.00	-5.73
Mid	5200	3.55	2.89	6.46	11.00	-4.54
High	5240	3.72	2.89	6.55	11.00	-4.45

### LOW CHANNEL

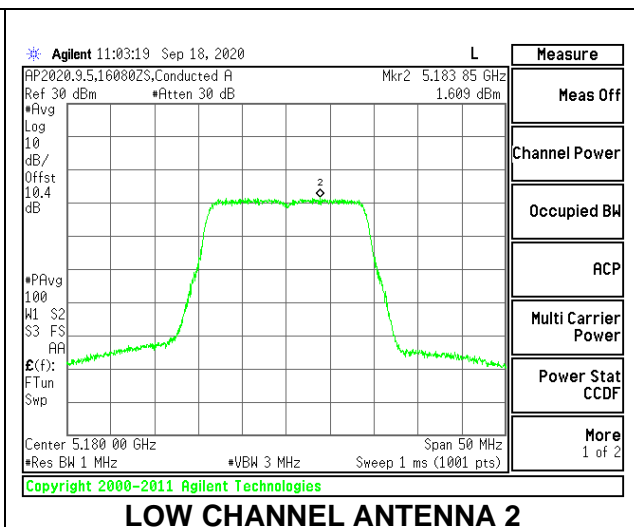
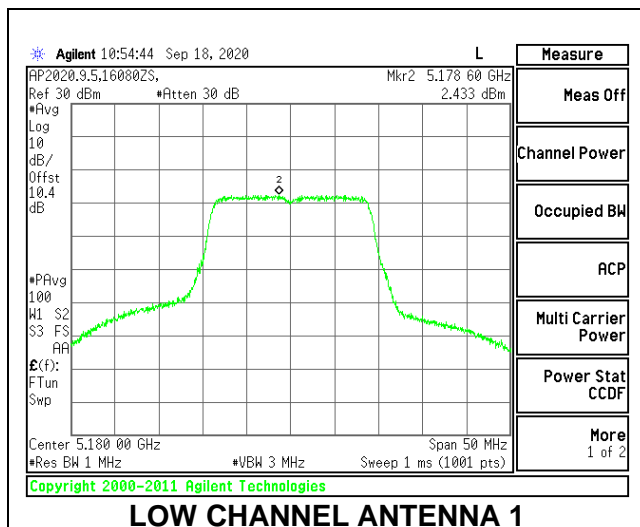

### MID CHANNEL

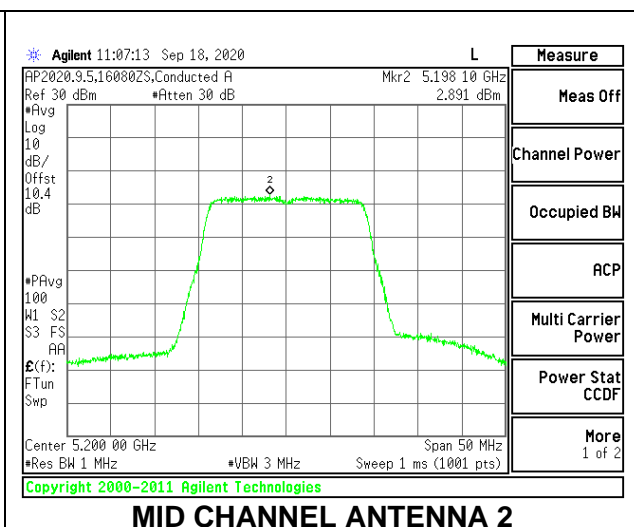
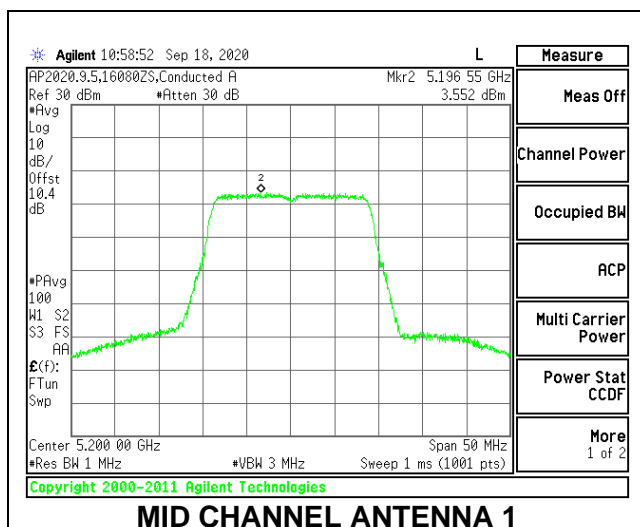

### HIGH CHANNEL

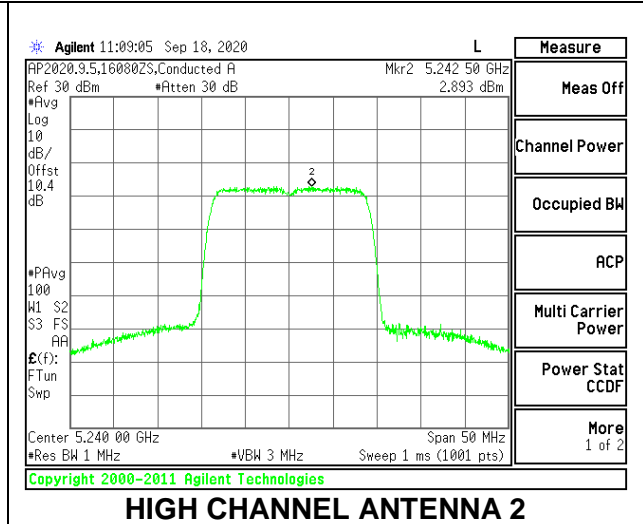
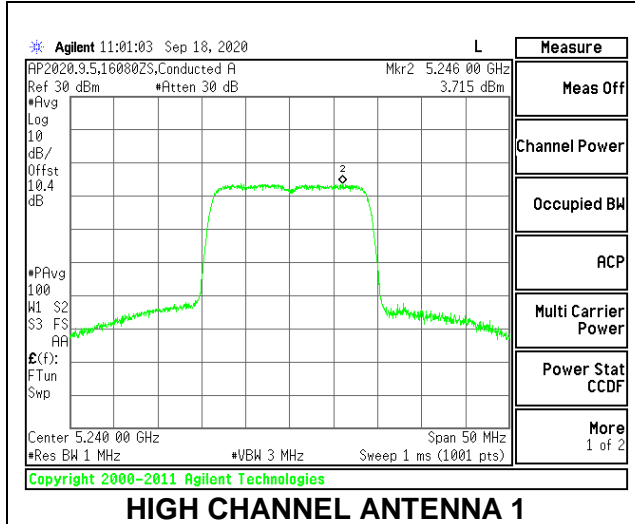

**9.5.2. 802.11n HT40 MODE IN THE 5.2 GHz BAND**

**2TX Antenna 1 + Antenna 2 CDD MODE (FCC)**

<b>Test Engineer:</b>	16080ZS
<b>Test Date:</b>	09/17/2020

**Antenna Gain and Limits**

Channel	Frequency (MHz)	Directional Gain for Power (dBi)	Directional Gain for PSD (dBi)	Power Limit (dBm)	PSD Limit (dBm/ 1MHz)
Low	5190	2.52	5.50	24.00	11.00
High	5230	2.52	5.50	24.00	11.00

<b>Duty Cycle CF (dB)</b>	0.44	<b>Included in Calculations of Corr'd PSD</b>
---------------------------	------	---

**Output Power Results**

Channel	Frequency (MHz)	Antenna 1 Meas Power (dBm)	Antenna 2 Meas Power (dBm)	Total Corr'd Power (dBm)	Power Limit (dBm)	Power Margin (dB)
Low	5190	9.17	7.68	11.50	24.00	-12.50
High	5230	14.92	13.77	17.39	24.00	-6.61

**PSD Results**

Channel	Frequency (MHz)	Antenna 1 Meas PSD (dBm/ 1MHz)	Antenna 2 Meas PSD (dBm/ 1MHz)	Total Corr'd PSD (dBm/ 1MHz)	PSD Limit (dBm/ 1MHz)	PSD Margin (dB)
Low	5190	-4.88	-6.38	-2.11	11.00	-13.11
High	5230	1.13	0.09	4.09	11.00	-6.91

### LOW CHANNEL

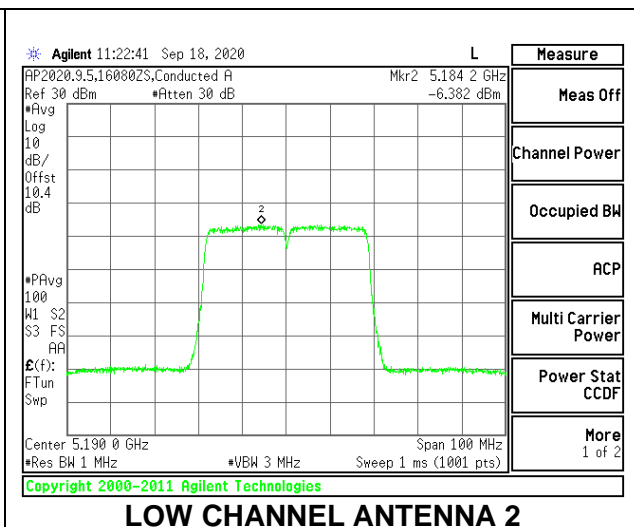
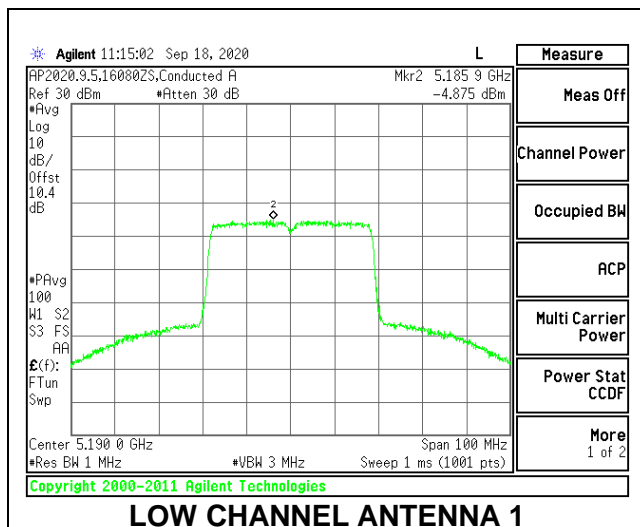

### HIGH CHANNEL

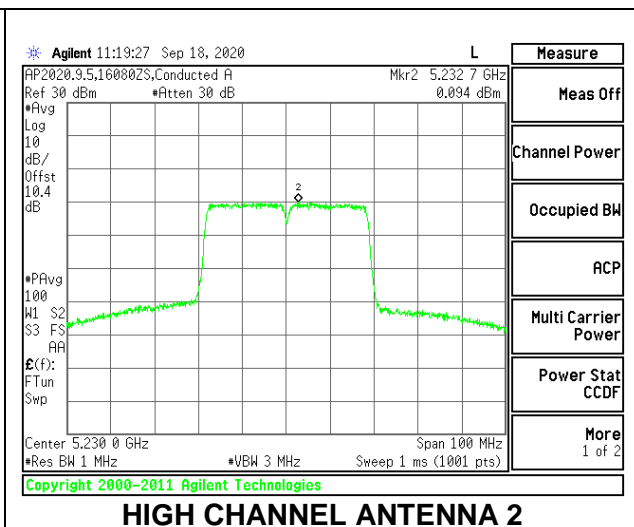
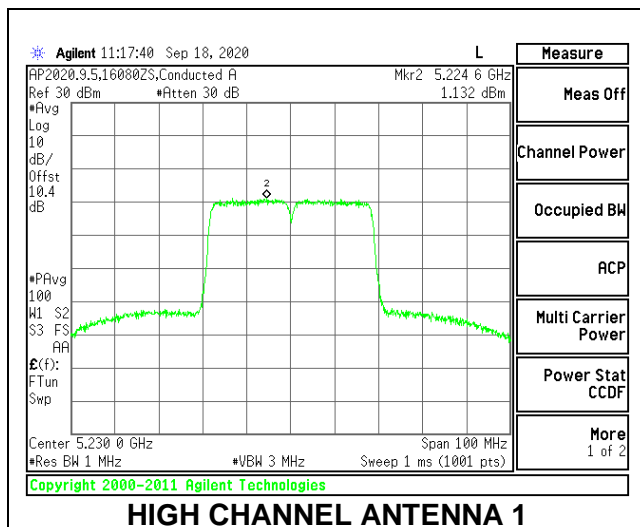

### 9.5.3. 802.11ac VHT80 MODE IN THE 5.2 GHz BAND

#### 2TX Antenna 1 + Antenna 2 CDD MODE (FCC)

Test Engineer:	16080ZS
Test Date:	09/17/2020

#### Antenna Gain and Limits

Channel	Frequency (MHz)	Directional Gain for Power (dBi)	Directional Gain for PSD (dBi)	Power Limit (dBm)	PSD Limit (dBm/1MHz)
Mid	5210	2.52	5.50	24.00	11.00

Duty Cycle CF (dB)	0.85	Included in Calculations of Corr'd PSD
--------------------	------	--

#### Output Power Results

Channel	Frequency (MHz)	Antenna 1 Meas Power (dBm)	Antenna 2 Meas Power (dBm)	Total Corr'd Power (dBm)	Power Limit (dBm)	Power Margin (dB)
Mid	5210	8.78	7.58	11.23	24.00	-12.77

#### PSD Results

Channel	Frequency (MHz)	Antenna 1 Meas PSD (dBm/1MHz)	Antenna 2 Meas PSD (dBm/1MHz)	Total Corr'd PSD (dBm/1MHz)	PSD Limit (dBm/1MHz)	PSD Margin (dB)
Mid	5210	-8.34	-9.67	-5.10	11.00	-16.10

#### MID CHANNEL

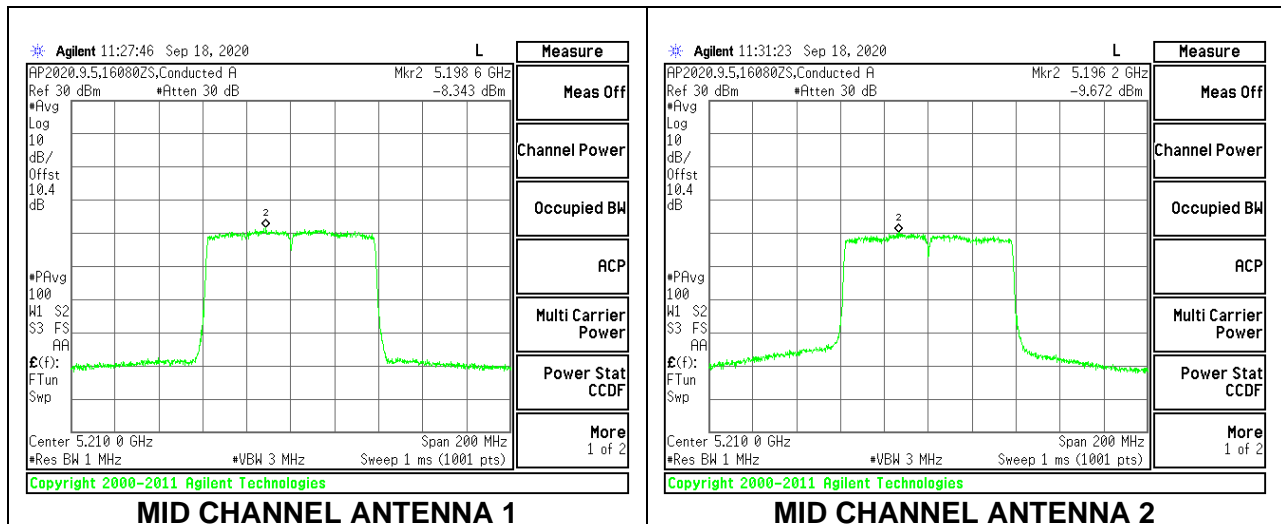



**9.5.4. 802.11n HT20 MODE IN THE 5.3 GHz BAND**

**2TX Antenna 1 + Antenna 2 CDD MODE (FCC)**

<b>Test Engineer:</b>	16080ZS
<b>Test Date:</b>	09/17/2020

**Bandwidth, Antenna Gain, and Limits**

Channel	Frequency (MHz)	Min 26 dB BW (MHz)	Directional Gain for Power (dBi)	Directional Gain for PSD (dBi)	Power Limit (dBm)	PSD Limit (dBm/1MHz)
Low	5260	19.35	2.60	5.58	23.87	11.00
Mid	5300	21.95	2.60	5.58	24.00	11.00
High	5320	22.00	2.60	5.58	24.00	11.00

<b>Duty Cycle CF (dB)</b>	0.22	<b>Included in Calculations of Corr'd PSD</b>
---------------------------	------	---

**Output Power Results**

Channel	Frequency (MHz)	Antenna 1 Meas Power (dBm)	Antenna 2 Meas Power (dBm)	Total Corr'd Power (dBm)	Power Limit (dBm)	Power Margin (dB)
Low	5260	15.00	14.77	17.90	23.87	-5.97
Mid	5300	14.87	14.92	17.91	24.00	-6.09
High	5320	14.20	13.85	17.04	24.00	-6.96

**PSD Results**

Channel	Frequency (MHz)	Antenna 1 Meas PSD (dBm/1MHz)	Antenna 2 Meas PSD (dBm/1MHz)	Total Corr'd PSD (dBm/1MHz)	PSD Limit (dBm/1MHz)	PSD Margin (dB)
Low	5260	3.85	3.73	7.02	11.00	-3.98
Mid	5300	4.17	3.86	7.25	11.00	-3.75
High	5320	3.14	3.72	6.67	11.00	-4.33

### LOW CHANNEL

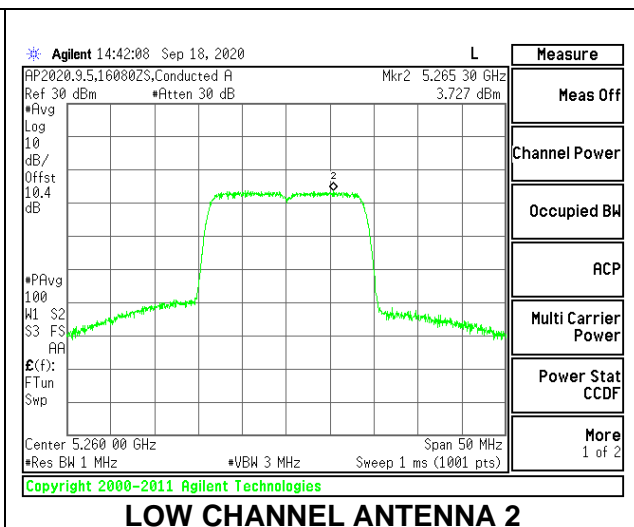
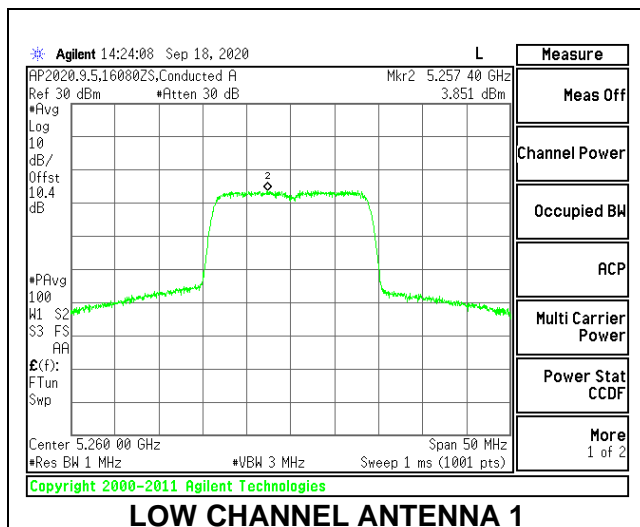

### MID CHANNEL

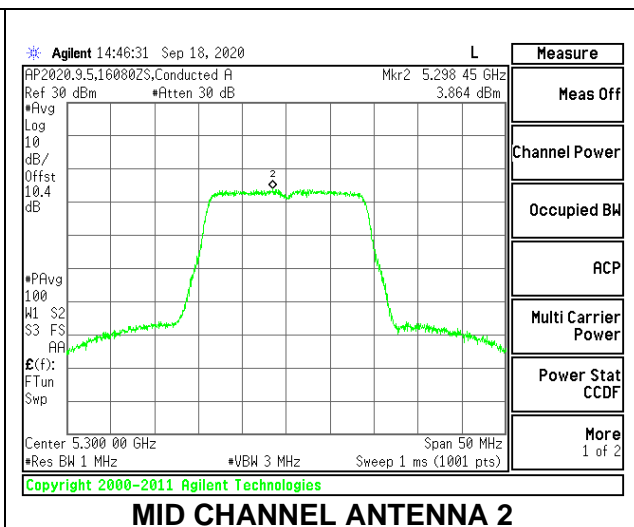
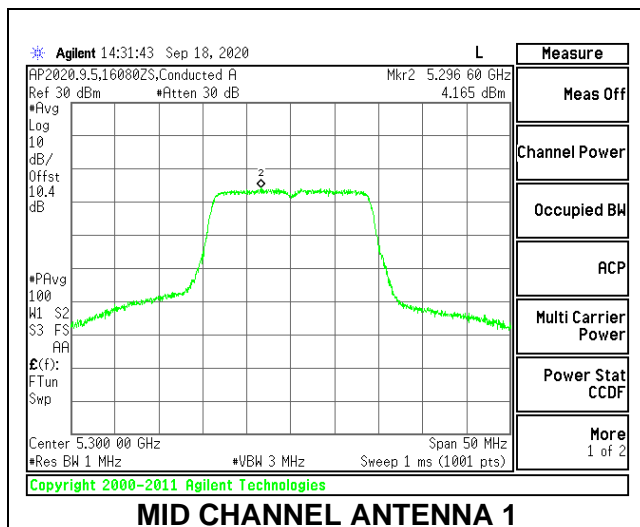

### HIGH CHANNEL

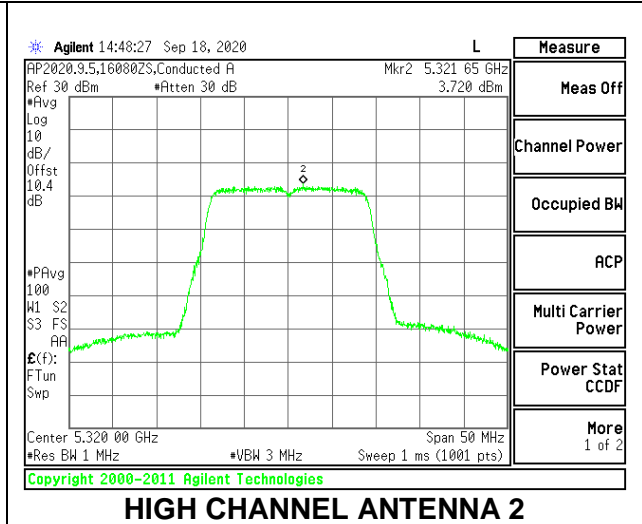
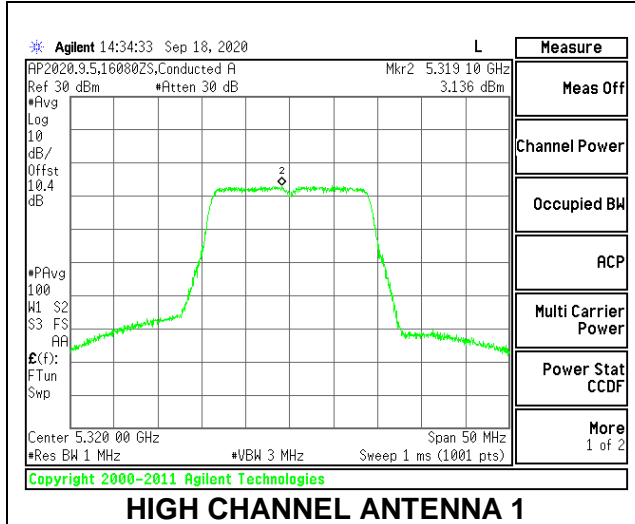

**9.5.5. 802.11n HT40 MODE IN THE 5.3 GHz BAND**

**2TX Antenna 1 + Antenna 2 CDD MODE (FCC)**

<b>Test Engineer:</b>	16080ZS
<b>Test Date:</b>	09/17/2020

**Bandwidth, Antenna Gain, and Limits**

Channel	Frequency (MHz)	Min 26 dB BW (MHz)	Directional Gain for Power (dBi)	Directional Gain for PSD (dBi)	Power Limit (dBm)	PSD Limit (dBm/1MHz)
Low	5270	40.70	2.60	5.58	24.00	11.00
High	5310	40.70	2.60	5.58	24.00	11.00

<b>Duty Cycle CF (dB)</b>	0.44	<b>Included in Calculations of Corr'd PSD</b>
---------------------------	------	---

**Output Power Results**

Channel	Frequency (MHz)	Antenna 1 Meas Power (dBm)	Antenna 2 Meas Power (dBm)	Total Corr'd Power (dBm)	Power Limit (dBm)	Power Margin (dB)
Low	5270	15.18	14.88	18.04	24.00	-5.96
High	5310	11.65	11.39	14.53	24.00	-9.47

**PSD Results**

Channel	Frequency (MHz)	Antenna 1 Meas PSD (dBm/1MHz)	Antenna 2 Meas PSD (dBm/1MHz)	Total Corr'd PSD (dBm/1MHz)	PSD Limit (dBm/1MHz)	PSD Margin (dB)
Low	5270	1.40	1.12	4.71	11.00	-6.29
High	5310	-2.66	-2.61	0.82	11.00	-10.18

### LOW CHANNEL

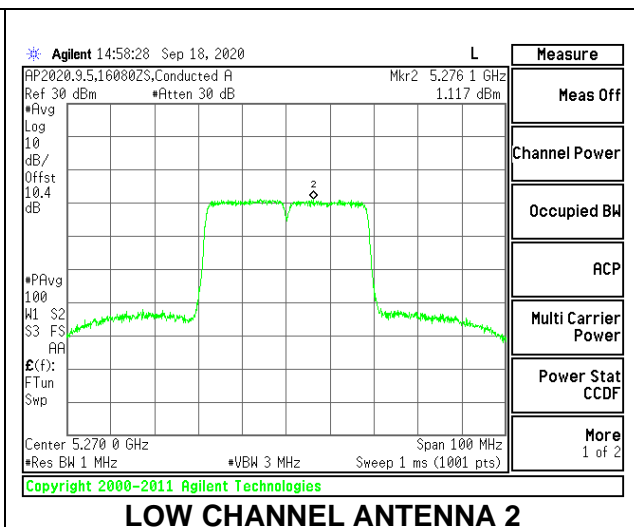
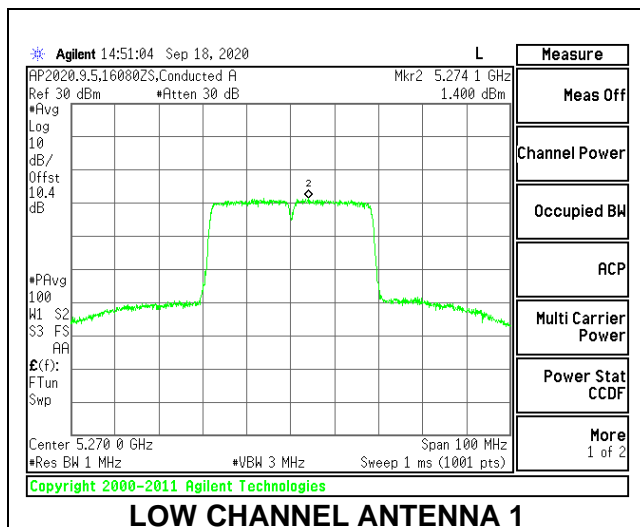

### HIGH CHANNEL

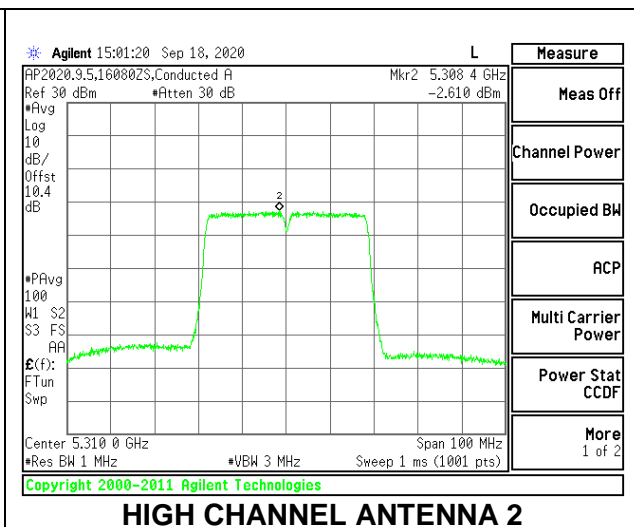
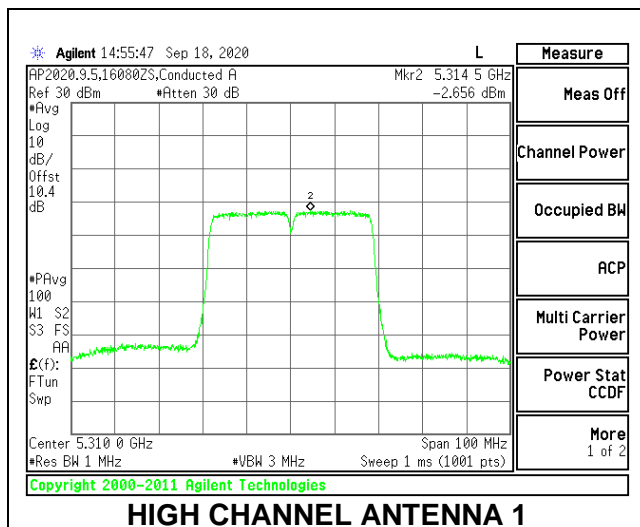

### 9.5.6. 802.11ac VHT80 MODE IN THE 5.3 GHz BAND

#### 2TX Antenna 1 + Antenna 2 CDD MODE (FCC)

Test Engineer:	16080ZS
Test Date:	09/17/2020

#### Bandwidth, Antenna Gain, and Limits

Channel	Frequency (MHz)	Min 26 dB BW (MHz)	Directional Gain for Power (dBi)	Directional Gain for PSD (dBi)	Power Limit (dBm)	PSD Limit (dBm/1MHz)
Mid	5290	83.40	2.60	5.58	24.00	11.00

Duty Cycle CF (dB)	0.85	Included in Calculations of Corr'd PSD
--------------------	------	--

#### Output Power Results

Channel	Frequency (MHz)	Antenna 1 Meas Power (dBm)	Antenna 2 Meas Power (dBm)	Total Corr'd Power (dBm)	Power Limit (dBm)	Power Margin (dB)
Mid	5290	11.01	11.10	14.07	24.00	-9.93

#### PSD Results

Channel	Frequency (MHz)	Antenna 1 Meas PSD (dBm/1MHz)	Antenna 2 Meas PSD (dBm/1MHz)	Total Corr'd PSD (dBm/1MHz)	PSD Limit (dBm/1MHz)	PSD Margin (dB)
Mid	5290	-6.59	-6.63	-2.75	11.00	-13.75

#### MID CHANNEL

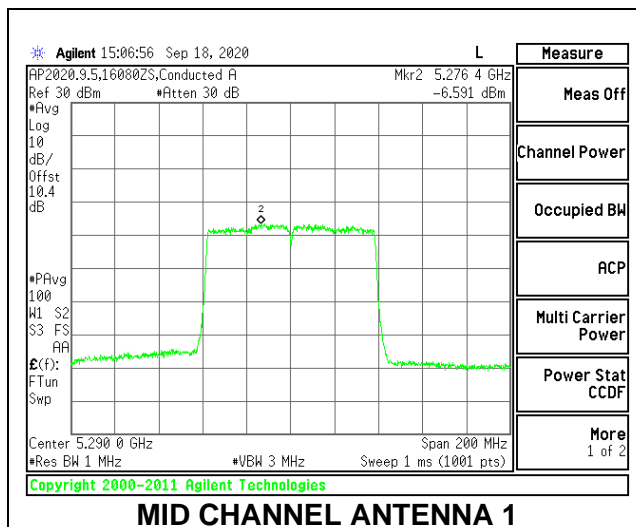

MID CHANNEL ANTENNA 1

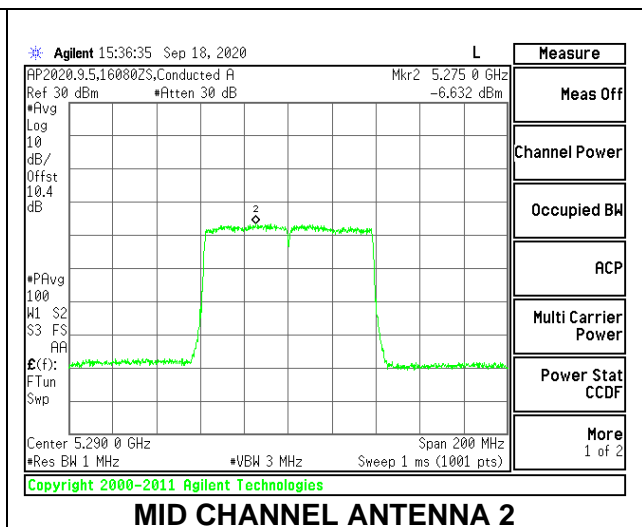

MID CHANNEL ANTENNA 2

### 9.5.7. 802.11n HT20 MODE IN THE 5.6 GHz BAND

#### 2TX Antenna 1 + Antenna 2 CDD MODE (FCC)

Test Engineer:	16080ZS
Test Date:	09/17/2020

#### Bandwidth, Antenna Gain, and Limits

Channel	Frequency (MHz)	Min 26 dB BW (MHz)	Directional Gain for Power (dBi)	Directional Gain for PSD (dBi)	Power Limit (dBm)	PSD Limit (dBm/ 1MHz)
Low	5500	22.00	4.19	7.20	24.00	9.80
Mid	5580	19.30	4.19	7.20	23.86	9.80
High	5700	22.05	4.19	7.20	24.00	9.80
144	5720	15.95	4.19	7.20	23.03	9.80

Duty Cycle CF (dB)	0.22	Included in Calculations of Corr'd PSD
--------------------	------	--

#### Output Power Results

Channel	Frequency (MHz)	Antenna 1 Meas Power (dBm)	Antenna 2 Meas Power (dBm)	Total Corr'd Power (dBm)	Power Limit (dBm)	Power Margin (dB)
Low	5500	15.28	15.55	18.43	24.00	-5.57
Mid	5580	16.00	16.17	19.10	23.86	-4.76
High	5700	14.10	13.97	17.05	24.00	-6.95
144	5720	15.79	16.11	18.96	23.03	-4.06

#### PSD Results

Channel	Frequency (MHz)	Antenna 1 Meas PSD (dBm/ 1MHz)	Antenna 2 Meas PSD (dBm/ 1MHz)	Total Corr'd PSD (dBm/ 1MHz)	PSD Limit (dBm/ 1MHz)	PSD Margin (dB)
Low	5500	3.82	4.15	7.22	9.80	-2.58
Mid	5580	4.91	5.38	8.38	9.80	-1.42
High	5700	1.96	2.45	5.44	9.80	-4.36
144	5720	4.92	5.19	8.28	9.80	-1.52

### LOW CHANNEL

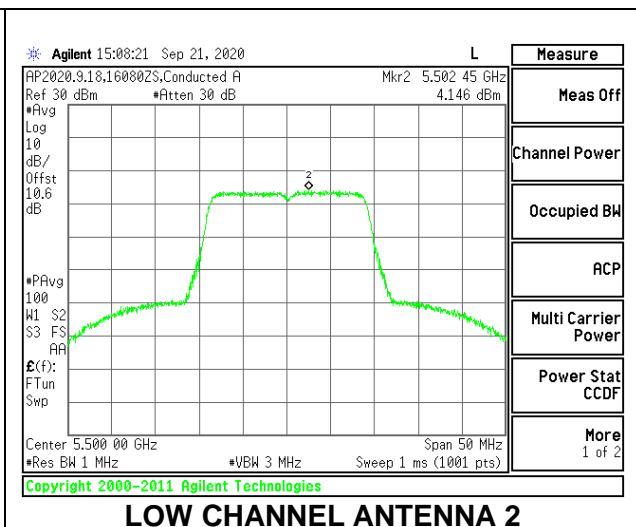
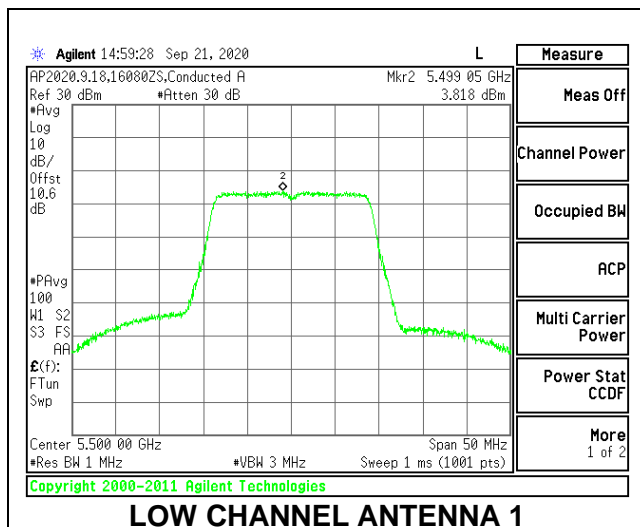

### MID CHANNEL

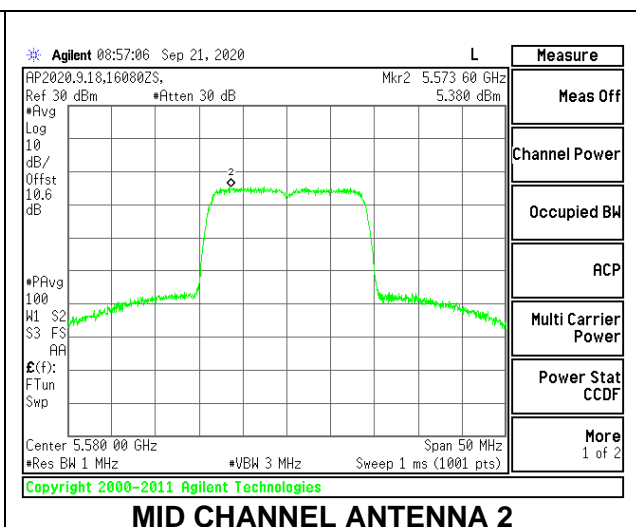
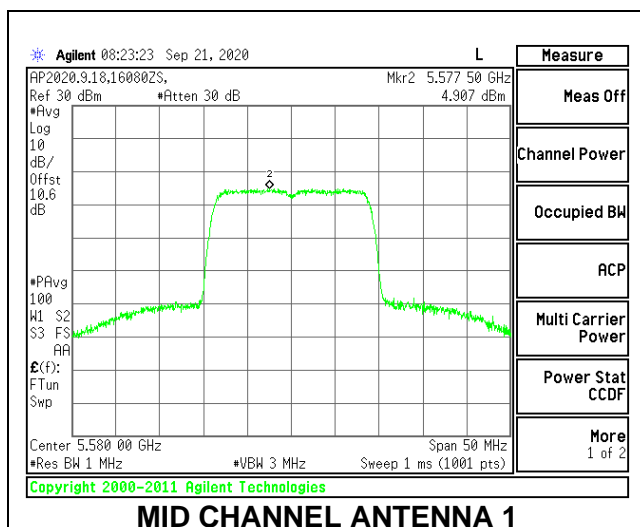



### HIGH CHANNEL

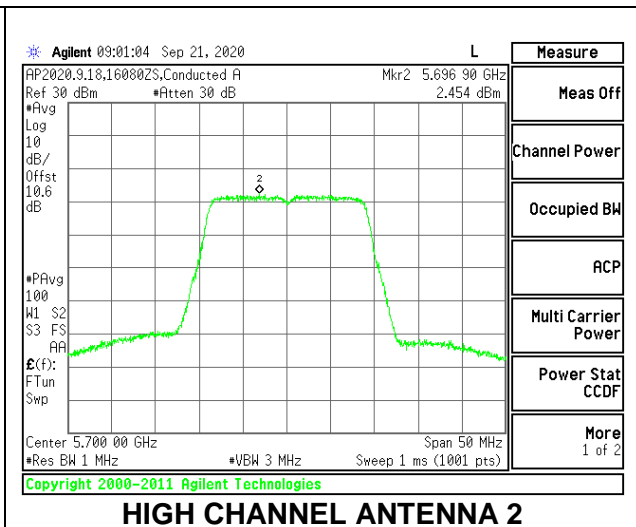
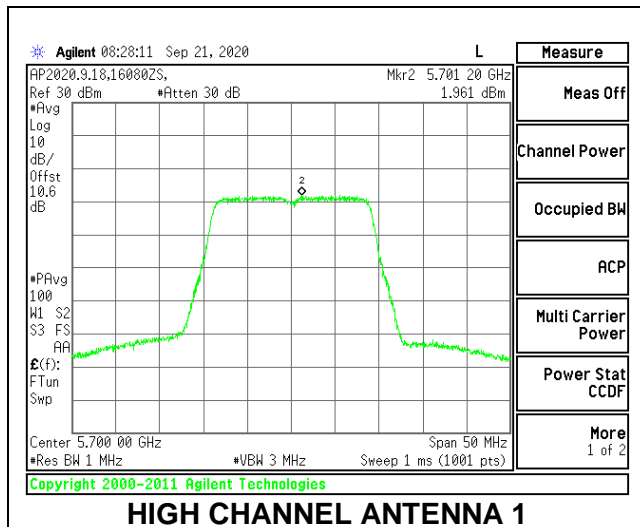

### CHANNEL 144

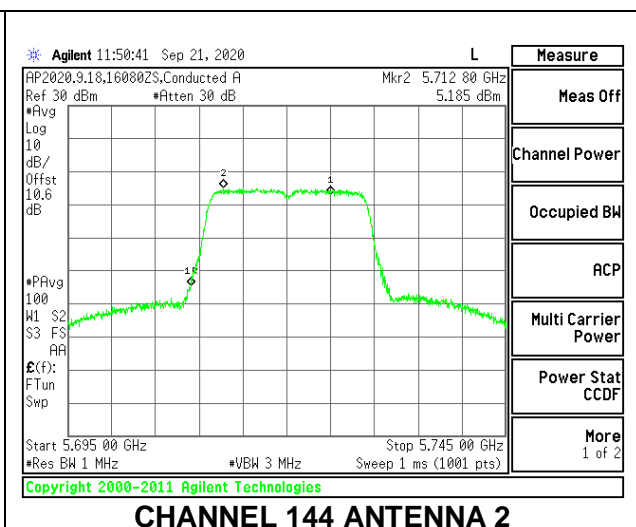
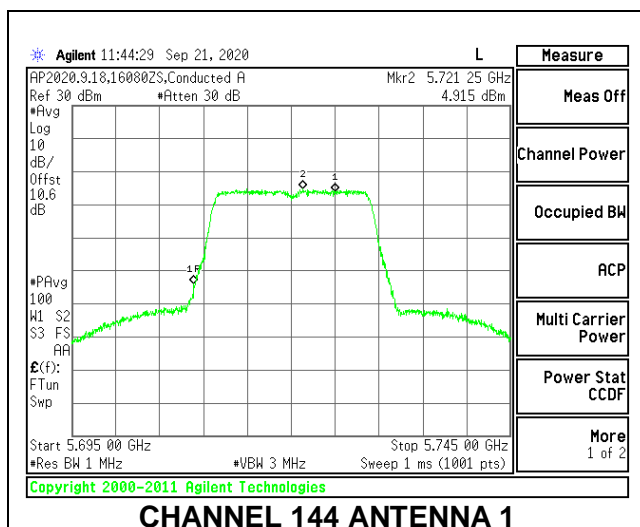

**9.5.8. 802.11n HT40 MODE IN THE 5.6 GHz BAND**

**2TX Antenna 1 + Antenna 2 CDD MODE (FCC)**

<b>Test Engineer:</b>	16080ZS
<b>Test Date:</b>	09/17/2020

**Bandwidth, Antenna Gain, and Limits**

Channel	Frequency (MHz)	Min 26 dB BW (MHz)	Directional Gain for Power (dBi)	Directional Gain for PSD (dBi)	Power Limit (dBm)	PSD Limit (dBm/ 1MHz)
Low	5510	40.70	4.19	7.20	24.00	9.80
Mid	5550	40.90	4.19	7.20	24.00	9.80
High	5670	40.80	4.19	7.20	24.00	9.80
142	5710	35.40	4.19	7.20	24.00	9.80

<b>Duty Cycle CF (dB)</b>	0.44	<b>Included in Calculations of Corr'd PSD</b>
---------------------------	------	---

**Output Power Results**

Channel	Frequency (MHz)	Antenna 1 Meas Power (dBm)	Antenna 2 Meas Power (dBm)	Total Corr'd Power (dBm)	Power Limit (dBm)	Power Margin (dB)
Low	5510	10.75	9.38	13.13	24.00	-10.87
Mid	5550	16.32	16.35	19.35	24.00	-4.65
High	5670	15.17	15.67	18.44	24.00	-5.56
142	5710	15.95	16.45	19.22	24.00	-4.78

**PSD Results**

Channel	Frequency (MHz)	Antenna 1 Meas PSD (dBm/ 1MHz)	Antenna 2 Meas PSD (dBm/ 1MHz)	Total Corr'd PSD (dBm/ 1MHz)	PSD Limit (dBm/ 1MHz)	PSD Margin (dB)
Low	5510	-3.82	-3.07	0.02	9.80	-9.78
Mid	5550	2.41	2.63	5.97	9.80	-3.83
High	5670	1.39	1.50	4.90	9.80	-4.90
142	5710	2.25	2.31	5.73	9.80	-4.07

### LOW CHANNEL

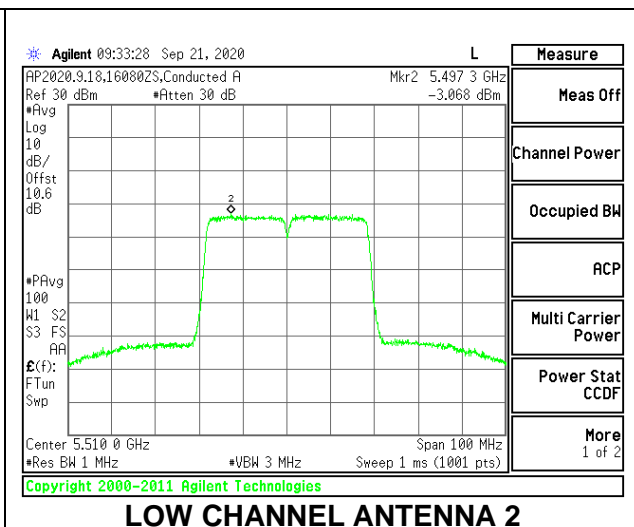
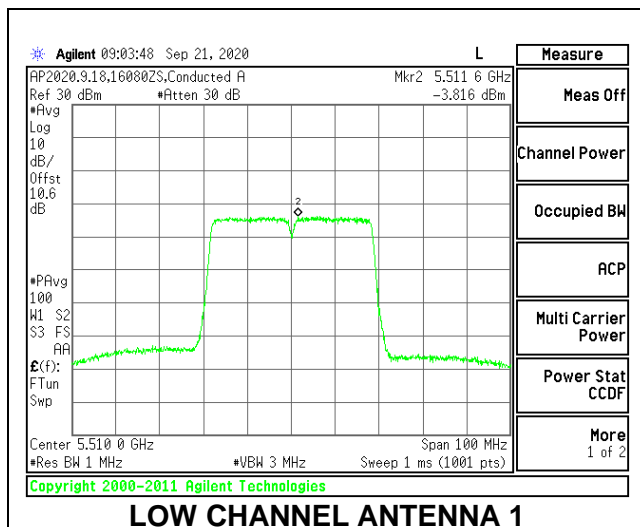

### MID CHANNEL

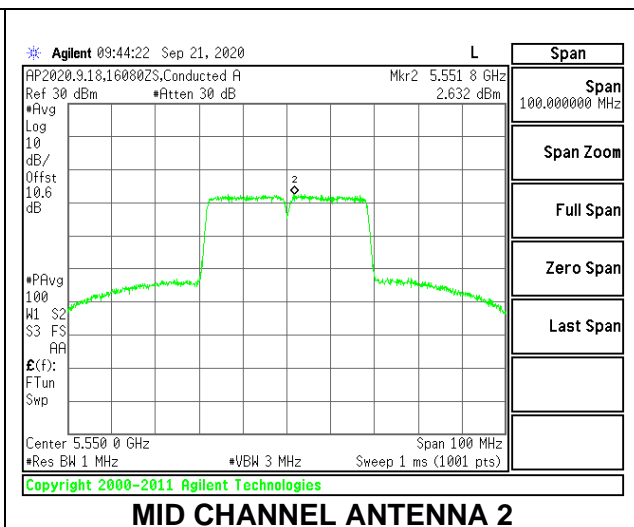
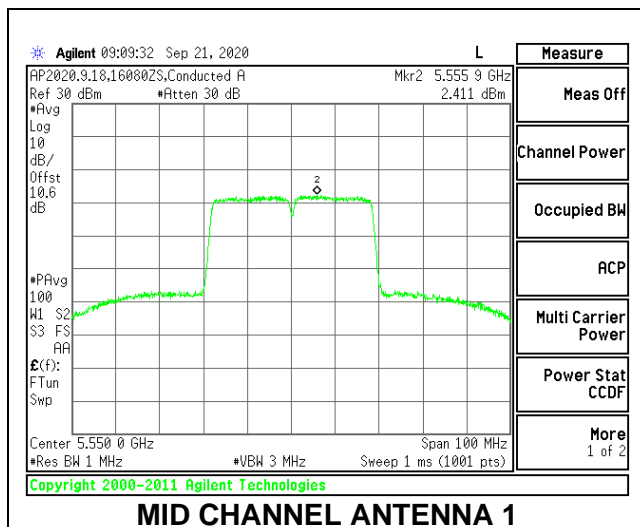

### HIGH CHANNEL

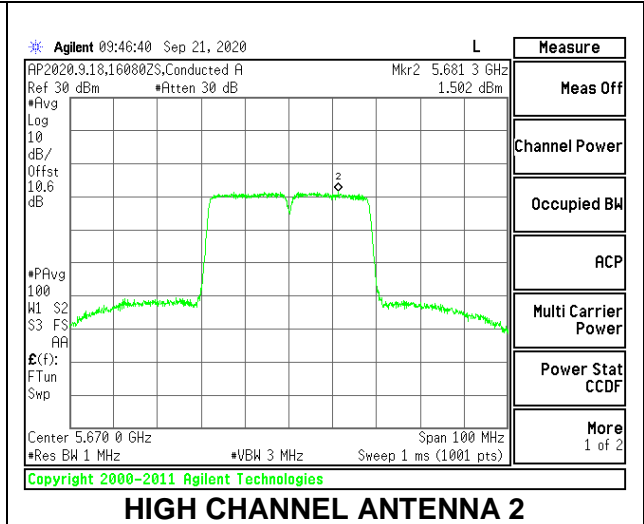
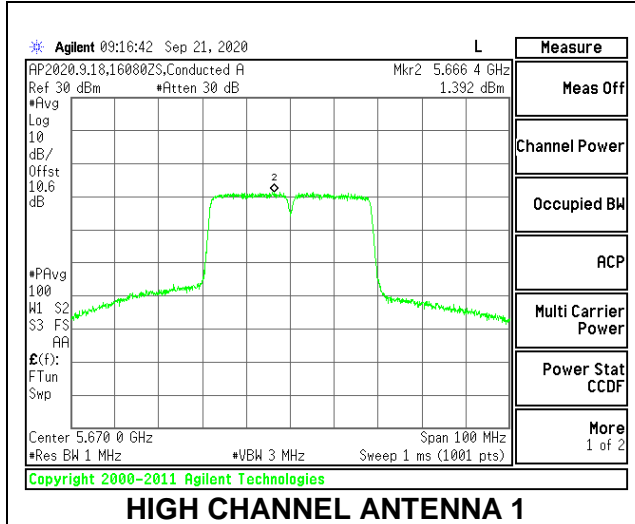

### CHANNEL 142

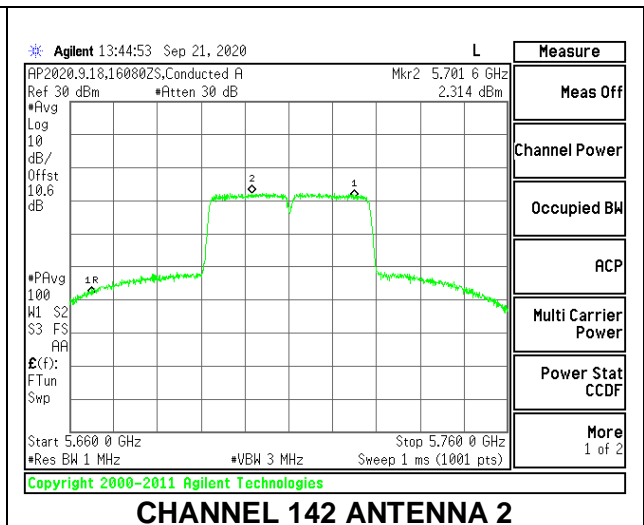
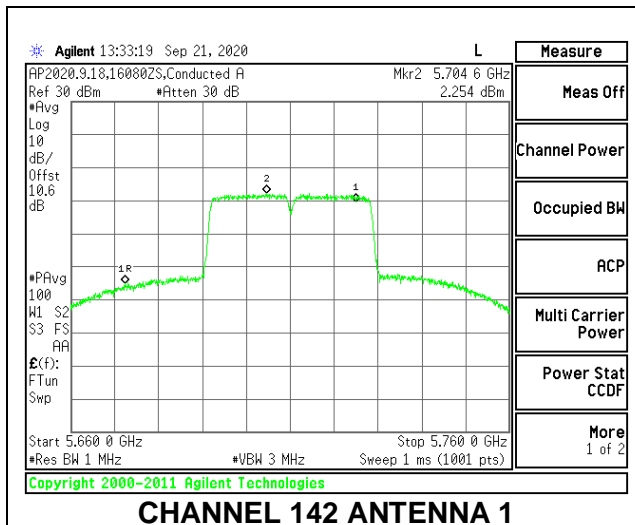

**9.5.9. 802.11ac VHT80 MODE IN THE 5.6 GHz BAND**

**2TX Antenna 1 + Antenna 2 CDD MODE (FCC)**

<b>Test Engineer:</b>	16080ZS
<b>Test Date:</b>	09/17/2020

**Bandwidth, Antenna Gain, and Limits**

Channel	Frequency (MHz)	Min 26 dB BW (MHz)	Directional Gain for Power (dBi)	Directional Gain for PSD (dBi)	Power Limit (dBm)	PSD Limit (dBm/ 1MHz)
Low	5530	83.40	4.19	7.20	24.00	9.80
High	5610	84.00	4.19	7.20	24.00	9.80
138	5690	76.70	4.19	7.20	24.00	9.80

<b>Duty Cycle CF (dB)</b>	0.85	<b>Included in Calculations of Corr'd PSD</b>
---------------------------	------	---

**Output Power Results**

Channel	Frequency (MHz)	Antenna 1 Meas Power (dBm)	Antenna 2 Meas Power (dBm)	Total Corr'd Power (dBm)	Power Limit (dBm)	Power Margin (dB)
Low	5530	11.90	12.39	15.16	24.00	-8.84
High	5610	15.72	16.22	18.99	24.00	-5.01
138	5690	15.55	16.13	18.86	24.00	-5.14

**PSD Results**

Channel	Frequency (MHz)	Antenna 1 Meas PSD (dBm/ 1MHz)	Antenna 2 Meas PSD (dBm/ 1MHz)	Total Corr'd PSD (dBm/ 1MHz)	PSD Limit (dBm/ 1MHz)	PSD Margin (dB)
Low	5530	-5.80	-5.17	-1.62	9.80	-11.42
High	5610	-1.54	-1.30	2.44	9.80	-7.36
138	5690	-1.44	-1.46	2.41	9.80	-7.39

### LOW CHANNEL

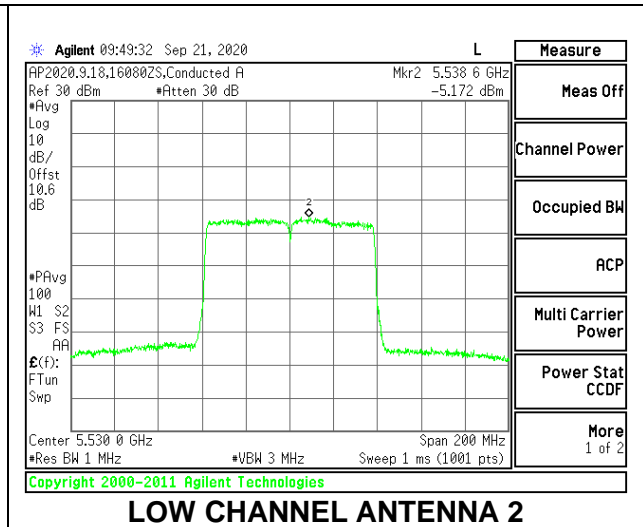
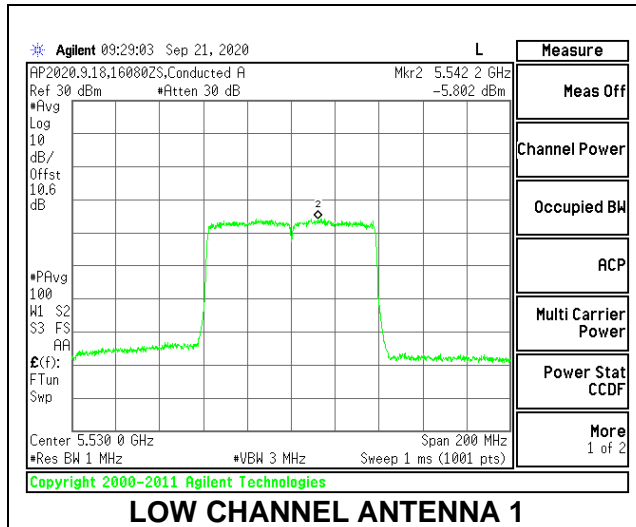

### HIGH CHANNEL

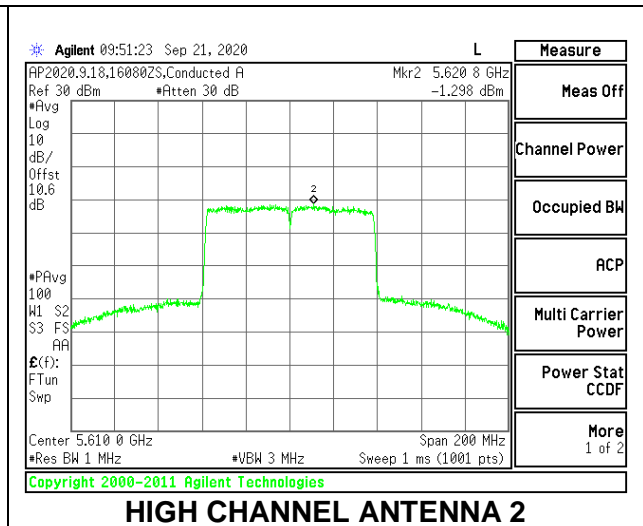
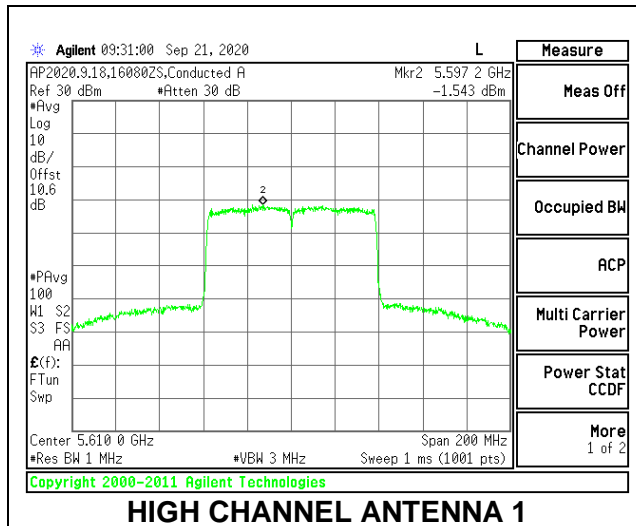

### CHANNEL 138

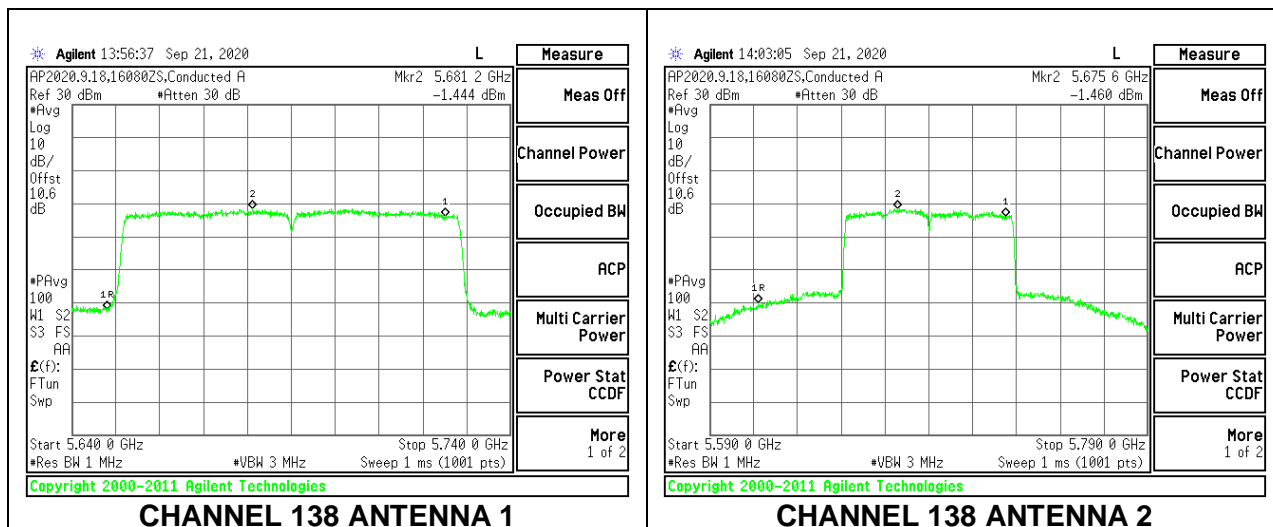

**9.5.10. 802.11n HT20 MODE IN THE 5.8 GHz BAND**

**2TX Antenna 1 + Antenna 2 CDD MODE (FCC)**

<b>Test Engineer:</b>	16080ZS
<b>Test Date:</b>	09/17/2020

**Antenna Gain and Limit**

Channel	Frequency (MHz)	Directional Gain For Power (dBi)	Directional Gain For PSD (dBi)	Power Limit (dBm)	PSD Limit (dBm/ 500KHz)
Low	5745	4.40	7.39	30.00	28.61
Mid	5785	4.40	7.39	30.00	28.61
High	5825	4.40	7.39	30.00	28.61

<b>Duty Cycle CF (dB)</b>	0.22	<b>Included in Calculations of Corr'd PSD</b>
---------------------------	------	---

**Output Power Results**

Channel	Frequency (MHz)	Antenna 1 Meas Power (dBm)	Antenna 2 Meas Power (dBm)	Total Corr'd Power (dBm)	Power Limit (dBm)	Power Margin (dB)
Low	5745	15.64	16.09	18.88	30.00	-11.12
Mid	5785	15.33	16.02	18.70	30.00	-11.30
High	5825	15.37	16.03	18.72	30.00	-11.28

**PSD Results**

Channel	Frequency (MHz)	Antenna 1 Meas PSD (dBm/ 500KHz)	Antenna 2 Meas PSD (dBm/ 500KHz)	Total Corr'd PSD (dBm/ 500KHz)	PSD Limit (dBm/ 500KHz)	PSD Margin (dB)
Low	5745	1.04	2.34	4.97	28.61	-23.64
Mid	5785	0.84	2.09	4.74	28.61	-23.87
High	5825	0.98	2.29	4.92	28.61	-23.69



### LOW CHANNEL

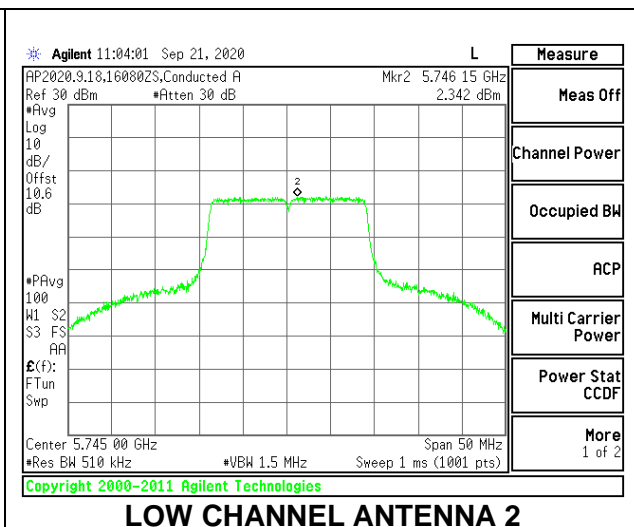
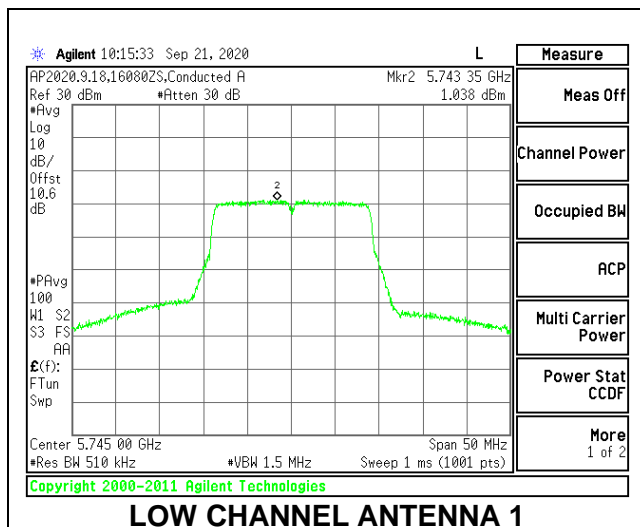

### MID CHANNEL

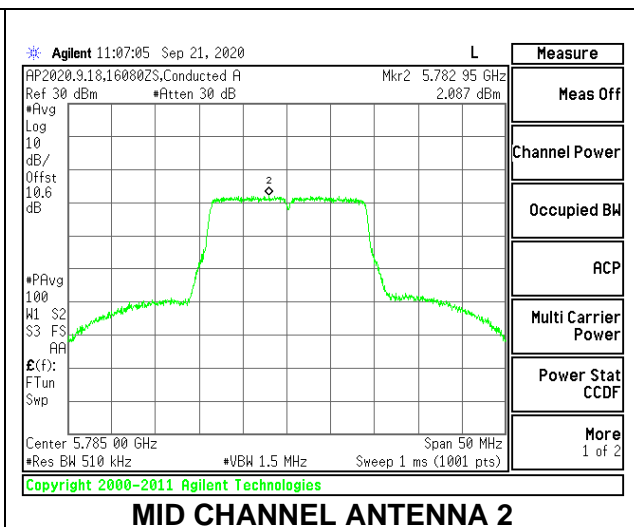
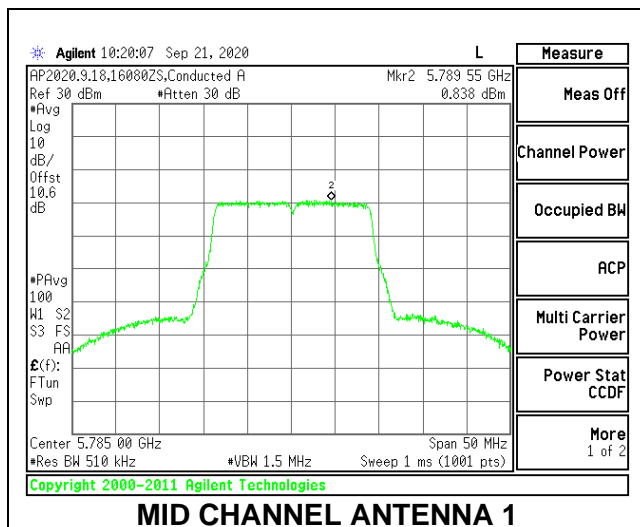

### HIGH CHANNEL

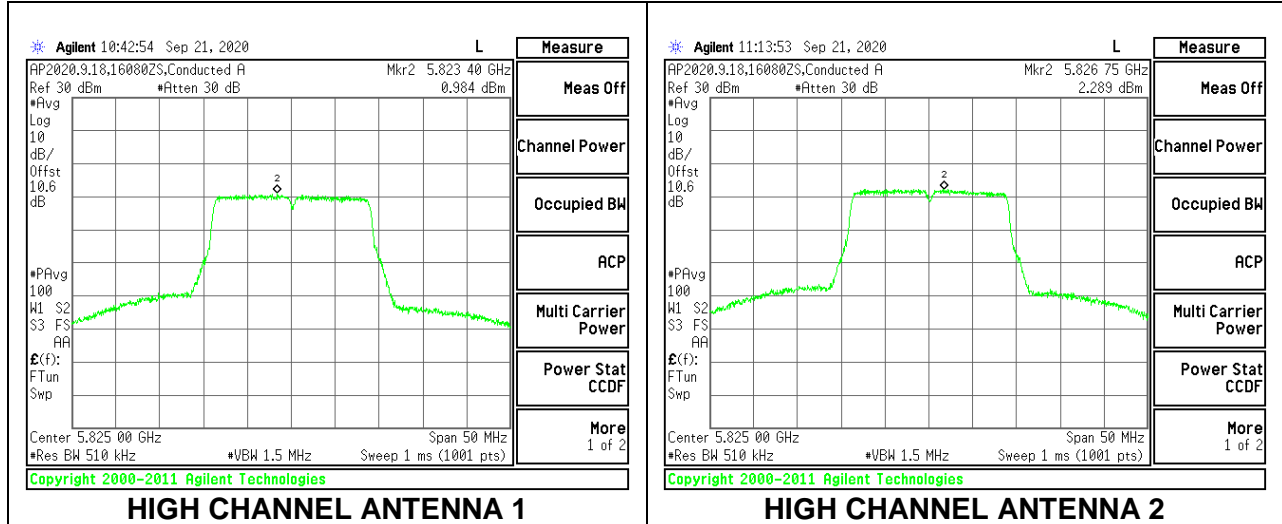

**9.5.11. 802.11n HT40 MODE IN THE 5.8 GHz BAND**

**2TX Antenna 1 + Antenna 2 CDD MODE (FCC)**

<b>Test Engineer:</b>	16080ZS
<b>Test Date:</b>	09/17/2020

**Antenna Gain and Limit**

Channel	Frequency (MHz)	Directional Gain For Power (dBi)	Directional Gain For PSD (dBi)	Power Limit (dBm)	PSD Limit (dBm/ 500KHz)
Low	5755	4.40	7.39	30.00	28.61
High	5795	4.40	7.39	30.00	28.61

<b>Duty Cycle CF (dB)</b>	0.44	<b>Included in Calculations of Corr'd PSD</b>
---------------------------	------	---

**Output Power Results**

Channel	Frequency (MHz)	Antenna 1 Meas Power (dBm)	Antenna 2 Meas Power (dBm)	Total Corr'd Power (dBm)	Power Limit (dBm)	Power Margin (dB)
Low	5755	16.08	16.41	19.26	30.00	-10.74
High	5795	16.03	16.75	19.42	30.00	-10.58

**PSD Results**

Channel	Frequency (MHz)	Antenna 1 Meas PSD (dBm/ 500KHz)	Antenna 2 Meas PSD (dBm/ 500KHz)	Total Corr'd PSD (dBm/ 500KHz)	PSD Limit (dBm/ 500KHz)	PSD Margin (dB)
Low	5755	-0.80	-0.03	3.05	28.61	-25.56
High	5795	-1.23	-0.44	2.63	28.61	-25.98

### LOW CHANNEL

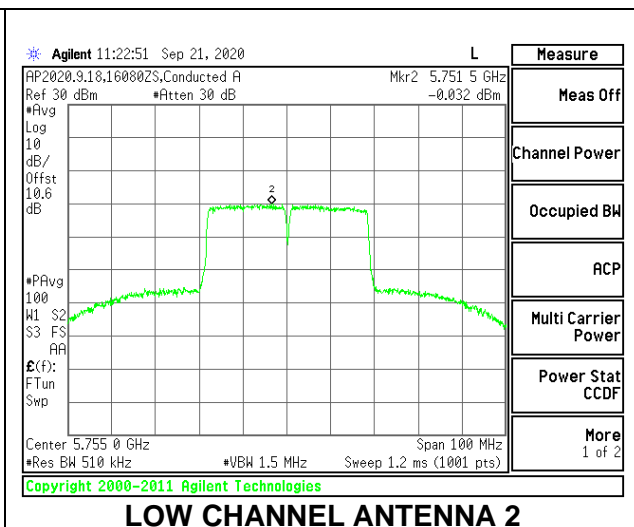
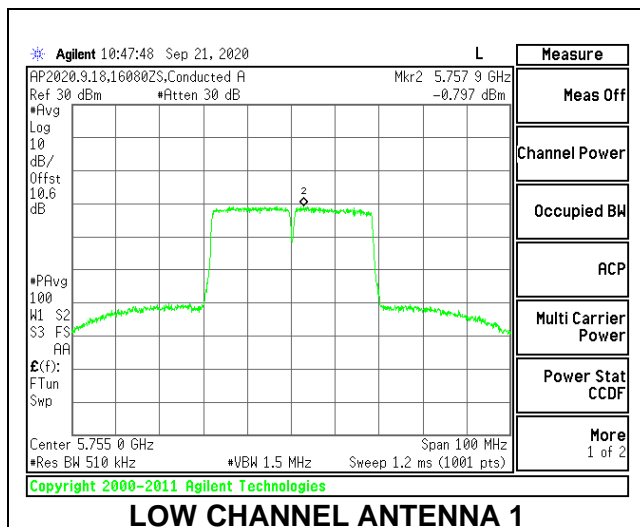

### HIGH CHANNEL

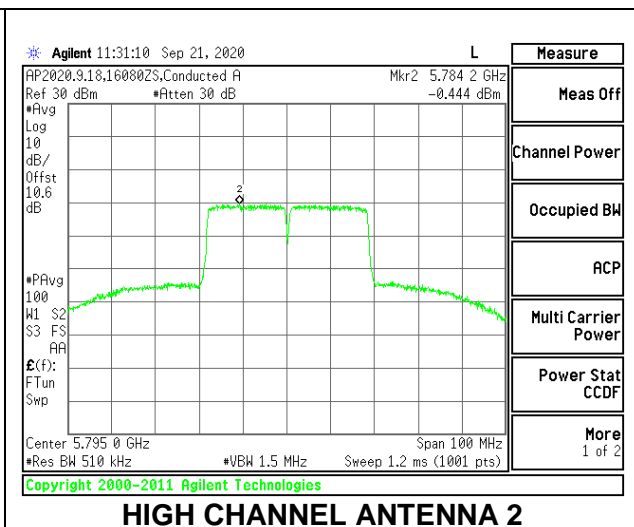
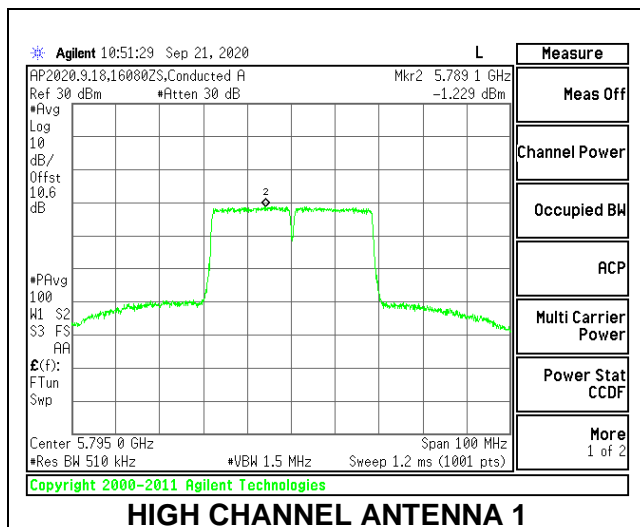

### 9.5.12. 802.11ac VHT80 MODE IN THE 5.8 GHz BAND

#### 2TX Antenna 1 + Antenna 2 CDD MODE (FCC)

Test Engineer:	16080ZS
Test Date:	09/17/2020

#### Antenna Gain and Limit

Channel	Frequency (MHz)	Directional Gain For Power (dBi)	Directional Gain For PSD (dBi)	Power Limit (dBm)	PSD Limit (dBm/500KHz)
Mid	5755	4.40	7.39	30.00	28.61

Duty Cycle CF (dB)	0.85	Included in Calculations of Corr'd PSD
--------------------	------	--

#### Output Power Results

Channel	Frequency (MHz)	Antenna 1 Meas Power (dBm)	Antenna 2 Meas Power (dBm)	Total Corr'd Power (dBm)	Power Limit (dBm)	Power Margin (dB)
Mid	5755	12.43	13.07	15.77	30.00	-14.23

#### PSD Results

Channel	Frequency (MHz)	Antenna 1 Meas PSD (dBm/500KHz)	Antenna 2 Meas PSD (dBm/500KHz)	Total Corr'd PSD (dBm/500KHz)	PSD Limit (dBm/500KHz)	PSD Margin (dB)
Mid	5775	-7.88	-7.34	-3.74	28.61	-32.35

#### MID CHANNEL

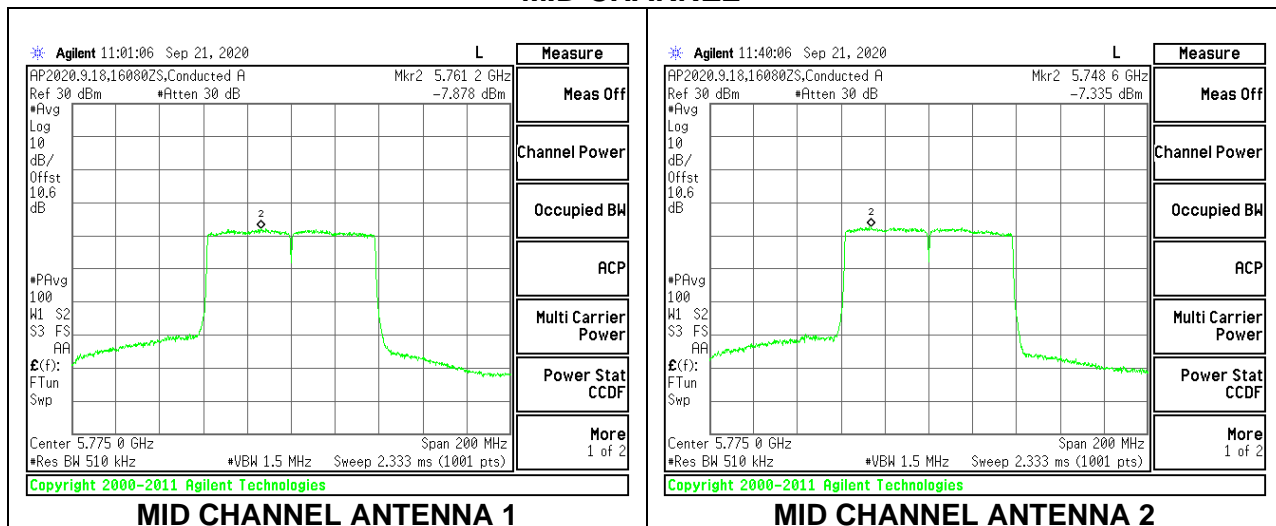

## 10. RADIATED TEST RESULTS

### LIMITS

FCC §15.205 and §15.209 -Restricted bands

FCC §15.407(b)(1-3) -Un-Restricted bands

Frequency Range (MHz)	Field Strength Limit (uV/m) at 3 m	Field Strength Limit (dBuV/m) at 3 m
30 - 88	100	40
88 - 216	150	43.5
216 - 960	200	46
Above 960	500	54

### TEST PROCEDURE

The EUT is placed on a non-conducting table 80 cm above the ground plane for measurement below 1GHz; 1.5 m above the ground plane for measurement above 1GHz. The antenna to EUT distance is 3 meters. The EUT is configured in accordance with ANSI C63.10. The EUT is set to transmit in a continuous mode.

For measurements below 1 GHz the resolution bandwidth is set to 100 kHz for peak detection measurements or 120 kHz for quasi-peak detection measurements. Peak detection is used unless otherwise noted as quasi-peak.

For pre-scans above 1 GHz the resolution bandwidth is set to 1 MHz; the video bandwidth is set to 30 KHz for peak measurements.

For final measurements above 1 GHz the resolution bandwidth is set to 1 MHz; the video bandwidth is set to 3 MHz for peak measurements and as applicable for average measurements.

The spectrum from 30 MHz to 1GHz and 18GHz to 40 GHz is investigated with the transmitter set to transmit at the channel with highest output power as worst-case scenario. 1GHz to 18GHz was set to the lowest, middle, and highest channels in the 5 GHz bands.

The frequency range of interest is monitored at a fixed antenna height and EUT azimuth. The EUT is rotated through 360 degrees to maximize emissions received. The antenna is scanned from 1 to 4 meters above the ground plane to further maximize the emission. Measurements are made with the antenna polarized in both the vertical and the horizontal positions.

2D antenna use - For below 30MHz testing, investigation was done on three antenna orientations (parallel, perpendicular, and ground-parallel), parallel and perpendicular are the worst orientations, therefore testing was performed on these two orientations only.

---

**KDB 414788 Open Field Site(OFS) and Chamber Correlation Justification**

Base on FCC 15.31 (f) (2): measurements may be performed at a distance closer than that specified in the regulations; however, an attempt should be made to avoid making measurements in the near field.

OFS and chamber correlation testing had been performed and chamber measured test result is the worst case test result.

## 10.1. TRANSMITTER ABOVE 1 GHz

### 10.1.1. TX ABOVE 1 GHz 802.11n HT20 MODE IN THE 5.2 GHz BAND

#### 2TX Antenna 1 + Antenna 2 CDD MODE

#### BANDEDGE (LOW CHANNEL)

#### HORIZONTAL RESULT

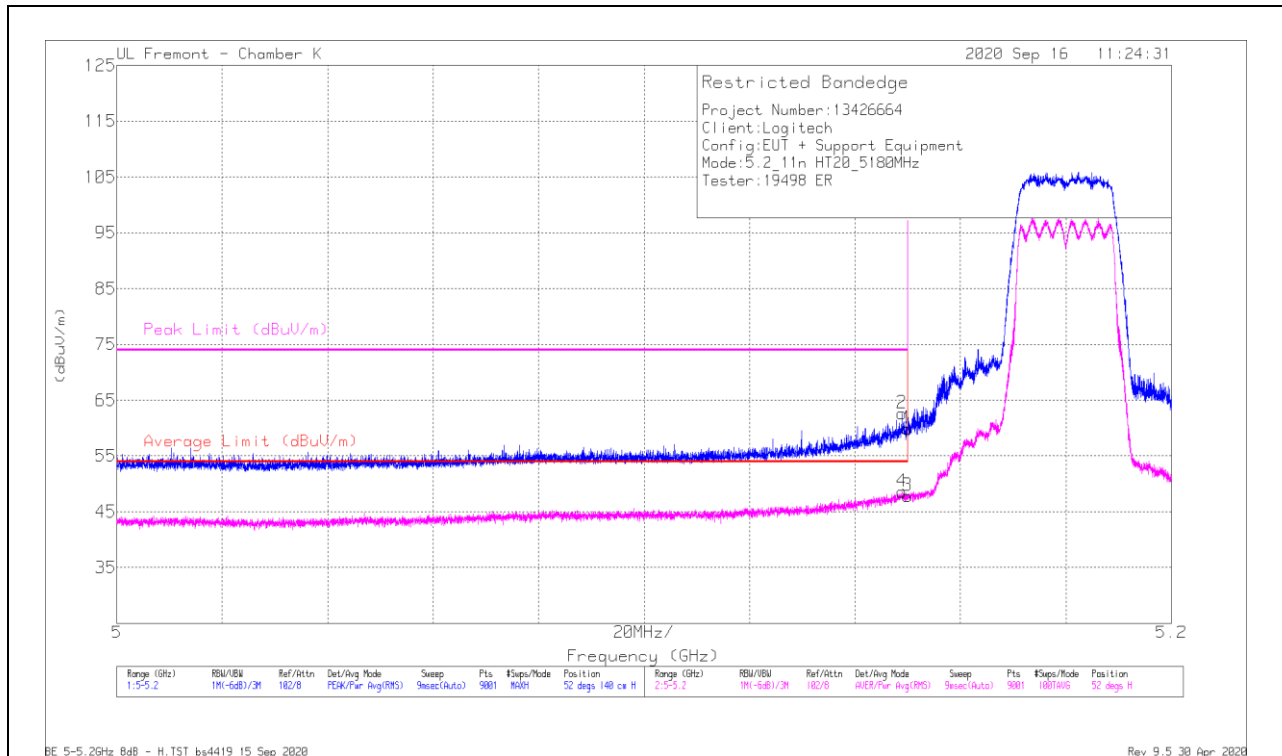

Marker	Frequency (GHz)	Meter Reading (dBuV)	Det	AF T863 (dBm)	Ampr/Cbl/Ftr/Pad (dB)	DC Corr (dB)	Corrected Reading (dBuV)	Average Limit (dBuV/m)	Margin (dB)	Peak Limit (dBuV/m)	PK Margin (dB)	Azimuth (Degs)	Height (cm)	Polarity
1	* 5.15	32.96	Pk	34.6	-7.6	0	59.96	-	-	74	-14.04	52	140	H
2	* 5.14891	35.79	Pk	34.5	-7.6	0	62.69	-	-	74	-11.31	52	140	H
3	* 5.15	20.58	RMS	34.6	-7.6	22	47.61	54	-6.19	-	-	52	140	H
4	* 5.14884	21.47	RMS	34.5	-7.6	22	48.6	54	-5.4	-	-	52	140	H

\* - indicates frequency in CFR47 Pt 15 / IC RSS-Restricted Band

Pk - Peak detector

RMS - RMS detection



### VERTICAL RESULT

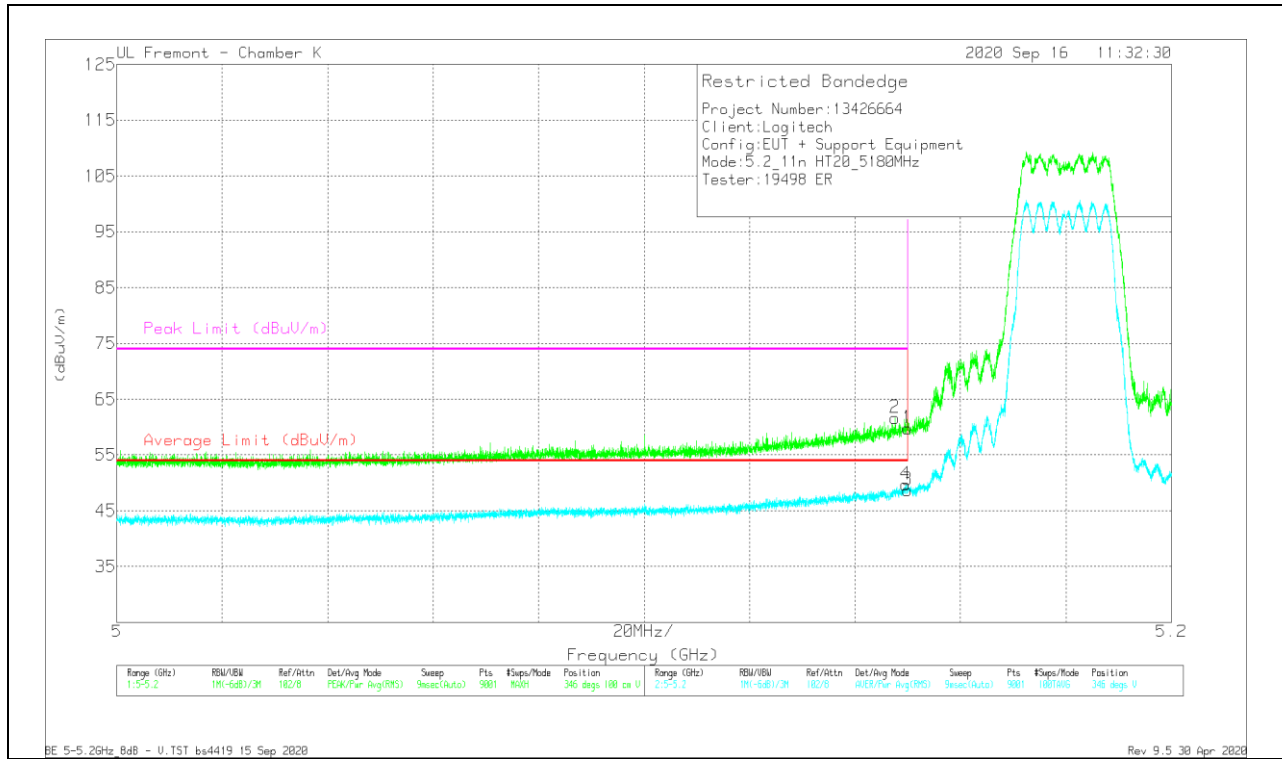

Marker	Frequency (GHz)	Meter Reading (dBuV)	Det	AF T963 (dBm)	Amp/Col/Filt/Pad (dB)	DC Corr (dB)	Corrected Reading (dBuV/m)	Average Limit (dBuV/m)	Margin (dB)	Peak Limit (dBuV/m)	PK Margin (dB)	Azimuth (Degs)	Height (cm)	Polarity
1	* 5.15	32.83	Pk	34.6	-7.6	0	39.83	-	-	74	-14.17	346	100	V
2	* 5.14784	34.78	Pk	34.5	-7.6	0	61.68	-	-	74	-12.32	346	100	V
3	* 5.15	21.46	RMS	34.6	-7.6	22	48.69	54	-5.31	-	-	346	100	V
4	* 5.1496	22.43	RMS	34.6	-7.6	22	49.66	54	-4.34	-	-	346	100	V

\* - indicates frequency in CFR47 Pt 15 / IC RSS-Restricted Band  
 Pk - Peak detector  
 RMS - RMS detection

**HARMONICS AND SPURIOUS EMISSIONS**

**LOW CHANNEL RESULTS**

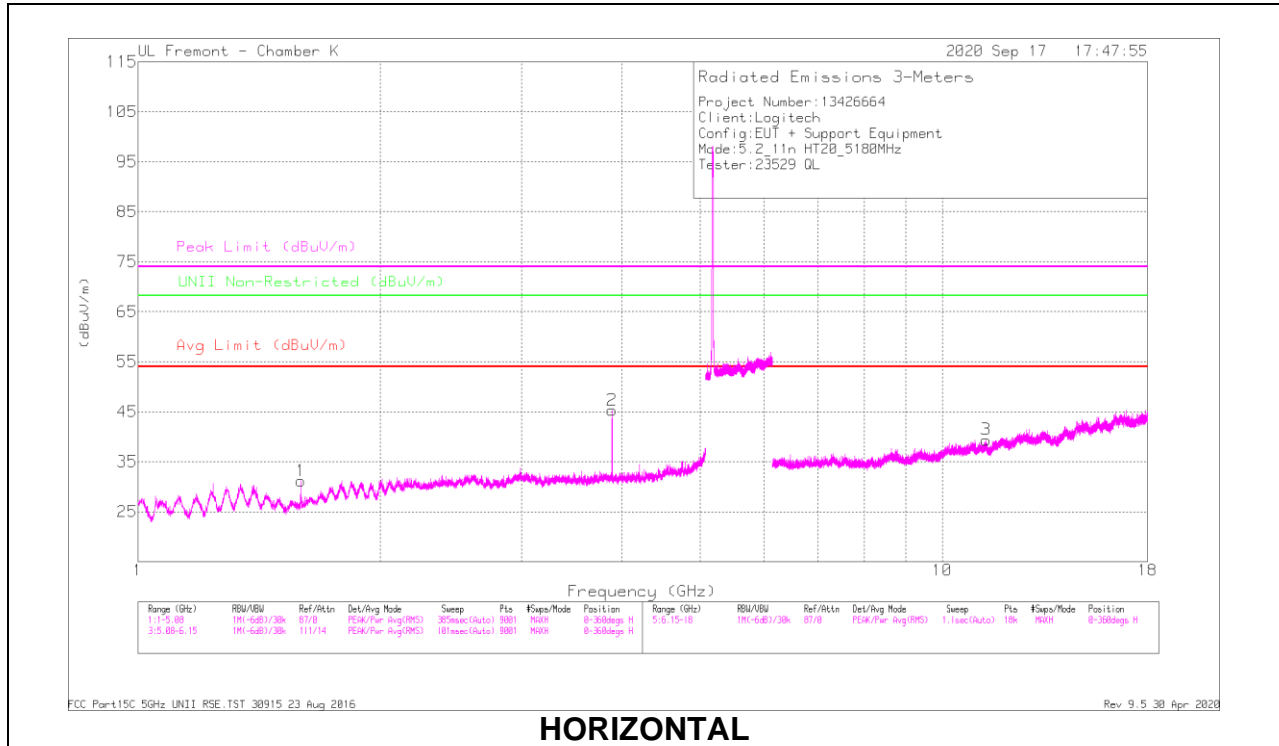

**HORIZONTAL**

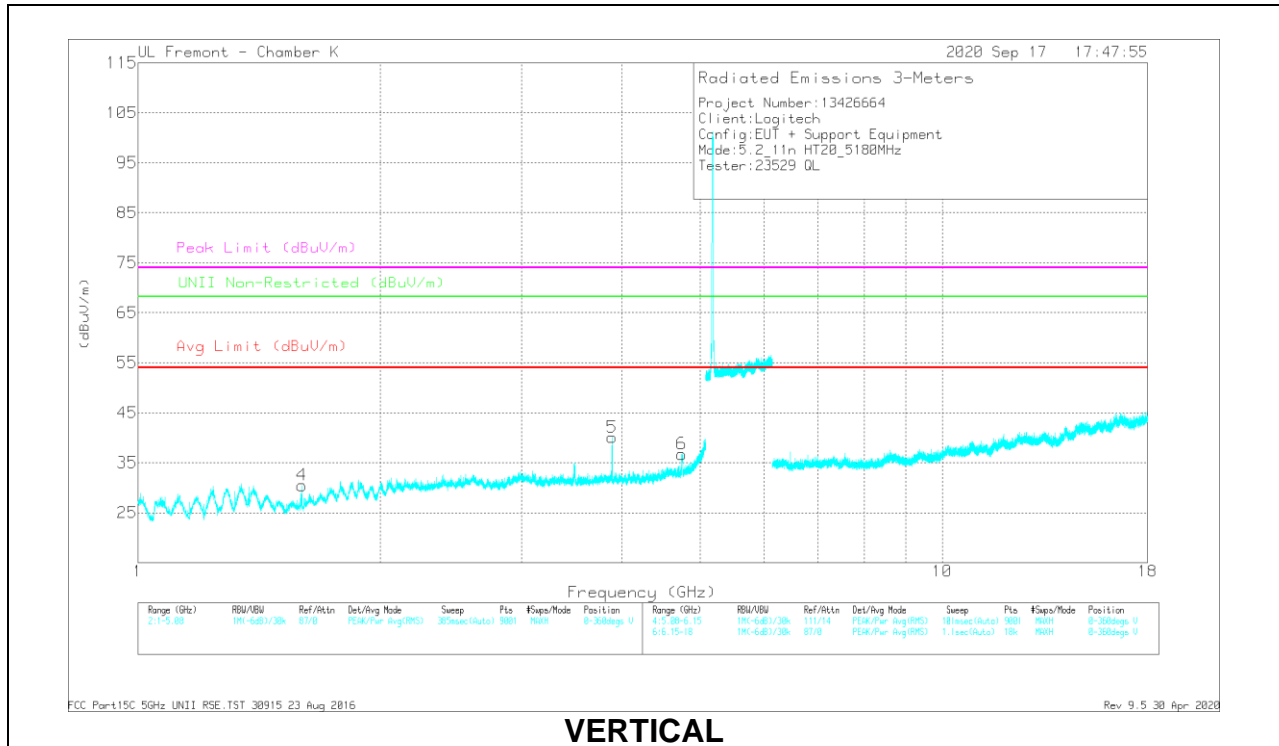

**VERTICAL**

**RADIATED EMISSIONS**

Marker	Frequency (MHz)	Meas Reading (dBuV)	Det	AF 1513 (dBm)	AmpCofFmPad (dB)	DC Corr (dB)	Corrected Reading (dBuV/m)	Avg Limit (dBuV/m)	Margin (dB)	Peak Limit (dBuV/m)	PK Margin (dB)	UNE Non-Restricted (dBuV/m)	PK Margin (dB)	Altitude (Feet)	Height (m)	Polarity
1	* 1.59493	67.71	PK-U	28.1	-46.2	0	49.61	-	-	74	-24.39	-	-	97	279	H
	* 1.59392	46.89	ADR	28.1	-46.2	.22	29.02	54	-24.98	-	-	-	-	97	279	H
2	* 3.88496	55.48	PK-U	33.6	-41.8	0	47.28	-	-	74	-26.72	-	-	45	204	H
	* 3.88502	52.88	ADR	33.6	-41.8	.22	44.91	54	-9.09	-	-	-	-	45	204	H
4	* 1.59576	58.51	PK-U	28.1	-45.2	0	48.41	-	-	74	-25.59	-	-	281	113	V
	* 1.59896	46.94	ADR	28.1	-46.2	.22	29.07	54	-24.93	-	-	-	-	281	113	V
5	* 3.88502	52.99	PK-U	33.6	-41.8	0	44.79	-	-	74	-29.21	-	-	329	146	V
	* 3.88502	48.72	ADR	33.6	-41.8	.22	40.75	54	-13.25	-	-	-	-	329	146	V
6	* 4.74399	53.3	PK-U	34.3	-40.9	0	47.2	-	-	74	-26.8	-	-	58	96	V
	* 4.75021	42.89	ADR	34.2	-40.8	.22	36.52	54	-17.48	-	-	-	-	58	96	V
3	* 11.33539	44.91	PK-U	38	-36.1	0	46.81	-	-	74	-27.19	-	-	55	127	H
	* 11.33272	33.29	ADR	38	-36.2	.22	35.32	54	-18.68	-	-	-	-	55	127	H

\* - indicates frequency in CFR47 Pt 15 / IC RSS-Restricted Band  
 PK-U - U-NII: Maximum Peak  
 ADR - U-NII AD primary method, RMS average

### MID CHANNEL RESULTS

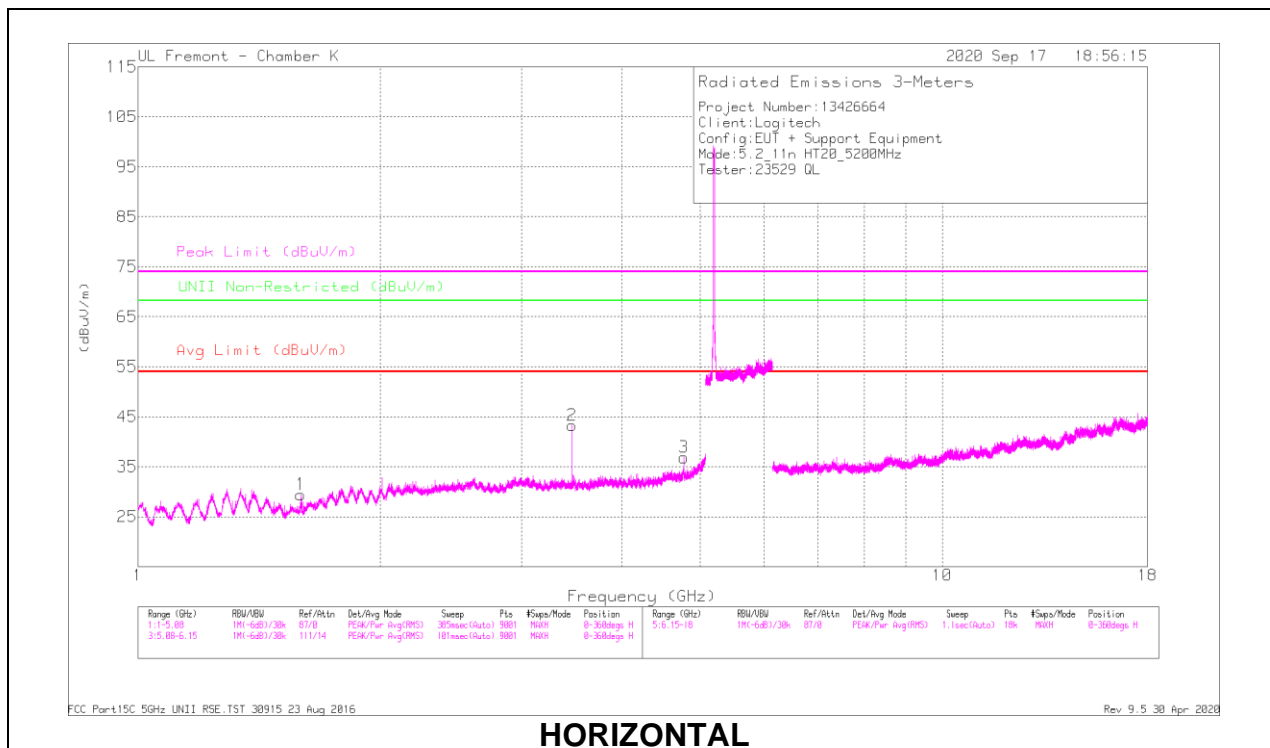

### HORIZONTAL

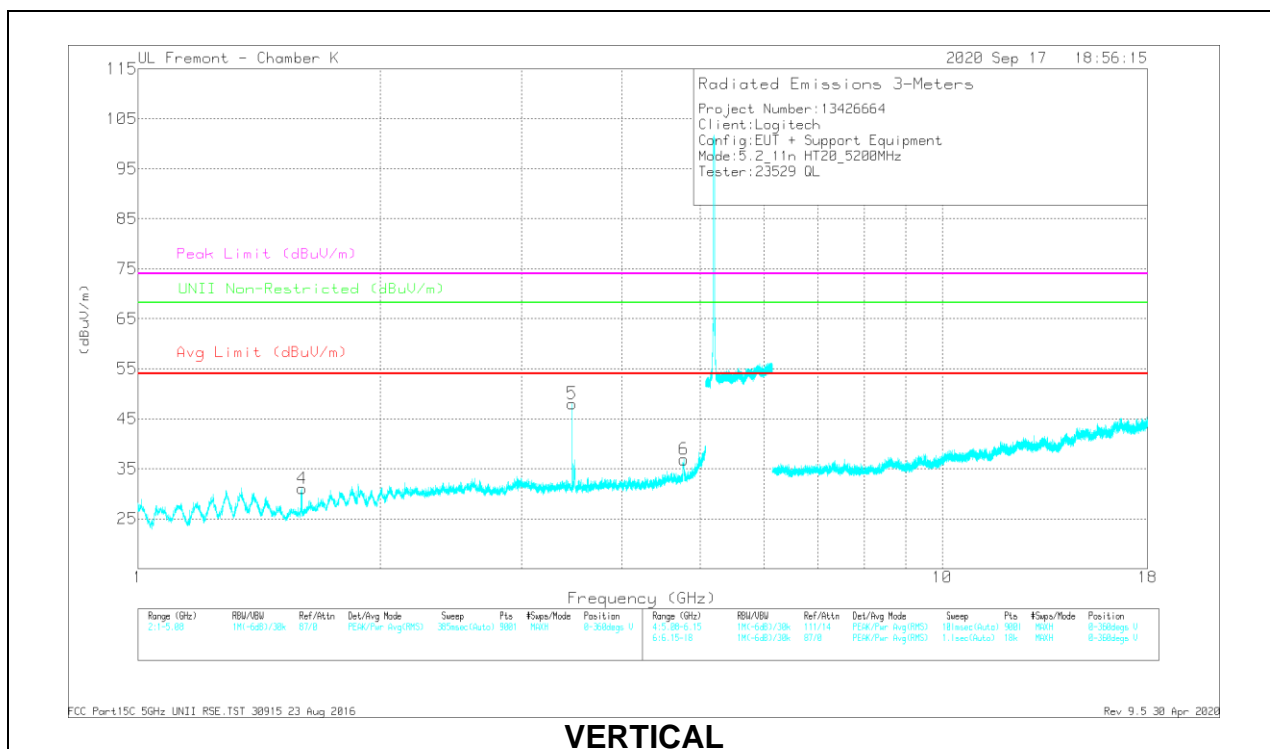

### VERTICAL