

FCC Test Report (WLAN-15.247)

Report No.: RF141203E08A

FCC ID: JNZVR0004

Test Model: V-R0004

Received Date: Dec. 03, 2014

Test Date: Jan. 20 to 27, 2015

Issued Date: Jan. 30, 2015

Applicant: LOGITECH FAR EAST LTD.

Address: #2 Creation Rd. 4, Science-Based Ind. Park Hsinchu Taiwan, R.O.C.

Issued By: Bureau Veritas Consumer Products Services (H.K.) Ltd., Taoyuan Branch
Hsin Chu Laboratory

Lab Address: No. 81-1, Lu Liao Keng, 9th Ling, Wu Lung Tsuen, Chiung Lin Hsiang, Hsin
Chu Hsien 307, Taiwan R.O.C.

Test Location (1): No. 81-1, Lu Liao Keng, 9th Ling, Wu Lung Tsuen, Chiung Lin Hsiang, Hsin
Chu Hsien 307, Taiwan R.O.C.

Test Location (2): No. 49, Ln. 206, Wende Rd., Shangshan Tsuen, Chiung Lin Hsiang, Hsin
Chu Hsien 307, Taiwan R.O.C.



This report is for your exclusive use. Any copying or replication of this report to or for any other person or entity, or use of our name or trademark, is permitted only with our prior written permission. This report sets forth our findings solely with respect to the test samples identified herein. The results set forth in this report are not indicative or representative of the quality or characteristics of the lot from which a test sample was taken or any similar or identical product unless specifically and expressly noted. Our report includes all of the tests requested by you and the results thereof based upon the information that you provided to us. You have 60 days from date of issuance of this report to notify us of any material error or omission caused by our negligence, provided, however, that such notice shall be in writing and shall specifically address the issue you wish to raise. A failure to raise such issue within the prescribed time shall constitute your unqualified acceptance of the completeness of this report, the tests conducted and the correctness of the report contents. Unless specific mention, the uncertainty of measurement has been explicitly taken into account to declare the compliance or non-compliance to the specification. The report must not be used by the client to claim product certification, approval, or endorsement by TAF or any government agencies.

Table of Contents

Release Control Record	4
1 Certificate of Conformity	5
2 Summary of Test Results	6
2.1 Measurement Uncertainty.....	6
2.2 Modification Record.....	6
3 General Information	7
3.1 General Description of EUT (WLAN).....	7
3.2 Description of Test Modes.....	9
3.2.1 Test Mode Applicability and Tested Channel Detail.....	10
3.3 Duty Cycle of Test Signal.....	12
3.4 Description of Support Units.....	13
3.4.1 Configuration of System under Test.....	14
3.5 General Description of Applied Standards.....	15
4 Test Types and Results	16
4.1 Radiated Emission and Bandedge Measurement.....	16
4.1.1 Limits of Radiated Emission and Bandedge Measurement.....	16
4.1.2 Test Instruments.....	17
4.1.3 Test Procedures.....	19
4.1.4 Deviation from Test Standard.....	19
4.1.5 Test Set Up.....	20
4.1.6 EUT Operating Conditions.....	21
4.1.7 Test Results.....	22
4.2 Conducted Emission Measurement.....	29
4.2.1 Limits of Conducted Emission Measurement.....	29
4.2.2 Test Instruments.....	29
4.2.3 Test Procedures.....	30
4.2.4 Deviation from Test Standard.....	30
4.2.5 Test Setup.....	30
4.2.6 EUT Operating Conditions.....	30
4.2.7 Test Results (Mode 1).....	31
4.2.8 Test Results (Mode 2).....	33
4.3 6dB Bandwidth Measurement.....	35
4.3.1 Limits of 6dB Bandwidth Measurement.....	35
4.3.2 Test Setup.....	35
4.3.3 Test Instruments.....	35
4.3.4 Test Procedure.....	35
4.3.5 Deviation from Test Standard.....	35
4.3.6 EUT Operating Conditions.....	35
4.3.7 Test Result.....	36
4.4 Conducted Output Power Measurement.....	37
4.4.1 Limits of Conducted Output Power Measurement.....	37
4.4.2 Test Setup.....	37
4.4.3 Test Instruments.....	37
4.4.4 Test Procedures.....	37
4.4.5 Deviation from Test Standard.....	37
4.4.6 EUT Operating Conditions.....	37
4.4.7 Test Results.....	38
4.5 Power Spectral Density Measurement.....	39
4.5.1 Limits of Power Spectral Density Measurement.....	39
4.5.2 Test Setup.....	39
4.5.3 Test Instruments.....	39
4.5.4 Test Procedure.....	39
4.5.5 Deviation from Test Standard.....	39



4.5.6 EUT Operating Condition	39
4.5.7 Test Results	40
4.6 Conducted Out of Band Emission Measurement.....	41
4.6.1 Limits of Conducted Out of Band Emission Measurement	41
4.6.2 Test Setup.....	41
4.6.3 Test Instruments	41
4.6.4 Test Procedure	41
4.6.5 Deviation from Test Standard	42
4.6.6 EUT Operating Condition	42
4.6.7 Test Results	42
5 Pictures of Test Arrangements.....	45
Appendix – Information on the Testing Laboratories	46



A D T

Release Control Record

Issue No.	Description	Date Issued
RF141203E08A	Original release.	Jan. 30, 2015

2 Summary of Test Results

For 2.4GHz

47 CFR FCC Part 15, Subpart C (SECTION 15.247)			
FCC Clause	Test Item	Result	Remarks
15.207	AC Power Conducted Emission	PASS	Meet the requirement of limit. Minimum passing margin is -6.60dB at 0.30234MHz.
15.205 / 15.209 / 15.247(d)	Radiated Emissions and Band Edge Measurement	PASS	Meet the requirement of limit. Minimum passing margin is -1.0dB at 2390.00MHz.
15.247(d)	Antenna Port Emission	PASS	Meet the requirement of limit.
15.247(a)(2)	6dB bandwidth	PASS	Meet the requirement of limit.
15.247(b)	Conducted power	PASS	Meet the requirement of limit.
15.247(e)	Power Spectral Density	PASS	Meet the requirement of limit.
15.203	Antenna Requirement	PASS	No antenna connector is used.

NOTE: 1. For WLAN: The EUT was operating in 2400 ~ 2483.5MHz, 5.15~5.25GHz and 5.725~5.850GHz frequencies band. This report was recorded the RF parameters including 2400 ~ 2483.5MHz. For the 5.15~5.25GHz, 5.47~5.725GHz and 5.725~5.850GHz RF parameters was recorded in another test report.

2.1 Measurement Uncertainty

Where relevant, the following measurement uncertainty levels have been estimated for tests performed on the EUT as specified in CISPR 16-4-2:

Measurement	Frequency	Expanded Uncertainty (k=2) (\pm)
Conducted Emissions at mains ports	150kHz ~ 30MHz	2.86 dB
Radiated Emissions up to 1 GHz	30MHz ~ 200MHz	5.37 dB
Radiated Emissions above 1 GHz	1GHz ~ 6GHz	3.72 dB
	6GHz ~ 18GHz	4.00 dB
	18GHz ~ 40GHz	4.11 dB

2.2 Modification Record

There were no modifications required for compliance.

3 General Information

3.1 General Description of EUT (WLAN)

Product	ConferenceCam Connect
Brand	Logitech
Test Model	V-R0004
Status of EUT	ENGINEERING SAMPLE
Power Supply Rating	DC 5V from USB interface or DC 3.6V from battery or DC 12V from power adapter
Modulation Type	64QAM, 16QAM, QPSK, BPSK for OFDM
Modulation Technology	OFDM
Transfer Rate	802.11a/g: up to 54Mbps 802.11n: up to 150Mbps
Operating Frequency	For 15.407 5.18 ~ 5.24GHz, 5.745 ~ 5.825GHz
	For 15.247 2.412 ~ 2.462GHz
Number of Channel	For 15.407 9 for 802.11a, 802.11n (HT20) 4 for 802.11n (HT40)
	For 15.247 11 for 802.11g, 802.11n (HT20)
Output Power	For 15.407 802.11a:206.063 mW 802.11n (HT20): 194.984mW 802.11n (HT40): 112.46 mW
	For 15.247 802.11g: 304.789mW 802.11n (HT20): 278.612mW
Antenna Type	Refer to NOTE
Antenna Connector	Refer to NOTE
Accessory Device	Remote control (Model : R-R0007) x1 Adapter x1
Data Cable Supplied	USB charging cable (shielded, 2m with one core) x 1

Note:

1. There are Bluetooth 4.0, WLAN and NFC (Passive) technology used for the EUT.
2. For WLAN, 2.4GHz and 5GHz technology can not transmit at same time.
3. WLAN and Bluetooth technology can transmit at same time.
4. The emission of the simultaneous operation (WLAN & Bluetooth) has been evaluated and no non-compliance was found.
5. The EUT must be supplied with a battery or a adapter, please refer to the following table:

Battery		
Brand	Model No.	Spec.
SANYO	533-000104	3.6Vdc, 3200 mAh, 11.52 Wh
Adapter		
Brand	Model No.	Spec.
Logitech	DSA-12CA-12 120100	AC Input: 100-240V, 0.3A, 50/60Hz DC Output: 12V, 1A DC output cable(shielded 3m with one core)

6. The EUT was pre-tested under following test modes :

Test Mode	Description
Mode A	Power from Battery
Mode B	Power from Adapter
Mode C	Power from USB interface

For the above modes, the worst radiated test was found in **Mode C**. Therefore only the test data of the modes were recorded in this report.

7. The antennas provided to the EUT, please refer to the following table:

BT					
Brand	Model	Gain (dBi)	Antenna Type	Connector Type	Frequency range (GHz to GHz)
NA	NA	-1.29	PCB printed	NA	2.402 ~ 2.48
WLAN					
Brand	Model	Gain (dBi)	Antenna Type	Connector Type	Frequency range (GHz to GHz)
NA	NA	1.64	PCB printed	NA	2.4 ~ 2.4835
		1.57			5.15 ~ 5.85

8. The EUT incorporates a SISO function.

2.4GHz Band			
MODULATION MODE	DATA RATE (MCS)	TX & RX CONFIGURATION	
802.11g	6 ~ 54Mbps	1TX	1RX
802.11n (HT20)	MCS 0~7	1TX	1RX
5GHz Band			
MODULATION MODE	DATA RATE (MCS)	TX & RX CONFIGURATION	
802.11a	6 ~ 54Mbps	1TX	1RX
802.11n (HT20)	MCS 0~7	1TX	1RX
802.11n (HT40)	MCS 0~7	1TX	1RX

9. The above EUT information is declared by manufacturer and for more detailed features description, please refer to the manufacturer's specifications or user's manual.

3.2 Description of Test Modes

11 channels are provided for 802.11g and 802.11n (HT20):

Channel	Frequency	Channel	Frequency
1	2412MHz	7	2442MHz
2	2417MHz	8	2447MHz
3	2422MHz	9	2452MHz
4	2427MHz	10	2457MHz
5	2432MHz	11	2462MHz
6	2437MHz		

3.2.1 Test Mode Applicability and Tested Channel Detail

EUT CONFIGURE MODE	APPLICABLE TO				DESCRIPTION
	RE \geq 1G	RE $<$ 1G	PLC	APCM	
1	√	√	√	√	Power from USB interface
2	-	-	√	-	Power from Adapter

Where **RE \geq 1G**: Radiated Emission above 1GHz **RE $<$ 1G**: Radiated Emission below 1GHz
PLC: Power Line Conducted Emission **APCM**: Antenna Port Conducted Measurement

NOTE: "-" means no effect.

Radiated Emission Test (Above 1GHz):

- Pre-Scan has been conducted to determine the worst-case mode from all possible combinations between available modulations, data rates and antenna ports (if EUT with antenna diversity architecture).
- Following channel(s) was (were) selected for the final test as listed below.

EUT CONFIGURE MODE	MODE	AVAILABLE CHANNEL	TESTED CHANNEL	MODULATION TECHNOLOGY	MODULATION TYPE	DATA RATE (Mbps)
1	802.11g	1 to 11	1, 6, 11	OFDM	BPSK	6
1	802.11n (HT20)	1 to 11	1, 6, 11	OFDM	BPSK	6.5

Radiated Emission Test (Below 1GHz):

- Pre-Scan has been conducted to determine the worst-case mode from all possible combinations between available modulations, data rates and antenna ports (if EUT with antenna diversity architecture).
- Following channel(s) was (were) selected for the final test as listed below.

EUT CONFIGURE MODE	MODE	AVAILABLE CHANNEL	TESTED CHANNEL	MODULATION TECHNOLOGY	MODULATION TYPE	DATA RATE (Mbps)
1	802.11g	1 to 11	6	OFDM	BPSK	6

Power Line Conducted Emission Test:

- Pre-Scan has been conducted to determine the worst-case mode from all possible combinations between available modulations, data rates and antenna ports (if EUT with antenna diversity architecture).
- Following channel(s) was (were) selected for the final test as listed below.

EUT CONFIGURE MODE	MODE	AVAILABLE CHANNEL	TESTED CHANNEL	MODULATION TECHNOLOGY	MODULATION TYPE	DATA RATE (Mbps)
1	802.11g	1 to 11	6	OFDM	BPSK	6
2	802.11g	1 to 11	6	OFDM	BPSK	6

Antenna Port Conducted Measurement:

- This item includes all test value of each mode, but only includes spectrum plot of worst value of each mode.
- Pre-Scan has been conducted to determine the worst-case mode from all possible combinations between available modulations, data rates and antenna ports (if EUT with antenna diversity architecture).
- Following channel(s) was (were) selected for the final test as listed below.

EUT CONFIGURE MODE	MODE	AVAILABLE CHANNEL	TESTED CHANNEL	MODULATION TECHNOLOGY	MODULATION TYPE	DATA RATE (Mbps)
1	802.11g	1 to 11	1, 6, 11	OFDM	BPSK	6
1	802.11n (HT20)	1 to 11	1, 6, 11	OFDM	BPSK	6.5

Test Condition:

APPLICABLE TO	ENVIRONMENTAL CONDITIONS	INPUT POWER (SYSTEM)	TESTED BY
RE≥1G	22deg. C, 71%RH	120Vac, 60Hz	Gary Cheng
RE<1G	23deg. C, 69%RH	120Vac, 60Hz	Tim Ho
PLC	20deg. C, 60%RH	120Vac, 60Hz	Mike Hsieh
APCM	25deg. C, 60%RH	120Vac, 60Hz	Andy Ho

3.3 Duty Cycle of Test Signal

Duty cycle of test signal is $\geq 98\%$, duty factor is not required.

802.11g: Duty cycle = $1.391\text{ ms} / 1.411\text{ ms} = 0.986$

802.11n (HT20): Duty cycle = $1.308\text{ ms} / 1.319\text{ ms} = 0.992$

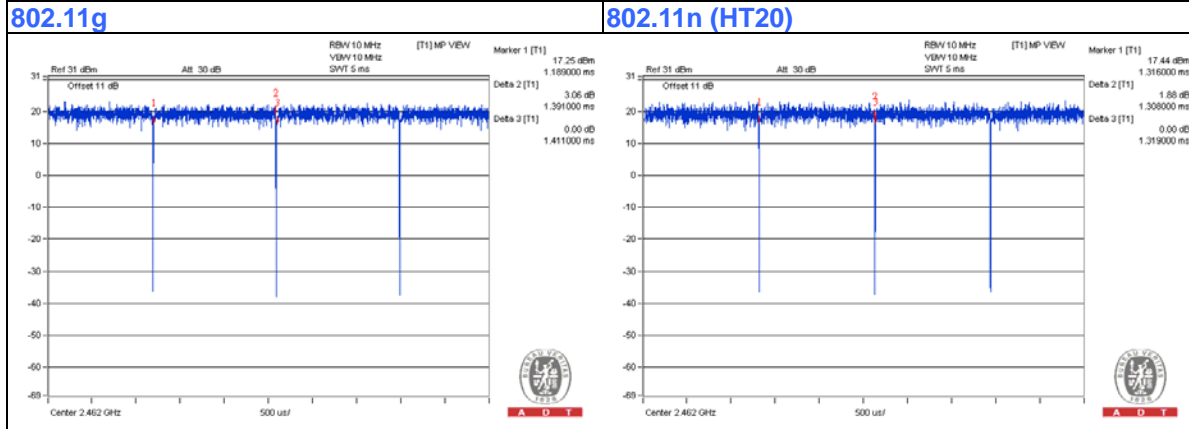

3.4 Description of Support Units

The EUT has been tested as an independent unit together with other necessary accessories or support units. The following support units or accessories were used to form a representative test configuration during the tests.

No.	Product	Brand	Model No.	Serial No.	FCC ID	Remark
A	NOTEBOOK COMPUTER	DELL	E5430	HYV4VY1	FCC DoC	Provided by Lab
B	MONITOR	DELL	U2410F	CNOJ257M728729AG159L	FCC DoC	Provided by Lab
C	RJ45 to USB connector	Logitech	NA	NA	NA	Supplied by Client
D	USB test tool	Logitech	NA	NA	NA	Supplied by Client
E	Test tool	Logitech	NA	NA	NA	Supplied by Client

NOTE:

1. All power cords of the above support units are non-shielded (1.8 m).

No.	Cable	Qty.	Length (m)	Shielded (Yes/ No)	Cores (Number)	Remark
1	DC	1	3	Yes	1	Supplied by Client
2	USB	1	1	Yes	0	Supplied by Client(Set up only)
3	Cable	1	0.5	No	0	Supplied by Client(Set up only)
4	HDMI	1	1.5	No	0	Provided by Lab
5	RJ45	1	1.5	No	0	Supplied by Client(Set up only)
6	USB	1	1	No	0	Supplied by Client(Set up only)
7	USB	1	2	Yes	1	Supplied by Client

Note: The core(s) is(are) originally attached to the cable(s).

3.4.1 Configuration of System under Test

USB mode:

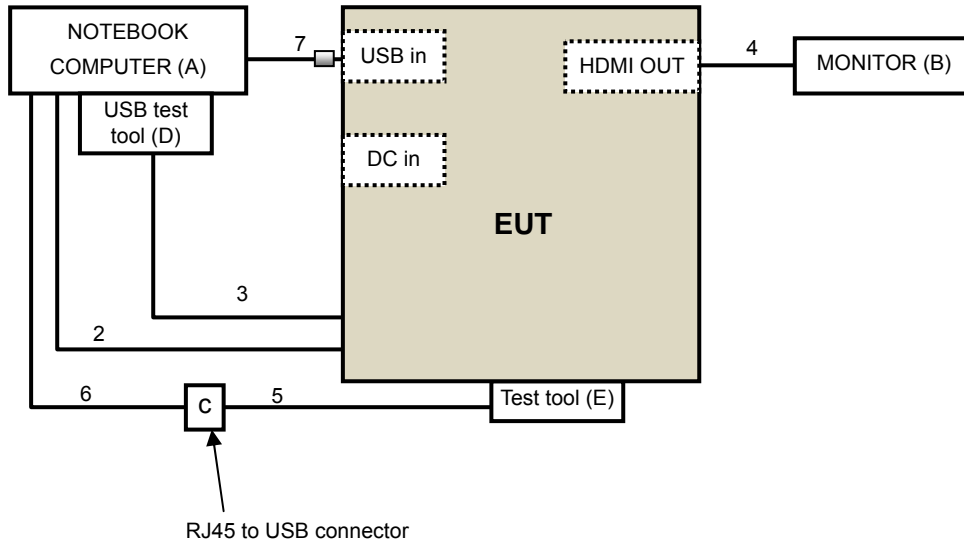

Adapter mode:

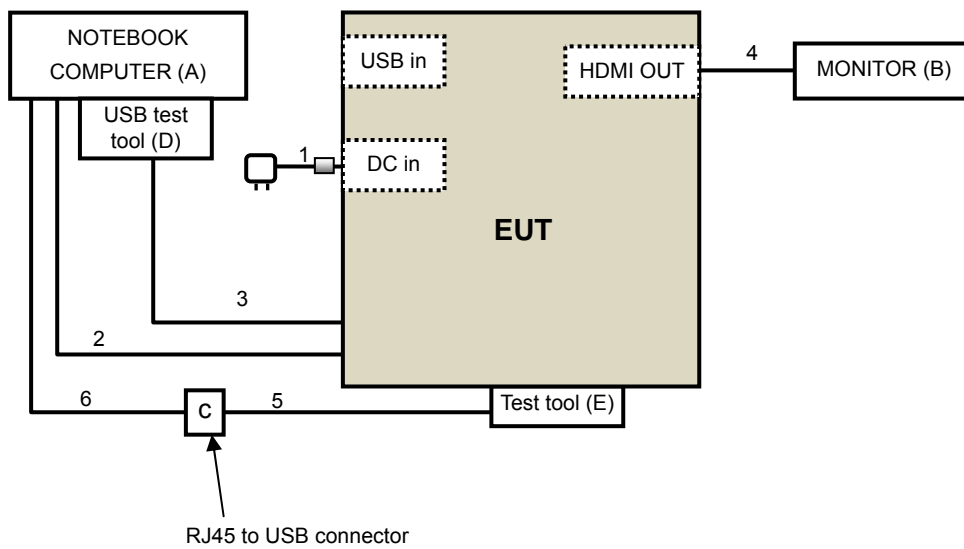

3.5 General Description of Applied Standards

The EUT is a RF Product. According to the specifications of the manufacturer, it must comply with the requirements of the following standards:

FCC Part 15, Subpart C (15.247)
558074 D01 DTS Meas Guidance v03r02
ANSI C63.10-2009

All test items have been performed and recorded as per the above standards.

Note: The EUT has been verified to comply with the requirements of FCC Part 15, Subpart B, Class B (DoC). The test report has been issued separately.

4 Test Types and Results

4.1 Radiated Emission and Bandedge Measurement

4.1.1 Limits of Radiated Emission and Bandedge Measurement

Radiated emissions which fall in the restricted bands must comply with the radiated emission limits specified as below table. Other emissions shall be at least 20dB below the highest level of the desired power:

Frequencies (MHz)	Field Strength (microvolts/meter)	Measurement Distance (meters)
0.009 ~ 0.490	2400/F(kHz)	300
0.490 ~ 1.705	24000/F(kHz)	30
1.705 ~ 30.0	30	30
30 ~ 88	100	3
88 ~ 216	150	3
216 ~ 960	200	3
Above 960	500	3

NOTE:

1. The lower limit shall apply at the transition frequencies.
2. Emission level (dBuV/m) = 20 log Emission level (uV/m).
3. For frequencies above 1000MHz, the field strength limits are based on average detector, however, the peak field strength of any emission shall not exceed the maximum permitted average limits, specified above by more than 20dB under any condition of modulation.

4.1.2 Test Instruments

Below 1GHz test

DESCRIPTION & MANUFACTURER	MODEL NO.	SERIAL NO.	CALIBRATED DATE	CALIBRATED UNTIL
MXE EMI Receiver Agilent	N9038A	MY51210105	July 21, 2014	July 20, 2015
Pre-Amplifier Mini-Circuits	ZFL-1000VH2 B	AMP-ZFL-03	Nov. 12, 2014	Nov. 11, 2015
Trilog Broadband Antenna SCHWARZBECK	VULB 9168	9168-360	Feb. 26, 2014	Feb. 25, 2015
RF Cable	NA	CHGCAB_001	Oct. 04, 2014	Oct. 03, 2015
Horn_Antenna AISI	AIH.8018	0000320091110	Aug. 27, 2014	Aug. 26, 2015
Pre-Amplifier Agilent	8449B	3008A02578	June 24, 2014	June 23, 2015
RF Cable	NA	131205 131214 SNMY23684/4	Jan. 16, 2015	Jan. 15, 2016
Spectrum Analyzer R&S	FSV40	100964	July 05, 2014	July 04, 2015
Pre-Amplifier EMCI	EMC184045	980143	Jan. 16, 2015	Jan. 15, 2016
Horn_Antenna SCHWARZBECK	BBHA 9170	9170-424	Aug. 26, 2014	Aug. 25, 2015
RF Cable	NA	RF104-121 RF104-204	Dec. 11, 2014	Dec. 10, 2015
Antenna Tower & Turn Table CT	NA	NA	NA	NA

Note:

1. The calibration interval of the above test instruments is 12 months and the calibrations are traceable to NML/ROC and NIST/USA.
2. The horn antenna, preamplifier (model: 8449B) are used only for the measurement of emission frequency above 1GHz if tested.
3. The test was performed in 966 Chamber No. G.
4. The FCC Site Registration No. is 966073.
5. The VCCI Site Registration No. is G-137.
6. The CANADA Site Registration No. is IC 7450H-2.
7. Tested Date: Jan. 20, 2015

Above 1GHz test

DESCRIPTION & MANUFACTURER	MODEL NO.	SERIAL NO.	CALIBRATED DATE	CALIBRATED UNTIL
MXE EMI Receiver Agilent	N9038A	MY50010156	Aug. 11, 2014	Aug. 10, 2015
Pre-Amplifier Mini-Circuits	ZFL-1000VH2 B	AMP-ZFL-04	Nov. 12, 2014	Nov. 11, 2015
Trilog Broadband Antenna SCHWARZBECK	VULB 9168	9168-361	Feb. 27, 2014	Feb. 26, 2015
RF Cable	NA	CHHCAB_001	Oct. 05, 2014	Oct. 04, 2015
Horn_Antenna AISI	AIH.8018	0000220091110	Aug. 26, 2014	Aug. 25, 2015
Pre-Amplifier Agilent	8449B	300801923	Oct. 28, 2014	Oct. 27, 2015
RF Cable	NA	131206 131215 SNMY23685/4	Jan. 16, 2015	Jan. 15, 2016
Spectrum Analyzer R&S	FSV40	100964	July 05, 2014	July 04, 2015
Pre-Amplifier EMCI	EMC184045	980143	Jan. 16, 2015	Jan. 15, 2016
Horn_Antenna SCHWARZBECK	BBHA 9170	9170-424	Aug. 26, 2014	Aug. 25, 2015
RF Cable	NA	RF104-121 RF104-204	Dec. 11, 2014	Dec. 10, 2015
Software	ADT_Radiated _V8.7.07	NA	NA	NA
Antenna Tower & Turn Table CT	NA	NA	NA	NA

Note:

1. The calibration interval of the above test instruments is 12 months and the calibrations are traceable to NML/ROC and NIST/USA.
2. The horn antenna, preamplifier (model: 8449B) are used only for the measurement of emission frequency above 1GHz if tested.
- 3 The test was performed in 966 Chamber No. H.
4. The FCC Site Registration No. is 797305.
- 5 The CANADA Site Registration No. is IC 7450H-3.
- 6 Tested Date: Jan. 22, 2015

4.1.3 Test Procedures

- a. The EUT was placed on the top of a rotating table 0.8 meters (for below 1GHz) / 1.5 meters (for above 1GHz) above the ground at 3 meter chamber room for test. The table was rotated 360 degrees to determine the position of the highest radiation.
- b. The EUT was set 3 meters away from the interference-receiving antenna, which was mounted on the top of a variable-height antenna tower.
- c. The height of antenna is varied from one meter to four meters above the ground to determine the maximum value of the field strength. Both horizontal and vertical polarizations of the antenna are set to make the measurement.
- d. For each suspected emission, the EUT was arranged to its worst case and then the antenna was tuned to heights from 1 meter to 4 meters and the rotatable table was turned from 0 degrees to 360 degrees to find the maximum reading.
- e. The test-receiver system was set to quasi-peak detect function and specified bandwidth with maximum hold mode when the test frequency is below 1 GHz.
- f. The test-receiver system was set to peak and average detect function and specified bandwidth with maximum hold mode when the test frequency is above 1 GHz. If the peak reading value also meets average limit, measurement with the average detector is unnecessary.

Note:

1. The resolution bandwidth and video bandwidth of test receiver/spectrum analyzer is 120kHz for Quasi-peak detection (QP) at frequency below 1GHz.
2. The resolution bandwidth of test receiver/spectrum analyzer is 1 MHz and the video bandwidth is 3 MHz for Peak detection (PK) at frequency above 1GHz.
3. The resolution bandwidth of test receiver/spectrum analyzer is 1MHz and the video bandwidth is 3MHz for RMS Average (Duty cycle < 98%) for Average detection (AV) at frequency above 1GHz, then the measurement results was added to a correction factor ($10 \log(1/\text{duty cycle})$).
4. The resolution bandwidth of test receiver/spectrum analyzer is 1MHz and the video bandwidth is 10Hz (Duty cycle $\geq 98\%$) for Average detection (AV) at frequency above 1GHz.
5. All modes of operation were investigated and the worst-case emissions are reported.

4.1.4 Deviation from Test Standard

No deviation.

4.1.5 Test Set Up

<Frequency Range below 1GHz>

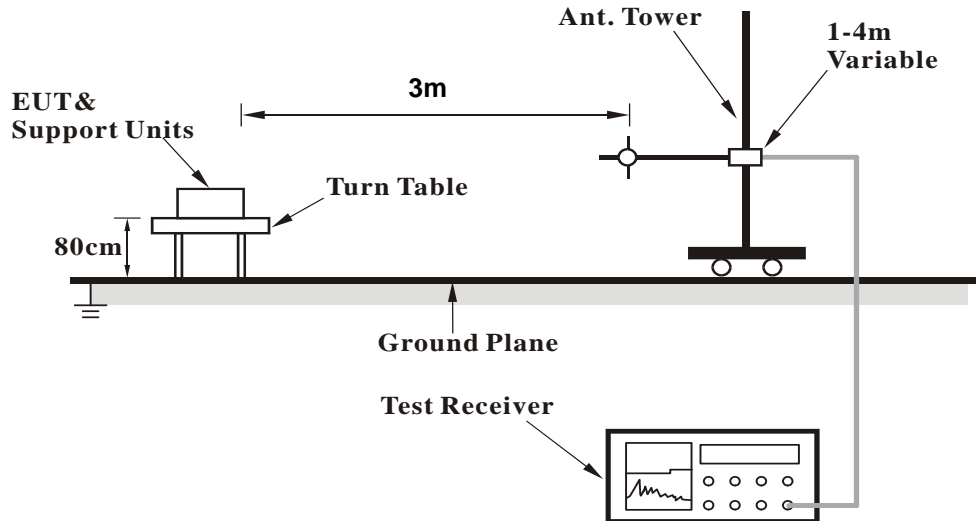

<Frequency Range above 1GHz>

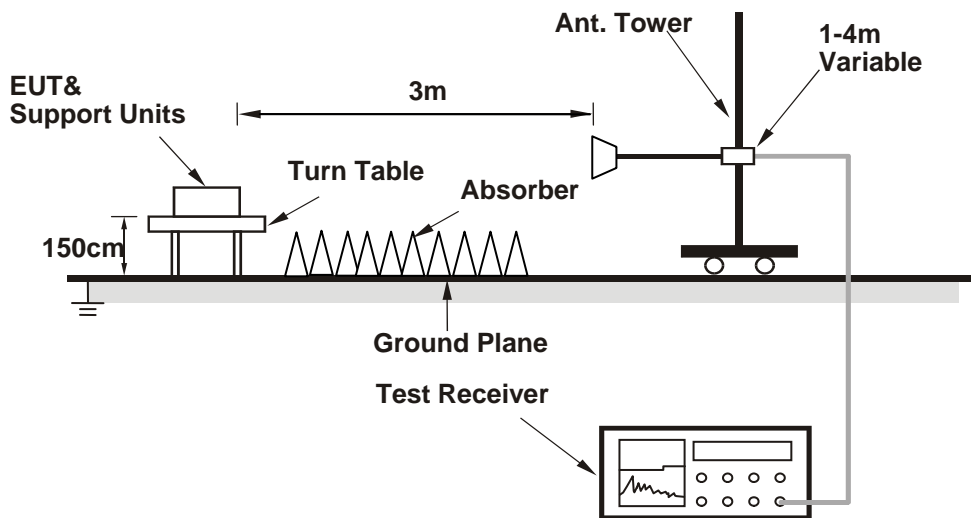

For the actual test configuration, please refer to the attached file (Test Setup Photo).

4.1.6 EUT Operating Conditions

1. Placed the EUT on testing table.
2. Controlling software (MtkTool.exe) has been activated to set the EUT under transmission/receiving condition continuously.

4.1.7 Test Results

ABOVE 1GHz DATA

802.11g

CHANNEL	TX Channel 1	DETECTOR FUNCTION	Peak (PK)
FREQUENCY RANGE	1GHz ~ 25GHz		Average (AV)

ANTENNA POLARITY & TEST DISTANCE: HORIZONTAL AT 3 M

NO.	FREQ. (MHz)	EMISSION LEVEL (dBuV/m)	LIMIT (dBuV/m)	MARGIN (dB)	ANTENNA HEIGHT (m)	TABLE ANGLE (Degree)	RAW VALUE (dBuV)	CORRECTION FACTOR (dB/m)
1	2390.00	70.5 PK	74.0	-3.5	1.00 H	243	76.10	-5.60
2	2390.00	50.4 AV	54.0	-3.6	1.00 H	243	56.00	-5.60
3	*2412.00	107.3 PK			1.00 H	243	112.83	-5.53
4	*2412.00	96.9 AV			1.00 H	243	102.43	-5.53
5	4824.00	53.4 PK	74.0	-20.6	1.08 H	220	49.54	3.86
6	4824.00	41.4 AV	54.0	-12.6	1.08 H	220	37.54	3.86

ANTENNA POLARITY & TEST DISTANCE: VERTICAL AT 3 M

NO.	FREQ. (MHz)	EMISSION LEVEL (dBuV/m)	LIMIT (dBuV/m)	MARGIN (dB)	ANTENNA HEIGHT (m)	TABLE ANGLE (Degree)	RAW VALUE (dBuV)	CORRECTION FACTOR (dB/m)
1	2390.00	67.1 PK	74.0	-6.9	1.66 V	162	72.70	-5.60
2	2390.00	48.3 AV	54.0	-5.7	1.66 V	162	53.90	-5.60
3	*2412.00	105.3 PK			1.66 V	162	110.83	-5.53
4	*2412.00	95.0 AV			1.66 V	162	100.53	-5.53
5	4824.00	55.6 PK	74.0	-18.4	1.12 V	230	51.74	3.86
6	4824.00	43.1 AV	54.0	-10.9	1.12 V	230	39.24	3.86

REMARKS:

1. Emission Level(dBuV/m) = Raw Value(dBuV) + Correction Factor(dB/m)
2. Correction Factor(dB/m) = Antenna Factor(dB/m) + Cable Factor(dB) – Pre-Amplifier Factor(dB)
3. The other emission levels were very low against the limit.
4. Margin value = Emission Level – Limit value
5. " * ": Fundamental frequency.

CHANNEL	TX Channel 6	DETECTOR FUNCTION	Peak (PK)
FREQUENCY RANGE	1GHz ~ 25GHz		Average (AV)

ANTENNA POLARITY & TEST DISTANCE: HORIZONTAL AT 3 M

NO.	FREQ. (MHz)	EMISSION LEVEL (dBuV/m)	LIMIT (dBuV/m)	MARGIN (dB)	ANTENNA HEIGHT (m)	TABLE ANGLE (Degree)	RAW VALUE (dBuV)	CORRECTION FACTOR (dB/m)
1	2390.00	52.1 PK	74.0	-21.9	1.05 H	242	57.70	-5.60
2	2390.00	39.9 AV	54.0	-14.1	1.05 H	242	45.50	-5.60
3	*2437.00	107.8 PK			1.05 H	242	113.22	-5.42
4	*2437.00	97.3 AV			1.05 H	242	102.72	-5.42
5	2483.50	51.1 PK	74.0	-22.9	1.05 H	242	56.30	-5.20
6	2483.50	38.7 AV	54.0	-15.3	1.05 H	242	43.90	-5.20
7	4874.00	54.0 PK	74.0	-20.0	1.05 H	204	50.19	3.81
8	4874.00	41.8 AV	54.0	-12.2	1.05 H	204	37.99	3.81
9	7311.00	52.4 PK	74.0	-21.6	1.04 H	124	44.17	8.23
10	7311.00	40.3 AV	54.0	-13.7	1.04 H	124	32.07	8.23

ANTENNA POLARITY & TEST DISTANCE: VERTICAL AT 3 M

NO.	FREQ. (MHz)	EMISSION LEVEL (dBuV/m)	LIMIT (dBuV/m)	MARGIN (dB)	ANTENNA HEIGHT (m)	TABLE ANGLE (Degree)	RAW VALUE (dBuV)	CORRECTION FACTOR (dB/m)
1	2390.00	51.3 PK	74.0	-22.7	1.64 V	157	56.90	-5.60
2	2390.00	38.4 AV	54.0	-15.6	1.64 V	157	44.00	-5.60
3	*2437.00	105.0 PK			1.64 V	157	110.42	-5.42
4	*2437.00	94.8 AV			1.64 V	157	100.22	-5.42
5	2483.50	50.3 PK	74.0	-23.7	1.64 V	157	55.50	-5.20
6	2483.50	37.2 AV	54.0	-16.8	1.64 V	157	42.40	-5.20
7	4874.00	55.1 PK	74.0	-18.9	1.13 V	243	51.29	3.81
8	4874.00	42.7 AV	54.0	-11.3	1.13 V	243	38.89	3.81
9	7311.00	52.8 PK	74.0	-21.2	1.16 V	240	44.57	8.23
10	7311.00	40.8 AV	54.0	-13.2	1.16 V	240	32.57	8.23

REMARKS:

1. Emission Level(dBuV/m) = Raw Value(dBuV) + Correction Factor(dB/m)
2. Correction Factor(dB/m) = Antenna Factor(dB/m) + Cable Factor(dB) – Pre-Amplifier Factor(dB)
3. The other emission levels were very low against the limit.
4. Margin value = Emission Level – Limit value
5. " * ": Fundamental frequency.

CHANNEL	TX Channel 11	DETECTOR FUNCTION	Peak (PK)
FREQUENCY RANGE	1GHz ~ 25GHz		Average (AV)

ANTENNA POLARITY & TEST DISTANCE: HORIZONTAL AT 3 M

NO.	FREQ. (MHz)	EMISSION LEVEL (dBuV/m)	LIMIT (dBuV/m)	MARGIN (dB)	ANTENNA HEIGHT (m)	TABLE ANGLE (Degree)	RAW VALUE (dBuV)	CORRECTION FACTOR (dB/m)
1	*2462.00	107.7 PK			1.02 H	240	113.01	-5.31
2	*2462.00	97.3 AV			1.02 H	240	102.61	-5.31
3	2483.50	68.2 PK	74.0	-5.8	1.02 H	240	73.40	-5.20
4	2483.50	50.2 AV	54.0	-3.8	1.02 H	240	55.40	-5.20
5	4924.00	54.3 PK	74.0	-19.7	1.05 H	209	50.50	3.80
6	4924.00	41.9 AV	54.0	-12.1	1.05 H	209	38.10	3.80
7	7386.00	52.4 PK	74.0	-21.6	1.02 H	131	43.85	8.55
8	7386.00	40.4 AV	54.0	-13.6	1.02 H	131	31.85	8.55

ANTENNA POLARITY & TEST DISTANCE: VERTICAL AT 3 M

NO.	FREQ. (MHz)	EMISSION LEVEL (dBuV/m)	LIMIT (dBuV/m)	MARGIN (dB)	ANTENNA HEIGHT (m)	TABLE ANGLE (Degree)	RAW VALUE (dBuV)	CORRECTION FACTOR (dB/m)
1	*2462.00	104.4 PK			1.63 V	146	109.71	-5.31
2	*2462.00	94.5 AV			1.63 V	146	99.81	-5.31
3	2483.50	66.4 PK	74.0	-7.6	1.63 V	146	71.60	-5.20
4	2483.50	48.2 AV	54.0	-5.8	1.63 V	146	53.40	-5.20
5	4924.00	55.5 PK	74.0	-18.5	1.19 V	237	51.70	3.80
6	4924.00	42.8 AV	54.0	-11.2	1.19 V	237	39.00	3.80
7	7386.00	52.3 PK	74.0	-21.7	1.11 V	255	43.75	8.55
8	7386.00	40.5 AV	54.0	-13.5	1.11 V	255	31.95	8.55

REMARKS:

1. Emission Level(dBuV/m) = Raw Value(dBuV) + Correction Factor(dB/m)
2. Correction Factor(dB/m) = Antenna Factor(dB/m) + Cable Factor(dB) – Pre-Amplifier Factor(dB)
3. The other emission levels were very low against the limit.
4. Margin value = Emission Level – Limit value
5. " * ": Fundamental frequency.

802.11n (HT20)

CHANNEL	TX Channel 1	DETECTOR FUNCTION	Peak (PK)
FREQUENCY RANGE	1GHz ~ 25GHz		Average (AV)

ANTENNA POLARITY & TEST DISTANCE: HORIZONTAL AT 3 M								
NO.	FREQ. (MHz)	EMISSION LEVEL (dBuV/m)	LIMIT (dBuV/m)	MARGIN (dB)	ANTENNA HEIGHT (m)	TABLE ANGLE (Degree)	RAW VALUE (dBuV)	CORRECTION FACTOR (dB/m)
1	2390.00	70.6 PK	74.0	-3.4	1.00 H	243	76.20	-5.60
2	2390.00	53.0 AV	54.0	-1.0	1.00 H	243	58.60	-5.60
3	*2412.00	106.5 PK			1.00 H	243	112.03	-5.53
4	*2412.00	96.3 AV			1.00 H	243	101.83	-5.53
5	4824.00	53.3 PK	74.0	-20.7	1.12 H	226	49.44	3.86
6	4824.00	41.1 AV	54.0	-12.9	1.12 H	226	37.24	3.86

ANTENNA POLARITY & TEST DISTANCE: VERTICAL AT 3 M								
NO.	FREQ. (MHz)	EMISSION LEVEL (dBuV/m)	LIMIT (dBuV/m)	MARGIN (dB)	ANTENNA HEIGHT (m)	TABLE ANGLE (Degree)	RAW VALUE (dBuV)	CORRECTION FACTOR (dB/m)
1	2390.00	67.4 PK	74.0	-6.6	1.65 V	152	73.00	-5.60
2	2390.00	48.7 AV	54.0	-5.3	1.65 V	152	54.30	-5.60
3	*2412.00	104.9 PK			1.65 V	152	110.43	-5.53
4	*2412.00	94.7 AV			1.65 V	152	100.23	-5.53
5	4824.00	56.1 PK	74.0	-17.9	1.15 V	239	52.24	3.86
6	4824.00	43.6 AV	54.0	-10.4	1.15 V	239	39.74	3.86

REMARKS:

1. Emission Level(dBuV/m) = Raw Value(dBuV) + Correction Factor(dB/m)
2. Correction Factor(dB/m) = Antenna Factor(dB/m) + Cable Factor(dB) – Pre-Amplifier Factor(dB)
3. The other emission levels were very low against the limit.
4. Margin value = Emission Level – Limit value
5. " * ": Fundamental frequency.

CHANNEL	TX Channel 6	DETECTOR FUNCTION	Peak (PK)
FREQUENCY RANGE	1GHz ~ 25GHz		Average (AV)

ANTENNA POLARITY & TEST DISTANCE: HORIZONTAL AT 3 M

NO.	FREQ. (MHz)	EMISSION LEVEL (dBuV/m)	LIMIT (dBuV/m)	MARGIN (dB)	ANTENNA HEIGHT (m)	TABLE ANGLE (Degree)	RAW VALUE (dBuV)	CORRECTION FACTOR (dB/m)
1	2390.00	52.7 PK	74.0	-21.3	1.22 H	241	58.30	-5.60
2	2390.00	40.0 AV	54.0	-14.0	1.22 H	241	45.60	-5.60
3	*2437.00	106.9 PK			1.22 H	241	112.32	-5.42
4	*2437.00	96.6 AV			1.22 H	241	102.02	-5.42
5	2483.50	54.5 PK	74.0	-19.5	1.22 H	241	59.70	-5.20
6	2483.50	39.6 AV	54.0	-14.4	1.22 H	241	44.80	-5.20
7	4874.00	54.3 PK	74.0	-19.7	1.01 H	200	50.49	3.81
8	4874.00	41.9 AV	54.0	-12.1	1.01 H	200	38.09	3.81
9	7311.00	51.9 PK	74.0	-22.1	1.09 H	111	43.67	8.23
10	7311.00	40.0 AV	54.0	-14.0	1.09 H	111	31.77	8.23

ANTENNA POLARITY & TEST DISTANCE: VERTICAL AT 3 M

NO.	FREQ. (MHz)	EMISSION LEVEL (dBuV/m)	LIMIT (dBuV/m)	MARGIN (dB)	ANTENNA HEIGHT (m)	TABLE ANGLE (Degree)	RAW VALUE (dBuV)	CORRECTION FACTOR (dB/m)
1	2390.00	51.5 PK	74.0	-22.5	1.69 V	150	57.10	-5.60
2	2390.00	38.5 AV	54.0	-15.5	1.69 V	150	44.10	-5.60
3	*2437.00	104.4 PK			1.69 V	150	109.82	-5.42
4	*2437.00	94.3 AV			1.69 V	150	99.72	-5.42
5	2483.50	50.9 PK	74.0	-23.1	1.69 V	150	56.10	-5.20
6	2483.50	37.6 AV	54.0	-16.4	1.69 V	150	42.80	-5.20
7	4874.00	55.7 PK	74.0	-18.3	1.10 V	242	51.89	3.81
8	4874.00	43.0 AV	54.0	-11.0	1.10 V	242	39.19	3.81
9	7311.00	52.9 PK	74.0	-21.1	1.13 V	238	44.67	8.23
10	7311.00	40.7 AV	54.0	-13.3	1.13 V	238	32.47	8.23

REMARKS:

1. Emission Level(dBuV/m) = Raw Value(dBuV) + Correction Factor(dB/m)
2. Correction Factor(dB/m) = Antenna Factor(dB/m) + Cable Factor(dB) – Pre-Amplifier Factor(dB)
3. The other emission levels were very low against the limit.
4. Margin value = Emission Level – Limit value
5. " * ": Fundamental frequency.

CHANNEL	TX Channel 11	DETECTOR FUNCTION	Peak (PK)
FREQUENCY RANGE	1GHz ~ 25GHz		Average (AV)

ANTENNA POLARITY & TEST DISTANCE: HORIZONTAL AT 3 M

NO.	FREQ. (MHz)	EMISSION LEVEL (dBuV/m)	LIMIT (dBuV/m)	MARGIN (dB)	ANTENNA HEIGHT (m)	TABLE ANGLE (Degree)	RAW VALUE (dBuV)	CORRECTION FACTOR (dB/m)
1	*2462.00	106.1 PK			1.25 H	242	111.41	-5.31
2	*2462.00	96.1 AV			1.25 H	242	101.41	-5.31
3	2483.50	71.7 PK	74.0	-2.3	1.25 H	242	76.90	-5.20
4	2483.50	51.3 AV	54.0	-2.7	1.25 H	242	56.50	-5.20
5	4924.00	54.2 PK	74.0	-19.8	1.00 H	200	50.40	3.80
6	4924.00	41.7 AV	54.0	-12.3	1.00 H	200	37.90	3.80
7	7386.00	52.8 PK	74.0	-21.2	1.00 H	127	44.25	8.55
8	7386.00	40.6 AV	54.0	-13.4	1.00 H	127	32.05	8.55

ANTENNA POLARITY & TEST DISTANCE: VERTICAL AT 3 M

NO.	FREQ. (MHz)	EMISSION LEVEL (dBuV/m)	LIMIT (dBuV/m)	MARGIN (dB)	ANTENNA HEIGHT (m)	TABLE ANGLE (Degree)	RAW VALUE (dBuV)	CORRECTION FACTOR (dB/m)
1	*2462.00	104.2 PK			1.66 V	157	109.51	-5.31
2	*2462.00	94.6 AV			1.66 V	157	99.91	-5.31
3	2483.50	67.4 PK	74.0	-6.6	1.66 V	157	72.60	-5.20
4	2483.50	49.3 AV	54.0	-4.7	1.66 V	157	54.50	-5.20
5	4924.00	55.6 PK	74.0	-18.4	1.20 V	230	51.80	3.80
6	4924.00	42.7 AV	54.0	-11.3	1.20 V	230	38.90	3.80
7	7386.00	52.0 PK	74.0	-22.0	1.08 V	242	43.45	8.55
8	7386.00	40.2 AV	54.0	-13.8	1.08 V	242	31.65	8.55

REMARKS:

1. Emission Level(dBuV/m) = Raw Value(dBuV) + Correction Factor(dB/m)
2. Correction Factor(dB/m) = Antenna Factor(dB/m) + Cable Factor(dB) – Pre-Amplifier Factor(dB)
3. The other emission levels were very low against the limit.
4. Margin value = Emission Level – Limit value
5. " * ": Fundamental frequency.

BELOW 1GHz WORST-CASE DATA
802.11g

CHANNEL	TX Channel 6	DETECTOR FUNCTION	Quasi-Peak (QP)
FREQUENCY RANGE	Below 1GHz		

ANTENNA POLARITY & TEST DISTANCE: HORIZONTAL AT 3 M

NO.	FREQ. (MHz)	EMISSION LEVEL (dBuV/m)	LIMIT (dBuV/m)	MARGIN (dB)	ANTENNA HEIGHT (m)	TABLE ANGLE (Degree)	RAW VALUE (dBuV)	CORRECTION FACTOR (dB/m)
1	98.34	33.0 QP	43.5	-10.5	2.00 H	195	50.88	-17.87
2	184.33	37.0 QP	43.5	-6.6	1.50 H	205	51.77	-14.82
3	233.46	32.5 QP	46.0	-13.6	1.00 H	332	47.49	-15.04
4	479.98	34.0 QP	46.0	-12.0	2.00 H	160	41.16	-7.12
5	499.97	33.7 QP	46.0	-12.3	1.50 H	271	40.44	-6.75
6	959.99	35.1 QP	46.0	-10.9	2.00 H	167	33.30	1.77

ANTENNA POLARITY & TEST DISTANCE: VERTICAL AT 3 M

NO.	FREQ. (MHz)	EMISSION LEVEL (dBuV/m)	LIMIT (dBuV/m)	MARGIN (dB)	ANTENNA HEIGHT (m)	TABLE ANGLE (Degree)	RAW VALUE (dBuV)	CORRECTION FACTOR (dB/m)
1	98.34	30.7 QP	43.5	-12.8	2.00 V	291	48.57	-17.87
2	184.33	39.4 QP	43.5	-4.1	1.00 V	322	54.23	-14.82
3	233.46	34.3 QP	46.0	-11.8	1.00 V	163	49.29	-15.04
4	380.95	35.7 QP	46.0	-10.3	1.50 V	98	45.33	-9.61
5	405.49	36.3 QP	46.0	-9.7	1.00 V	193	45.40	-9.12
6	959.99	35.0 QP	46.0	-11.0	1.00 V	360	33.24	1.77

REMARKS:

1. Emission Level(dBuV/m) = Raw Value(dBuV) + Correction Factor(dB/m)
2. Correction Factor(dB/m) = Antenna Factor(dB/m) + Cable Factor(dB) – Pre-Amplifier Factor(dB)
3. The other emission levels were very low against the limit.
4. Margin value = Emission Level – Limit value

4.2 Conducted Emission Measurement

4.2.1 Limits of Conducted Emission Measurement

Frequency (MHz)	Conducted Limit (dBuV)	
	Quasi-peak	Average
0.15 - 0.5	66 - 56	56 - 46
0.50 - 5.0	56	46
5.0 - 30.0	60	50

Note: 1. The lower limit shall apply at the transition frequencies.

2. The limit decreases in line with the logarithm of the frequency in the range of 0.15 to 0.50MHz.

4.2.2 Test Instruments

DESCRIPTION & MANUFACTURER	MODEL NO.	SERIAL NO.	CALIBRATED DATE	CALIBRATED UNTIL
Test Receiver ROHDE & SCHWARZ	ESCS 30	100375	Apr. 29, 2014	Apr. 28, 2015
Line-Impedance Stabilization Network (for EUT) SCHWARZBECK	NSLK-8127	8127-522	Sep. 15, 2014	Sep. 14, 2015
Line-Impedance Stabilization Network (for Peripheral) ROHDE & SCHWARZ	ENV216	100071	Nov. 10, 2014	Nov. 09, 2015
RF Cable (JYEBAO)	5DFB	COCCAB-001	Mar. 10, 2014	Mar. 09, 2015
50 ohms Terminator	N/A	EMC-03	Sep. 22, 2014	Sep. 21, 2015
50 ohms Terminator	N/A	EMC-02	Sep. 30, 2014	Sep. 29, 2015
Software ADT	BV ADT_Cond_V7.3.7. 3	NA	NA	NA

Note:

1. The calibration interval of the above test instruments is 12 months and the calibrations are traceable to NML/ROC and NIST/USA.
2. The test was performed in Shielded Room No. C.
3. The VCCI Con C Registration No. is C-3611.
4. Tested Date: Jan. 22, 2015

4.2.3 Test Procedures

- a. The EUT was placed 0.4 meters from the conducting wall of the shielded room with EUT being connected to the power mains through a line impedance stabilization network (LISN). Other support units were connected to the power mains through another LISN. The two LISNs provide 50 ohm/ 50uH of coupling impedance for the measuring instrument.
- b. Both lines of the power mains connected to the EUT were checked for maximum conducted interference.
- c. The frequency range from 150kHz to 30MHz was searched. Emission levels under (Limit - 20dB) was not recorded.

NOTE: The resolution bandwidth and video bandwidth of test receiver is 9kHz for quasi-peak detection (QP) and average detection (AV) at frequency 0.15MHz-30MHz.

4.2.4 Deviation from Test Standard

No deviation.

4.2.5 Test Setup

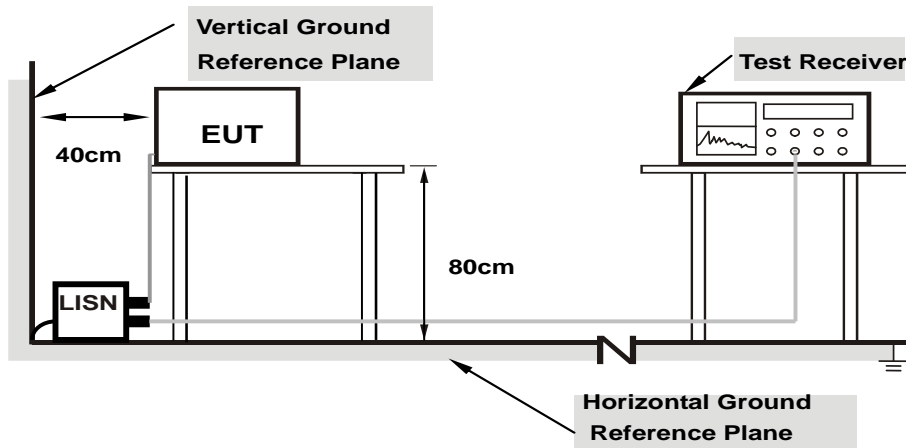

- Note: 1.Support units were connected to second LISN.**
2.Both of LISNs (AMN) are 80 cm from EUT and at least 80 from other units and other metal planes

For the actual test configuration, please refer to the attached file (Test Setup Photo).

4.2.6 EUT Operating Conditions

Same as 4.1.6.

4.2.7 Test Results (Mode 1)

Phase	Line (L)	Detector Function	Quasi-Peak (QP) / Average (AV)
-------	----------	-------------------	--------------------------------

No	Freq. [MHz]	Corr.	Reading Value		Emission Level		Limit		Margin	
		Factor	[dB (uV)]		[dB (uV)]		[dB (uV)]		(dB)	
	(dB)	Q.P.	AV.	Q.P.	AV.	Q.P.	AV.	Q.P.	AV.	
1	0.16562	0.07	29.20	26.31	29.27	26.38	65.18	55.18	-35.91	-28.80
2	0.42344	0.09	34.12	32.84	34.21	32.93	57.38	47.38	-23.17	-14.45
3	0.88828	0.12	30.58	25.44	30.70	25.56	56.00	46.00	-25.30	-20.44
4	2.02344	0.18	35.76	31.88	35.94	32.06	56.00	46.00	-20.06	-13.94
5	14.08594	0.56	19.93	14.52	20.49	15.08	60.00	50.00	-39.51	-34.92
6	28.50000	0.88	23.43	18.85	24.31	19.73	60.00	50.00	-35.69	-30.27

REMARKS:

1. Q.P. and AV. are abbreviations of quasi-peak and average individually.
2. The emission levels of other frequencies were very low against the limit.
3. Margin value = Emission level - Limit value
4. Correction factor = Insertion loss + Cable loss
5. Emission Level = Correction Factor + Reading Value.

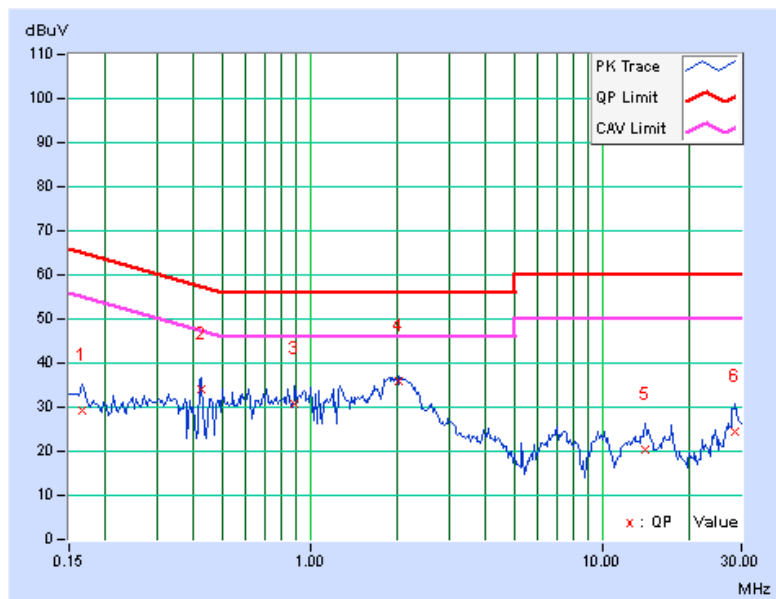

Phase	Neutral (N)	Detector Function	Quasi-Peak (QP) / Average (AV)
-------	-------------	-------------------	--------------------------------

No	Freq. [MHz]	Corr.	Reading Value		Emission Level		Limit		Margin	
		Factor	[dB (uV)]		[dB (uV)]		[dB (uV)]		(dB)	
		(dB)	Q.P.	AV.	Q.P.	AV.	Q.P.	AV.	Q.P.	AV.
1	0.15000	0.07	31.74	26.85	31.81	26.92	66.00	56.00	-34.19	-29.08
2	0.41953	0.09	33.59	26.04	33.68	26.13	57.46	47.46	-23.78	-21.33
3	0.64609	0.11	28.08	24.72	28.19	24.83	56.00	46.00	-27.81	-21.17
4	1.35156	0.15	29.17	18.46	29.32	18.61	56.00	46.00	-26.68	-27.39
5	1.93750	0.18	34.45	31.25	34.63	31.43	56.00	46.00	-21.37	-14.57
6	7.19531	0.37	22.84	17.40	23.21	17.77	60.00	50.00	-36.79	-32.23

REMARKS:

1. Q.P. and AV. are abbreviations of quasi-peak and average individually.
2. The emission levels of other frequencies were very low against the limit.
3. Margin value = Emission level - Limit value
4. Correction factor = Insertion loss + Cable loss
5. Emission Level = Correction Factor + Reading Value.

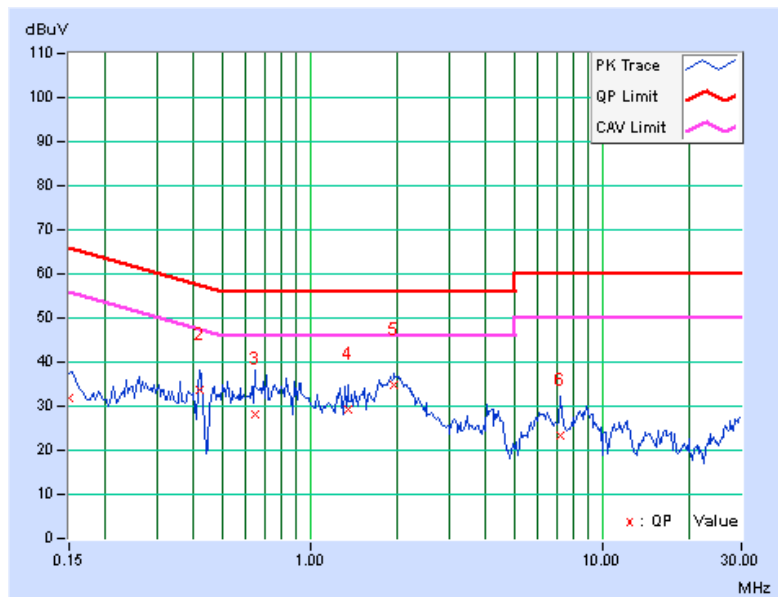

4.2.8 Test Results (Mode 2)

Phase	Line (L)	Detector Function	Quasi-Peak (QP) / Average (AV)
-------	----------	-------------------	--------------------------------

No	Freq. [MHz]	Corr.	Reading Value		Emission Level		Limit		Margin	
		Factor	[dB (uV)]		[dB (uV)]		[dB (uV)]		(dB)	
	(dB)	Q.P.	AV.	Q.P.	AV.	Q.P.	AV.	Q.P.	AV.	
1	0.16172	0.07	35.17	26.89	35.24	26.96	65.38	55.38	-30.14	-28.42
2	0.30234	0.08	43.90	43.50	43.98	43.58	60.18	50.18	-16.20	-6.60
3	0.87266	0.12	26.75	20.74	26.87	20.86	56.00	46.00	-29.13	-25.14
4	2.01172	0.18	34.06	28.25	34.24	28.43	56.00	46.00	-21.76	-17.57
5	5.00000	0.28	25.63	16.26	25.91	16.54	56.00	46.00	-30.09	-29.46
6	15.55469	0.60	18.40	12.32	19.00	12.92	60.00	50.00	-41.00	-37.08

REMARKS:

1. Q.P. and AV. are abbreviations of quasi-peak and average individually.
2. The emission levels of other frequencies were very low against the limit.
3. Margin value = Emission level - Limit value
4. Correction factor = Insertion loss + Cable loss
5. Emission Level = Correction Factor + Reading Value.

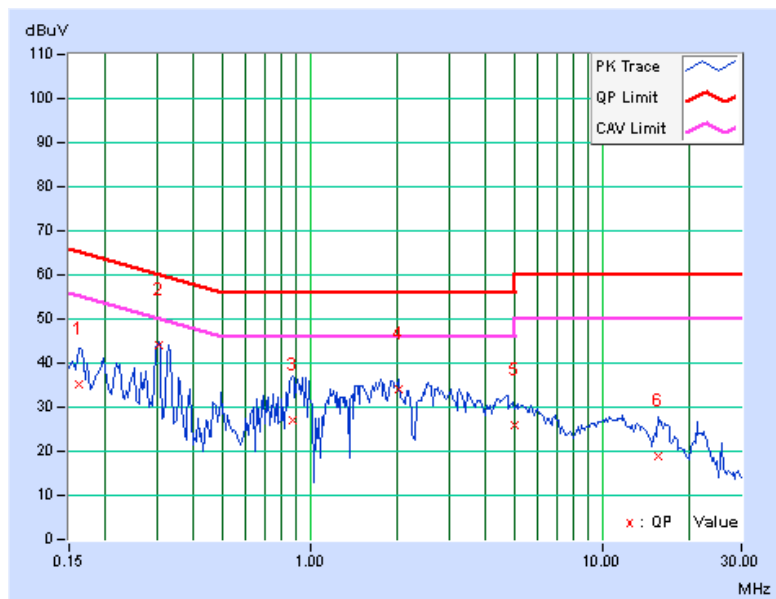

Phase	Neutral (N)	Detector Function	Quasi-Peak (QP) / Average (AV)
-------	-------------	-------------------	--------------------------------

No	Freq. [MHz]	Corr.	Reading Value		Emission Level		Limit		Margin	
		Factor	[dB (uV)]		[dB (uV)]		[dB (uV)]		(dB)	
		(dB)	Q.P.	AV.	Q.P.	AV.	Q.P.	AV.	Q.P.	AV.
1	0.30234	0.08	43.13	43.06	43.21	43.14	60.18	50.18	-16.97	-7.04
2	0.98203	0.13	32.25	31.33	32.38	31.46	56.00	46.00	-23.62	-14.54
3	1.42188	0.15	33.03	32.45	33.18	32.60	56.00	46.00	-22.82	-13.40
4	2.54297	0.20	33.26	28.95	33.46	29.15	56.00	46.00	-22.54	-16.85
5	11.64844	0.51	27.55	22.75	28.06	23.26	60.00	50.00	-31.94	-26.74
6	21.19531	0.77	24.24	19.99	25.01	20.76	60.00	50.00	-34.99	-29.24

REMARKS:

1. Q.P. and AV. are abbreviations of quasi-peak and average individually.
2. The emission levels of other frequencies were very low against the limit.
3. Margin value = Emission level - Limit value
4. Correction factor = Insertion loss + Cable loss
5. Emission Level = Correction Factor + Reading Value.

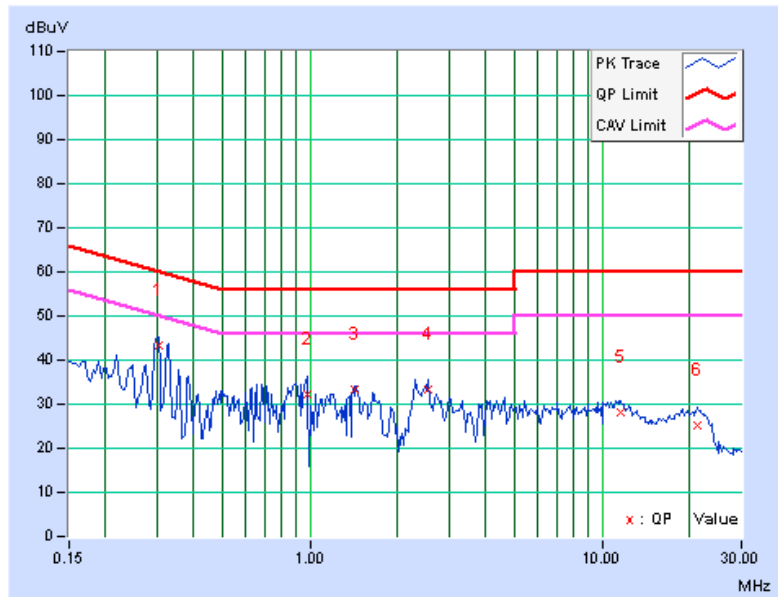

4.3 6dB Bandwidth Measurement

4.3.1 Limits of 6dB Bandwidth Measurement

The minimum of 6dB Bandwidth Measurement is 0.5 MHz.

4.3.2 Test Setup

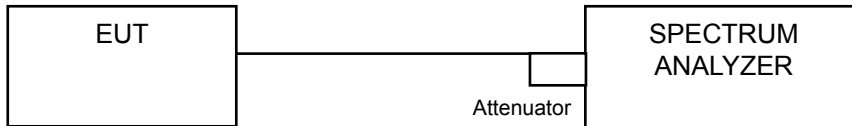

4.3.3 Test Instruments

DESCRIPTION & MANUFACTURER	MODEL NO.	SERIAL NO.	CALIBRATED DATE	CALIBRATED UNTIL
SPECTRUM ANALYZER R&S	FSP 40	100060	May 08, 2014	May 07, 2015

- NOTE:**
1. The test was performed in Oven room B.
 2. The calibration interval of the above test instruments is 12 months and the calibrations are traceable to NML/ROC and NIST/USA.
 3. Tested Date: Jan. 22, 2015

4.3.4 Test Procedure

- a. Set resolution bandwidth (RBW) = 100kHz
- b. Set the video bandwidth (VBW) ≥ 3 x RBW, Detector = Peak.
- c. Trace mode = max hold.
- d. Sweep = auto couple.
- e. Measure the maximum width of the emission that is constrained by the frequencies associated with the two amplitude points (upper and lower) that are attenuated by 6 dB relative to the maximum level measured in the fundamental emission

4.3.5 Deviation from Test Standard

No deviation.

4.3.6 EUT Operating Conditions

The software provided by client to enable the EUT under transmission condition continuously at lowest, middle and highest channel frequencies individually.

4.3.7 Test Result

802.11g

CHANNEL	FREQUENCY (MHz)	6dB BANDWIDTH (MHz)	MINIMUM LIMIT (MHz)	PASS / FAIL
1	2412	16.35	0.5	PASS
6	2437	16.36	0.5	PASS
11	2462	16.35	0.5	PASS

802.11n (HT20)

CHANNEL	FREQUENCY (MHz)	6dB BANDWIDTH (MHz)	MINIMUM LIMIT (MHz)	PASS / FAIL
1	2412	16.33	0.5	PASS
6	2437	16.57	0.5	PASS
11	2462	16.36	0.5	PASS

SPECTRUM PLOT OF WORST VALUE

802.11g / CH1

802.11n (HT20) / CH1

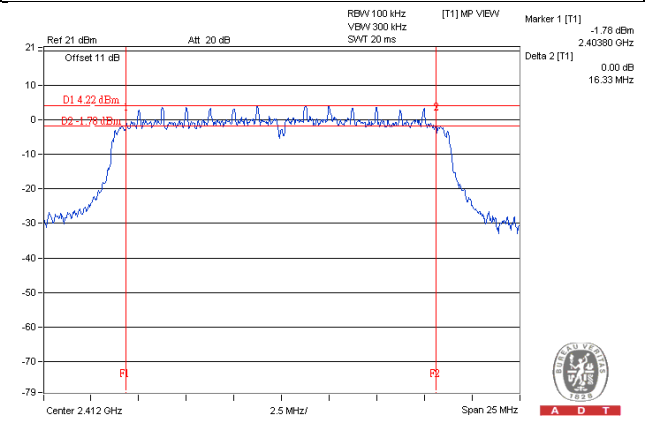
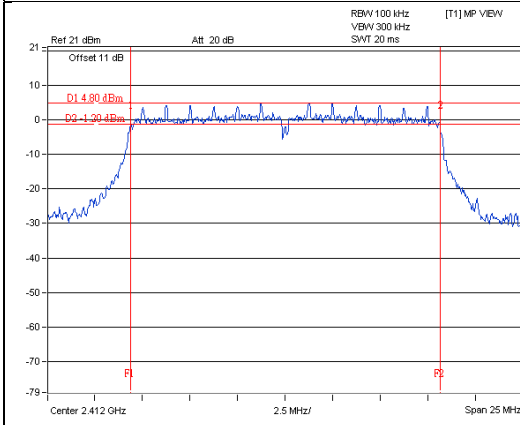

4.4 Conducted Output Power Measurement

4.4.1 Limits of Conducted Output Power Measurement

For systems using digital modulation in the 2400–2483.5 MHz bands: 1 Watt (30dBm)

4.4.2 Test Setup

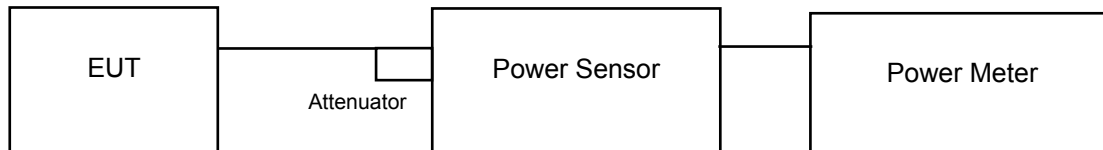

4.4.3 Test Instruments

DESCRIPTION & MANUFACTURER	MODEL NO.	SERIAL NO.	CALIBRATED DATE	CALIBRATED UNTIL
Power Meter Anritsu	ML2495A	1014008	Apr. 30, 2014	Apr. 29, 2015
Power Sensor Anritsu	MA2411B	0917122	Apr. 30, 2014	Apr. 29, 2015

- NOTE:**
1. The test was performed in Oven room B.
 2. The calibration interval of the above test instruments is 12 months and the calibrations are traceable to NML/ROC and NIST/USA.
 3. Tested Date: Jan. 22, 2015

4.4.4 Test Procedures

A peak / average power sensor was used on the output port of the EUT. A power meter was used to read the response of the peak / average power sensor. Record the power level.

4.4.5 Deviation from Test Standard

No deviation.

4.4.6 EUT Operating Conditions

Same as Item 4.3.6.

4.4.7 Test Results

FOR PEAK POWER

802.11g

CHANNEL	FREQUENCY (MHz)	PEAK POWER (mW)	PEAK POWER (dBm)	LIMIT (dBm)	PASS/FAIL
1	2412	218.273	23.39	30	PASS
6	2437	304.789	24.84	30	PASS
11	2462	293.765	24.68	30	PASS

802.11n (HT20)

CHANNEL	FREQUENCY (MHz)	PEAK POWER (mW)	PEAK POWER (dBm)	LIMIT (dBm)	PASS/FAIL
1	2412	247.742	23.94	30	PASS
6	2437	278.612	24.45	30	PASS
11	2462	276.058	24.41	30	PASS

FOR AVERAGE POWER

802.11g

CHANNEL	FREQUENCY (MHz)	AVERAGE POWER (mW)	AVERAGE POWER (dBm)
1	2412	33.343	15.23
6	2437	46.238	16.65
11	2462	44.157	16.45

802.11n (HT20)

CHANNEL	FREQUENCY (MHz)	AVERAGE POWER (mW)	AVERAGE POWER (dBm)
1	2412	36.644	15.64
6	2437	46.132	16.64
11	2462	42.954	16.33

4.5 Power Spectral Density Measurement

4.5.1 Limits of Power Spectral Density Measurement

The Maximum of Power Spectral Density Measurement is 8dBm.

4.5.2 Test Setup

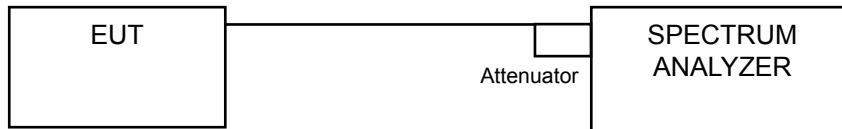

4.5.3 Test Instruments

DESCRIPTION & MANUFACTURER	MODEL NO.	SERIAL NO.	CALIBRATED DATE	CALIBRATED UNTIL
SPECTRUM ANALYZER R&S	FSP 40	100060	May 08, 2014	May 07, 2015

- NOTE:**
1. The test was performed in Oven room B.
 2. The calibration interval of the above test instruments is 12 months and the calibrations are traceable to NML/ROC and NIST/USA.
 3. Tested Date: Jan. 22, 2015

4.5.4 Test Procedure

- a) Set analyzer center frequency to DTS channel center frequency.
- b) Set the span to 1.5 times the DTS bandwidth.
- c) Set the RBW to: $3 \text{ kHz} \leq \text{RBW} \leq 100 \text{ kHz}$.
- d) Set the VBW $\geq 3 \times \text{RBW}$.
- e) Detector = peak.
- f) Sweep time = auto couple.
- g) Trace mode = max hold.
- h) Allow trace to fully stabilize.
- i) Use the peak marker function to determine the maximum amplitude level within the RBW.

4.5.5 Deviation from Test Standard

No deviation.

4.5.6 EUT Operating Condition

Same as Item 4.3.6

4.5.7 Test Results

802.11g

Channel	Freq. (MHz)	PSD (dBm/3kHz)	Limit (dBm/3kHz)	PASS /FAIL
1	2412	-10.13	8	PASS
6	2437	-8.97	8	PASS
11	2462	-10.37	8	PASS

802.11n (HT20)

Channel	Freq. (MHz)	PSD (dBm/3kHz)	Limit (dBm/3kHz)	PASS /FAIL
1	2412	-10.92	8	PASS
6	2437	-9.96	8	PASS
11	2462	-10.01	8	PASS

SPECTRUM PLOT OF WORST VALUE

802.11g / CH6

802.11n (HT20) / CH6

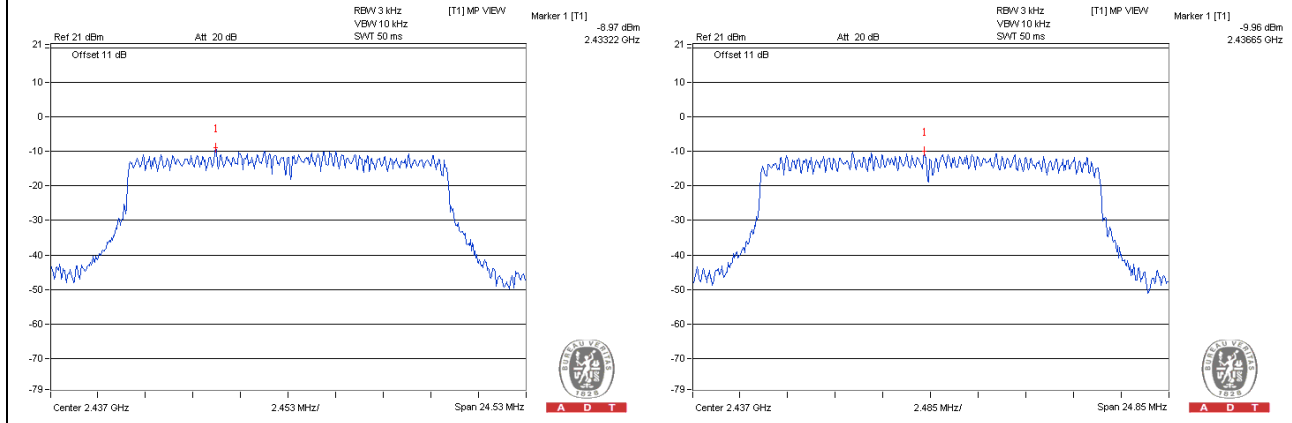

4.6 Conducted Out of Band Emission Measurement

4.6.1 Limits of Conducted Out of Band Emission Measurement

Below -20dB of the highest emission level of operating band (in 100kHz Resolution Bandwidth).

4.6.2 Test Setup

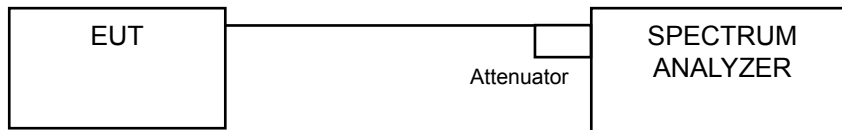

4.6.3 Test Instruments

DESCRIPTION & MANUFACTURER	MODEL NO.	SERIAL NO.	CALIBRATED DATE	CALIBRATED UNTIL
SPECTRUM ANALYZER R&S	FSP 40	100060	May 08, 2014	May 07, 2015

- NOTE:**
1. The test was performed in Oven room B.
 2. The calibration interval of the above test instruments is 12 months and the calibrations are traceable to NML/ROC and NIST/USA.
 3. Tested Date: Jan. 22, 2015

4.6.4 Test Procedure

MEASUREMENT PROCEDURE REF

1. Set the RBW = 100 kHz.
2. Set the VBW ≥ 300 kHz.
3. Detector = peak.
4. Sweep time = auto couple.
5. Trace mode = max hold.
6. Allow trace to fully stabilize.
7. Use the peak marker function to determine the maximum power level in any 100 kHz band segment within the fundamental EBW.

MEASUREMENT PROCEDURE OOBE

1. Set RBW = 100 kHz.
2. Set VBW ≥ 300 kHz.
3. Ensure that the number of measurement points ≥ span/RBW
4. According to measurement points to set differ measurement span.
5. Detector = peak.
6. Trace Mode = max hold.
7. Sweep = auto couple.

4.6.5 Deviation from Test Standard

No deviation.

4.6.6 EUT Operating Condition

Same as Item 4.3.6

4.6.7 Test Results

The spectrum plots are attached on the following pages. D1 line indicates the highest level, and D2 line indicates the 20dB offset below D1. It shows compliance with the requirement.

802.11g

CH 1

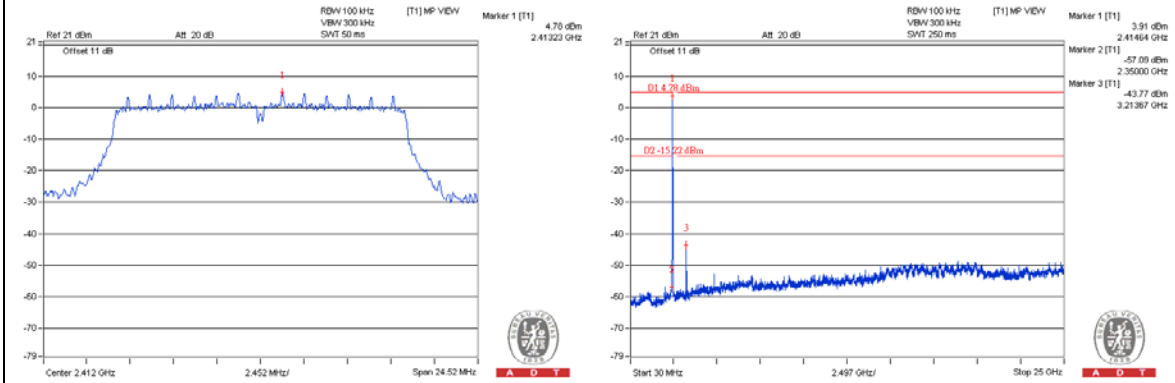

CH 6

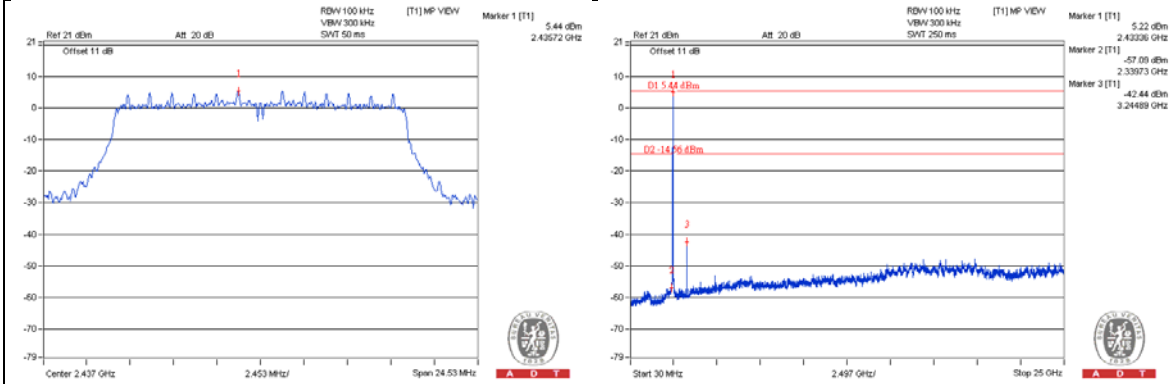

CH 11

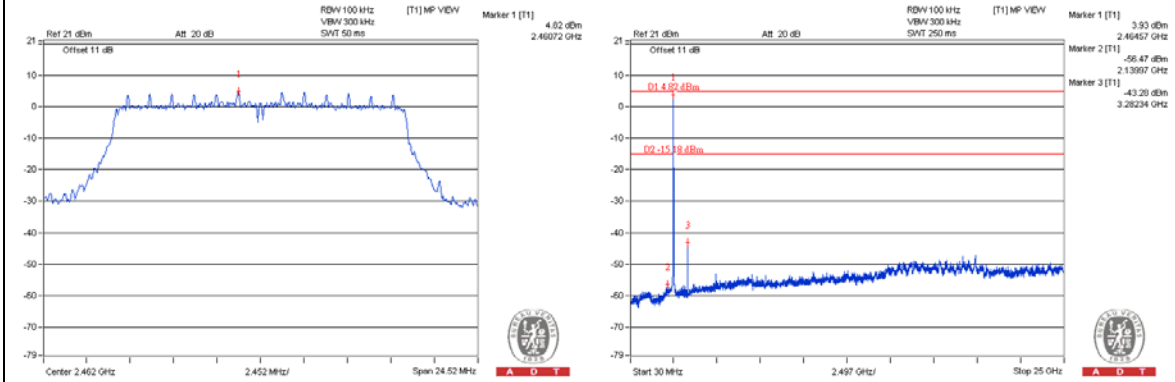

CH 1 Band edge

CH 11 Band edge

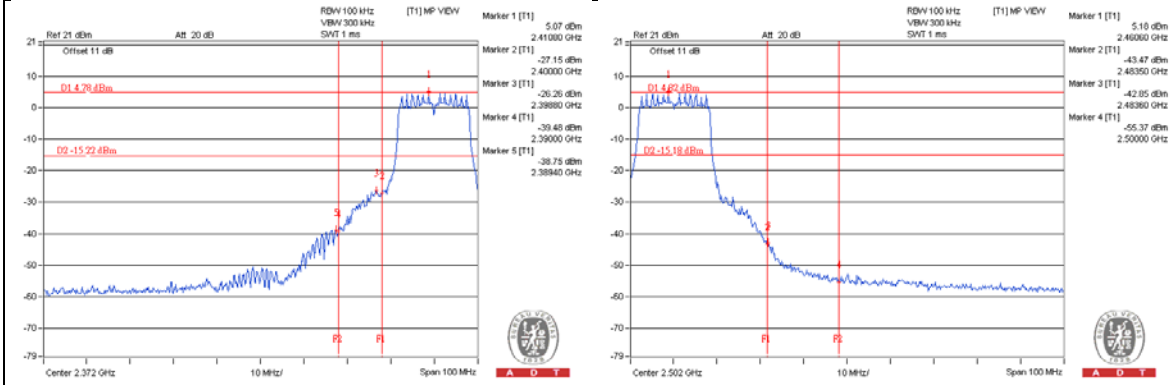

802.11n (HT20)

CH 1

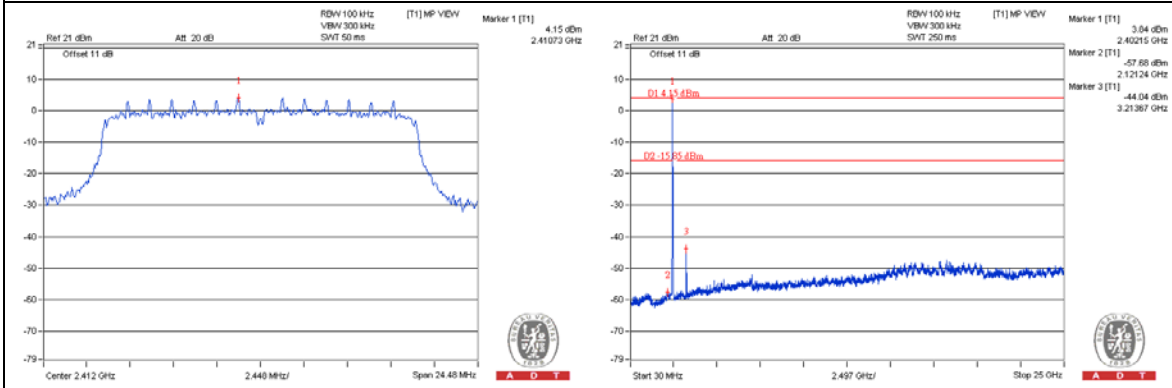

CH 6

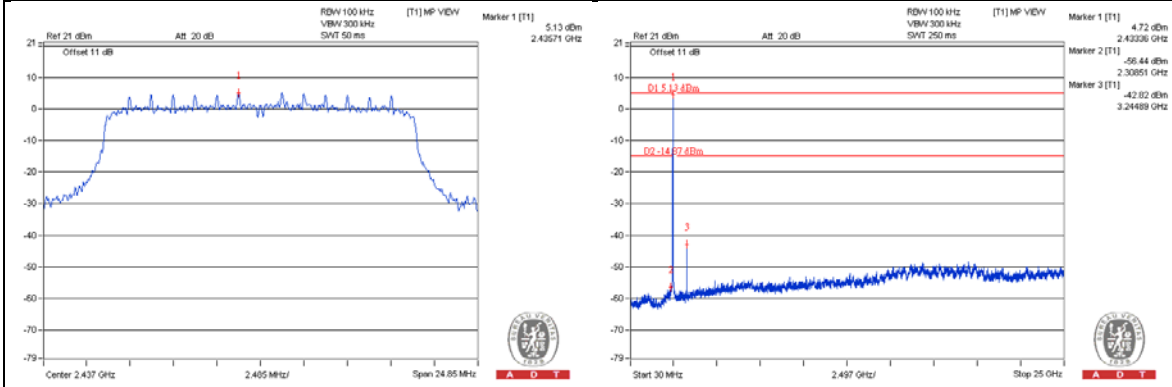

CH 11

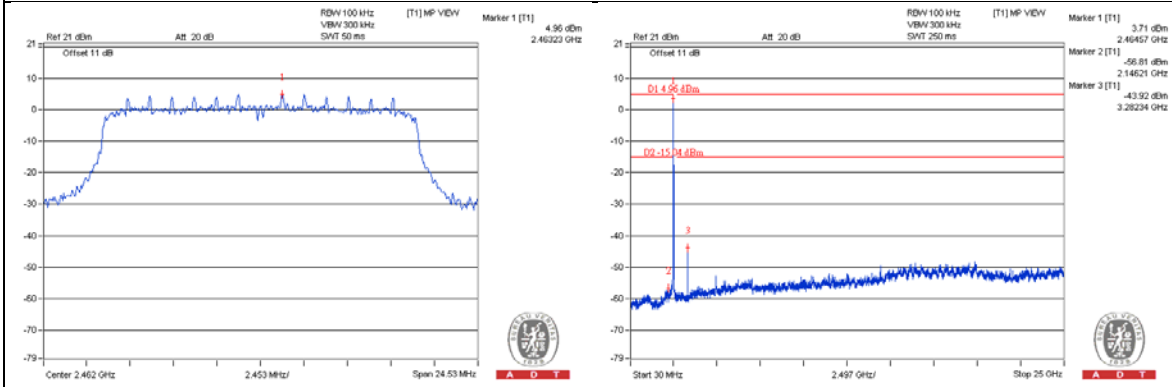

CH 1 Band edge

CH 11 Band edge

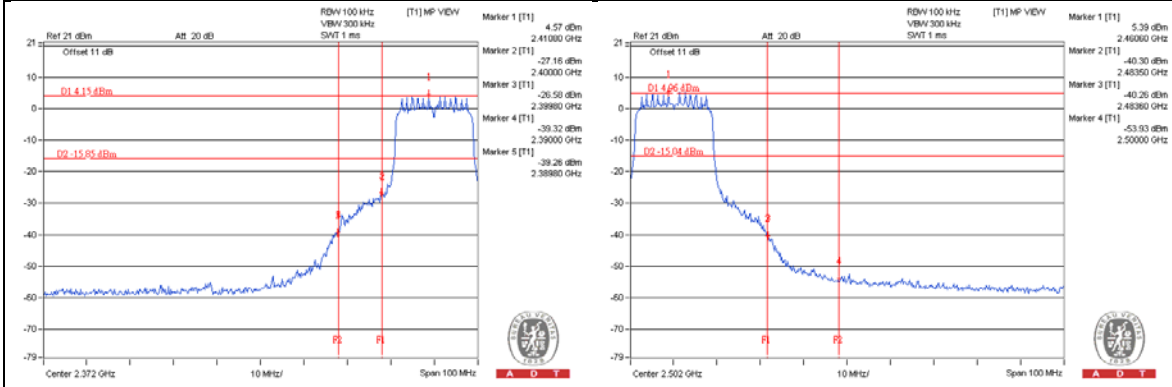

5 Pictures of Test Arrangements

Please refer to the attached file (Test Setup Photo).



Appendix – Information on the Testing Laboratories

We, Bureau Veritas Consumer Products Services (H.K.) Ltd., Taoyuan Branch, were founded in 1988 to provide our best service in EMC, Radio, Telecom and Safety consultation. Our laboratories are accredited and approved according to ISO/IEC 17025.

If you have any comments, please feel free to contact us at the following:

Linko EMC/RF Lab

Tel: 886-2-26052180

Fax: 886-2-26051924

Hsin Chu EMC/RF Lab/Telecom Lab

Tel: 886-3-5935343

Fax: 886-3-5935342

Hwa Ya EMC/RF/Safety

Tel: 886-3-3183232

Fax: 886-3-3270892

Email: service.adt@tw.bureauveritas.com

Web Site: www.bureauveritas-adt.com

The address and road map of all our labs can be found in our web site also.

--- END ---