

# PCTEST ENGINEERING LABORATORY, INC.

**DUT: JNZS00166; Type: Portable Speaker; Serial: 0561**

Communication System: UID 0, IEEE 802.11b; Frequency: 2437 MHz; Duty Cycle: 1:1  
Medium: 2450 Body Medium parameters used (interpolated):  
 $f = 2437 \text{ MHz}$ ;  $\sigma = 1.929 \text{ S/m}$ ;  $\epsilon_r = 51.938$ ;  $\rho = 1000 \text{ kg/m}^3$   
Phantom section: Flat Section; Space: 1.0 cm

Test Date: 07-17-2017; Ambient Temp: 20.8°C; Tissue Temp: 22.0°C

Probe: EX3DV4 - SN7406; ConvF(7.6, 7.6, 7.6); Calibrated: 4/18/2017;  
Sensor-Surface: 1.4mm (Mechanical Surface Detection)  
Electronics: DAE4 Sn1407; Calibrated: 4/11/2017

Phantom: SAM Right; Type: QD000P40CD; Serial: TP:7535  
Measurement SW: DASY52, Version 52.10; SEMCAD X Version 14.6.10 (7417)

**Mode: IEEE 802.11b, 22 MHz Bandwidth, Body SAR,  
Ch 06, 1 Mbps, Side, Chain0**

**Area Scan (10x21x1):** Measurement grid:  $dx=12\text{mm}$ ,  $dy=12\text{mm}$

**Zoom Scan (7x7x7)/Cube 0:** Measurement grid:  $dx=5\text{mm}$ ,  $dy=5\text{mm}$ ,  $dz=5\text{mm}$

Reference Value = 13.77 V/m; Power Drift = -0.14 dB

Peak SAR (extrapolated) = 0.658 W/kg

**SAR(1 g) = 0.335 W/kg**

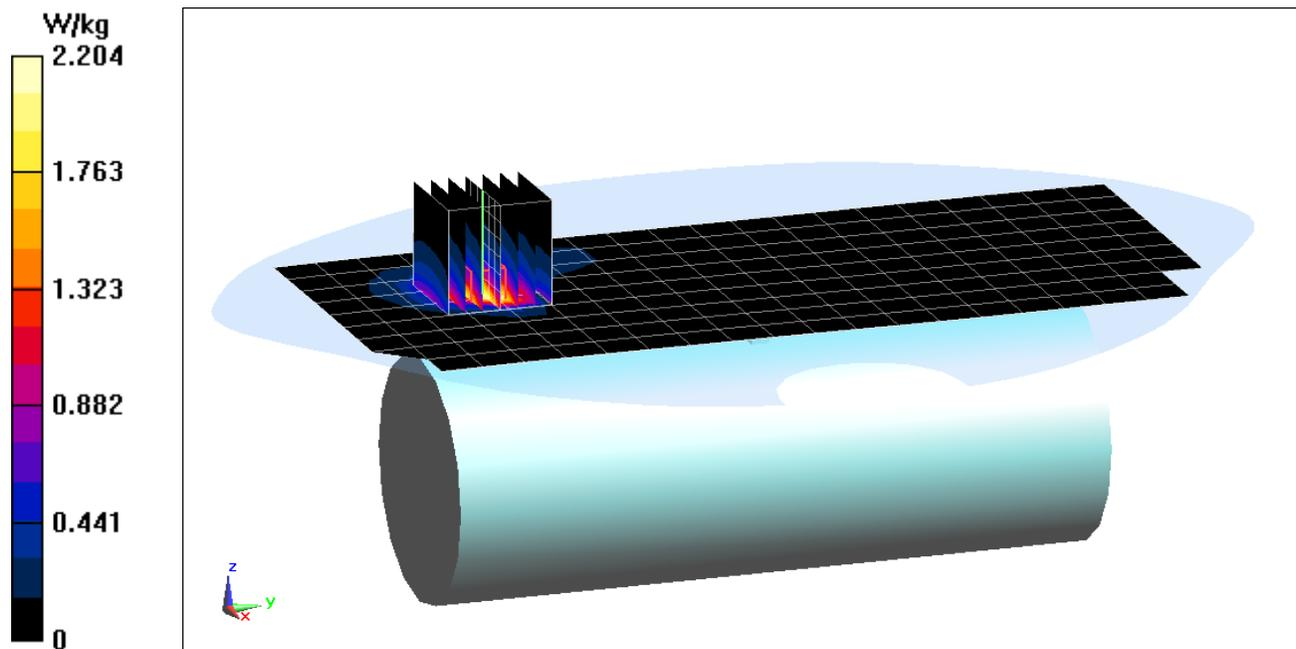

# PCTEST ENGINEERING LABORATORY, INC.

**DUT: JNZS00166; Type: Portable Speaker; Serial: 0561**

Communication System: UID 0, 802.11a 5.2-5.8 GHz Band; Frequency: 5200 MHz; Duty Cycle: 1:1

Medium: 5 GHz Body Medium parameters used:

$f = 5200 \text{ MHz}$ ;  $\sigma = 5.393 \text{ S/m}$ ;  $\epsilon_r = 47.833$ ;  $\rho = 1000 \text{ kg/m}^3$

Phantom section: Flat Section; Space: 1.0 cm

Test Date: 07-17-2017; Ambient Temp: 22.1°C; Tissue Temp: 21.0°C

Probe: EX3DV4 - SN3589; ConvF(4.19, 4.19, 4.19); Calibrated: 1/13/2017;

Sensor-Surface: 1.4mm (Mechanical Surface Detection)

Electronics: DAE4 Sn1466; Calibrated: 1/16/2017

Phantom: SAM with CRP v5.0 Front; Type: QD000P40CD; Serial: 1646

Measurement SW: DASY52, Version 52.10; SEMCAD X Version 14.6.10 (7417)

**Mode: IEEE 802.11a, UNII-1, 20 MHz Bandwidth, Body SAR,  
Ch 40, 6 Mbps, Side, Chain1**

**Area Scan (13x23x1):** Measurement grid: dx=10mm, dy=10mm

**Zoom Scan (7x7x7)/Cube 0:** Measurement grid: dx=4mm, dy=4mm, dz=1.4mm; Graded Ratio: 1.4

Reference Value = 6.296 V/m; Power Drift = -0.21 dB

Peak SAR (extrapolated) = 1.39 W/kg

**SAR(1 g) = 0.202 W/kg**

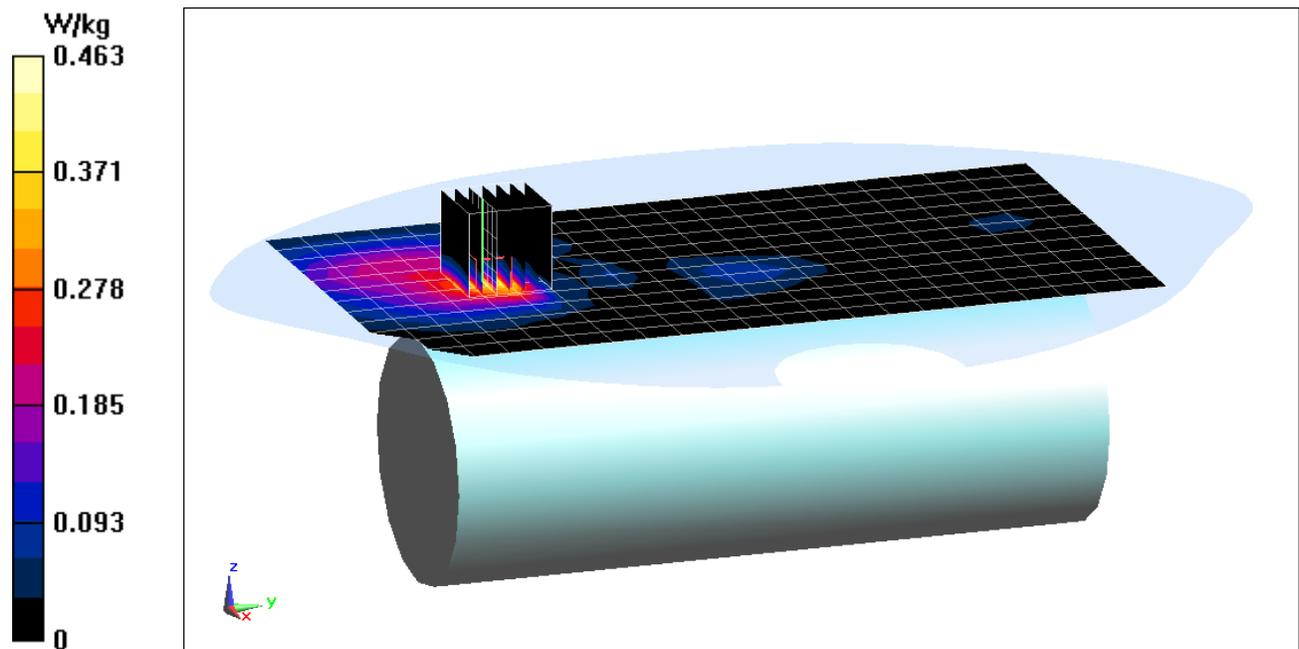

# PCTEST ENGINEERING LABORATORY, INC.

**DUT: JNZS00166; Type: Portable Speaker; Serial: 0561**

Communication System: UID 0, Bluetooth; Frequency: 2480 MHz; Duty Cycle: 1:1.634

Medium: 2450 Body Medium parameters used (interpolated):

$f = 2480$  MHz;  $\sigma = 1.988$  S/m;  $\epsilon_r = 51.766$ ;  $\rho = 1000$  kg/m<sup>3</sup>

Phantom section: Flat Section; Space: 1.0 cm

Test Date: 07-17-2017; Ambient Temp: 20.8°C; Tissue Temp: 22.0°C

Probe: EX3DV4 - SN7406; ConvF(7.6, 7.6, 7.6); Calibrated: 4/18/2017;

Sensor-Surface: 1.4mm (Mechanical Surface Detection)

Electronics: DAE4 Sn1407; Calibrated: 4/11/2017

Phantom: SAM Right; Type: QD000P40CD; Serial: TP:7535

Measurement SW: DASY52, Version 52.10; SEMCAD X Version 14.6.10 (7417)

**Mode: Bluetooth LE, Body SAR, Ch 39, 1 Mbps, Side**

**Area Scan (10x24x1):** Measurement grid: dx=12mm, dy=12mm

**Zoom Scan (7x7x7)/Cube 0:** Measurement grid: dx=5mm, dy=5mm, dz=5mm

Reference Value = 2.499 V/m; Power Drift = -0.18 dB

Peak SAR (extrapolated) = 0.0210 W/kg

**SAR(1 g) = 0.012 W/kg**

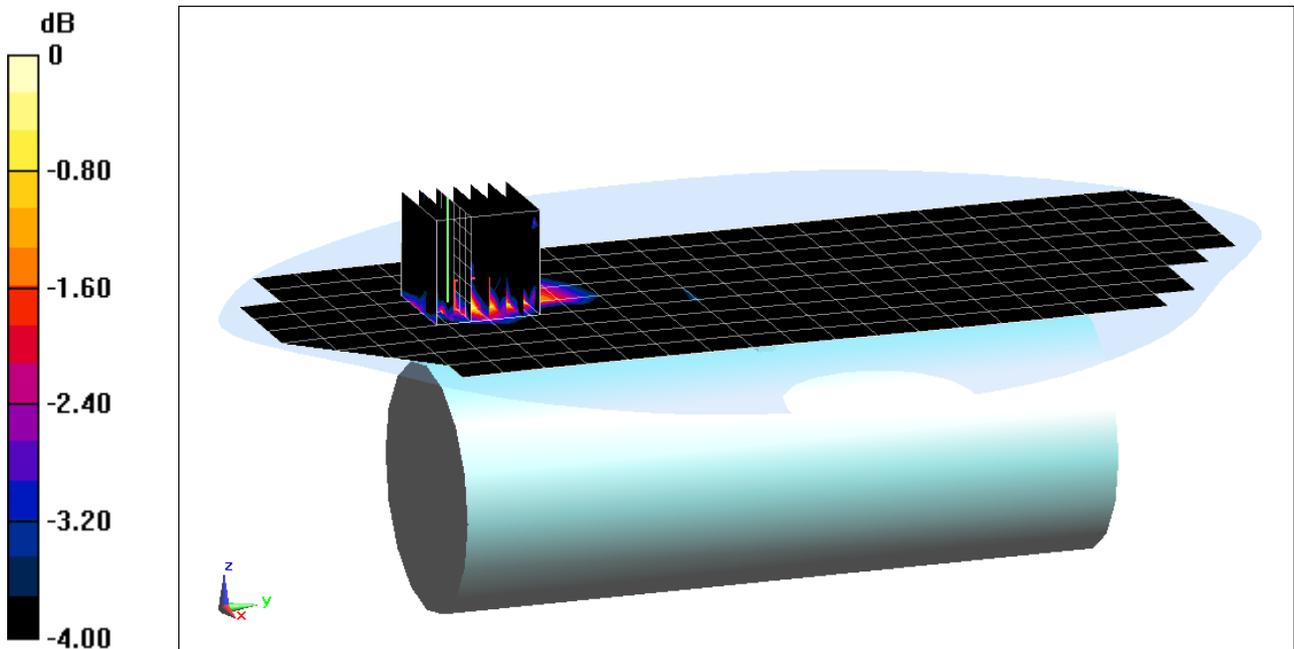

0 dB = 0.0190 W/kg = -17.21 dBW/kg

# PCTEST ENGINEERING LABORATORY, INC.

**DUT: JNZS00166; Type: Portable Speaker; Serial: 0561**

Communication System: UID 0, IEEE 802.11b; Frequency: 2437 MHz; Duty Cycle: 1:1  
Medium: 2450 Body Medium parameters used (interpolated):  
 $f = 2437 \text{ MHz}$ ;  $\sigma = 1.929 \text{ S/m}$ ;  $\epsilon_r = 51.938$ ;  $\rho = 1000 \text{ kg/m}^3$   
Phantom section: Flat Section; Space: 0.0 cm

Test Date: 07-17-2017; Ambient Temp: 20.8°C; Tissue Temp: 22.0°C

Probe: EX3DV4 - SN7406; ConvF(7.6, 7.6, 7.6); Calibrated: 4/18/2017;  
Sensor-Surface: 1.4mm (Mechanical Surface Detection)  
Electronics: DAE4 Sn1407; Calibrated: 4/11/2017

Phantom: SAM Right; Type: QD000P40CD; Serial: TP:7535  
Measurement SW: DASY52, Version 52.10; SEMCAD X Version 14.6.10 (7417)

**Mode: IEEE 802.11b, 22 MHz Bandwidth, Extremity SAR,  
Ch 06, 1 Mbps, Side, Chain0**

**Area Scan (10x21x1):** Measurement grid: dx=12mm, dy=12mm

**Zoom Scan (7x7x7)/Cube 0:** Measurement grid: dx=5mm, dy=5mm, dz=5mm

Reference Value = 27.45 V/m; Power Drift = 0.18 dB

Peak SAR (extrapolated) = 3.57 W/kg

**SAR(10 g) = 0.608 W/kg**

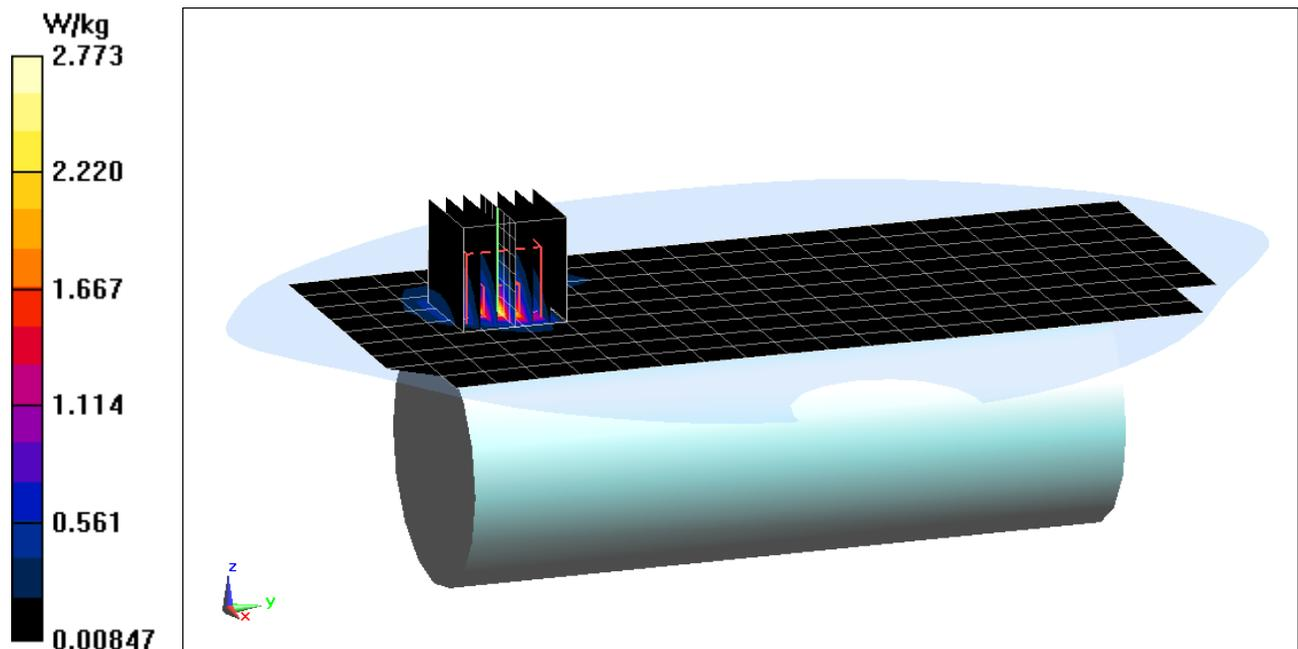

# PCTEST ENGINEERING LABORATORY, INC.

**DUT: JNZS00166; Type: Portable Speaker; Serial: 0561**

Communication System: UID 0, 802.11a 5.2-5.8 GHz Band; Frequency: 5200 MHz; Duty Cycle: 1:1

Medium: 5 GHz Body Medium parameters used:

$f = 5200$  MHz;  $\sigma = 5.393$  S/m;  $\epsilon_r = 47.833$ ;  $\rho = 1000$  kg/m<sup>3</sup>

Phantom section: Flat Section; Space: 0.0 cm

Test Date: 07-17-2017; Ambient Temp: 22.1°C; Tissue Temp: 21.0°C

Probe: EX3DV4 - SN3589; ConvF(4.19, 4.19, 4.19); Calibrated: 1/13/2017;

Sensor-Surface: 1.4mm (Mechanical Surface Detection)

Electronics: DAE4 Sn1466; Calibrated: 1/16/2017

Phantom: SAM with CRP v5.0 Front; Type: QD000P40CD; Serial: 1646

Measurement SW: DASY52, Version 52.10; SEMCAD X Version 14.6.10 (7417)

**Mode: IEEE 802.11a, UNII-1, 20 MHz Bandwidth, Extremity SAR,  
Ch 40, 6 Mbps, Side, Chain1**

**Area Scan (11x22x1):** Measurement grid: dx=10mm, dy=10mm

**Zoom Scan (8x8x7)/Cube 0:** Measurement grid: dx=4mm, dy=4mm, dz=1.4mm; Graded Ratio: 1.4

Reference Value = 16.86 V/m; Power Drift = 0.02 dB

Peak SAR (extrapolated) = 6.03 W/kg

**SAR(10 g) = 0.416 W/kg**

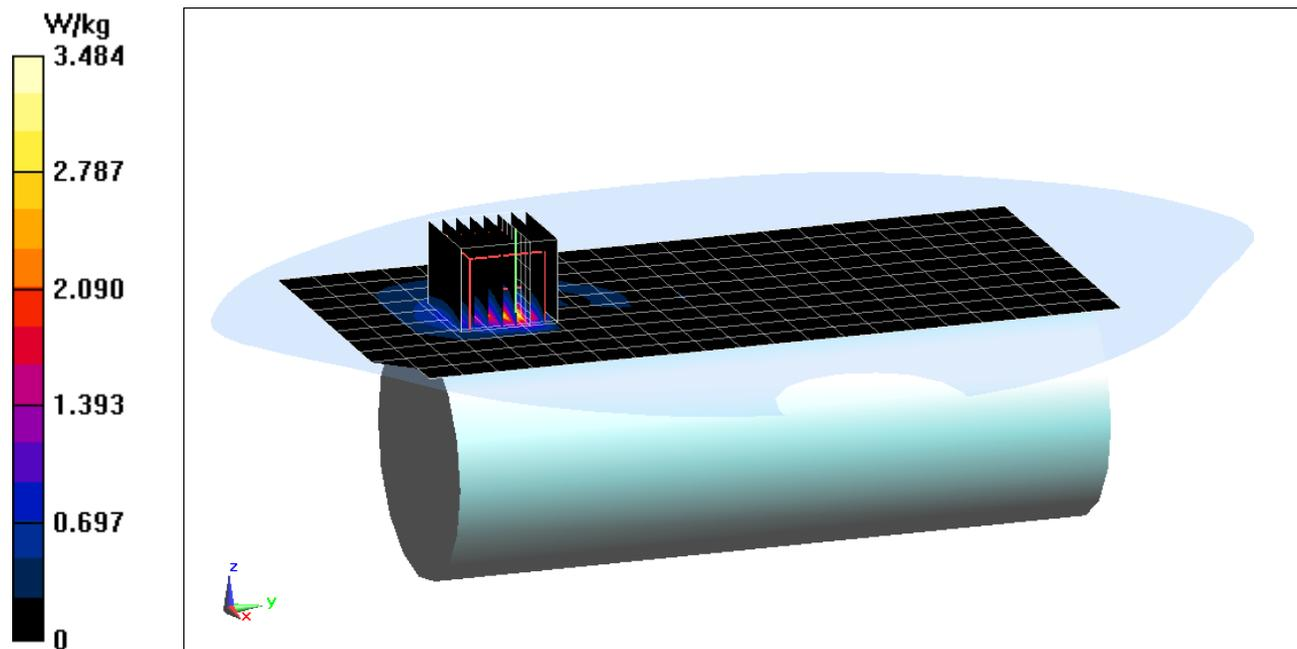

# PCTEST ENGINEERING LABORATORY, INC.

**DUT: JNZS00166; Type: Portable Speaker; Serial: 0561**

Communication System: UID 0, Bluetooth; Frequency: 2480 MHz; Duty Cycle: 1:1.634

Medium: 2450 Body Medium parameters used (interpolated):

$f = 2480$  MHz;  $\sigma = 1.988$  S/m;  $\epsilon_r = 51.766$ ;  $\rho = 1000$  kg/m<sup>3</sup>

Phantom section: Flat Section; Space: 0.0 cm

Test Date: 07-17-2017; Ambient Temp: 20.8°C; Tissue Temp: 22.0°C

Probe: EX3DV4 - SN7406; ConvF(7.6, 7.6, 7.6); Calibrated: 4/18/2017;

Sensor-Surface: 1.4mm (Mechanical Surface Detection)

Electronics: DAE4 Sn1407; Calibrated: 4/11/2017

Phantom: SAM Right; Type: QD000P40CD; Serial: TP:7535

Measurement SW: DASY52, Version 52.10;SEMCAD X Version 14.6.10 (7417)

**Mode: Bluetooth LE, Extremity SAR, Ch 39, 1 Mbps, Side**

**Area Scan (10x24x1):** Measurement grid: dx=12mm, dy=12mm

**Zoom Scan (9x9x7)/Cube 0:** Measurement grid: dx=5mm, dy=5mm, dz=5mm

Reference Value = 3.734 V/m; Power Drift = 0.17 dB

Peak SAR (extrapolated) = 0.0620 W/kg

**SAR(10 g) = 0.016 W/kg**

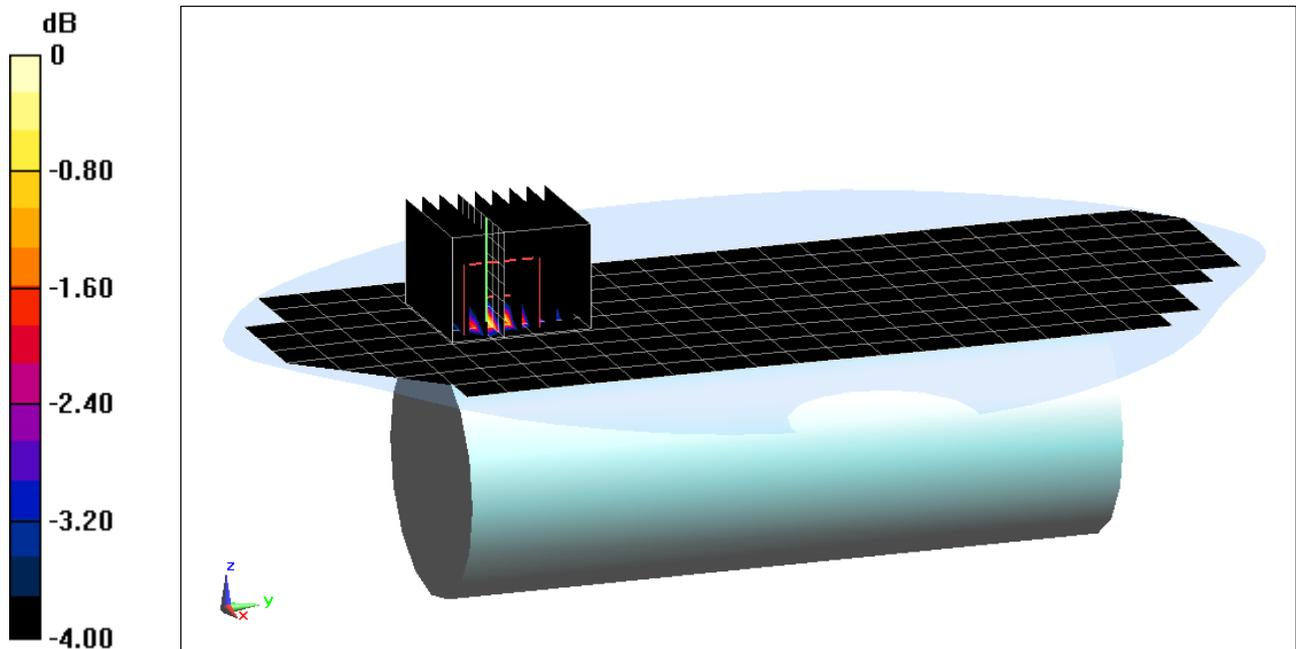

0 dB = 0.0488 W/kg = -13.12 dBW/kg