



FCC TEST REPORT(Bluetooth)

REPORT NO.: RF130218E12

MODEL NO.: S-00122

FCC ID: JNZS00122

RECEIVED: Feb. 18, 2013

TESTED: Feb. 20 to 23, 2013

ISSUED: Mar. 08, 2013

APPLICANT: LOGITECH FAR EAST LTD.

ADDRESS: #2 Creation Rd. 4, Science-Based Ind. Park Hsinchu
Taiwan, R.O.C.

ISSUED BY: Bureau Veritas Consumer Products Services (H.K.)
Ltd., Taoyuan Branch Hsin Chu Laboratory

LAB ADDRESS: No. 81-1, Lu Liao Keng, 9th Ling,Wu Lung Tsuen,
Chiung Lin Hsiang, Hsin Chu Hsien 307, Taiwan,
R.O.C.

TEST LOCATION (1): No. 81-1, Lu Liao Keng, 9th Ling,Wu Lung Tsuen,
Chiung Lin Hsiang, Hsin Chu Hsien 307, Taiwan,
Taiwan, R.O.C.

TEST LOCATION (2): No.49, Ln. 206, Wende Rd., Shangshan Tsuen,
Chiung Lin Hsiang, Hsin Chu Hsien 307, Taiwan,
Taiwan, R.O.C.

This report should not be used by the client to claim product certification, approval, or endorsement by TAF or any government agencies.



This report is for your exclusive use. Any copying or replication of this report to or for any other person or entity, or use of our name or trademark, is permitted only with our prior written permission. This report sets forth our findings solely with respect to the test samples identified herein. The results set forth in this report are not indicative or representative of the quality or characteristics of the lot from which a test sample was taken or any similar or identical product unless specifically and expressly noted. Our report includes all of the tests requested by you and the results thereof based upon the information that you provided to us. You have 60 days from date of issuance of this report to notify us of any material error or omission caused by our negligence, provided, however, that such notice shall be in writing and shall specifically address the issue you wish to raise. A failure to raise such issue within the prescribed time shall constitute your unqualified acceptance of the completeness of this report, the tests conducted and the correctness of the report contents. Unless specific mention, the uncertainty of measurement has been explicitly taken into account to declare the compliance or non-compliance to the specification



TABLE OF CONTENTS

| | |
|--|----|
| RELEASE CONTROL RECORD | 4 |
| 1 CERTIFICATION | 5 |
| 2 SUMMARY OF TEST RESULTS | 6 |
| 2.1 MEASUREMENT UNCERTAINTY | 7 |
| 3 GENERAL INFORMATION | 8 |
| 3.1 GENERAL DESCRIPTION OF EUT | 8 |
| 3.2 DESCRIPTION OF TEST MODES | 10 |
| 3.3 TEST MODE APPLICABILITY AND TESTED CHANNEL DETAIL: | 11 |
| 3.4 GENERAL DESCRIPTION OF APPLIED STANDARDS | 13 |
| 3.5 DESCRIPTION OF SUPPORT UNITS | 14 |
| 3.6 CONFIGURATION OF SYSTEM UNDER TEST | 15 |
| 4 TEST PROCEDURES AND RESULTS | 16 |
| 4.1 CONDUCTED EMISSION MEASUREMENT | 16 |
| 4.1.1 LIMITS OF CONDUCTED EMISSION MEASUREMENT | 16 |
| 4.1.2 TEST INSTRUMENTS | 16 |
| 4.1.3 TEST PROCEDURES | 17 |
| 4.1.4 DEVIATION FROM TEST STANDARD | 17 |
| 4.1.5 TEST SETUP | 18 |
| 4.1.6 EUT OPERATING CONDITIONS | 18 |
| 4.1.7 TEST RESULTS(MODE 1) | 19 |
| 4.1.8 TEST RESULTS(MODE 2) | 21 |
| 4.2 RADIATED EMISSION AND BANDEDGE MEASUREMENT | 23 |
| 4.2.1 LIMITS OF RADIATED EMISSION AND BANDEDGE MEASUREMENT | 23 |
| 4.2.2 TEST INSTRUMENTS | 24 |
| 4.2.3 TEST PROCEDURES | 26 |
| 4.2.4 DEVIATION FROM TEST STANDARD | 26 |
| 4.2.5 TEST SETUP | 27 |
| 4.2.6 EUT OPERATING CONDITIONS | 27 |
| 4.2.7 TEST RESULTS | 28 |
| 4.3 NUMBER OF HOPPING FREQUENCY USED | 35 |
| 4.3.1 LIMIT OF HOPPING FREQUENCY USED | 35 |
| 4.3.2 TEST INSTRUMENTS | 35 |
| 4.3.3 TEST PROCEDURES | 35 |
| 4.3.4 DEVIATION FROM TEST STANDARD | 35 |
| 4.3.5 TEST SETUP | 36 |
| 4.3.6 TEST RESULTS | 36 |
| 4.4 DWELL TIME ON EACH CHANNEL | 37 |
| 4.4.1 LIMIT OF DWELL TIME USED | 37 |
| 4.4.2 TEST INSTRUMENTS | 37 |
| 4.4.3 TEST PROCEDURES | 37 |
| 4.4.4 DEVIATION FROM TEST STANDARD | 38 |
| 4.4.5 TEST SETUP | 38 |
| 4.4.6 TEST RESULTS | 39 |



A D T

| | | |
|-------|---|----|
| 4.5 | CHANNEL BANDWIDTH | 43 |
| 4.5.1 | LIMITS OF CHANNEL BANDWIDTH..... | 43 |
| 4.5.2 | TEST INSTRUMENTS | 43 |
| 4.5.3 | TEST PROCEDURE | 43 |
| 4.5.4 | DEVIATION FROM TEST STANDARD..... | 43 |
| 4.5.5 | TEST SETUP | 44 |
| 4.5.6 | EUT OPERATING CONDITION..... | 44 |
| 4.5.7 | TEST RESULTS..... | 45 |
| 4.6 | HOPPING CHANNEL SEPARATION..... | 46 |
| 4.6.1 | LIMIT OF HOPPING CHANNEL SEPARATION..... | 46 |
| 4.6.2 | TEST INSTRUMENTS | 46 |
| 4.6.3 | TEST PROCEDURES..... | 46 |
| 4.6.4 | DEVIATION FROM TEST STANDARD..... | 46 |
| 4.6.5 | TEST SETUP | 46 |
| 4.6.6 | TEST RESULTS..... | 47 |
| 4.7 | MAXIMUM PEAK OUTPUT POWER..... | 48 |
| 4.7.1 | LIMITS OF MAXIMUM PEAK OUTPUT POWER MEASUREMENT..... | 48 |
| 4.7.2 | INSTRUMENTS | 48 |
| 4.7.3 | TEST PROCEDURES..... | 48 |
| 4.7.4 | DEVIATION FROM TEST STANDARD..... | 48 |
| 4.7.5 | TEST SETUP | 49 |
| 4.7.6 | EUT OPERATING CONDITION..... | 49 |
| 4.7.7 | TEST RESULTS..... | 50 |
| 4.8 | CONDUCTED OUT-BAND EMISSION MEASUREMENT..... | 51 |
| 4.8.1 | LIMITS OF CONDUCTED OUT-BAND EMISSION MEASUREMENT..... | 51 |
| 4.8.2 | TEST INSTRUMENTS | 51 |
| 4.8.3 | TEST PROCEDURE | 51 |
| 4.8.4 | DEVIATION FROM TEST STANDARD..... | 51 |
| 4.8.5 | TEST SETUP | 51 |
| 4.8.6 | EUT OPERATING CONDITION..... | 51 |
| 4.8.7 | TEST RESULTS..... | 52 |
| 5 | PHOTOGRAPHS OF THE TEST CONFIGURATION..... | 55 |
| 6 | INFORMATION ON THE TESTING LABORATORIES | 56 |
| 7 | APPENDIX A - MODIFICATIONS RECORDERS FOR ENGINEERING CHANGES TO THE EUT BY THE LAB..... | 57 |



RELEASE CONTROL RECORD

| ISSUE NO. | REASON FOR CHANGE | DATE ISSUED |
|-------------|-------------------|---------------|
| RF130218E12 | Original release | Mar. 08, 2013 |



1 CERTIFICATION

PRODUCT : Wireless Speaker
BRAND NAME : Ue, Logitech | Ue, Logitech
MODEL NO. : S-00122
TEST SAMPLE : ENGINEERING SAMPLE
APPLICANT : LOGITECH FAR EAST LTD.
TESTED DATE : Feb. 20 to 23, 2013
STANDARDS : **FCC Part 15, Subpart C (Section 15.247)**
ANSI C63.10-2009

The above equipment (Model: S-00122) has been tested by **Bureau Veritas Consumer Products Services (H.K.) Ltd., Taoyuan Branch**, and found compliance with the requirement of the above standards. The test record, data evaluation & Equipment Under Test (EUT) configurations represented herein are true and accurate accounts of the measurements of the sample's EMC characteristics under the conditions specified in this report.

PREPARED BY :  , **DATE:** Mar. 08, 2013
(Claire Kuan, Specialist)

APPROVED BY :  , **DATE:** Mar. 08, 2013
(May Chen, Deputy Manager)

2 SUMMARY OF TEST RESULTS

The EUT has been tested according to the following specifications:

| APPLIED STANDARD: FCC Part 15, Subpart C | | | |
|--|---|--------|--|
| STANDARD SECTION | TEST TYPE AND LIMIT | RESULT | REMARK |
| 15.207 | AC Power Conducted Emission | PASS | Meet the requirement of limit. Minimum passing margin is -15.91dB at 3.10547MHz. |
| 15.247(a)(1) (iii) | Number of Hopping Frequency Used | PASS | Meet the requirement of limit. |
| 15.247(a)(1) (iii) | Dwell Time on Each Channel | PASS | Meet the requirement of limit. |
| 15.247(a)(1) | 1. Hopping Channel Separation 2. Spectrum Bandwidth of a Frequency Hopping Sequence Spread Spectrum System | PASS | Meet the requirement of limit. |
| 15.247(b) | Maximum Peak Output Power | PASS | Meet the requirement of limit. |
| 15.247(d) | Transmitter Radiated Emissions | PASS | Meet the requirement of limit. Minimum passing margin is -5.9dB at 212.02MHz. |
| 15.247(d) | Band Edge Measurement | PASS | Meet the requirement of limit. |
| 15.203 | Antenna Requirement | PASS | Antenna connector is Wire antenna (dipole) not a standard connector. |

NOTE: Frequency Hopping System operating in 2400-2483.5MHz band and the output power less than 125mW. The hopping channel carrier frequencies separated by a minimum of 25kHz or two-thirds of the 20dB bandwidth of hopping channel whichever is greater.

2.1 MEASUREMENT UNCERTAINTY

Where relevant, the following measurement uncertainty levels have been estimated for tests performed on the EUT as specified in CISPR 16-4-2:

This uncertainty represents an expanded uncertainty expressed at approximately the 95% confidence level using a coverage factor of $k=2$.

| Measurement | Value |
|-----------------------------------|---------|
| Conducted emissions | 2.98 dB |
| Radiated emissions (30MHz-1GHz) | 5.63 dB |
| Radiated emissions (1GHz -6GHz) | 3.54 dB |
| Radiated emissions (6GHz -18GHz) | 4.08 dB |
| Radiated emissions (18GHz -40GHz) | 4.11 dB |

3 GENERAL INFORMATION

3.1 GENERAL DESCRIPTION OF EUT

| | |
|------------------------------|--|
| PRODUCT | Wireless Speaker |
| MODEL NO. | S-00122 |
| POWER SUPPLY | DC 3.6V from battery or DC 5.1V from power adapter DC 5V from host equipment |
| MODULATION TYPE | GFSK, $\pi/4$ -DQPSK, 8DPSK |
| MODULATION TECHNOLOGY | FHSS |
| DATE RATE | Up to 3Mbps |
| FREQUENCY RANGE | 2402MHz ~ 2480MHz |
| NUMBER OF CHANNEL | 79 |
| MAX. OUTPUT POWER | 4.498 mW |
| ANTENNA TYPE | Wire antenna (dipole) with 2.49dBi antenna gain |
| DATA CABLE | USB cable (Shielded, 1.24m) |
| I/O PORTS | Refer to user's manual |
| ASSOCIATED DEVICES | Power adapter x 1 Battery x 1 |

NOTE:

- The EUT has below brand names, which are identical to each other in all aspects except for the following table:

| Brand | Model No. | Difference |
|---------------|-----------|---------------------------|
| Ue | S-00122 | For marketing requirement |
| Logitech Ue | | |
| Logitech | | |

- The EUT must be supplied with a power adapter or battery as following table:

| Adapter | | |
|----------|------------|---|
| Brand | Model No. | Spec. |
| Logitech | AD895320 | AC I/P: 100-240V, 50/60Hz, 0.3A DC O/P: 5.1V, 2.0A |
| Battery | | |
| Brand | L/N | Spec. |
| Logitech | 533-000104 | DC 3.6V, 3200mAh |
| | 533-000105 | |

3. The EUT was pre-tested in chamber under the following modes

| Pre-test Mode | Description |
|---------------|-----------------|
| Mode A | Battery mode |
| Mode B | USB mode |
| Mode C | Adapter mode |

From the above modes, the worst case was found in **Mode B**. Therefore only the test data of the modes were recorded in this report.

4. The above EUT information was declared by manufacturer and for more detailed features description, please refer to the manufacturer's specifications or user's manual.

3.2 DESCRIPTION OF TEST MODES

79 channels are provided for Bluetooth.

| Channel | Freq. (MHz) | Channel | Freq. (MHz) | Channel | Freq. (MHz) | Channel | Freq. (MHz) |
|---------|-------------|---------|-------------|---------|-------------|---------|-------------|
| 0 | 2402 | 20 | 2422 | 40 | 2442 | 60 | 2462 |
| 1 | 2403 | 21 | 2423 | 41 | 2443 | 61 | 2463 |
| 2 | 2404 | 22 | 2424 | 42 | 2444 | 62 | 2464 |
| 3 | 2405 | 23 | 2425 | 43 | 2445 | 63 | 2465 |
| 4 | 2406 | 24 | 2426 | 44 | 2446 | 64 | 2466 |
| 5 | 2407 | 25 | 2427 | 45 | 2447 | 65 | 2467 |
| 6 | 2408 | 26 | 2428 | 46 | 2448 | 66 | 2468 |
| 7 | 2409 | 27 | 2429 | 47 | 2449 | 67 | 2469 |
| 8 | 2410 | 28 | 2430 | 48 | 2450 | 68 | 2470 |
| 9 | 2411 | 29 | 2431 | 49 | 2451 | 69 | 2471 |
| 10 | 2412 | 30 | 2432 | 50 | 2452 | 70 | 2472 |
| 11 | 2413 | 31 | 2433 | 51 | 2453 | 71 | 2473 |
| 12 | 2414 | 32 | 2434 | 52 | 2454 | 72 | 2474 |
| 13 | 2415 | 33 | 2435 | 53 | 2455 | 73 | 2475 |
| 14 | 2416 | 34 | 2436 | 54 | 2456 | 74 | 2476 |
| 15 | 2417 | 35 | 2437 | 55 | 2457 | 75 | 2477 |
| 16 | 2418 | 36 | 2438 | 56 | 2458 | 76 | 2478 |
| 17 | 2419 | 37 | 2439 | 57 | 2459 | 77 | 2479 |
| 18 | 2420 | 38 | 2440 | 58 | 2460 | 78 | 2480 |
| 19 | 2421 | 39 | 2441 | 59 | 2461 | | |



3.3 TEST MODE APPLICABILITY AND TESTED CHANNEL DETAIL:

| EUT CONFIGURE MODE | APPLICABLE TO | | | | | DESCRIPTION |
|--------------------|---------------|---------|---------|------|----|--------------|
| | PLC | RE < 1G | RE ≥ 1G | APCM | OB | |
| 1 | √ | √ | √ | √ | √ | USB MODE |
| 2 | √ | - | - | - | - | ADAPTER MODE |

Where **PLC**: Power Line Conducted Emission **RE < 1G**: Radiated Emission below 1GHz
RE ≥ 1G: Radiated Emission above 1GHz **APCM**: Antenna Port Conducted Measurement
OB: Conducted Out-Band Emission Measurement

NOTE 1: "-" means no effect.

POWER LINE CONDUCTED EMISSION:

- Pre-Scan has been conducted to determine the worst-case mode from all possible combinations between available modulations, data rates and antenna ports (if EUT with antenna diversity architecture).
- Following channel(s) was (were) selected for the final test as listed below.

| Available Channel | Tested Channel | Modulation Technology | Modulation Type | Packet Type |
|-------------------|----------------|-----------------------|-----------------|-------------|
| 0 to 78 | 0 | FHSS | GFSK | DH5 |

RADIATED EMISSION TEST (BELOW 1 GHz):

- Pre-Scan has been conducted to determine the worst-case mode from all possible combinations between available modulations, data rates and antenna ports (if EUT with antenna diversity architecture).
- Following channel(s) was (were) selected for the final test as listed below.

| Available Channel | Tested Channel | Modulation Technology | Modulation Type | Packet Type |
|-------------------|----------------|-----------------------|-----------------|-------------|
| 0 to 78 | 0 | FHSS | GFSK | DH5 |

RADIATED EMISSION TEST (ABOVE 1 GHz):

- Pre-Scan has been conducted to determine the worst-case mode from all possible combinations between available modulations, data rates and antenna ports (if EUT with antenna diversity architecture).
- Following channel(s) was (were) selected for the final test as listed below.

| Available Channel | Tested Channel | Modulation Technology | Modulation Type | Packet Type |
|-------------------|----------------|-----------------------|-----------------|-------------|
| 0 to 78 | 0, 39, 78 | FHSS | GFSK | DH5 |
| 0 to 78 | 0, 39, 78 | FHSS | 8DPSK | DH5 |

ANTENNA PORT CONDUCTED MEASUREMENT:

- Pre-Scan has been conducted to determine the worst-case mode from all possible combinations between available modulations, data rates and antenna ports (if EUT with antenna diversity architecture).
- Following channel(s) was (were) selected for the final test as listed below.

| Available Channel | Tested Channel | Modulation Technology | Modulation Type | Packet Type |
|-------------------|----------------|-----------------------|-----------------|-------------|
| 0 to 78 | 0, 39, 78 | FHSS | GFSK | DH5 |
| 0 to 78 | 0, 39, 78 | FHSS | 8DPSK | DH5 |

CONDUCTED OUT-BAND EMISSION MEASUREMENT:

- Pre-Scan has been conducted to determine the worst-case mode from all possible combinations between available modulations, data rates and antenna ports (if EUT with antenna diversity architecture).
- Following channel(s) was (were) selected for the final test as listed below.

| Available Channel | Tested Channel | Modulation Technology | Modulation Type | Packet Type |
|-------------------|----------------|-----------------------|-----------------|-------------|
| 0 to 78 | 0, 78 | FHSS | GFSK | DH5 |
| 0 to 78 | 0, 78 | FHSS | 8DPSK | DH5 |

TEST CONDITION:

| APPLICABLE TO | ENVIRONMENTAL CONDITIONS | INPUT POWER (SYSTEM) | TESTED BY |
|---------------|--------------------------|----------------------|--------------|
| PLC | 24deg. C, 56%RH | 120Vac, 60Hz | Jason Huang |
| RE<1G | 23deg. C, 65%RH | 120Vac, 60Hz | Robert Cheng |
| RE≥1G | 22deg. C, 73%RH | 120Vac, 60Hz | Robert Cheng |
| APCM | 25deg. C, 60%RH | 120Vac, 60Hz | Robert Cheng |
| OB | 25deg. C, 60%RH | 120Vac, 60Hz | Robert Cheng |



3.4 GENERAL DESCRIPTION OF APPLIED STANDARDS

The EUT is a RF product. According to the specifications of the manufacturer, it must comply with the requirements of the following standards:

FCC Part 15, Subpart C. (15.247)

ANSI C63.10-2009

All test items have been performed and recorded as per the above standards.

NOTE: The EUT is also considered as a kind of computer peripheral, because the connection to computer is necessary for typical use. It has been verified to comply with the requirements of FCC Part 15, Subpart B, Class B (DoC). The test report has been issued separately.

3.5 DESCRIPTION OF SUPPORT UNITS

The EUT has been tested as an independent unit together with other necessary accessories or support units. The following support units or accessories were used to form a representative test configuration during the tests.

| NO. | PRODUCT | BRAND | MODEL NO. | SERIAL NO. | FCC ID |
|-----|----------------------|-------|-----------|---------------|---------|
| 1 | NOTEBOOK COMPUTER | DELL | PP27L | 7YLB32S | FCC DoC |
| 2 | iPod shuffle | APPLE | MC749TA/A | CC4DMFJUJDFDM | FCC DoC |

| NO. | SIGNAL CABLE DESCRIPTION OF THE ABOVE SUPPORT UNITS |
|-----|---|
| 1 | USB cable (1.24m) |
| 2 | USB cable (1.2m) |

NOTE: All power cords of the above support units are non shielded (1.8m).

3.6 CONFIGURATION OF SYSTEM UNDER TEST

For conducted emission test (Adapter Mode):

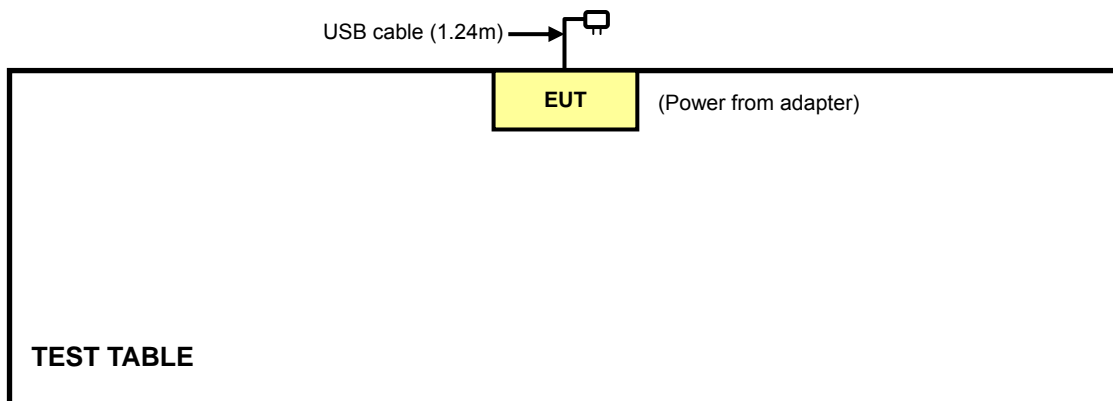

For other test items:

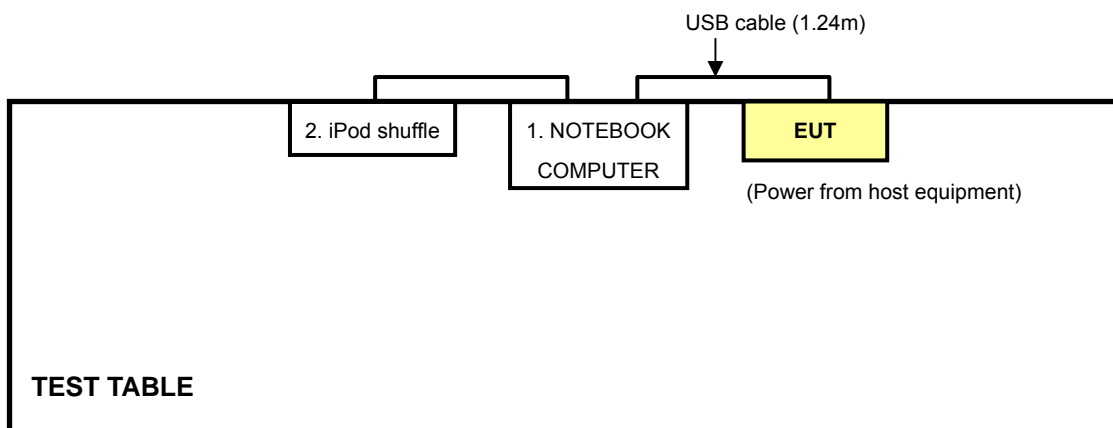

4 TEST PROCEDURES AND RESULTS

4.1 CONDUCTED EMISSION MEASUREMENT

4.1.1 LIMITS OF CONDUCTED EMISSION MEASUREMENT

| FREQUENCY OF EMISSION (MHz) | CONDUCTED LIMIT (dB μ V) | |
|-----------------------------|------------------------------|----------|
| | Quasi-peak | Average |
| 0.15-0.5 | 66 to 56 | 56 to 46 |
| 0.5-5 | 56 | 46 |
| 5-30 | 60 | 50 |

- NOTE:**
1. The lower limit shall apply at the transition frequencies.
 2. The limit decreases in line with the logarithm of the frequency in the range of 0.15 to 0.50 MHz.

4.1.2 TEST INSTRUMENTS

| DESCRIPTION & MANUFACTURER | MODEL NO. | SERIAL NO. | CALIBRATED DATE | CALIBRATED UNTIL |
|--|-----------------------------|------------|-----------------|------------------|
| Test Receiver ROHDE & SCHWARZ | ESCS 30 | 100287 | Feb. 29, 2012 | Feb. 28, 2013 |
| Line-Impedance Stabilization Network (for EUT) SCHWARZBECK | NSLK 8127 | 8127-523 | Sep. 19, 2012 | Sep. 20, 2013 |
| Line-Impedance Stabilization Network (for Peripheral) ROHDE & SCHWARZ | ESH3-Z5 | 848773/004 | Oct. 29, 2012 | Oct. 28, 2013 |
| RF Cable (JYEBAO) | 5DFB | COACAB-002 | Aug. 05, 2012 | Aug. 04, 2013 |
| 50 ohms Terminator | 50 | 3 | Oct. 23, 2012 | Oct. 22, 2013 |
| Software ADT | BV ADT_Cond_V7.3.7 .3 | NA | NA | NA |

Note:

1. The calibration interval of the above test instruments is 12 months and the calibrations are traceable to NML/ROC and NIST/USA.
2. The test was performed in Shielded Room No. A.
3. The VCCI Con A Registration No. is C-817.
4. Tested Date: Feb. 23, 2013

4.1.3 TEST PROCEDURES

- a. The EUT was placed 0.4 meters from the conducting wall of the shielded room with EUT being connected to the power mains through a line impedance stabilization network (LISN). Other support units were connected to the power mains through another LISN.
- b. The two LISNs provide 50 ohm/ 50uH of coupling impedance for the measuring instrument.
- c. Both lines of the power mains connected to the EUT were checked for maximum conducted interference.
- d. The frequency range from 150kHz to 30MHz was searched. Emission levels under (Limit – 20dB) were not recorded.

NOTE: The resolution bandwidth of test receiver is 9kHz for Quasi-peak detection (QP) & Average detection (AV).

4.1.4 DEVIATION FROM TEST STANDARD

No deviation

4.1.5 TEST SETUP

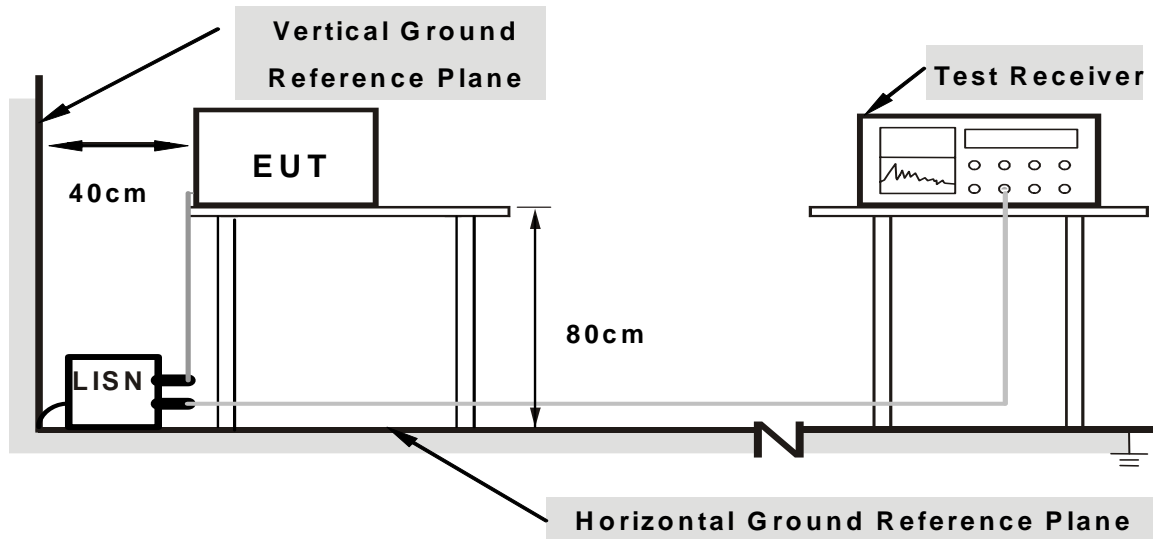

Note: 1. Support units were connected to second LISN.

For the actual test configuration, please refer to the related item – Photographs of the Test Configuration.

4.1.6 EUT OPERATING CONDITIONS

1. Turn on the power of all equipment.
2. Run test program “BlueTest3” to enable EUT under transmission/receiving condition continuously at specific channel frequency.

4.1.7 TEST RESULTS(MODE 1)

| PHASE | Line (L) | DETECTOR FUNCTION | Quasi-Peak (QP) / Average (AV) |
|-------|----------|-------------------|--------------------------------|
|-------|----------|-------------------|--------------------------------|

| No | Freq. | Corr. | Reading Value | | Emission Level | | Limit | | Margin | |
|----|---------|--------|---------------|-------|----------------|-------|-----------|-------|--------|--------|
| | [MHz] | Factor | [dB (uV)] | | [dB (uV)] | | [dB (uV)] | | (dB) | |
| | | (dB) | Q.P. | AV. | Q.P. | AV. | Q.P. | AV. | Q.P. | AV. |
| 1 | 0.15000 | 0.11 | 40.88 | 26.20 | 40.99 | 26.31 | 66.00 | 56.00 | -25.01 | -29.69 |
| 2 | 0.18516 | 0.12 | 40.80 | 23.16 | 40.92 | 23.28 | 64.25 | 54.25 | -23.33 | -30.97 |
| 3 | 0.93906 | 0.22 | 28.86 | 16.54 | 29.08 | 16.76 | 56.00 | 46.00 | -26.92 | -29.24 |
| 4 | 2.12109 | 0.28 | 33.20 | 24.74 | 33.48 | 25.02 | 56.00 | 46.00 | -22.52 | -20.98 |
| 5 | 2.48438 | 0.30 | 33.42 | 26.84 | 33.72 | 27.14 | 56.00 | 46.00 | -22.28 | -18.86 |
| 6 | 3.25391 | 0.33 | 36.92 | 29.70 | 37.25 | 30.03 | 56.00 | 46.00 | -18.75 | -15.97 |

REMARKS:

1. Q.P. and AV. are abbreviations of quasi-peak and average individually.
2. The emission levels of other frequencies were very low against the limit.
3. Margin value = Emission level - Limit value
4. Correction factor = Insertion loss + Cable loss
5. Emission Level = Correction Factor + Reading Value.

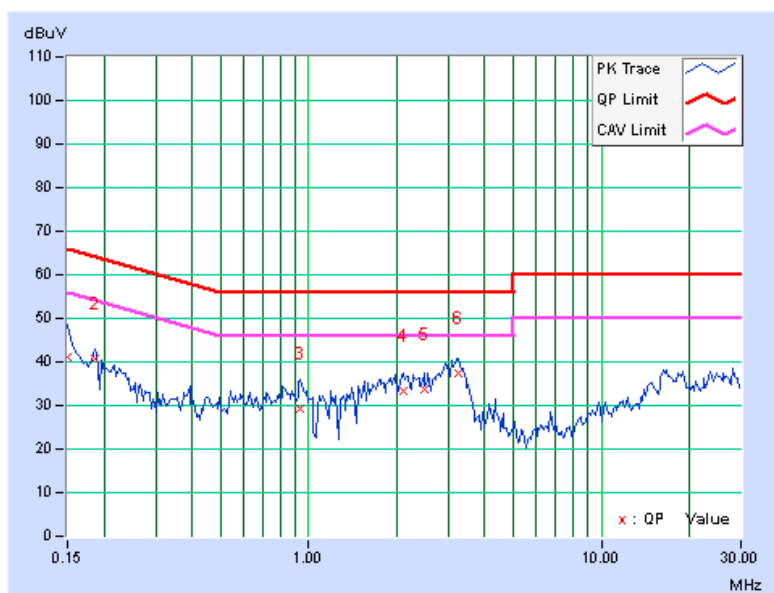



A D T

| | | | |
|--------------|-------------|--------------------------|--------------------------------|
| PHASE | Neutral (N) | DETECTOR FUNCTION | Quasi-Peak (QP) / Average (AV) |
|--------------|-------------|--------------------------|--------------------------------|

| No | Freq. | Corr. | Reading Value | | Emission Level | | Limit | | Margin | |
|----------|----------------|-------------|---------------|--------------|----------------|--------------|--------------|--------------|---------------|---------------|
| | [MHz] | Factor | [dB (uV)] | | [dB (uV)] | | [dB (uV)] | | (dB) | |
| | | (dB) | Q.P. | AV. | Q.P. | AV. | Q.P. | AV. | Q.P. | AV. |
| 1 | 0.21641 | 0.13 | 34.90 | 21.16 | 35.03 | 21.29 | 62.96 | 52.96 | -27.93 | -31.67 |
| 2 | 0.25938 | 0.14 | 30.32 | 19.02 | 30.46 | 19.16 | 61.45 | 51.45 | -30.99 | -32.29 |
| 3 | 0.35703 | 0.17 | 28.42 | 13.78 | 28.59 | 13.95 | 58.80 | 48.80 | -30.20 | -34.84 |
| 4 | 2.16016 | 0.26 | 33.06 | 26.04 | 33.32 | 26.30 | 56.00 | 46.00 | -22.68 | -19.70 |
| 5 | 2.53906 | 0.28 | 34.88 | 26.62 | 35.16 | 26.90 | 56.00 | 46.00 | -20.84 | -19.10 |
| 6 | 3.10547 | 0.31 | 36.56 | 29.78 | 36.87 | 30.09 | 56.00 | 46.00 | -19.13 | -15.91 |

REMARKS:

1. Q.P. and AV. are abbreviations of quasi-peak and average individually.
2. The emission levels of other frequencies were very low against the limit.
3. Margin value = Emission level - Limit value
4. Correction factor = Insertion loss + Cable loss
5. Emission Level = Correction Factor + Reading Value.

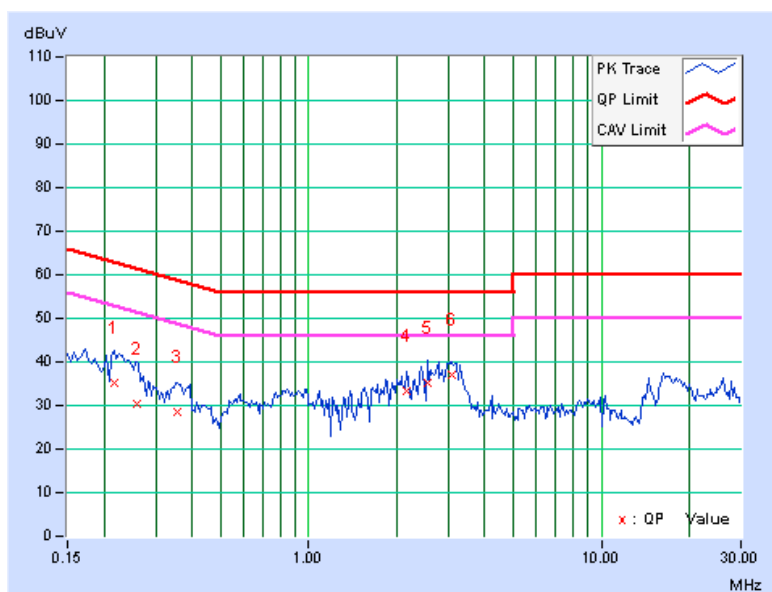



A D T

4.1.8 TEST RESULTS(MODE 2)

| PHASE | Line (L) | DETECTOR FUNCTION | Quasi-Peak (QP) / Average (AV) |
|-------|----------|-------------------|--------------------------------|
|-------|----------|-------------------|--------------------------------|

| No | Freq. [MHz] | Corr. Factor (dB) | Reading Value [dB (uV)] | | Emission Level [dB (uV)] | | Limit [dB (uV)] | | Margin (dB) | |
|----|-------------|-------------------|-------------------------|-------|--------------------------|-------|-----------------|-------|-------------|--------|
| | | | Q.P. | AV. | Q.P. | AV. | Q.P. | AV. | Q.P. | AV. |
| 1 | 0.16953 | 0.11 | 32.76 | 13.58 | 32.87 | 13.69 | 64.98 | 54.98 | -32.11 | -41.29 |
| 2 | 0.59531 | 0.20 | 29.66 | 20.46 | 29.86 | 20.66 | 56.00 | 46.00 | -26.14 | -25.34 |
| 3 | 1.21094 | 0.24 | 24.66 | 13.66 | 24.90 | 13.90 | 56.00 | 46.00 | -31.10 | -32.10 |
| 4 | 1.64453 | 0.26 | 23.90 | 13.30 | 24.16 | 13.56 | 56.00 | 46.00 | -31.84 | -32.44 |
| 5 | 2.01953 | 0.28 | 22.12 | 11.74 | 22.40 | 12.02 | 56.00 | 46.00 | -33.60 | -33.98 |
| 6 | 8.61719 | 0.65 | 22.32 | 11.24 | 22.97 | 11.89 | 60.00 | 50.00 | -37.03 | -38.11 |

REMARKS:

1. Q.P. and AV. are abbreviations of quasi-peak and average individually.
2. The emission levels of other frequencies were very low against the limit.
3. Margin value = Emission level - Limit value
4. Correction factor = Insertion loss + Cable loss
5. Emission Level = Correction Factor + Reading Value.

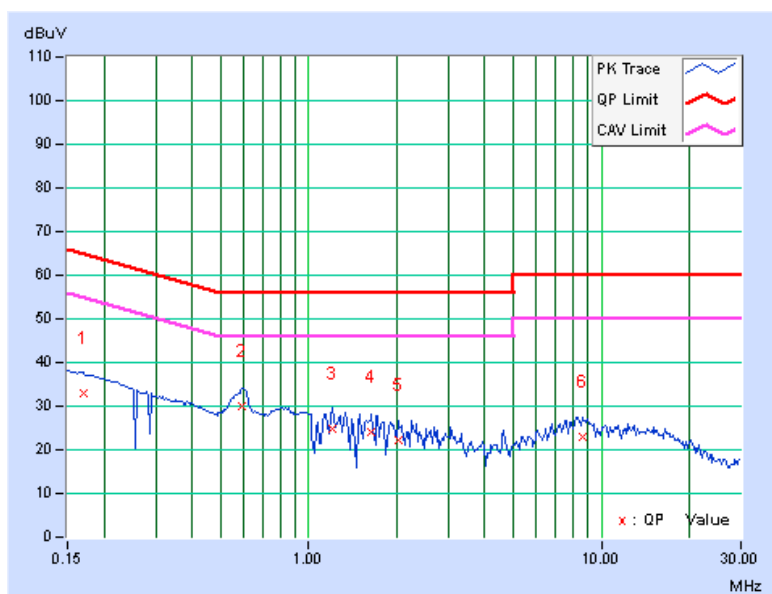



A D T

| | | | |
|--------------|-------------|--------------------------|--------------------------------|
| PHASE | Neutral (N) | DETECTOR FUNCTION | Quasi-Peak (QP) / Average (AV) |
|--------------|-------------|--------------------------|--------------------------------|

| No | Freq. | Corr. | Reading Value | | Emission Level | | Limit | | Margin | |
|----|---------|--------|---------------|-------|----------------|-------|-----------|-------|--------|--------|
| | [MHz] | Factor | [dB (uV)] | | [dB (uV)] | | [dB (uV)] | | (dB) | |
| | | (dB) | Q.P. | AV. | Q.P. | AV. | Q.P. | AV. | Q.P. | AV. |
| 1 | 0.18906 | 0.11 | 31.28 | 11.86 | 31.39 | 11.97 | 64.08 | 54.08 | -32.68 | -42.10 |
| 2 | 0.31406 | 0.16 | 27.22 | 7.22 | 27.38 | 7.38 | 59.86 | 49.86 | -32.48 | -42.48 |
| 3 | 0.57188 | 0.21 | 30.20 | 16.18 | 30.41 | 16.39 | 56.00 | 46.00 | -25.59 | -29.61 |
| 4 | 1.10156 | 0.25 | 23.06 | 9.62 | 23.31 | 9.87 | 56.00 | 46.00 | -32.69 | -36.13 |
| 5 | 1.30469 | 0.25 | 23.64 | 10.38 | 23.89 | 10.63 | 56.00 | 46.00 | -32.11 | -35.37 |
| 6 | 1.71875 | 0.25 | 22.70 | 11.06 | 22.95 | 11.31 | 56.00 | 46.00 | -33.05 | -34.69 |

REMARKS:

1. Q.P. and AV. are abbreviations of quasi-peak and average individually.
2. The emission levels of other frequencies were very low against the limit.
3. Margin value = Emission level - Limit value
4. Correction factor = Insertion loss + Cable loss
5. Emission Level = Correction Factor + Reading Value.

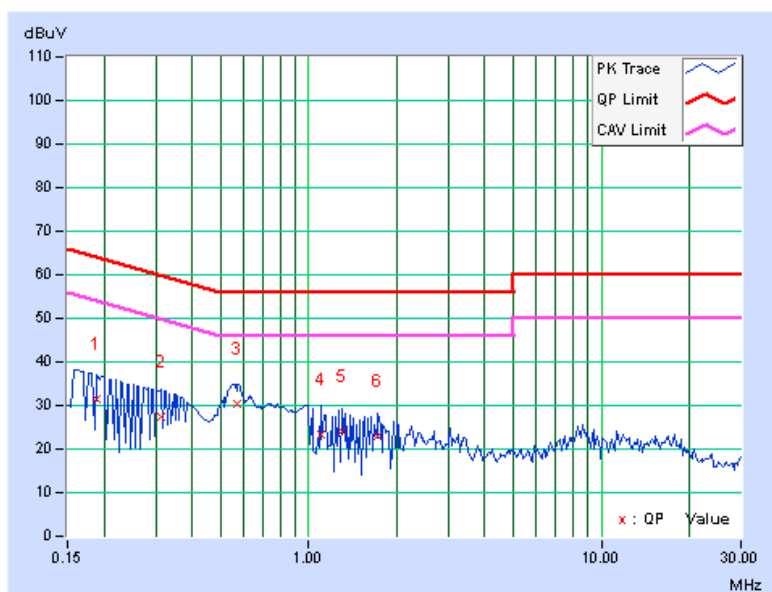

4.2 RADIATED EMISSION AND BANDEGE MEASUREMENT

4.2.1 LIMITS OF RADIATED EMISSION AND BANDEGE MEASUREMENT

Radiated emissions which fall in the restricted bands must comply with the radiated emission limits specified as below table. Other emissions shall be at least 20dB below the highest level of the desired power:

| FREQUENCIES (MHz) | FIELD STRENGTH (microvolts/meter) | MEASUREMENT DISTANCE (meters) |
|-------------------|-----------------------------------|-------------------------------|
| 0.009 ~ 0.490 | 2400/F(kHz) | 300 |
| 0.490 ~ 1.705 | 24000/F(kHz) | 30 |
| 1.705 ~ 30.0 | 30 | 30 |
| 30 ~ 88 | 100 | 3 |
| 88 ~ 216 | 150 | 3 |
| 216 ~ 960 | 200 | 3 |
| Above 960 | 500 | 3 |

NOTE:

1. The lower limit shall apply at the transition frequencies.
2. Emission level (dBuV/m) = 20 log Emission level (uV/m).
3. For frequencies above 1000MHz, the field strength limits are based on average detector, however, the peak field strength of any emission shall not exceed the maximum permitted average limits, specified above by more than 20dB.

4.2.2 TEST INSTRUMENTS

For below 1GHz test:

| DESCRIPTION & MANUFACTURER | MODEL NO. | SERIAL NO. | CALIBRATED DATE | CALIBRATED UNTIL |
|---|--------------------------|-------------------------------------|-----------------|------------------|
| Spectrum Analyzer Agilent | E4446A | MY48250254 | July 09, 2012 | July 08, 2013 |
| Pre-Selector Agilent | N9039A | MY46520311 | July 09, 2012 | July 08, 2013 |
| Signal Generator Agilent | N5181A | MY49060517 | July 09, 2012 | July 08, 2013 |
| Pre-Amplifier Mini-Circuits | ZFL-1000VH2 B | AMP-ZFL-03 | Nov. 14, 2012 | Nov. 13, 2013 |
| Pre-Amplifier Agilent | 8449B | 3008A02578 | June 26, 2012 | June 25, 2013 |
| Pre-Amplifier SPACEK LABS | SLKKa-48-6 | 9K16 | Nov. 14, 2012 | Nov. 13, 2013 |
| Trilog Broadband Antenna SCHWARZBECK | VULB 9168 | 9168-360 | Apr. 09, 2012 | Apr. 08, 2013 |
| Horn_Antenna AISI | AIH.8018 | 0000320091110 | Nov. 19, 2012 | Nov. 18, 2013 |
| Horn_Antenna SCHWARZBECK | BBHA 9170 | 9170-424 | Oct. 12, 2012 | Oct. 11, 2013 |
| RF Cable | NA | RF104-201 RF104-203 RF104-204 | Dec. 25, 2012 | Dec. 24, 2013 |
| RF Cable | NA | CHGCAB_001 | Oct. 06, 2012 | Oct. 05, 2013 |
| Software | ADT_Radiated _V8.7.05 | NA | NA | NA |
| Antenna Tower & Turn Table CT | NA | NA | NA | NA |

Note:

1. The calibration interval of the above test instruments is 12 months and the calibrations are traceable to NML/ROC and NIST/USA.
2. The horn antenna, preamplifier (model: 8449B) are used only for the measurement of emission frequency above 1GHz if tested.
3. The test was performed in 966 Chamber No. G.
4. The FCC Site Registration No. is 966073.
5. The VCCI Site Registration No. is G-137.
6. The CANADA Site Registration No. is IC 7450H-2.
7. Tested Date: Feb. 20, 2013



A D T

For above 1GHz test:

| DESCRIPTION & MANUFACTURER | MODEL NO. | SERIAL NO. | CALIBRATED DATE | CALIBRATED UNTIL |
|---|--------------------------|-------------------------------------|-----------------|------------------|
| Spectrum Analyzer Agilent | E4446A | MY48250253 | Sep. 03, 2012 | Sep. 02, 2013 |
| Pre-Selector Agilent | N9039A | MY46520310 | Sep. 03, 2012 | Sep. 02, 2013 |
| Signal Generator Agilent | N5181A | MY49060347 | July 24, 2012 | July 23, 2013 |
| Pre-Amplifier Mini-Circuits | ZFL-1000VH2 B | AMP-ZFL-04 | Nov. 14, 2012 | Nov. 13, 2013 |
| Pre-Amplifier Agilent | 8449B | 3008A02465 | Feb. 27, 2012 | Feb. 26, 2013 |
| SPACEK LABS | SLKKa-48-6 | 9K16 | Nov. 14, 2012 | Nov. 13, 2013 |
| Trilog Broadband Antenna SCHWARZBECK | VULB 9168 | 9168-361 | Apr. 06, 2012 | Apr. 05, 2013 |
| Horn_Antenna AISI | AIH.8018 | 0000220091110 | Nov. 22, 2012 | Nov. 21, 2013 |
| Horn_Antenna SCHWARZBECK | BBHA 9170 | 9170-424 | Oct. 12, 2012 | Oct. 11, 2013 |
| RF Cable | NA | RF104-205 RF104-207 RF104-202 | Dec. 26, 2012 | Dec. 25, 2013 |
| RF Cable | NA | CHHCAB_001 | Oct. 07, 2012 | Oct. 06, 2013 |
| Software | ADT_Radiated _V8.7.05 | NA | NA | NA |
| Antenna Tower & Turn Table CT | NA | NA | NA | NA |

Note:

1. The calibration interval of the above test instruments is 12 months and the calibrations are traceable to NML/ROC and NIST/USA.
2. The horn antenna, preamplifier (model: 8449B) are used only for the measurement of emission frequency above 1GHz if tested.
- 3 The test was performed in 966 Chamber No. H.
4. The FCC Site Registration No. is 797305.
- 5 The CANADA Site Registration No. is IC 7450H-3.
- 6 Tested Date: Feb. 22, 2013

4.2.3 TEST PROCEDURES

- a. The EUT was placed on the top of a rotating table 0.8 meters above the ground at a 3 meters chamber room. The table was rotated 360 degrees to determine the position of the highest radiation.
- b. The EUT was set 3 meters away from the interference-receiving antenna, which was mounted on the top of a variable-height antenna tower.
- c. The height of antenna is varied from one meter to four meters above the ground to determine the maximum value of the field strength. Both horizontal and vertical polarizations of the antenna are set to make the measurement.
- d. For each suspected emission, the EUT was arranged to its worst case and then the antenna was tuned to heights from 1 meter to 4 meters and the rotatable table was turned from 0 degrees to 360 degrees to find the maximum reading.
- e. The test-receiver system was set to quasi-peak detect function and specified bandwidth with maximum hold mode when the test frequency is below 1 GHz.
- f. The test-receiver system was set to peak detect function and specified bandwidth with maximum hold mode when the test frequency is above 1 GHz.

NOTE:

1. The resolution bandwidth and video bandwidth of test receiver/spectrum analyzer is 120kHz for Quasi-peak detection (QP) at frequency below 1GHz.
2. The resolution bandwidth of test receiver/spectrum analyzer is 1MHz and video bandwidth is 1MHz for Peak detection at frequency above 1GHz.
3. All modes of operation were investigated and the worst-case emissions are reported.

4.2.4 DEVIATION FROM TEST STANDARD

No deviation

4.2.5 TEST SETUP

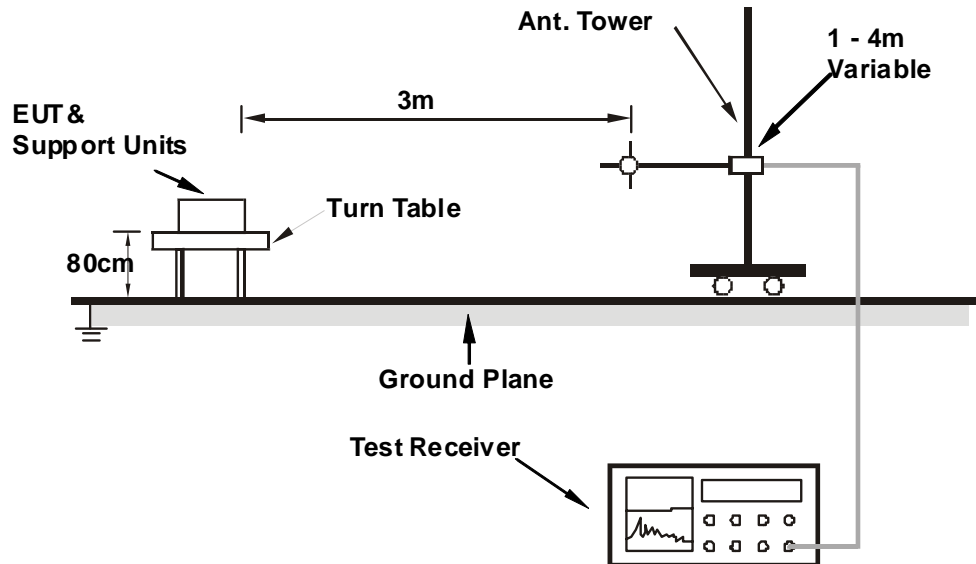

For the actual test configuration, please refer to the related item – Photographs of the Test Configuration.

4.2.6 EUT OPERATING CONDITIONS

Same as 4.1.6

4.2.7 TEST RESULTS

BELOW 1GHz WORST-CASE DATA

BT_8DPSK

| | | | |
|------------------------|--------------|------------------------------|-----------------|
| CHANNEL | TX Channel 0 | DETECTOR FUNCTION | Quasi-Peak (QP) |
| FREQUENCY RANGE | 30MHz ~ 1GHz | | |

| ANTENNA POLARITY & TEST DISTANCE: HORIZONTAL AT 3 M | | | | | | | | |
|---|----------------|-------------------------------|-------------------|----------------|--------------------------|----------------------------|------------------------|--------------------------------|
| NO. | FREQ. (MHz) | EMISSION LEVEL (dBuV/m) | LIMIT (dBuV/m) | MARGIN (dB) | ANTENNA HEIGHT (m) | TABLE ANGLE (Degree) | RAW VALUE (dBuV) | CORRECTION FACTOR (dB/m) |
| 1 | 64.58 | 29.7 QP | 40.0 | -10.3 | 2.00 H | 0 | 16.54 | 13.18 |
| 2 | 139.54 | 30.2 QP | 43.5 | -13.3 | 2.00 H | 73 | 16.31 | 13.90 |
| 3 | 203.96 | 34.0 QP | 43.5 | -9.5 | 1.50 H | 360 | 22.65 | 11.33 |
| 4 | 212.02 | 37.6 QP | 43.5 | -5.9 | 1.50 H | 30 | 25.91 | 11.69 |
| 5 | 232.38 | 33.1 QP | 46.0 | -13.0 | 1.50 H | 360 | 20.47 | 12.58 |
| 6 | 960.09 | 33.5 QP | 54.0 | -20.5 | 1.50 H | 313 | 5.49 | 28.05 |
| ANTENNA POLARITY & TEST DISTANCE: VERTICAL AT 3 M | | | | | | | | |
| NO. | FREQ. (MHz) | EMISSION LEVEL (dBuV/m) | LIMIT (dBuV/m) | MARGIN (dB) | ANTENNA HEIGHT (m) | TABLE ANGLE (Degree) | RAW VALUE (dBuV) | CORRECTION FACTOR (dB/m) |
| 1 | 65.05 | 25.4 QP | 40.0 | -14.6 | 1.00 V | 272 | 12.29 | 13.13 |
| 2 | 145.70 | 25.4 QP | 43.5 | -18.2 | 1.00 V | 117 | 10.81 | 14.54 |
| 3 | 204.08 | 26.6 QP | 43.5 | -16.9 | 1.00 V | 315 | 15.23 | 11.34 |
| 4 | 403.98 | 26.6 QP | 46.0 | -19.4 | 1.00 V | 360 | 8.65 | 17.96 |
| 5 | 441.05 | 29.2 QP | 46.0 | -16.8 | 1.00 V | 360 | 10.29 | 18.91 |
| 6 | 600.09 | 28.3 QP | 46.0 | -17.7 | 1.00 V | 360 | 5.63 | 22.66 |

REMARKS:

1. Emission level (dBuV/m) = Raw Value (dBuV) + Correction Factor (dB/m).
2. Correction Factor (dB/m) = Antenna Factor (dB/m) + Cable Factor (dB).
3. The other emission levels were very low against the limit.
4. Margin value = Emission level – Limit value.

ABOVE 1GHz DATA

BT_GFSK

| | | | |
|------------------------|--------------|------------------------------|-----------|
| CHANNEL | TX Channel 0 | DETECTOR FUNCTION | Peak (PK) |
| FREQUENCY RANGE | 1GHz ~ 25GHz | | |

| ANTENNA POLARITY & TEST DISTANCE: HORIZONTAL AT 3 M | | | | | | | | |
|---|----------------|-------------------------------|-------------------|----------------|--------------------------|----------------------------|------------------------|--------------------------------|
| NO. | FREQ. (MHz) | EMISSION LEVEL (dBuV/m) | LIMIT (dBuV/m) | MARGIN (dB) | ANTENNA HEIGHT (m) | TABLE ANGLE (Degree) | RAW VALUE (dBuV) | CORRECTION FACTOR (dB/m) |
| 1 | 2390.00 | 55.7 PK | 74.0 | -18.3 | 1.44 H | 217 | 22.92 | 32.78 |
| 2 | 2390.00 | 25.6 AV | 54.0 | -28.4 | 1.44 H | 217 | -7.18 | 32.78 |
| 3 | *2402.00 | 102.4 PK | | | 1.44 H | 217 | 69.58 | 32.82 |
| 4 | *2402.00 | 72.3 AV | | | 1.44 H | 217 | 39.48 | 32.82 |
| 5 | 4804.00 | 53.9 PK | 74.0 | -20.1 | 1.11 H | 319 | 11.65 | 42.25 |
| 6 | 4804.00 | 24.1 AV | 54.0 | -29.9 | 1.11 H | 319 | -18.15 | 42.25 |
| ANTENNA POLARITY & TEST DISTANCE: VERTICAL AT 3 M | | | | | | | | |
| NO. | FREQ. (MHz) | EMISSION LEVEL (dBuV/m) | LIMIT (dBuV/m) | MARGIN (dB) | ANTENNA HEIGHT (m) | TABLE ANGLE (Degree) | RAW VALUE (dBuV) | CORRECTION FACTOR (dB/m) |
| 1 | 2390.00 | 55.4 PK | 74.0 | -18.6 | 1.00 V | 95 | 22.62 | 32.78 |
| 2 | 2390.00 | 25.3 AV | 54.0 | -28.7 | 1.00 V | 95 | -7.48 | 32.78 |
| 3 | *2402.00 | 96.5 PK | | | 1.00 V | 95 | 63.68 | 32.82 |
| 4 | *2402.00 | 66.4 AV | | | 1.00 V | 95 | 33.58 | 32.82 |
| 5 | 4804.00 | 58.8 PK | 74.0 | -15.2 | 1.00 V | 192 | 16.55 | 42.25 |
| 6 | 4804.00 | 28.5 AV | 54.0 | -25.5 | 1.00 V | 192 | -13.75 | 42.25 |

REMARKS:

1. Emission level (dBuV/m) = Raw Value (dBuV) + Correction Factor (dB/m).
2. Correction Factor (dB/m) = Antenna Factor (dB/m) + Cable Factor (dB).
3. The other emission levels were very low against the limit.
4. Margin value = Emission level – Limit value.
5. " * ": Fundamental frequency.
6. The DH5 packet was the worse case duty cycle for a transmit dwell time on a channel, based upon bluetooth theory the transmitter is on $0.625 * 5$ per 296.25 ms per channel. Therefore, the duty cycle correlation factor be equal to: $20\log(3.125 / 100) = -30.1$ dB.
7. Average value = peak reading + $20\log(\text{duty cycle})$.



A D T

| | | | |
|------------------------|---------------|------------------------------|-----------|
| CHANNEL | TX Channel 39 | DETECTOR FUNCTION | Peak (PK) |
| FREQUENCY RANGE | 1GHz ~ 25GHz | | |

| ANTENNA POLARITY & TEST DISTANCE: HORIZONTAL AT 3 M | | | | | | | | |
|---|----------------|-------------------------------|-------------------|----------------|--------------------------|----------------------------|------------------------|--------------------------------|
| NO. | FREQ. (MHz) | EMISSION LEVEL (dBuV/m) | LIMIT (dBuV/m) | MARGIN (dB) | ANTENNA HEIGHT (m) | TABLE ANGLE (Degree) | RAW VALUE (dBuV) | CORRECTION FACTOR (dB/m) |
| 1 | *2441.00 | 102.5 PK | | | 1.42 H | 221 | 69.58 | 32.92 |
| 2 | *2441.00 | 72.4 AV | | | 1.42 H | 221 | 39.48 | 32.92 |
| 3 | 4882.00 | 54.0 PK | 74.0 | -20.0 | 1.18 H | 303 | 11.68 | 42.32 |
| 4 | 4882.00 | 23.9 AV | 54.0 | -30.1 | 1.18 H | 303 | -18.42 | 42.32 |
| 5 | 7323.00 | 53.6 PK | 74.0 | -20.4 | 1.00 H | 185 | 6.61 | 46.99 |
| 6 | 7323.00 | 23.5 AV | 54.0 | -30.5 | 1.00 H | 185 | -23.49 | 46.99 |
| ANTENNA POLARITY & TEST DISTANCE: VERTICAL AT 3 M | | | | | | | | |
| NO. | FREQ. (MHz) | EMISSION LEVEL (dBuV/m) | LIMIT (dBuV/m) | MARGIN (dB) | ANTENNA HEIGHT (m) | TABLE ANGLE (Degree) | RAW VALUE (dBuV) | CORRECTION FACTOR (dB/m) |
| 1 | *2441.00 | 96.4 PK | | | 1.00 V | 95 | 63.48 | 32.92 |
| 2 | *2441.00 | 66.3 AV | | | 1.00 V | 95 | 33.38 | 32.92 |
| 3 | 4882.00 | 58.7 PK | 74.0 | -15.3 | 1.02 V | 181 | 16.38 | 42.32 |
| 4 | 4882.00 | 28.6 AV | 54.0 | -25.4 | 1.02 V | 181 | -13.72 | 42.32 |
| 5 | 7323.00 | 54.9 PK | 74.0 | -19.1 | 1.00 V | 23 | 7.91 | 46.99 |
| 6 | 7323.00 | 24.8 AV | 54.0 | -29.2 | 1.00 V | 23 | -22.19 | 46.99 |

REMARKS:

1. Emission level (dBuV/m) = Raw Value (dBuV) + Correction Factor (dB/m).
2. Correction Factor (dB/m) = Antenna Factor (dB/m) + Cable Factor (dB).
3. The other emission levels were very low against the limit.
4. Margin value = Emission level – Limit value.
5. " * ": Fundamental frequency.
6. The DH5 packet was the worse case duty cycle for a transmit dwell time on a channel, based upon bluetooth theory the transmitter is on $0.625 * 5$ per 296.25 ms per channel. Therefore, the duty cycle correlation factor be equal to: $20\log(3.125 / 100) = -30.1$ dB.
7. Average value = peak reading + $20\log(\text{duty cycle})$.



A D T

| | | | |
|------------------------|---------------|------------------------------|-----------|
| CHANNEL | TX Channel 78 | DETECTOR FUNCTION | Peak (PK) |
| FREQUENCY RANGE | 1GHz ~ 25GHz | | |

ANTENNA POLARITY & TEST DISTANCE: HORIZONTAL AT 3 M

| NO. | FREQ. (MHz) | EMISSION LEVEL (dBuV/m) | LIMIT (dBuV/m) | MARGIN (dB) | ANTENNA HEIGHT (m) | TABLE ANGLE (Degree) | RAW VALUE (dBuV) | CORRECTION FACTOR (dB/m) |
|-----|----------------|-------------------------------|-------------------|----------------|--------------------------|----------------------------|------------------------|--------------------------------|
| 1 | *2480.00 | 102.2 PK | | | 1.39 H | 221 | 69.18 | 33.02 |
| 2 | *2480.00 | 72.1 AV | | | 1.39 H | 221 | 39.08 | 33.02 |
| 3 | 2483.50 | 65.1 PK | 74.0 | -8.9 | 1.39 H | 221 | 32.07 | 33.03 |
| 4 | 2483.50 | 35.0 AV | 54.0 | -19.0 | 1.39 H | 221 | 1.97 | 33.03 |
| 5 | 4960.00 | 54.1 PK | 74.0 | -19.9 | 1.20 H | 307 | 11.80 | 42.30 |
| 6 | 4960.00 | 24.0 AV | 54.0 | -30.0 | 1.20 H | 307 | -18.30 | 42.30 |
| 7 | 7440.00 | 54.5 PK | 74.0 | -19.5 | 1.03 H | 180 | 7.21 | 47.29 |
| 8 | 7440.00 | 24.4 AV | 54.0 | -29.6 | 1.03 H | 180 | -22.89 | 47.29 |

ANTENNA POLARITY & TEST DISTANCE: VERTICAL AT 3 M

| NO. | FREQ. (MHz) | EMISSION LEVEL (dBuV/m) | LIMIT (dBuV/m) | MARGIN (dB) | ANTENNA HEIGHT (m) | TABLE ANGLE (Degree) | RAW VALUE (dBuV) | CORRECTION FACTOR (dB/m) |
|-----|----------------|-------------------------------|-------------------|----------------|--------------------------|----------------------------|------------------------|--------------------------------|
| 1 | *2480.00 | 96.1 PK | | | 1.21 V | 96 | 63.08 | 33.02 |
| 2 | *2480.00 | 66.0 AV | | | 1.21 V | 96 | 32.98 | 33.02 |
| 3 | 2483.50 | 63.0 PK | 74.0 | -11.0 | 1.21 V | 95 | 29.97 | 33.03 |
| 4 | 2483.50 | 32.9 AV | 54.0 | -21.1 | 1.21 V | 95 | -0.13 | 33.03 |
| 5 | 4960.00 | 59.5 PK | 74.0 | -14.5 | 1.05 V | 197 | 17.20 | 42.30 |
| 6 | 4960.00 | 29.4 AV | 54.0 | -24.6 | 1.05 V | 197 | -12.90 | 42.30 |
| 7 | 7440.00 | 54.3 PK | 74.0 | -19.7 | 1.00 V | 10 | 7.01 | 47.29 |
| 8 | 7440.00 | 24.2 AV | 54.0 | -29.8 | 1.00 V | 10 | -23.09 | 47.29 |

REMARKS:

1. Emission level (dBuV/m) = Raw Value (dBuV) + Correction Factor (dB/m).
2. Correction Factor (dB/m) = Antenna Factor (dB/m) + Cable Factor (dB).
3. The other emission levels were very low against the limit.
4. Margin value = Emission level – Limit value.
5. " * ": Fundamental frequency.
6. The DH5 packet was the worse case duty cycle for a transmit dwell time on a channel, based upon bluetooth theory the transmitter is on 0.625 * 5 per 296.25 ms per channel. Therefore, the duty cycle correlation factor be equal to: $20\log(3.125 / 100) = -30.1 \text{ dB}$.
7. Average value = peak reading + $20\log(\text{duty cycle})$.

BT_8DPSK

| | | | |
|-----------------|--------------|-------------------|-----------|
| CHANNEL | TX Channel 0 | DETECTOR FUNCTION | Peak (PK) |
| FREQUENCY RANGE | 1GHz ~ 25GHz | | |

ANTENNA POLARITY & TEST DISTANCE: HORIZONTAL AT 3 M

| NO. | FREQ. (MHz) | EMISSION LEVEL (dBuV/m) | LIMIT (dBuV/m) | MARGIN (dB) | ANTENNA HEIGHT (m) | TABLE ANGLE (Degree) | RAW VALUE (dBuV) | CORRECTION FACTOR (dB/m) |
|-----|-------------|-------------------------|----------------|-------------|--------------------|----------------------|------------------|--------------------------|
| 1 | 2390.00 | 57.2 PK | 74.0 | -16.8 | 1.42 H | 215 | 24.42 | 32.78 |
| 2 | 2390.00 | 27.1 AV | 54.0 | -26.9 | 1.42 H | 215 | -5.68 | 32.78 |
| 3 | *2402.00 | 103.9 PK | | | 1.42 H | 215 | 71.08 | 32.82 |
| 4 | *2402.00 | 73.8 AV | | | 1.42 H | 215 | 40.98 | 32.82 |
| 5 | 4804.00 | 53.2 PK | 74.0 | -20.8 | 1.02 H | 251 | 10.95 | 42.25 |
| 6 | 4804.00 | 23.1 AV | 54.0 | -30.9 | 1.02 H | 251 | -19.15 | 42.25 |

ANTENNA POLARITY & TEST DISTANCE: VERTICAL AT 3 M

| NO. | FREQ. (MHz) | EMISSION LEVEL (dBuV/m) | LIMIT (dBuV/m) | MARGIN (dB) | ANTENNA HEIGHT (m) | TABLE ANGLE (Degree) | RAW VALUE (dBuV) | CORRECTION FACTOR (dB/m) |
|-----|-------------|-------------------------|----------------|-------------|--------------------|----------------------|------------------|--------------------------|
| 1 | 2390.00 | 56.8 PK | 74.0 | -17.2 | 1.23 V | 97 | 24.02 | 32.78 |
| 2 | 2390.00 | 26.7 AV | 54.0 | -27.3 | 1.23 V | 97 | -6.08 | 32.78 |
| 3 | *2402.00 | 97.6 PK | | | 1.23 V | 97 | 64.78 | 32.82 |
| 4 | *2402.00 | 67.5 AV | | | 1.23 V | 97 | 34.68 | 32.82 |
| 5 | 4804.00 | 58.2 PK | 74.0 | -15.8 | 1.03 V | 173 | 15.95 | 42.25 |
| 6 | 4804.00 | 28.1 AV | 54.0 | -25.9 | 1.03 V | 173 | -14.15 | 42.25 |

REMARKS:

1. Emission level (dBuV/m) = Raw Value (dBuV) + Correction Factor (dB/m).
2. Correction Factor (dB/m) = Antenna Factor (dB/m) + Cable Factor (dB).
3. The other emission levels were very low against the limit.
4. Margin value = Emission level – Limit value.
5. " * ": Fundamental frequency.
6. The DH5 packet was the worse case duty cycle for a transmit dwell time on a channel, based upon bluetooth theory the transmitter is on $0.625 * 5$ per 296.25 ms per channel. Therefore, the duty cycle correlation factor be equal to: $20\log(3.125 / 100) = -30.1$ dB.
7. Average value = peak reading + $20\log(\text{duty cycle})$.



A D T

| | | | |
|------------------------|---------------|--------------------------|-----------|
| CHANNEL | TX Channel 39 | DETECTOR FUNCTION | Peak (PK) |
| FREQUENCY RANGE | 1GHz ~ 25GHz | | |

ANTENNA POLARITY & TEST DISTANCE: HORIZONTAL AT 3 M

| NO. | FREQ. (MHz) | EMISSION LEVEL (dBuV/m) | LIMIT (dBuV/m) | MARGIN (dB) | ANTENNA HEIGHT (m) | TABLE ANGLE (Degree) | RAW VALUE (dBuV) | CORRECTION FACTOR (dB/m) |
|-----|-------------|-------------------------|----------------|-------------|--------------------|----------------------|------------------|--------------------------|
| 1 | *2441.00 | 103.1 PK | | | 1.42 H | 218 | 70.18 | 32.92 |
| 2 | *2441.00 | 73.0 AV | | | 1.42 H | 218 | 40.08 | 32.92 |
| 3 | 4882.00 | 52.8 PK | 74.0 | -21.2 | 1.00 H | 252 | 10.48 | 42.32 |
| 4 | 4882.00 | 22.7 AV | 54.0 | -31.3 | 1.00 H | 252 | -19.62 | 42.32 |
| 5 | 7323.00 | 54.8 PK | 74.0 | -19.2 | 1.04 H | 192 | 7.81 | 46.99 |
| 6 | 7323.00 | 24.7 AV | 54.0 | -29.3 | 1.04 H | 192 | -22.29 | 46.99 |

ANTENNA POLARITY & TEST DISTANCE: VERTICAL AT 3 M

| NO. | FREQ. (MHz) | EMISSION LEVEL (dBuV/m) | LIMIT (dBuV/m) | MARGIN (dB) | ANTENNA HEIGHT (m) | TABLE ANGLE (Degree) | RAW VALUE (dBuV) | CORRECTION FACTOR (dB/m) |
|-----|-------------|-------------------------|----------------|-------------|--------------------|----------------------|------------------|--------------------------|
| 1 | *2441.00 | 96.8 PK | | | 1.22 V | 96 | 63.88 | 32.92 |
| 2 | *2441.00 | 66.7 AV | | | 1.22 V | 96 | 33.78 | 32.92 |
| 3 | 4882.00 | 58.7 PK | 74.0 | -15.3 | 1.00 V | 172 | 16.38 | 42.32 |
| 4 | 4882.00 | 28.6 AV | 54.0 | -25.4 | 1.00 V | 172 | -13.72 | 42.32 |
| 5 | 7323.00 | 53.4 PK | 74.0 | -20.6 | 1.01 V | 17 | 6.41 | 46.99 |
| 6 | 7323.00 | 23.3 AV | 54.0 | -30.7 | 1.01 V | 17 | -23.69 | 46.99 |

REMARKS:

1. Emission level (dBuV/m) = Raw Value (dBuV) + Correction Factor (dB/m).
2. Correction Factor (dB/m) = Antenna Factor (dB/m) + Cable Factor (dB).
3. The other emission levels were very low against the limit.
4. Margin value = Emission level – Limit value.
5. " * ": Fundamental frequency.
6. The DH5 packet was the worse case duty cycle for a transmit dwell time on a channel, based upon bluetooth theory the transmitter is on 0.625 * 5 per 296.25 ms per channel. Therefore, the duty cycle correlation factor be equal to: $20\log(3.125 / 100) = -30.1$ dB.
7. Average value = peak reading + $20\log(\text{duty cycle})$.



A D T

| | | | |
|------------------------|---------------|--------------------------|-----------|
| CHANNEL | TX Channel 78 | DETECTOR FUNCTION | Peak (PK) |
| FREQUENCY RANGE | 1GHz ~ 25GHz | | |

ANTENNA POLARITY & TEST DISTANCE: HORIZONTAL AT 3 M

| NO. | FREQ. (MHz) | EMISSION LEVEL (dBuV/m) | LIMIT (dBuV/m) | MARGIN (dB) | ANTENNA HEIGHT (m) | TABLE ANGLE (Degree) | RAW VALUE (dBuV) | CORRECTION FACTOR (dB/m) |
|-----|-------------|-------------------------|----------------|-------------|--------------------|----------------------|------------------|--------------------------|
| 1 | *2480.00 | 102.7 PK | | | 1.39 H | 222 | 69.68 | 33.02 |
| 2 | *2480.00 | 72.6 AV | | | 1.39 H | 222 | 39.58 | 33.02 |
| 3 | 2483.50 | 56.9 PK | 74.0 | -17.1 | 1.39 H | 222 | 23.87 | 33.03 |
| 4 | 2483.50 | 26.8 AV | 54.0 | -27.2 | 1.39 H | 222 | -6.23 | 33.03 |
| 5 | 4960.00 | 52.8 PK | 74.0 | -21.2 | 1.04 H | 255 | 10.50 | 42.30 |
| 6 | 4960.00 | 22.7 AV | 54.0 | -31.3 | 1.04 H | 255 | -19.60 | 42.30 |
| 7 | 7440.00 | 54.8 PK | 74.0 | -19.2 | 1.00 H | 197 | 7.51 | 47.29 |
| 8 | 7440.00 | 24.7 AV | 54.0 | -29.3 | 1.00 H | 197 | -22.59 | 47.29 |

ANTENNA POLARITY & TEST DISTANCE: VERTICAL AT 3 M

| NO. | FREQ. (MHz) | EMISSION LEVEL (dBuV/m) | LIMIT (dBuV/m) | MARGIN (dB) | ANTENNA HEIGHT (m) | TABLE ANGLE (Degree) | RAW VALUE (dBuV) | CORRECTION FACTOR (dB/m) |
|-----|-------------|-------------------------|----------------|-------------|--------------------|----------------------|------------------|--------------------------|
| 1 | *2480.00 | 101.9 PK | | | 1.21 V | 97 | 68.88 | 33.02 |
| 2 | *2480.00 | 71.8 AV | | | 1.21 V | 97 | 38.78 | 33.02 |
| 3 | 2483.50 | 56.4 PK | 74.0 | -17.6 | 1.21 V | 97 | 23.37 | 33.03 |
| 4 | 2483.50 | 26.3 AV | 54.0 | -27.7 | 1.21 V | 97 | -6.73 | 33.03 |
| 5 | 4960.00 | 58.8 PK | 74.0 | -15.2 | 1.04 V | 205 | 16.50 | 42.30 |
| 6 | 4960.00 | 28.7 AV | 54.0 | -25.3 | 1.04 V | 205 | -13.60 | 42.30 |
| 7 | 7440.00 | 53.4 PK | 74.0 | -20.6 | 1.02 V | 23 | 6.11 | 47.29 |
| 8 | 7440.00 | 23.3 AV | 54.0 | -30.7 | 1.02 V | 23 | -23.99 | 47.29 |

REMARKS:

1. Emission level (dBuV/m) = Raw Value (dBuV) + Correction Factor (dB/m).
2. Correction Factor (dB/m) = Antenna Factor (dB/m) + Cable Factor (dB).
3. The other emission levels were very low against the limit.
4. Margin value = Emission level – Limit value.
5. " * ": Fundamental frequency.
6. The DH5 packet was the worse case duty cycle for a transmit dwell time on a channel, based upon bluetooth theory the transmitter is on 0.625 * 5 per 296.25 ms per channel. Therefore, the duty cycle correlation factor be equal to: $20\log(3.125 / 100) = -30.1$ dB.
7. Average value = peak reading + $20\log(\text{duty cycle})$.

4.3 NUMBER OF HOPPING FREQUENCY USED

4.3.1 LIMIT OF HOPPING FREQUENCY USED

At least 15 hopping frequencies, and should be equally spaced.

4.3.2 TEST INSTRUMENTS

| DESCRIPTION & MANUFACTURER | MODEL NO. | SERIAL NO. | CALIBRATED DATE | CALIBRATED UNTIL |
|----------------------------|-----------|------------|-----------------|------------------|
| R&S SPECTRUM ANALYZER | FSP40 | 100037 | Nov. 01, 2012 | Oct. 31, 2013 |

Note:

1. The calibration interval of the above test instruments is 12 months and the calibrations are traceable to NML/ROC and NIST/USA.
2. Tested date : Feb. 20, 2013

4.3.3 TEST PROCEDURES

- a. Check the calibration of the measuring instrument (SA) using either an internal calibrator or a known signal from an external generator.
- b. Turn on the EUT and connect its antenna terminal to measurement via a low loss cable. Then set it to any one measured frequency within its operating range and make sure the instrument is operated in its linear range.
- c. Set the SA on Max Hold Mode, and then keep the EUT in hopping mode. Record all the signals from each channel until each one has been recorded.
- d. Set the SA on View mode and then plot the result on SA screen.
- e. Repeat above procedures until all frequencies measured were complete.

4.3.4 DEVIATION FROM TEST STANDARD

No deviation

4.3.5 TEST SETUP

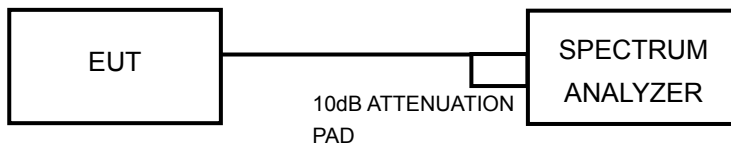

4.3.6 TEST RESULTS

There are 79 hopping frequencies in the hopping mode. Please refer to the test result. On the plots, it shows that the hopping frequencies are equally spaced.

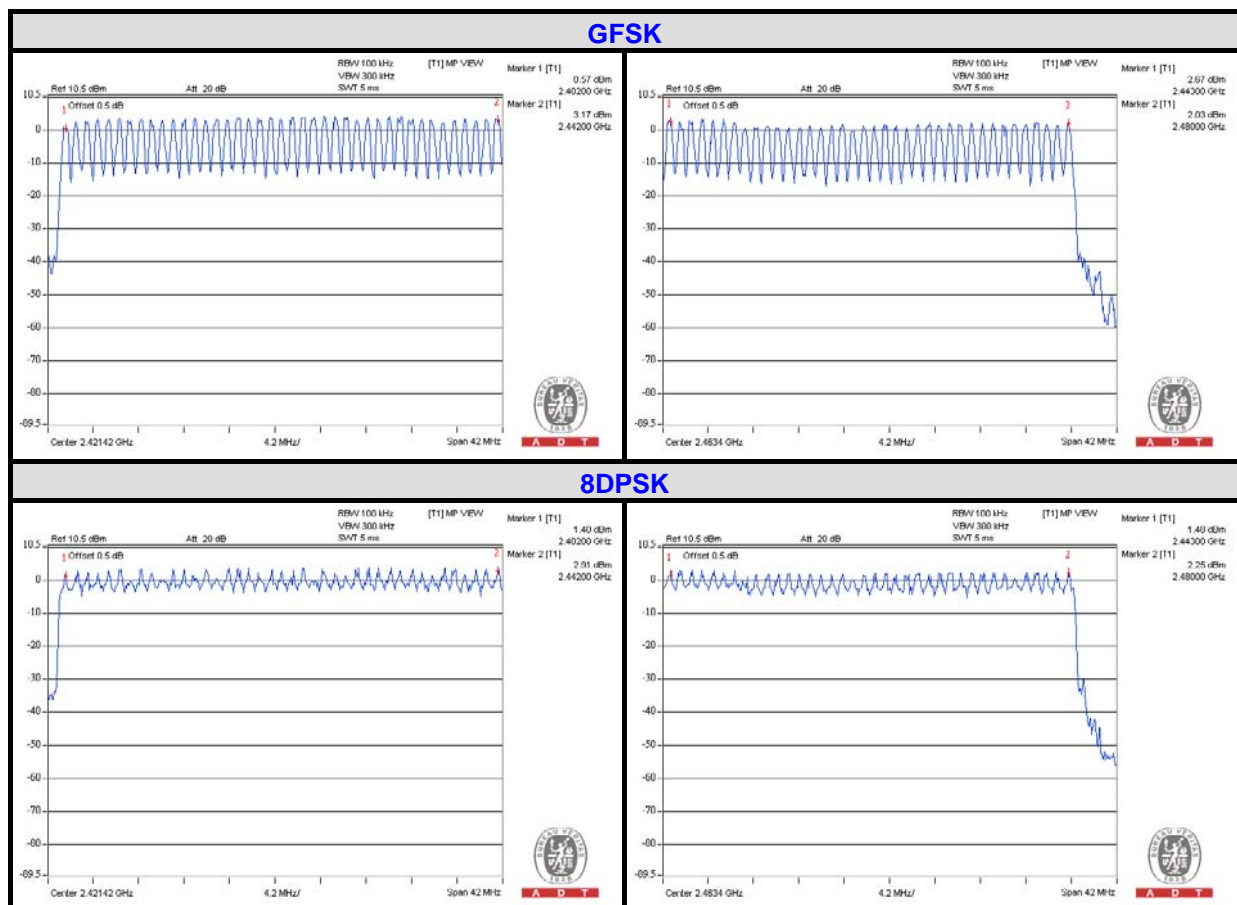

4.4 DWELL TIME ON EACH CHANNEL

4.4.1 LIMIT OF DWELL TIME USED

The average time of occupancy on any channel shall not be greater than 0.4 seconds within a period of 0.4 seconds multiplied by the number of hopping channels employed.

4.4.2 TEST INSTRUMENTS

| DESCRIPTION & MANUFACTURER | MODEL NO. | SERIAL NO. | CALIBRATED DATE | CALIBRATED UNTIL |
|----------------------------|-----------|------------|-----------------|------------------|
| R&S Spectrum Analyzer | FSP40 | 100037 | Nov. 01, 2012 | Oct. 31, 2013 |

Note:

1. The calibration interval of the above test instruments is 12 months and the calibrations are traceable to NML/ROC and NIST/USA.
2. Tested date : Feb. 20, 2013

4.4.3 TEST PROCEDURES

- a. Check the calibration of the measuring instrument (SA) using either an internal calibrator or a known signal from an external generator.
- b. Turn on the EUT and connect its antenna terminal to measurement via a low loss cable. Then set it to any one measured frequency within its operating range and make sure the instrument is operated in its linear range.
- c. Adjust the center frequency of SA on any frequency be measured and set SA to zero span mode. And then, set RBW and VBW of spectrum analyzer to proper value.
- d. Measure the time duration of one transmission on the measured frequency. And then plot the result with time difference of this time duration.
- e. Repeat above procedures until all different time-slot modes have been completed.

4.4.4 DEVIATION FROM TEST STANDARD

No deviation

4.4.5 TEST SETUP

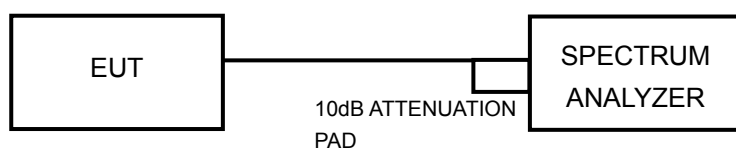

4.4.6 TEST RESULTS

For GFSK:

| Mode | Number of transmission in a 31.6 (79Hopping*0.4) | Length of transmission time (msec) | Result (msec) | Limit (msec) |
|------|--|------------------------------------|---------------|--------------|
| DH1 | 50 (times / 5 sec) *6.32=316 times | 0.45 | 142.2 | 400 |
| DH3 | 25 (times / 5 sec) *6.32=158 times | 1.77 | 279.66 | 400 |
| DH5 | 17 (times / 5 sec) *6.32=107.44 times | 2.97 | 319.1 | 400 |

NOTE: Test plots of the transmitting time slot are shown on next page.



A D T

DH1

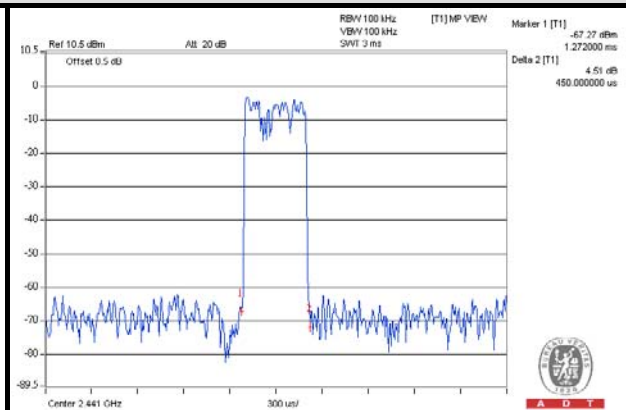
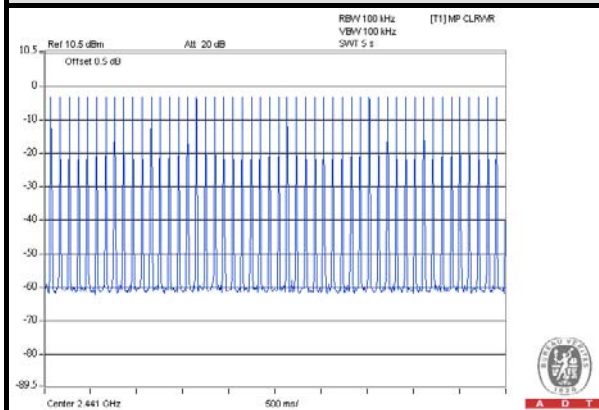

DH3

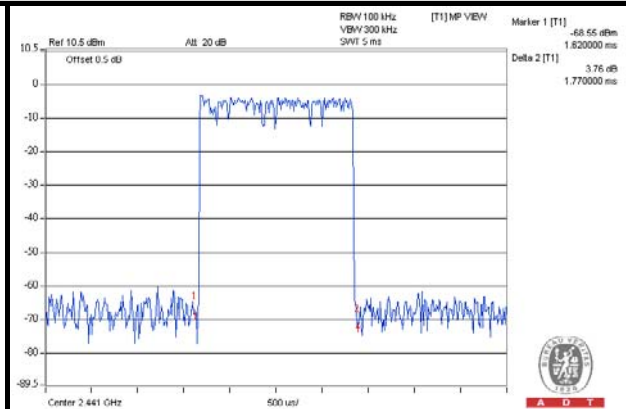
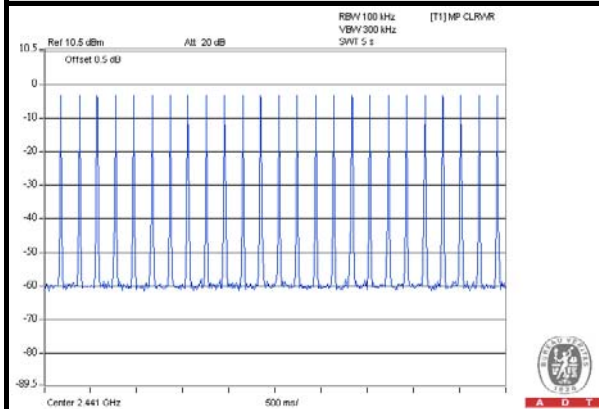

DH5

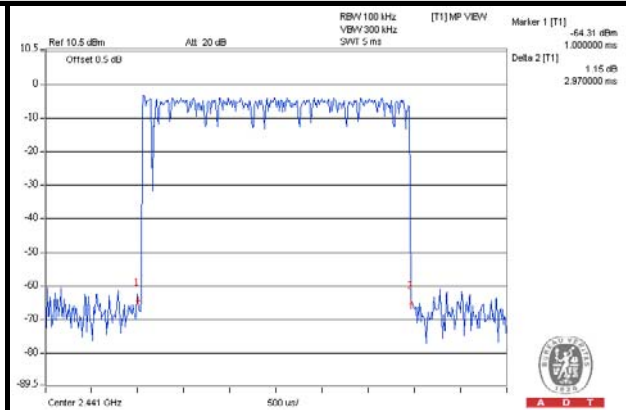
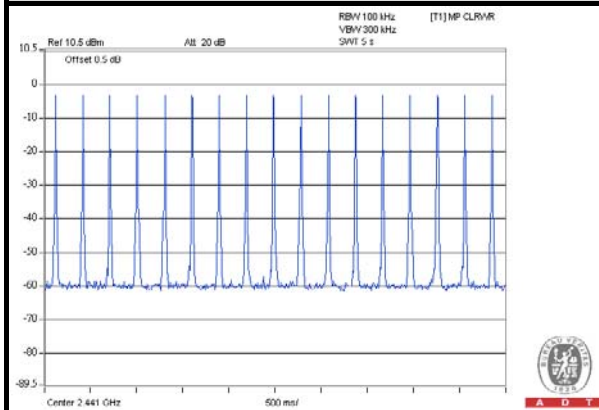



A D T

For 8DPSK:

| Mode | Number of transmission in a 31.6 (79Hopping*0.4) | Length of transmission time (msec) | Result (msec) | Limit (msec) |
|------|--|------------------------------------|---------------|--------------|
| DH1 | 50 (times / 5 sec) *6.32=316 times | 0.486 | 153.58 | 400 |
| DH3 | 25 (times / 5 sec) *6.32=158 times | 1.8 | 284.4 | 400 |
| DH5 | 17 (times / 5 sec) *6.32=107.44 times | 3.01 | 323.39 | 400 |

NOTE: Test plots of the transmitting time slot are shown on next page.



A D T

DH1

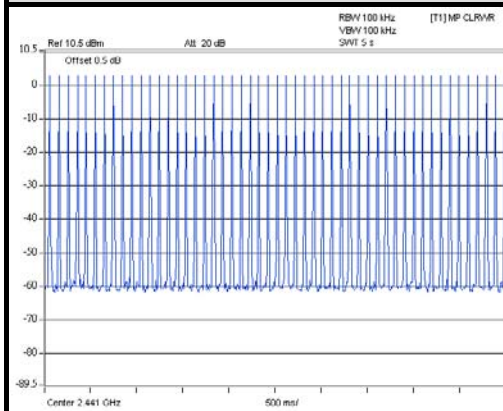

A D T

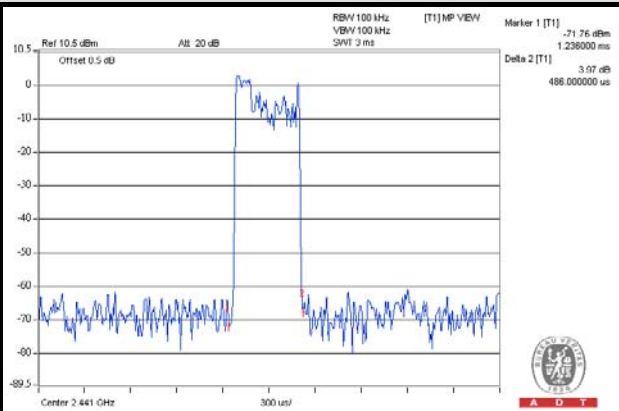

A D T

DH3

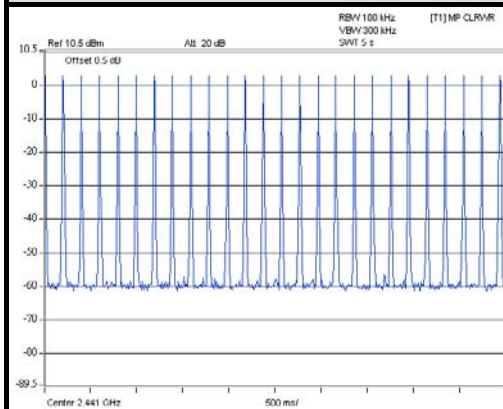

A D T

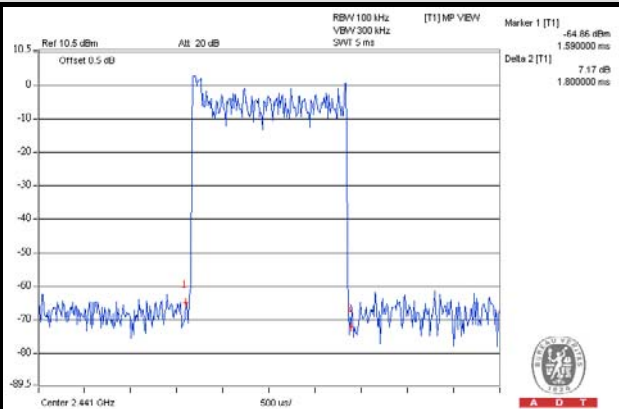

A D T

DH5

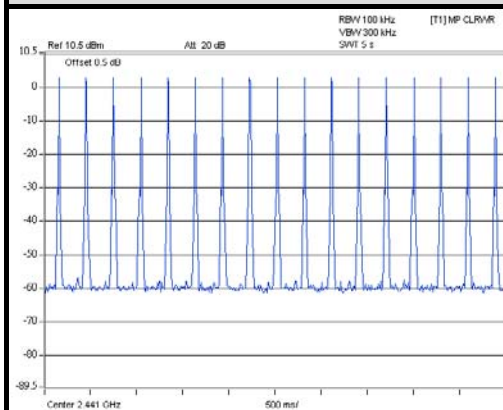

A D T

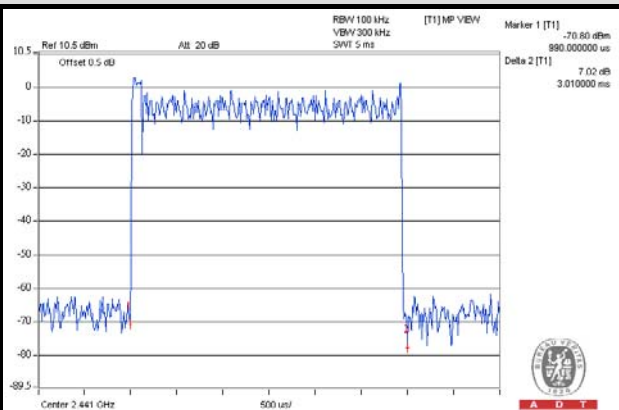

A D T

4.5 CHANNEL BANDWIDTH

4.5.1 LIMITS OF CHANNEL BANDWIDTH

For frequency hopping system operating in the 2400-2483.5MHz, If the 20dB bandwidth of hopping channel is greater than 25kHz, two-thirds 20dB bandwidth of hopping channel shall be a minimum limit for the hopping channel separation.

4.5.2 TEST INSTRUMENTS

| DESCRIPTION & MANUFACTURER | MODEL NO. | SERIAL NO. | CALIBRATED DATE | CALIBRATED UNTIL |
|----------------------------|-----------|------------|-----------------|------------------|
| R&S Spectrum Analyzer | FSP40 | 100037 | Nov. 01, 2012 | Oct. 31, 2013 |

Note:

1. The calibration interval of the above test instruments is 12 months and the calibrations are traceable to NML/ROC and NIST/USA.
2. Tested date : Feb. 20, 2013

4.5.3 TEST PROCEDURE

- a. Check the calibration of the measuring instrument using either an internal calibrator or a known signal from an external generator.
- b. Turn on the EUT and connect it to measurement instrument. Then set it to any one convenient frequency within its operating range. Set a reference level on the measuring instrument equal to the highest peak value.
- c. Measure the frequency difference of two frequencies that were attenuated 20dB from the reference level. Record the frequency difference as the emission bandwidth.
- d. Repeat above procedures until all frequencies measured were complete.

4.5.4 DEVIATION FROM TEST STANDARD

No deviation

4.5.5 TEST SETUP

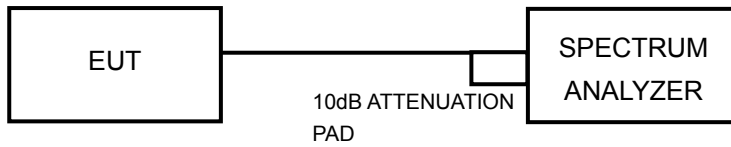

4.5.6 EUT OPERATING CONDITION

The software provided by client enabled the EUT to transmit and receive data at lowest, middle and highest channel frequencies individually.



A D T

4.5.7 TEST RESULTS

| CHANNEL | FREQUENCY (MHz) | 20dB BANDWIDTH (MHz) | |
|---------|-----------------|----------------------|-------|
| | | GFSK | 8DPSK |
| 0 | 2402 | 0.87 | 1.27 |
| 39 | 2441 | 0.87 | 1.25 |
| 78 | 2480 | 0.87 | 1.26 |

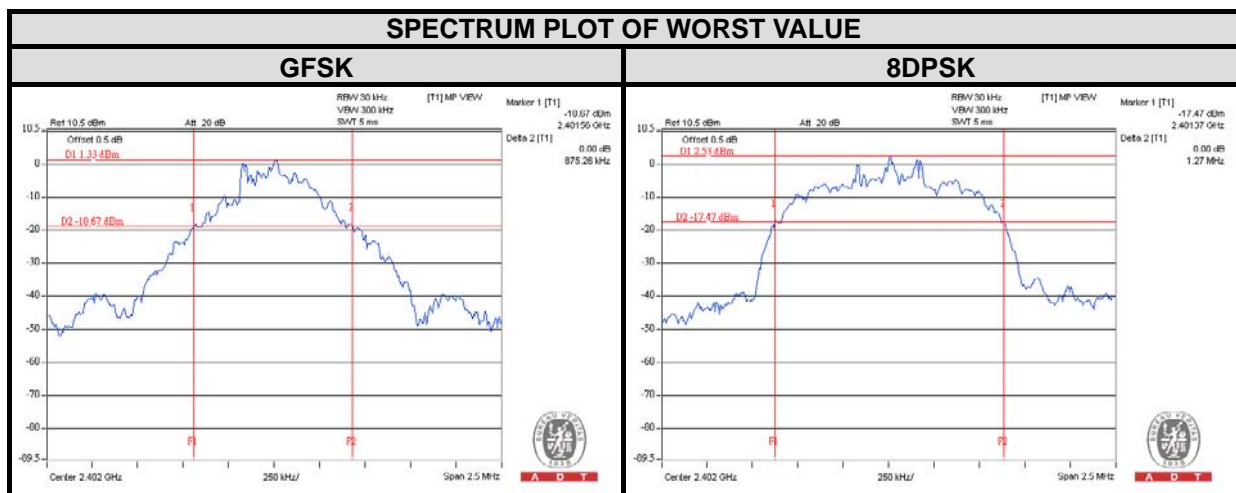

4.6 HOPPING CHANNEL SEPARATION

4.6.1 LIMIT OF HOPPING CHANNEL SEPARATION

At least 25 kHz or two-thirds of 20dB hopping channel bandwidth (whichever is greater).

4.6.2 TEST INSTRUMENTS

| DESCRIPTION & MANUFACTURER | MODEL NO. | SERIAL NO. | CALIBRATED DATE | CALIBRATED UNTIL |
|----------------------------|-----------|------------|-----------------|------------------|
| R&S Spectrum Analyzer | FSP40 | 100037 | Nov. 01, 2012 | Oct. 31, 2013 |

Note:

1. The calibration interval of the above test instruments is 12 months and the calibrations are traceable to NML/ROC and NIST/USA.
2. Tested date : Feb. 20, 2013

4.6.3 TEST PROCEDURES

- a. Check the calibration of the measuring instrument using either an internal calibrator or a known signal from an external generator.
- b. Turn on the EUT and connect it to measurement instrument. Then set it to any one convenient frequency within its operating range.
- c. By using the MaxHold function record the separation of two adjacent channels.
- d. Measure the frequency difference of these two adjacent channels by SA MARK function. And then plot the result on SA screen.
- e. Repeat above procedures until all frequencies measured were complete.

4.6.4 DEVIATION FROM TEST STANDARD

No deviation

4.6.5 TEST SETUP

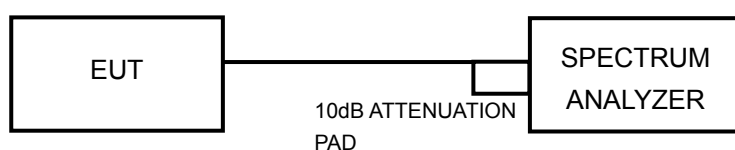



A D T

4.6.6 TEST RESULTS

| CHANNEL | FREQUENCY (MHz) | ADJACENT CHANNEL SEPARATION (MHz) | | 20dB BANDWIDTH (MHz) | | MINIMUM LIMIT (MHz) | | PASS / FAIL |
|---------|-----------------|-----------------------------------|-------|----------------------|-------|---------------------|-------|-------------|
| | | GFSK | 8DPSK | GFSK | 8DPSK | GFSK | 8DPSK | |
| 0 | 2402 | 1.00 | 1.00 | 0.87 | 1.27 | 0.58 | 0.85 | PASS |
| 39 | 2441 | 1.01 | 1.01 | 0.87 | 1.25 | 0.58 | 0.83 | PASS |
| 78 | 2480 | 1.00 | 1.01 | 0.87 | 1.26 | 0.58 | 0.84 | PASS |

NOTE: The minimum limit is two-third 20dB bandwidth.

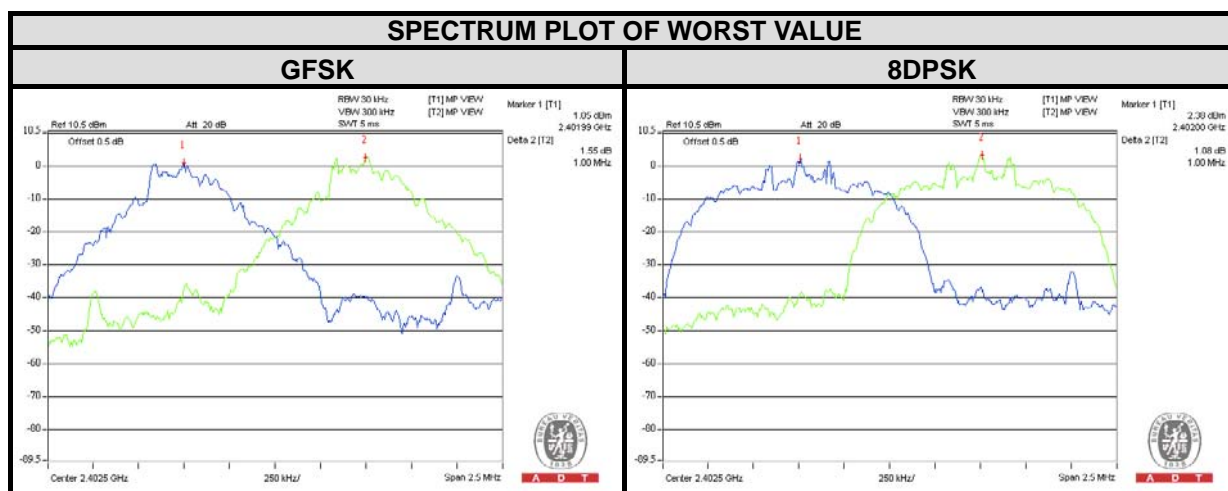

4.7 MAXIMUM PEAK OUTPUT POWER

4.7.1 LIMITS OF MAXIMUM PEAK OUTPUT POWER MEASUREMENT

The Maximum Peak Output Power Limit is 125mW.

4.7.2 INSTRUMENTS

| DESCRIPTION & MANUFACTURER | MODEL NO. | SERIAL NO. | CALIBRATED DATE | CALIBRATED UNTIL |
|----------------------------|-----------|------------|-----------------|------------------|
| R&S Spectrum Analyzer | FSP40 | 100037 | Nov. 01, 2012 | Oct. 31, 2013 |

Note:

1. The calibration interval of the above test instruments is 12 months and the calibrations are traceable to NML/ROC and NIST/USA.
2. Tested date : Feb. 20, 2013

4.7.3 TEST PROCEDURES

- a. Check the calibration of the measuring instrument using either an internal calibrator or a known signal from an external generator.
- b. Turn on the EUT and connect it to measurement instrument. Then set it to any one convenient frequency within its operating range. Set a reference level on the measuring instrument equal to the highest peak value.
- c. The center frequency of the spectrum analyzer is set to the fundamental frequency and using 3MHz RBW and 10 MHz VBW.
- d. Measure the captured power within the band and recording the plot.
- e. Repeat above procedures until all frequencies required were complete.

4.7.4 DEVIATION FROM TEST STANDARD

No deviation

4.7.5 TEST SETUP

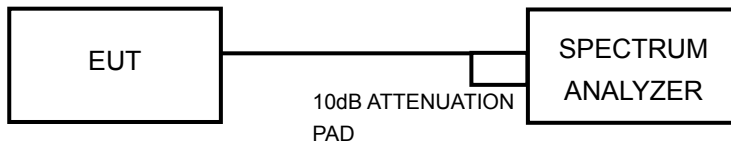

For the actual test configuration, please refer to the related Item – Photographs of the Test Configuration.

4.7.6 EUT OPERATING CONDITION

The software provided by client enabled the EUT to transmit and receive data at lowest, middle and highest channel frequencies individually.

4.7.7 TEST RESULTS

| CHANNEL | FREQUENCY (MHz) | OUTPUT POWER (mW) | | OUTPUT POWER (dBm) | | POWER LIMIT (mW) | PASS / FAIL |
|---------|-----------------|-------------------|-------|--------------------|-------|------------------|-------------|
| | | GFSK | 8DPSK | GFSK | 8DPSK | | |
| 0 | 2402 | 2.018 | 4.498 | 3.05 | 6.53 | 125 | PASS |
| 39 | 2441 | 2.793 | 3.573 | 4.46 | 5.53 | 125 | PASS |
| 78 | 2480 | 2.168 | 3.236 | 3.36 | 5.10 | 125 | PASS |

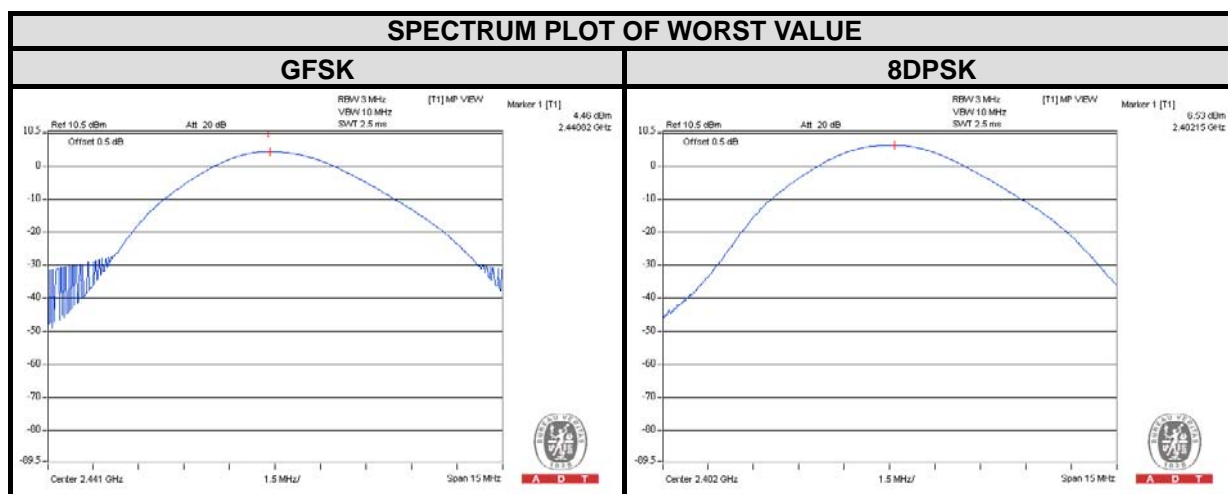

4.8 CONDUCTED OUT-BAND EMISSION MEASUREMENT

4.8.1 LIMITS OF CONDUCTED OUT-BAND EMISSION MEASUREMENT

Below 20dB of the highest emission level of operating band (in 100kHz Resolution Bandwidth).

4.8.2 TEST INSTRUMENTS

| DESCRIPTION & MANUFACTURER | MODEL NO. | SERIAL NO. | CALIBRATED DATE | CALIBRATED UNTIL |
|----------------------------|-----------|------------|-----------------|------------------|
| R&S Spectrum Analyzer | FSP40 | 100037 | Nov. 01, 2012 | Oct. 31, 2013 |

Note:

1. The calibration interval of the above test instruments is 12 months and the calibrations are traceable to NML/ROC and NIST/USA.
2. Tested date : Feb. 20, 2013

4.8.3 TEST PROCEDURE

The transmitter output was connected to the spectrum analyzer via a low lose cable. Set RBW a of spectrum analyzer to 100 kHz and VBW of spectrum analyzer to 300 kHz with suitable frequency span including 100 MHz bandwidth from band edge. The band edges was measured and recorded.

4.8.4 DEVIATION FROM TEST STANDARD

No deviation

4.8.5 TEST SETUP

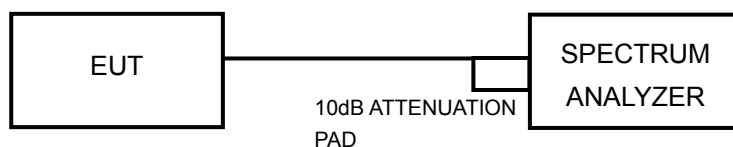

4.8.6 EUT OPERATING CONDITION

The software provided by client enabled the EUT to transmit and receive data at lowest, middle and highest channel frequencies individually.

4.8.7 TEST RESULTS

The spectrum plots are attached on the following images. D1 line indicates the highest level, and D2 line indicates the 20dB offset below D1. It shows compliance with the requirement.



A D T

For GFSK

Hopping disabled_Low Channel

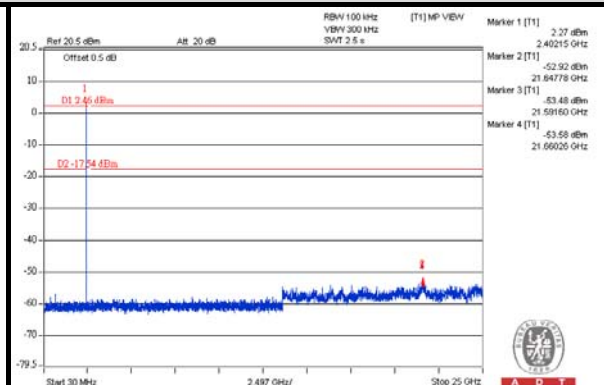
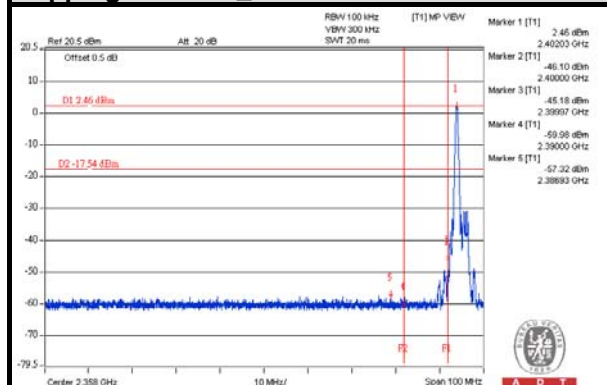

Hopping disabled_High Channel

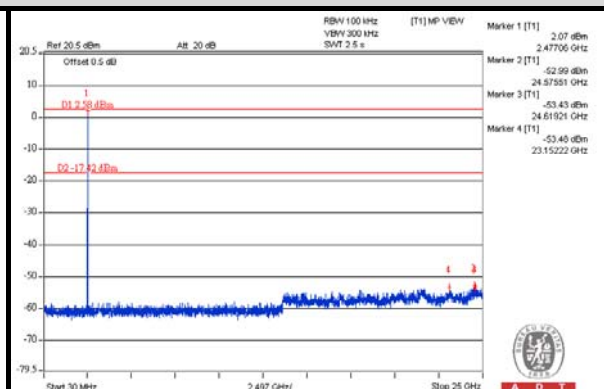
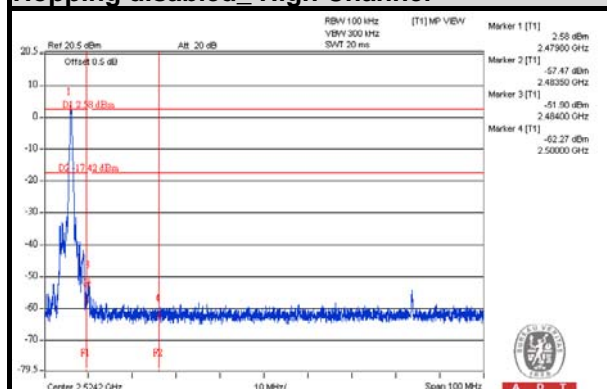

Hopping enabled_Low Channel

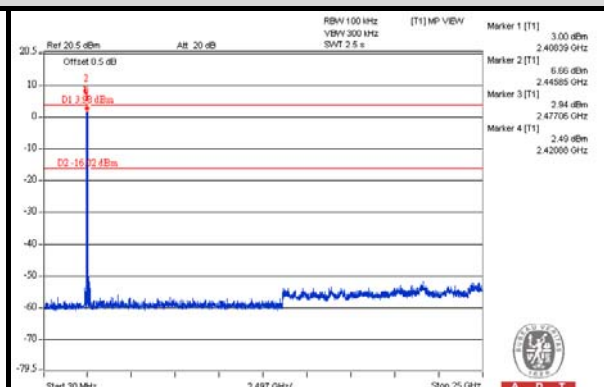
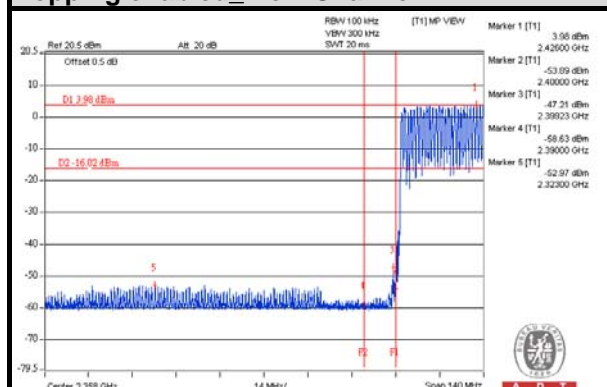

Hopping enabled_High Channel

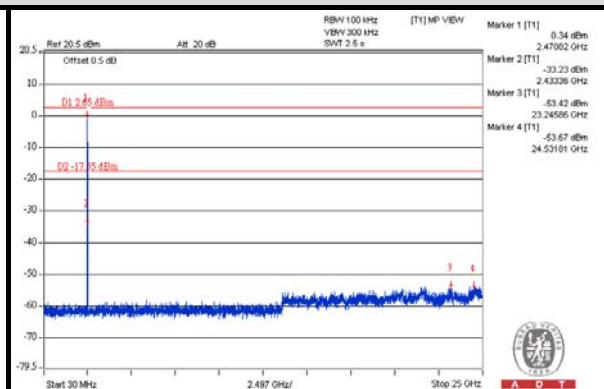
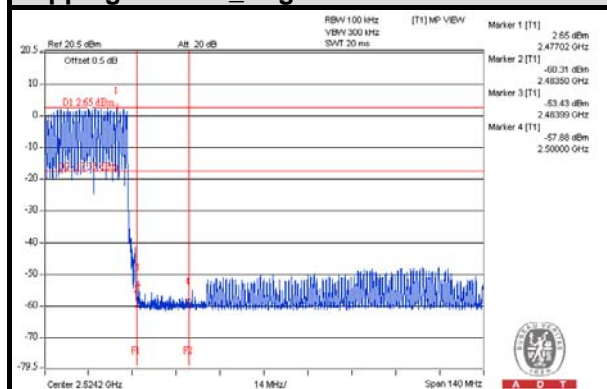



A D T

For 8DPSK

Hopping disabled_Low Channel

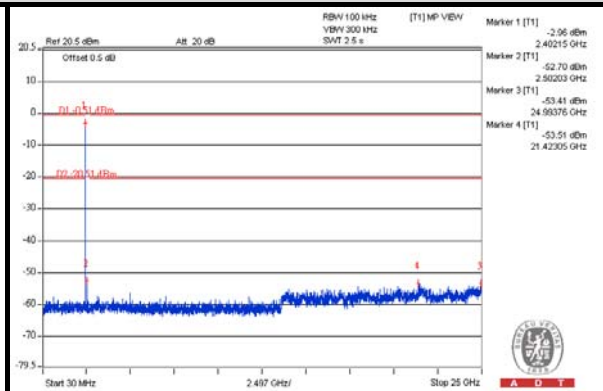
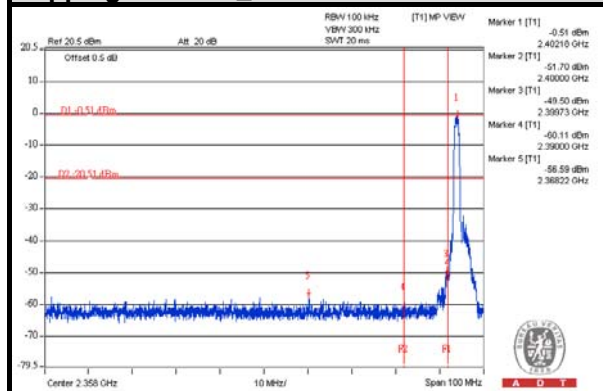

Hopping disabled_High Channel

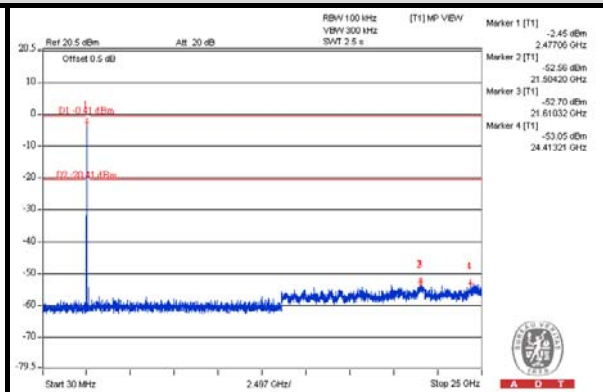
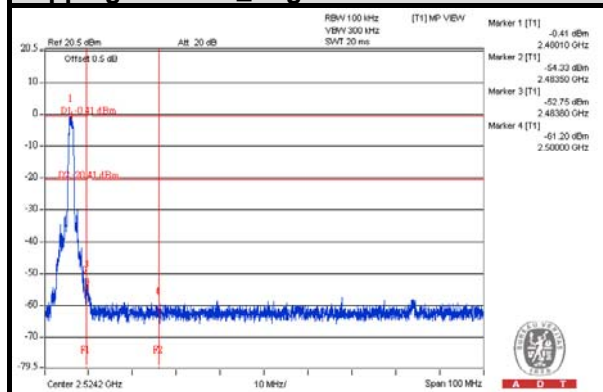

Hopping enabled_Low Channel

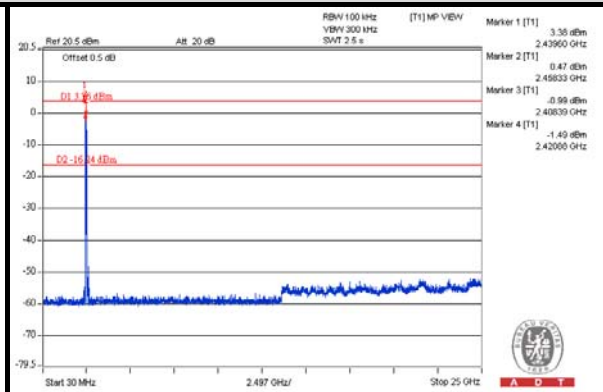
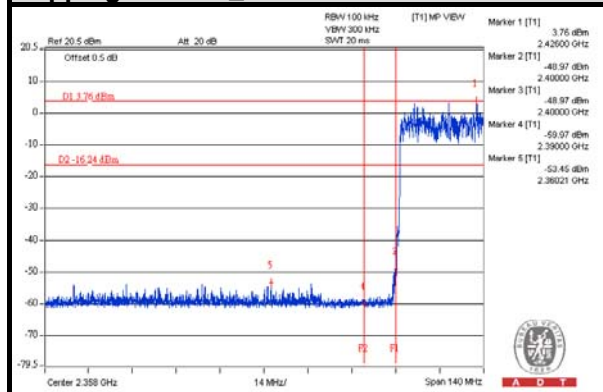

Hopping enabled_High Channel

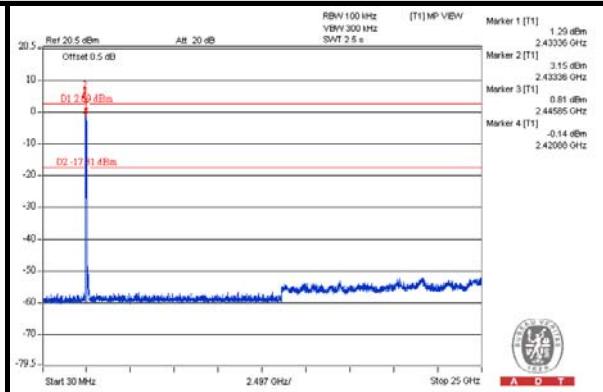
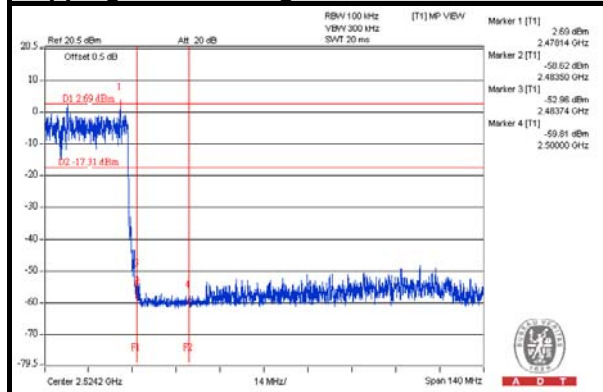



5 PHOTOGRAPHS OF THE TEST CONFIGURATION

Please refer to the attached file (Test Setup Photo).



6 INFORMATION ON THE TESTING LABORATORIES

We, Bureau Veritas Consumer Products Services (H.K.) Ltd., Taoyuan Branch, were founded in 1988 to provide our best service in EMC, Radio, Telecom and Safety consultation. Our laboratories are accredited and approved according to ISO/IEC 17025.

If you have any comments, please feel free to contact us at the following:

Linko EMC/RF Lab:

Tel: 886-2-26052180

Fax: 886-2-26052943

Hsin Chu EMC/RF Lab:

Tel: 886-3-5935343

Fax: 886-3-5935342

Hwa Ya EMC/RF/Safety/Telecom Lab:

Tel: 886-3-3183232

Fax: 886-3-3270892

Email: service.adt@tw.bureauveritas.com

Web Site: www.bureauveritas-adt.com

The address and road map of all our labs can be found in our web site also.

7 APPENDIX A - MODIFICATIONS RECORDERS FOR ENGINEERING CHANGES TO THE EUT BY THE LAB

No modifications were made to the EUT by the lab during the test.

--- END ---