



FCC TEST REPORT

REPORT NO.: RF120530E04

MODEL NO.: S-00120

FCC ID: JNZS00120

RECEIVED: May 30, 2012

TESTED: May 31 to June 04, 2012

ISSUED: June 14, 2012

APPLICANT: LOGITECH FAR EAST LTD.

ADDRESS: #2 Creation Rd. 4, Science-Based Ind. Park
Hsinchu Taiwan, R.O.C.

ISSUED BY: Bureau Veritas Consumer Products Services (H.K.)
Ltd., Taoyuan Branch Hsin Chu Laboratory

LAB ADDRESS: No. 81-1, Lu Liao Keng, 9th Ling, Wu Lung Tsuen,
Chiung Lin Hsiang, Hsin Chu Hsien 307, Taiwan,
R.O.C.

TEST LOCATION (1): No. 81-1, Lu Liao Keng, 9th Ling, Wu Lung Tsuen,
Chiung Lin Hsiang, Hsin Chu Hsien 307, Taiwan,
Taiwan, R.O.C.

TEST LOCATION (2): No.49, Ln. 206, Wende Rd., Shangshan Tsuen,
Chiung Lin Hsiang, Hsin Chu Hsien 307, Taiwan,
Taiwan, R.O.C.

This report should not be used by the client to claim product certification, approval, or endorsement by TAF or any government agencies.



This report is for your exclusive use. Any copying or replication of this report to or for any other person or entity, or use of our name or trademark, is permitted only with our prior written permission. This report sets forth our findings solely with respect to the test samples identified herein. The results set forth in this report are not indicative or representative of the quality or characteristics of the lot from which a test sample was taken or any similar or identical product unless specifically and expressly noted. Our report includes all of the tests requested by you and the results thereof based upon the information that you provided to us. You have 60 days from date of issuance of this report to notify us of any material error or omission caused by our negligence, provided, however, that such notice shall be in writing and shall specifically address the issue you wish to raise. A failure to raise such issue within the prescribed time shall constitute your unqualified acceptance of the completeness of this report, the tests conducted and the correctness of the report contents. Unless specific mention, the uncertainty of measurement has been explicitly taken into account to declare the compliance or non-compliance to the specification



TABLE OF CONTENTS

RELEASE CONTROL RECORD	4
1 CERTIFICATION	5
2 SUMMARY OF TEST RESULTS.....	6
2.1 MEASUREMENT UNCERTAINTY	7
3 GENERAL INFORMATION	8
3.1 GENERAL DESCRIPTION OF EUT	8
3.2 DESCRIPTION OF TEST MODES.....	10
3.3 TEST MODE APPLICABILITY AND TESTED CHANNEL DETAIL:	11
3.4 GENERAL DESCRIPTION OF APPLIED STANDARDS	13
3.5 DESCRIPTION OF SUPPORT UNITS	14
3.6 CONFIGURATION OF SYSTEM UNDER TEST.....	15
4 TEST PROCEDURES AND RESULTS	16
4.1 CONDUCTED EMISSION MEASUREMENT	16
4.1.1 LIMITS OF CONDUCTED EMISSION MEASUREMENT	16
4.1.2 TEST INSTRUMENTS.....	16
4.1.3 TEST PROCEDURES	17
4.1.4 TEST SETUP	17
4.1.5 EUT OPERATING CONDITIONS.....	18
4.1.6 TEST RESULTS	19
4.2 RADIATED EMISSION AND BANDEDGE MEASUREMENT.....	21
4.2.1 LIMITS OF RADIATED EMISSION AND BANDEDGE MEASUREMENT.....	21
4.2.2 TEST INSTRUMENTS.....	22
4.2.3 TEST PROCEDURES	24
4.2.4 DEVIATION FROM TEST STANDARD	24
4.2.5 TEST SETUP	25
4.2.6 EUT OPERATING CONDITIONS.....	25
4.2.7 TEST RESULTS	26
4.3 NUMBER OF HOPPING FREQUENCY USED	33
4.3.1 LIMIT OF HOPPING FREQUENCY USED	33
4.3.2 TEST INSTRUMENTS.....	33
4.3.3 TEST PROCEDURES	33
4.3.4 DEVIATION FROM TEST STANDARD	33
4.3.5 TEST SETUP	34
4.3.6 TEST RESULTS	34
4.4 DWELL TIME ON EACH CHANNEL	37
4.4.1 LIMIT OF DWELL TIME USED	37
4.4.2 TEST INSTRUMENTS.....	37
4.4.3 TEST PROCEDURES	37
4.4.4 DEVIATION FROM TEST STANDARD	38
4.4.5 TEST SETUP	38
4.4.6 TEST RESULTS	39



A D T

4.5	CHANNEL BANDWIDTH	47
4.5.1	LIMITS OF CHANNEL BANDWIDTH	47
4.5.2	TEST INSTRUMENTS	47
4.5.3	TEST PROCEDURE	47
4.5.4	DEVIATION FROM TEST STANDARD	47
4.5.5	TEST SETUP	48
4.5.6	EUT OPERATING CONDITION	48
4.5.7	TEST RESULTS	49
4.6	HOPPING CHANNEL SEPARATION	51
4.6.1	LIMIT OF HOPPING CHANNEL SEPARATION	51
4.6.2	TEST INSTRUMENTS	51
4.6.3	TEST PROCEDURES	51
4.6.4	DEVIATION FROM TEST STANDARD	51
4.6.5	TEST SETUP	51
4.6.6	TEST RESULTS	52
4.7	MAXIMUM PEAK OUTPUT POWER	54
4.7.1	LIMITS OF MAXIMUM PEAK OUTPUT POWER MEASUREMENT	54
4.7.2	INSTRUMENTS	54
4.7.3	TEST PROCEDURES	54
4.7.4	DEVIATION FROM TEST STANDARD	54
4.7.5	TEST SETUP	55
4.7.6	EUT OPERATING CONDITION	55
4.7.7	TEST RESULTS	56
4.8	CONDUCTED OUT-BAND EMISSION MEASUREMENT	58
4.8.1	LIMITS OF CONDUCTED OUT-BAND EMISSION MEASUREMENT	58
4.8.2	TEST INSTRUMENTS	58
4.8.3	TEST PROCEDURE	58
4.8.4	DEVIATION FROM TEST STANDARD	58
4.8.5	EUT OPERATING CONDITION	58
4.8.6	TEST RESULTS	59
5	PHOTOGRAPHS OF THE TEST CONFIGURATION	62
6	INFORMATION ON THE TESTING LABORATORIES	63
7	APPENDIX A - MODIFICATIONS RECORDERS FOR ENGINEERING CHANGES TO THE EUT BY THE LAB	64



A D T

RELEASE CONTROL RECORD

ISSUE NO.	REASON FOR CHANGE	DATE ISSUED
RF120530E04	Original release	June 14, 2012



1 CERTIFICATION

PRODUCT : Bluetooth Speaker (Logitech UE Mobile Boombox)
BRAND NAME : Logitech, Ue, Logitech | Ue
MODEL NO. : S-00120
TEST SAMPLE : ENGINEERING SAMPLE
APPLICANT : LOGITECH FAR EAST LTD.
TESTED DATE : May 31 to June 04, 2012
STANDARDS : FCC Part 15, Subpart C (Section 15.247)
ANSI C63.10-2009

The above equipment (Model: S-00120) has been tested by **Bureau Veritas Consumer Products Services (H.K.) Ltd., Taoyuan Branch**, and found compliance with the requirement of the above standards. The test record, data evaluation & Equipment Under Test (EUT) configurations represented herein are true and accurate accounts of the measurements of the sample's EMC characteristics under the conditions specified in this report.

PREPARED BY :  , **DATE:** June 14, 2012
(Elsie Hsu, Specialist)

APPROVED BY :  , **DATE:** June 14, 2012
(May Chen, Deputy Manager)



2 SUMMARY OF TEST RESULTS

The EUT has been tested according to the following specifications:

APPLIED STANDARD: FCC Part 15, Subpart C			
STANDARD SECTION	TEST TYPE AND LIMIT	RESULT	REMARK
15.207	AC Power Conducted Emission	PASS	Meet the requirement of limit. Minimum passing margin is -7.47dB at 3.20703MHz.
15.247(a)(1) (iii)	Number of Hopping Frequency Used	PASS	Meet the requirement of limit.
15.247(a)(1) (iii)	Dwell Time on Each Channel	PASS	Meet the requirement of limit.
15.247(a)(1)	1. Hopping Channel Separation 2. Spectrum Bandwidth of a Frequency Hopping Sequence Spread Spectrum System	PASS	Meet the requirement of limit.
15.247(b)	Maximum Peak Output Power	PASS	Meet the requirement of limit.
15.247(d)	Transmitter Radiated Emissions	PASS	Meet the requirement of limit. Minimum passing margin is -4.4dB at 4882.00MHz.
15.247(d)	Band Edge Measurement	PASS	Meet the requirement of limit.
15.203	Antenna Requirement	PASS	No antenna connector is used.

NOTE:

1. Frequency Hopping System operating in 2400-2483.5MHz band and the output power less than 125mW. The hopping channel carrier frequencies separated by a minimum of 25kHz or two-thirds of the 20dB bandwidth of hopping channel whichever is greater.

2.1 MEASUREMENT UNCERTAINTY

Where relevant, the following measurement uncertainty levels have been estimated for tests performed on the EUT as specified in CISPR 16-4-2:

This uncertainty represents an expanded uncertainty expressed at approximately the 95% confidence level using a coverage factor of $k=2$.

MEASUREMENT	FREQUENCY	UNCERTAINTY
Conducted emissions	150kHz ~ 30MHz	2.98dB
Radiated emissions	30MHz ~ 1000MHz	5.59 dB
	1GHz ~ 6GHz	3.84 dB
	6GHz ~ 18GHz	4.09 dB
	18GHz ~ 40GHz	4.24 dB

The listed uncertainties are the worst case uncertainty for the entire range of measurement. Please note that the uncertainty values are provided for informational purposes only and are not used in determining the PASS/FAIL results.



A D T

3 GENERAL INFORMATION

3.1 GENERAL DESCRIPTION OF EUT

PRODUCT	Bluetooth Speaker (Logitech UE Mobile Boombox)
MODEL NO.	S-00120
POWER SUPPLY	DC 3.7V from battery or DC 5.15V from power adapter
MODULATION TYPE	GFSK, $\pi/4$ -DQPSK, 8DPSK
MODULATION TECHNOLOGY	FHSS
DATE RATE	Up to 3Mbps
FREQUENCY RANGE	2402MHz ~ 2480MHz
NUMBER OF CHANNEL	79
MAX. OUTPUT POWER	1.403mW
ANTENNA TYPE	Please see NOTE
DATA CABLE	USB cable (shielded, 0.7m) x 1
I/O PORTS	Refer to user's manual
ASSOCIATED DEVICES	Adapter x 1



NOTE:

1. The EUT has three brand names which are identical to each other in all aspects except for the following table:

Brand	Model Name
Logitech	S-00120
Ue	
Logitech Ue	

2. The antenna provided to the EUT, please refer to the following table:

Model	Antenna Type	Freq. range (MHz)	Gain (dBi)
NA	Wire formed, Quarter Wavelength Monopole	2400-2500	0.22

3. The EUT must be supplied with a battery or a adapter, please refer to the following table:

Battery		
Brand	L/N	Spec.
Logitech	1205	DC: 3.7~4.2V, 1100mAh
Adapter		
Brand	Model No.	Spec.
Logitech	AD6313C	AC Input: 100-240V, 0.13A, 50/60Hz DC Output: 5.15Vdc, 1A

4. The EUT was pre-tested under following test modes :

Test Mode	Description
Mode A	EUT only
Mode B	EUT + Adapter
Mode C	EUT + NB

For the above modes, the worst radiated test was found in **Mode C**. Therefore only the test data of the modes were recorded in this report.

5. The above EUT information was declared by the manufacturer and for more detailed feature descriptions, please refer to the manufacturer's specifications or User's Manual.



3.2 DESCRIPTION OF TEST MODES

79 channels are provided for Bluetooth.

Channel	Freq. (MHz)	Channel	Freq. (MHz)	Channel	Freq. (MHz)	Channel	Freq. (MHz)
0	2402	20	2422	40	2442	60	2462
1	2403	21	2423	41	2443	61	2463
2	2404	22	2424	42	2444	62	2464
3	2405	23	2425	43	2445	63	2465
4	2406	24	2426	44	2446	64	2466
5	2407	25	2427	45	2447	65	2467
6	2408	26	2428	46	2448	66	2468
7	2409	27	2429	47	2449	67	2469
8	2410	28	2430	48	2450	68	2470
9	2411	29	2431	49	2451	69	2471
10	2412	30	2432	50	2452	70	2472
11	2413	31	2433	51	2453	71	2473
12	2414	32	2434	52	2454	72	2474
13	2415	33	2435	53	2455	73	2475
14	2416	34	2436	54	2456	74	2476
15	2417	35	2437	55	2457	75	2477
16	2418	36	2438	56	2458	76	2478
17	2419	37	2439	57	2459	77	2479
18	2420	38	2440	58	2460	78	2480
19	2421	39	2441	59	2461		



3.3 TEST MODE APPLICABILITY AND TESTED CHANNEL DETAIL:

EUT CONFIGURE MODE	APPLICABLE TO					DESCRIPTION
	PLC	RE < 1G	RE ≥ 1G	APCM	OB	
-	-	√	√	√	√	EUT + NB
-	√	-	-	-	-	EUT + Adapter

Where **PLC**: Power Line Conducted Emission **RE < 1G**: Radiated Emission below 1GHz
RE ≥ 1G: Radiated Emission above 1GHz **APCM**: Antenna Port Conducted Measurement
OB: Conducted Out-Band Emission Measurement

NOTE: The EUT had been pre-tested on the positioned of each 3 axis. The radiated emission below 1GHz worst case was found when positioned on **Y-plane**. The radiated emission above 1GHz worst case was found when positioned on **X-plane**.

POWER LINE CONDUCTED EMISSION TEST:

- Pre-Scan has been conducted to determine the worst-case mode from all possible combinations between available modulations, data rates and antenna ports (if EUT with antenna diversity architecture).
- Following channel(s) was (were) selected for the final test as listed below.

Available Channel	Tested Channel	Modulation Technology	Modulation Type	Packet Type
0 to 78	39	FHSS	GFSK	DH5

RADIATED EMISSION TEST (BELOW 1 GHZ):

- Pre-Scan has been conducted to determine the worst-case mode from all possible combinations between available modulations, data rates and antenna ports (if EUT with antenna diversity architecture).
- Following channel(s) was (were) selected for the final test as listed below.

Available Channel	Tested Channel	Modulation Technology	Modulation Type	Packet Type
0 to 78	39	FHSS	GFSK	DH5

RADIATED EMISSION TEST (ABOVE 1 GHZ):

- Pre-Scan has been conducted to determine the worst-case mode from all possible combinations between available modulations, data rates and antenna ports (if EUT with antenna diversity architecture).
- Following channel(s) was (were) selected for the final test as listed below.

Available Channel	Tested Channel	Modulation Technology	Modulation Type	Packet Type
0 to 78	0, 39, 78	FHSS	GFSK	DH5
0 to 78	0, 39, 78	FHSS	8DPSK	DH5

ANTENNA PORT CONDUCTED MEASUREMENT:

- Pre-Scan has been conducted to determine the worst-case mode from all possible combinations between available modulations, data rates and antenna ports (if EUT with antenna diversity architecture).
- Following channel(s) was (were) selected for the final test as listed below.

Available Channel	Tested Channel	Modulation Technology	Modulation Type	Packet Type
0 to 78	0, 39, 78	FHSS	GFSK	DH5
0 to 78	0, 39, 78	FHSS	8DPSK	DH5

CONDUCTED OUT-BAND EMISSION MEASUREMENT:

- Pre-Scan has been conducted to determine the worst-case mode from all possible combinations between available modulations, data rates and antenna ports (if EUT with antenna diversity architecture).
- Following channel(s) was (were) selected for the final test as listed below.

Available Channel	Tested Channel	Modulation Technology	Modulation Type	Packet Type
0 to 78	0, 39, 78	FHSS	GFSK	DH5
0 to 78	0, 39, 78	FHSS	8DPSK	DH5

TEST CONDITION:

APPLICABLE TO	ENVIRONMENTAL CONDITIONS	INPUT POWER	TESTED BY
PLC	26deg. C, 74%RH,	120Vac, 60Hz	Kyle Huang
RE<1G	24deg. C, 71%RH	120Vac, 60Hz (SYSTEM)	Robert Cheng
RE ³ 1G	26deg. C, 71%RH	120Vac, 60Hz (SYSTEM)	Evan Huang
APCM	25deg. C, 60%RH	120Vac, 60Hz (SYSTEM)	Rex Huang
OB	25deg. C, 60%RH	120Vac, 60Hz (SYSTEM)	Rex Huang



3.4 GENERAL DESCRIPTION OF APPLIED STANDARDS

The EUT is a RF product. According to the specifications of the manufacturer, it must comply with the requirements of the following standards:

FCC Part 15, Subpart C. (15.247)

ANSI C63.10-2009

All test items have been performed and recorded as per the above standards.

Note: The EUT has been verified to comply with the requirements of FCC Part 15, Subpart B, Class B (DoC). The test report has been issued separately.

3.5 DESCRIPTION OF SUPPORT UNITS

The EUT has been tested as an independent unit together with other necessary accessories or support units. The following support units or accessories were used to form a representative test configuration during the tests.

For conducted emission test					
NO.	PRODUCT	BRAND	MODEL NO.	SERIAL NO.	FCC ID
1	iPod	Apple	A1199	6U6425Z8VQ5	NA
For other test items					
NO.	PRODUCT	BRAND	MODEL NO.	SERIAL NO.	FCC ID
1	NOTEBOOK COMPUTER	DELL	PP32LA	GSLB32S	FCC DoC
2	iPod	Apple	MC749TA/A	CC4DMFJUDFDM	NA
3	iPod	Apple	MC749TA/A	CC4DN29UDFDM	NA

For conducted emission test	
NO.	SIGNAL CABLE DESCRIPTION OF THE ABOVE SUPPORT UNITS
1	USB cable (0.7m)
For other test items	
NO.	SIGNAL CABLE DESCRIPTION OF THE ABOVE SUPPORT UNITS
1	USB cable (0.7m)
2	USB cable (0.1m)
3	Audio cable (2.5m)

NOTE: All power cords of the above support units are non shielded (1.8m).

3.6 CONFIGURATION OF SYSTEM UNDER TEST

For conducted emission test

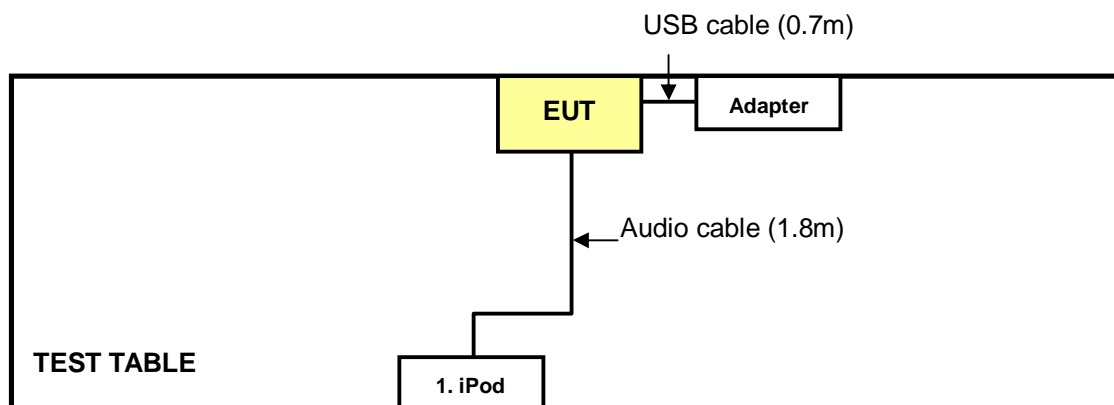

For other test items

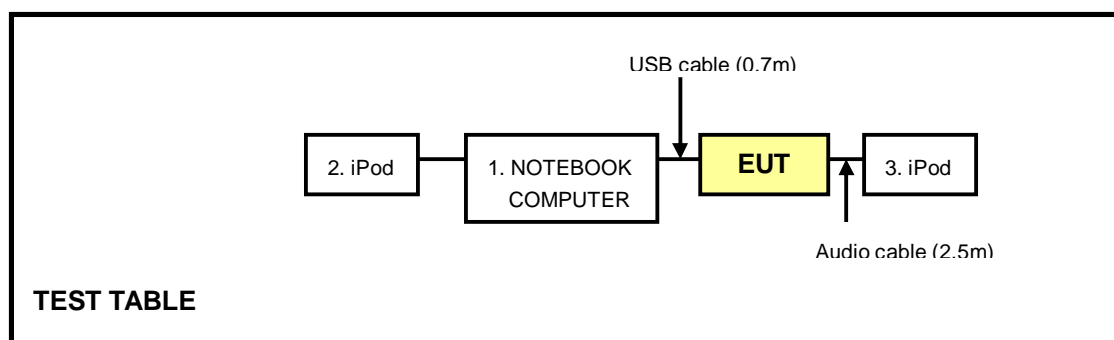

4 TEST PROCEDURES AND RESULTS

4.1 CONDUCTED EMISSION MEASUREMENT

4.1.1 LIMITS OF CONDUCTED EMISSION MEASUREMENT

FREQUENCY OF EMISSION (MHz)	CONDUCTED LIMIT (dB μ V)	
	Quasi-peak	Average
0.15 ~ 0.5	66 to 56	56 to 46
0.5 ~ 5	56	46
5 ~ 30	60	50

- NOTE:** 1. The lower limit shall apply at the transition frequencies.
 2. The limit decreases in line with the logarithm of the frequency in the range of 0.15 to 0.50MHz.

4.1.2 TEST INSTRUMENTS

DESCRIPTION & MANUFACTURER	MODEL NO.	SERIAL NO.	CALIBRATED DATE	CALIBRATED UNTIL
ROHDE & SCHWARZ Test Receiver	ESCS 30	100287	Feb. 29, 2012	Feb. 28, 2013
Line-Impedance Stabilization Network (for EUT)	NSLK 8127	8127-523	Sep. 20, 2011	Sep. 19, 2012
Line-Impedance Stabilization Network (for Peripheral)	ENV-216	100072	June 10, 2011	June 09, 2012
RF Cable (JYBAO)	5DFB	COACAB-002	Aug. 06, 2011	Aug. 05, 2012
50 ohms Terminator	50	3	Nov. 02, 2011	Nov. 01, 2012
Software	BV ADT_Cond_V7.3.7	NA	NA	NA

Note:

1. The calibration interval of the above test instruments is 12 months and the calibrations are traceable to NML/ROC and NIST/USA.
2. The test was performed in Shielded Room No. A.
3. The VCCI Con A Registration No. is C-817.
4. Tested date: June 01, 2012

4.1.3 TEST PROCEDURES

- a. The EUT was placed 0.4 meters from the conducting wall of the shielded room with EUT being connected to the power mains through a line impedance stabilization network (LISN). Other support units were connected to the power mains through another LISN. The two LISNs provide 50 ohm/ 50uH of coupling impedance for the measuring instrument.
- b. Both lines of the power mains connected to the EUT were checked for maximum conducted interference.
- c. The frequency range from 150kHz to 30MHz was searched. Emission levels under (Limit - 20dB) was not recorded.

4.1.4 TEST SETUP

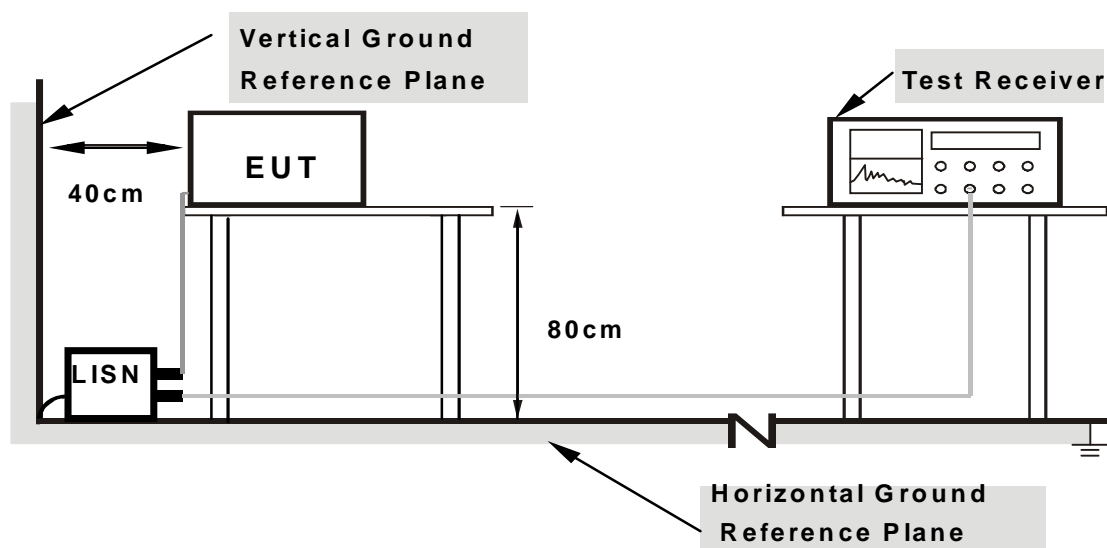

- Note:**
1. Support units were connected to second LISN.
 2. Both of LISNs (AMN) are 80 cm from EUT and at least 80 from other units and other metal planes

For the actual test configuration, please refer to the attached file (Test Setup Photo).

4.1.5 EUT OPERATING CONDITIONS

1. Turn on the power of all equipment.
2. EUT plays music from support unit 1 (iPod) via an audio cable.



4.1.6 TEST RESULTS TEST RESULTS

PHASE	Line (L)	6dB BANDWIDTH	9 kHz
--------------	----------	----------------------	-------

No	Freq. [MHz]	Corr. Factor (dB)	Reading Value		Emission Level		Limit		Margin	
			[dB (uV)]		[dB (uV)]		[dB (uV)]		(dB)	
			Q.P.	AV.	Q.P.	AV.	Q.P.	AV.	Q.P.	AV.
1	0.16172	0.06	47.96	40.52	48.02	40.58	65.38	55.38	-17.36	-14.80
2	0.18906	0.06	44.83	25.98	44.89	26.04	64.08	54.08	-19.19	-28.04
3	0.91563	0.11	38.40	32.20	38.51	32.31	56.00	46.00	-17.49	-13.69
4	3.20703	0.24	43.39	38.29	43.63	38.53	56.00	46.00	-12.37	-7.47
5	3.66406	0.26	43.11	38.19	43.37	38.45	56.00	46.00	-12.63	-7.55
6	11.68750	0.44	48.45	39.18	48.89	39.62	60.00	50.00	-11.11	-10.38

REMARKS:

1. Q.P. and AV. are abbreviations of quasi-peak and average individually.
2. The emission levels of other frequencies were very low against the limit.
3. Margin value = Emission level - Limit value
4. Correction factor = Insertion loss + Cable loss
5. Emission Level = Correction Factor + Reading Value.

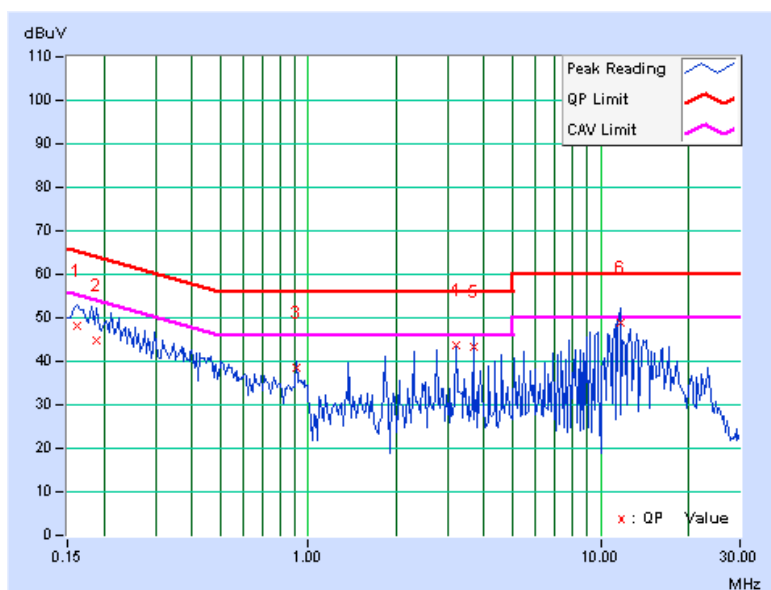



A D T

PHASE	Neutral (N)	6dB BANDWIDTH	9 kHz
--------------	-------------	----------------------	-------

No	Freq. [MHz]	Corr. Factor (dB)	Reading Value [dB (uV)]		Emission Level [dB (uV)]		Limit [dB (uV)]		Margin (dB)	
			Q.P.	AV.	Q.P.	AV.	Q.P.	AV.	Q.P.	AV.
			1	0.17344	0.07	46.52	27.83	46.59	27.90	64.79
2	0.23594	0.07	41.52	22.29	41.59	22.36	62.24	52.24	-20.65	-29.88
3	1.58594	0.16	24.70	13.25	24.86	13.41	56.00	46.00	-31.14	-32.59
4	3.20703	0.22	29.76	25.55	29.98	25.77	56.00	46.00	-26.02	-20.23
5	9.16016	0.36	32.44	28.19	32.80	28.55	60.00	50.00	-27.20	-21.45
6	12.59375	0.44	35.02	29.10	35.46	29.54	60.00	50.00	-24.54	-20.46

REMARKS:

6. Q.P. and AV. are abbreviations of quasi-peak and average individually.
7. The emission levels of other frequencies were very low against the limit.
8. Margin value = Emission level - Limit value
9. Correction factor = Insertion loss + Cable loss
10. Emission Level = Correction Factor + Reading Value.

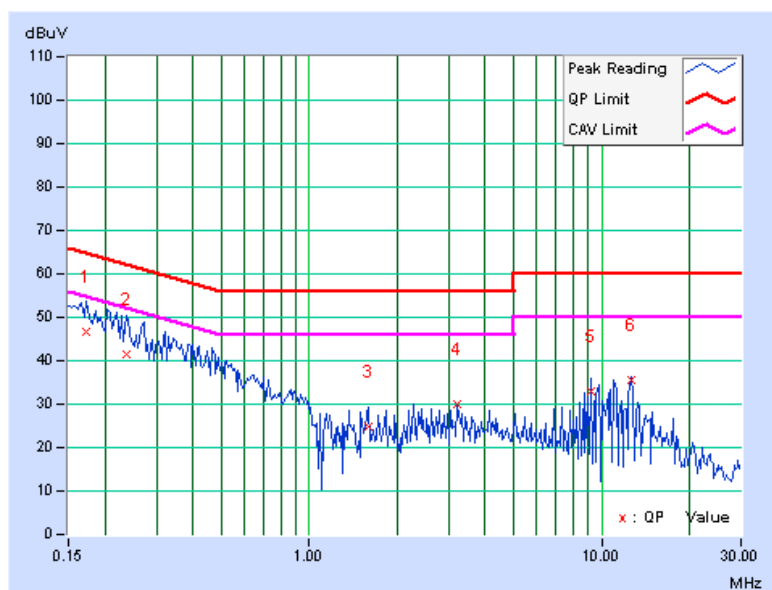

4.2 RADIATED EMISSION AND BANDEDGE MEASUREMENT

4.2.1 LIMITS OF RADIATED EMISSION AND BANDEDGE MEASUREMENT

Radiated emissions which fall in the restricted bands must comply with the radiated emission limits specified as below table. Other emissions shall be at least 20dB below the highest level of the desired power:

FREQUENCIES (MHz)	FIELD STRENGTH (microvolts/meter)	MEASUREMENT DISTANCE (meters)
0.009 ~ 0.490	2400/F(kHz)	300
0.490 ~ 1.705	24000/F(kHz)	30
1.705 ~ 30.0	30	30
30 ~ 88	100	3
88 ~ 216	150	3
216 ~ 960	200	3
Above 960	500	3

NOTE:

1. The lower limit shall apply at the transition frequencies.
2. Emission level (dBuV/m) = 20 log Emission level (uV/m).
3. For frequencies above 1000MHz, the field strength limits are based on average detector, however, the peak field strength of any emission shall not exceed the maximum permitted average limits, specified above by more than 20dB.



A D T

4.2.2 TEST INSTRUMENTS

For below 1GHz test

DESCRIPTION & MANUFACTURER	MODEL NO.	SERIAL NO.	CALIBRATED DATE	CALIBRATED UNTIL
Agilent Spectrum Analyzer	E4446A	MY48250254	July 12, 2011	July 11, 2012
Agilent Pre-Selector	N9039A	MY46520311	July 12, 2011	July 11, 2012
Agilent Signal Generator	N5181A	MY49060517	July 12, 2011	July 11, 2012
Mini-Circuits Pre-Amplifier	ZFL-1000VH2B	AMP-ZFL-03	Nov. 15, 2011	Nov. 14, 2012
Agilent Pre-Amplifier	8449B	3008A02578	July 04, 2011	July 03, 2012
SPACEK LABS	SLKKa-48-6	9K16	Nov. 15, 2011	Nov. 14, 2012
SCHWARZBECK Trilog Broadband Antenna	VULB 9168	9168-360	Apr. 09, 2012	Apr. 08, 2013
AISI Horn_Antenna	AIH.8018	0000320091110	Nov. 14, 2011	Nov. 13, 2012
SCHWARZBECK Horn_Antenna	BBHA 9170	9170-424	Oct. 07, 2011	Oct. 06, 2012
R&S Loop Antenna	HFH2-Z2	100070	Jan. 31, 2012	Jan. 30, 2014
RF CABLE	NA	RF104-201 RF104-203 RF104-204	Dec. 26, 2011	Dec. 25, 2012
RF Cable	NA	CHGCAB_001	Oct. 07, 2011	Oct. 06, 2012
Software	ADT_Radiated_V8.7.05	NA	NA	NA
CT Antenna Tower & Turn Table	NA	NA	NA	NA

Note:

1. The calibration interval of the above test instruments is 12 months and the calibrations are traceable to NML/ROC and NIST/USA.
2. * = The calibration interval of the above test instruments is 24 months and the calibrations are traceable to NML/ROC and NIST/USA.
3. The horn antenna, preamplifier (model: 8449B) are used only for the measurement of emission frequency above 1GHz if tested.
4. The test was performed in 966 Chamber No. G.
5. The FCC Site Registration No. is 966073.
6. The VCCI Site Registration No. is G-137.
7. The CANADA Site Registration No. is IC 7450H-2.
8. Tested Date: May 31, 2012

**A D T****For below 1GHz test**

DESCRIPTION & MANUFACTURER	MODEL NO.	SERIAL NO.	CALIBRATED DATE	CALIBRATED UNTIL
Agilent Spectrum Analyzer	E4446A	MY48250253	Aug. 29, 2011	Aug. 28, 2012
Agilent Pre-Selector	N9039A	MY46520310	Aug. 29, 2011	Aug. 28, 2012
Agilent Signal Generator	N5181A	MY49060347	July 25, 2011	July 24, 2012
Mini-Circuits Pre-Amplifier	ZFL-1000VH2B	AMP-ZFL-04	Nov. 15, 2011	Nov. 14, 2012
Agilent Pre-Amplifier	8449B	3008A02465	Feb. 27, 2012	Feb. 26, 2013
SPACEK LABS	SLKKa-48-6	9K16	Nov. 15, 2011	Nov. 14, 2012
SCHWARZBECK Trilog Broadband Antenna	VULB 9168	9168-361	Apr. 06, 2012	Apr. 05, 2013
AISI Horn_Antenna	AIH.8018	0000220091110	Nov. 23, 2011	Nov. 22, 2012
SCHWARZBECK Horn_Antenna	BBHA 9170	9170-424	Oct. 07, 2011	Oct. 06, 2012
*R&S Loop Antenna	HFH2-Z2	100070	Jan. 31, 2012	Jan. 30, 2014
RF CABLE	NA	RF104-205 RF104-207 RF104-202	Dec. 27, 2011	Dec. 26, 2012
RF Cable	NA	CHHCAB_001	Oct. 08, 2011	Oct. 07, 2012
Software	ADT_Radiated_V8.7.05	NA	NA	NA
CT Antenna Tower & Turn Table	NA	NA	NA	NA

Note:

1. The calibration interval of the above test instruments is 12 months and the calibrations are traceable to NML/ROC and NIST/USA.
2. * = The calibration interval of the above test instruments is 24 months and the calibrations are traceable to NML/ROC and NIST/USA.
- 3 The horn antenna, preamplifier (model: 8449B) are used only for the measurement of emission frequency above 1GHz if tested.
4. The test was performed in 966 Chamber No. H.
- 5 The FCC Site Registration No. is 797305.
- 6 The CANADA Site Registration No. is IC 7450H-3.
- 7 Tested Date: June 01, 2012

4.2.3 TEST PROCEDURES

- a. The EUT was placed on the top of a rotating table 0.8 meters above the ground at a 3 meters chamber room. The table was rotated 360 degrees to determine the position of the highest radiation.
- b. The EUT was set 3 meters away from the interference-receiving antenna, which was mounted on the top of a variable-height antenna tower.
- c. The height of antenna is varied from one meter to four meters above the ground to determine the maximum value of the field strength. Both horizontal and vertical polarizations of the antenna are set to make the measurement.
- d. For each suspected emission, the EUT was arranged to its worst case and then the antenna was tuned to heights from 1 meter to 4 meters and the rotatable table was turned from 0 degrees to 360 degrees to find the maximum reading.
- e. The test-receiver system was set to quasi-peak detect function and specified bandwidth with maximum hold mode when the test frequency is below 1 GHz.
- f. The test-receiver system was set to peak detect function and specified bandwidth with maximum hold mode when the test frequency is above 1 GHz.

NOTE:

1. The resolution bandwidth and video bandwidth of test receiver/spectrum analyzer is 120kHz for Quasi-peak detection (QP) at frequency below 1GHz.
2. The resolution bandwidth of test receiver/spectrum analyzer is 1 MHz and video bandwidth is 1MHz for Peak detection at frequency above 1GHz.

4.2.4 DEVIATION FROM TEST STANDARD

No deviation

4.2.5 TEST SETUP

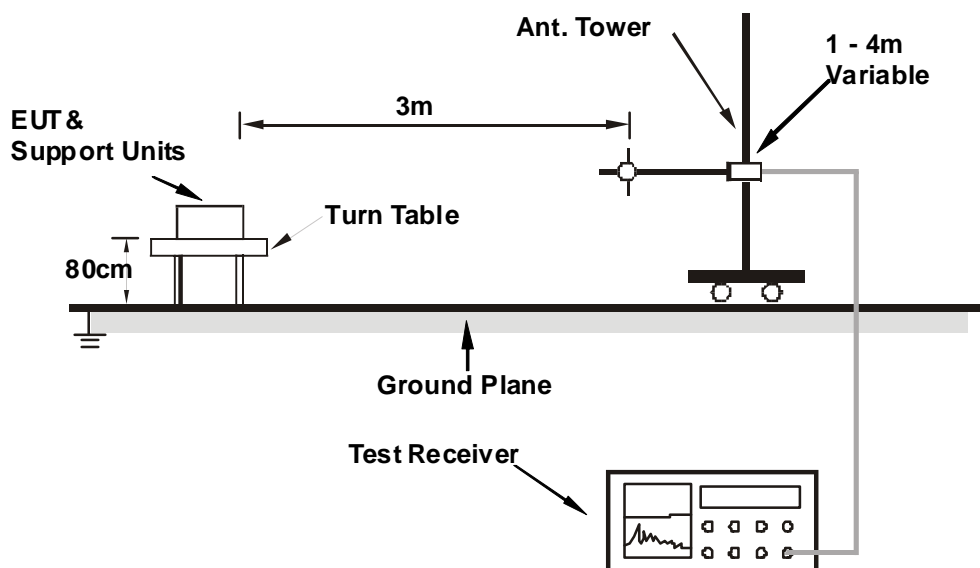

For the actual test configuration, please refer to the attached file (Test Setup Photo).

4.2.6 EUT OPERATING CONDITIONS

1. Turn on the power of all equipment.
2. EUT runs test program "InstallBlueSuite2 4 8.exe" to play music continuously.

4.2.7 TEST RESULTS

BELOW 1GHz WORST-CASE DATA

BT_GFSK

CHANNEL	TX Channel 39	DETECTOR FUNCTION	Quasi-Peak (QP)
FREQUENCY RANGE	Below 1GHz		

ANTENNA POLARITY & TEST DISTANCE: HORIZONTAL AT 3 M								
NO.	FREQ. (MHz)	EMISSION LEVEL (dBuV/m)	LIMIT (dBuV/m)	MARGIN (dB)	ANTENNA HEIGHT (m)	TABLE ANGLE (Degree)	RAW VALUE (dBuV)	CORRECTION FACTOR (dB/m)
1	192.00	34.4 QP	43.5	-9.1	1.00 H	90	22.55	11.88
2	216.28	38.6 QP	46.0	-7.4	1.50 H	228	26.75	11.87
3	241.38	39.4 QP	46.0	-6.6	1.00 H	298	26.44	12.97
4	304.50	37.3 QP	46.0	-8.7	1.00 H	148	21.90	15.41
5	478.59	33.9 QP	46.0	-12.1	1.50 H	244	14.05	19.85
6	605.18	34.1 QP	46.0	-11.9	1.50 H	256	11.38	22.73
ANTENNA POLARITY & TEST DISTANCE: VERTICAL AT 3 M								
NO.	FREQ. (MHz)	EMISSION LEVEL (dBuV/m)	LIMIT (dBuV/m)	MARGIN (dB)	ANTENNA HEIGHT (m)	TABLE ANGLE (Degree)	RAW VALUE (dBuV)	CORRECTION FACTOR (dB/m)
1	86.49	32.5 QP	40.0	-7.5	1.00 V	360	23.54	8.99
2	304.50	37.6 QP	46.0	-8.4	1.50 V	347	22.19	15.41
3	475.15	35.0 QP	46.0	-11.0	1.00 V	266	15.24	19.77
4	521.81	34.6 QP	46.0	-11.4	1.00 V	205	13.67	20.90
5	565.27	35.2 QP	46.0	-10.8	1.50 V	222	13.30	21.90
6	604.94	39.6 QP	46.0	-6.5	1.50 V	222	16.83	22.72

REMARKS:

1. Emission level (dBuV/m) = Raw Value (dBuV) + Correction Factor (dB/m).
2. Correction Factor (dB/m) = Antenna Factor (dB/m) + Cable Factor (dB).
3. The other emission levels were very low against the limit.
4. Margin value = Emission level – Limit value.

ABOVE 1GHz DATA

BT_GFSK

CHANNEL	TX Channel 0	DETECTOR FUNCTION	Peak (PK)
FREQUENCY RANGE	1GHz ~ 25GHz		

ANTENNA POLARITY & TEST DISTANCE: HORIZONTAL AT 3 M								
NO.	FREQ. (MHz)	EMISSION LEVEL (dBuV/m)	LIMIT (dBuV/m)	MARGIN (dB)	ANTENNA HEIGHT (m)	TABLE ANGLE (Degree)	RAW VALUE (dBuV)	CORRECTION FACTOR (dB/m)
1	2386.00	56.8 PK	74.0	-17.2	1.13 H	86	25.16	31.64
2	2386.00	26.3 AV	54.0	-27.7	1.13 H	86	-5.34	31.64
3	*2402.00	103.7 PK			1.13 H	86	72.00	31.70
4	*2402.00	73.2 AV			1.13 H	86	41.50	31.70
5	4804.00	67.5 PK	74.0	-6.5	1.00 H	231	28.60	38.90
6	4804.00	37.0 AV	54.0	-17.0	1.00 H	231	-1.90	38.90
ANTENNA POLARITY & TEST DISTANCE: VERTICAL AT 3 M								
NO.	FREQ. (MHz)	EMISSION LEVEL (dBuV/m)	LIMIT (dBuV/m)	MARGIN (dB)	ANTENNA HEIGHT (m)	TABLE ANGLE (Degree)	RAW VALUE (dBuV)	CORRECTION FACTOR (dB/m)
1	1601.70	47.2 PK	74.0	-26.8	1.00 V	267	18.85	28.35
2	1601.70	16.7 AV	54.0	-37.3	1.00 V	267	-11.65	28.35
3	2386.00	57.1 PK	74.0	-16.9	1.17 V	320	25.46	31.64
4	2386.00	26.6 AV	54.0	-27.4	1.17 V	320	-5.04	31.64
5	*2402.00	104.2 PK			1.19 V	316	72.50	31.70
6	*2402.00	73.7 AV			1.19 V	316	42.00	31.70
7	4804.00	68.8 PK	74.0	-5.2	1.00 V	117	29.90	38.90
8	4804.00	38.3 AV	54.0	-15.7	1.00 V	117	-0.60	38.90

REMARKS:

1. Emission level (dBuV/m) = Raw Value (dBuV) + Correction Factor (dB/m).
2. Correction Factor (dB/m) = Antenna Factor (dB/m) + Cable Factor (dB).
3. The other emission levels were very low against the limit.
4. Margin value = Emission level – Limit value.
5. " * ": Fundamental frequency.
6. The DH5 packet was the worse case duty cycle for a transmit dwell time on a channel, based upon bluetooth theory the transmitter is on $0.625 * 5$ per 296.25 ms per channel. Therefore, the duty cycle correlation factor be equal to: $20\log(3.125 / 100) = -30.1$ dB.
7. Average value = peak reading + $20\log(\text{duty cycle})$.



A D T

CHANNEL	TX Channel 39	DETECTOR FUNCTION	Peak (PK)
FREQUENCY RANGE	1GHz ~ 25GHz		

ANTENNA POLARITY & TEST DISTANCE: HORIZONTAL AT 3 M

NO.	FREQ. (MHz)	EMISSION LEVEL (dBuV/m)	LIMIT (dBuV/m)	MARGIN (dB)	ANTENNA HEIGHT (m)	TABLE ANGLE (Degree)	RAW VALUE (dBuV)	CORRECTION FACTOR (dB/m)
1	*2441.00	103.9 PK			1.16 H	89	72.07	31.83
2	*2441.00	73.4 AV			1.16 H	89	41.57	31.83
3	4882.00	67.8 PK	74.0	-6.2	1.01 H	245	28.63	39.17
4	4882.00	37.3 AV	54.0	-16.7	1.01 H	245	-1.87	39.17
5	7323.00	55.6 PK	74.0	-18.4	1.16 H	221	8.97	46.63
6	7323.00	25.1 AV	54.0	-28.9	1.16 H	221	-21.53	46.63

ANTENNA POLARITY & TEST DISTANCE: VERTICAL AT 3 M

NO.	FREQ. (MHz)	EMISSION LEVEL (dBuV/m)	LIMIT (dBuV/m)	MARGIN (dB)	ANTENNA HEIGHT (m)	TABLE ANGLE (Degree)	RAW VALUE (dBuV)	CORRECTION FACTOR (dB/m)
1	#1626.70	47.2 PK	84.2	-37.0	1.00 V	267	18.73	28.47
2	#1626.70	16.7 AV	53.7	-37.0	1.00 V	267	-11.77	28.47
3	*2441.00	104.2 PK			1.15 V	320	72.37	31.83
4	*2441.00	73.7 AV			1.15 V	320	41.87	31.83
5	4882.00	69.6 PK	74.0	-4.4	1.00 V	117	30.43	39.17
6	4882.00	39.1 AV	54.0	-14.9	1.00 V	117	-0.07	39.17
7	7323.00	55.5 PK	74.0	-18.5	1.20 V	165	8.87	46.63
8	7323.00	25 AV	54.0	-29.0	1.20 V	165	-21.63	46.63

REMARKS:

1. Emission level (dBuV/m) = Raw Value (dBuV) + Correction Factor (dB/m).
2. Correction Factor (dB/m) = Antenna Factor (dB/m) + Cable Factor (dB).
3. The other emission levels were very low against the limit.
4. Margin value = Emission level – Limit value.
5. " * ": Fundamental frequency.
6. " # ": The radiated frequency is out of the restricted band.
7. The DH5 packet was the worse case duty cycle for a transmit dwell time on a channel, based upon bluetooth theory the transmitter is on 0.625 * 5 per 296.25 ms per channel. Therefore, the duty cycle correlation factor be equal to: $20\log(3.125 / 100) = -30.1 \text{ dB}$.
8. Average value = peak reading + $20\log(\text{duty cycle})$.



A D T

CHANNEL	TX Channel 78	DETECTOR FUNCTION	Peak (PK)
FREQUENCY RANGE	1GHz ~ 25GHz		

ANTENNA POLARITY & TEST DISTANCE: HORIZONTAL AT 3 M

NO.	FREQ. (MHz)	EMISSION LEVEL (dBuV/m)	LIMIT (dBuV/m)	MARGIN (dB)	ANTENNA HEIGHT (m)	TABLE ANGLE (Degree)	RAW VALUE (dBuV)	CORRECTION FACTOR (dB/m)
1	*2480.00	103.8 PK			1.13 H	90	71.85	31.95
2	*2480.00	73.3 AV			1.13 H	90	41.35	31.95
3	2483.50	55.3 PK	74.0	-18.7	1.13 H	90	23.33	31.97
4	2483.50	24.8 AV	54.0	-29.2	1.13 H	90	-7.17	31.97
5	4960.00	65.5 PK	74.0	-8.5	1.02 H	22	26.08	39.42
6	4960.00	35.0 AV	54.0	-19.0	1.02 H	22	-4.42	39.42
7	7440.00	53.7 PK	74.0	-20.3	1.15 H	215	7.14	46.56
8	7440.00	23.2 AV	54.0	-30.8	1.15 H	215	-23.36	46.56

ANTENNA POLARITY & TEST DISTANCE: VERTICAL AT 3 M

NO.	FREQ. (MHz)	EMISSION LEVEL (dBuV/m)	LIMIT (dBuV/m)	MARGIN (dB)	ANTENNA HEIGHT (m)	TABLE ANGLE (Degree)	RAW VALUE (dBuV)	CORRECTION FACTOR (dB/m)
1	#1652.70	46.5 PK	84.0	-37.5	1.00 V	347	17.90	28.60
2	#1652.70	16.0 AV	53.5	-37.5	1.00 V	347	-12.60	28.60
3	*2480.00	104.0 PK			1.13 V	321	72.05	31.95
4	*2480.00	73.5 AV			1.13 V	321	41.55	31.95
5	2483.50	56.9 PK	74.0	-17.1	1.13 V	321	24.93	31.97
6	2483.50	26.4 AV	54.0	-27.6	1.13 V	321	-5.57	31.97
7	4960.00	66.8 PK	74.0	-7.2	1.00 V	117	27.38	39.42
8	4960.00	36.3 AV	54.0	-17.7	1.00 V	117	-3.12	39.42
9	7440.00	55.2 PK	74.0	-18.8	1.18 V	152	8.64	46.56
10	7440.00	24.7 AV	54.0	-29.3	1.18 V	152	-21.86	46.56

REMARKS:

1. Emission level (dBuV/m) = Raw Value (dBuV) + Correction Factor (dB/m).
2. Correction Factor (dB/m) = Antenna Factor (dB/m) + Cable Factor (dB).
3. The other emission levels were very low against the limit.
4. Margin value = Emission level – Limit value.
5. " * ": Fundamental frequency.
6. " # ": The radiated frequency is out of the restricted band.
7. The DH5 packet was the worse case duty cycle for a transmit dwell time on a channel, based upon bluetooth theory the transmitter is on 0.625 * 5 per 296.25 ms per channel. Therefore, the duty cycle correlation factor be equal to: $20\log(3.125 / 100) = -30.1$ dB.
8. Average value = peak reading + $20\log(\text{duty cycle})$.



A D T

BT_8DPSK

CHANNEL	TX Channel 0	DETECTOR FUNCTION	Peak (PK)
FREQUENCY RANGE	1GHz ~ 25GHz		

ANTENNA POLARITY & TEST DISTANCE: HORIZONTAL AT 3 M								
NO.	FREQ. (MHz)	EMISSION LEVEL (dBuV/m)	LIMIT (dBuV/m)	MARGIN (dB)	ANTENNA HEIGHT (m)	TABLE ANGLE (Degree)	RAW VALUE (dBuV)	CORRECTION FACTOR (dB/m)
1	2390.00	56.4 PK	74.0	-17.6	1.17 H	86	24.74	31.66
2	2390.00	25.9 AV	54.0	-28.1	1.17 H	86	-5.76	31.66
3	*2402.00	101.7 PK			1.17 H	86	70.00	31.70
4	*2402.00	71.2 AV			1.17 H	86	39.50	31.70
5	4804.00	61.3 PK	74.0	-12.7	1.05 H	22	22.40	38.90
6	4804.00	30.8 AV	54.0	-23.2	1.05 H	22	-8.10	38.90
ANTENNA POLARITY & TEST DISTANCE: VERTICAL AT 3 M								
NO.	FREQ. (MHz)	EMISSION LEVEL (dBuV/m)	LIMIT (dBuV/m)	MARGIN (dB)	ANTENNA HEIGHT (m)	TABLE ANGLE (Degree)	RAW VALUE (dBuV)	CORRECTION FACTOR (dB/m)
1	1601.70	47.5 PK	74.0	-26.5	1.03 V	279	19.15	28.35
2	1601.70	17 AV	54.0	-37.0	1.03 V	279	-11.35	28.35
3	2390.00	56.9 PK	74.0	-17.1	1.20 V	321	25.24	31.66
4	2390.00	26.4 AV	54.0	-27.6	1.20 V	321	-5.26	31.66
5	*2402.00	102.2 PK			1.19 V	319	70.50	31.70
6	*2402.00	71.7 AV			1.19 V	319	40	31.70
7	4804.00	62.2 PK	74.0	-11.8	1.00 V	117	23.30	38.90
8	4804.00	31.7 AV	54.0	-22.3	1.00 V	117	-7.20	38.90

REMARKS:

1. Emission level (dBuV/m) = Raw Value (dBuV) + Correction Factor (dB/m).
2. Correction Factor (dB/m) = Antenna Factor (dB/m) + Cable Factor (dB).
3. The other emission levels were very low against the limit.
4. Margin value = Emission level – Limit value.
5. " * ": Fundamental frequency.
6. The DH5 packet was the worse case duty cycle for a transmit dwell time on a channel, based upon bluetooth theory the transmitter is on $0.625 * 5$ per 296.25 ms per channel. Therefore, the duty cycle correlation factor be equal to: $20\log(3.125 / 100) = -30.1$ dB.
7. Average value = peak reading + $20\log(\text{duty cycle})$.



A D T

CHANNEL	TX Channel 39	DETECTOR FUNCTION	Peak (PK)
FREQUENCY RANGE	1GHz ~ 25GHz		

ANTENNA POLARITY & TEST DISTANCE: HORIZONTAL AT 3 M								
NO.	FREQ. (MHz)	EMISSION LEVEL (dBuV/m)	LIMIT (dBuV/m)	MARGIN (dB)	ANTENNA HEIGHT (m)	TABLE ANGLE (Degree)	RAW VALUE (dBuV)	CORRECTION FACTOR (dB/m)
1	*2441.00	101.6 PK			1.16 H	75	69.77	31.83
2	*2441.00	71.1 AV			1.16 H	75	39.27	31.83
3	4882.00	60.9 PK	74.0	-13.1	1.06 H	19	21.73	39.17
4	4882.00	30.4 AV	54.0	-23.6	1.06 H	19	-8.77	39.17
5	7323.00	53.5 PK	74.0	-20.5	1.11 H	228	6.87	46.63
6	7323.00	23.0 AV	54.0	-31.0	1.11 H	228	-23.63	46.63

ANTENNA POLARITY & TEST DISTANCE: VERTICAL AT 3 M								
NO.	FREQ. (MHz)	EMISSION LEVEL (dBuV/m)	LIMIT (dBuV/m)	MARGIN (dB)	ANTENNA HEIGHT (m)	TABLE ANGLE (Degree)	RAW VALUE (dBuV)	CORRECTION FACTOR (dB/m)
1	#1626.70	47.0 PK	82.1	-27	1.02 V	265	18.53	28.47
2	#1626.70	16.5 AV	51.6	-37.15	1.02 V	265	-11.97	28.47
3	*2441.00	102.1 PK			1.20 V	320	70.27	31.83
4	*2441.00	71.6 AV			1.20 V	320	39.77	31.83
5	4882.00	61.2 PK	74.0	-12.8	1.00 V	118	22.03	39.17
6	4882.00	30.7 AV	54.0	-23.3	1.00 V	118	-8.47	39.17
7	7323.00	54.3 PK	74.0	-19.7	1.07 V	190	7.67	46.63
8	7323.00	23.8 AV	54.0	-30.2	1.07 V	190	-22.83	46.63

REMARKS:

1. Emission level (dBuV/m) = Raw Value (dBuV) + Correction Factor (dB/m).
2. Correction Factor (dB/m) = Antenna Factor (dB/m) + Cable Factor (dB).
3. The other emission levels were very low against the limit.
4. Margin value = Emission level – Limit value.
5. " * ": Fundamental frequency.
6. " # ": The radiated frequency is out of the restricted band.
7. The DH5 packet was the worse case duty cycle for a transmit dwell time on a channel, based upon bluetooth theory the transmitter is on 0.625 * 5 per 296.25 ms per channel. Therefore, the duty cycle correlation factor be equal to: $20\log(3.125 / 100) = -30.1 \text{ dB}$.
8. Average value = peak reading + $20\log(\text{duty cycle})$.



A D T

CHANNEL	TX Channel 78	DETECTOR FUNCTION	Peak (PK)
FREQUENCY RANGE	1GHz ~ 25GHz		

ANTENNA POLARITY & TEST DISTANCE: HORIZONTAL AT 3 M

NO.	FREQ. (MHz)	EMISSION LEVEL (dBuV/m)	LIMIT (dBuV/m)	MARGIN (dB)	ANTENNA HEIGHT (m)	TABLE ANGLE (Degree)	RAW VALUE (dBuV)	CORRECTION FACTOR (dB/m)
1	*2480.00	100.8 PK			1.14 H	84	68.85	31.95
2	*2480.00	70.3 AV			1.14 H	84	38.35	31.95
3	2483.50	56.0 PK	74.0	-18.0	1.14 H	84	24.03	31.97
4	2483.50	25.5 AV	54.0	-28.5	1.14 H	84	-6.47	31.97
5	4960.00	65.1 PK	74.0	-8.9	1.05 H	7	25.68	39.42
6	4960.00	34.6 AV	54.0	-19.4	1.05 H	7	-4.82	39.42
7	7440.00	54.0 PK	74.0	-20.0	1.06 H	232	7.44	46.56
8	7440.00	23.5 AV	54.0	-30.5	1.06 H	232	-23.06	46.56

ANTENNA POLARITY & TEST DISTANCE: VERTICAL AT 3 M

NO.	FREQ. (MHz)	EMISSION LEVEL (dBuV/m)	LIMIT (dBuV/m)	MARGIN (dB)	ANTENNA HEIGHT (m)	TABLE ANGLE (Degree)	RAW VALUE (dBuV)	CORRECTION FACTOR (dB/m)
1	#1652.70	46.4 PK	81.0	-27.6	1.00 V	338	17.80	28.60
2	#1652.70	15.9 AV	50.5	-38.1	1.00 V	338	-12.7	28.60
3	*2480.00	101.0 PK			1.19 V	320	69.05	31.95
4	*2480.00	70.5 AV			1.19 V	320	38.55	31.95
5	2483.50	56.6 PK	74.0	-17.4	1.19 V	320	24.63	31.97
6	2483.50	26.1 AV	54.0	-27.9	1.19 V	320	-5.87	31.97
7	4960.00	65.8 PK	74.0	-8.2	1.00 V	102	26.38	39.42
8	4960.00	35.3 AV	54.0	-18.7	1.00 V	102	-4.12	39.42
9	7440.00	54.6 PK	74.0	-19.4	1.05 V	185	8.04	46.56
10	7440.00	24.1 AV	54.0	-29.9	1.05 V	185	-22.46	46.56

REMARKS:

1. Emission level (dBuV/m) = Raw Value (dBuV) + Correction Factor (dB/m).
2. Correction Factor (dB/m) = Antenna Factor (dB/m) + Cable Factor (dB).
3. The other emission levels were very low against the limit.
4. Margin value = Emission level – Limit value.
5. " * ": Fundamental frequency.
6. " # ": The radiated frequency is out of the restricted band.
7. The DH5 packet was the worse case duty cycle for a transmit dwell time on a channel, based upon bluetooth theory the transmitter is on 0.625 * 5 per 296.25 ms per channel. Therefore, the duty cycle correlation factor be equal to: $20\log(3.125 / 100) = -30.1$ dB.
8. Average value = peak reading + $20\log(\text{duty cycle})$.

4.3 NUMBER OF HOPPING FREQUENCY USED

4.3.1 LIMIT OF HOPPING FREQUENCY USED

At least 15 hopping frequencies, and should be equally spaced.

4.3.2 TEST INSTRUMENTS

DESCRIPTION & MANUFACTURER	MODEL NO.	SERIAL NO.	CALIBRATED DATE	CALIBRATED UNTIL
R&S Spectrum Analyzer	FSP 40	100036	Dec 14, 2011	Dec 13, 2012

NOTE: 1. The calibration interval of the above test instruments is 12 months and the calibrations are traceable to NML/ROC and NIST/USA.

2. Tested date: June 04, 2012

4.3.3 TEST PROCEDURES

- a. Check the calibration of the measuring instrument (SA) using either an internal calibrator or a known signal from an external generator.
- b. Turn on the EUT and connect its antenna terminal to measurement via a low loss cable. Then set it to any one measured frequency within its operating range and make sure the instrument is operated in its linear range.
- c. Set the SA on MaxHold Mode, and then keep the EUT in hopping mode. Record all the signals from each channel until each one has been recorded.
- d. Set the SA on View mode and then plot the result on SA screen.
- e. Repeat above procedures until all frequencies measured were complete.

4.3.4 DEVIATION FROM TEST STANDARD

No deviation

4.3.5 TEST SETUP

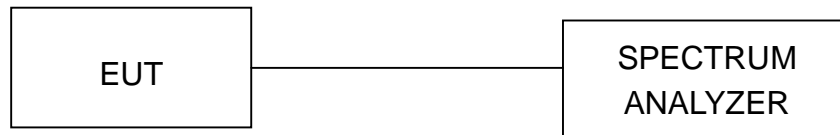

4.3.6 TEST RESULTS

There are 79 hopping frequencies in the hopping mode. Please refer to next pages for the test result. On the plots, it shows that the hopping frequencies are equally spaced.



A D T

For GFSK

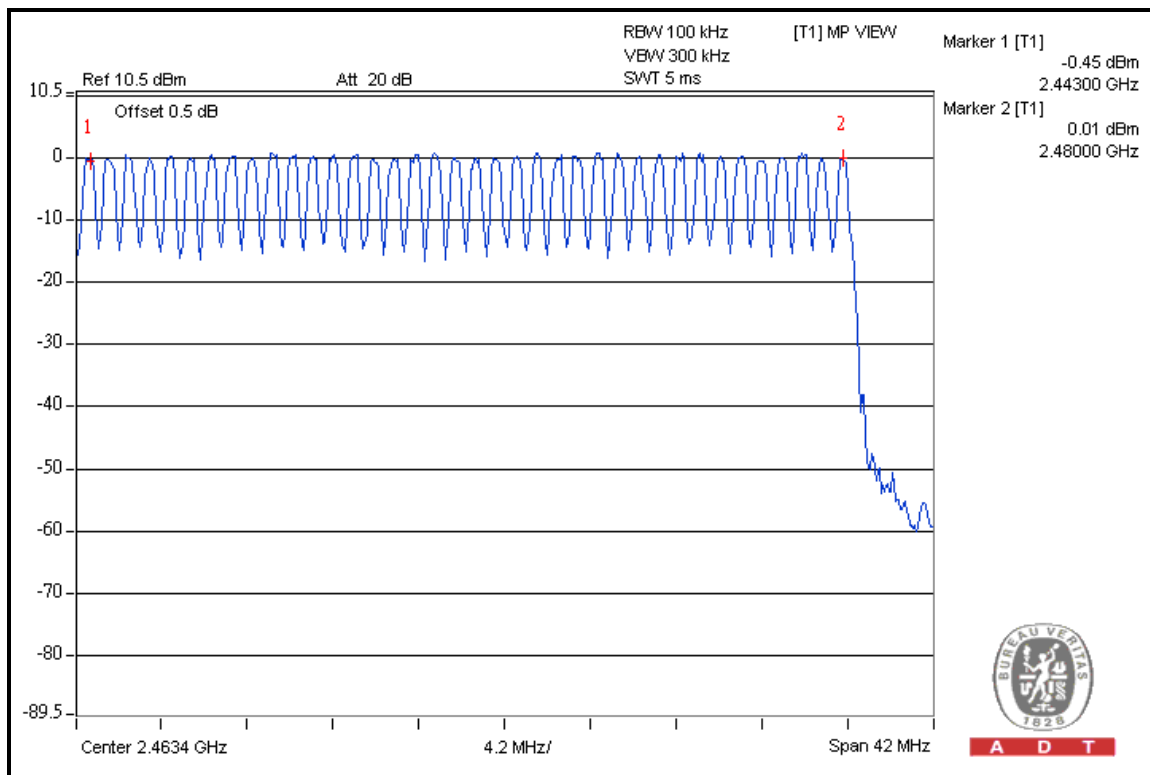
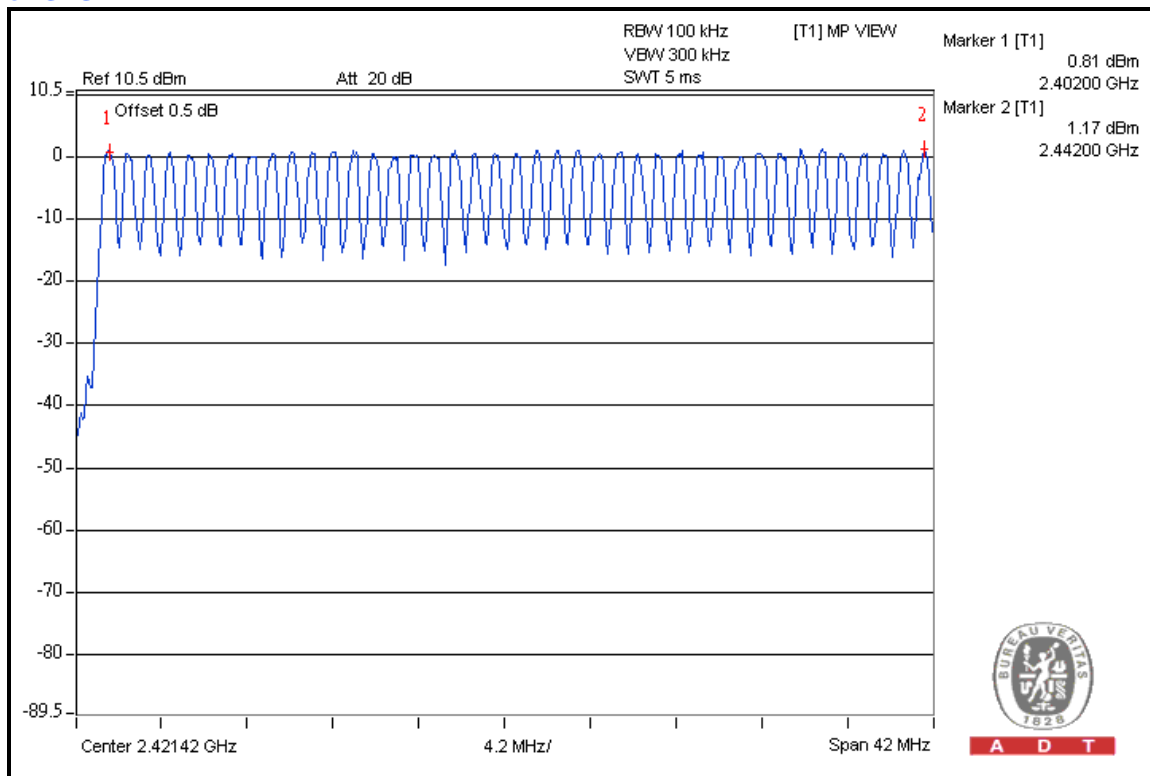



A D T

For 8DPSK

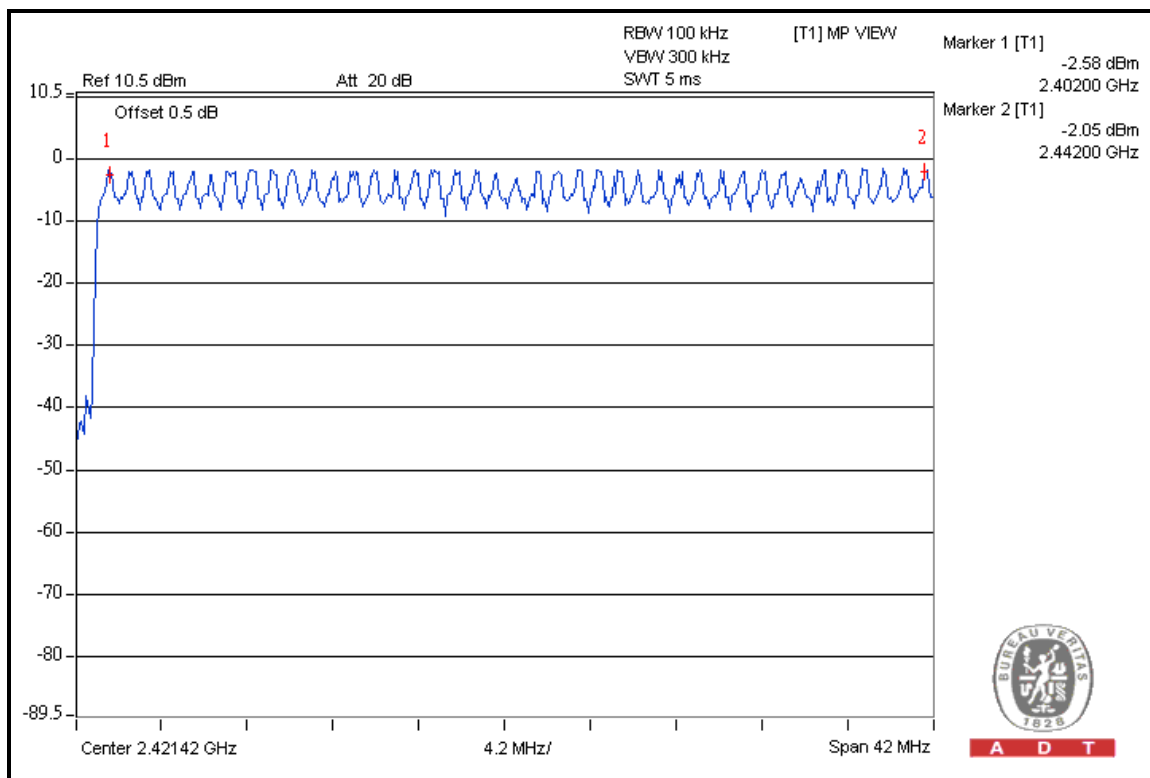

A D T

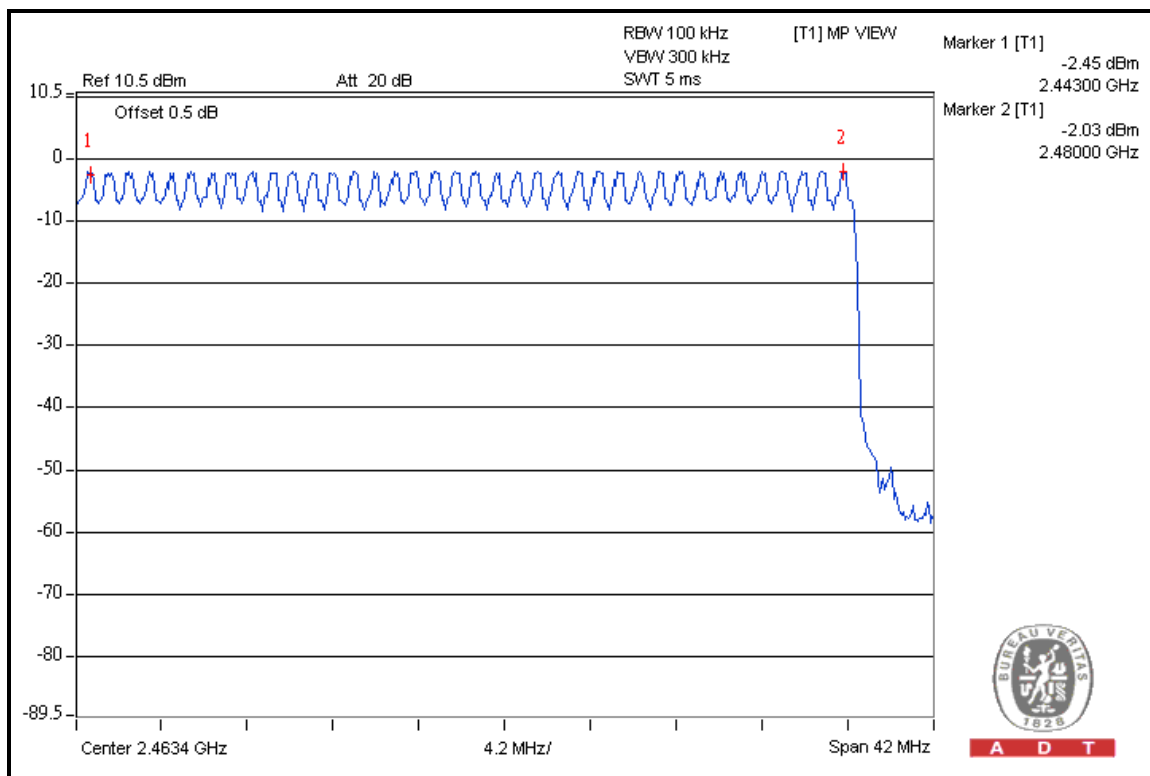

A D T

4.4 DWELL TIME ON EACH CHANNEL

4.4.1 LIMIT OF DWELL TIME USED

The average time of occupancy on any channel shall not be greater than 0.4 seconds within a period of 0.4 seconds multiplied by the number of hopping channels employed.

4.4.2 TEST INSTRUMENTS

DESCRIPTION & MANUFACTURER	MODEL NO.	SERIAL NO.	CALIBRATED DATE	CALIBRATED UNTIL
R&S Spectrum Analyzer	FSP 40	100036	Dec 14, 2011	Dec 13, 2012

NOTE: 1. The calibration interval of the above test instruments is 12 months and the calibrations are traceable to NML/ROC and NIST/USA.

2. Tested date: June 04, 2012

4.4.3 TEST PROCEDURES

- a. Check the calibration of the measuring instrument (SA) using either an internal calibrator or a known signal from an external generator.
- b. Turn on the EUT and connect its antenna terminal to measurement via a low loss cable. Then set it to any one measured frequency within its operating range and make sure the instrument is operated in its linear range.
- c. Adjust the center frequency of SA on any frequency be measured and set SA to zero span mode. And then, set RBW and VBW of spectrum analyzer to proper value.
- d. Measure the time duration of one transmission on the measured frequency. And then plot the result with time difference of this time duration.
- e. Repeat above procedures until all different time-slot modes have been completed.

4.4.4 DEVIATION FROM TEST STANDARD

No deviation

4.4.5 TEST SETUP

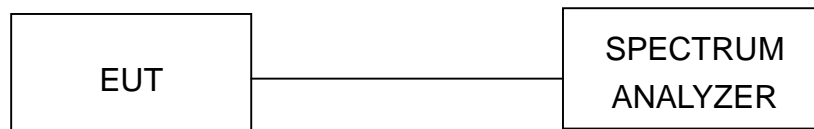

4.4.6 TEST RESULTS

For GFSK:

Mode	Number of transmission in a 31.6 (79Hopping*0.4)	Length of transmission time (msec)	Result (msec)	Limit (msec)
DH1	50 (times / 5 sec) *6.32=316 times	0.486	153.58	400
DH3	25 (times / 5 sec) *6.32=158 times	1.73	273.34	400
DH5	16 (times / 5 sec) *6.32=101.12 times	2.97	300.33	400

NOTE: Test plots of the transmitting time slot are shown on next page.



A D T

DH1

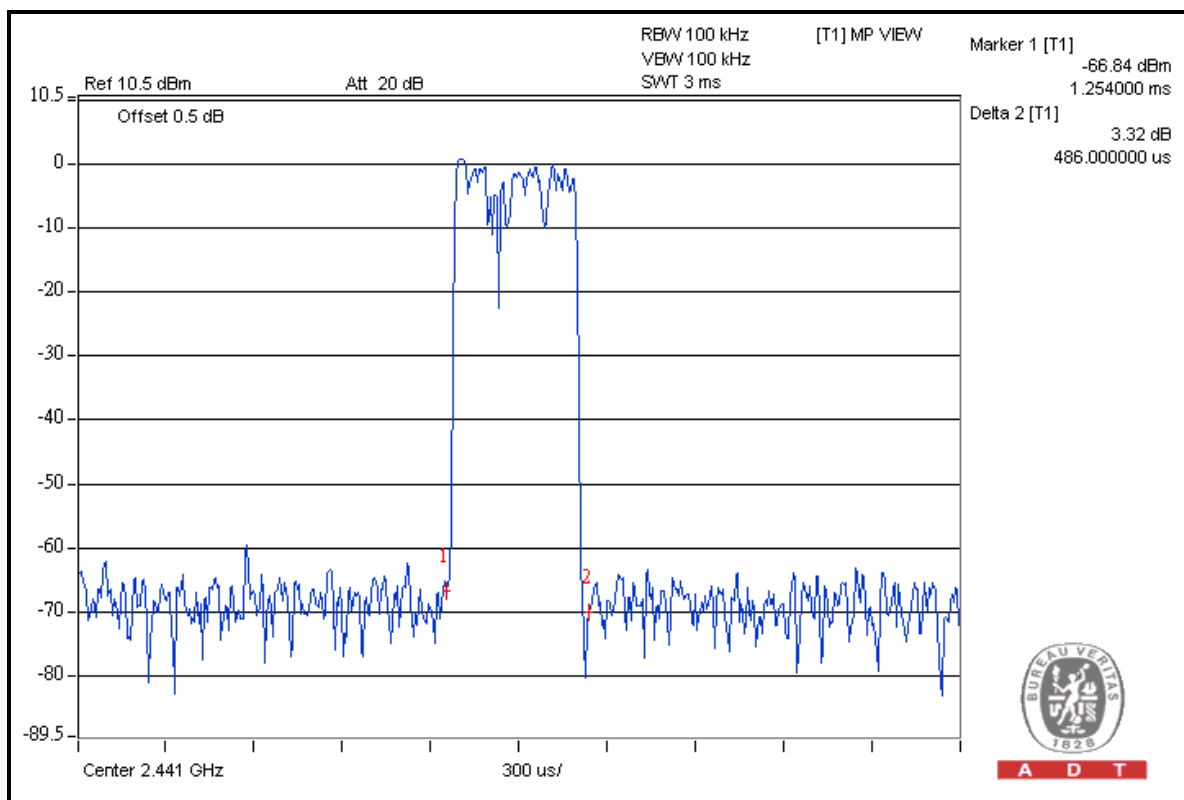
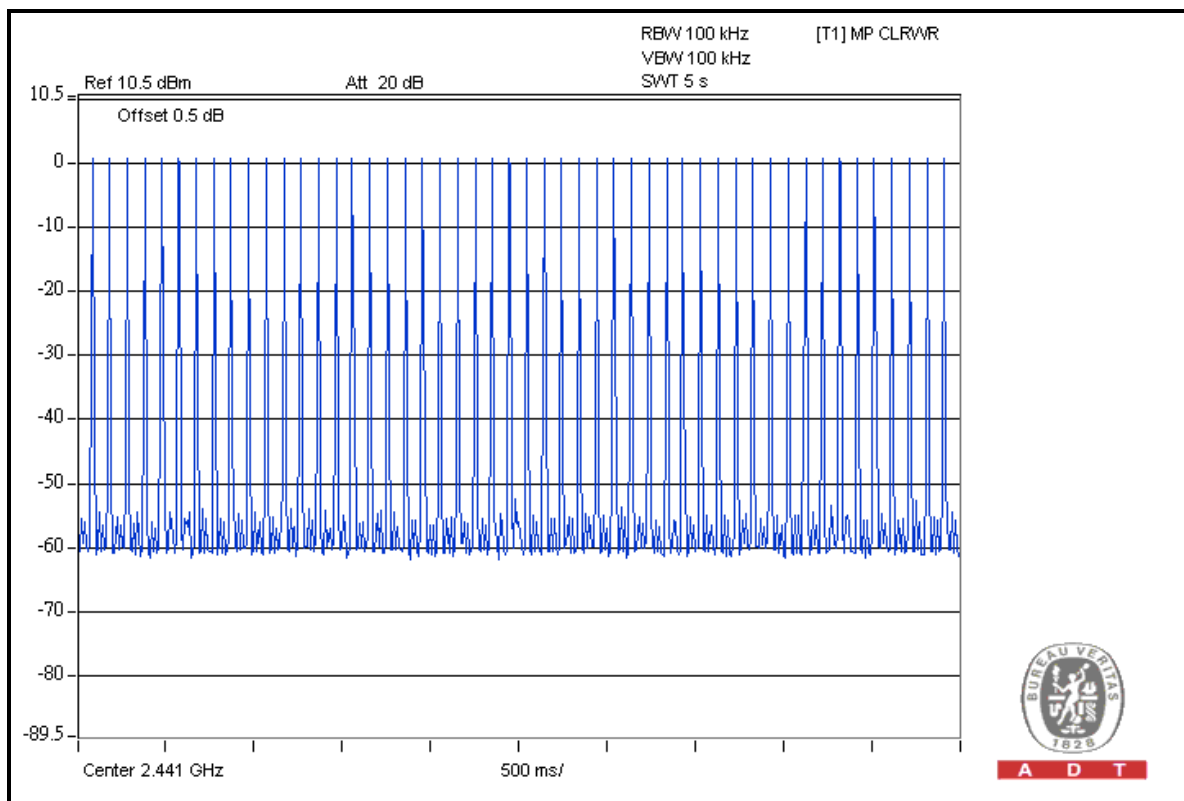



A D T

DH3

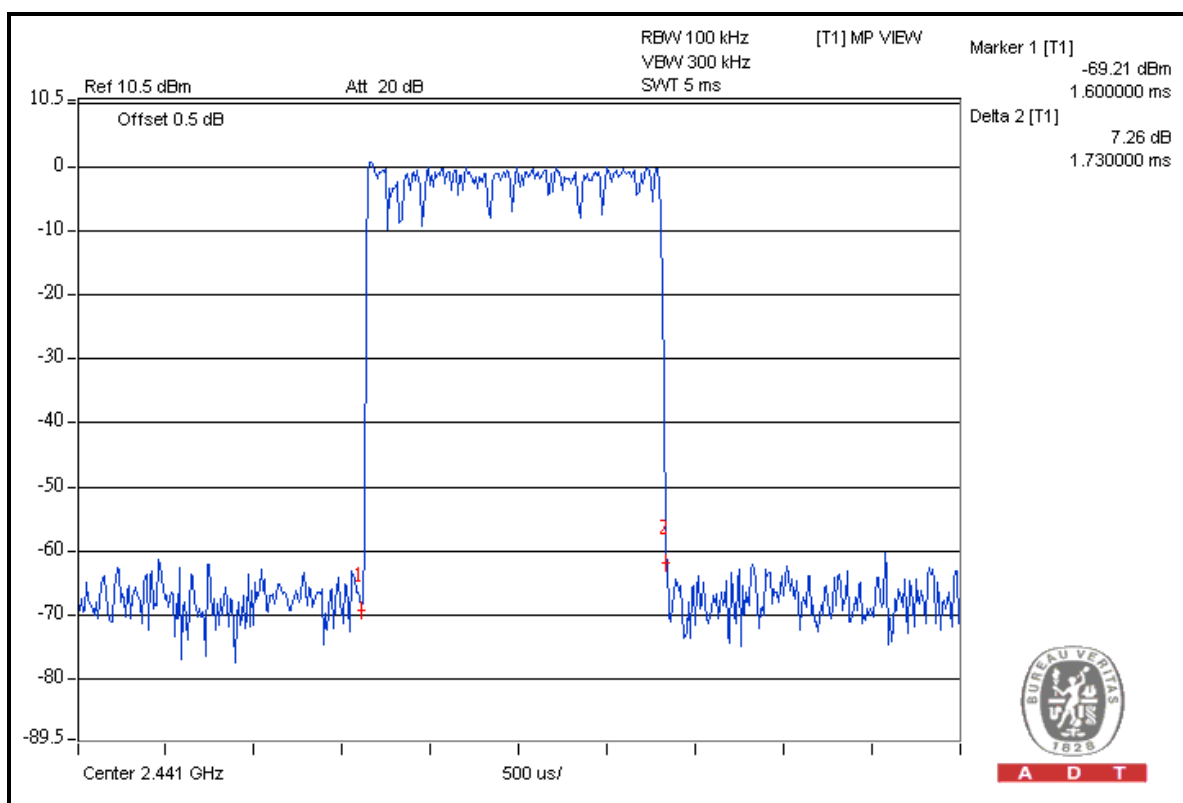
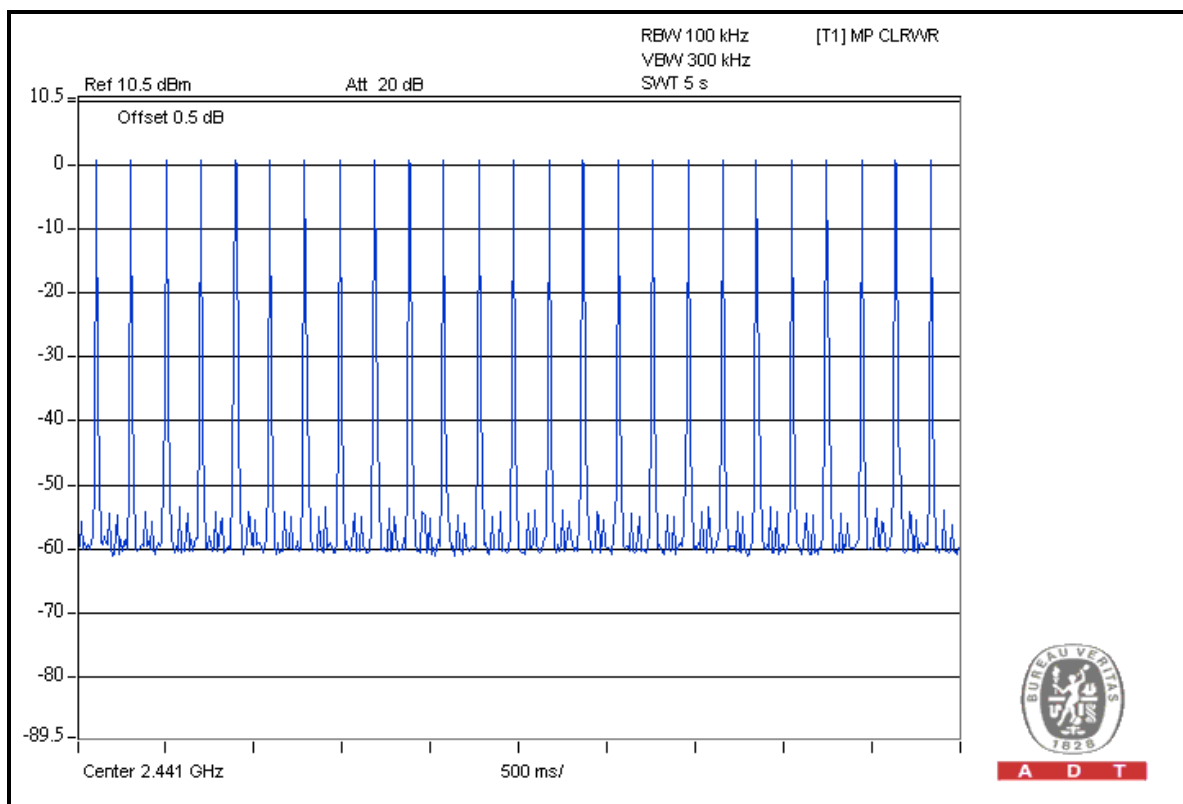



A D T

DH5

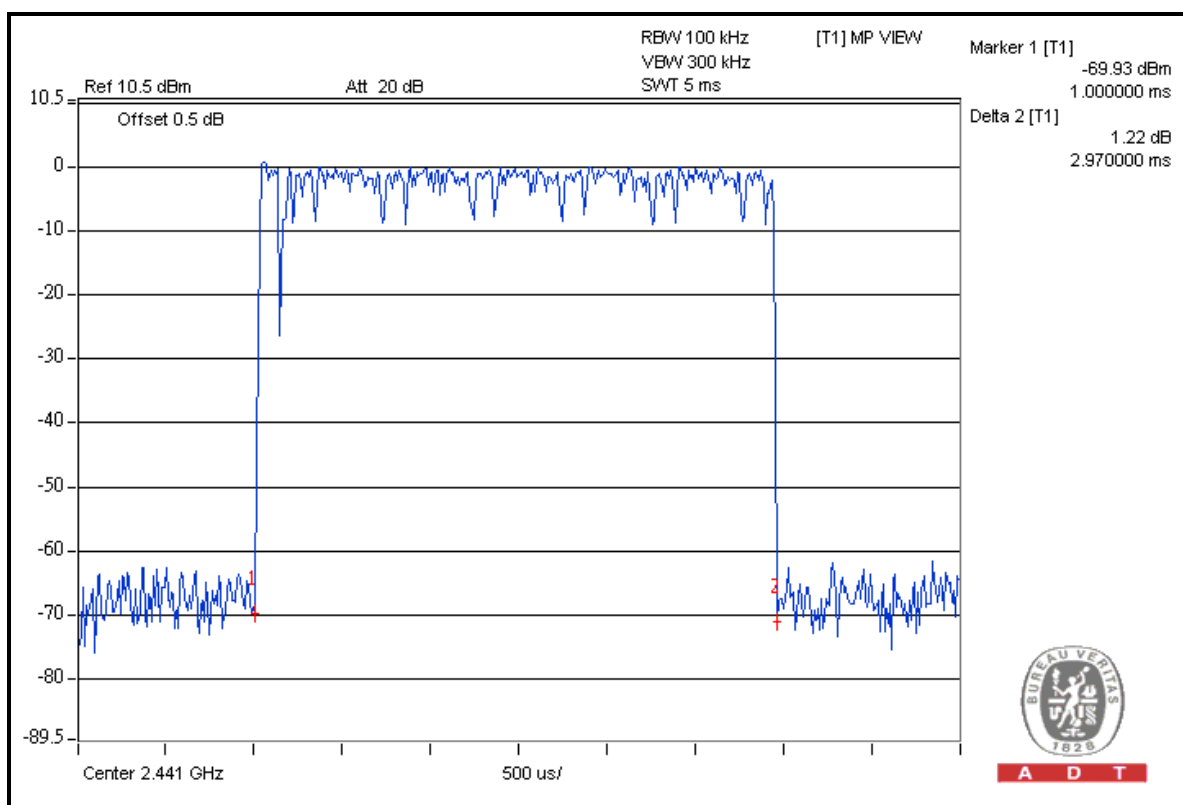
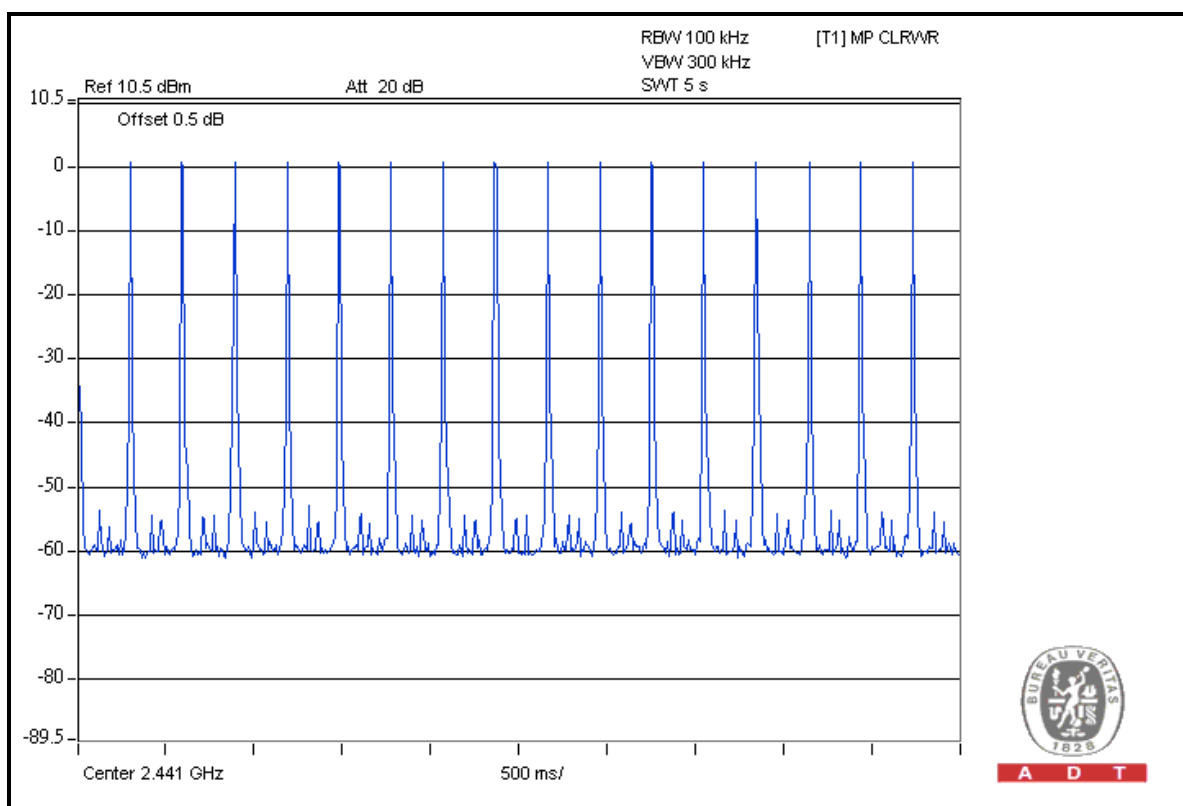



A D T

For 8DPSK:

Mode	Number of transmission in a 31.6 (79Hopping*0.4)	Length of transmission time (msec)	Result (msec)	Limit (msec)
DH1	50 (times / 5 sec) *6.32=316 times	0.498	157.37	400
DH3	25 (times / 5 sec) *6.32=158 times	1.76	278.08	400
DH5	17 (times / 5 sec) *6.32=107.44 times	3.05	327.69	400

NOTE: Test plots of the transmitting time slot are shown on next page.



A D T

DH1

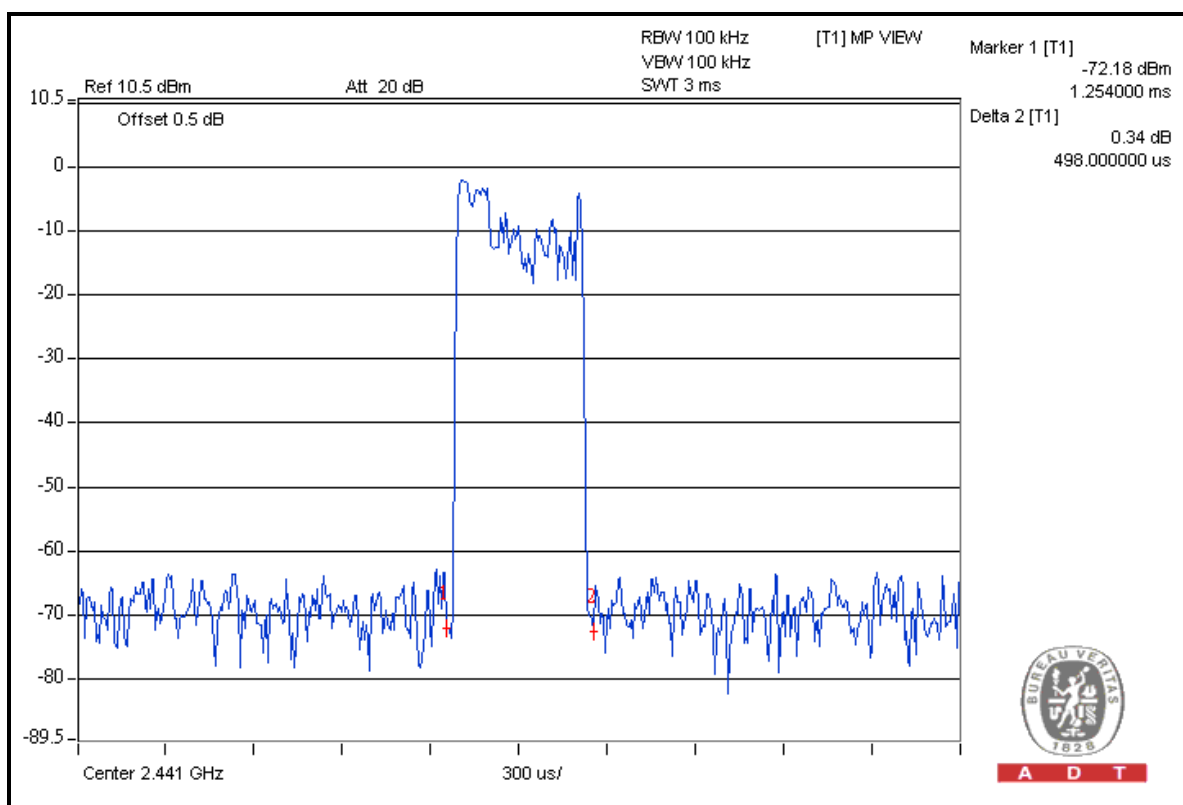
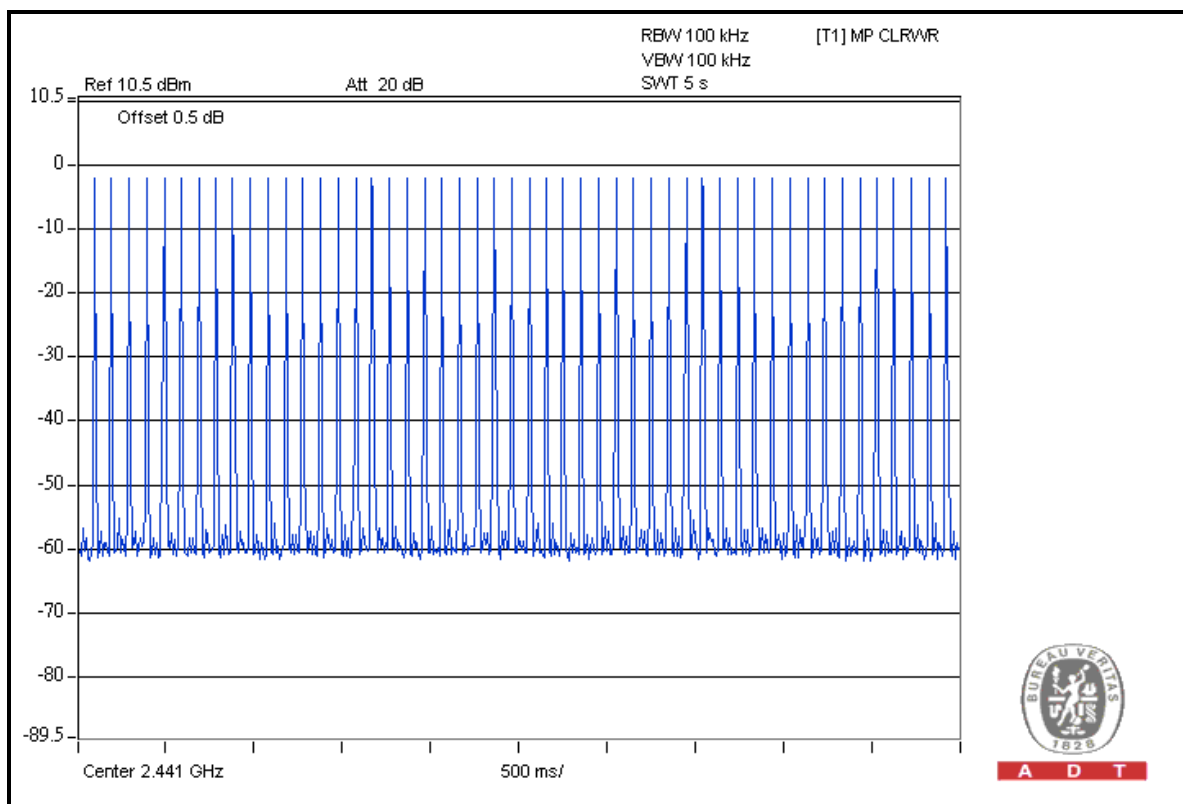



A D T

DH3

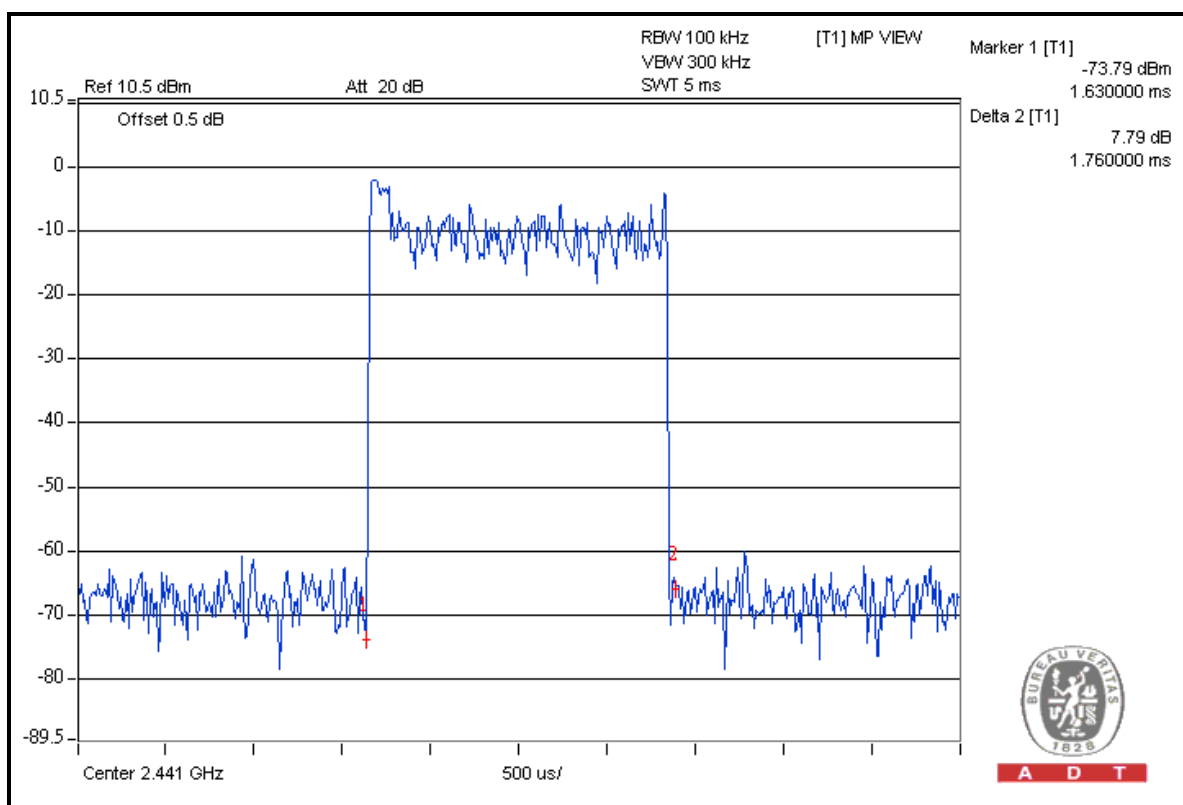
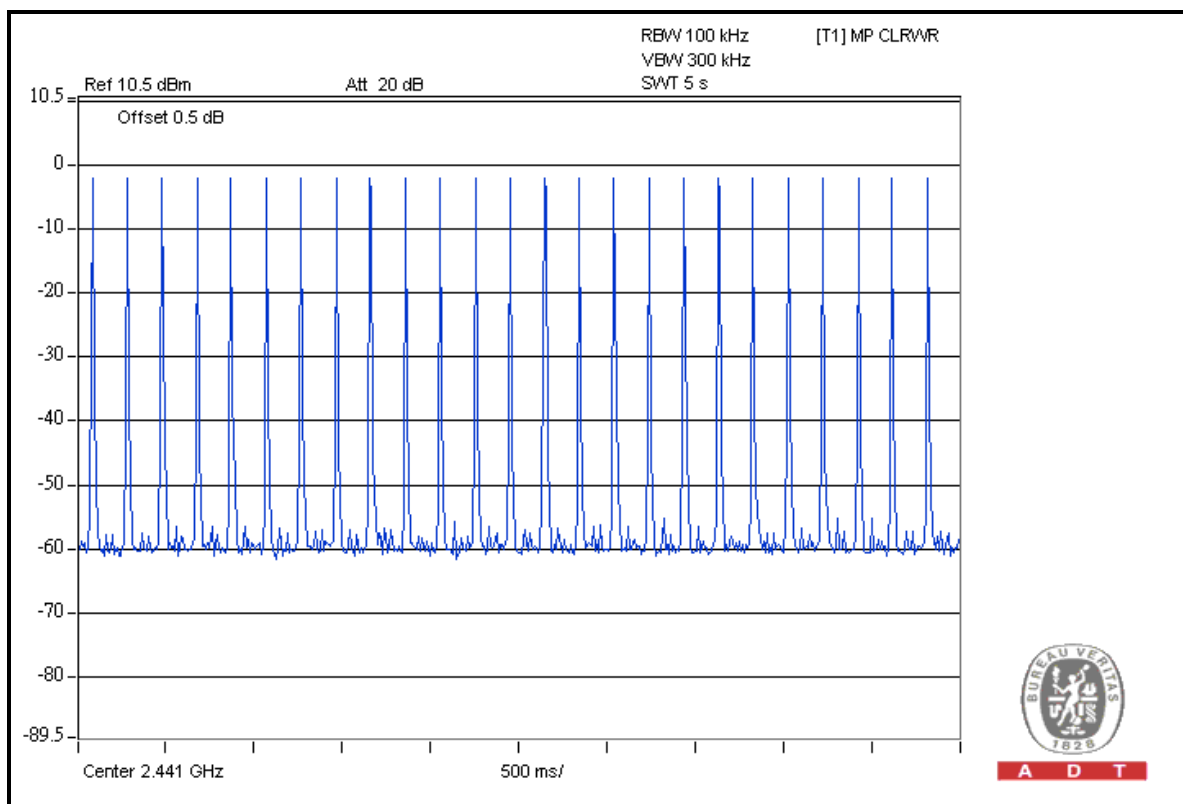



A D T

DH5

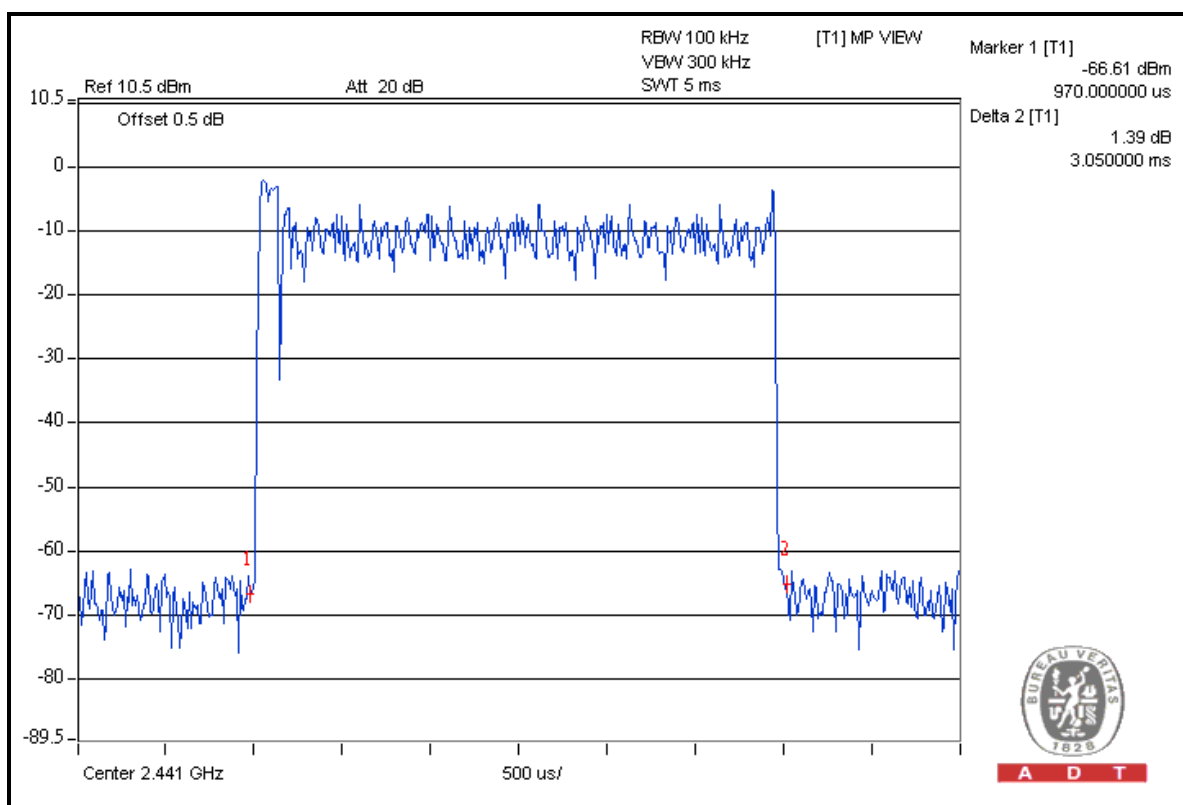
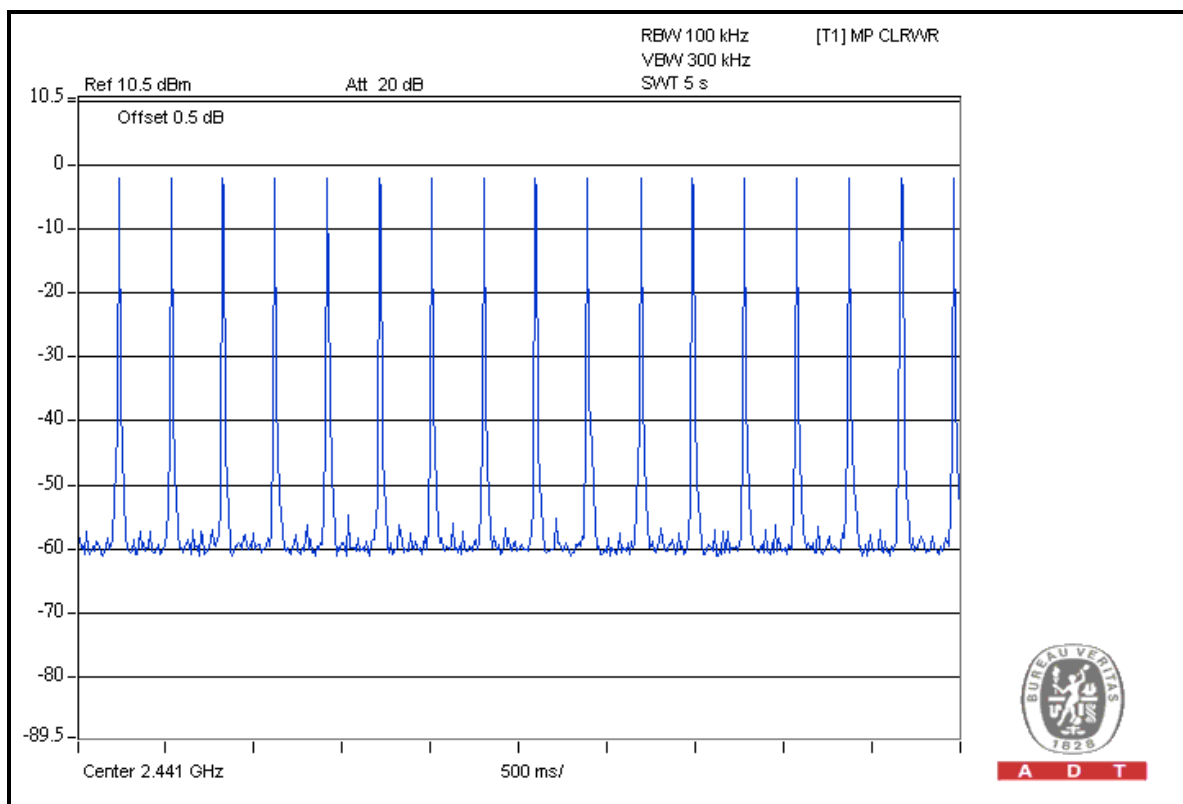

4.5 CHANNEL BANDWIDTH

4.5.1 LIMITS OF CHANNEL BANDWIDTH

For frequency hopping system operating in the 2400-2483.5MHz, If the 20dB bandwidth of hopping channel is greater than 25kHz, two-thirds 20dB bandwidth of hopping channel shall be a minimum limit for the hopping channel separation.

4.5.2 TEST INSTRUMENTS

DESCRIPTION & MANUFACTURER	MODEL NO.	SERIAL NO.	CALIBRATED DATE	CALIBRATED UNTIL
R&S Spectrum Analyzer	FSP 40	100036	Dec. 14, 2011	Dec. 13, 2012

NOTE: 1. The calibration interval of the above test instruments is 12 months and the calibrations are traceable to NML/ROC and NIST/USA.
 2. Tested: June 04, 2012

4.5.3 TEST PROCEDURE

- a. Check the calibration of the measuring instrument using either an internal calibrator or a known signal from an external generator.
- b. Turn on the EUT and connect it to measurement instrument. Then set it to any one convenient frequency within its operating range. Set a reference level on the measuring instrument equal to the highest peak value.
- c. Measure the frequency difference of two frequencies that were attenuated 20dB from the reference level. Record the frequency difference as the emission bandwidth.
- d. Repeat above procedures until all frequencies measured were complete.

4.5.4 DEVIATION FROM TEST STANDARD

No deviation

4.5.5 TEST SETUP

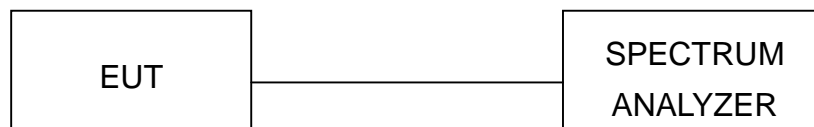

4.5.6 EUT OPERATING CONDITION

The software provided by client enabled the EUT to transmit and receive data at lowest, middle and highest channel frequencies individually.



A D T

4.5.7 TEST RESULTS

For GFSK:

CHANNEL	FREQUENCY (MHz)	20dB BANDWIDTH (MHz)
0	2402	0.93
39	2441	0.94
78	2480	0.93

CH 39

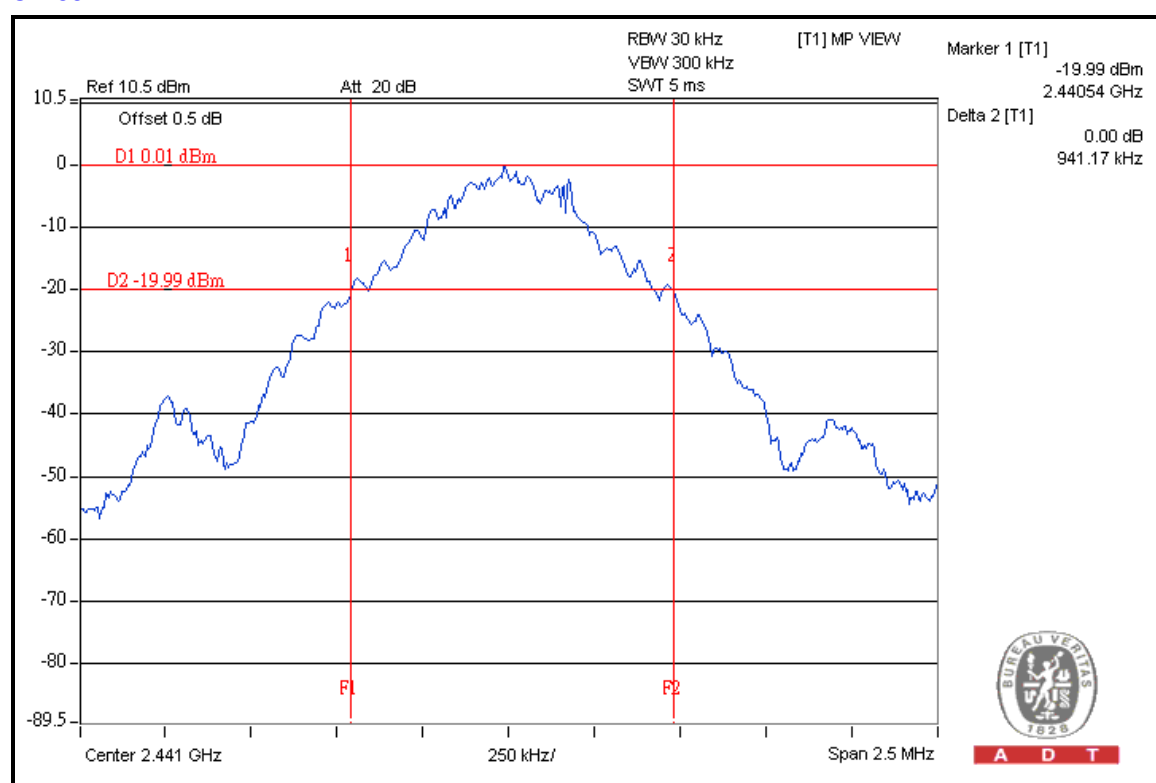



A D T

For 8DPSK:

CHANNEL	FREQUENCY (MHz)	20dB BANDWIDTH (MHz)
0	2402	1.28
39	2441	1.26
78	2480	1.26

CH 0

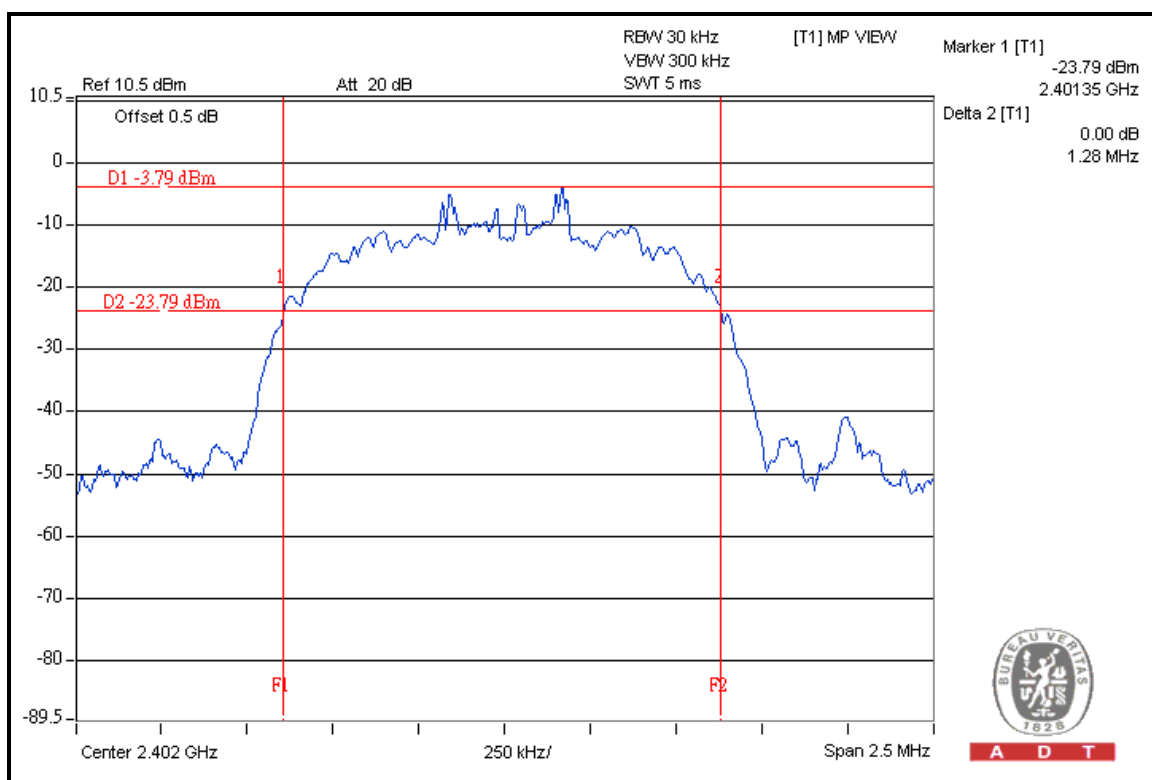

4.6 HOPPING CHANNEL SEPARATION

4.6.1 LIMIT OF HOPPING CHANNEL SEPARATION

At least 25 kHz or two-thirds of 20dB hopping channel bandwidth (whichever is greater).

4.6.2 TEST INSTRUMENTS

DESCRIPTION & MANUFACTURER	MODEL NO.	SERIAL NO.	CALIBRATED DATE	CALIBRATED UNTIL
R&S Spectrum Analyzer	FSP 40	100036	Dec. 14, 2011	Dec. 13, 2012

NOTE: 1. The calibration interval of the above test instruments is 12 months and the calibrations are traceable to NML/ROC and NIST/USA.
 2. Tested date: June 04, 2012

4.6.3 TEST PROCEDURES

- a. Check the calibration of the measuring instrument using either an internal calibrator or a known signal from an external generator.
- b. Turn on the EUT and connect it to measurement instrument. Then set it to any one convenient frequency within its operating range.
- c. By using the MaxHold function record the separation of two adjacent channels.
- d. Measure the frequency difference of these two adjacent channels by SA MARK function. And then plot the result on SA screen.
- e. Repeat above procedures until all frequencies measured were complete.

4.6.4 DEVIATION FROM TEST STANDARD

No deviation

4.6.5 TEST SETUP

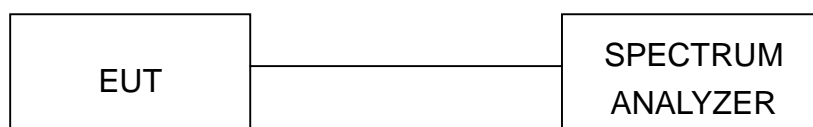



A D T

4.6.6 TEST RESULTS

For GFSK

Channel	Frequency (MHz)	Adjacent Channel Separation (MHz)	Minimum Limit (MHz)	Pass / Fail
0	2402	1.00	0.62	PASS
39	2441	1.01	0.63	PASS
78	2480	1.01	0.62	PASS

NOTE: The minimum limit is two-third 20dB bandwidth.

CH 39

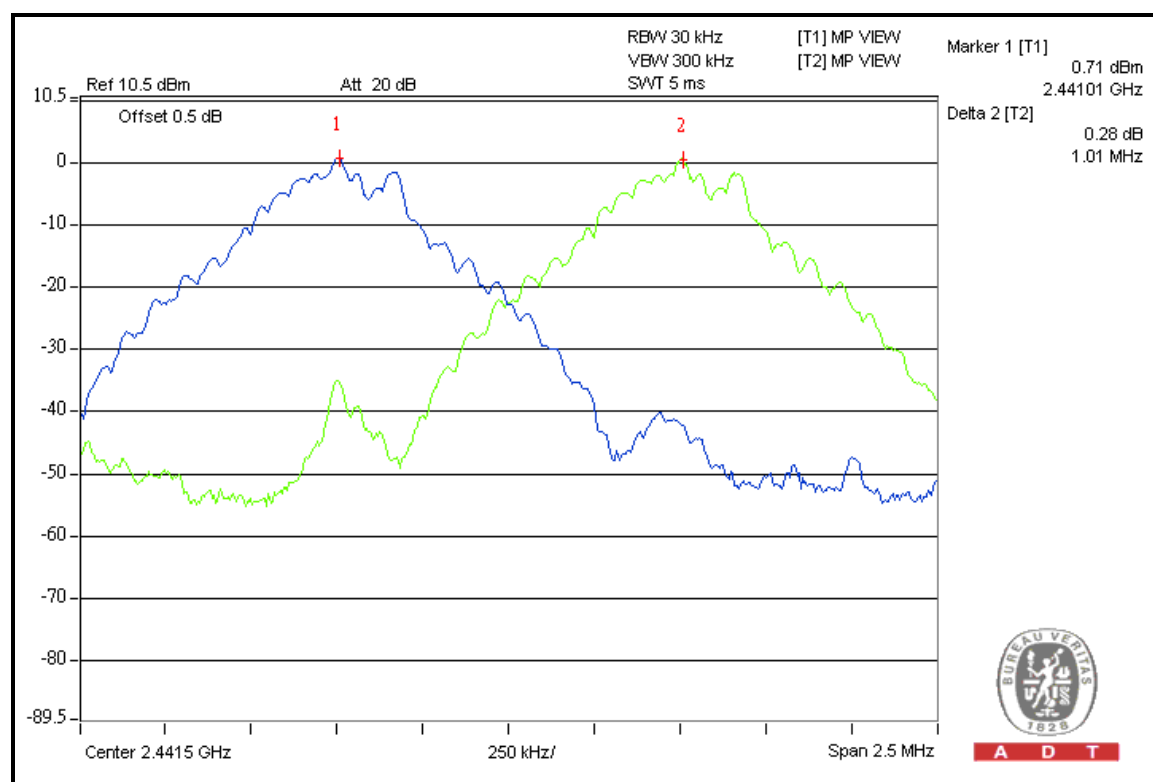



A D T

For 8DPSK

Channel	Frequency (MHz)	Adjacent Channel Separation (MHz)	Minimum Limit (MHz)	Pass / Fail
0	2402	1.01	0.85	PASS
39	2441	1.00	0.84	PASS
78	2480	1.00	0.84	PASS

NOTE: The minimum limit is two-third 20dB bandwidth.

CH 0

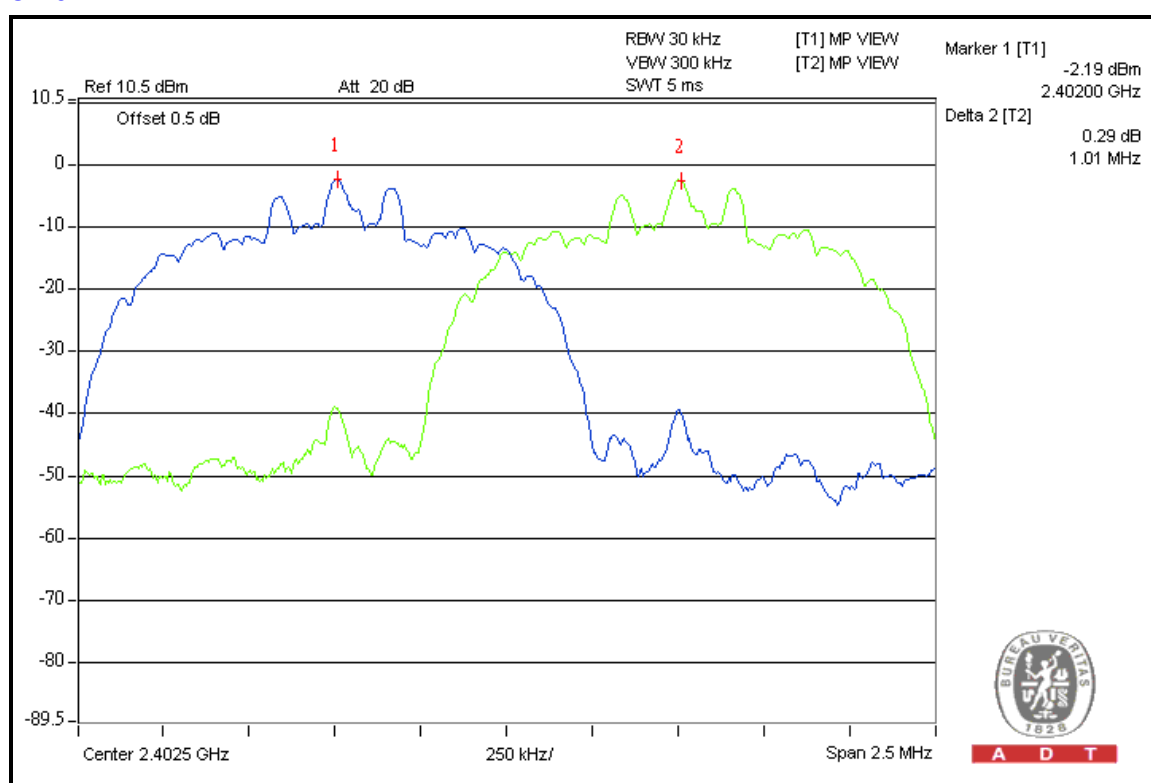

4.7 MAXIMUM PEAK OUTPUT POWER

4.7.1 LIMITS OF MAXIMUM PEAK OUTPUT POWER MEASUREMENT

The Maximum Peak Output Power Limit is 125mW.

4.7.2 INSTRUMENTS

DESCRIPTION & MANUFACTURER	MODEL NO.	SERIAL NO.	CALIBRATED DATE	CALIBRATED UNTIL
R&S Spectrum Analyzer	FSP 40	100036	Dec. 14, 2011	Dec. 13, 2012

NOTE: 1. The calibration interval of the above test instruments is 12 months and the calibrations are traceable to NML/ROC and NIST/USA.
 2. Tested date: June 04, 2012

4.7.3 TEST PROCEDURES

- a. Check the calibration of the measuring instrument using either an internal calibrator or a known signal from an external generator.
- b. Turn on the EUT and connect it to measurement instrument. Then set it to any one convenient frequency within its operating range. Set a reference level on the measuring instrument equal to the highest peak value.
- c. The center frequency of the spectrum analyzer is set to the fundamental frequency and using 3MHz RBW and 10 MHz VBW.
- d. Measure the captured power within the band and recording the plot.
- e. Repeat above procedures until all frequencies required were complete.

4.7.4 DEVIATION FROM TEST STANDARD

No deviation

4.7.5 TEST SETUP

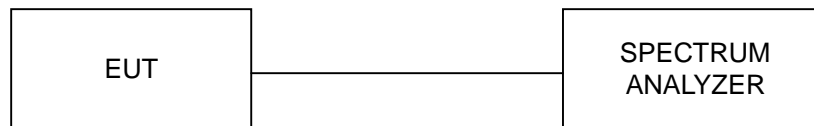

For the actual test configuration, please refer to the related Item – Photographs of the Test Configuration.

4.7.6 EUT OPERATING CONDITION

The software provided by client enabled the EUT to transmit and receive data at lowest, middle and highest channel frequencies individually.



A D T

4.7.7 TEST RESULTS

GFSK

CHANNEL	CHANNEL FREQUENCY (MHz)	POWER OUTPUT (mW)	POWER OUTPUT (dBm)	POWER LIMIT (mW)	PASS/FAIL
0	2402	1.393	1.44	125	PASS
39	2441	1.403	1.47	125	PASS
78	2480	1.403	1.47	125	PASS

CH 78

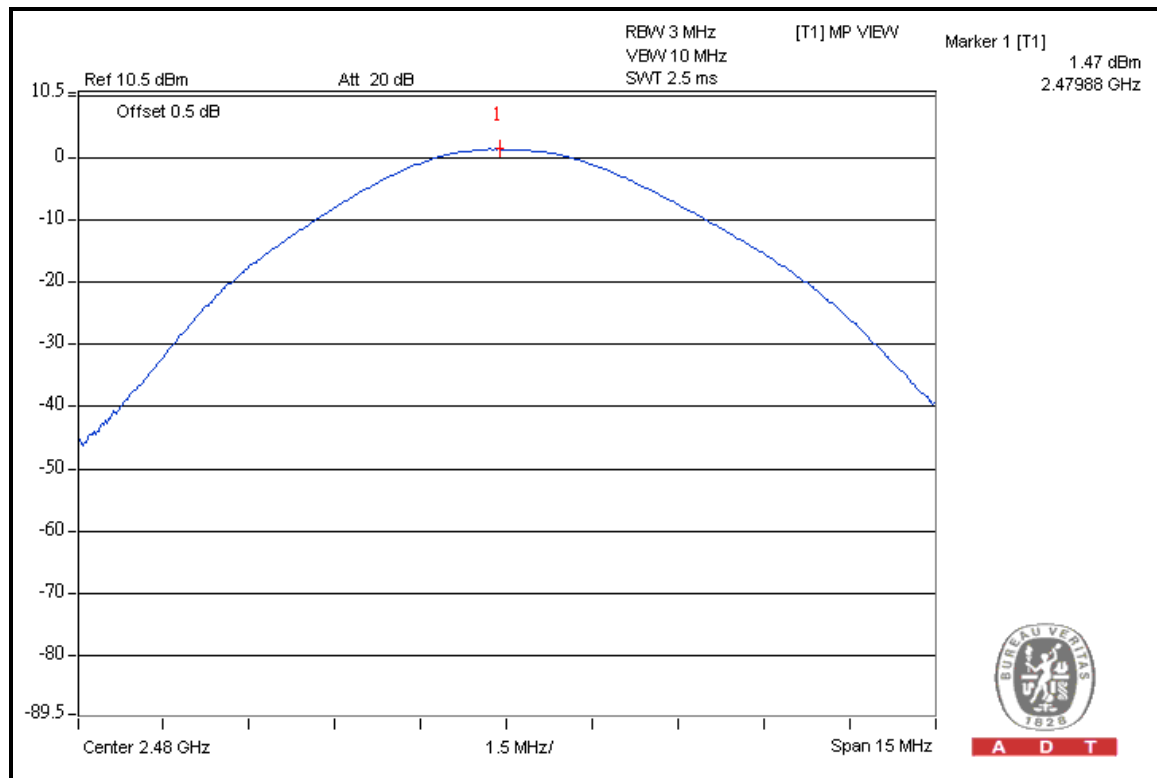



A D T

8DPSK

CHANNEL	CHANNEL FREQUENCY (MHz)	POWER OUTPUT (mW)	POWER OUTPUT (dBm)	POWER LIMIT (mW)	PASS/FAIL
0	2402	0.959	-0.18	125	PASS
39	2441	0.986	-0.06	125	PASS
78	2480	1.000	0.00	125	PASS

CH 78

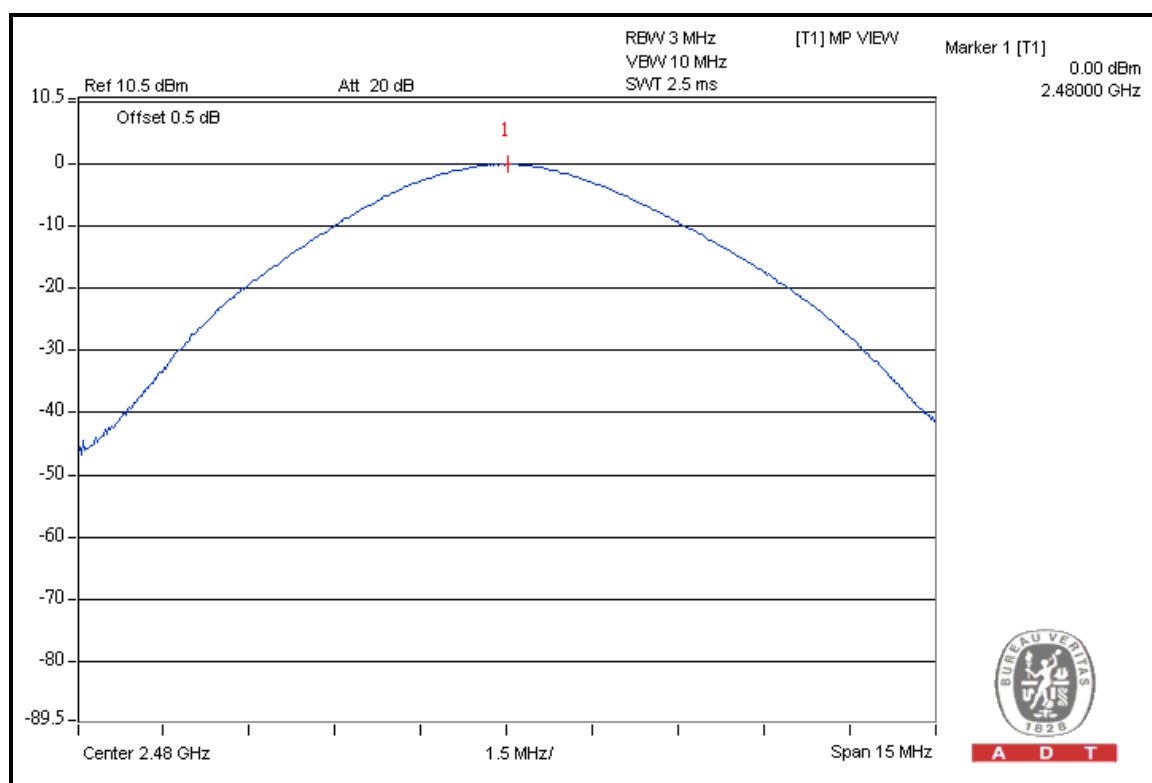

A D T

4.8 CONDUCTED OUT-BAND EMISSION MEASUREMENT

4.8.1 LIMITS OF CONDUCTED OUT-BAND EMISSION MEASUREMENT

Below -20dB of the highest emission level of operating band (in 100kHz RBW).

4.8.2 TEST INSTRUMENTS

DESCRIPTION & MANUFACTURER	MODEL NO.	SERIAL NO.	CALIBRATED DATE	CALIBRATED UNTIL
R&S Spectrum Analyzer	FSP 40	100036	Dec. 14, 2011	Dec. 13, 2012

- NOTE:** 1. The calibration interval of the above test instruments is 12 months and the calibrations are traceable to NML/ROC and NIST/USA.
2. Tested date: June 04, 2012

4.8.3 TEST PROCEDURE

The transmitter output was connected to the spectrum analyzer via a low lose cable. Set RBW a of spectrum analyzer to 100 kHz and VBW of spectrum analyzer to 300 kHz with suitable frequency span including 100 MHz bandwidth from band edge. The band edges was measured and recorded.

4.8.4 DEVIATION FROM TEST STANDARD

No deviation

4.8.5 EUT OPERATING CONDITION

The software provided by client enabled the EUT to transmit and receive data at lowest, middle and highest channel frequencies individually.

4.8.6 TEST RESULTS

The spectrum plots are attached on the following images. D1 line indicates the highest level, and D2 line indicates the 20dB offset below D1. It shows compliance with the requirement.



A D T

GFSK

Hopping disabled_Low Channel

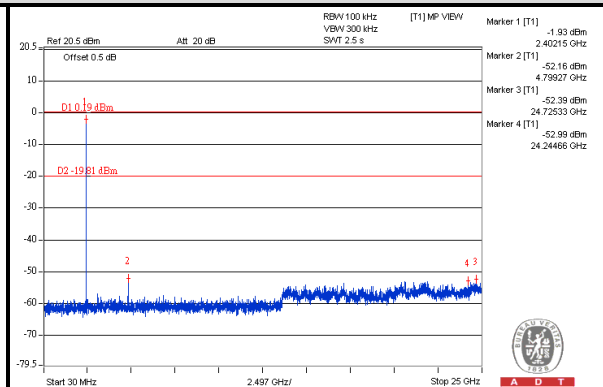
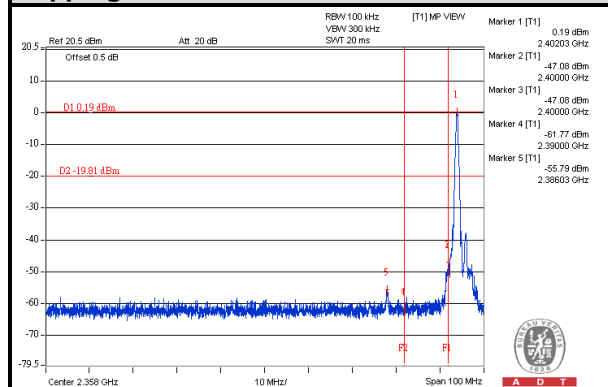

Hopping disabled_High Channel

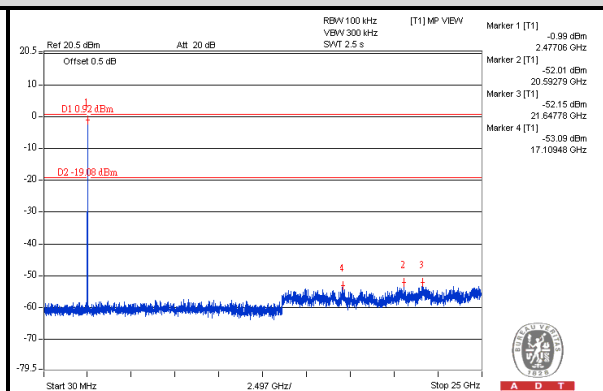
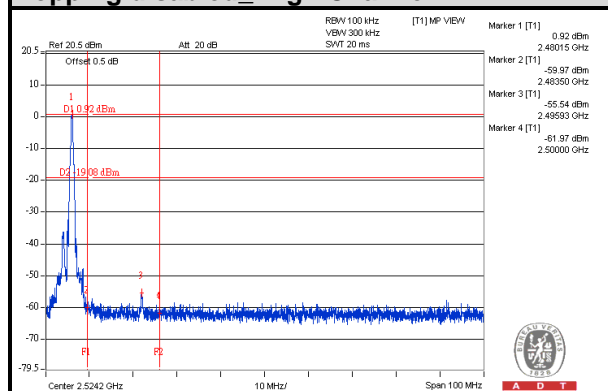

Hopping enabled_Low Channel

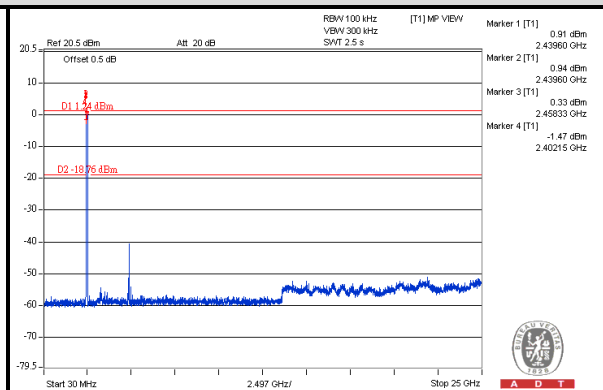
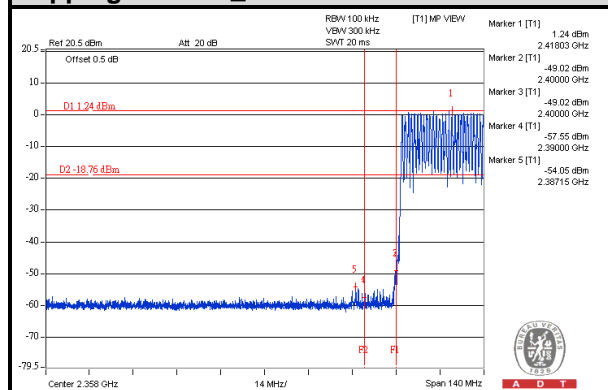

Hopping enabled_High Channel

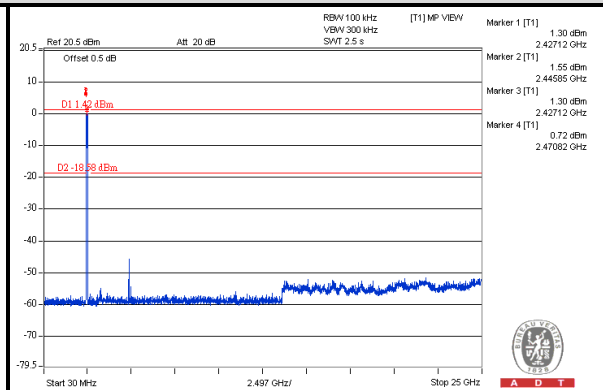
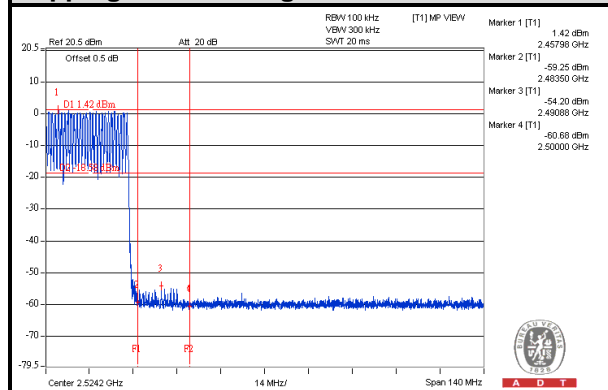



A D T

8DPSK

Hopping disabled_ Low Channel

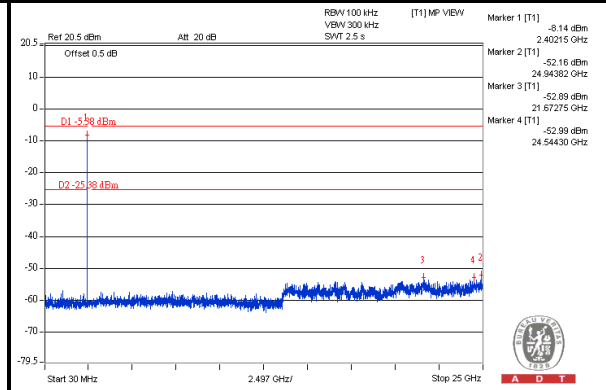
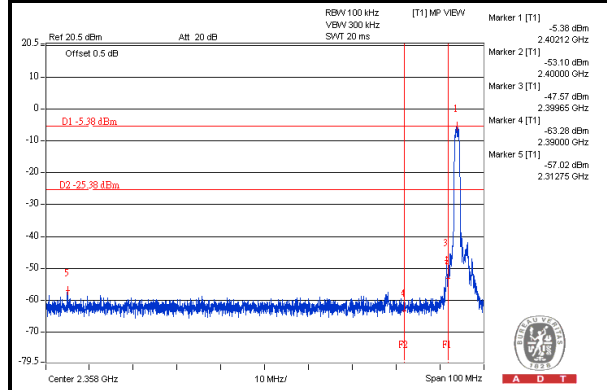

Hopping disabled_ High Channel

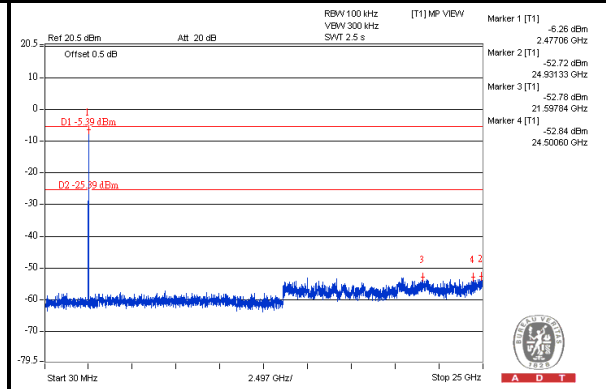
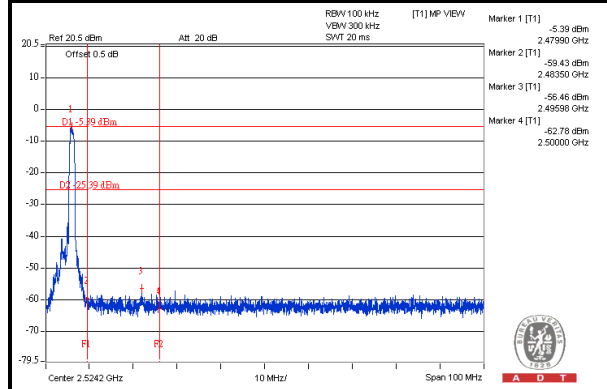

Hopping enabled_ Low Channel

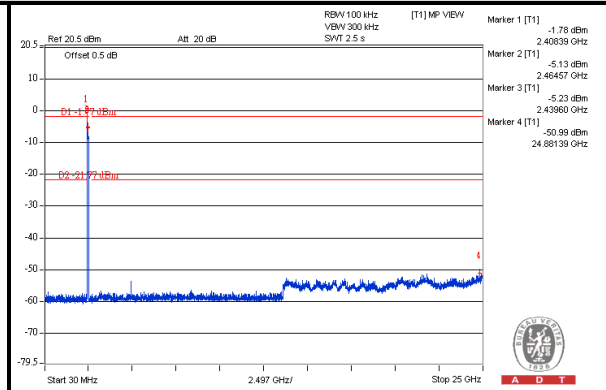
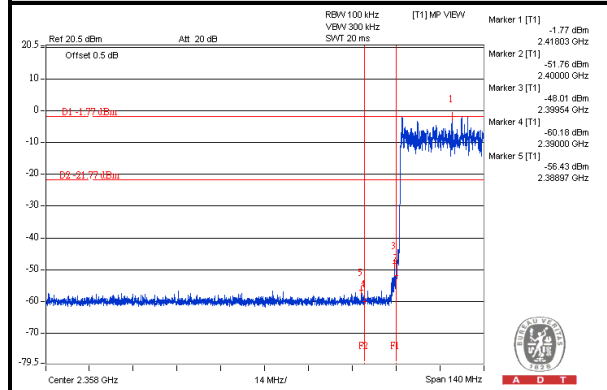

Hopping enabled_ High Channel

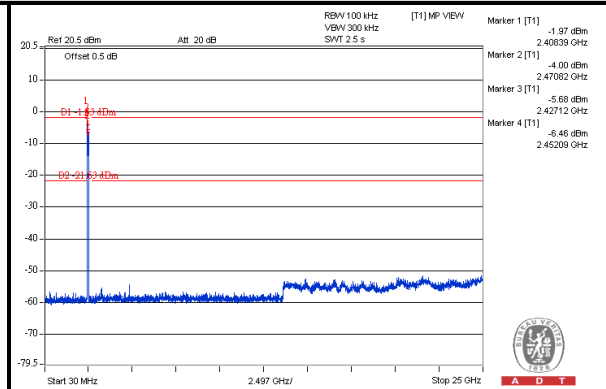
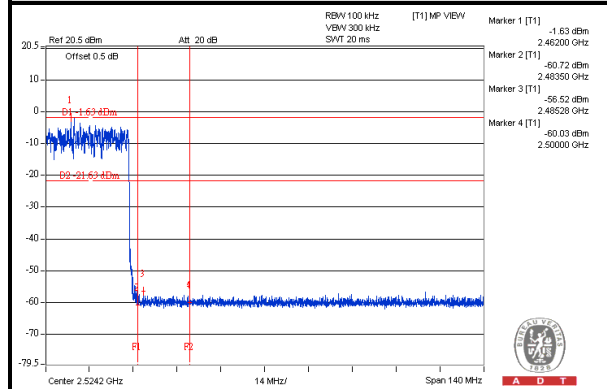



5 PHOTOGRAPHS OF THE TEST CONFIGURATION

Please refer to the attached file (Test Setup Photo).



6 INFORMATION ON THE TESTING LABORATORIES

We, Bureau Veritas Consumer Products Services (H.K.) Ltd., Taoyuan Branch, were founded in 1988 to provide our best service in EMC, Radio, Telecom and Safety consultation. Our laboratories are accredited and approved according to ISO/IEC 17025.

If you have any comments, please feel free to contact us at the following:

Linko EMC/RF Lab:

Tel: 886-2-26052180

Fax: 886-2-26052943

Hsin Chu EMC/RF Lab:

Tel: 886-3-5935343

Fax: 886-3-5935342

Hwa Ya EMC/RF/Safety/Telecom Lab:

Tel: 886-3-3183232

Fax: 886-3-3270892

Email: service.adt@tw.bureauveritas.com

Web Site: www.adt.com.tw

The address and road map of all our labs can be found in our web site also.

7 APPENDIX A - MODIFICATIONS RECORDERS FOR ENGINEERING CHANGES TO THE EUT BY THE LAB

No modifications were made to the EUT by the lab during the test.

--- END ---