



FCC TEST REPORT

REPORT NO.: RF921113H04

MODEL NO.: Y-RK56, Y-RK56A

RECEIVED: Nov. 14, 2003

TESTED: Nov. 18 to 19, 2003

APPLICANT: LOGITECH FAR EAST LTD.

ADDRESS: #2 Creation Rd. 4, Science-Based Ind. Park
Hsinchu Taiwan, R.O.C.

ISSUED BY: Advance Data Technology Corporation

LAB LOCATION: 47 14th Lin, Chia Pau Tsuen, Linkou Hsiang,
Taipei, Taiwan, R.O.C.

This test report consists of 15 pages in total. It may be duplicated completely for legal use with the approval of the applicant. It should not be reproduced except in full, without the written approval of our laboratory. The client should not use it to claim product endorsement by NVLAP or any U.S. government agencies. The test results in the report only apply to the tested sample.



0536
ILAC MRA



Lab Code: 200376-0



Table of Contents

1	CERTIFICATION	3
2	SUMMARY OF TEST RESULTS	4
3	GENERAL INFORMATION.....	5
3.1	GENERAL DESCRIPTION OF EUT	5
3.2	DESCRIPTION OF TEST MODES	6
3.3	GENERAL DESCRIPTION OF APPLIED STANDARDS.....	6
3.4	DESCRIPTION OF SUPPORT UNITS	7
4	TEST PROCEDURE AND RESULT	8
4.1	CONDUCTED EMISSION MEASUREMENT	8
4.2	RADIATED EMISSION MEASUREMENT	8
4.2.1	LIMITS OF RADIATED EMISSION MEASUREMENT	8
4.2.2	TEST INSTRUMENT	9
4.2.3	TEST PROCEDURE	10
4.2.4	DEVIATION FROM TEST STANDARD	10
4.2.5	TEST SETUP	11
4.2.6	EUT OPERATING CONDITION	11
4.2.7	TEST RESULT	12
5	PHOTOGRAPHS OF THE TEST CONFIGURATION	14
6	INFORMATION ON THE TESTING LABORATORIES	15



1 CERTIFICATION

PRODUCT : Wireless Keyboard
BRAND NAME : Logitech
MODEL NO : Y-RK56, Y-RK56A
APPLICANT : LOGITECH FAR EAST LTD.
STANDARDS : 47 CFR Part 15, Subpart C (15.227)
ANSI C63.4-1992

We, **Advance Data Technology Corporation**, hereby certify that one sample of the designation has been tested in our facility on Nov. 18 to 19, 2003. The test record, data evaluation and Equipment Under Test (EUT) configurations represented herein are true and accurate accounts of the measurements of the sample's EMC characteristics under the conditions herein specified.

PREPARED BY: Carol Liao, **DATE:** Nov. 24, 2003
(Carol Liao)

APPROVED BY: Eric Lin, **DATE:** Nov. 24, 2003
(Eric Lin, Manager)



2 SUMMARY OF TEST RESULTS

The EUT has been tested according to the following specifications:

APPLIED STANDARD: 47 CFR Part 15, Subpart C			
STANDARD PARAGRAPH	TEST TYPE	RESULT	REMARK
15.207	Conducted Emission Test	N/A	Power supply is 3VDC from batteries
15.227	Radiated Emission Test	PASS	Minimum passing margin is -8.10 dBuV at 135.72 MHz

NOTE: The receiver part to communicate with the EUT has been verified to comply with FCC Part 15, Subpart B, Class B (DoC). The test report can be provided upon request.

3 GENERAL INFORMATION

3.1 GENERAL DESCRIPTION OF EUT

PRODUCT	Wireless Keyboard
MODEL NO.	Y-RK56, Y-RK56A
POWER SUPPLY	3VDC from battery
MODULATION TYPE	FSK
CARRIER FREQUENCY OF EACH CHANNEL	27.095MHz & 27.145MHz
NUMBER OF CHANNEL	2
ANTENNA TYPE	Loop antenna
DATA CABLE	NA
I/O PORTS	NA
ASSOCIATED DEVICES	NA

NOTE:

1. The EUT is the transmitter part of Wireless Keyboard.
2. The EUT has two model numbers that are identical to each other in all aspects except for out-looking.
3. For more detailed features description of the EUT, please refer to the manufacturer's specifications or the User's Manual.



3.2 DESCRIPTION OF TEST MODES

There are two channels have been pretested in our facility which are identical to each other in all aspects except for the following:

Mode	Frequency
1	27.145MHz
2	27.095MHz

NOTE: 1 channel sample, the worst case, was chosen for final test and it's data was recorded in this report as bellows,

Mode	Frequency
1	27.145MHz

3.3 GENERAL DESCRIPTION OF APPLIED STANDARDS

The EUT is the transmitter part of a Wireless Keyboard. According to the specifications of the manufacturer, it must comply with the requirements of the following standards:

47 CFR Part 15, Subpart C (15.227)

ANSI C63.4-1992

All tests have been performed and recorded as per the above standards.



3.4 DESCRIPTION OF SUPPORT UNITS

The EUT has been tested as an independent unit together with other necessary accessories or support units. The following support units or accessories were used to form a representative test configuration during the tests.

No.	Product	Brand	Model No.	Serial No.	FCC ID
1	PERSONAL COMPUTER	COMPAQ	D320UT	TDC6Q-JC8PM-2R99 Q-J,D76-C3FGJ	DoC
2	COLOR MONITOR	ADI	CM100	026058T10200636 A	DOC
3	Matrix Printer	EPSON	LQ-300+	DCGY017097	DOC
4	MODEM	ACEEX	1414	0206026772	IFAXDM1414
5	RECEIVER	Logitech	C-BG17-DUAL	LZB32300001	DoC
6	MOUSE	IBM	M-SAU-IBM6	23-043138	JNZ211220

No.	Signal cable description
1	NA
2	1.8 m braid shielded wire, terminated with VGA connector via metallic frame, w/o core
3	1.8 m braid shielded wire, terminated with DB25 and Centronics connector via metallic frame, w/o core.
4	1.0 m braid shielded wire, terminated with DB25 and DB9 connector via metallic frame, w/o core.
5	NA
6	1.8 m foil shielded wire, terminal by frame, PS2 Connector, w/o Core.NA

Note: 1. The power cords of the above support units were unshielded (1.8m).

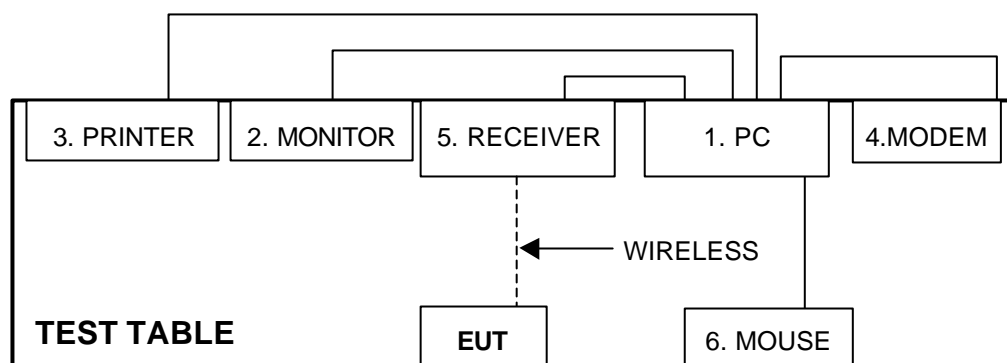

NOTE: 1. Please refer to the photos of test configuration in Item 6 also.

4 TEST PROCEDURE AND RESULT

4.1 CONDUCTED EMISSION MEASUREMENT

NA

4.2 RADIATED EMISSION MEASUREMENT

4.2.1 LIMITS OF RADIATED EMISSION MEASUREMENT

According to 15.227 the field strength of emissions from intentional radiators operated under these frequencies bands shall not exceed the following:

Fundamental Frequency (MHz)	Field Strength of Fundamental (dBuV/m)	
	Peak	Average
26.96-27.28	100	80

Emissions radiated outside of the specified bands, shall be according to the general radiated limits in 15.209 as following:

Frequencies (MHz)	Field strength (microvolts/meter)	Measurement distance (meters)
0.009-0.490	2400/F(kHz)	300
0.490-1.705	24000/F(kHz)	30
1.705-30.0	30	30
30-88	100	3
88-216	150	3
216-960	200	3
Above 960	500	3

As shown in 15.35(b), for frequencies above 1000MHz, the field strength limits are based on average detector, however, the peak field strength of any emission shall not exceed the maximum permitted average limits, specified above by more than 20dB under any condition of modulation.



4.2.2 TEST INSTRUMENT

DESCRIPTION & MANUFACTURER	MODEL NO.	SERIAL NO.	CALIBRATED UNTIL
HP Spectrum Analyzer	8594ER	3829U04676	Jul. 14, 2004
ADVANTEST Spectrum Analyzer	R3271A	85060311	Jun. 16, 2004
CHASE RF Pre_Amplifier	CPA9232	1057	May. 10, 2004
HP Pre_Amplifier	8449B	3008A01281	Dec. 27, 2003
ROHDE & SCHWARZ Test Receiver	ESVS 10	849231 /019	Sep. 30, 2004
CHASE Broadband Antenna	CBL6111c	2730	Jul 30, 2004
Schwarzbeck Horn_Antenna	BBHA9120-D1	D123	Sep. 24, 2004
SCHWARZBECK Tunable Dipole Antenna	UHAP	897	Mar. 07, 2005
SCHWARZBECK Tunable Dipole Antenna	VHAP	880	Mar. 07, 2005
R&S Loop Antenna	HFH2-Z2	881058/15	Mar. 07, 2004
RF Switches (ARNITSU)	CS-201	1565157	Jul. 29, 2004
RF CABLE (Chaintek) 1GHz-20GHz	Ak 9515-D	001	Aug, 20, 2004
RF Cable(RICHTEC)	9913-30M	STCCAB-30M-1GH z-021	Nov. 5, 2004
Software	AS60P8	NA	NA
CHANCE MOST Antenna Tower	AT-100	0203	NA
CHANCE MOST Turn Table	TT-100	0203	NA

Note: 1. The calibration interval of the above test instruments is 12 months (36 months for Tunable Dipole Antenna) and the calibrations are traceable to NML/ROC and NIST/USA.

2. * = These equipment are used for the final measurement.
3. The horn antenna and HP preamplifier (model: 8449B) are used only for the measurement of emission frequency above 1GHz if tested.
4. The test was performed in ADT Open Site No. C.
5. The FCC Site Registration No. is 656396.
6. The VCCI Site Registration No. is R-1626.



4.2.3 TEST PROCEDURE

- a. The EUT was placed on the top of a rotating table 0.8 meters above the ground at a 10 meter open area test site. The table was rotated 360 degrees to determine the position of the highest radiation.
- b. The EUT was set 3 meters away from the interference-receiving antenna, which was mounted on the top of a variable-height antenna tower.
- c. The antenna is a broadband antenna, and its height is varied from one meter to four meters above the ground to determine the maximum value of the field strength. Both horizontal and vertical polarizations of the antenna are set to make the measurement.
- d. For each suspected emission, the EUT was arranged to its worst case and then the antenna was tuned to heights from 1 meter to 4 meters and the rotatable table was turned from 0 degrees to 360 degrees to find the maximum reading.
- e. The test-receiver system was set to Peak Detect Function and Specified Bandwidth with Maximum Hold Mode.
- f. If the emission level of the EUT in peak mode was 10 dB lower than the limit specified, then testing could be stopped and the peak values of the EUT would be reported. Otherwise the emissions that did not have 10 dB margin would be re-tested one by one using the quasi-peak method or average method as specified and then reported in Data sheet peak mode and QP mode.

NOTE:

1. The resolution bandwidth and video bandwidth of test receiver/spectrum analyzer is 120kHz for Peak detection (PK) and Quasi-peak detection (QP) at frequency below 1GHz.
2. The resolution bandwidth and video bandwidth of test receiver/spectrum analyzer is 1 MHz for Peak detection at frequency above 1GHz.
3. The resolution bandwidth of test receiver/spectrum analyzer is 1 MHz and the video bandwidth is 300 Hz for Average detection (AV) at frequency above 1GHz.

4.2.4 DEVIATION FROM TEST STANDARD

No deviation

4.2.5 TEST SETUP

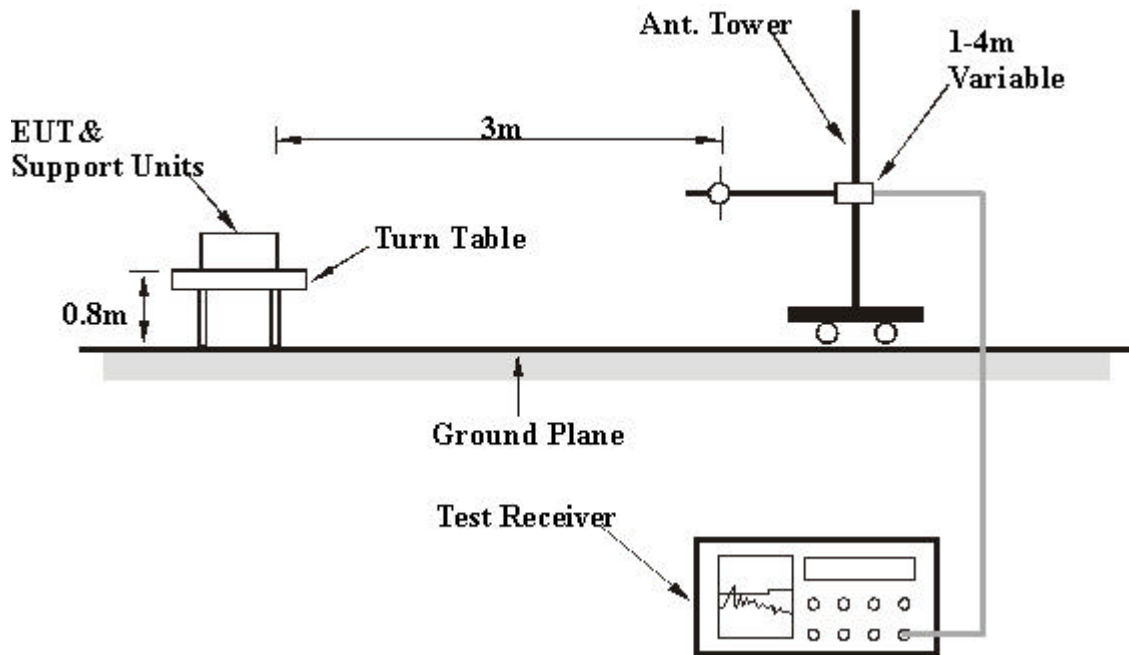

For the actual test configuration, please refer to the related item in this test report - Photographs of the Test Configuration.

4.2.6 EUT OPERATING CONDITION

Set the transmitter part of EUT under transmission condition continuously at specific channel frequency.

4.2.7 TEST RESULT

EUT	Wireless Keyboard	MODEL	Y-RK56
MODE	27.145MHz	INPUT POWER	3VDC
FREQUENCY RANGE	Below 1000 MHz	DETECTOR FUNCTION	Peak / Quasi-Peak / Average
ENVIRONMENTAL CONDITIONS	28 deg. C, 69 % RH, 965 hPa	TEST BY	Eric Lee

ANTENNA POLARITY & TEST DISTANCE: HORIZONTAL AT 3 M								
No.	Freq. (MHz)	Emission Level (dBuV/m)	Limit (dBuV/m)	Margin (dB)	Antenna Height (m)	Table Angle (Degree)	Raw Value (dBuV)	Correction Factor (dB/m)
1	*27.14	61.40 PK	100.0	-38.60	2.37 H	319	42.00	19.40
2	*27.14	40.20 AV	80.00	-39.80	2.37 H	319	20.80	19.40
3	81.45	21.10 QP	40.00	-18.90	2.10 H	320	12.50	8.60
4	108.59	26.90 QP	43.50	-16.60	2.68 H	345	15.10	11.80
5	135.72	35.40 QP	43.50	-8.10	2.33 H	358	22.70	12.60
6	217.19	26.90 QP	46.00	-19.10	1.14 H	279	16.60	10.30
7	244.30	32.90 QP	46.00	-13.10	1.75 H	48	19.30	13.60
8	298.58	33.80 QP	46.00	-12.20	1.22 H	114	18.40	15.40
9	407.23	34.30 QP	46.00	-11.70	1.06 H	135	15.30	19.00
10	434.37	37.40 QP	46.00	-8.60	1.00 H	91	17.60	19.80
11	488.65	32.40 QP	46.00	-13.60	1.00 H	88	11.00	21.30
12	542.97	31.00 QP	46.00	-15.00	1.00 H	95	8.30	22.70

- REMARKS:**
1. Emission level(dBuV/m)=Raw Value(dBuV) + Correction Factor(dB)
 2. Correction Factor(dB/m) = Antenna Factor (dB/m) + Cable Factor (dB)
 3. The other emission levels were very low against the limit.
 4. Margin value = Emission level – Limit value.
 5. "*" = Fundamental frequency.



EUT	Wireless Keyboard	MODEL	Y-RK56
MODE	27.145MHz	INPUT POWER	3VDC
FREQUENCY RANGE	Below 1000 MHz	DETECTOR FUNCTION	Peak / Quasi-Peak / Average
ENVIRONMENTAL CONDITIONS	28 deg. C, 69 % RH, 965 hPa	TEST BY	Eric Lee

ANTENNA POLARITY & TEST DISTANCE: VERTICAL AT 3 M

No.	Freq. (MHz)	Emission Level (dBuV/m)	Limit (dBuV/m)	Margin (dB)	Antenna Height (m)	Table Angle (Degree)	Raw Value (dBuV)	Correction Factor (dB/m)
1	*27.14	45.70 PK	100.0	-54.30	1.15 V	355	26.40	19.40
2	*27.14	32.60 AV	80.00	-47.40	1.15 V	355	13.20	19.40
3	135.72	23.90 QP	43.50	-19.60	1.00 V	223	11.30	12.60
4	190.04	18.50 QP	43.50	-25.00	1.00 V	68	8.30	10.20
5	217.19	21.10 QP	46.00	-24.90	1.03 V	98	10.80	10.30
6	244.29	25.90 QP	46.00	-20.10	1.04 V	5	12.30	13.60
7	271.43	22.40 QP	46.00	-23.60	1.00 V	320	7.60	14.70
8	298.58	27.40 QP	46.00	-18.60	1.00 V	49	12.00	15.40
9	325.77	20.80 QP	46.00	-25.20	1.98 V	23	4.60	16.10
10	434.37	28.30 QP	46.00	-17.70	1.96 V	325	8.50	19.80
11	461.52	25.80 QP	46.00	-20.20	1.85 V	246	5.30	20.50
12	488.67	25.80 QP	46.00	-20.20	1.94 V	11	4.50	21.30

- REMARKS:**
1. Emission level(dBuV/m)=Raw Value(dBuV) + Correction Factor(dB)
 2. Correction Factor(dB/m) = Antenna Factor (dB/m) + Cable Factor (dB)
 3. The other emission levels were very low against the limit.
 4. Margin value = Emission level – Limit value.
 5. "*" = Fundamental frequency.

5 PHOTOGRAPHS OF THE TEST CONFIGURATION RADIATED EMISSION TEST





6 INFORMATION ON THE TESTING LABORATORIES

We, ADT Corp., were founded in 1988 to provide our best service in EMC and Safety consultation. Our laboratories are accredited and approved by the following approval agencies according to ISO/IEC 17025, Guide 25 or EN 45001:

USA	FCC, NVLAP
Germany	TUV Rheinland
Japan	VCCI
New Zealand	MoC
Norway	NEMKO
R.O.C.	BSMI, DGT, CNLA

Copies of accreditation certificates of our laboratories obtained from approval agencies can be downloaded from our web site: www.adt.com.tw/index.5/phtml.
If you have any comments, please feel free to contact us at the following:

Lin Kou EMC Lab:
Tel: 886-2-26052180
Fax: 886-2-26052943

Hsin Chu EMC Lab:
Tel: 886-35-935343
Fax: 886-35-935342

Lin Kou Safety Lab:
Tel: 886-2-26093195
Fax: 886-2-26093184

Lin Kou RF&Telecom Lab:
Tel: 886-3-3270910
Fax: 886-3-3270892

Email: service@adt.com.tw
Web Site: www.adt.com.tw

The address and road map of all our labs can be found in our web site also.