

# TEST REPORT

## CERTIFICATE OF CONFORMITY

**Standard:** 47 CFR FCC Part 15, Subpart C (Section 15.247)

**Report No.:** RFBDKG-WTW-P23080559

**FCC ID:** JNZCU0026

**Product:** Wireless USB Dongle

**Brand:** Logitech, logi, logitech

**Model No.:** CU0026

**Received Date:** 2023/8/25

**Test Date:** 2023/9/7 ~ 2023/9/27

**Issued Date:** 2023/11/15

**Applicant:** Logitech Far East Ltd.

**Address:** #2 Creation Rd. 4, Science-Based Ind. Park Hsinchu Taiwan, R.O.C.

**Issued By:** Bureau Veritas Consumer Products Services (H.K.) Ltd., Taoyuan Branch  
Hsin Chu Laboratory

**Lab Address:** E-2, No.1, Li Hsin 1st Road, Hsinchu Science Park, Hsinchu City 300, Taiwan

**Test Location:** E-2, No.1, Li Hsin 1st Road, Hsinchu Science Park, Hsinchu City 300, Taiwan

**FCC Registration /** 723255 / TW2022

**Designation Number:**

Approved by: \_\_\_\_\_



, Date: \_\_\_\_\_

2023/11/15

Wen Yu / Assistant Manager

This test report consists of 39 pages in total. It may be duplicated completely for legal use with the approval of the applicant. It should not be reproduced except in full, without the written approval of our laboratory. The test results in the report only apply to the tested sample. The test results in this report are traceable to the national or international standards.



Prepared by : Phoenix Huang / Specialist

This report is governed by, and incorporates by reference, the Conditions of Testing as posted at the date of issuance of this report at <http://www.bureauveritas.com/home/about-us/our-business/cps/about-us/terms-conditions/> and is intended for your exclusive use. Any copying or replication of this report to or for any other person or entity, or use of our name or trademark, is permitted only with our prior written permission. This report sets forth our findings solely with respect to the test samples identified herein. The results set forth in this report are not indicative or representative of the quality or characteristics of the lot from which a test sample was taken or any similar or identical product unless specifically and expressly noted. Our report includes all of the tests requested by you and the results thereof based upon the information that you provided to us. Measurement uncertainty is only provided upon request for accredited tests. Statements of conformity are based on simple acceptance criteria without taking measurement uncertainty into account, unless otherwise requested in writing. You have 60 days from date of issuance of this report to notify us of any material error or omission caused by our negligence or if you require measurement uncertainty; provided, however, that such notice shall be in writing and shall specifically address the issue you wish to raise. A failure to raise such issue within the prescribed time shall constitute your unqualified acceptance of the completeness of this report, the tests conducted and the correctness of the report contents.

## Table of Contents

<b>Release Control Record</b> .....	<b>4</b>
<b>1 Certificate</b> .....	<b>5</b>
<b>2 Summary of Test Results</b> .....	<b>6</b>
2.1 Measurement Uncertainty .....	6
2.2 Supplementary Information .....	6
<b>3 General Information</b> .....	<b>7</b>
3.1 General Description .....	7
3.2 Antenna Description of EUT .....	7
3.3 Channel List .....	8
3.4 Test Mode Applicability and Tested Channel Detail .....	9
3.5 Duty Cycle of Test Signal .....	9
3.6 Test Program Used and Operation Descriptions .....	10
3.7 Connection Diagram of EUT and Peripheral Devices .....	10
3.8 Configuration of Peripheral Devices and Cable Connections .....	10
<b>4 Test Instruments</b> .....	<b>11</b>
4.1 RF Output Power .....	11
4.2 Power Spectral Density .....	11
4.3 6 dB Bandwidth .....	11
4.4 Conducted Out of Band Emissions .....	11
4.5 AC Power Conducted Emissions .....	12
4.6 Unwanted Emissions below 1 GHz .....	12
4.7 Unwanted Emissions above 1 GHz .....	13
<b>5 Limits of Test Items</b> .....	<b>14</b>
5.1 RF Output Power .....	14
5.2 Power Spectral Density .....	14
5.3 6 dB Bandwidth .....	14
5.4 Conducted Out of Band Emissions .....	14
5.5 AC Power Conducted Emissions .....	14
5.6 Unwanted Emissions below 1 GHz .....	14
5.7 Unwanted Emissions above 1 GHz .....	15
<b>6 Test Arrangements</b> .....	<b>16</b>
6.1 RF Output Power .....	16
6.1.1 Test Setup .....	16
6.1.2 Test Procedure .....	16
6.2 Power Spectral Density .....	16
6.2.1 Test Setup .....	16
6.2.2 Test Procedure .....	16
6.3 6 dB Bandwidth .....	17
6.3.1 Test Setup .....	17
6.3.2 Test Procedure .....	17
6.4 Conducted Out of Band Emissions .....	17
6.4.1 Test Setup .....	17
6.4.2 Test Procedure .....	17
6.5 AC Power Conducted Emissions .....	18
6.5.1 Test Setup .....	18
6.5.2 Test Procedure .....	18
6.6 Unwanted Emissions below 1 GHz .....	19
6.6.1 Test Setup .....	19
6.6.2 Test Procedure .....	20
6.7 Unwanted Emissions above 1 GHz .....	21
6.7.1 Test Setup .....	21
6.7.2 Test Procedure .....	21
<b>7 Test Results of Test Item</b> .....	<b>22</b>



7.1	RF Output Power.....	22
7.2	Power Spectral Density.....	23
7.3	6 dB Bandwidth.....	24
7.4	Conducted Out of Band Emissions.....	25
7.5	AC Power Conducted Emissions.....	26
7.6	Unwanted Emissions below 1 GHz.....	28
7.7	Unwanted Emissions above 1 GHz.....	30
<b>8</b>	<b>Pictures of Test Arrangements.....</b>	<b>38</b>
<b>9</b>	<b>Information of the Testing Laboratories.....</b>	<b>39</b>



## Release Control Record

Issue No.	Description	Date Issued
RFBDKG-WTW-P23080559	Original release.	2023/11/15

## 1 Certificate

**Product:** Wireless USB Dongle

**Brand:** Logitech, logi, logitech

**Test Model:** CU0026

**Sample Status:** Engineering sample

**Applicant:** Logitech Far East Ltd.

**Test Date:** 2023/9/7 ~ 2023/9/27

**Standard:** 47 CFR FCC Part 15, Subpart C (Section 15.247)

**Measurement** ANSI C63.10-2013

**procedure:** KDB 558074 D01 15.247 Meas Guidance v05r02

The above equipment has been tested by **Bureau Veritas Consumer Products Services (H.K.) Ltd., Taoyuan Branch**, and found compliance with the requirement of the above standards. The test record, data evaluation & Equipment Under Test (EUT) configurations represented herein are true and accurate accounts of the measurements of the sample's RF characteristics under the conditions specified in this report.

## 2 Summary of Test Results

47 CFR FCC Part 15, Subpart C (Section 15.247)			
Standard / Clause	Test Item	Result	Remark
15.247(b)	RF Output Power	Pass	Meet the requirement of limit.
15.247(e)	Power Spectral Density	Pass	Meet the requirement of limit.
15.247(a)(2)	6 dB Bandwidth	Pass	Meet the requirement of limit.
15.247(d)	Conducted Out of Band Emissions	Pass	Meet the requirement of limit.
15.207	AC Power Conducted Emissions	Pass	Minimum passing margin is -15.43 dB at 0.57577 MHz
15.205 / 15.209 / 15.247(d)	Unwanted Emissions below 1 GHz	Pass	Minimum passing margin is -7.6 dB at 33.61 MHz
15.205 / 15.209 / 15.247(d)	Unwanted Emissions above 1 GHz	Pass	Minimum passing margin is -7.6 dB at 2390.00 MHz
15.203	Antenna Requirement	Pass	No antenna connector is used.

Note: Determining compliance based on the results of the compliance measurement, not taking into account measurement instrumentation uncertainty.

### 2.1 Measurement Uncertainty

Where relevant, the following measurement uncertainty levels have been estimated for tests performed on the EUT as specified in CISPR 16-4-2:

Measurement	Specification	Expanded Uncertainty (k=2) (±)
Conducted Out of Band Emissions	9 kHz ~ 40 GHz	2.5 dB
AC Power Conducted Emissions	150 kHz ~ 30 MHz	1.9 dB
Unwanted Emissions below 1 GHz	9 kHz ~ 30 MHz	3.1 dB
	30 MHz ~ 1 GHz	5.4 dB
Unwanted Emissions above 1 GHz	1 GHz ~ 18 GHz	5.0 dB
	18 GHz ~ 40 GHz	5.3 dB

The other instruments specified are routine verified to remain within the calibrated levels, no measurement uncertainty is required to be calculated.

### 2.2 Supplementary Information

There is not any deviation from the test standards for the test method, and no modifications required for compliance.

### 3 General Information

#### 3.1 General Description

Product	Wireless USB Dongle
Brand	Logitech, logi, logitech
Test Model	CU0026
Status of EUT	Engineering sample
Power Supply Rating	5 Vdc from USB interface
Modulation Type	GFSK
Modulation Technology	DTS
Transfer Rate	2 Mbps
Operating Frequency	2.405 GHz ~ 2.474 GHz
Number of Channel	70
Output Power	6.368 mW (8.04 dBm)

Note:

1. The EUT may have a lot of colors for marketing requirement.
2. The above EUT information is declared by manufacturer and for more detailed features description, please refer to the manufacturer's specifications or User's Manual.

#### 3.2 Antenna Description of EUT

1. The antenna information is listed as below.

Antenna Net Gain (dBi)	Frequency Range (GHz)	Antenna Type	Connector Type
-0.02	2.4 ~ 2.4835	Printed Inverted F Antenna	none

\* Detail antenna specification please refer to antenna datasheet and/or antenna measurement report.

### 3.3 Channel List

70 channels are provided to this EUT:

Channel	Frequency	Channel	Frequency	Channel	Frequency	Channel	Frequency
1	2405	21	2425	41	2445	61	2465
2	2406	22	2426	42	2446	62	2466
3	2407	23	2427	43	2447	63	2467
4	2408	24	2428	44	2448	64	2468
5	2409	25	2429	45	2449	65	2469
6	2410	26	2430	46	2450	66	2470
7	2411	27	2431	47	2451	67	2471
8	2412	28	2432	48	2452	68	2472
9	2413	29	2433	49	2453	69	2473
10	2414	30	2434	50	2454	70	2474
11	2415	31	2435	51	2455		
12	2416	32	2436	52	2456		
13	2417	33	2437	53	2457		
14	2418	34	2438	54	2458		
15	2419	35	2439	55	2459		
16	2420	36	2440	56	2460		
17	2421	37	2441	57	2461		
18	2422	38	2442	58	2462		
19	2423	39	2443	59	2463		
20	2424	40	2444	60	2464		



### 3.4 Test Mode Applicability and Tested Channel Detail

Pre-Scan:	1. EUT can be used in the following ways: X-axis/ Y-axis/ Z-axis. Pre-scan these ways and find the worst case as a representative test condition. 2. Pre-Scan has been conducted to determine the worst-case mode from all possible combinations between available modulations, data rates and antenna ports (if EUT with antenna diversity architecture).
Worst Case:	1. X-axis/ Y-axis/ Z-axis Worst Condition: X-axis

Test Item	Tested Channel	Modulation	Data Rate
RF Output Power / Power Spectral Density	1, 40, 70	GFSK	2Mb/s
6 dB Bandwidth / Conducted Out of Band Emissions	1, 40, 70	GFSK	2Mb/s
AC Power Conducted Emissions	40	GFSK	2Mb/s
Unwanted Emissions below 1 GHz	40	GFSK	2Mb/s
Unwanted Emissions above 1 GHz	1, 40, 70	GFSK	2Mb/s

### 3.5 Duty Cycle of Test Signal

**GFSK:** Duty cycle =  $0.171 \text{ ms} / 8.004 \text{ ms} \times 100\% = 2.1\%$ , duty factor =  $10 * \log (1/\text{Duty cycle}) = 16.70 \text{ dB}$

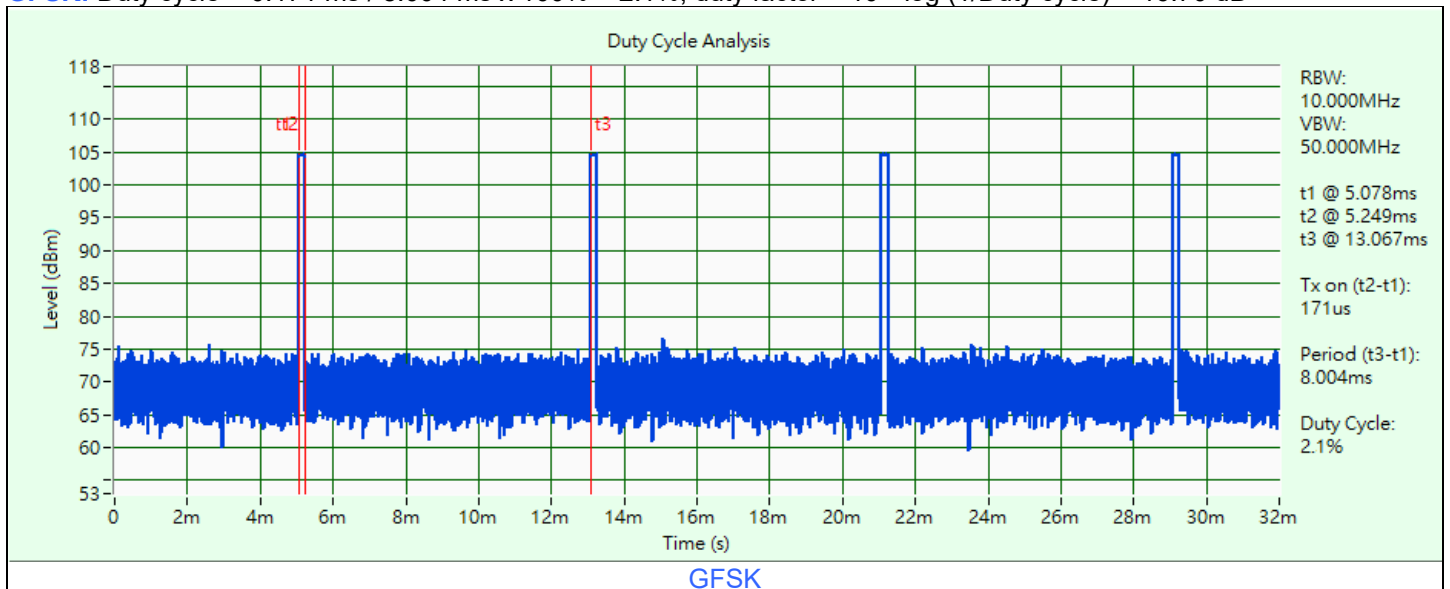

### 3.6 Test Program Used and Operation Descriptions

Controlling software (RF sample with Laptop [press Numlock]) has been activated to set the EUT under transmission condition continuously at specific channel frequency.

Test Item	Operation Description
RF Output Power / Power Spectral Density / 6 dB Bandwidth / Conducted Out of Band Emissions / Unwanted Emissions above 1 GHz	Tx Modulated 2405MHz Tx Modulated 2444MHz Tx Modulated 2474MHz
AC Power Conducted Emissions / Unwanted Emissions below 1 GHz	Tx Modulated 2444MHz

### 3.7 Connection Diagram of EUT and Peripheral Devices

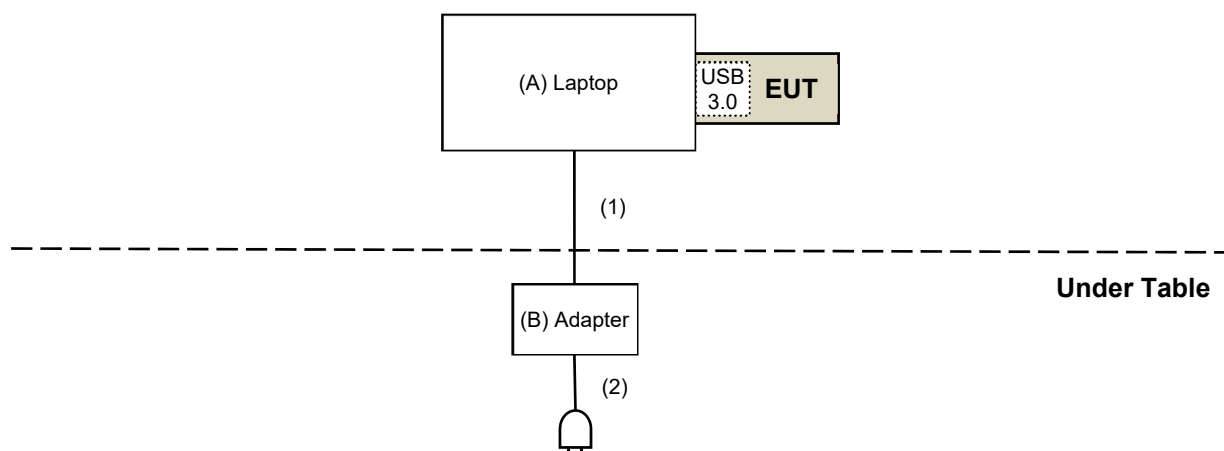

### 3.8 Configuration of Peripheral Devices and Cable Connections

ID	Product	Brand	Model No.	Serial No.	FCC ID	Remarks
A	Laptop	Lenovo	20U5S01X00 L14	PF-1ANPYA	N/A	Provided by Lab
B	Adapter	Lenovo	ADLX45YLC3D	N/A	N/A	Provided by Lab

ID	Cable Descriptions	Qty.	Length (m)	Shielding (Yes/No)	Cores (Qty.)	Remarks
1	DC Cable	1	1.8	No	0	Provided by Lab
2	AC Cable	1	1	No	0	Provided by Lab

## 4 Test Instruments

The calibration interval of the all test instruments are 12 months and the calibrations are traceable to NML/ROC and NIST/USA.

### 4.1 RF Output Power

Description Manufacturer	Model No.	Serial No.	Calibrated Date	Calibrated Until
Power Meter Anritsu	ML2495A	1529002	2023/6/17	2024/6/16
Pulse Power Sensor Anritsu	MA2411B	1726434	2023/6/19	2024/6/18

Notes:

1. The test was performed in Oven room 2.
2. Tested Date: 2023/9/7

### 4.2 Power Spectral Density

Description Manufacturer	Model No.	Serial No.	Calibrated Date	Calibrated Until
MXA Signal Analyzer Keysight	N9020B	MY60112409	2023/2/18	2024/2/17
Software	ADT_RF Test Software V6.6.5.4	N/A	N/A	N/A

Notes:

1. The test was performed in Oven room 2.
2. Tested Date: 2023/9/7

### 4.3 6 dB Bandwidth

Refer to section 4.2 to get information of the instruments.

### 4.4 Conducted Out of Band Emissions

Refer to section 4.2 to get information of the instruments.

#### 4.5 AC Power Conducted Emissions

Description Manufacturer	Model No.	Serial No.	Calibrated Date	Calibrated Until
50 ohm terminal resistance Telegartner	50Ω	3	2022/10/28	2023/10/27
EMI Test Receiver R&S	ESCS 30	847124/029	2022/10/14	2023/10/13
Fixed Attenuator STI	STI02-2200-10	005	2023/7/1	2024/6/30
LISN R&S	ESH3-Z5	848773/004	2022/10/18	2023/10/17
RF Coaxial Cable JYEBAO	5D-FB	COCCAB-001	2023/7/1	2024/6/30
Software BVADT	BVADT_Cond_V7.3.7.4	N/A	N/A	N/A

Notes:

1. The test was performed in Conduction 1
2. Tested Date: 2023/9/27

#### 4.6 Unwanted Emissions below 1 GHz

Description Manufacturer	Model No.	Serial No.	Calibrated Date	Calibrated Until
Antenna Tower & Turn Table Max-Full	MF-7802	MF780208406	N/A	N/A
Bi_Log Antenna Schwarzbeck	VULB 9168	9168-361	2022/10/21	2023/10/20
Fix tool for Boresight antenna tower BV	FBA-01	FBA_SIP01	N/A	N/A
Fixed Attenuator Mini-Circuits	UNAT-5+	PAD-3m-3-01	2023/9/7	2024/9/6
Loop Antenna Electro-Metrics	EM-6879	264	2023/2/21	2024/2/20
MXE EMI Receiver Agilent	N9038A	MY50010156	2023/6/13	2024/6/12
Preamplifier EMCI	EMC330N	980852	2023/2/20	2024/2/19
	EMC001340	980142	2023/5/8	2024/5/7
RF Coaxial Cable JYEBAO	5D-FB	LOOPCAB-001	2022/12/19	2023/12/18
		LOOPCAB-002	2022/12/19	2023/12/18
RF Coaxial Cable PEWC	8D	966-3-2	2023/2/17	2024/2/16
		966-3-3	2023/2/17	2024/2/16
		966-4-1	2023/2/18	2024/2/17
Software	ADT_Radiated_V8.7.08	N/A	N/A	N/A

Notes:

1. The test was performed in 966 Chamber No. 3.
2. Tested Date: 2023/9/27

#### 4.7 Unwanted Emissions above 1 GHz

Description Manufacturer	Model No.	Serial No.	Calibrated Date	Calibrated Until
Antenna Tower & Turn Table Max-Full	MF-7802	MF780208406	N/A	N/A
Fix tool for Boresight antenna tower BV	FBA-01	FBA_SIP01	N/A	N/A
Horn Antenna Schwarzbeck	BBHA 9120D	9120D-406	2022/11/13	2023/11/12
	BBHA 9170	9170-739	2022/11/13	2023/11/12
MXE EMI Receiver Agilent	N9038A	MY50010156	2023/6/13	2024/6/12
Preamplifier EMCI	EMC12630SE	980384	2023/8/9	2024/8/8
	EMC184045SE	980387	2023/8/9	2024/8/8
PXA Signal Analyzer Keysight	N9030B	MY57142938	2023/4/6	2024/4/5
RF Coaxial Cable EMCI	EMC-KM-KM-4000	200214	2023/2/20	2024/2/19
	EMC102-KM-KM-1200	160924	2023/8/9	2024/8/8
	EMC104-SM-SM-1500	180504	2023/3/27	2024/3/26
	EMC104-SM-SM-2000	180601	2023/6/2	2024/6/1
	EMC104-SM-SM-6000	210201	2023/5/8	2024/5/7
Software	ADT_Radiated_V8.7.08	N/A	N/A	N/A

Notes:

1. The test was performed in 966 Chamber No. 3.
2. Tested Date: 2023/9/26 ~ 2023/9/27

## 5 Limits of Test Items

### 5.1 RF Output Power

For systems using digital modulation in the 2400–2483.5 MHz bands: 1 Watt (30 dBm)

### 5.2 Power Spectral Density

The Maximum of Power Spectral Density Measurement is 8 dBm in any 3 kHz.

### 5.3 6 dB Bandwidth

The minimum of 6 dB Bandwidth Measurement is 0.5 MHz.

### 5.4 Conducted Out of Band Emissions

Below 20 dB of the highest emission level of operating band (in 100 kHz Resolution Bandwidth).

### 5.5 AC Power Conducted Emissions

Frequency (MHz)	Conducted Limit (dBuV)	
	Quasi-peak	Average
0.15 - 0.5	66 - 56	56 - 46
0.50 - 5.0	56	46
5.0 - 30.0	60	50

Notes:

1. The lower limit shall apply at the transition frequencies.
2. The limit decreases in line with the logarithm of the frequency in the range of 0.15 to 0.50 MHz.

### 5.6 Unwanted Emissions below 1 GHz

Radiated emissions up to 1 GHz which fall in the restricted bands must comply with the radiated emission limits specified as below table. Other emissions shall be at least 20 dB below the highest level of the desired power:

Frequencies (MHz)	Field Strength (microvolts/meter)	Measurement Distance (meters)
0.009 ~ 0.490	2400/F(kHz)	300
0.490 ~ 1.705	24000/F(kHz)	30
1.705 ~ 30.0	30	30
30 ~ 88	100	3
88 ~ 216	150	3
216 ~ 960	200	3
Above 960	500	3

Notes:

1. The lower limit shall apply at the transition frequencies.
2. Emission level (dBuV/m) = 20 log Emission level (uV/m).

## 5.7 Unwanted Emissions above 1 GHz

Radiated emissions above 1 GHz which fall in the restricted bands must comply with the radiated emission limits specified as below table. Other emissions shall be at least 20 dB below the highest level of the desired power:

Frequencies (MHz)	Field Strength (microvolts/meter)	Measurement Distance (meters)
Above 960	500	3

### Notes:

1. The lower limit shall apply at the transition frequencies.
2. Emission level (dBuV/m) = 20 log Emission level (uV/m).
3. For frequencies above 1000 MHz, the field strength limits are based on average detector, however, the peak field strength of any emission shall not exceed the maximum permitted average limits, specified above by more than 20 dB under any condition of modulation.

## 6 Test Arrangements

### 6.1 RF Output Power

#### 6.1.1 Test Setup

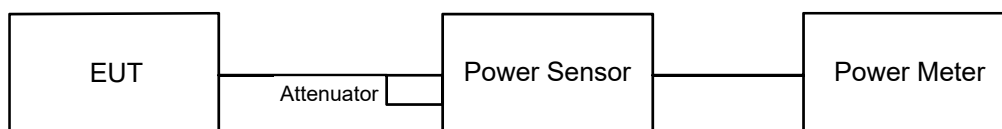

#### 6.1.2 Test Procedure

##### Peak Power:

A peak power sensor was used on the output port of the EUT. A power meter was used to read the response of the peak power sensor. Record the power level.

##### Average Power:

Average power sensor was used to perform output power measurement, trigger and gating function of wide band power meter is enabled to measure max output power of TX on burst. Duty factor is not added to measured value.

### 6.2 Power Spectral Density

#### 6.2.1 Test Setup

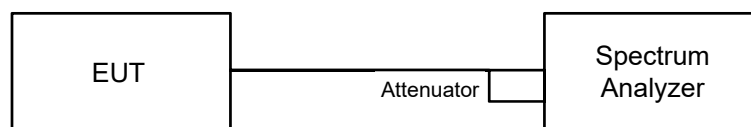

#### 6.2.2 Test Procedure

- a. Set analyzer center frequency to DTS channel center frequency.
- b. Set the span to 1.5 times the DTS bandwidth.
- c. Set the RBW to: 3 kHz.
- d. Set the VBW  $\geq 3 \times$  RBW.
- e. Detector = peak.
- f. Sweep time = auto couple.
- g. Trace mode = max hold.
- h. Allow trace to fully stabilize.
- i. Use the peak marker function to determine the maximum amplitude level within the RBW.



## 6.3 6 dB Bandwidth

### 6.3.1 Test Setup

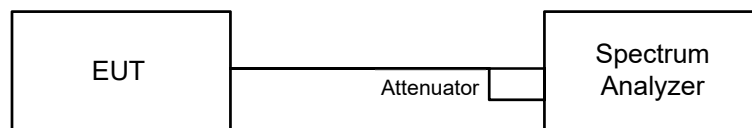

### 6.3.2 Test Procedure

- Set resolution bandwidth (RBW) = 100 kHz.
- Set the video bandwidth (VBW)  $\geq 3 \times$  RBW, Detector = Peak.
- Trace mode = max hold.
- Sweep = auto couple.
- Measure the maximum width of the emission that is constrained by the frequencies associated with the two amplitude points (upper and lower) that are attenuated by 6 dB relative to the maximum level measured in the fundamental emission.

## 6.4 Conducted Out of Band Emissions

### 6.4.1 Test Setup

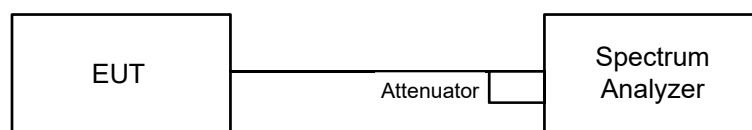

### 6.4.2 Test Procedure

#### MEASUREMENT PROCEDURE REF

- Set the RBW = 100 kHz.
- Set the VBW  $\geq 300$  kHz.
- Detector = peak.
- Sweep time = auto couple.
- Trace mode = max hold.
- Allow trace to fully stabilize.
- Use the peak marker function to determine the maximum power level in any 100 kHz band segment within the fundamental EBW.

#### MEASUREMENT PROCEDURE OOB

- Set RBW = 100 kHz.
- Set VBW  $\geq 300$  kHz.
- Detector = peak.
- Sweep = auto couple.
- Trace Mode = max hold.
- Allow trace to fully stabilize.
- Use the peak marker function to determine the maximum amplitude level.

## 6.5 AC Power Conducted Emissions

### 6.5.1 Test Setup

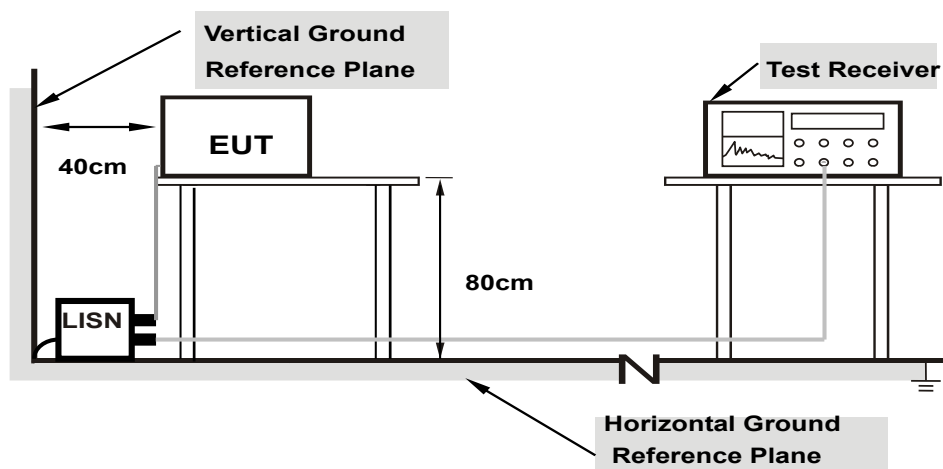

**Note: 1.Support units were connected to second LISN.**

For the actual test configuration, please refer to the attached file (Test Setup Photo).

### 6.5.2 Test Procedure

- The EUT was placed on a 0.8 meter to the top of table and placed 0.4 meters from the conducting wall of the shielded room with EUT being connected to the power mains through a line impedance stabilization network (LISN). Other support units were connected to the power mains through another LISN. The two LISNs provide 50 ohm/ 50 uH of coupling impedance for the measuring instrument.
- Both lines of the power mains connected to the EUT were checked for maximum conducted interference.
- The frequency range from 150 kHz to 30 MHz was searched. Emission levels under (Limit – 20 dB) was not recorded.

Note: The resolution bandwidth and video bandwidth of test receiver is 9 kHz for quasi-peak detection (QP) and average detection (AV) at frequency 0.15 MHz-30 MHz.

## 6.6 Unwanted Emissions below 1 GHz

### 6.6.1 Test Setup

#### For Radiated emission below 30 MHz

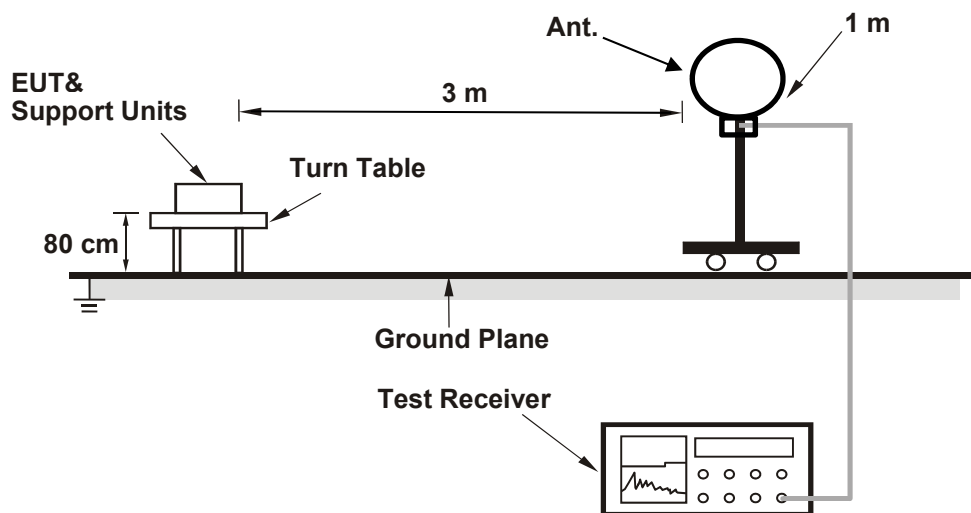

#### For Radiated emission above 30 MHz

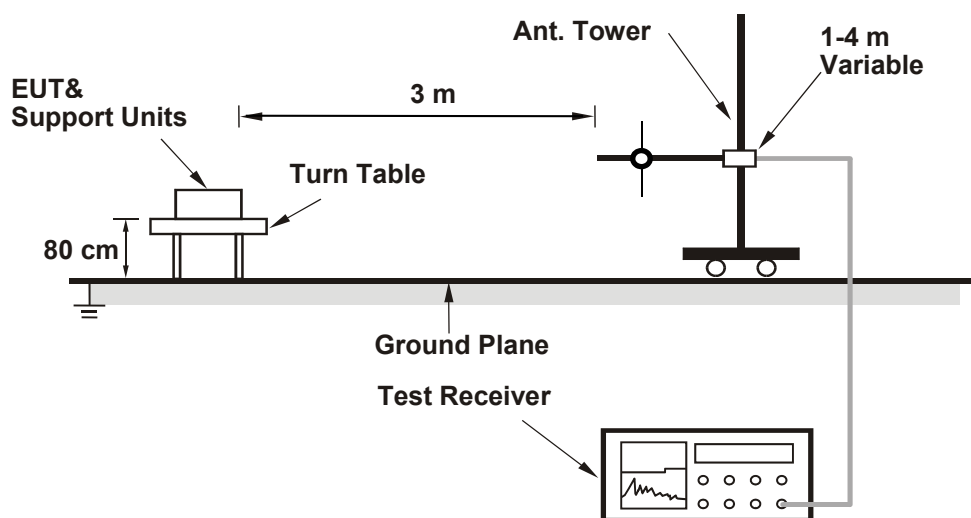

For the actual test configuration, please refer to the attached file (Test Setup Photo).

## 6.6.2 Test Procedure

### For Radiated emission below 30 MHz

- a. The EUT was placed on the top of a rotating table 0.8 meters above the ground at 3 meter chamber room for test. The table was rotated 360 degrees to determine the position of the highest radiation.
- b. The EUT was set 3 meters away from the interference-receiving antenna, which was mounted on the top of a variable-height antenna tower.
- c. Parallel, perpendicular, and ground-parallel orientations of the antenna are set to make the measurement.
- d. For each suspected emission, the EUT was arranged to its worst case and the rotatable table was turned from 0 degrees to 360 degrees to find the maximum reading.
- e. The test-receiver system was set to Quasi-Peak Detect Function and Specified Bandwidth with Maximum Hold Mode, except for the frequency band (9 kHz to 90 kHz and 110 kHz to 490 kHz) set to average detect function and peak detect function.

#### Notes:

1. The resolution bandwidth and video bandwidth of test receiver/spectrum analyzer is 200 Hz at frequency below 150 kHz.
2. The resolution bandwidth and video bandwidth of test receiver/spectrum analyzer is 9 kHz or 10 kHz at frequency (150 kHz to 30 MHz).
3. All modes of operation were investigated and the worst-case emissions are reported.

### For Radiated emission above 30 MHz

- a. The EUT was placed on the top of a rotating table 0.8 meters above the ground at 3 meter chamber room for test. The table was rotated 360 degrees to determine the position of the highest radiation.
- b. The EUT was set 3 meters away from the interference-receiving antenna, which was mounted on the top of a variable-height antenna tower.
- c. The height of antenna is varied from one meter to four meters above the ground to determine the maximum value of the field strength. Both horizontal and vertical polarizations of the antenna are set to make the measurement.
- d. For each suspected emission, the EUT was arranged to its worst case and then the antenna was tuned to heights from 1 meter to 4 meters and the rotatable table was turned from 0 degrees to 360 degrees to find the maximum reading.
- e. The test-receiver system was set to quasi-peak detect function and specified bandwidth with maximum hold mode when the test frequency is below 1 GHz.

#### Notes:

1. The resolution bandwidth and video bandwidth of test receiver/spectrum analyzer is 120 kHz for Quasi-peak detection (QP) at frequency below 1 GHz.
2. All modes of operation were investigated and the worst-case emissions are reported.

## 6.7 Unwanted Emissions above 1 GHz

### 6.7.1 Test Setup

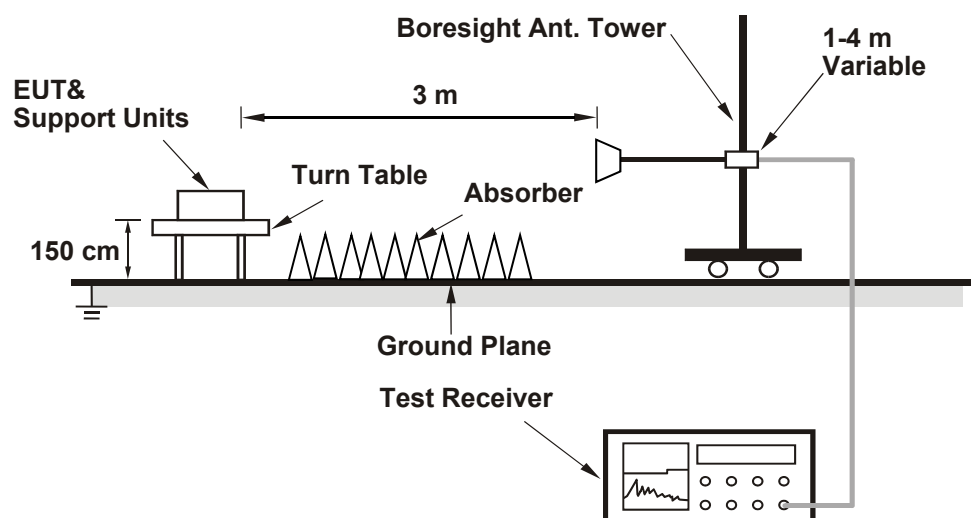

For the actual test configuration, please refer to the attached file (Test Setup Photo).

### 6.7.2 Test Procedure

- The EUT was placed on the top of a rotating table 1.5 meters above the ground at 3 meter chamber room for test. The table was rotated 360 degrees to determine the position of the highest radiation.
- The EUT was set 3 meters away from the interference-receiving antenna, which was mounted on the top of a variable-height antenna tower.
- The height of antenna is varied from one meter to four meters above the ground to determine the maximum value of the field strength. Both horizontal and vertical polarizations of the antenna are set to make the measurement.
- For each suspected emission, the EUT was arranged to its worst case and then the antenna was tuned to heights from 1 meter to 4 meters and the rotatable table was turned from 0 degrees to 360 degrees to find the maximum reading.
- The test-receiver system was set to peak and average detects function and specified bandwidth with maximum hold mode when the test frequency is above 1 GHz. If the peak reading value also meets average limit, measurement with the average detector is unnecessary.

#### Notes:

- The resolution bandwidth of test receiver/spectrum analyzer is 1 MHz and the video bandwidth is 3 MHz for Peak detection (PK) and Average detection (AV) at frequency above 1 GHz.
- For fundamental and harmonic signal measurement, according to KDB 558074 D01 15.247 Meas Guidance v05r02 section 8.1 (c)(3). The spectrum analyzer settings meets the requirements of 11.12.2.4 in ANSI C63.10 for making a Peak measurement, the average value = Peak value + duty cycle correction factor. The duty cycle measurement refer to FCC 47 CFR Part 15C section 15.35 (c). For duty cycle correction factor values, see the Test Signal Duty Cycle section in this report.
- All modes of operation were investigated and the worst-case emissions are reported.

## 7 Test Results of Test Item

### 7.1 RF Output Power

Input Power:	5 Vdc	Environmental Conditions:	25°C, 60% RH	Tested By:	Louis Yang
--------------	-------	---------------------------	--------------	------------	------------

#### For Peak Power

##### GFSK

Chan.	Chan. Freq. (MHz)	Peak Power (mW)	Peak Power (dBm)	Power Limit (dBm)	Test Result
1	2405	6.353	8.03	30	Pass
40	2444	6.368	8.04	30	Pass
70	2474	6.339	8.02	30	Pass

Note: The antenna gain is -0.02 dBi < 6 dBi, so the output power limit shall not be reduced.

#### For Average Power

##### GFSK

Chan.	Chan. Freq. (MHz)	Average Power (mW)	Average Power (dBm)
1	2405	6.281	7.98
40	2444	6.295	7.99
70	2474	6.223	7.94

## 7.2 Power Spectral Density

Input Power:	5 Vdc	Environmental Conditions:	25°C, 60% RH	Tested By:	Louis Yang
--------------	-------	---------------------------	--------------	------------	------------

### GFSK

Chan.	Chan. Freq. (MHz)	PSD (dBm/3kHz)	PSD Limit (dBm/3kHz)	Test Result
1	2405	2.77	8	Pass
40	2444	2.68	8	Pass
70	2474	3.33	8	Pass

Note: The antenna gain is -0.02 dBi < 6 dBi, so the power density limit shall not be reduced.

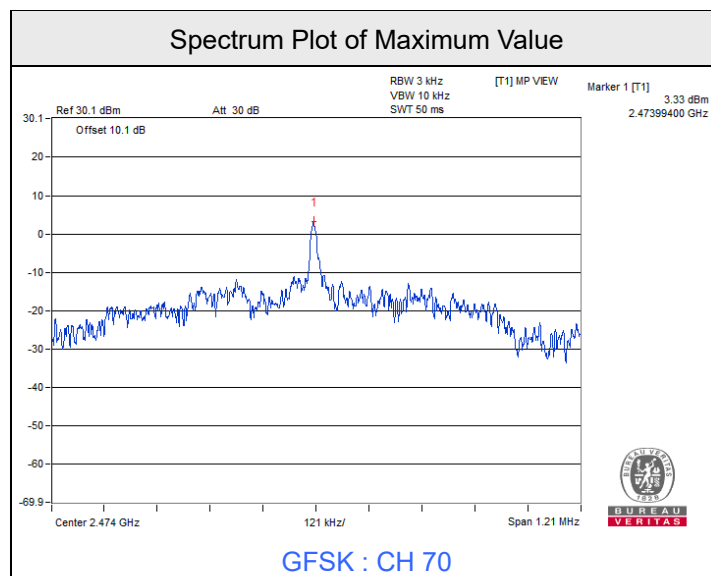

### 7.3 6 dB Bandwidth

Input Power:	5 Vdc	Environmental Conditions:	25°C, 60% RH	Tested By:	Louis Yang
--------------	-------	---------------------------	--------------	------------	------------

#### GFSK

Channel	Frequency (MHz)	6 dB Bandwidth (MHz)	Minimum Limit (MHz)	Test Result
1	2405	0.73	0.5	Pass
40	2444	0.66	0.5	Pass
70	2474	0.81	0.5	Pass

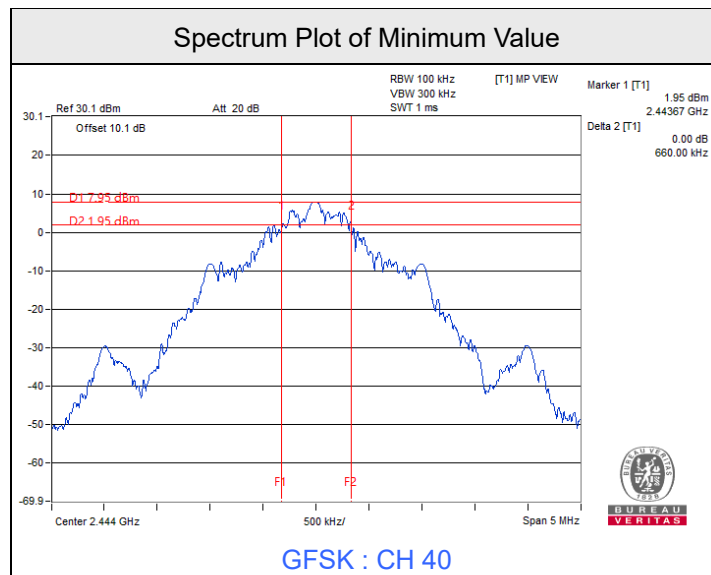



## 7.4 Conducted Out of Band Emissions

Input Power:	5 Vdc	Environmental Conditions:	25°C, 60% RH	Tested By:	Louis Yang
--------------	-------	---------------------------	--------------	------------	------------

### GFSK

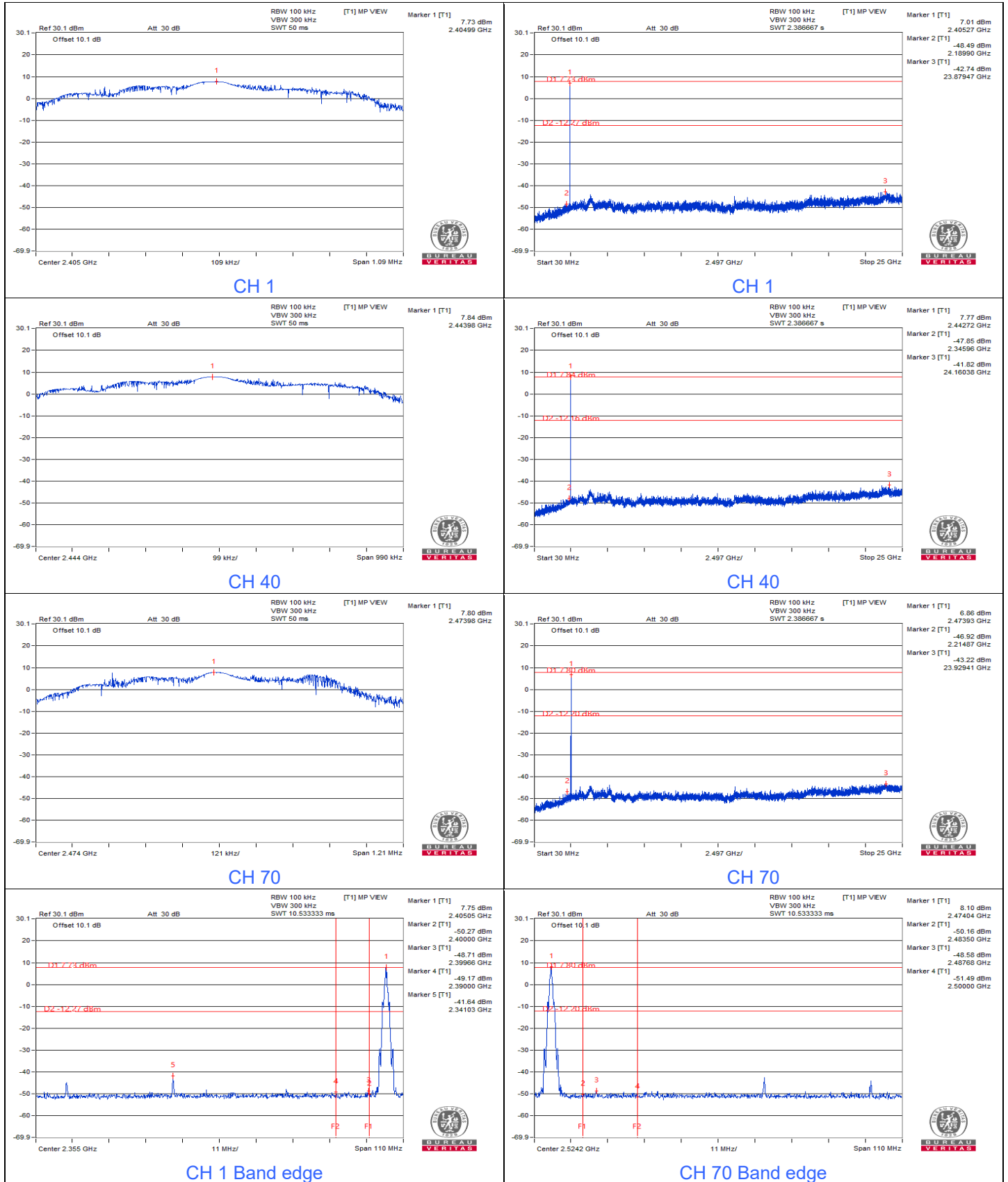

## 7.5 AC Power Conducted Emissions

RF Mode	GFSK	Channel	CH 40 : 2444 MHz
Frequency Range	150 kHz ~ 30 MHz	Detector Function & Resolution Bandwidth	Quasi-Peak (QP) / Average (AV), 9 kHz
Input Power (System)	120 Vac, 60 Hz	Environmental Conditions	23°C, 74% RH

Phase Of Power : Line (L)										
No	Frequency (MHz)	Correction Factor (dB)	Reading Value (dBuV)		Emission Level (dBuV)		Limit (dBuV)		Margin (dB)	
			Q.P.	AV.	Q.P.	AV.	Q.P.	AV.	Q.P.	AV.
1	0.15000	9.95	29.87	7.26	39.82	17.21	66.00	56.00	-26.18	-38.79
2	0.18121	9.94	25.34	3.78	35.28	13.72	64.43	54.43	-29.15	-40.71
3	0.57964	9.96	19.02	6.89	28.98	16.85	56.00	46.00	-27.02	-29.15
4	7.90232	10.35	13.54	2.32	23.89	12.67	60.00	50.00	-36.11	-37.33
5	12.40622	10.59	28.84	16.32	39.43	26.91	60.00	50.00	-20.57	-23.09
6	29.02341	11.30	10.44	5.33	21.74	16.63	60.00	50.00	-38.26	-33.37

### Remarks:

1. Q.P. and AV. are abbreviations of quasi-peak and average individually.
2. The emission levels of other frequencies were very low against the limit.
3. Margin value = Emission level – Limit value
4. Correction factor = Insertion loss + Cable loss
5. Emission Level = Correction Factor + Reading Value

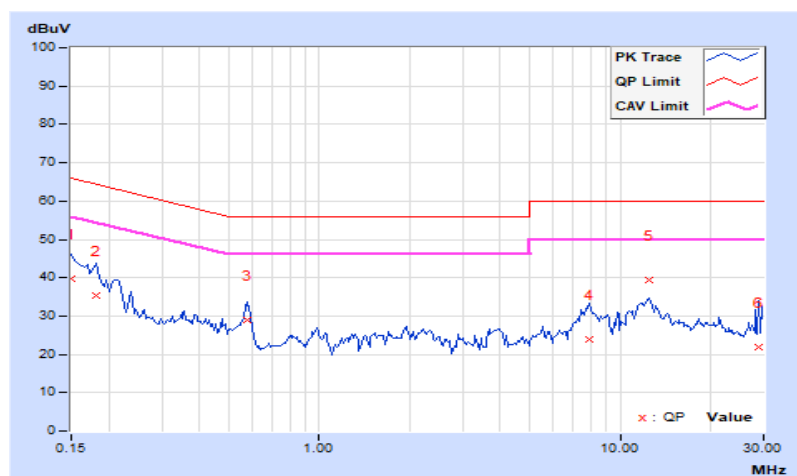

RF Mode	GFSK	Channel	CH 40 : 2444 MHz
Frequency Range	150 kHz ~ 30 MHz	Detector Function & Resolution Bandwidth	Quasi-Peak (QP) / Average (AV), 9 kHz
Input Power (System)	120 Vac, 60 Hz	Environmental Conditions	23°C, 74% RH

Phase Of Power : Neutral (N)										
No	Frequency (MHz)	Correction Factor (dB)	Reading Value (dBuV)		Emission Level (dBuV)		Limit (dBuV)		Margin (dB)	
			Q.P.	AV.	Q.P.	AV.	Q.P.	AV.	Q.P.	AV.
1	0.15390	9.99	39.43	21.05	49.42	31.04	65.79	55.79	-16.37	-24.75
2	0.18123	9.99	35.64	16.02	45.63	26.01	64.43	54.43	-18.80	-28.42
<b>3</b>	<b>0.57577</b>	<b>10.01</b>	<b>28.02</b>	<b>20.56</b>	<b>38.03</b>	<b>30.57</b>	<b>56.00</b>	<b>46.00</b>	<b>-17.97</b>	<b>-15.43</b>
4	0.93514	10.03	17.36	10.19	27.39	20.22	56.00	46.00	-28.61	-25.78
5	4.15232	10.19	15.20	7.42	25.39	17.61	56.00	46.00	-30.61	-28.39
6	12.15233	10.52	23.48	16.85	34.00	27.37	60.00	50.00	-26.00	-22.63

**Remarks:**

1. Q.P. and AV. are abbreviations of quasi-peak and average individually.
2. The emission levels of other frequencies were very low against the limit.
3. Margin value = Emission level – Limit value
4. Correction factor = Insertion loss + Cable loss
5. Emission Level = Correction Factor + Reading Value

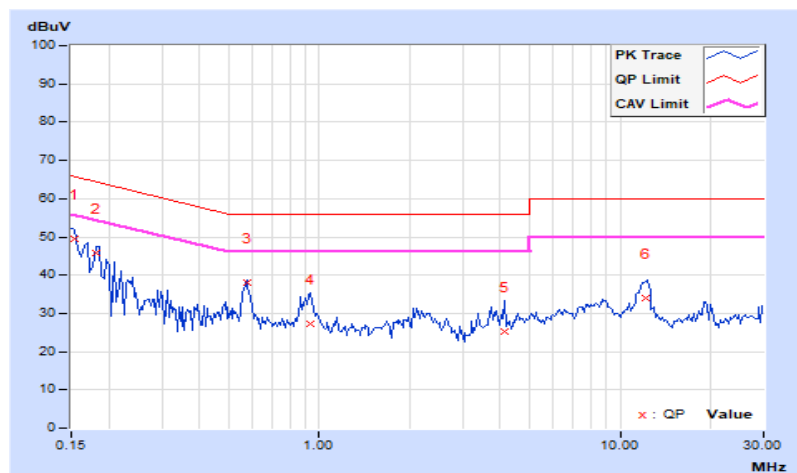

## 7.6 Unwanted Emissions below 1 GHz

<b>RF Mode</b>	GFSK	<b>Channel</b>	CH 40 : 2444 MHz
<b>Frequency Range</b>	30 MHz ~ 1 GHz	<b>Detector Function &amp; Bandwidth</b>	QP: RB=120kHz, DET=Quasi-Peak
<b>Input Power (System)</b>	120 Vac, 60 Hz	<b>Environmental Conditions</b>	25°C, 65% RH
<b>Tested By</b>	Sampson Chen		

### Antenna Polarity & Test Distance : Horizontal at 3 m

No	Frequency (MHz)	Emission Level (dBuV/m)	Limit (dBuV/m)	Margin (dB)	Antenna Height (m)	Table Angle (Degree)	Raw Value (dBuV)	Correction Factor (dB/m)
1	32.57	27.5 QP	40.0	-12.5	2.00 H	360	36.4	-8.9
2	133.06	26.1 QP	43.5	-17.4	1.50 H	250	34.6	-8.5
3	178.64	26.5 QP	43.5	-17.0	2.00 H	170	35.8	-9.3
4	288.83	21.2 QP	46.0	-24.8	1.00 H	360	28.6	-7.4
5	410.08	24.5 QP	46.0	-21.5	2.00 H	350	28.8	-4.3
6	600.85	26.4 QP	46.0	-19.6	3.00 H	355	26.2	0.2

#### Remarks:

1. Emission Level(dBuV/m) = Raw Value(dBuV) + Correction Factor(dB/m)
2. Correction Factor(dB/m) = Antenna Factor(dB/m) + Cable Factor(dB) – Pre-Amplifier Factor(dB)
3. Margin value = Emission Level – Limit value
4. The other emission levels were very low against the limit of frequency range 30 MHz ~ 1 GHz.
5. The frequency range 9 kHz ~ 30 MHz: all emissions are more than 20 dB below the limit, therefore do not be recorded in this report.

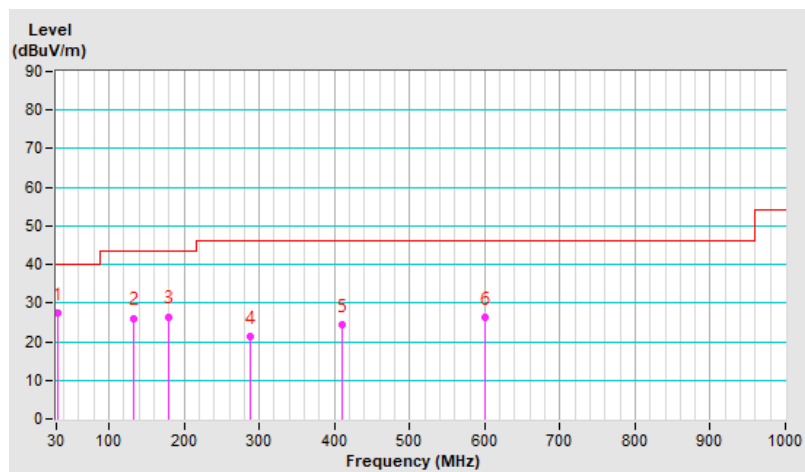

<b>RF Mode</b>	GFSK	<b>Channel</b>	CH 40 : 2444 MHz
<b>Frequency Range</b>	30 MHz ~ 1 GHz	<b>Detector Function &amp; Bandwidth</b>	QP: RB=120kHz, DET=Quasi-Peak
<b>Input Power (System)</b>	120 Vac, 60 Hz	<b>Environmental Conditions</b>	25°C, 65% RH
<b>Tested By</b>	Sampson Chen		

Antenna Polarity & Test Distance : Vertical at 3 m								
No	Frequency (MHz)	Emission Level (dBuV/m)	Limit (dBuV/m)	Margin (dB)	Antenna Height (m)	Table Angle (Degree)	Raw Value (dBuV)	Correction Factor (dB/m)
1	33.61	32.4 QP	40.0	-7.6	1.00 V	240	41.3	-8.9
2	61.23	28.1 QP	40.0	-11.9	1.50 V	70	37.2	-9.1
3	75.64	26.8 QP	40.0	-13.2	1.50 V	342	38.5	-11.7
4	129.67	21.2 QP	43.5	-22.3	1.50 V	10	30.2	-9.0
5	265.94	19.2 QP	46.0	-26.8	1.50 V	310	27.7	-8.5
6	476.67	24.3 QP	46.0	-21.7	2.00 V	83	27.1	-2.8

**Remarks:**

1. Emission Level(dBuV/m) = Raw Value(dBuV) + Correction Factor(dB/m)
2. Correction Factor(dB/m) = Antenna Factor(dB/m) + Cable Factor(dB) – Pre-Amplifier Factor(dB)
3. Margin value = Emission Level – Limit value
4. The other emission levels were very low against the limit of frequency range 30 MHz ~ 1 GHz.
5. The frequency range 9 kHz ~ 30 MHz: all emissions are more than 20 dB below the limit, therefore do not be recorded in this report.

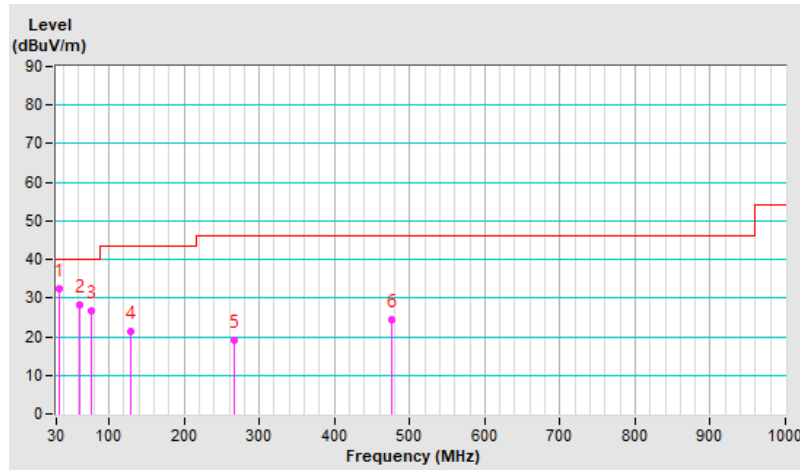

## 7.7 Unwanted Emissions above 1 GHz

<b>RF Mode</b>	GFSK	<b>Channel</b>	CH 1 : 2405 MHz
<b>Frequency Range</b>	1 GHz ~ 25 GHz	<b>Detector Function &amp; Bandwidth</b>	PK: RB=1 MHz, VB=3 MHz, DET=Peak AV: RB=1 MHz, VB=3 MHz, DET=RMS
<b>Input Power (System)</b>	120 Vac, 60 Hz	<b>Environmental Conditions</b>	21°C, 72% RH
<b>Tested By</b>	Sampson Chen		

Antenna Polarity & Test Distance : Horizontal at 3 m								
No	Frequency (MHz)	Emission Level (dBuV/m)	Limit (dBuV/m)	Margin (dB)	Antenna Height (m)	Table Angle (Degree)	Raw Value (dBuV)	Correction Factor (dB/m)
1	2390.00	56.1 PK	74.0	-17.9	1.37 H	216	58.3	-2.2
2	<b>2390.00</b>	<b>46.4 AV</b>	<b>54.0</b>	<b>-7.6</b>	<b>1.37 H</b>	<b>216</b>	<b>48.6</b>	<b>-2.2</b>
3	*2405.00	105.8 PK			1.37 H	216	108.0	-2.2
4	*2405.00	72.4 AV			1.37 H	216	74.6	-2.2
5	4810.00	47.5 PK	74.0	-26.5	1.34 H	158	45.4	2.1
6	4810.00	14.1 AV	54.0	-39.9	1.34 H	158	12.0	2.1

### Remarks:

- Emission Level(dBuV/m) = Raw Value(dBuV) + Correction Factor(dB/m)
- Correction Factor(dB/m) = Antenna Factor(dB/m) + Cable Factor(dB) – Pre-Amplifier Factor(dB)
- Margin value = Emission Level – Limit value
- The other emission levels were very low against the limit.
- " \* " : Fundamental frequency, the limit was restricted at the RF Output Power.
- The average value of fundamental and harmonic frequency is: Average = Peak value + 20 log(Duty cycle) Where the duty cycle correction factor is calculated from following formula:  
 $20 \log(\text{Duty cycle}) = 20 \log(0.171 \text{ ms} / 8.004 \text{ ms}) = -33.4 \text{ dB}$

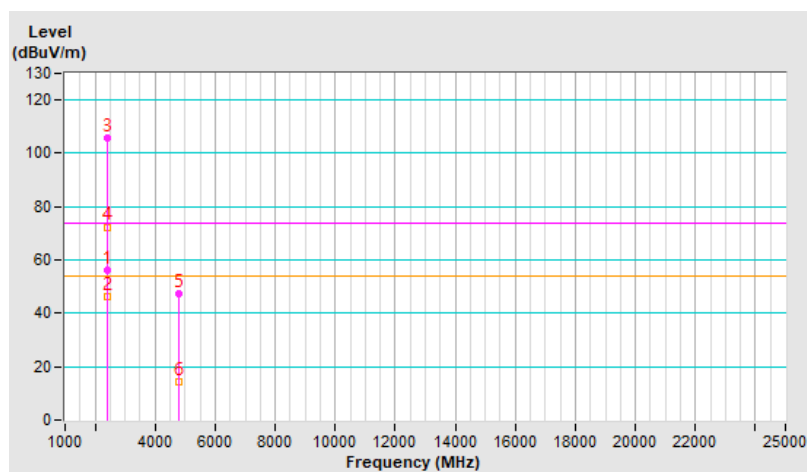

<b>RF Mode</b>	GFSK	<b>Channel</b>	CH 1 : 2405 MHz
<b>Frequency Range</b>	1 GHz ~ 25 GHz	<b>Detector Function &amp; Bandwidth</b>	PK: RB=1 MHz, VB=3 MHz, DET=Peak AV: RB=1 MHz, VB=3 MHz, DET=RMS
<b>Input Power (System)</b>	120 Vac, 60 Hz	<b>Environmental Conditions</b>	21°C, 72% RH
<b>Tested By</b>	Sampson Chen		

Antenna Polarity & Test Distance : Vertical at 3 m								
No	Frequency (MHz)	Emission Level (dBuV/m)	Limit (dBuV/m)	Margin (dB)	Antenna Height (m)	Table Angle (Degree)	Raw Value (dBuV)	Correction Factor (dB/m)
1	2390.00	55.8 PK	74.0	-18.2	2.73 V	219	58.0	-2.2
2	2390.00	46.1 AV	54.0	-7.9	2.73 V	219	48.3	-2.2
3	*2405.00	104.2 PK			2.73 V	219	106.4	-2.2
4	*2405.00	70.8 AV			2.73 V	219	73.0	-2.2
5	4810.00	45.1 PK	74.0	-28.9	1.14 V	201	43.0	2.1
6	4810.00	11.7 AV	54.0	-42.3	1.14 V	201	9.6	2.1

**Remarks:**

1. Emission Level(dBuV/m) = Raw Value(dBuV) + Correction Factor(dB/m)
2. Correction Factor(dB/m) = Antenna Factor(dB/m) + Cable Factor(dB) – Pre-Amplifier Factor(dB)
3. Margin value = Emission Level – Limit value
4. The other emission levels were very low against the limit.
5. " \* " : Fundamental frequency, the limit was restricted at the RF Output Power.
6. The average value of fundamental and harmonic frequency is: Average = Peak value + 20 log(Duty cycle) Where the duty cycle correction factor is calculated from following formula:  
 $20 \log(\text{Duty cycle}) = 20 \log(0.171 \text{ ms} / 8.004 \text{ ms}) = -33.4 \text{ dB}$

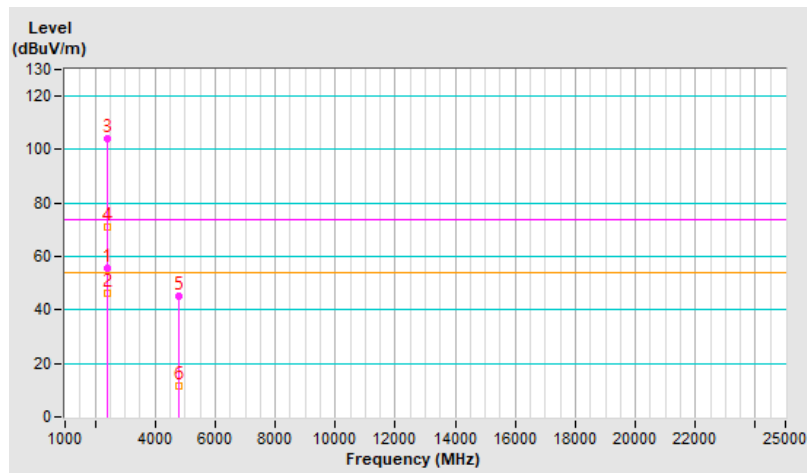

<b>RF Mode</b>	GFSK	<b>Channel</b>	CH 40 : 2444 MHz
<b>Frequency Range</b>	1 GHz ~ 25 GHz	<b>Detector Function &amp; Bandwidth</b>	PK: RB=1 MHz, VB=3 MHz, DET=Peak AV: RB=1 MHz, VB=3 MHz, DET=RMS
<b>Input Power (System)</b>	120 Vac, 60 Hz	<b>Environmental Conditions</b>	21°C, 72% RH
<b>Tested By</b>	Sampson Chen		

Antenna Polarity & Test Distance : Horizontal at 3 m								
No	Frequency (MHz)	Emission Level (dBuV/m)	Limit (dBuV/m)	Margin (dB)	Antenna Height (m)	Table Angle (Degree)	Raw Value (dBuV)	Correction Factor (dB/m)
1	*2444.00	106.1 PK			1.46 H	194	108.2	-2.1
2	*2444.00	72.7 AV			1.46 H	194	74.8	-2.1
3	4888.00	47.7 PK	74.0	-26.3	1.39 H	160	45.8	1.9
4	4888.00	14.3 AV	54.0	-39.7	1.39 H	160	12.4	1.9
5	7332.00	55.8 PK	74.0	-18.2	1.03 H	148	48.1	7.7
6	7332.00	22.4 AV	54.0	-31.6	1.03 H	148	14.7	7.7

**Remarks:**

1. Emission Level(dBuV/m) = Raw Value(dBuV) + Correction Factor(dB/m)
2. Correction Factor(dB/m) = Antenna Factor(dB/m) + Cable Factor(dB) – Pre-Amplifier Factor(dB)
3. Margin value = Emission Level – Limit value
4. The other emission levels were very low against the limit.
5. " \* " : Fundamental frequency, the limit was restricted at the RF Output Power.
6. The average value of fundamental and harmonic frequency is: Average = Peak value + 20 log(Duty cycle) Where the duty cycle correction factor is calculated from following formula:  
 $20 \log(\text{Duty cycle}) = 20 \log(0.171 \text{ ms} / 8.004 \text{ ms}) = -33.4 \text{ dB}$

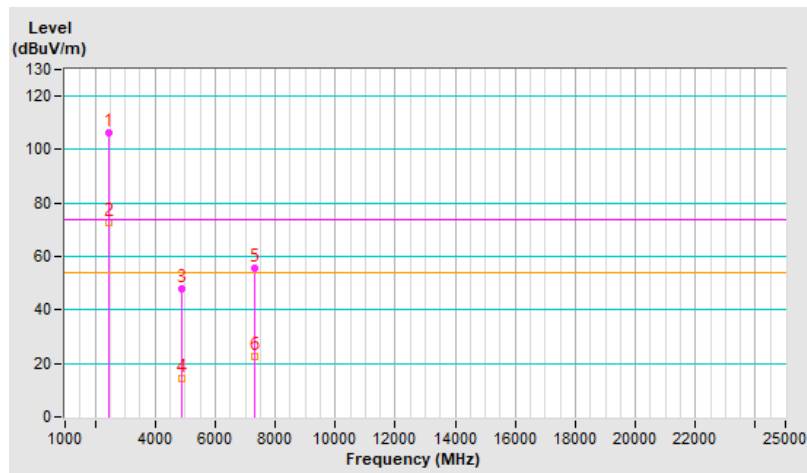



<b>RF Mode</b>	GFSK	<b>Channel</b>	CH 40 : 2444 MHz
<b>Frequency Range</b>	1 GHz ~ 25 GHz	<b>Detector Function &amp; Bandwidth</b>	PK: RB=1 MHz, VB=3 MHz, DET=Peak AV: RB=1 MHz, VB=3 MHz, DET=RMS
<b>Input Power (System)</b>	120 Vac, 60 Hz	<b>Environmental Conditions</b>	21°C, 72% RH
<b>Tested By</b>	Sampson Chen		

Antenna Polarity & Test Distance : Vertical at 3 m								
No	Frequency (MHz)	Emission Level (dBuV/m)	Limit (dBuV/m)	Margin (dB)	Antenna Height (m)	Table Angle (Degree)	Raw Value (dBuV)	Correction Factor (dB/m)
1	*2444.00	102.8 PK			2.50 V	222	104.9	-2.1
2	*2444.00	69.4 AV			2.50 V	222	71.5	-2.1
3	4888.00	45.3 PK	74.0	-28.7	1.18 V	190	43.4	1.9
4	4888.00	11.9 AV	54.0	-42.1	1.18 V	190	10.0	1.9
5	7332.00	54.5 PK	74.0	-19.5	1.66 V	201	46.8	7.7
6	7332.00	21.1 AV	54.0	-32.9	1.66 V	201	13.4	7.7

**Remarks:**

1. Emission Level(dBuV/m) = Raw Value(dBuV) + Correction Factor(dB/m)
2. Correction Factor(dB/m) = Antenna Factor(dB/m) + Cable Factor(dB) – Pre-Amplifier Factor(dB)
3. Margin value = Emission Level – Limit value
4. The other emission levels were very low against the limit.
5. " \* " : Fundamental frequency, the limit was restricted at the RF Output Power.
6. The average value of fundamental and harmonic frequency is: Average = Peak value + 20 log(Duty cycle) Where the duty cycle correction factor is calculated from following formula:  
 $20 \log(\text{Duty cycle}) = 20 \log(0.171 \text{ ms} / 8.004 \text{ ms}) = -33.4 \text{ dB}$

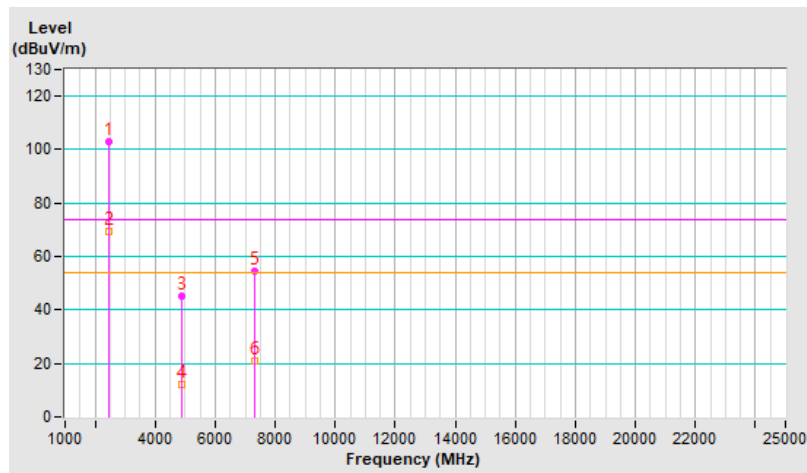

<b>RF Mode</b>	GFSK	<b>Channel</b>	CH 70 : 2474 MHz
<b>Frequency Range</b>	1 GHz ~ 25 GHz	<b>Detector Function &amp; Bandwidth</b>	PK: RB=1 MHz, VB=3 MHz, DET=Peak AV: RB=1 MHz, VB=3 MHz, DET=RMS
<b>Input Power (System)</b>	120 Vac, 60 Hz	<b>Environmental Conditions</b>	21°C, 72% RH
<b>Tested By</b>	Sampson Chen		

Antenna Polarity & Test Distance : Horizontal at 3 m								
No	Frequency (MHz)	Emission Level (dBuV/m)	Limit (dBuV/m)	Margin (dB)	Antenna Height (m)	Table Angle (Degree)	Raw Value (dBuV)	Correction Factor (dB/m)
1	*2474.00	104.3 PK			1.54 H	240	106.4	-2.1
2	*2474.00	70.9 AV			1.54 H	240	73.0	-2.1
3	2483.50	55.1 PK	74.0	-18.9	1.54 H	240	57.3	-2.2
4	2483.50	46.1 AV	54.0	-7.9	1.54 H	240	48.3	-2.2
5	4948.00	41.2 PK	74.0	-32.8	2.74 H	67	39.2	2.0
6	4948.00	7.8 AV	54.0	-46.2	2.74 H	67	5.8	2.0
7	7422.00	55.9 PK	74.0	-18.1	1.72 H	274	47.8	8.1
8	7422.00	22.5 AV	54.0	-31.5	1.72 H	274	14.4	8.1

**Remarks:**

1. Emission Level(dBuV/m) = Raw Value(dBuV) + Correction Factor(dB/m)
2. Correction Factor(dB/m) = Antenna Factor(dB/m) + Cable Factor(dB) – Pre-Amplifier Factor(dB)
3. Margin value = Emission Level – Limit value
4. The other emission levels were very low against the limit.
5. " \* " : Fundamental frequency, the limit was restricted at the RF Output Power.
6. The average value of fundamental and harmonic frequency is: Average = Peak value + 20 log(Duty cycle) Where the duty cycle correction factor is calculated from following formula:  
 $20 \log(\text{Duty cycle}) = 20 \log(0.171 \text{ ms} / 8.004 \text{ ms}) = -33.4 \text{ dB}$

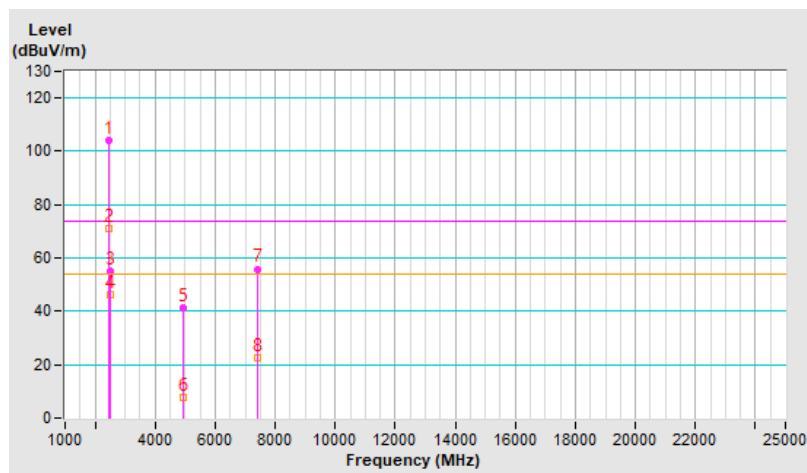



<b>RF Mode</b>	GFSK	<b>Channel</b>	CH 70 : 2474 MHz
<b>Frequency Range</b>	1 GHz ~ 25 GHz	<b>Detector Function &amp; Bandwidth</b>	PK: RB=1 MHz, VB=3 MHz, DET=Peak AV: RB=1 MHz, VB=3 MHz, DET=RMS
<b>Input Power (System)</b>	120 Vac, 60 Hz	<b>Environmental Conditions</b>	21°C, 72% RH
<b>Tested By</b>	Sampson Chen		

Antenna Polarity & Test Distance : Vertical at 3 m								
No	Frequency (MHz)	Emission Level (dBUV/m)	Limit (dBUV/m)	Margin (dB)	Antenna Height (m)	Table Angle (Degree)	Raw Value (dBUV)	Correction Factor (dB/m)
1	*2474.00	101.8 PK			2.20 V	270	103.9	-2.1
2	*2474.00	68.4 AV			2.20 V	270	70.5	-2.1
3	2483.50	54.8 PK	74.0	-19.2	2.20 V	270	57.0	-2.2
4	2483.50	46.0 AV	54.0	-8.0	2.20 V	270	48.2	-2.2
5	4948.00	41.5 PK	74.0	-32.5	1.45 V	217	39.5	2.0
6	4948.00	8.1 AV	54.0	-45.9	1.45 V	217	6.1	2.0
7	7422.00	55.3 PK	74.0	-18.7	1.02 V	218	47.2	8.1
8	7422.00	21.9 AV	54.0	-32.1	1.02 V	218	13.8	8.1

**Remarks:**

1. Emission Level(dBUV/m) = Raw Value(dBuV) + Correction Factor(dB/m)
2. Correction Factor(dB/m) = Antenna Factor(dB/m) + Cable Factor(dB) – Pre-Amplifier Factor(dB)
3. Margin value = Emission Level – Limit value
4. The other emission levels were very low against the limit.
5. " \* " : Fundamental frequency, the limit was restricted at the RF Output Power.
6. The average value of fundamental and harmonic frequency is: Average = Peak value + 20 log(Duty cycle) Where the duty cycle correction factor is calculated from following formula:  
 $20 \log(\text{Duty cycle}) = 20 \log(0.171 \text{ ms} / 8.004 \text{ ms}) = -33.4 \text{ dB}$

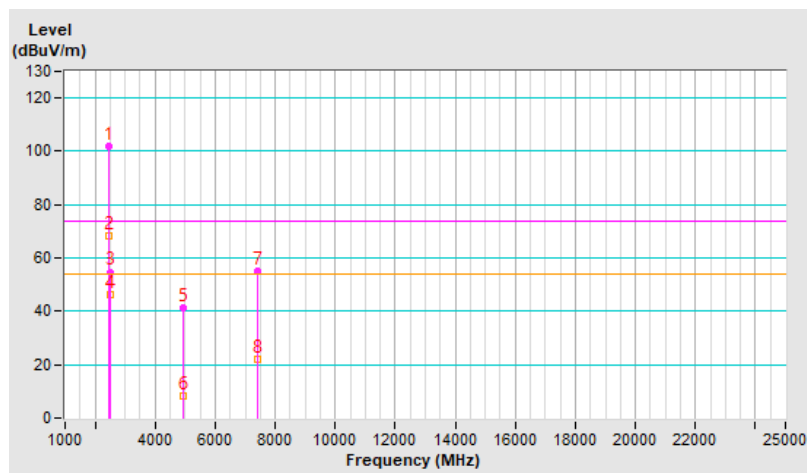

### Plot of Band Edge

Frequency Range	2.31 GHz ~ 2.5 GHz	Detector Function & Bandwidth	PK: RB=1 MHz, VB=3 MHz, DET=Peak AV: RB=1 MHz, VB=3 MHz, DET=RMS
-----------------	--------------------	-------------------------------	---

#### GFSK Channel 1

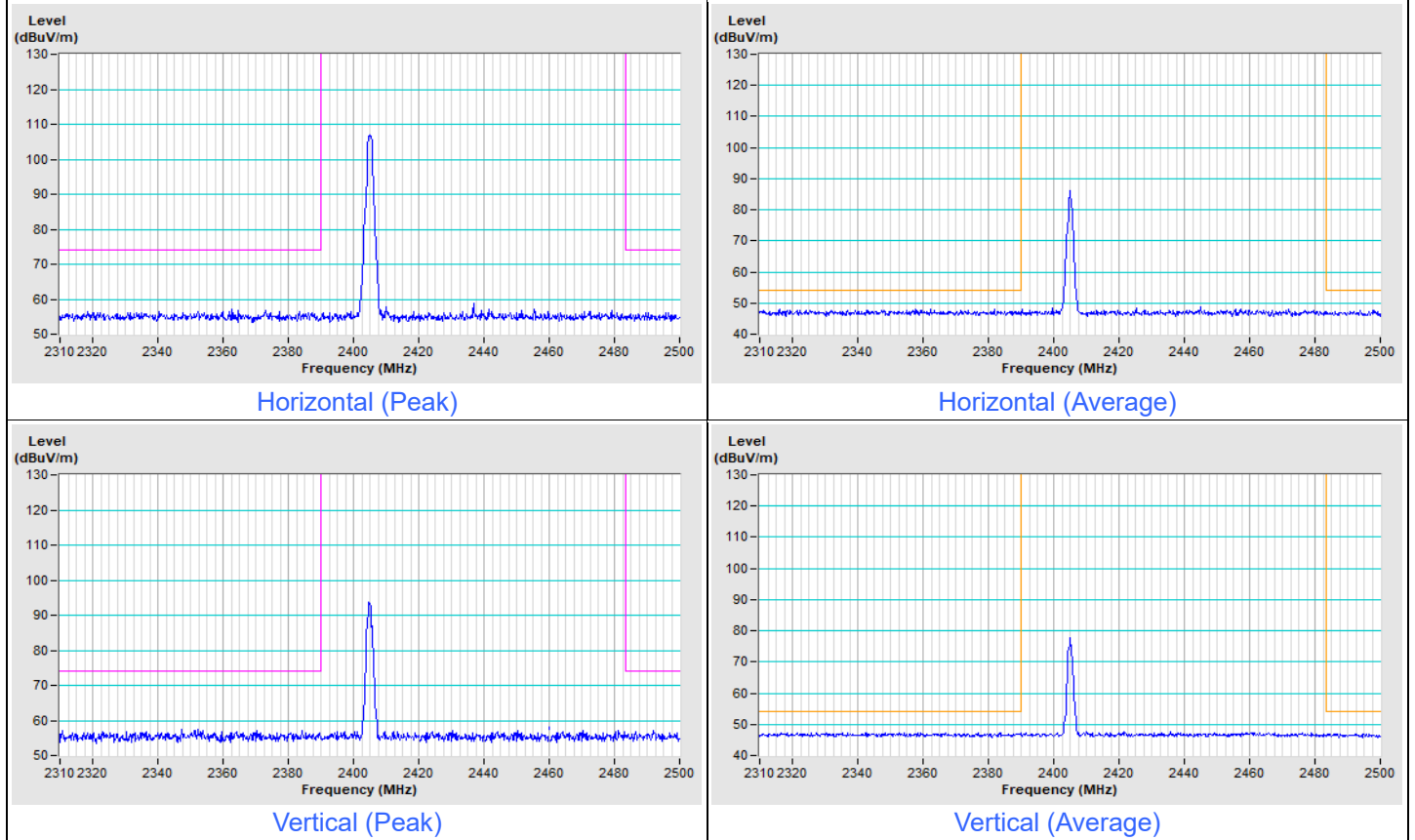

### GFSK Channel 70

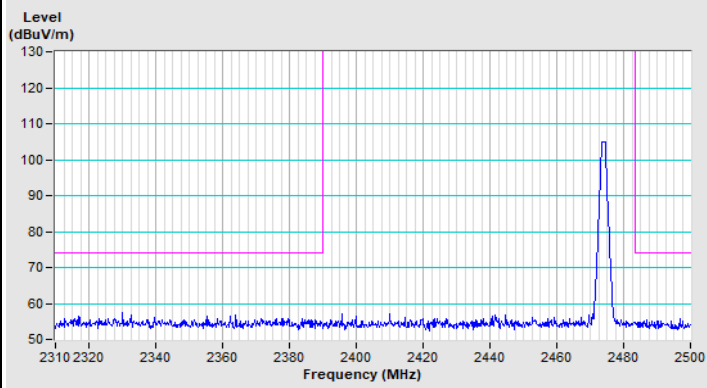

Horizontal (Peak)

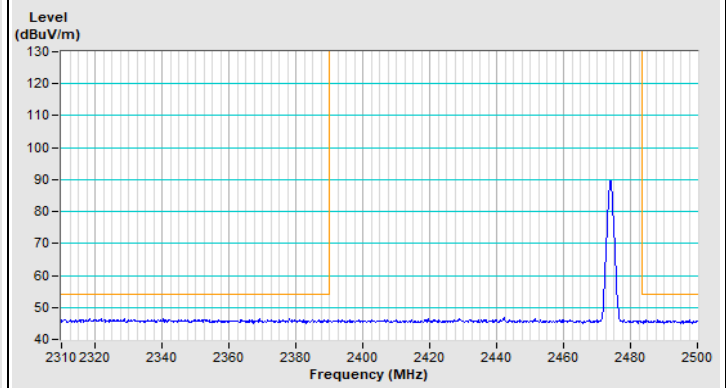

Horizontal (Average)

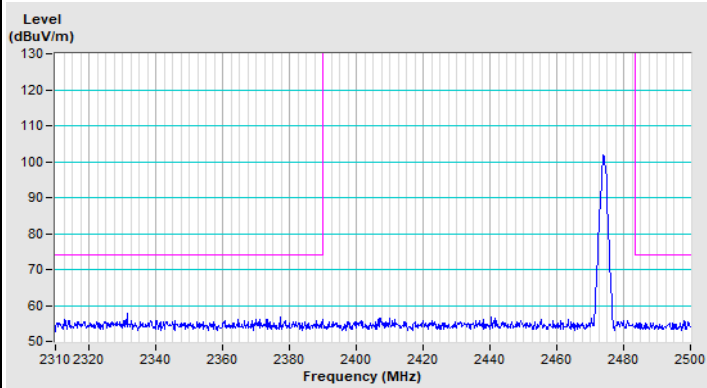

Vertical (Peak)

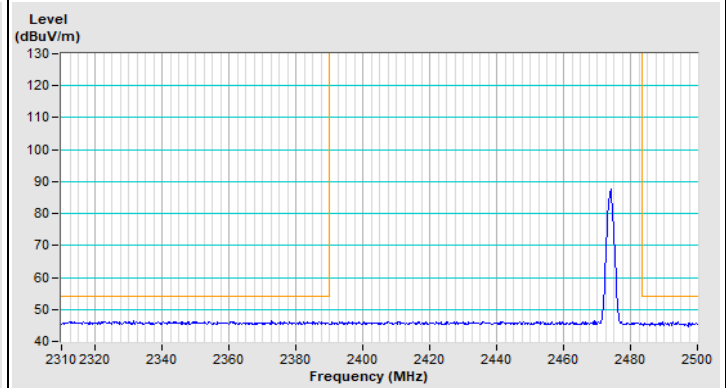

Vertical (Average)

## 8 Pictures of Test Arrangements

Please refer to the attached file (Test Setup Photo)

## 9 Information of the Testing Laboratories

We, Bureau Veritas Consumer Products Services (H.K.) Ltd., Taoyuan Branch, were founded in 1988 to provide our best service in EMC, Radio, Telecom and Safety consultation. Our laboratories are FCC recognized accredited test firms and accredited according to ISO/IEC 17025.

If you have any comments, please feel free to contact us at the following:

**Lin Kou EMC/RF Lab**

Tel: 886-2-26052180

Fax: 886-2-26051924

**Hsin Chu EMC/RF/Telecom Lab**

Tel: 886-3-6668565

Fax: 886-3-6668323

**Hwa Ya EMC/RF/Safety Lab**

Tel: 886-3-3183232

Fax: 886-3-3270892

**Email:** [service.adt@bureauveritas.com](mailto:service.adt@bureauveritas.com)

**Web Site:** <http://ee.bureauveritas.com.tw>

The address and road map of all our labs can be found in our web site also.

--- END ---