

TEST REPORT

CERTIFICATE OF CONFORMITY

Standard: 47 CFR FCC Part 15, Subpart C (Section 15.247)
ANSI C63.10-2013

Report No.: RFBDKG-WTW-P21113001

FCC ID: JNZA00172

Model No.: A00172

Received Date: 2022/1/6

Test Date: 2022/1/20 ~ 2022/2/8

Issued Date: 2022/3/22

Applicant: Logitech Far East Ltd

Address: 7700 Gateway Boulevard Newark California United States

Issued By: Bureau Veritas Consumer Products Services (H.K.) Ltd., Taoyuan Branch
Hsin Chu Laboratory

Lab Address: E-2, No.1, Li Hsin 1st Road, Hsinchu Science Park, Hsinchu City 300, Taiwan

Test Location: E-2, No.1, Li Hsin 1st Road, Hsinchu Science Park, Hsinchu City 300, Taiwan

FCC Registration / 723255 / TW2022

Designation Number:

Approved by: _____



Date: _____

2022/3/22

Clark Lin / Technical Manager

This test report consists of 52 pages in total. It may be duplicated completely for legal use with the approval of the applicant. It should not be reproduced except in full, without the written approval of our laboratory. The test results in the report only apply to the tested sample. The test results in this report are traceable to the national or international standards.



Prepared by : Cherry Chuo / Specialist

This report is for your exclusive use. Any copying or replication of this report to or for any other person or entity, or use of our name or trademark, is permitted only with our prior written permission. This report sets forth our findings solely with respect to the test samples identified herein. The results set forth in this report are not indicative or representative of the quality or characteristics of the lot from which a test sample was taken or any similar or identical product unless specifically and expressly noted. Our report includes all of the tests requested by you and the results thereof based upon the information that you provided to us. You have 60 days from date of issuance of this report to notify us of any material error or omission caused by our negligence, provided, however, that such notice shall be in writing and shall specifically address the issue you wish to raise. A failure to raise such issue within the prescribed time shall constitute your unqualified acceptance of the completeness of this report, the tests conducted and the correctness of the report contents. Unless specific mention, the uncertainty of measurement has been explicitly taken into account to declare the compliance or non-compliance to the specification.

Table of Contents

Release Control Record	4
1 Certificate	5
2 Summary of Test Results	6
2.1 Measurement Uncertainty	6
2.2 Supplementary Information	6
3 General Information	7
3.1 General Description	7
3.2 Antenna Description of EUT	7
3.3 Channel List	8
3.4 Test Mode Applicability and Tested Channel Detail	9
3.5 Duty Cycle of Test Signal	10
3.6 Test Program Used and Operation Descriptions	11
3.7 Connection Diagram of EUT and Peripheral Devices	11
3.8 Configuration of Peripheral Devices and Cable Connections	12
4 Test Instruments	13
4.1 RF Output Power	13
4.2 Number of Hopping Frequency Used	13
4.3 Dwell Time on Each Channel	13
4.4 Hopping Channel Separation	13
4.5 20dB Bandwidth	13
4.6 Conducted Out of Band Emissions	13
4.7 AC Power Conducted Emissions	14
4.8 Unwanted Emissions below 1 GHz	14
4.9 Unwanted Emissions above 1 GHz	15
5 Limits of Test Items	16
5.1 RF Output Power	16
5.2 Number of Hopping Frequency Used	16
5.3 Dwell Time on Each Channel	16
5.4 Hopping Channel Separation	16
5.5 20dB Bandwidth	16
5.6 Conducted Out of Band Emissions	16
5.7 AC Power Conducted Emissions	16
5.8 Unwanted Emissions below 1 GHz	17
5.9 Unwanted Emissions above 1 GHz	17
6 Test Arrangements	18
6.1 RF Output Power	18
6.1.1 Test Setup	18
6.1.2 Test Procedure	18
6.2 Number of Hopping Frequency Used	18
6.2.1 Test Setup	18
6.2.2 Test Procedure	18
6.3 Dwell Time on Each Channel	19
6.3.1 Test Setup	19
6.3.2 Test Procedure	19
6.4 Hopping Channel Separation	19
6.4.1 Test Setup	19
6.4.2 Test Procedure	19
6.5 20dB Bandwidth	20
6.5.1 Test Setup	20
6.5.2 Test Procedure	20
6.6 Conducted Out of Band Emissions	20
6.6.1 Test Setup	20
6.6.2 Test Procedure	20
6.7 AC Power Conducted Emissions	21



6.7.1	Test Setup	21
6.7.2	Test Procedure.....	21
6.8	Unwanted Emissions below 1 GHz	22
6.8.1	Test Setup	22
6.8.2	Test Procedure.....	23
6.9	Unwanted Emissions above 1 GHz.....	24
6.9.1	Test Setup	24
6.9.2	Test Procedure.....	24
7	Test Results of Test Item	25
7.1	RF Output Power.....	25
7.2	Number of Hopping Frequency Used.....	26
7.3	Dwell Time on Each Channel	27
7.4	Hopping Channel Separation	29
7.5	20dB Bandwidth	30
7.6	Conducted Out of Band Emissions	31
7.7	AC Power Conducted Emissions	33
7.8	Unwanted Emissions below 1 GHz	35
7.9	Unwanted Emissions above 1 GHz.....	37
8	Pictures of Test Arrangements	51
9	Information of the Testing Laboratories	52



Release Control Record

Issue No.	Description	Date Issued
RFBDKG-WTW-P21113001	Original release.	2022/3/22

1 Certificate

Product: wireless dongle

Brand: Logitech

Test Model: A00172

Sample Status: Engineering sample

Applicant: Logitech Far East Ltd

Test Date: 2022/1/20 ~ 2022/2/8

Standard: 47 CFR FCC Part 15, Subpart C (Section 15.247)
ANSI C63.10-2013

Measurement procedure: KDB 558074 D01 15.247 Meas Guidance v05r02

The above equipment has been tested by **Bureau Veritas Consumer Products Services (H.K.) Ltd., Taoyuan Branch**, and found compliance with the requirement of the above standards. The test record, data evaluation & Equipment Under Test (EUT) configurations represented herein are true and accurate accounts of the measurements of the sample's RF characteristics under the conditions specified in this report.

2 Summary of Test Results

47 CFR FCC Part 15, Subpart C (Section 15.247)			
Standard / Clause	Test Item	Result	Remark
15.247(b)	RF Output Power	Pass	Meet the requirement of limit.
15.247(a)(1) (iii)	Number of Hopping Frequency Used	Pass	Meet the requirement of limit.
15.247(a)(1) (iii)	Dwell Time on Each Channel	Pass	Meet the requirement of limit.
15.247(a)(1)	Hopping Channel Separation	Pass	Meet the requirement of limit.
15.247(a)(1)	20dB Bandwidth	-	Refer to Note 1
15.247(a)(1)	Spectrum Bandwidth of a Frequency Hopping Sequence Spread Spectrum System	Pass	Meet the requirement of limit.
15.247(d)	Conducted Out of Band Emissions	Pass	Meet the requirement of limit.
15.207	AC Power Conducted Emissions	Pass	Minimum passing margin is -15.87 dB at 0.43516 MHz
15.205 / 15.209 / 15.247(d)	Unwanted Emissions below 1 GHz	Pass	Minimum passing margin is -12.6 dB at 58.86 MHz
15.205 / 15.209 / 15.247(d)	Unwanted Emissions above 1 GHz	Pass	Minimum passing margin is -7.8 dB at 2483.50 MHz
15.203	Antenna Requirement	Pass	No antenna connector is used.

Notes:

1. If the Frequency Hopping System operating in 2400-2483.5MHz band and the output power less than 125mW. The hopping channel carrier frequencies separated by a minimum of 25kHz or two-thirds of the 20dB bandwidth of hopping channel whichever is greater.
2. Determining compliance based on the results of the compliance measurement, not taking into account measurement instrumentation uncertainty.

2.1 Measurement Uncertainty

Where relevant, the following measurement uncertainty levels have been estimated for tests performed on the EUT as specified in CISPR 16-4-2:

Measurement	Specification	Expanded Uncertainty (k=2) (±)
Conducted Out of Band Emissions	9 kHz ~ 40 GHz	2.5 dB
AC Power Conducted Emissions	150 kHz ~ 30 MHz	1.9 dB
Unwanted Emissions below 1 GHz	30 MHz ~ 1 GHz	5.1 dB
Unwanted Emissions above 1 GHz	1 GHz ~ 18 GHz	5.1 dB
	18 GHz ~ 40 GHz	5.3 dB

The other instruments specified are routine verified to remain within the calibrated levels, no measurement uncertainty is required to be calculated.

2.2 Supplementary Information

There is not any deviation from the test standards for the test method, and no modifications required for compliance.

3 General Information

3.1 General Description

Product	wireless dongle
Brand	Logitech
Test Model	A00172
Status of EUT	Engineering sample
Power Supply Rating	5 Vdc from USB interface
Modulation Type	GFSK, $\pi/4$ -DQPSK, 8DPSK
Modulation Technology	FHSS
Transfer Rate	Up to 3 Mbps
Operating Frequency	2402 ~ 2480 MHz
Number of Channel	79
Output Power	19.634 mW

Note:

1. The EUT may have a lot of colors for marketing requirement.
2. The above EUT information is declared by manufacturer and for more detailed features description, please refers to the manufacturer's specifications or user's manual.

3.2 Antenna Description of EUT

1. The antenna information is listed as below.

Brand	Model	Antenna Net Gain (dBi)	Frequency Range (GHz)	Antenna Type	Connector Type
Logitech	A00172	-3.01	2.4~2.4835	Metal	None

*The above Antenna information is declared by manufacturer and for more detailed features description, please refer to the manufacturer's specifications, the laboratory shall not be held responsible.

3.3 Channel List

79 channels are provided for BT-EDR:

Channel	Frequency (MHz)	Channel	Frequency (MHz)	Channel	Frequency (MHz)	Channel	Frequency (MHz)
0	2402	20	2422	40	2442	60	2462
1	2403	21	2423	41	2443	61	2463
2	2404	22	2424	42	2444	62	2464
3	2405	23	2425	43	2445	63	2465
4	2406	24	2426	44	2446	64	2466
5	2407	25	2427	45	2447	65	2467
6	2408	26	2428	46	2448	66	2468
7	2409	27	2429	47	2449	67	2469
8	2410	28	2430	48	2450	68	2470
9	2411	29	2431	49	2451	69	2471
10	2412	30	2432	50	2452	70	2472
11	2413	31	2433	51	2453	71	2473
12	2414	32	2434	52	2454	72	2474
13	2415	33	2435	53	2455	73	2475
14	2416	34	2436	54	2456	74	2476
15	2417	35	2437	55	2457	75	2477
16	2418	36	2438	56	2458	76	2478
17	2419	37	2439	57	2459	77	2479
18	2420	38	2440	58	2460	78	2480
19	2421	39	2441	59	2461		

3.4 Test Mode Applicability and Tested Channel Detail

Pre-Scan:	1. EUT can be used in the following ways: X/ Y/ Z. Pre-scan in these ways and find the worst case as a representative test condition.
Worst Case:	X-plane

Following channel(s) was (were) selected for the final test as listed below:

Test Item	EUT Configure Mode	Tested Channel	Modulation	Data Rate Parameter
AC Power Conducted Emissions	A	39	GFSK	DH5
Unwanted Emissions below 1 GHz	A	39	GFSK	DH5
Unwanted Emissions above 1 GHz	A	0, 39, 78	GFSK	DH5
		0, 39, 78	8DPSK	3DH5
RF Output Power \ Hopping Channel Separation \ 20dB Bandwidth	B	0, 39, 78	GFSK	DH5
		0, 39, 78	8DPSK	3DH5
Number of Hopping Frequency Used \ Conducted Out of Band Emissions	B	Hopping	GFSK	DH5
		Hopping	8DPSK	3DH5
Dwell Time on Each Channel	B	Hopping	GFSK	DH1/ DH3/ DH5
		Hopping	8DPSK	3DH1/ 3DH3/ 3DH5
EUT Configure Mode:	A	Radiated measurement with laptop mode		
	B	Antenna Port Conducted measurement		

3.5 Duty Cycle of Test Signal

GFSK: Duty cycle = $3.188 \text{ ms} / 100 \text{ ms} = 0.03188$

8DPSK: Duty cycle = $3.333 \text{ ms} / 100 \text{ ms} = 0.03333$

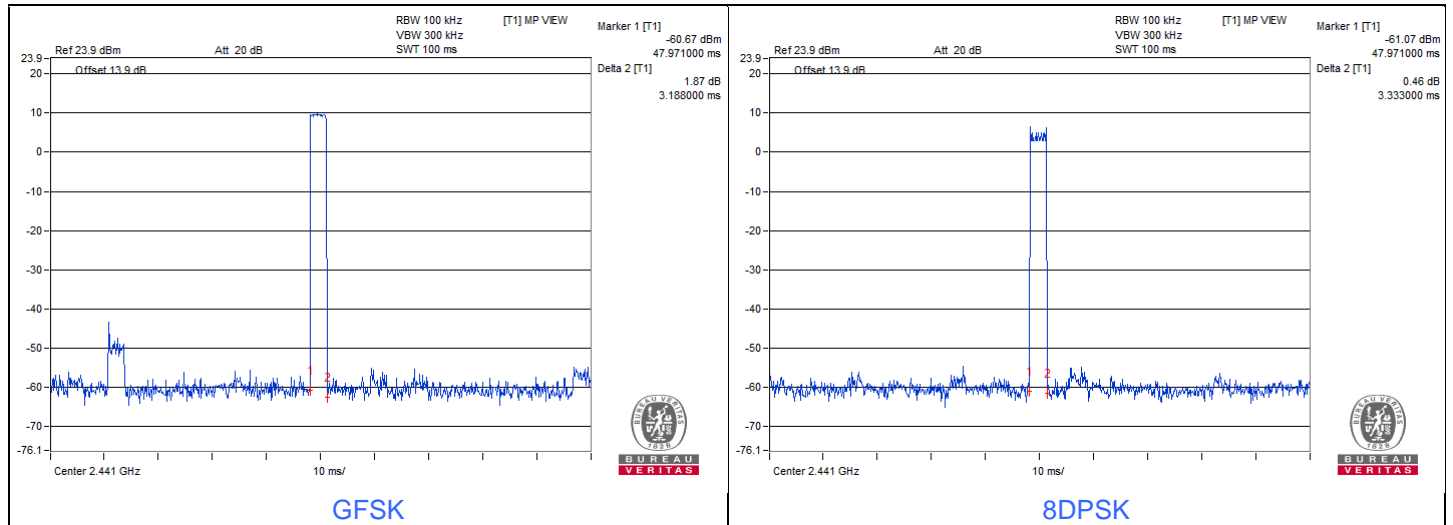

3.6 Test Program Used and Operation Descriptions

Controlling software (BlueSuite.WIN.3.3 Installer_3.3.9.1137) has been activated to set the EUT under transmission condition continuously at specific channel frequency.

3.7 Connection Diagram of EUT and Peripheral Devices

For Radiated Emission test:

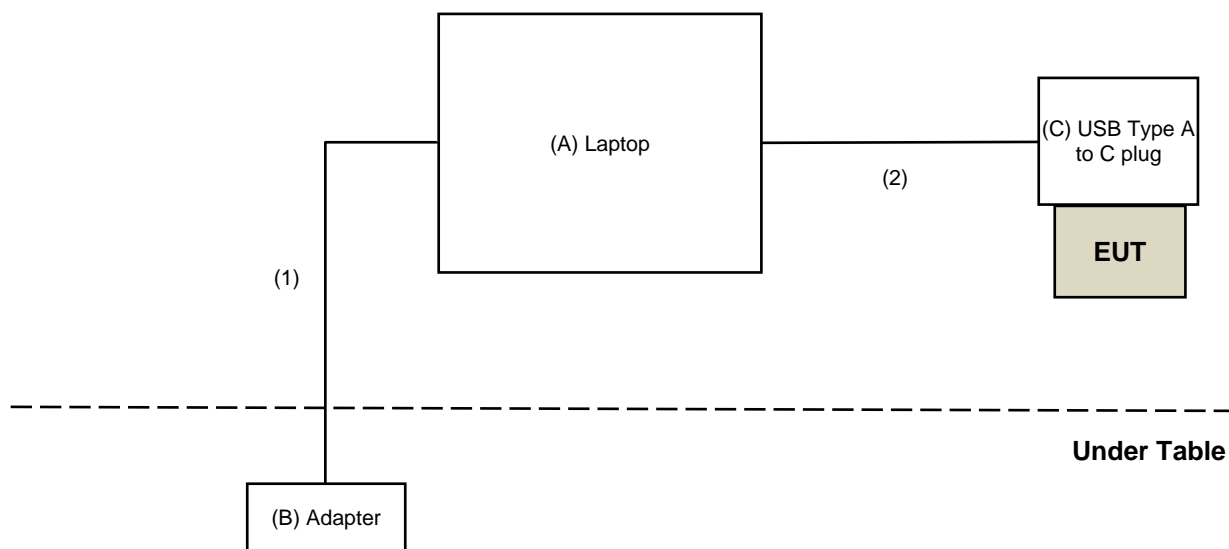

For AC Power Conducted Emission test:

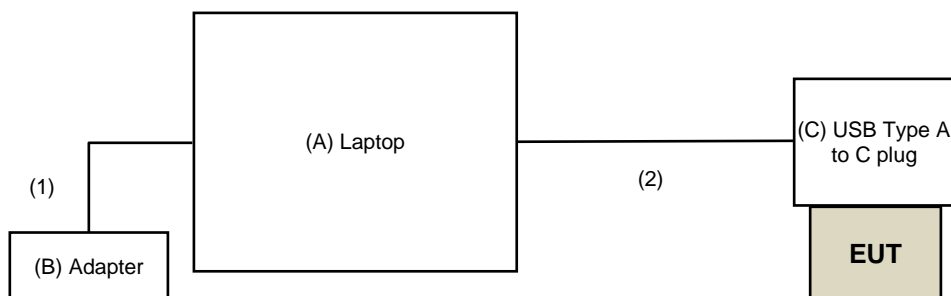

3.8 Configuration of Peripheral Devices and Cable Connections

ID	Product	Brand	Model No.	Serial No.	FCC ID	Remarks
A	Laptop	Lenovo	81A4	YD02YN2A	PD93165NGU	Provided by Lab
B	Adapter	Lenovo	PA-1450-55LL	NA	NA	Provided by Lab
C	USB Type A to C plug	Benevo	BUSB31AMCFA	NA	NA	Provided by Lab

ID	Cable Descriptions	Qty.	Length (m)	Shielding (Yes/No)	Cores (Qty.)	Remarks
1	DC Cable	1	1.8	No	0	Provided by Lab
2	USB extension Cable	1	1.5	Yes	0	Provided by Lab

4 Test Instruments

The calibration interval of the all test instruments are 12 months and the calibrations are traceable to NML/ROC and NIST/USA.

4.1 RF Output Power

Description Manufacturer	Model No.	Serial No.	Calibrated Date	Calibrated Until
Attenuator WOKEN	MDCS18N-10	MDCS18N-10-01	2021/4/13	2022/4/12
Power Meter Anritsu	ML2495A	1529002	2021/6/21	2022/6/20
Pulse Power Sensor Anritsu	MA2411B	1339443	2021/5/31	2022/5/30
Software	ADT_RF Test Software V6.6.5.4	NA	NA	NA
Spectrum Analyzer R&S	FSV40	101516	2021/3/8	2022/3/7

Notes:

1. The test was performed in Oven room 2.
2. Tested Date: 2022/2/8

4.2 Number of Hopping Frequency Used

Refer to section 4.1 to get information of the instruments.

4.3 Dwell Time on Each Channel

Refer to section 4.1 to get information of the instruments.

4.4 Hopping Channel Separation

Refer to section 4.1 to get information of the instruments.

4.5 20dB Bandwidth

Refer to section 4.1 to get information of the instruments.

4.6 Conducted Out of Band Emissions

Refer to section 4.1 to get information of the instruments.

4.7 AC Power Conducted Emissions

Description Manufacturer	Model No.	Serial No.	Calibrated Date	Calibrated Until
50 ohms Terminator	50	3	2021/10/27	2022/10/26
Fixed attenuator STI	STI02-2200-10	005	2021/8/27	2022/8/26
LISN R&S	ESH3-Z5	848773/004	2021/10/29	2022/10/28
LISN R & S	ESH3-Z5	835239/001	2021/3/26	2022/3/25
RF Coaxial Cable JYEBO	5D-FB	COCCAB-001	2021/9/25	2022/9/24
Software BVADT	BVADT_Cond_V7.3.7.4	NA	NA	NA
Test Receiver R&S	ESCS 30	847124/029	2021/10/13	2022/10/12

Notes:

1. The test was performed in Conduction 1
2. Tested Date: 2022/1/28

4.8 Unwanted Emissions below 1 GHz

Description Manufacturer	Model No.	Serial No.	Calibrated Date	Calibrated Until
Bilog Antenna Schwarzbeck	VULB 9168	9168-0842	2021/10/26	2022/10/25
Boresight Antenna Tower & Turn Table Max-Full	MF-7802BS	MF780208530	NA	NA
Fixed attenuator Mini-Circuits	UNAT-5+	PAD-ATT5-02	2022/1/10	2023/1/9
Pre_Amplifier EMCI	EMC330N	980538	2021/4/26	2022/4/25
RF Coaxial Cable COMMATE/PEWC	8D	966-5-1	2021/4/26	2022/4/25
		966-5-2	2021/4/26	2022/4/25
		966-5-3	2021/4/26	2022/4/25
Software	ADT_Radiated_V8.7.08	NA	NA	NA
Spectrum Analyzer KEYSIGHT	N9030B	MY57141948	2021/5/21	2022/5/20
Test Receiver R&S	ESR3	102528	2021/3/2	2022/3/1
Pre_Amplifier EMCI	EMC001340	980142	2021/5/24	2022/5/23
LOOP ANTENNA Electro-Metrics	EM-6879	264	2021/3/5	2022/3/4
RF Coaxial Cable JYEBO	5D-FB	LOOPCAB-001	2022/1/6	2023/1/5
RF Coaxial Cable JYEBO	5D-FB	LOOPCAB-002	2022/1/6	2023/1/5

Notes:

1. The test was performed in 966 Chamber No. 5.
2. Tested Date: 2022/1/28

4.9 Unwanted Emissions above 1 GHz

Description Manufacturer	Model No.	Serial No.	Calibrated Date	Calibrated Until
Boresight Antenna Tower & Turn Table Max-Full	MF-7802BS	MF780208530	NA	NA
Horn Antenna Schwarzbeck	BBHA 9120D	9120D-1819	2021/11/14	2022/11/13
	BBHA 9170	BBHA9170519	2021/11/14	2022/11/13
Pre_Amplifier EMCI	EMC12630SE	980509	2021/4/26	2022/4/25
	EMC184045SE	980387	2022/1/10	2023/1/9
RF cable (40GHz) EMCI	EMC-KM-KM-4000	200214	2021/3/10	2022/3/9
RF Cable-Frequency range: 1- 40GHz EMCI	EMC102-KM-KM-1200	160924	2022/1/10	2023/1/9
RF Coaxial Cable EMCI	EMC104-SM-SM-1500	180503	2021/4/26	2022/4/25
	EMC104-SM-SM-2000	180501	2021/4/26	2022/4/25
	EMC104-SM-SM-6000	180506	2021/4/26	2022/4/25
Software	ADT_Radiated_V8.7.08	NA	NA	NA
Spectrum Analyzer KEYSIGHT	N9030B	MY57141948	2021/5/21	2022/5/20
Test Receiver R&S	ESR3	102528	2021/3/2	2022/3/1

Notes:

1. The test was performed in 966 Chamber No. 5.
2. Tested Date: 2022/1/20 ~ 2022/1/28

5 Limits of Test Items

5.1 RF Output Power

The Maximum Output Power Measurement is 125 mW (21 dBm).

5.2 Number of Hopping Frequency Used

At least 15 channels frequencies, and should be equally spaced.

5.3 Dwell Time on Each Channel

The average time of occupancy on any channel shall not be greater than 0.4 seconds within a period of 0.4 seconds multiplied by the number of hopping channels employed.

5.4 Hopping Channel Separation

At least 25 kHz or two-third of 20 dB hopping channel bandwidth (whichever is greater).

5.5 20dB Bandwidth

The 20 dB bandwidth test value is the reference value for the measurement of the frequency hopping channel interval.

5.6 Conducted Out of Band Emissions

Below 20 dB of the highest emission level of operating band (in 100 kHz Resolution Bandwidth).

5.7 AC Power Conducted Emissions

Frequency (MHz)	Conducted Limit (dBuV)	
	Quasi-peak	Average
0.15 - 0.5	66 - 56	56 - 46
0.50 - 5.0	56	46
5.0 - 30.0	60	50

Notes:

1. The lower limit shall apply at the transition frequencies.
2. The limit decreases in line with the logarithm of the frequency in the range of 0.15 to 0.50 MHz.

5.8 Unwanted Emissions below 1 GHz

Radiated emissions up to 1 GHz which fall in the restricted bands must comply with the radiated emission limits specified as below table. Other emissions shall be at least 20 dB below the highest level of the desired power:

Frequencies (MHz)	Field Strength (microvolts/meter)	Measurement Distance (meters)
0.009 ~ 0.490	2400/F(kHz)	300
0.490 ~ 1.705	24000/F(kHz)	30
1.705 ~ 30.0	30	30
30 ~ 88	100	3
88 ~ 216	150	3
216 ~ 960	200	3
Above 960	500	3

Notes:

1. The lower limit shall apply at the transition frequencies.
2. Emission level (dBuV/m) = 20 log Emission level (uV/m).

5.9 Unwanted Emissions above 1 GHz

Radiated emissions above 1 GHz which fall in the restricted bands must comply with the radiated emission limits specified as below table. Other emissions shall be at least 20 dB below the highest level of the desired power:

Frequencies (MHz)	Field Strength (microvolts/meter)	Measurement Distance (meters)
Above 960	500	3

Notes:

1. The lower limit shall apply at the transition frequencies.
2. Emission level (dBuV/m) = 20 log Emission level (uV/m).
3. For frequencies above 1000 MHz, the field strength limits are based on average detector, however, the peak field strength of any emission shall not exceed the maximum permitted average limits, specified above by more than 20 dB under any condition of modulation.

6 Test Arrangements

6.1 RF Output Power

6.1.1 Test Setup

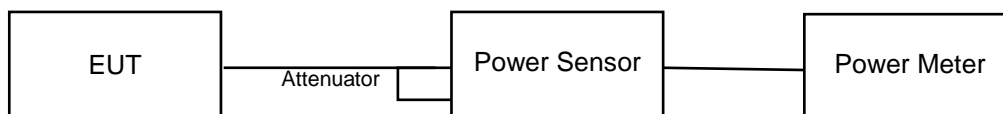

6.1.2 Test Procedure

Peak Power:

A peak power sensor was used on the output port of the EUT. A power meter was used to read the response of the peak power sensor. Record the power level.

Average Power:

Average power sensor was used to perform output power measurement, trigger and gating function of wide band power meter is enabled to measure max output power of TX on burst. Duty factor is not added to measured value.

6.2 Number of Hopping Frequency Used

6.2.1 Test Setup

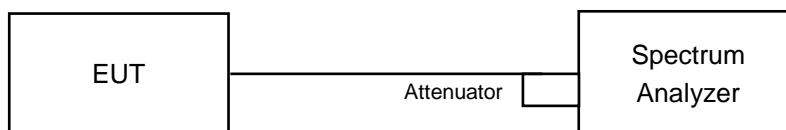

6.2.2 Test Procedure

- a. Check the calibration of the measuring instrument (SA) using either an internal calibrator or a known signal from an external generator.
- b. Turn on the EUT and connect its antenna terminal to measurement via a low loss cable. Then set it to any one measured frequency within its operating range and make sure the instrument is operated in its linear range.
- c. Set the SA on MaxHold Mode, and then keep the EUT in hopping mode. Record all the signals from each channel until each one has been recorded.
- d. Set the SA on View mode and then plot the result on SA screen.
- e. Repeat above procedures until all frequencies measured were complete.

6.3 Dwell Time on Each Channel

6.3.1 Test Setup

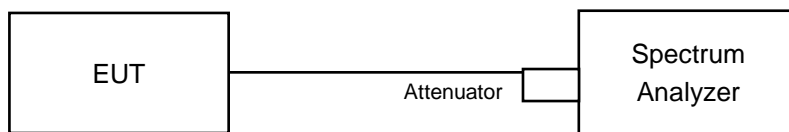

6.3.2 Test Procedure

- Check the calibration of the measuring instrument (SA) using either an internal calibrator or a known signal from an external generator.
- Turn on the EUT and connect its antenna terminal to measurement via a low loss cable. Then set it to any one measured frequency within its operating range and make sure the instrument is operated in its linear range.
- Adjust the center frequency of SA on any frequency be measured and set SA to zero span mode. And then, set RBW and VBW of spectrum analyzer to proper value.
- Measure the time duration of one transmission on the measured frequency. And then plot the result with time difference of this time duration.
- Repeat above procedures until all different time-slot modes have been completed.

6.4 Hopping Channel Separation

6.4.1 Test Setup

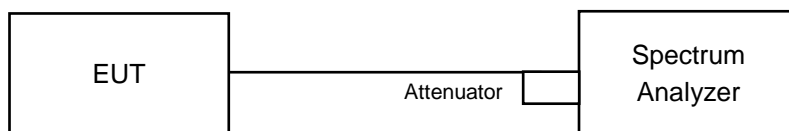

6.4.2 Test Procedure

- Check the calibration of the measuring instrument using either an internal calibrator or a known signal from an external generator.
- Turn on the EUT and connect it to measurement instrument. Then set it to any one convenient frequency within its operating range.
- By using the MaxHold function record the separation of two adjacent channels.
- Measure the frequency difference of these two adjacent channels by SA MARK function. And then plot the result on SA screen.
- Repeat above procedures until all frequencies measured were complete.

6.5 20dB Bandwidth

6.5.1 Test Setup

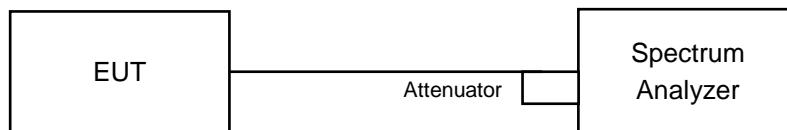

6.5.2 Test Procedure

- Check the calibration of the measuring instrument using either an internal calibrator or a known signal from an external generator.
- Turn on the EUT and connect it to measurement instrument. Then set it to any one convenient frequency within its operating range. Set a reference level on the measuring instrument equal to the highest peak value.
- Measure the frequency difference of two frequencies that were attenuated 20 dB from the reference level. Record the frequency difference as the emission bandwidth.
- Repeat above procedures until all frequencies measured were complete.

6.6 Conducted Out of Band Emissions

6.6.1 Test Setup

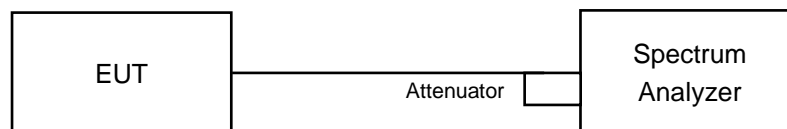

6.6.2 Test Procedure

MEASUREMENT PROCEDURE REF

- Set the RBW = 100 kHz.
- Set the VBW \geq 300 kHz.
- Detector = peak.
- Sweep time = auto couple.
- Trace mode = max hold.
- Allow trace to fully stabilize.
- Use the peak marker function to determine the maximum power level in any 100 kHz band segment within the fundamental EBW.

MEASUREMENT PROCEDURE OOB

- Set RBW = 100 kHz.
- Set VBW \geq 300 kHz.
- Detector = peak.
- Sweep = auto couple.
- Trace Mode = max hold.
- Allow trace to fully stabilize.
- Use the peak marker function to determine the maximum amplitude level.

6.7 AC Power Conducted Emissions

6.7.1 Test Setup

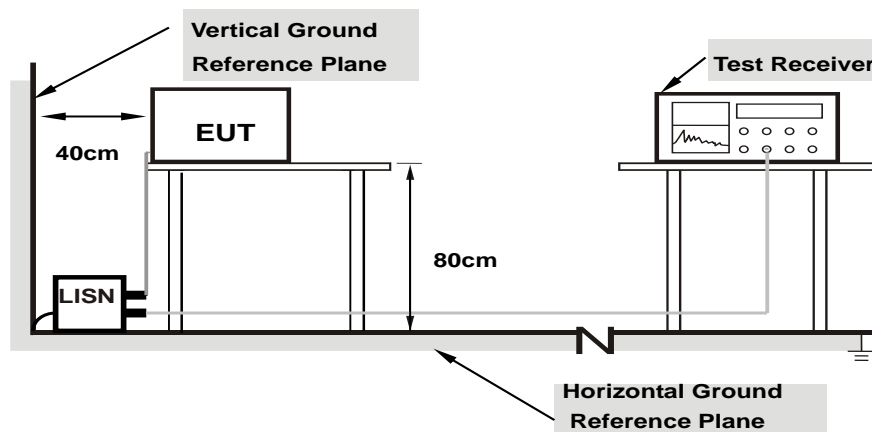

Note: 1. Support units were connected to second LISN.

For the actual test configuration, please refer to the attached file (Test Setup Photo).

6.7.2 Test Procedure

- The EUT was placed 0.4 meters from the conducting wall of the shielded room with EUT being connected to the power mains through a line impedance stabilization network (LISN). Other support units were connected to the power mains through another LISN. The two LISNs provide 50 ohm/ 50 uH of coupling impedance for the measuring instrument.
- Both lines of the power mains connected to the EUT were checked for maximum conducted interference.
- The frequency range from 150 kHz to 30 MHz was searched. Emission levels under (Limit – 20 dB) was not recorded.

Note:

The resolution bandwidth and video bandwidth of test receiver is 9 kHz for quasi-peak detection (QP) and average detection (AV) at frequency 0.15 MHz-30 MHz.

6.8 Unwanted Emissions below 1 GHz

6.8.1 Test Setup

For Radiated emission below 30 MHz

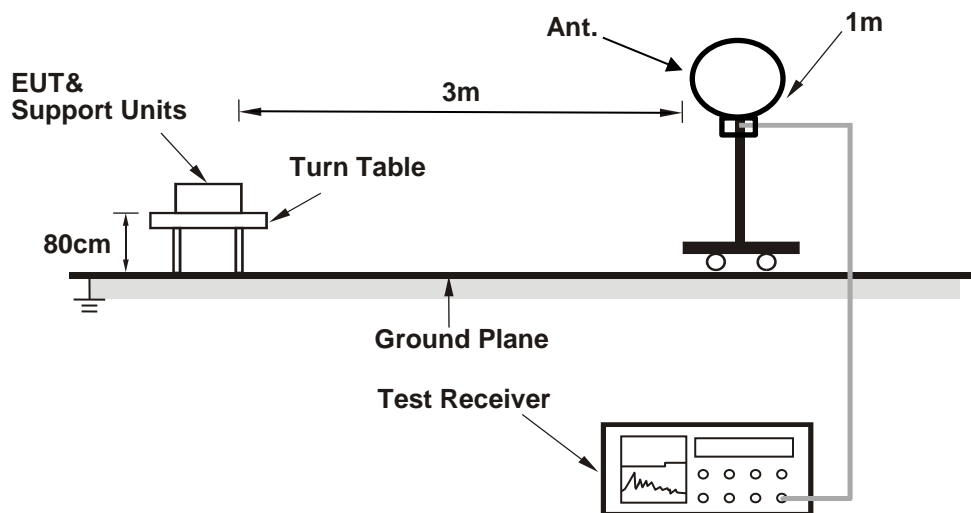

For Radiated emission above 30 MHz

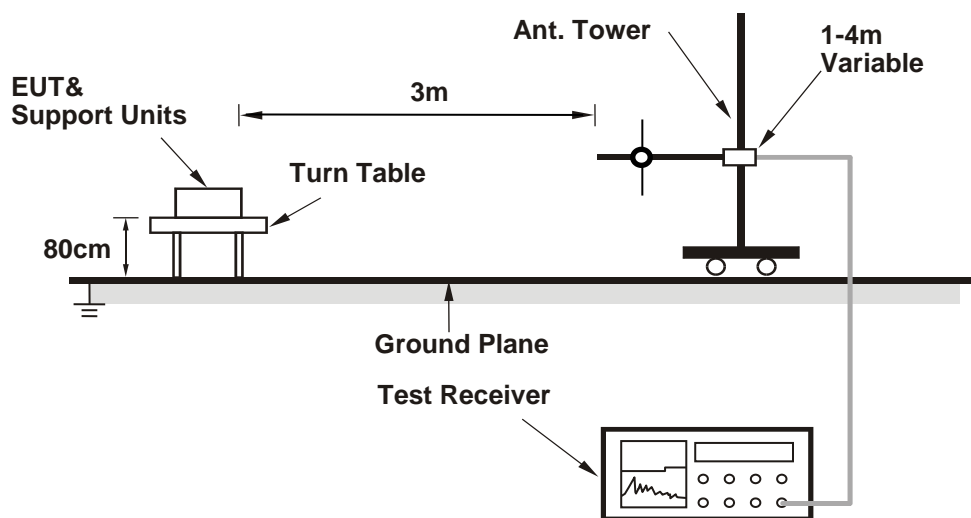

6.8.2 Test Procedure

For Radiated emission below 30 MHz

- a. The EUT was placed on the top of a rotating table 0.8 meters above the ground at 3 meter chamber room for test. The table was rotated 360 degrees to determine the position of the highest radiation.
- b. The EUT was set 3 meters away from the interference-receiving antenna, which was mounted on the top of a variable-height antenna tower.
- c. Parallel, perpendicular, and ground-parallel orientations of the antenna are set to make the measurement.
- d. For each suspected emission, the EUT was arranged to its worst case and the rotatable table was turned from 0 degrees to 360 degrees to find the maximum reading.
- e. The test-receiver system was set to Quasi-Peak Detect Function and Specified Bandwidth with Maximum Hold Mode.

Notes:

1. The resolution bandwidth and video bandwidth of test receiver/spectrum analyzer is 9 kHz at frequency below 30 MHz.
2. All modes of operation were investigated and the worst-case emissions are reported.

For Radiated emission above 30 MHz

- a. The EUT was placed on the top of a rotating table 0.8 meters above the ground at 3 meter chamber room for test. The table was rotated 360 degrees to determine the position of the highest radiation.
- b. The EUT was set 3 meters away from the interference-receiving antenna, which was mounted on the top of a variable-height antenna tower.
- c. The height of antenna is varied from one meter to four meters above the ground to determine the maximum value of the field strength. Both horizontal and vertical polarizations of the antenna are set to make the measurement.
- d. For each suspected emission, the EUT was arranged to its worst case and then the antenna was tuned to heights from 1 meter to 4 meters and the rotatable table was turned from 0 degrees to 360 degrees to find the maximum reading.
- e. The test-receiver system was set to quasi-peak detect function and specified bandwidth with maximum hold mode when the test frequency is below 1 GHz.

Notes:

1. The resolution bandwidth and video bandwidth of test receiver/spectrum analyzer is 120 kHz for Quasi-peak detection (QP) at frequency below 1 GHz.
2. All modes of operation were investigated and the worst-case emissions are reported.

6.9 Unwanted Emissions above 1 GHz

6.9.1 Test Setup

For Radiated emission above 1 GHz

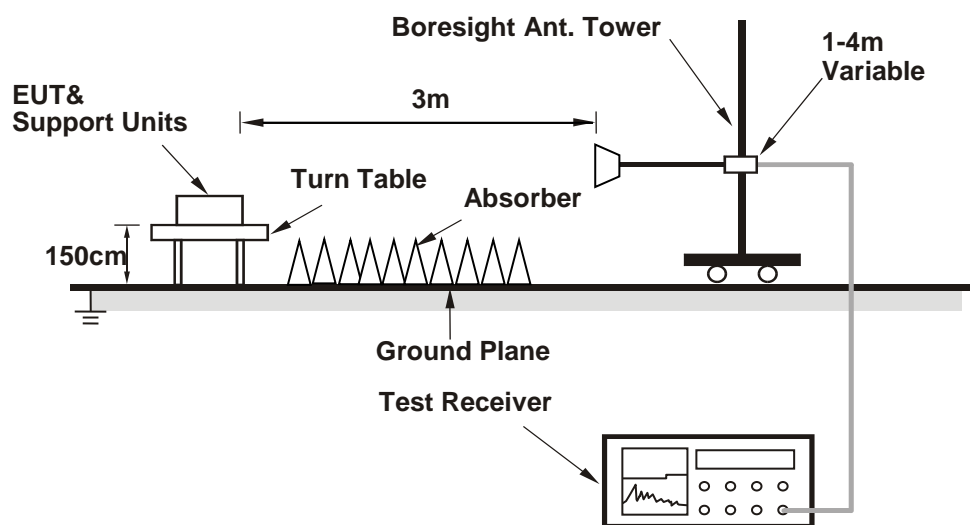

For the actual test configuration, please refer to the attached file (Test Setup Photo).

6.9.2 Test Procedure

- The EUT was placed on the top of a rotating table 1.5 meters above the ground at 3 meter chamber room for test. The table was rotated 360 degrees to determine the position of the highest radiation.
- The EUT was set 3 meters away from the interference-receiving antenna, which was mounted on the top of a variable-height antenna tower.
- The height of antenna is varied from one meter to four meters above the ground to determine the maximum value of the field strength. Both horizontal and vertical polarizations of the antenna are set to make the measurement.
- For each suspected emission, the EUT was arranged to its worst case and then the antenna was tuned to heights from 1 meter to 4 meters and the rotatable table was turned from 0 degrees to 360 degrees to find the maximum reading.
- The test-receiver system was set to peak and average detects function and specified bandwidth with maximum hold mode when the test frequency is above 1 GHz. If the peak reading value also meets average limit, measurement with the average detector is unnecessary.

Notes:

- The resolution bandwidth of test receiver/spectrum analyzer is 1 MHz and the video bandwidth is 3 MHz for Peak detection (PK) and Average detection (AV) at frequency above 1 GHz, according to ANSI C63.10 section 6.6.4 and 4.1.4.2.2. For fundamental and harmonic signal measurement, according to ANSI C63.10 section 7.5, the average value = peak value + duty cycle correction factor. The duty cycle correction factor refer to Chapter 3.5 of this report.
- All modes of operation were investigated and the worst-case emissions are reported.

7 Test Results of Test Item

7.1 RF Output Power

Input Power:	5 Vdc	Environmental Conditions:	25 °C, 60 % RH	Tested By:	Leon Dai
--------------	-------	---------------------------	----------------	------------	----------

For Peak Power

GFSK

Chan.	Chan. Freq. (MHz)	Peak Power (mW)	Peak Power (dBm)	Power Limit (dBm)	Test Result
0	2402	17.66	12.47	21	Pass
39	2441	18.535	12.68	21	Pass
78	2480	18.155	12.59	21	Pass

Note: The antenna gain is -3.01 dBi < 6 dBi, so the output power limit shall not be reduced.

8DPSK

Chan.	Chan. Freq. (MHz)	Peak Power (mW)	Peak Power (dBm)	Power Limit (dBm)	Test Result
0	2402	18.664	12.71	21	Pass
39	2441	19.634	12.93	21	Pass
78	2480	19.231	12.84	21	Pass

Note: The antenna gain is -3.01 dBi < 6 dBi, so the output power limit shall not be reduced.

For Average Power

GFSK

Chan.	Chan. Freq. (MHz)	Average Power (mW)	Average Power (dBm)
0	2402	17.219	12.36
39	2441	18.072	12.57
78	2480	17.701	12.48

8DPSK

Chan.	Chan. Freq. (MHz)	Average Power (mW)	Average Power (dBm)
0	2402	8.872	9.48
39	2441	9.29	9.68
78	2480	9.078	9.58

7.2 Number of Hopping Frequency Used

Input Power:	5 Vdc	Environmental Conditions:	25 °C, 60 % RH	Tested By:	Leon Dai
--------------	-------	---------------------------	----------------	------------	----------

GFSK

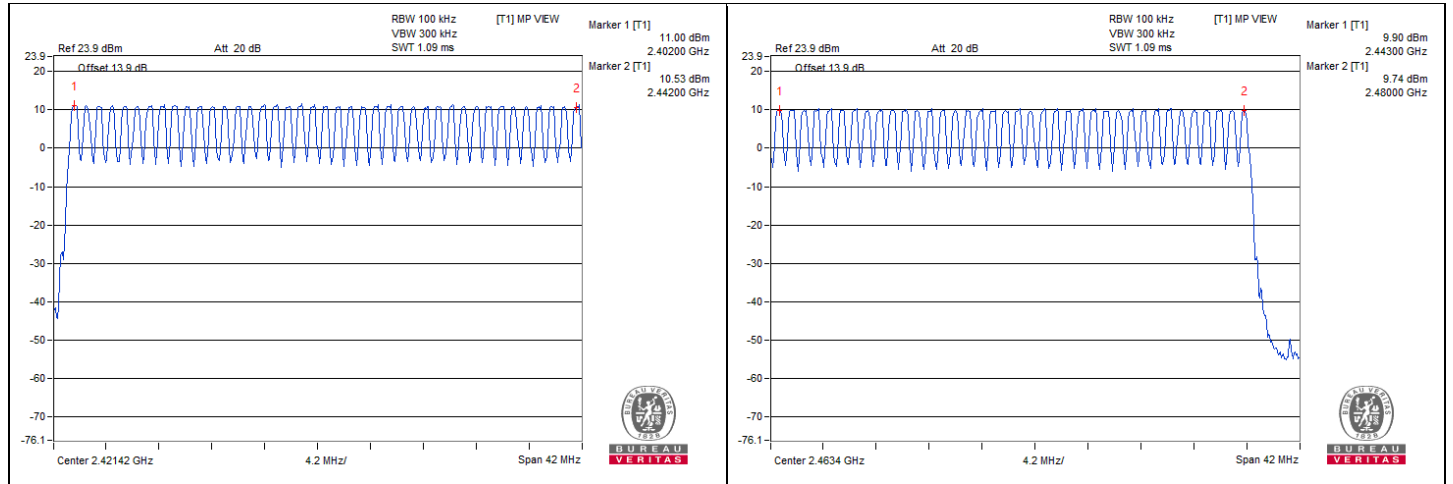

Note: There are 79 hopping frequencies in the hopping mode. On the plots, it shows that the hopping frequencies are equally spaced.

8DPSK

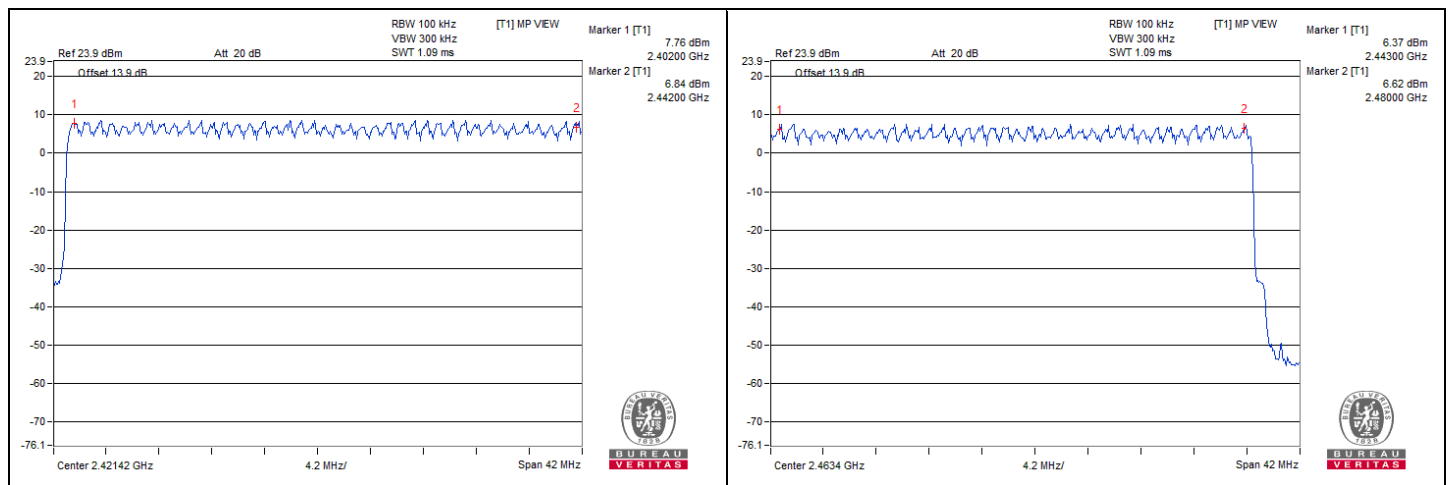

Note: There are 79 hopping frequencies in the hopping mode. On the plots, it shows that the hopping frequencies are equally spaced.



7.3 Dwell Time on Each Channel

Input Power:	5 Vdc	Environmental Conditions:	25 °C, 60 % RH	Tested By:	Leon Dai
--------------	-------	---------------------------	----------------	------------	----------

GFSK

Mode	Number of transmission in 31.6 sec	Length of transmission time (msec)	Result (msec)	Limit (msec)	Test Result
DH1	51 (times / 5 sec) * 6.32 = 323 times	0.426	137.6	400	Pass
DH3	25 (times / 5 sec) * 6.32 = 158 times	1.69	267.02	400	Pass
DH5	17 (times / 5 sec) * 6.32 = 108 times	2.956	319.25	400	Pass

Spectrum plots of the transmitting time slot

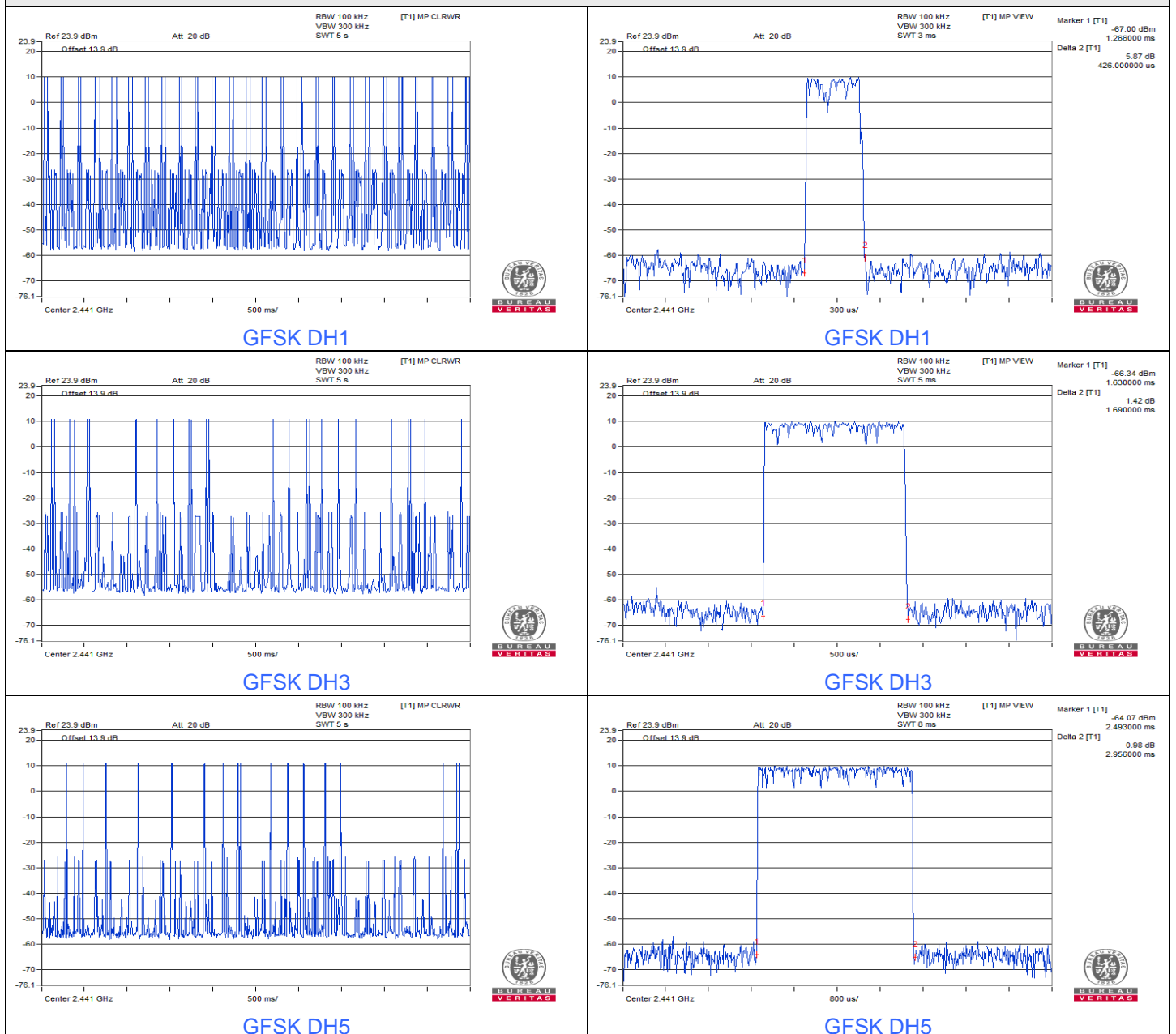

8DPSK

Mode	Number of transmission in 31.6 sec	Length of transmission time (msec)	Result (msec)	Limit (msec)	Test Result
3DH1	51 (times / 5 sec) * 6.32 = 323 times	0.426	137.6	400	Pass
3DH3	25 (times / 5 sec) * 6.32 = 158 times	1.725	272.55	400	Pass
3DH5	17 (times / 5 sec) * 6.32 = 108 times	2.956	319.25	400	Pass

Spectrum plots of the transmitting time slot

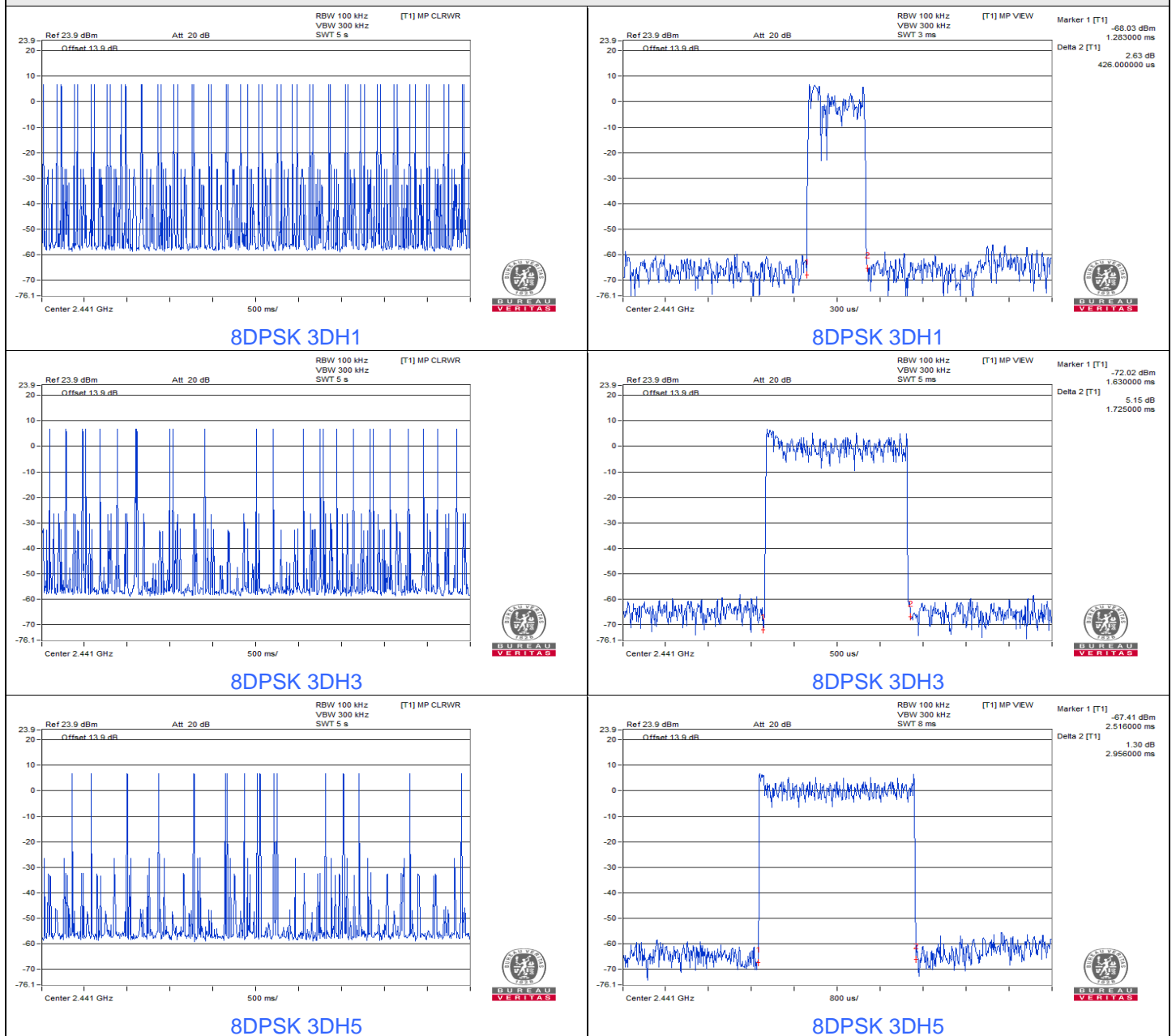



7.4 Hopping Channel Separation

Input Power:	5 Vdc	Environmental Conditions:	25 °C, 60 % RH	Tested By:	Leon Dai
--------------	-------	---------------------------	----------------	------------	----------

GFSK

Channel	Frequency (MHz)	Hopping Channel Separation (MHz)	Minimum Limit (MHz)	Test Result
0	2402	1	0.64	Pass
39	2441	1	0.64	Pass
78	2480	1	0.64	Pass

Note: The minimum limit is two-third 20dB bandwidth.

8DPSK

Channel	Frequency (MHz)	Hopping Channel Separation (MHz)	Minimum Limit (MHz)	Test Result
0	2402	1	0.88	Pass
39	2441	1	0.88	Pass
78	2480	1	0.88	Pass

Note: The minimum limit is two-third 20dB bandwidth.

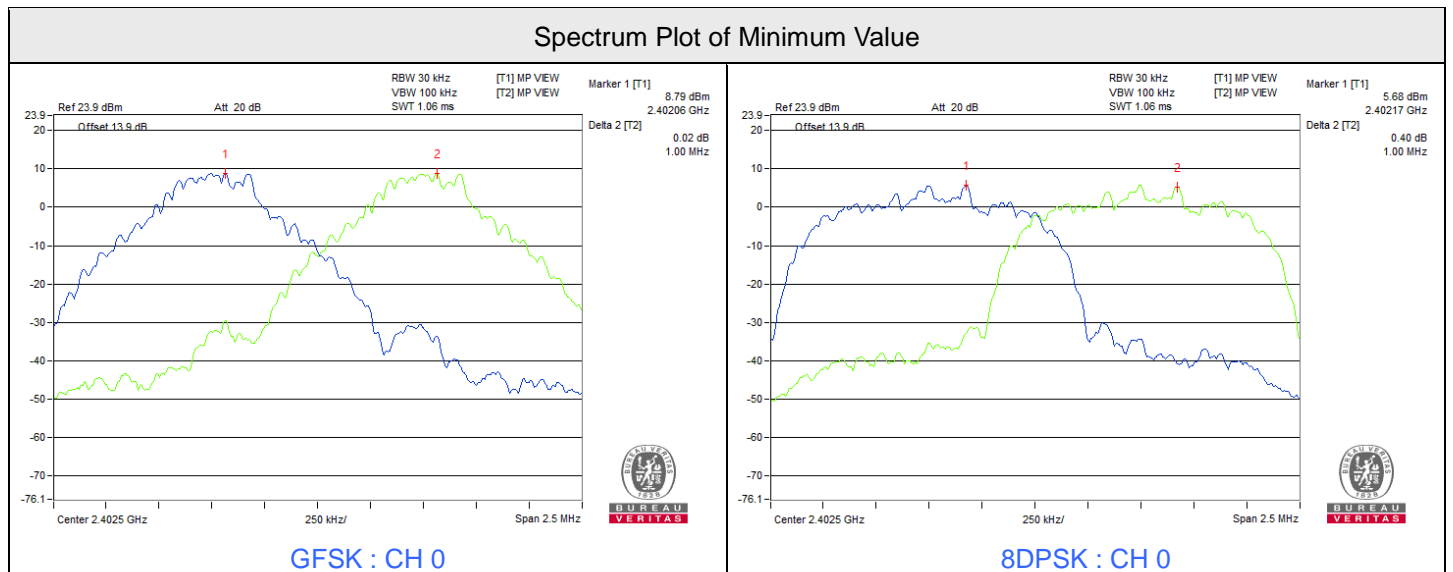

7.5 20dB Bandwidth

Input Power:	5 Vdc	Environmental Conditions:	25 °C, 60 % RH	Tested By:	Leon Dai
--------------	-------	---------------------------	----------------	------------	----------

GFSK

Channel	Frequency (MHz)	20dB Bandwidth (MHz)
0	2402	0.96
39	2441	0.96
78	2480	0.96

8DPSK

Channel	Frequency (MHz)	20dB Bandwidth (MHz)
0	2402	1.31
39	2441	1.31
78	2480	1.31

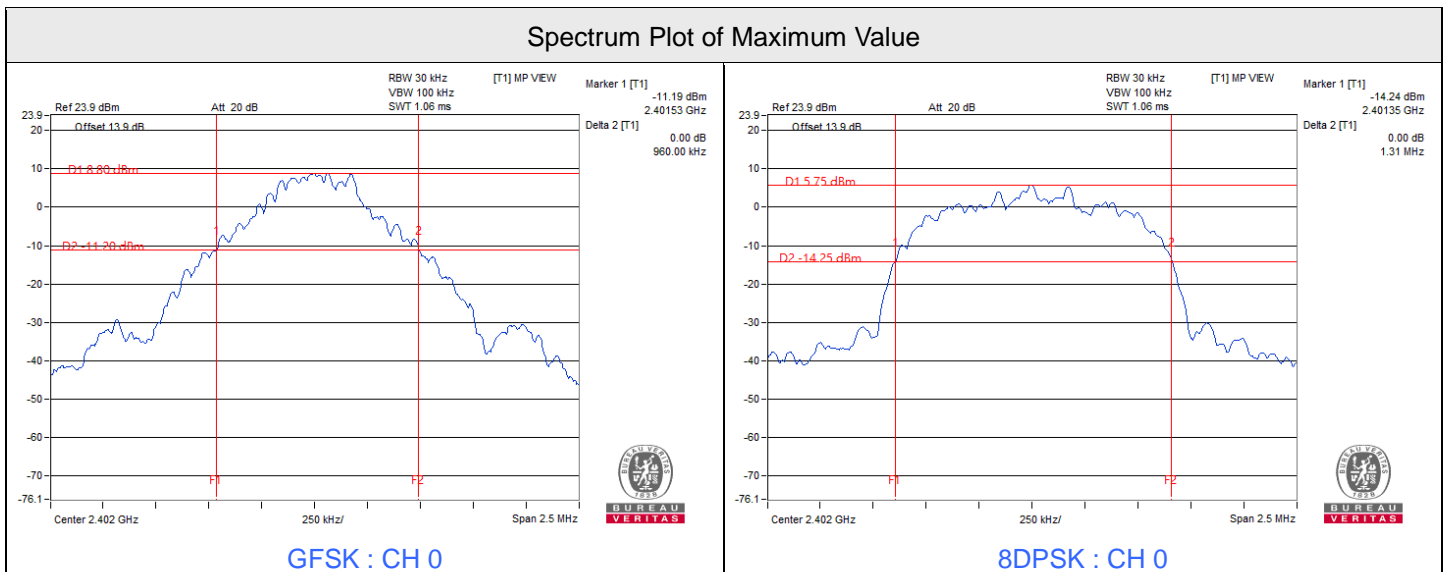



BUREAU VERITAS

7.6 Conducted Out of Band Emissions

Input Power:	5 Vdc	Environmental Conditions:	25 °C, 60 % RH	Tested By:	Leon Dai
--------------	-------	---------------------------	----------------	------------	----------

GFSK

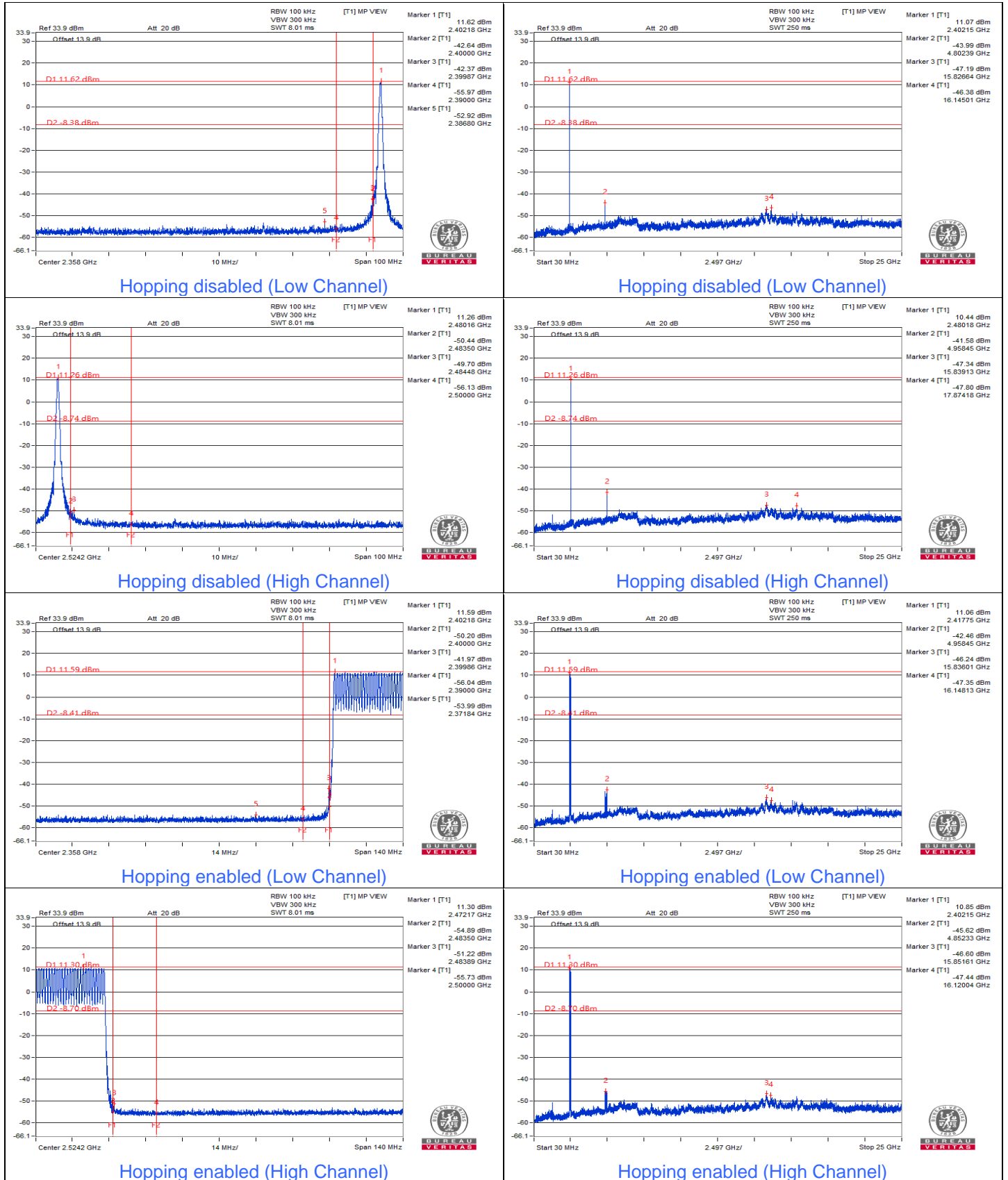



8DPSK

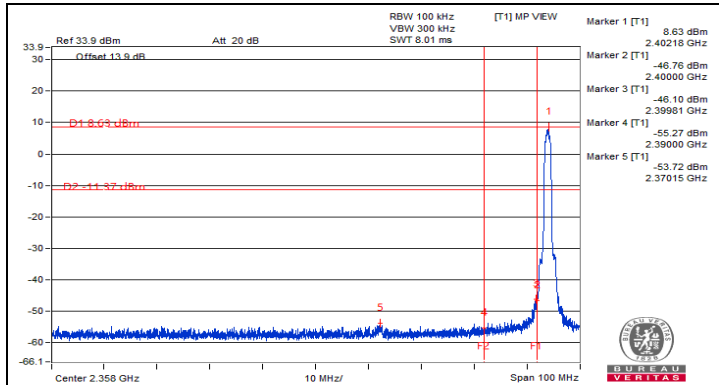

Hopping disabled (Low Channel)

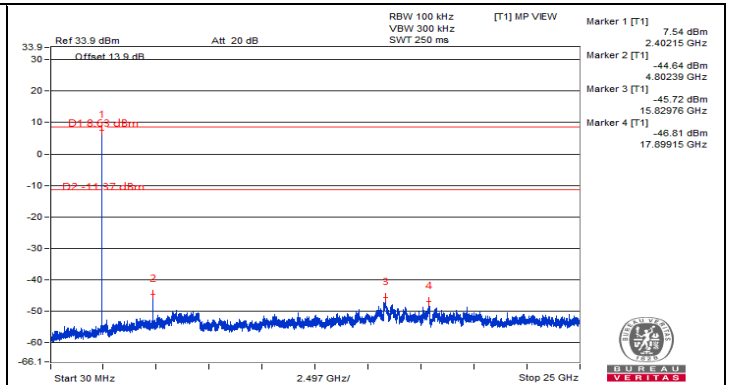

Hopping disabled (Low Channel)

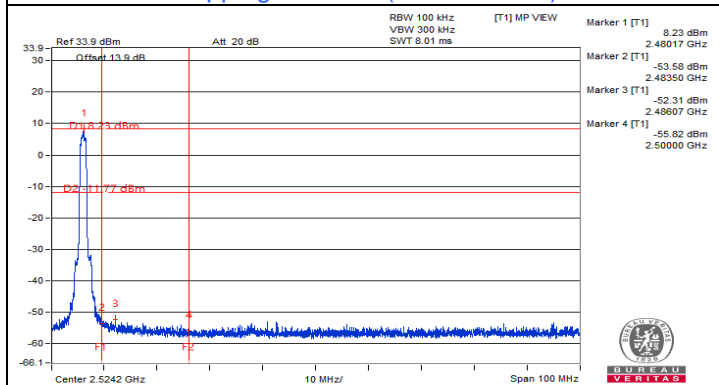

Hopping disabled (High Channel)

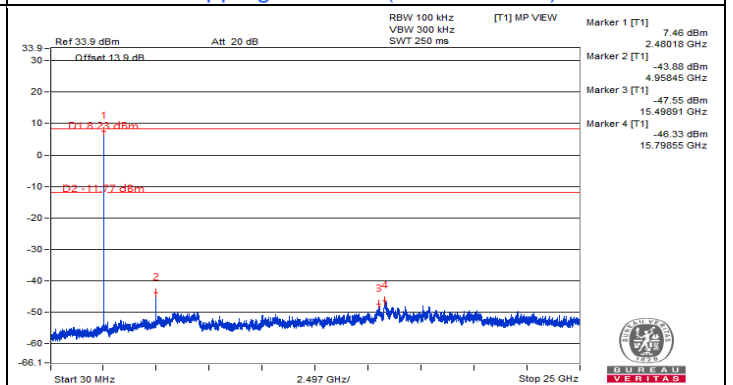

Hopping disabled (High Channel)

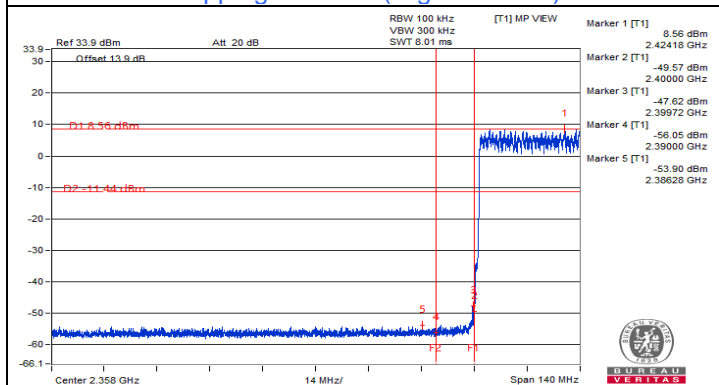

Hopping enabled (Low Channel)

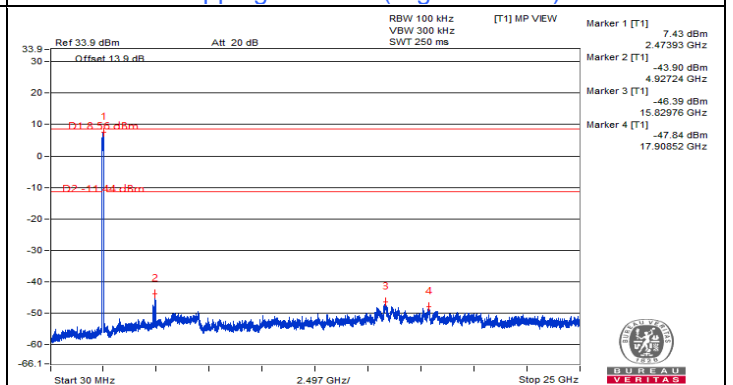

Hopping enabled (Low Channel)

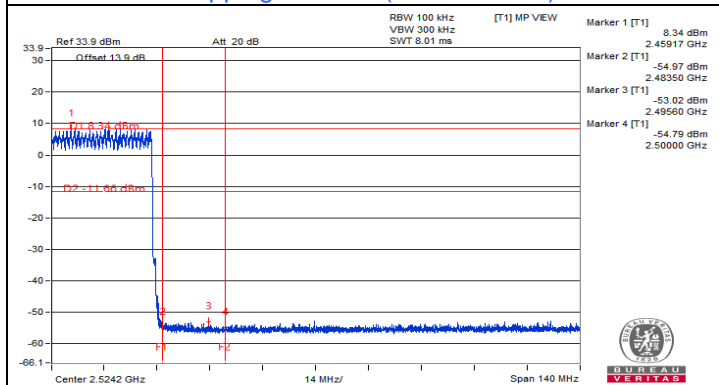

Hopping enabled (High Channel)

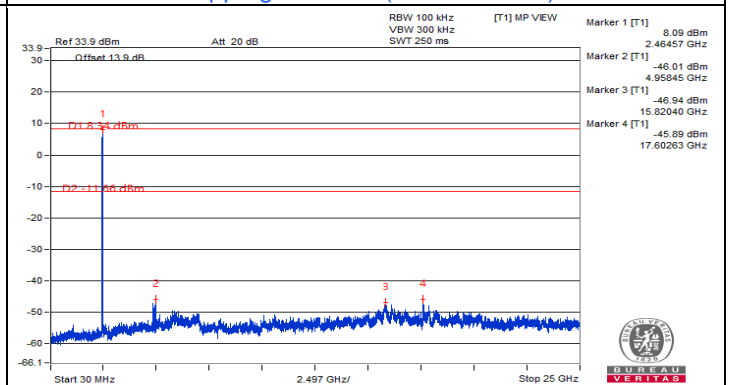

Hopping enabled (High Channel)

7.7 AC Power Conducted Emissions

RF Mode	TX BT_GFSK	Channel	CH 39 : 2441 MHz
Frequency Range	150 kHz ~ 30 MHz	Detector Function & Resolution Bandwidth	Quasi-Peak (QP) / Average (AV), 9 kHz
Input Power (System)	120 Vac, 60 Hz	Environmental Conditions	24 °C, 66 % RH
Tested By	Tom Yang		

Phase Of Power : Line (L)

No	Frequency (MHz)	Correction Factor (dB)	Reading Value (dBuV)		Emission Level (dBuV)		Limit (dBuV)		Margin (dB)	
			Q.P.	AV.	Q.P.	AV.	Q.P.	AV.	Q.P.	AV.
1	0.15391	10.07	39.73	23.91	49.80	33.98	65.79	55.79	-15.99	-21.81
2	0.42344	10.11	29.89	21.04	40.00	31.15	57.38	47.38	-17.38	-16.23
3	0.89609	10.14	21.59	15.23	31.73	25.37	56.00	46.00	-24.27	-20.63
4	2.41406	10.24	20.84	15.23	31.08	25.47	56.00	46.00	-24.92	-20.53
5	8.27344	10.66	18.47	13.19	29.13	23.85	60.00	50.00	-30.87	-26.15
6	20.03906	11.57	21.36	16.28	32.93	27.85	60.00	50.00	-27.07	-22.15

Remarks:

1. Q.P. and AV. are abbreviations of quasi-peak and average individually.
2. The emission levels of other frequencies were very low against the limit.
3. Margin value = Emission level – Limit value
4. Correction factor = Insertion loss + Cable loss
5. Emission Level = Correction Factor + Reading Value

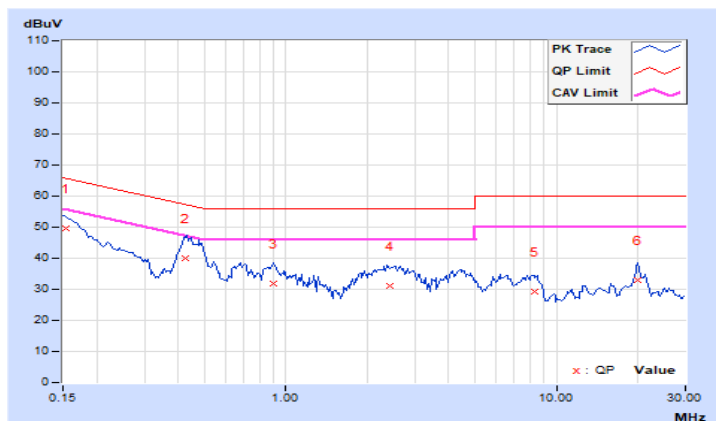

RF Mode	TX BT_GFSK	Channel	CH 39 : 2441 MHz
Frequency Range	150 kHz ~ 30 MHz	Detector Function & Resolution Bandwidth	Quasi-Peak (QP) / Average (AV), 9 kHz
Input Power (System)	120 Vac, 60 Hz	Environmental Conditions	24 °C, 66 % RH
Tested By	Tom Yang		

Phase Of Power : Neutral (N)										
No	Frequency (MHz)	Correction Factor (dB)	Reading Value (dBuV)		Emission Level (dBuV)		Limit (dBuV)		Margin (dB)	
			Q.P.	AV.	Q.P.	AV.	Q.P.	AV.	Q.P.	AV.
1	0.16350	10.06	38.98	23.34	49.04	33.40	65.28	55.28	-16.24	-21.88
2	0.23203	10.08	31.87	15.48	41.95	25.56	62.38	52.38	-20.43	-26.82
3	0.43516	10.10	30.63	21.18	40.73	31.28	57.15	47.15	-16.42	-15.87
4	2.26563	10.23	22.53	16.89	32.76	27.12	56.00	46.00	-23.24	-18.88
5	8.69531	10.60	20.03	13.06	30.63	23.66	60.00	50.00	-29.37	-26.34
6	20.48047	11.29	13.95	10.68	25.24	21.97	60.00	50.00	-34.76	-28.03

Remarks:

1. Q.P. and AV. are abbreviations of quasi-peak and average individually.
2. The emission levels of other frequencies were very low against the limit.
3. Margin value = Emission level – Limit value
4. Correction factor = Insertion loss + Cable loss
5. Emission Level = Correction Factor + Reading Value

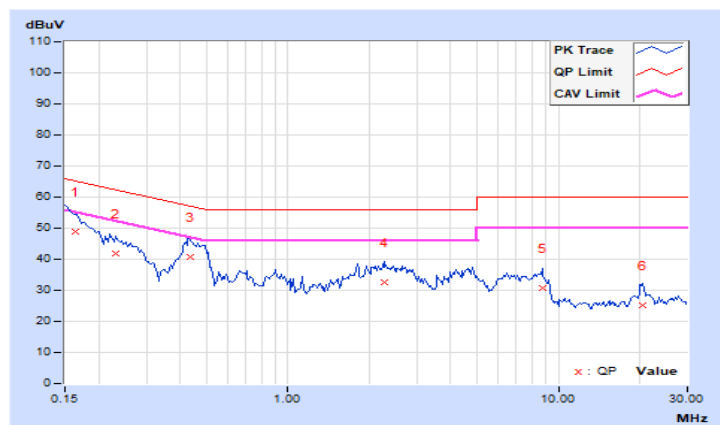

7.8 Unwanted Emissions below 1 GHz

RF Mode	TX BT_GFSK	Channel	CH 39 : 2441 MHz
Frequency Range	9kHz ~ 1GHz	Detector Function	Quasi-Peak (QP)
Input Power (System)	120 Vac, 60 Hz	Environmental Conditions	24 °C, 66 % RH
Tested By	Tom Yang		

Antenna Polarity & Test Distance : Horizontal at 3 m

No	Frequency (MHz)	Emission Level (dBuV/m)	Limit (dBuV/m)	Margin (dB)	Antenna Height (m)	Table Angle (Degree)	Raw Value (dBuV)	Correction Factor (dB/m)
1	58.86	27.4 QP	40.0	-12.6	3.00 H	66	40.5	-13.1
2	152.81	24.1 QP	43.5	-19.4	1.50 H	126	36.8	-12.7
3	199.86	26.7 QP	43.5	-16.8	2.00 H	289	42.8	-16.1
4	311.99	27.9 QP	46.0	-18.1	1.00 H	90	39.8	-11.9
5	431.41	21.4 QP	46.0	-24.6	3.00 H	280	30.2	-8.8
6	597.38	29.3 QP	46.0	-16.7	1.50 H	298	34.5	-5.2

Remarks:

1. Emission Level(dBuV/m) = Raw Value(dBuV) + Correction Factor(dB/m)
2. Correction Factor(dB/m) = Antenna Factor(dB/m) + Cable Factor(dB) – Pre-Amplifier Factor(dB)
3. Margin value = Emission Level – Limit value
4. The other emission levels were very low against the limit of frequency range 30MHz~1000MHz.
5. The emission levels were very low against the limit of frequency range 9kHz~30MHz: the amplitude of spurious emissions attenuated more than 20 dB below the permissible value to be report.

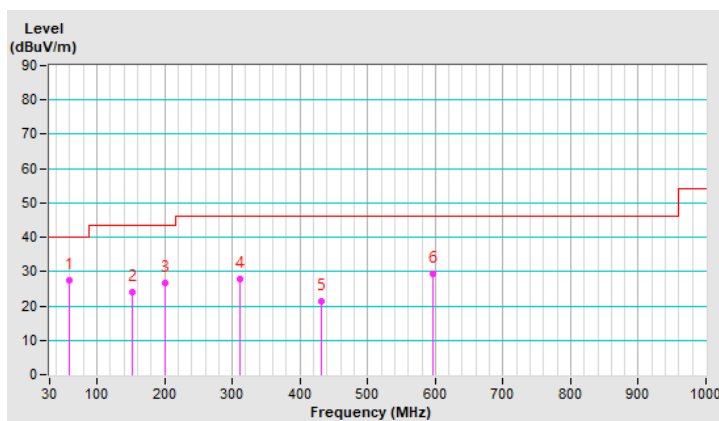

RF Mode	TX BT_GFSK	Channel	CH 39 : 2441 MHz
Frequency Range	9kHz ~ 1GHz	Detector Function	Quasi-Peak (QP)
Input Power (System)	120 Vac, 60 Hz	Environmental Conditions	24 °C, 66 % RH
Tested By	Tom Yang		

Antenna Polarity & Test Distance : Vertical at 3 m								
No	Frequency (MHz)	Emission Level (dBUV/m)	Limit (dBUV/m)	Margin (dB)	Antenna Height (m)	Table Angle (Degree)	Raw Value (dBUV)	Correction Factor (dB/m)
1	59.05	20.2 QP	40.0	-19.8	3.00 V	335	33.3	-13.1
2	90.24	16.8 QP	43.5	-26.7	1.50 V	118	35.4	-18.6
3	152.81	17.3 QP	43.5	-26.2	2.00 V	195	30.0	-12.7
4	229.25	16.4 QP	46.0	-29.6	2.00 V	330	32.0	-15.6
5	347.40	21.2 QP	46.0	-24.8	3.00 V	360	32.5	-11.3
6	443.97	21.4 QP	46.0	-24.6	2.00 V	344	29.8	-8.4

Remarks:

1. Emission Level(dBUV/m) = Raw Value(dBUV) + Correction Factor(dB/m)
2. Correction Factor(dB/m) = Antenna Factor(dB/m) + Cable Factor(dB) – Pre-Amplifier Factor(dB)
3. Margin value = Emission Level – Limit value
4. The other emission levels were very low against the limit of frequency range 30MHz~1000MHz.
5. The emission levels were very low against the limit of frequency range 9kHz~30MHz: the amplitude of spurious emissions attenuated more than 20 dB below the permissible value to be report.

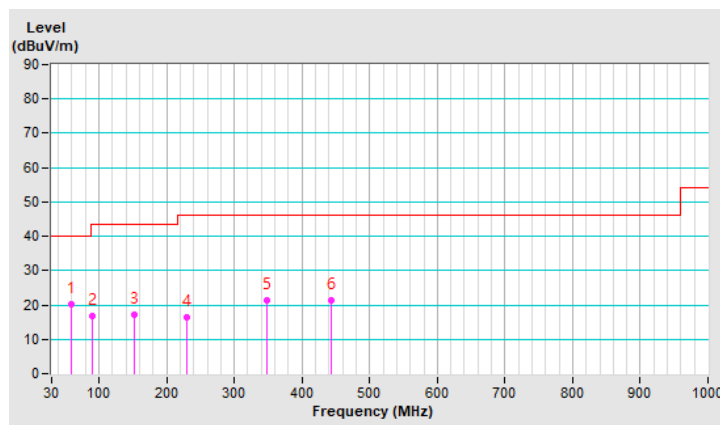

7.9 Unwanted Emissions above 1 GHz

BT_GFSK

RF Mode	TX BT_GFSK	Channel	CH 0 : 2402 MHz
Frequency Range	1GHz ~ 25GHz	Detector Function	Peak (PK) Average (AV)
Input Power (System)	120 Vac, 60 Hz	Environmental Conditions	24 °C, 67 % RH
Tested By	Nelson Teng		

Antenna Polarity & Test Distance : Horizontal at 3 m								
No	Frequency (MHz)	Emission Level (dBuV/m)	Limit (dBuV/m)	Margin (dB)	Antenna Height (m)	Table Angle (Degree)	Raw Value (dBuV)	Correction Factor (dB/m)
1	2390.00	57.2 PK	74.0	-16.8	1.86 H	101	59.9	-2.7
2	2390.00	44.1 AV	54.0	-9.9	1.86 H	101	46.8	-2.7
3	*2402.00	109.8 PK			1.86 H	101	112.5	-2.7
4	*2402.00	79.9 AV			1.86 H	101	82.6	-2.7
5	4804.00	43.7 PK	74.0	-30.3	3.60 H	83	42.2	1.5
6	4804.00	13.8 AV	54.0	-40.2	3.60 H	83	12.3	1.5

Remarks:

- Emission Level(dBuV/m) = Raw Value(dBuV) + Correction Factor(dB/m)
- Correction Factor(dB/m) = Antenna Factor(dB/m) + Cable Factor(dB) – Pre-Amplifier Factor(dB)
- Margin value = Emission Level – Limit value
- The other emission levels were very low against the limit.
- " * ": Fundamental frequency.
- The average value of fundamental and harmonic frequency is: Average = Peak value + 20 log(Duty cycle) Where the duty cycle correction factor is calculated from following formula:
 $20 \log(\text{Duty cycle}) = 20 \log(3.188 \text{ ms} / 100 \text{ ms}) = -29.9 \text{ dB}$ for plotted duty.

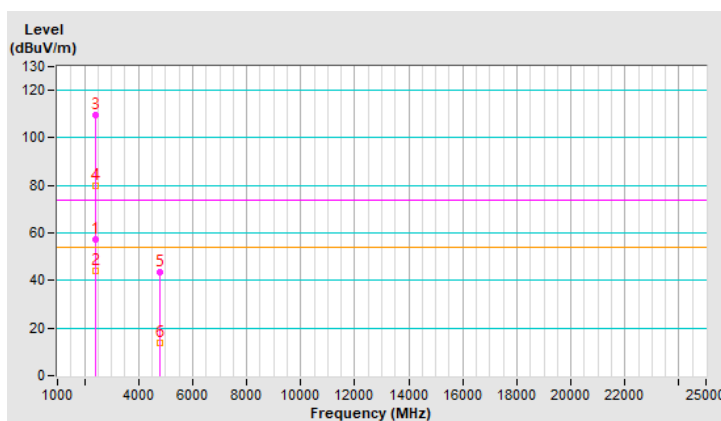

RF Mode	TX BT_GFSK	Channel	CH 0 : 2402 MHz
Frequency Range	1GHz ~ 25GHz	Detector Function	Peak (PK) Average (AV)
Input Power (System)	120 Vac, 60 Hz	Environmental Conditions	24 °C, 67 % RH
Tested By	Nelson Teng		

Antenna Polarity & Test Distance : Vertical at 3 m								
No	Frequency (MHz)	Emission Level (dBuV/m)	Limit (dBuV/m)	Margin (dB)	Antenna Height (m)	Table Angle (Degree)	Raw Value (dBuV)	Correction Factor (dB/m)
1	2390.00	56.4 PK	74.0	-17.6	1.47 V	117	59.1	-2.7
2	2390.00	44.2 AV	54.0	-9.8	1.47 V	117	46.9	-2.7
3	*2402.00	105.5 PK			1.47 V	117	108.2	-2.7
4	*2402.00	75.6 AV			1.47 V	117	78.3	-2.7
5	4804.00	43.1 PK	74.0	-30.9	1.09 V	330	41.6	1.5
6	4804.00	13.2 AV	54.0	-40.8	1.09 V	330	11.7	1.5

Remarks:

- Emission Level(dBuV/m) = Raw Value(dBuV) + Correction Factor(dB/m)
- Correction Factor(dB/m) = Antenna Factor(dB/m) + Cable Factor(dB) – Pre-Amplifier Factor(dB)
- Margin value = Emission Level – Limit value
- The other emission levels were very low against the limit.
- " * ": Fundamental frequency.
- The average value of fundamental and harmonic frequency is: Average = Peak value + 20 log(Duty cycle) Where the duty cycle correction factor is calculated from following formula:
 $20 \log(\text{Duty cycle}) = 20 \log(3.188 \text{ ms} / 100 \text{ ms}) = -29.9 \text{ dB}$ for plotted duty.

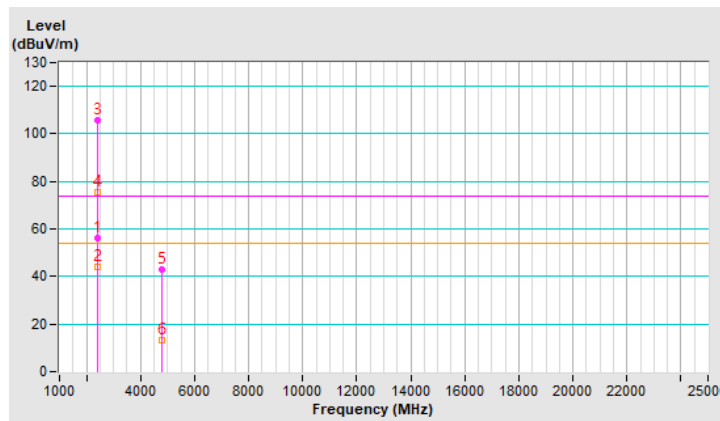

RF Mode	TX BT_GFSK	Channel	CH 39 : 2441 MHz
Frequency Range	1GHz ~ 25GHz	Detector Function	Peak (PK) Average (AV)
Input Power (System)	120 Vac, 60 Hz	Environmental Conditions	24 °C, 67 % RH
Tested By	Nelson Teng		

Antenna Polarity & Test Distance : Horizontal at 3 m								
No	Frequency (MHz)	Emission Level (dBuV/m)	Limit (dBuV/m)	Margin (dB)	Antenna Height (m)	Table Angle (Degree)	Raw Value (dBuV)	Correction Factor (dB/m)
1	*2441.00	110.4 PK			1.92 H	104	113.2	-2.8
2	*2441.00	80.5 AV			1.92 H	104	83.3	-2.8
3	4882.00	43.4 PK	74.0	-30.6	3.77 H	79	41.9	1.5
4	4882.00	13.5 AV	54.0	-40.5	3.77 H	79	12.0	1.5
5	7323.00	46.1 PK	74.0	-27.9	1.13 H	145	38.9	7.2
6	7323.00	16.2 AV	54.0	-37.8	1.13 H	145	9.0	7.2

Remarks:

1. Emission Level(dBuV/m) = Raw Value(dBuV) + Correction Factor(dB/m)
2. Correction Factor(dB/m) = Antenna Factor(dB/m) + Cable Factor(dB) – Pre-Amplifier Factor(dB)
3. Margin value = Emission Level – Limit value
4. The other emission levels were very low against the limit.
5. " * ": Fundamental frequency.
6. The average value of fundamental and harmonic frequency is: Average = Peak value + 20 log(Duty cycle) Where the duty cycle correction factor is calculated from following formula:
 $20 \log(\text{Duty cycle}) = 20 \log(3.188 \text{ ms} / 100 \text{ ms}) = -29.9 \text{ dB}$ for plotted duty.

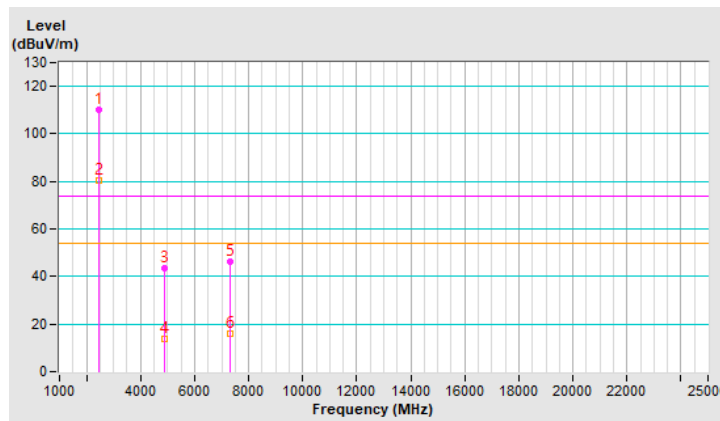

RF Mode	TX BT_GFSK	Channel	CH 39 : 2441 MHz
Frequency Range	1GHz ~ 25GHz	Detector Function	Peak (PK) Average (AV)
Input Power (System)	120 Vac, 60 Hz	Environmental Conditions	24 °C, 67 % RH
Tested By	Nelson Teng		

Antenna Polarity & Test Distance : Vertical at 3 m								
No	Frequency (MHz)	Emission Level (dBuV/m)	Limit (dBuV/m)	Margin (dB)	Antenna Height (m)	Table Angle (Degree)	Raw Value (dBuV)	Correction Factor (dB/m)
1	*2441.00	105.3 PK			1.66 V	109	108.1	-2.8
2	*2441.00	75.4 AV			1.66 V	109	78.2	-2.8
3	4882.00	43.4 PK	74.0	-30.6	1.18 V	339	41.9	1.5
4	4882.00	13.5 AV	54.0	-40.5	1.18 V	339	12.0	1.5
5	7323.00	44.1 PK	74.0	-29.9	1.50 V	80	36.9	7.2
6	7323.00	14.2 AV	54.0	-39.8	1.50 V	80	7.0	7.2

Remarks:

1. Emission Level(dBuV/m) = Raw Value(dBuV) + Correction Factor(dB/m)
2. Correction Factor(dB/m) = Antenna Factor(dB/m) + Cable Factor(dB) – Pre-Amplifier Factor(dB)
3. Margin value = Emission Level – Limit value
4. The other emission levels were very low against the limit.
5. " * ": Fundamental frequency.
6. The average value of fundamental and harmonic frequency is: Average = Peak value + 20 log(Duty cycle) Where the duty cycle correction factor is calculated from following formula:
 $20 \log(\text{Duty cycle}) = 20 \log(3.188 \text{ ms} / 100 \text{ ms}) = -29.9 \text{ dB}$ for plotted duty.

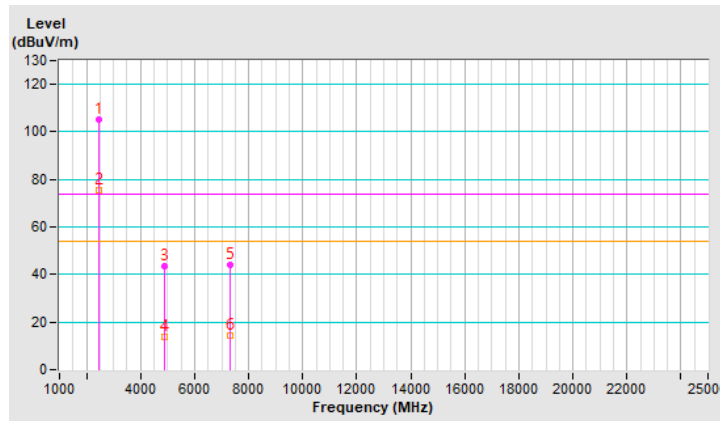

RF Mode	TX BT_GFSK	Channel	CH 78 : 2480 MHz
Frequency Range	1GHz ~ 25GHz	Detector Function	Peak (PK) Average (AV)
Input Power (System)	120 Vac, 60 Hz	Environmental Conditions	24 °C, 67 % RH
Tested By	Nelson Teng		

Antenna Polarity & Test Distance : Horizontal at 3 m								
No	Frequency (MHz)	Emission Level (dBuV/m)	Limit (dBuV/m)	Margin (dB)	Antenna Height (m)	Table Angle (Degree)	Raw Value (dBuV)	Correction Factor (dB/m)
1	*2480.00	111.5 PK			1.63 H	103	114.4	-2.9
2	*2480.00	81.6 AV			1.63 H	103	84.5	-2.9
3	2483.50	65.8 PK	74.0	-8.2	1.63 H	103	68.7	-2.9
4	2483.50	46.2 AV	54.0	-7.8	1.63 H	103	49.1	-2.9
5	4960.00	43.6 PK	74.0	-30.4	3.75 H	90	41.9	1.7
6	4960.00	13.7 AV	54.0	-40.3	3.75 H	90	12.0	1.7
7	7440.00	45.6 PK	74.0	-28.4	1.16 H	133	38.0	7.6
8	7440.00	15.7 AV	54.0	-38.3	1.16 H	133	8.1	7.6

Remarks:

1. Emission Level(dBuV/m) = Raw Value(dBuV) + Correction Factor(dB/m)
2. Correction Factor(dB/m) = Antenna Factor(dB/m) + Cable Factor(dB) – Pre-Amplifier Factor(dB)
3. Margin value = Emission Level – Limit value
4. The other emission levels were very low against the limit.
5. " * ": Fundamental frequency.
6. The average value of fundamental and harmonic frequency is: Average = Peak value + 20 log(Duty cycle) Where the duty cycle correction factor is calculated from following formula:
 $20 \log(\text{Duty cycle}) = 20 \log(3.188 \text{ ms} / 100 \text{ ms}) = -29.9 \text{ dB}$ for plotted duty.

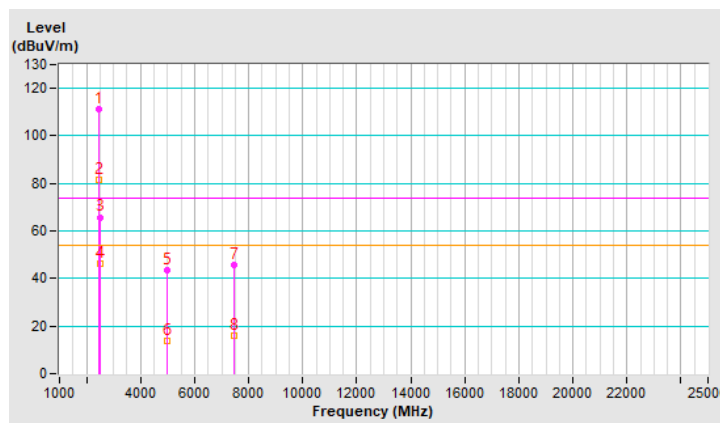

RF Mode	TX BT_GFSK	Channel	CH 78 : 2480 MHz
Frequency Range	1GHz ~ 25GHz	Detector Function	Peak (PK) Average (AV)
Input Power (System)	120 Vac, 60 Hz	Environmental Conditions	24 °C, 67 % RH
Tested By	Nelson Teng		

Antenna Polarity & Test Distance : Vertical at 3 m								
No	Frequency (MHz)	Emission Level (dBuV/m)	Limit (dBuV/m)	Margin (dB)	Antenna Height (m)	Table Angle (Degree)	Raw Value (dBuV)	Correction Factor (dB/m)
1	*2480.00	105.6 PK			1.60 V	118	108.5	-2.9
2	*2480.00	75.7 AV			1.60 V	118	78.6	-2.9
3	2483.50	60.0 PK	74.0	-14.0	1.60 V	118	62.9	-2.9
4	2483.50	44.1 AV	54.0	-9.9	1.60 V	118	47.0	-2.9
5	4960.00	42.9 PK	74.0	-31.1	1.16 V	348	41.2	1.7
6	4960.00	13.0 AV	54.0	-41.0	1.16 V	348	11.3	1.7
7	7440.00	44.4 PK	74.0	-29.6	1.47 V	83	36.8	7.6
8	7440.00	14.5 AV	54.0	-39.5	1.47 V	83	6.9	7.6

Remarks:

1. Emission Level(dBuV/m) = Raw Value(dBuV) + Correction Factor(dB/m)
2. Correction Factor(dB/m) = Antenna Factor(dB/m) + Cable Factor(dB) – Pre-Amplifier Factor(dB)
3. Margin value = Emission Level – Limit value
4. The other emission levels were very low against the limit.
5. " * ": Fundamental frequency.
6. The average value of fundamental and harmonic frequency is: Average = Peak value + 20 log(Duty cycle) Where the duty cycle correction factor is calculated from following formula:
 $20 \log(\text{Duty cycle}) = 20 \log(3.188 \text{ ms} / 100 \text{ ms}) = -29.9 \text{ dB}$ for plotted duty.

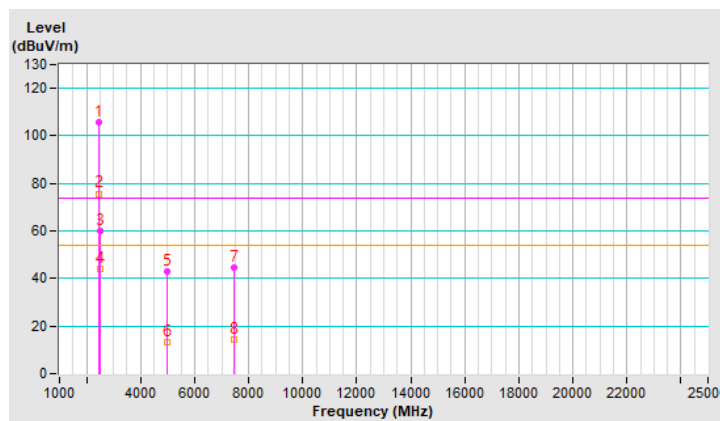

RF Mode	TX BT_8DPSK	Channel	CH 0 : 2402 MHz
Frequency Range	1GHz ~ 25GHz	Detector Function	Peak (PK) Average (AV)
Input Power (System)	120 Vac, 60 Hz	Environmental Conditions	24 °C, 67 % RH
Tested By	Nelson Teng		

Antenna Polarity & Test Distance : Horizontal at 3 m								
No	Frequency (MHz)	Emission Level (dBuV/m)	Limit (dBuV/m)	Margin (dB)	Antenna Height (m)	Table Angle (Degree)	Raw Value (dBuV)	Correction Factor (dB/m)
1	2390.00	56.9 PK	74.0	-17.1	1.87 H	106	59.6	-2.7
2	2390.00	44.4 AV	54.0	-9.6	1.87 H	106	47.1	-2.7
3	*2402.00	109.8 PK			1.87 H	106	112.5	-2.7
4	*2402.00	80.3 AV			1.87 H	106	83.0	-2.7
5	4804.00	43.2 PK	74.0	-30.8	3.75 H	115	41.7	1.5
6	4804.00	13.7 AV	54.0	-40.3	3.75 H	115	12.2	1.5

Remarks:

1. Emission Level(dBuV/m) = Raw Value(dBuV) + Correction Factor(dB/m)
2. Correction Factor(dB/m) = Antenna Factor(dB/m) + Cable Factor(dB) – Pre-Amplifier Factor(dB)
3. Margin value = Emission Level – Limit value
4. The other emission levels were very low against the limit.
5. " * " : Fundamental frequency.
6. The average value of fundamental and harmonic frequency is: Average = Peak value + 20 log(Duty cycle) Where the duty cycle correction factor is calculated from following formula:
 $20 \log(\text{Duty cycle}) = 20 \log(3.333 \text{ ms} / 100 \text{ ms}) = -29.5 \text{ dB}$ for plotted duty.

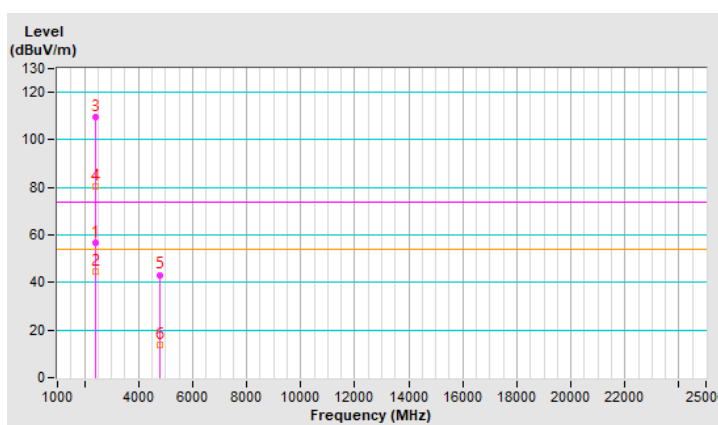

RF Mode	TX BT_8DPSK	Channel	CH 0 : 2402 MHz
Frequency Range	1GHz ~ 25GHz	Detector Function	Peak (PK) Average (AV)
Input Power (System)	120 Vac, 60 Hz	Environmental Conditions	24 °C, 67 % RH
Tested By	Nelson Teng		

Antenna Polarity & Test Distance : Vertical at 3 m								
No	Frequency (MHz)	Emission Level (dBuV/m)	Limit (dBuV/m)	Margin (dB)	Antenna Height (m)	Table Angle (Degree)	Raw Value (dBuV)	Correction Factor (dB/m)
1	2390.00	56.1 PK	74.0	-17.9	1.51 V	116	58.8	-2.7
2	2390.00	44.1 AV	54.0	-9.9	1.51 V	116	46.8	-2.7
3	*2402.00	103.4 PK			1.51 V	116	106.1	-2.7
4	*2402.00	73.9 AV			1.51 V	116	76.6	-2.7
5	4804.00	42.4 PK	74.0	-31.6	1.19 V	343	40.9	1.5
6	4804.00	12.9 AV	54.0	-41.1	1.19 V	343	11.4	1.5

Remarks:

1. Emission Level(dBuV/m) = Raw Value(dBuV) + Correction Factor(dB/m)
2. Correction Factor(dB/m) = Antenna Factor(dB/m) + Cable Factor(dB) – Pre-Amplifier Factor(dB)
3. Margin value = Emission Level – Limit value
4. The other emission levels were very low against the limit.
5. " * " : Fundamental frequency.
6. The average value of fundamental and harmonic frequency is: Average = Peak value + 20 log(Duty cycle) Where the duty cycle correction factor is calculated from following formula:
 $20 \log(\text{Duty cycle}) = 20 \log(3.333 \text{ ms} / 100 \text{ ms}) = -29.5 \text{ dB}$ for plotted duty.

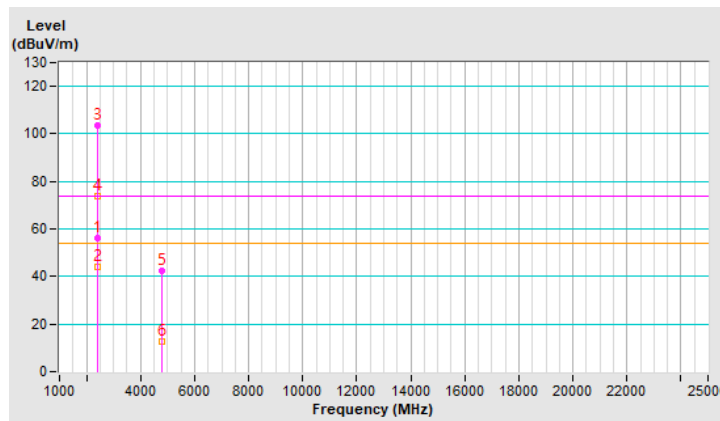

RF Mode	TX BT_8DPSK	Channel	CH 39 : 2441 MHz
Frequency Range	1GHz ~ 25GHz	Detector Function	Peak (PK) Average (AV)
Input Power (System)	120 Vac, 60 Hz	Environmental Conditions	24 °C, 67 % RH
Tested By	Nelson Teng		

Antenna Polarity & Test Distance : Horizontal at 3 m								
No	Frequency (MHz)	Emission Level (dBuV/m)	Limit (dBuV/m)	Margin (dB)	Antenna Height (m)	Table Angle (Degree)	Raw Value (dBuV)	Correction Factor (dB/m)
1	*2441.00	110.0 PK			1.67 H	110	112.8	-2.8
2	*2441.00	80.5 AV			1.67 H	110	83.3	-2.8
3	4882.00	43.6 PK	74.0	-30.4	3.77 H	85	42.1	1.5
4	4882.00	14.1 AV	54.0	-39.9	3.77 H	85	12.6	1.5
5	7323.00	45.9 PK	74.0	-28.1	1.20 H	127	38.7	7.2
6	7323.00	16.4 AV	54.0	-37.6	1.20 H	127	9.2	7.2

Remarks:

1. Emission Level(dBuV/m) = Raw Value(dBuV) + Correction Factor(dB/m)
2. Correction Factor(dB/m) = Antenna Factor(dB/m) + Cable Factor(dB) – Pre-Amplifier Factor(dB)
3. Margin value = Emission Level – Limit value
4. The other emission levels were very low against the limit.
5. " * ": Fundamental frequency.
6. The average value of fundamental and harmonic frequency is: Average = Peak value + 20 log(Duty cycle) Where the duty cycle correction factor is calculated from following formula:
 $20 \log(\text{Duty cycle}) = 20 \log(3.333 \text{ ms} / 100 \text{ ms}) = -29.5 \text{ dB}$ for plotted duty.

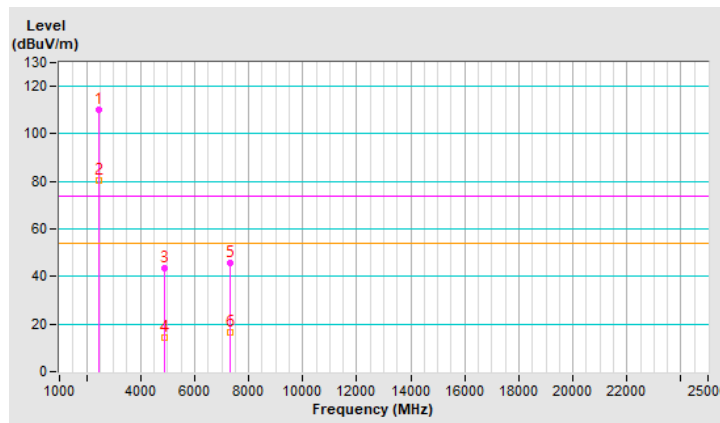

RF Mode	TX BT_8DPSK	Channel	CH 39 : 2441 MHz
Frequency Range	1GHz ~ 25GHz	Detector Function	Peak (PK) Average (AV)
Input Power (System)	120 Vac, 60 Hz	Environmental Conditions	24 °C, 67 % RH
Tested By	Nelson Teng		

Antenna Polarity & Test Distance : Vertical at 3 m								
No	Frequency (MHz)	Emission Level (dBuV/m)	Limit (dBuV/m)	Margin (dB)	Antenna Height (m)	Table Angle (Degree)	Raw Value (dBuV)	Correction Factor (dB/m)
1	*2441.00	104.1 PK			1.56 V	103	106.9	-2.8
2	*2441.00	74.6 AV			1.56 V	103	77.4	-2.8
3	4882.00	42.3 PK	74.0	-31.7	1.19 V	357	40.8	1.5
4	4882.00	12.8 AV	54.0	-41.2	1.19 V	357	11.3	1.5
5	7323.00	43.9 PK	74.0	-30.1	1.52 V	81	36.7	7.2
6	7323.00	14.4 AV	54.0	-39.6	1.52 V	81	7.2	7.2

Remarks:

1. Emission Level(dBuV/m) = Raw Value(dBuV) + Correction Factor(dB/m)
2. Correction Factor(dB/m) = Antenna Factor(dB/m) + Cable Factor(dB) – Pre-Amplifier Factor(dB)
3. Margin value = Emission Level – Limit value
4. The other emission levels were very low against the limit.
5. " * ": Fundamental frequency.
6. The average value of fundamental and harmonic frequency is: Average = Peak value + 20 log(Duty cycle) Where the duty cycle correction factor is calculated from following formula:
 $20 \log(\text{Duty cycle}) = 20 \log(3.333 \text{ ms} / 100 \text{ ms}) = -29.5 \text{ dB}$ for plotted duty.

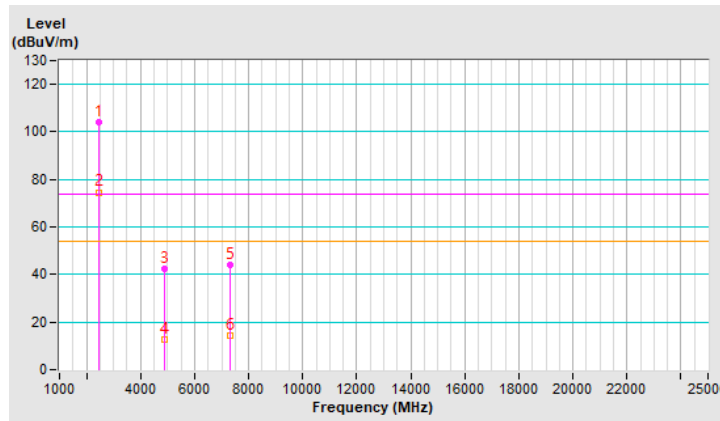

RF Mode	TX BT_8DPSK	Channel	CH 78 : 2480 MHz
Frequency Range	1GHz ~ 25GHz	Detector Function	Peak (PK) Average (AV)
Input Power (System)	120 Vac, 60 Hz	Environmental Conditions	24 °C, 67 % RH
Tested By	Nelson Teng		

Antenna Polarity & Test Distance : Horizontal at 3 m								
No	Frequency (MHz)	Emission Level (dBuV/m)	Limit (dBuV/m)	Margin (dB)	Antenna Height (m)	Table Angle (Degree)	Raw Value (dBuV)	Correction Factor (dB/m)
1	*2480.00	110.3 PK			1.63 H	103	113.2	-2.9
2	*2480.00	80.8 AV			1.63 H	103	83.7	-2.9
3	2483.50	63.6 PK	74.0	-10.4	1.63 H	103	66.5	-2.9
4	2483.50	45.6 AV	54.0	-8.4	1.63 H	103	48.5	-2.9
5	4960.00	43.1 PK	74.0	-30.9	3.71 H	103	41.4	1.7
6	4960.00	13.6 AV	54.0	-40.4	3.71 H	103	11.9	1.7
7	7440.00	46.0 PK	74.0	-28.0	1.16 H	127	38.4	7.6
8	7440.00	16.5 AV	54.0	-37.5	1.16 H	127	8.9	7.6

Remarks:

1. Emission Level(dBuV/m) = Raw Value(dBuV) + Correction Factor(dB/m)
2. Correction Factor(dB/m) = Antenna Factor(dB/m) + Cable Factor(dB) – Pre-Amplifier Factor(dB)
3. Margin value = Emission Level – Limit value
4. The other emission levels were very low against the limit.
5. " * ": Fundamental frequency.
6. The average value of fundamental and harmonic frequency is: Average = Peak value + 20 log(Duty cycle) Where the duty cycle correction factor is calculated from following formula:
 $20 \log(\text{Duty cycle}) = 20 \log(3.333 \text{ ms} / 100 \text{ ms}) = -29.5 \text{ dB}$ for plotted duty.

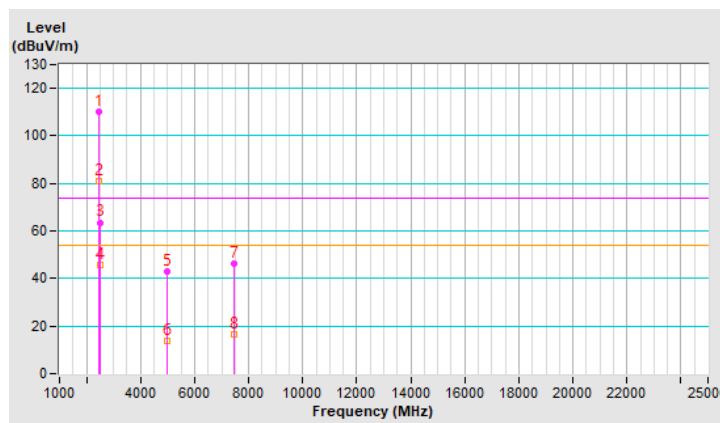

RF Mode	TX BT_8DPSK	Channel	CH 78 : 2480 MHz
Frequency Range	1GHz ~ 25GHz	Detector Function	Peak (PK) Average (AV)
Input Power (System)	120 Vac, 60 Hz	Environmental Conditions	24 °C, 67 % RH
Tested By	Nelson Teng		

Antenna Polarity & Test Distance : Vertical at 3 m								
No	Frequency (MHz)	Emission Level (dBuV/m)	Limit (dBuV/m)	Margin (dB)	Antenna Height (m)	Table Angle (Degree)	Raw Value (dBuV)	Correction Factor (dB/m)
1	*2480.00	104.6 PK			1.58 V	113	107.5	-2.9
2	*2480.00	75.1 AV			1.58 V	113	78.0	-2.9
3	2483.50	58.3 PK	74.0	-15.7	1.58 V	113	61.2	-2.9
4	2483.50	44.3 AV	54.0	-9.7	1.58 V	113	47.2	-2.9
5	4960.00	42.3 PK	74.0	-31.7	1.13 V	345	40.6	1.7
6	4960.00	12.8 AV	54.0	-41.2	1.13 V	345	11.1	1.7
7	7440.00	44.5 PK	74.0	-29.5	1.44 V	85	36.9	7.6
8	7440.00	15.0 AV	54.0	-39.0	1.44 V	85	7.4	7.6

Remarks:

1. Emission Level(dBuV/m) = Raw Value(dBuV) + Correction Factor(dB/m)
2. Correction Factor(dB/m) = Antenna Factor(dB/m) + Cable Factor(dB) – Pre-Amplifier Factor(dB)
3. Margin value = Emission Level – Limit value
4. The other emission levels were very low against the limit.
5. " * ": Fundamental frequency.
6. The average value of fundamental and harmonic frequency is: Average = Peak value + 20 log(Duty cycle) Where the duty cycle correction factor is calculated from following formula:
 $20 \log(\text{Duty cycle}) = 20 \log(3.333 \text{ ms} / 100 \text{ ms}) = -29.5 \text{ dB}$ for plotted duty.

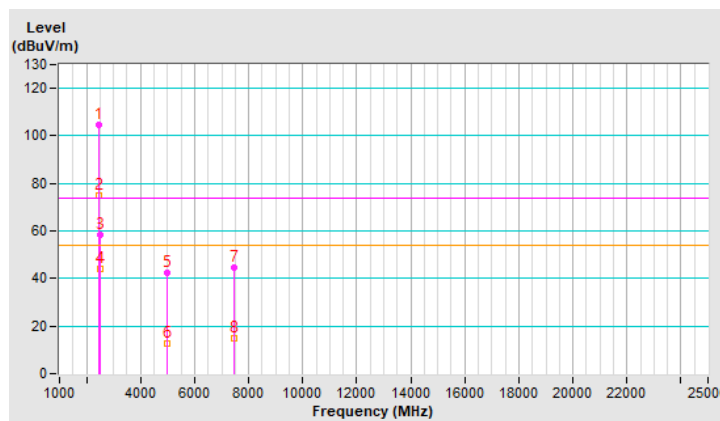

Plot of Band Edge

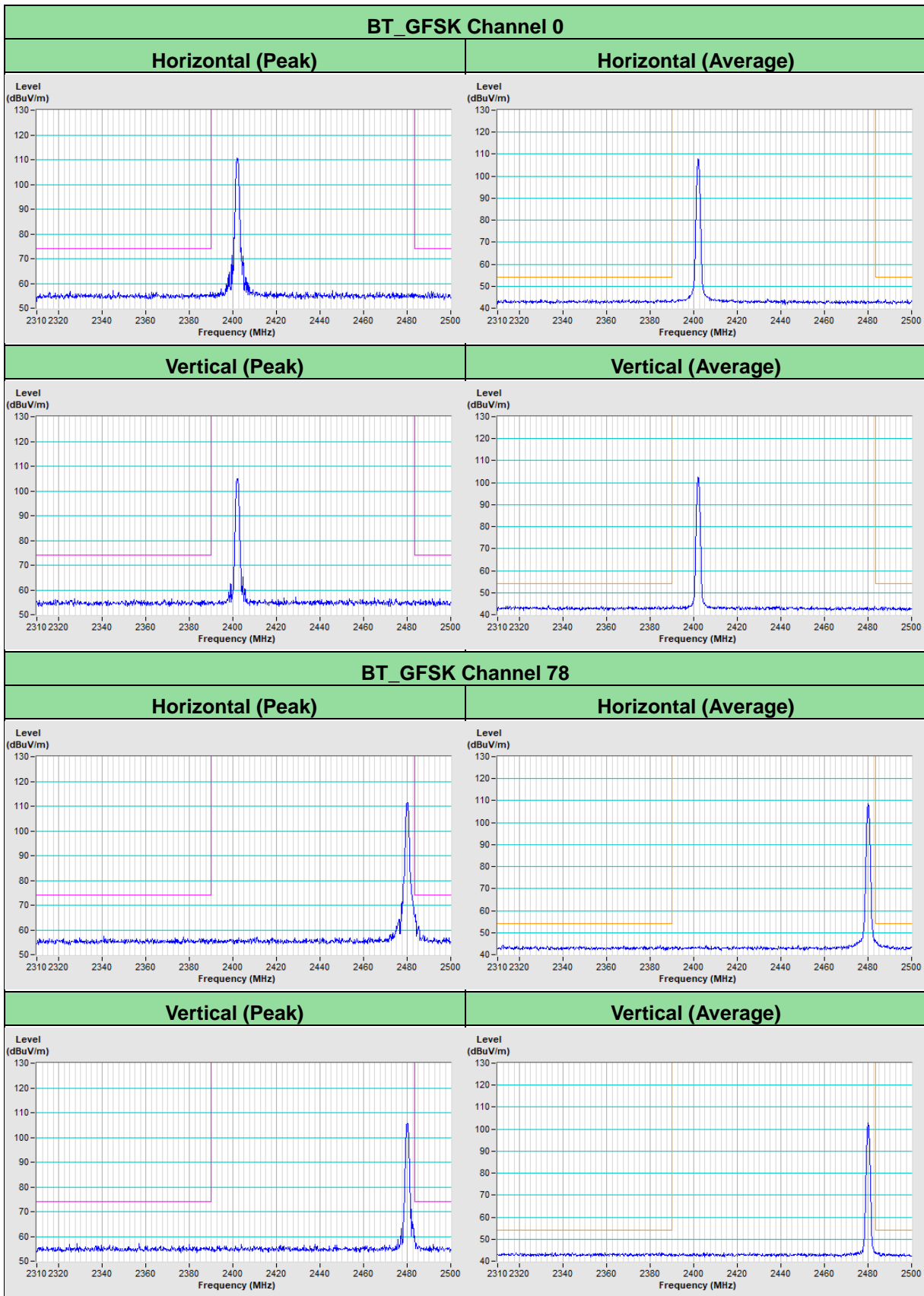

BT_8DPSK Channel 0

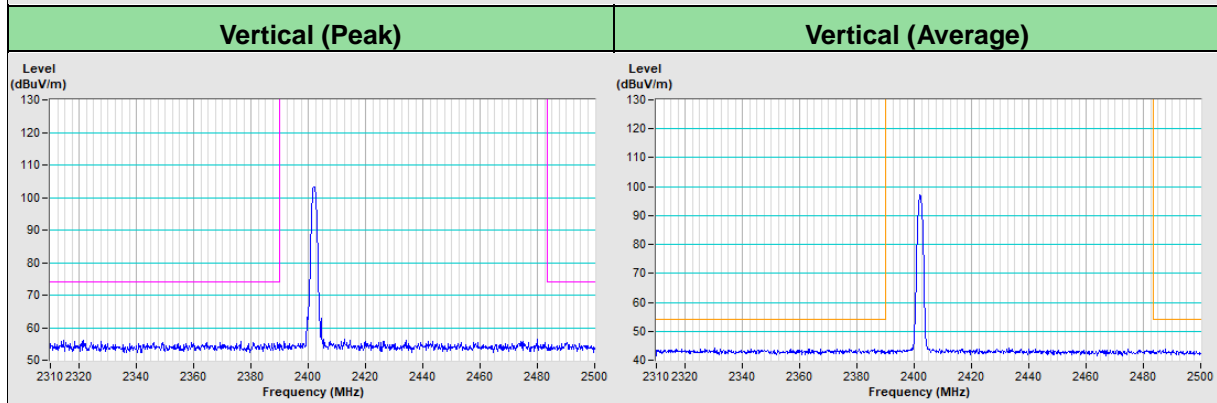
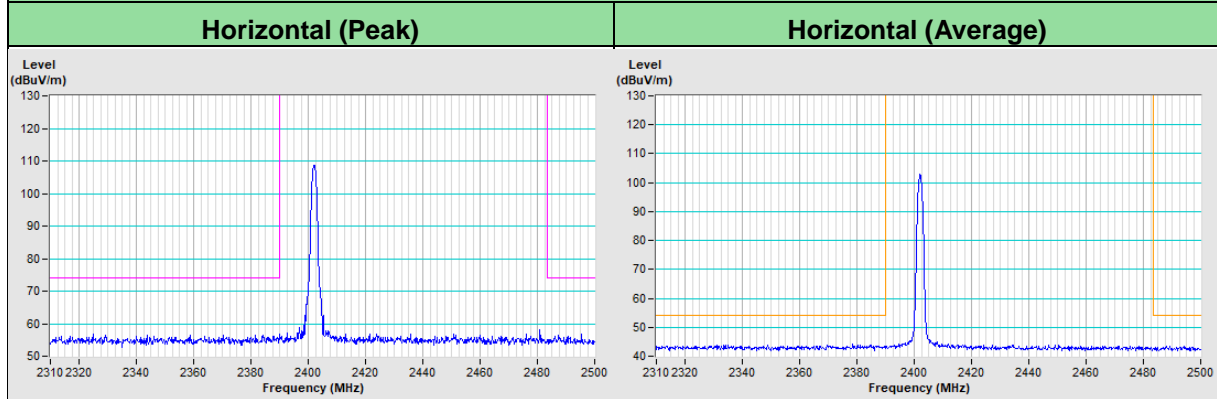

BT_8DPSK Channel 78

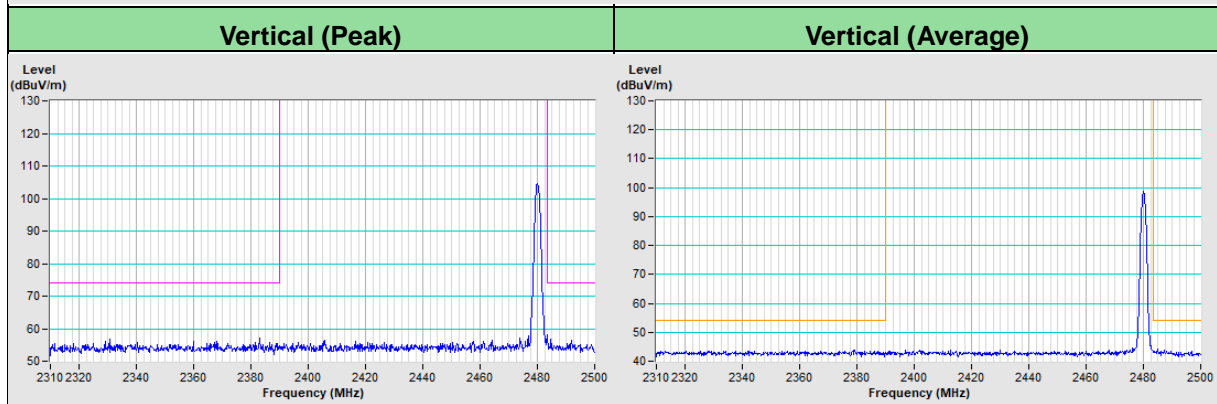
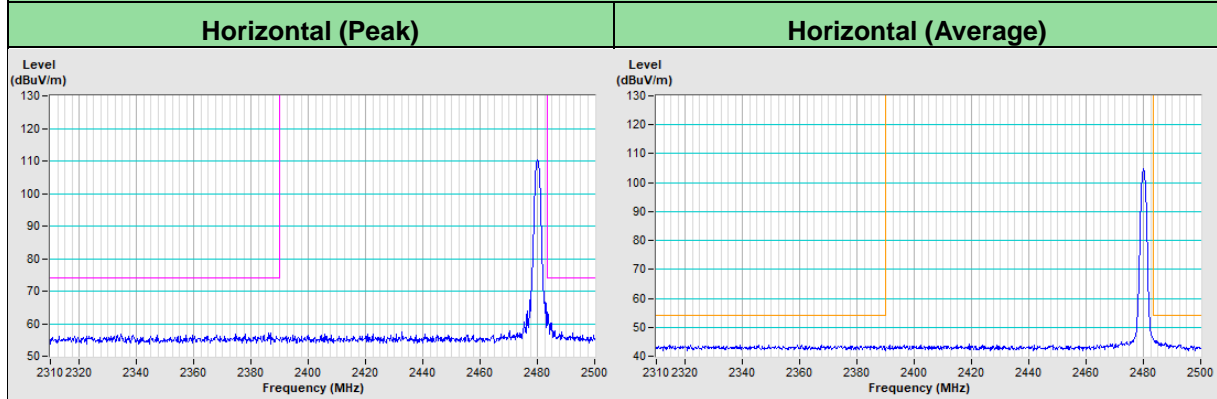

8 Pictures of Test Arrangements

Please refer to the attached file (Test Setup Photo).

9 Information of the Testing Laboratories

We, Bureau Veritas Consumer Products Services (H.K.) Ltd., Taoyuan Branch, were founded in 1988 to provide our best service in EMC, Radio, Telecom and Safety consultation. Our laboratories are FCC recognized accredited test firms and accredited according to ISO/IEC 17025.

If you have any comments, please feel free to contact us at the following:

Lin Kou EMC/RF Lab

Tel: 886-2-26052180

Fax: 886-2-26051924

Hsin Chu EMC/RF/Telecom Lab

Tel: 886-3-6668565

Fax: 886-3-6668323

Hwa Ya EMC/RF/Safety Lab

Tel: 886-3-3183232

Fax: 886-3-3270892

Email: service.adt@bureauveritas.com

Web Site: <http://ee.bureauveritas.com.tw>

The address and road map of all our labs can be found in our web site also.

--- END ---