



FCC TEST REPORT

REPORT NO.: RF930316H05

MODEL NO.: M-RAA93a

RECEIVED: Mar. 16, 2004

TESTED: Mar. 23, 2004

APPLICANT: LOGITECH FAR EAST LTD.

ADDRESS: #2 Creation Rd. 4, Science-Based Ind. Park
Hsinchu Taiwan, R.O.C.

ISSUED BY: Advance Data Technology Corporation

LAB LOCATION: No. 81-1, Lu Liao Keng, 9 Ling, Wu Lung Tsuen,
Chiung Lin Hsiang, Hsin Chu Hsien,
Taiwan, R.O.C.

This test report consists of 15 pages in total. It may be duplicated completely for legal use with the approval of the applicant. It should not be reproduced except in full, without the written approval of our laboratory. The test results in the report only apply to the tested sample.



0536
ILAC MRA



Table of Contents

1	CERTIFICATION.....	3
2	SUMMARY OF TEST RESULTS	4
3	GENERAL INFORMATION	5
3.1	GENERAL DESCRIPTION OF EUT	5
3.2	DESCRIPTION OF TEST MODES	6
3.3	GENERAL DESCRIPTION OF APPLIED STANDARDS.....	6
3.4	DESCRIPTION OF SUPPORT UNITS	7
4	TEST PROCEDURE AND RESULT.....	8
4.1	CONDUCTED EMISSION MEASUREMENT.....	8
4.2	RADIATED EMISSION MEASUREMENT.....	8
4.2.1	LIMITS OF RADIATED EMISSION MEASUREMENT	8
4.2.2	TEST INSTRUMENT	9
4.2.3	TEST PROCEDURE.....	10
4.2.4	DEVIATION FROM TEST STANDARD.....	10
4.2.5	TEST SETUP.....	11
4.2.6	EUT OPERATING CONDITION.....	11
4.2.7	TEST RESULT.....	12
5	PHOTOGRAPHS OF THE TEST CONFIGURATION	14
6	INFORMATION ON THE TESTING LABORATORIES	15



1 CERTIFICATION

PRODUCT : Cordless Mouse
BRAND NAME : Logitech
MODEL NO : M-RAA93a
APPLICANT : LOGITECH FAR EAST LTD.
STANDARDS : 47 CFR Part 15, Subpart C(15.227)
ANSI C63.4-1992

We, **Advance Data Technology Corporation**, hereby certify that one sample of the designation has been tested in our facility on Mar. 23, 2004. The test record, data evaluation and Equipment Under Test (EUT) configurations represented herein are true and accurate accounts of the measurements of the sample's EMC characteristics under the conditions herein specified.

PREPARED BY: Carol Liao, **DATE:** Mar. 25, 2004
(Carol Liao)

APPROVED BY: Eric Lin, **DATE:** Mar. 25, 2004
(Eric Lin, Manager)



2 SUMMARY OF TEST RESULTS

The EUT has been tested according to the following specifications:

APPLIED STANDARD: 47 CFR Part 15, Subpart C			
STANDARD PARAGRAPH	TEST TYPE	RESULT	REMARK
15.207	Conducted Emission Test	N/A	Power supply is 3VDC from batteries
15.227	Radiated Emission Test	PASS	Minimum passing margin is -11.8 dBuV at 190.36 MHz

NOTE: The receiver part to communicate with the EUT has been verified to comply with FCC Part 15, Subpart B, Class B (DoC). The test report can be provided upon request.



3 GENERAL INFORMATION

3.1 GENERAL DESCRIPTION OF EUT

PRODUCT	Cordless Mouse
MODEL NO.	M-RAA93a
POWER SUPPLY	3VDC from battery
MODULATION TYPE	FSK
CARRIER FREQUENCY OF EACH CHANNEL	27.045 MHz, 27.195MHz
NUMBER OF CHANNEL	2
ANTENNA TYPE	Loop antenna
DATA CABLE	NA
I/O PORTS	NA
ASSOCIATED DEVICES	NA

NOTE:

1. The EUT is the transmitter part of Cordless Mouse.
2. For more detailed features description of the EUT, please refer to the manufacturer's specifications or the User's Manual.

3.2 DESCRIPTION OF TEST MODES

There are two channels have been pretested in our facility which are identical to each other in all aspects except for the following:

Mode	Frequency
1	27.045MHz
2	27.195MHz

NOTE: 2 channel sample, the worst case, was chosen for final test and it's data was recorded in this report as bellows,

Mode	Frequency
1	27.195MHz

3.3 GENERAL DESCRIPTION OF APPLIED STANDARDS

The EUT is the transmitter part of a Cordless Mouse. According to the specifications of the manufacturer, it must comply with the requirements of the following standards:

47 CFR Part 15, Subpart C (15.227)

ANSI C63.4-1992

All tests have been performed and recorded as per the above standards.



3.4 DESCRIPTION OF SUPPORT UNITS

The EUT has been tested as an independent unit together with other necessary accessories or support units. The following support units or accessories were used to form a representative test configuration during the tests.

No.	Product	Brand	Model No.	Serial No.	FCC ID
1	PERSONAL COMPUTER	LEO	PERSICA8620G	1A37162B001883	FCC DoC
2	MONITOR	ADI	CM100	026058T10200528	FCC DoC
3	PRINTER	HP	C2642A	MY7961C1FQ	B94C2642X
4	MODEM	ACEEX	1414	0206026773	IFAXDM1414
5	RECEIVER	Logitech	C-BJ27-MSE	NA	FCC DoC
6	KEYBOARD	BTC	KB-5200T	F24800403	E5XKB5122WTH0110

No.	Signal cable description
1	NA
2	1.8 m braid shielded wire, terminated with VGA connector via metallic frame, w/o core
3	1.8 m braid shielded wire, terminated with DB25 and Centronics connector via metallic frame, w/o core.
4	1.0 m braid shielded wire, terminated with DB25 and DB9 connector via metallic frame, w/o core.
5	NA
6	1.8 m foil shielded wire, terminal by frame, PS2 Connector, w/o Core.NA

Note: 1. The power cords of the above support units were unshielded (1.8m).

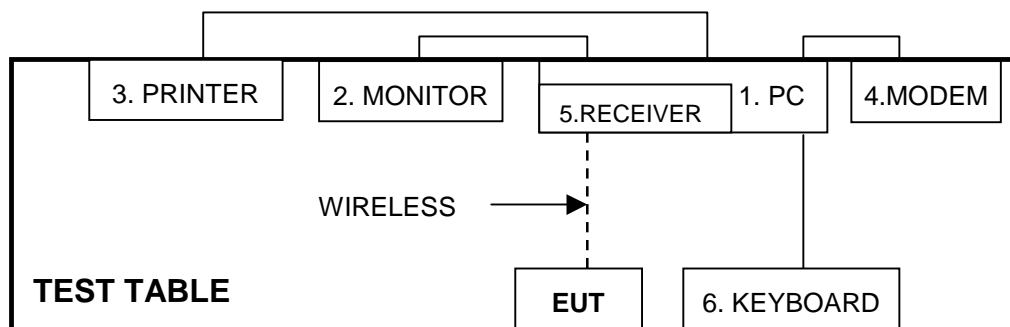

NOTE: 1. Please refer to the photos of test configuration in Item 5 also.



4 TEST PROCEDURE AND RESULT

4.1 CONDUCTED EMISSION MEASUREMENT

NA

4.2 RADIATED EMISSION MEASUREMENT

4.2.1 LIMITS OF RADIATED EMISSION MEASUREMENT

According to 15.227 the field strength of emissions from intentional radiators operated under these frequencies bands shall not exceed the following:

Fundamental Frequency (MHz)	Field Strength of Fundamental (dBuV/m)	
	Peak	Average
26.96-27.28	100	80

Emissions radiated outside of the specified bands, shall be according to the general radiated limits in 15.209 as following:

Frequencies (MHz)	Field strength (microvolts/meter)	Measurement distance (meters)
0.009-0.490	2400/F(kHz)	300
0.490-1.705	24000/F(kHz)	30
1.705-30.0	30	30
30-88	100	3
88-216	150	3
216-960	200	3
Above 960	500	3

As shown in 15.35(b), for frequencies above 1000MHz, the field strength limits are based on average detector, however, the peak field strength of any emission shall not exceed the maximum permitted average limits, specified above by more than 20dB under any condition of modulation.



4.2.2 TEST INSTRUMENT

DESCRIPTION & MANUFACTURER	MODEL NO.	SERIAL NO.	CALIBRATED UNTIL
HP Spectrum Analyzer	8590L	3467U00646	Jun. 29, 2004
*ADVANTEST Spectrum Analyzer	R3271A	85060311	Jun. 16, 2004
CHASE RF Pre_Amplifier	CPA9232	1056	May 12, 2004
*HP Pre_Amplifier	8449B	3008A01922	Oct. 13, 2004
*ROHDE & SCHWARZ Test Receiver	ESVS 30	841977/002	Sep. 17, 2004
*CHASE Broadband Antenna	CBL6112B	2798	Apr. 16, 2004
*Schwarzbeck Horn_Antenna	BBHA9120-D1	D123	Sep. 24, 2004
Schwarzbeck Horn_Antenna	BBHA 9170	BBHA9170192	Feb. 16, 2005
SCHWARZBECK Tunable Dipole Antenna	UHAP	897	Mar. 07, 2005
SCHWARZBECK Tunable Dipole Antenna	VHAP	880	Mar. 07, 2005
*RF Switches	MP59B	1-5161-28698	Jul. 31, 2004
*RF Cable(CHASE)	CH A9525	Cable_OB_01	Jul. 31, 2004
*Software	AS60P8	NA	NA
*CHANCE MOST Antenna Tower	AT-100	CM-A007	NA
*CHANCE MOST Turn Table	TC-008	CM-T007	NA
*CORCOM AC Filter	MRI2030	024/019	NA

Note: 1. The calibration interval of the above test instruments is 12 months (36 months for Tunable Dipole Antenna) and the calibrations are traceable to NML/ROC and NIST/USA.

2. * = These equipment are used for the final measurement.
3. The horn antenna and HP preamplifier (model: 8449B) are used only for the measurement of emission frequency above 1GHz if tested.
4. The test was performed in ADT Open Site No. B.
5. The VCCI Site Registration No. is R-847.
6. The FCC Site Registration No. is 92753.
7. The CANADA Site Registration No. is IC 3789-B.

4.2.3 TEST PROCEDURE

- a. The EUT was placed on the top of a rotating table 0.8 meters above the ground at a 10 meter open area test site. The table was rotated 360 degrees to determine the position of the highest radiation.
- b. The EUT was set 3 meters away from the interference-receiving antenna, which was mounted on the top of a variable-height antenna tower.
- c. The antenna is a broadband antenna, and its height is varied from one meter to four meters above the ground to determine the maximum value of the field strength. Both horizontal and vertical polarizations of the antenna are set to make the measurement.
- d. For each suspected emission, the EUT was arranged to its worst case and then the antenna was tuned to heights from 1 meter to 4 meters and the rotatable table was turned from 0 degrees to 360 degrees to find the maximum reading.
- e. The test-receiver system was set to Peak Detect Function and Specified Bandwidth with Maximum Hold Mode.
- f. If the emission level of the EUT in peak mode was 10 dB lower than the limit specified, then testing could be stopped and the peak values of the EUT would be reported. Otherwise the emissions that did not have 10 dB margin would be re-tested one by one using the quasi-peak method or average method as specified and then reported in Data sheet peak mode and QP mode.

NOTE:

1. The resolution bandwidth and video bandwidth of test receiver/spectrum analyzer is 120kHz for Peak detection (PK) and Quasi-peak detection (QP) at frequency below 1GHz.
2. The resolution bandwidth and video bandwidth of test receiver/spectrum analyzer is 1 MHz for Peak detection at frequency above 1GHz.
3. The resolution bandwidth of test receiver/spectrum analyzer is 1 MHz and the video bandwidth is 300 Hz for Average detection (AV) at frequency above 1GHz.

4.2.4 DEVIATION FROM TEST STANDARD

No deviation

4.2.5 TEST SETUP

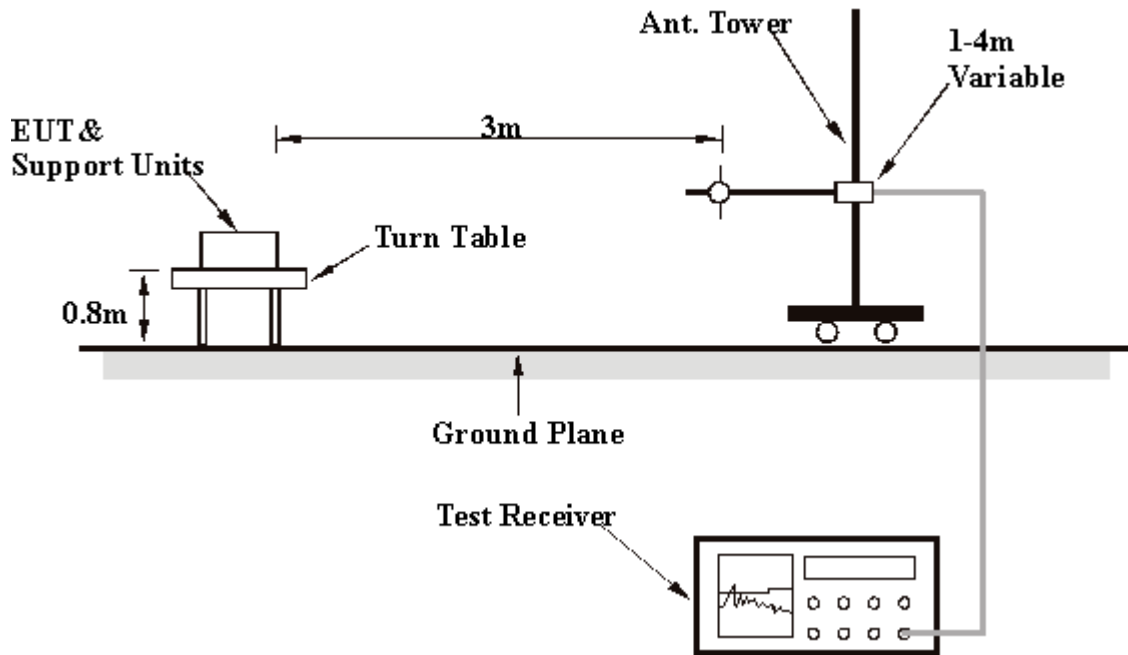

For the actual test configuration, please refer to the related item in this test report - Photographs of the Test Configuration.

4.2.6 EUT OPERATING CONDITION

Set the transmitter part of EUT under transmission condition continuously at specific channel frequency.

4.2.7 TEST RESULT

EUT	Cordless Mouse	MODEL	M-RAA93a
FREQUENCY RANGE	Below 1000 MHz	INPUT POWER	3VDC
ENVIRONMENTAL CONDITIONS	21 deg. C, 59 % RH, 975 hPa	DETECTOR FUNCTION	Peak / Quasi-Peak / Average
TEST BY	Tony Chen		

ANTENNA POLARITY & TEST DISTANCE: HORIZONTAL AT 3 M

No.	Freq. (MHz)	Emission Level (dBuV/m)	Limit (dBuV/m)	Margin (dB)	Antenna Height (m)	Table Angle (Degree)	Raw Value (dBuV)	Correction Factor (dB/m)
1	*27.20	53.2 PK	100.00	-46.8	2.19 H	20	40.4	12.80
2	*27.20	50.1 AV	80.00	-29.9	2.19 H	20	37.3	12.80
3	54.39	15.50 QP	40.00	-24.50	1.97 H	188	3.60	11.90
4	81.58	20.40 QP	40.00	-19.60	2.12 H	179	9.30	11.10
5	108.78	18.50 QP	43.50	-25.00	1.67 H	171	7.50	11.00
6	190.36	31.70 QP	43.50	-11.80	1.75 H	113	19.70	12.00
7	217.56	19.10 QP	46.00	-26.90	1.37 H	290	7.20	11.90
8	271.95	21.70 QP	46.00	-24.30	1.00 H	281	7.60	14.10
9	353.53	21.10 QP	46.00	-24.90	1.04 H	245	4.40	16.70
10	543.90	22.60 QP	46.00	-23.40	1.40 H	342	1.10	21.50

- REMARKS:**
1. Emission level(dBuV/m)=Raw Value(dBuV) + Correction Factor(dB)
 2. Correction Factor(dB/m) = Antenna Factor (dB/m) + Cable Factor (dB)
 3. The other emission levels were very low against the limit.
 4. Margin value = Emission level – Limit value.



EUT	Cordless Mouse	MODEL	M-RAA93a
FREQUENCY RANGE	Below 1000 MHz	INPUT POWER	3VDC
ENVIRONMENTAL CONDITIONS	21 deg. C, 59 % RH, 975 hPa	DETECTOR FUNCTION	Peak / Quasi-Peak / Average
TEST BY	Tony Chen		

ANTENNA POLARITY & TEST DISTANCE: VERTICAL AT 3 M								
No.	Freq. (MHz)	Emission Level (dBuV/m)	Limit (dBuV/m)	Margin (dB)	Antenna Height (m)	Table Angle (Degree)	Raw Value (dBuV)	Correction Factor (dB/m)
1	*27.20	55.9 PK	100.00	-44.1	1.01 V	104	43.1	12.80
2	*27.20	53.5 AV	80.00	-26.5	1.01 V	104	40.7	12.80
3	54.39	23.10 QP	40.00	-16.90	1.57 V	107	11.20	11.90
4	81.58	25.90 QP	40.00	-14.10	1.65 V	72	14.80	11.10
5	108.78	25.10 QP	43.50	-18.40	1.18 V	178	14.10	11.00
6	135.97	19.40 QP	43.50	-24.10	1.00 V	64	6.60	12.80
7	271.95	19.70 QP	46.00	-26.30	1.59 V	113	5.60	14.10
8	299.14	22.30 QP	46.00	-23.70	1.44 V	184	7.10	15.20
9	326.34	22.20 QP	46.00	-23.80	1.56 V	247	6.30	15.90
10	353.53	22.30 QP	46.00	-23.70	1.31 V	157	5.60	16.70

- REMARKS:**
1. Emission level(dBuV/m)=Raw Value(dBuV) + Correction Factor(dB)
 2. Correction Factor(dB/m) = Antenna Factor (dB/m) + Cable Factor (dB)
 3. The other emission levels were very low against the limit.
 4. Margin value = Emission level – Limit value.

5 PHOTOGRAPHS OF THE TEST CONFIGURATION

RADIATED EMISSION TEST





6 INFORMATION ON THE TESTING LABORATORIES

We, ADT Corp., were founded in 1988 to provide our best service in EMC, Radio, Telecom and Safety consultation. Our laboratories are accredited and approved by the following approval agencies according to ISO/IEC 17025, Guide 25 or EN 45001:

USA	FCC, NVLAP, UL
Germany	TUV Rheinland
Japan	VCCI
Norway	NEMKO
Canada	INDUSTRY CANADA , CSA
R.O.C.	CNLA, BSMI, DGT
Netherlands	Telefication
Singapore	PSB , GOST-ASIA(MOU)
Russia	CERTIS(MOU)

Copies of accreditation certificates of our laboratories obtained from approval agencies can be downloaded from our web site: www.adt.com.tw/index.5/phtml.
If you have any comments, please feel free to contact us at the following:

Linko EMC/RF Lab:

Tel: 886-2-26052180

Fax: 886-2-26052943

Hsin Chu EMC/RF Lab:

Tel: 886-3-5935343

Fax: 886-3-5935342

Hwa Ya EMC/RF/Safety Lab:

Tel: 886-3-3183232

Fax: 886-3-3185050

Linko RF & Telecom Lab.

Tel: 886-3-3270910

Fax: 886-3-3270892

Email: service@mail.adt.com.tw

Web Site: www.adt.com.tw

The address and road map of all our labs can be found in our web site also.