



Test Report

Product Name: Wireless Keyboard

Model No.: Y-RJ20/Y-RJ21

FCC ID.: JNZ128177

Applicant : Logitech Far East Ltd.

Address : #2 Creation Rd., 4, Science-Based Ind. Park,
Hsinchu, Taiwan, R.O.C.

Date of Receipt : June 10, 2002

Date of Test : June 18, 2002

Report No. : 026H041FI

The Test Results relate only to the samples tested.

The test report shall not be reproduced except in full without the written approval of Quietek Corporation.

This report must not be used to claim product endorsement by NVLAP any agency of the U.S. Government

Test Report Certification

Test Date : June 18, 2002

Report No. : 026H041FI

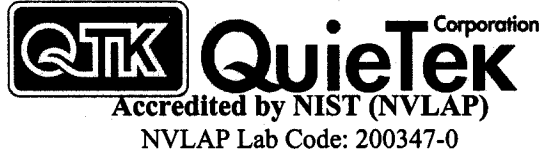

Product Name : Wireless Keyboard

Applicant : Logitech Far East Ltd.

Address : #2 Creation Rd., 4, Science-Based Ind. Park,
Hsinchu, Taiwan, R.O.C.

Manufacturer : Logitech Far East Ltd.

Model No. : Y-RJ20/Y-RJ21

FCC ID. : JNZ128177

Rated Voltage : DC 3V(Power by Battery)

Trade Name : Logitech

Measurement Standard : FCC Part 15 Intentional Radiators for Subpart C
Paragraph 15.227

Measurement Procedure : ANSI C63.4:1992

Test Result : Complied



The Test Results relate only to the samples tested.

The test report shall not be reproduced except in full without the written approval of QuieTek Corporation.

This report must not be used to claim product endorsement by NVLAP any agency of the U.S. Government

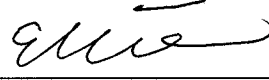
Documented By : 
(Ellie Cheng)

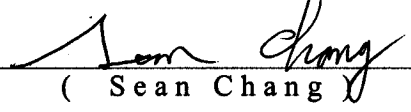
Tested By : 
(Sean Chang)

Approved By : 
(Kevin Wang)

TABLE OF CONTENTS

Description	Page
1. GENERAL INFORMATION.....	4
1.1. EUT Description.....	4
1.2. Operation Description	4
1.3. Tested System Details.....	5
1.4. Configuration of tested System	6
1.5. EUT Exercise Software	6
1.6. Test Facility	7
2. Conducted Emission.....	8
2.1. Test Equipment.....	8
2.2. Test Setup	8
2.3. Limits.....	9
2.4. Test Procedure	9
2.5. Test Result	9
3. Radiated Emission.....	10
3.1. Test Equipment.....	10
3.2. Test Setup	10
3.3. Limits.....	11
3.4. Test Procedure	12
3.5. Test Result	12
4. EMI Reduction Method During Compliance Testing	15
5. Summary of Test Datas	16
5.1. Test Data of Conducted Emission	17
5.2. Test Data of Radiated Emission.....	18
Attachment 1: EUT Test Photographs	
Attachment 2: EUT Detailed Photographs	

1. GENERAL INFORMATION

1.1. EUT Description

Product Name : Wireless Keyboard
Trade Name : Logitech
FCC ID. : JNZ128177
Model No. : Y-RJ20/Y-RJ21
EUT Voltage : DC 3V(Power by Battery)
Frequency Range : 27.095MHz~27.145MHz
Type of Modulation : FSK
Type of antenna : Soldered on PCB
Channel Number : 2
Channel Control : Manual

Frequency of Each Channel:

Channel	Frequency	Channel	Frequency
Channel 1:	27.095 MHz	Channel 2:	27.145 MHz

Note:

1. The EUT is a Wireless Keyboard intends to use in household and office PC system or related application.
2. These tests were conducted on a sample of the equipment for the purpose of demonstrating compliance with Part 15 Subpart C Paragraph 15.227.
3. The variation of model number is for different color of outlook and Hard Key. The circuit of each model is identical.

1.2. Operation Description

The EUT is a 27MHz Wireless Keyboard intends to use in household and office PC system.

The device adapts FSK modulation. The antenna Soldered on PCB Provides diversity function to improve the transmitting function.

The super generation type receiver was used. An external excitation was used when the test of receiver was performed.

1.3. Tested System Details

The types for all equipment, plus descriptions of all cables used in the tested system (including inserted cards) are:

	Product	Manufacturer	Model No.	Serial No.	FCC ID
(1)	PC	IBM	6282-93	960E411	Non-shielded,1.8m
(2)	Monitor	ADi	CM703	038054T10204018 A	Shielded,1.8m
(3)	Printer	HP	C2642A	MY75J1D1D2	Non-Shielded,0.7m
(4)	Joystick	SONY	SCPH-30000	N/A	N/A
(5)	USB Mouse	Logitech	M-UE55	LTC93800382	N/A
(6)	USB Mouse	Logitech	M-UE55	LTC93800397	N/A
(7)	Microphone & Earphone	TOKTO	SX-MI	N/A	N/A
(8)	Walkman	TOBISHI	TB-1027	TBS720102	N/A
(9)	Modem	ACEEX	2814	960018054	N/A
(10)	Receiver	Logitech	C-BF16-MSE	N/A	N/A

	Signal Cable Type	Signal cable Description
A.	VGA Cable	Shielded, 1.6m, a ferrite core bonded
B.	Signal Cable (RX)	Shielded, 1.5m, a ferrite core bonded
C.	Joystick Cable	Shielded, 1.8m
D.	USB Mouse Cable	Shielded, 1.8m
E.	USB Mouse Cable	Shielded, 1.8m
F.	Printer Cable	Shielded, 1.2m
G.	Modem Cable	Shielded, 1.6m
H.	Walkman Cable	Non-shielded, 1.6m
I.	Microphone & Earphone Cable	Non-shielded, 1.8m

1.4. Configuration of tested System

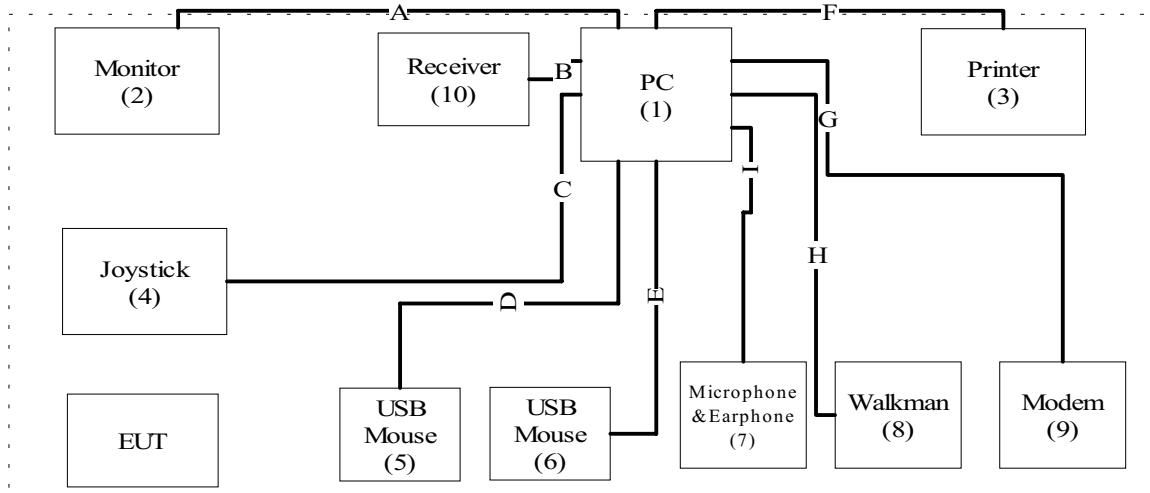

1.5. EUT Exercise Software

- (1) Setup the EUT and simulators as shown on 1.4.
- (2) Enable RF signal and confirm EUT active.
- (3) Modulate output capacity of EUT up to specification.

1.6. Test Facility

Ambient conditions in the laboratory:

Items	Required (IEC 68-1)	Actual
Temperature (°C)	15-35	20-35
Humidity (%RH)	25-75	50-65
Barometric pressure (mbar)	860-1060	950-1000

Site Description:

August 30, 2001 Accreditation on NVLAP
 NVLAP Lab Code: 200347-0



February 23, 1999 Accreditation on DNV
 Statement No. : 413-99-LAB11



January 04, 1999 Accreditation on TUV Rheinland
 Certificate No.: I9865712-9901



April 18, 2001 Accreditation on Nemko
 Certificate No.: ELA 165
 Certificate No.: ELA 162
 Certificate No.: ELA 191



Site Name: Quietek Corporation

Site Address: No.75-1, Wang-Yeh Valley, Yung-Hsing,
 Chiung-Lin, Hsin-Chu County,
 Taiwa, R.O.C.
 TEL : 886-3-592-8858 / FAX : 886-3-592-8859
 E-Mail : service@quietek.com

2. Conducted Emission

2.1. Test Equipment List

The following test equipment are used during the conducted emission test:

Item	Instrument	Manufacturer	Type No./Serial No	Last Cal.	Remark
1	Test Receiver	R & S	ESCS 30/838251/0001	May, 2002	
2	L.I.S.N.	R & S	ESH3-Z5/836679/0023	May, 2002	EUT
3	L.I.S.N.	R & S	ENV 4200/833209/0023	May, 2002	Peripherals
4	Pulse Limiter	R & S	ESH3-Z2	May, 2002	
5	No.4 Shielded Room			N/A	

Note: All equipment upon which need to calibrated are with calibration period of 1 year.

2.2. Test Setup

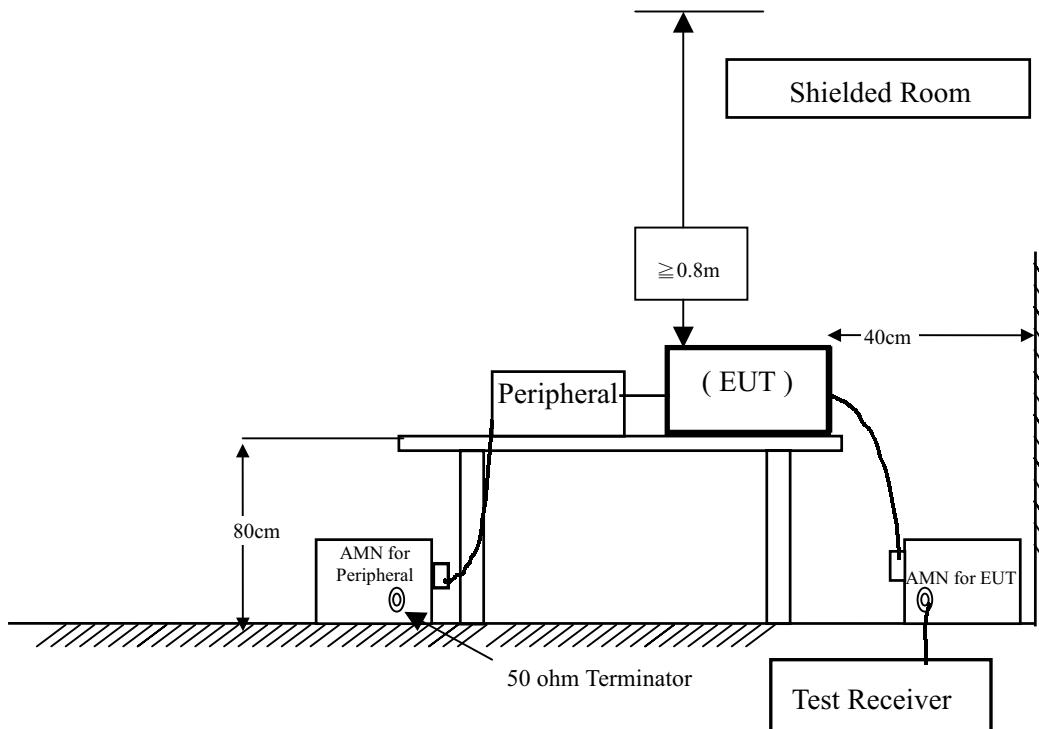

2.3. Limits

FCC Part 15 Paragraph 15.207 (dBuV)		
Frequency MHz	Limits	
	uV	dBuV
0.45 - 30	250	48.0

2.4. Test Procedure

The EUT and simulators are connected to the main power through a line impedance stabilization network (L.I.S.N.). This provides a 50 ohm /50uH coupling impedance for the measuring equipment. The peripheral devices are also connected to the main power through a LISN that provides a 50ohm/50uH coupling impedance with 50ohm termination. (Please refers to the block diagram of the test setup and photographs.)

Both sides of A.C. line are checked for maximum conducted interference. In order to find the maximum emission, the relative positions of equipment and all of the interface cables must be changed according to ANSI C63.4:1992 on conducted measurement.

Conducted emissions were invested over the frequency range from 0.45MHz to 30MHz using a receiver bandwidth of 9kHz.

2.5. Test Result

The emission from the EUT was below the specified limits. The worst-case emissions are shown in [section 6](#). The acceptance criterion was met and the EUT passed the test.

3. Radiated Emission

3.1. Test Equipment

The following test equipment are used during the radiated emission test:

Test Site	Equipment	Manufacturer	Model No./Serial No.	Last Cal.
<input checked="" type="checkbox"/> Site # 1	X Test Receiver	R & S	ESVS 10 / 834468/003	July, 2001
	X Spectrum Analyzer	Advantest	R3162/ 00803480	May, 2002
	X Pre-Amplifier	Advantest	BB525C/ 3307A01812	May, 2002
	X BiconiLog Antenna	Schwarz beck	VU1B9166	July, 2001
	X Bilog Antenna	SCHAFFNER	CBL6112B / 2697	Nov., 2001
<input type="checkbox"/> Site # 2	Test Receiver	R & S	ESCS 30 / 836858/022	Nov., 2001
	Spectrum Analyzer	Advantest	3162 / 100803466	May, 2002
	Pre-Amplifier	Advantest	BB525C/3307A01814	May, 2002
	Bilog Antenna	SCHAFFNER	CBL6112B / 2705	Oct., 2001
	Pre-Amplifier	QTK	QTK-AMP-01/ 0001	July, 2001

- Note:
1. All equipments that need to calibrate are with calibration period of 1 year.
 2. Mark "X" test instruments are used to measure the final test results.

3.2. Test Setup

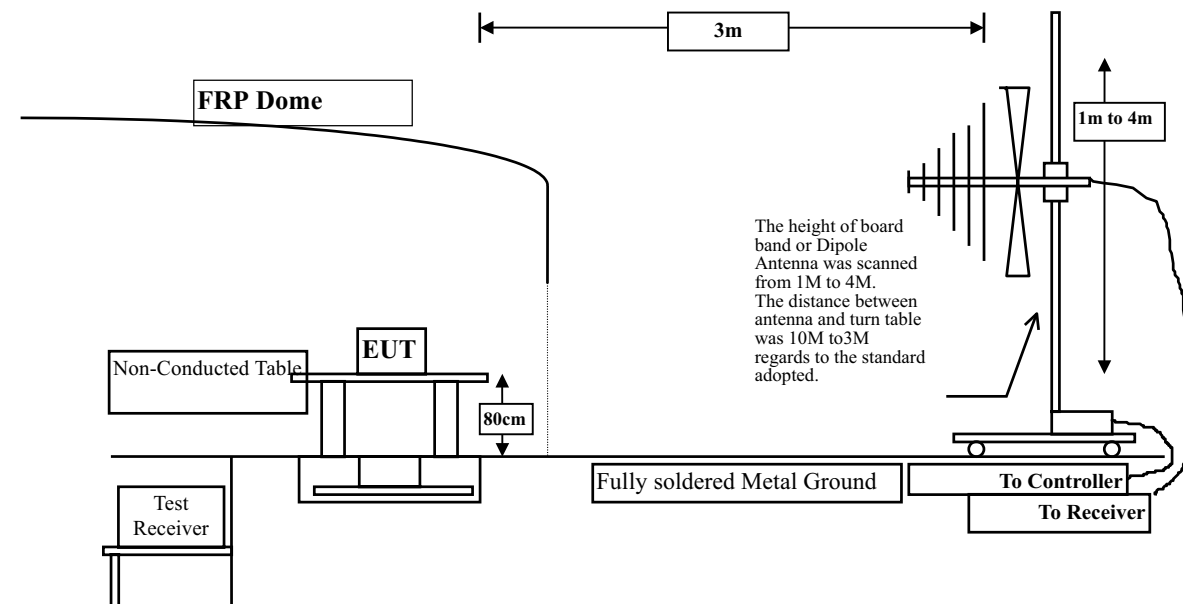

3.3. Limits

➤ FCC Part 15 Subpart C Paragraph 15.227 Limit

Fundamental Frequency MHz	Field strength of fundamental	
	uV/m	dBuV/m
26.96-27.28	10000	80.0

Remarks :

1. RF Voltage (dBuV) = 20 log RF Voltage (uV)
2. Distance refers to the distance in meters between the measuring instrument antenna and the closed point of any part of the device or system.
3. The emission limit in this paragraph is based on measurement instrumentation employing an average detector. Measurement using instrumentation with a peak detector function, corresponding to 20dB above the maximum permitted average limit.

➤ Frequencies in restricted band are complied to limits on Paragraph 15.209.

Frequency MHz	15.209 Limits (dBuV/m @3m)
30-88	40
88-216	43.5
216-960	46
Above 960	54

- Remarks :
1. RF Voltage (dBuV) = 20 log RF Voltage (uV)
 2. In the Above Table, the tighter limit applies at the band edges.
 3. Distance refers to the distance in meters between the measuring instrument antenna and the closed point of any part of the device or system.

3.4. Test Procedure

The EUT and its simulators are placed on a turn table which is 0.8 meter above ground. The turn table can rotate 360 degrees to determine the position of the maximum emission level. The EUT was positioned such that the distance from antenna to the EUT was 3 meters.

The antenna can move up and down between 1 meter and 4 meters to find out the maximum emission level.

Both horizontal and vertical polarization of the antenna are set on measurement. In order to find the maximum emission, all of the interface cables must be manipulated according to ANSI C63.4:1992 on radiated measurement.

Radiated emissions were investigated over the frequency range from 30MHz to 1GHz using a receiver bandwidth of 120kHz. Radiated was performed at an antenna to EUT distance of 3 meters.

The frequency range from 30MHz to 10th harmonics is checked.

3.5. Test Result

The emission from the EUT was below the specified limits. The worst-case emissions are shown in [section 6](#). The acceptance criterion was met and the EUT passed the test.

4. Band Edge

4.1. Test Equipment

The following test equipments are used during the band edge tests:

	Equipment	Manufacturer	Model No./Serial No.	Last Cal.
X	Spectrum Analyzer	Advantest	R3272 / 72421194	May, 2002
X	Test Receiver	R & S	ESCS 30 / 825442/14	May, 2002
X	Spectrum Analyzer	Advantest	R3261C / 71720140	May, 2002
X	Pre-Amplifier	HP	8447D/3307A01812	May, 2002
X	Bilog Antenna	Chase	CBL6112B / 12452	Sep., 2001
X	Horn Antenna	EM	EM6917 / 103325	May, 2002

- Note: 1. All equipments that need to calibrate are with calibration period of 1 year.
 2. Mark "X" test instruments are used to measure the final test results.

4.2. Test Setup

RF Conducted Measurement:

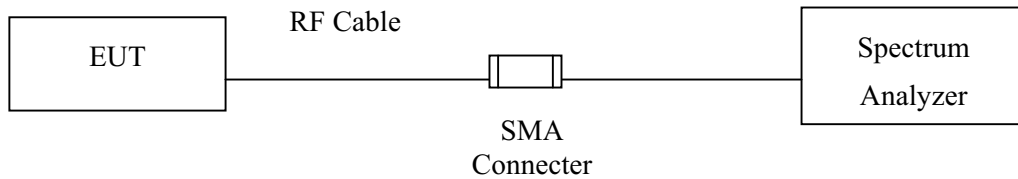

RF Radiated Measurement:

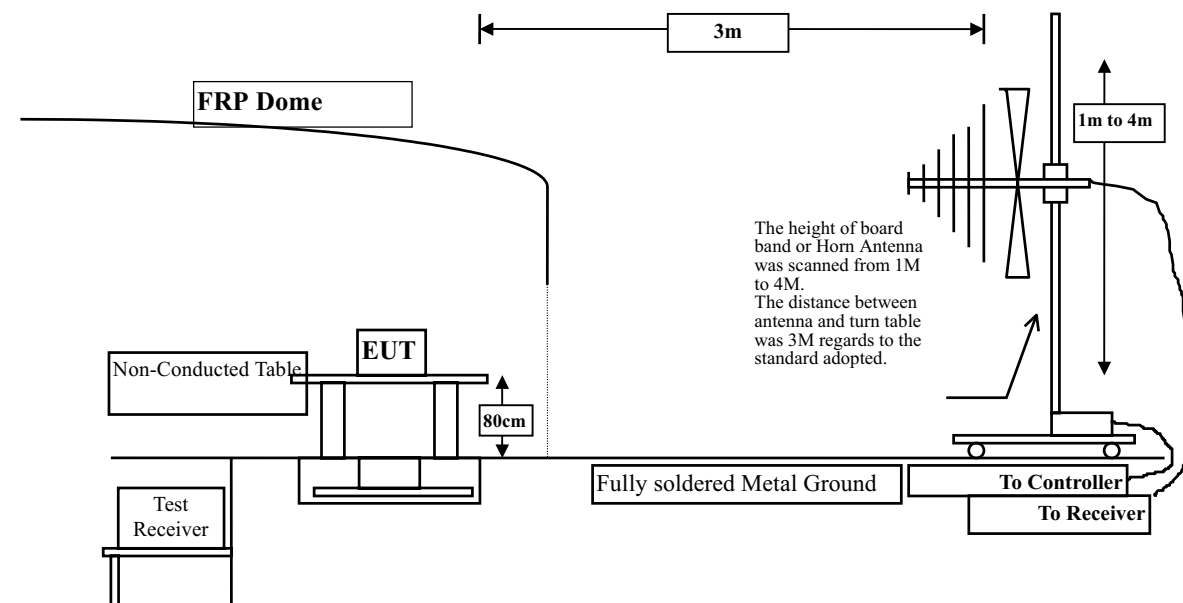

4.3. Limit

Attenuation below the general limits specified in Section 15.209(a) is not required. In addition, radiated emissions which fall in the restricted bands, as defined in Section 15.205(a), must also comply with the radiated emission limits specified in Section 15.209(a) (see Section 15.205(c)).

4.4. Test Procedure

The EUT and its simulators are placed on a turn table which is 0.8 meter above ground. The turn table can rotate 360 degrees to determine the position of the maximum emission level. The EUT was positioned such that the distance from antenna to the EUT was 3 meters.

The antenna can move up and down between 1 meter and 4 meters to find out the maximum emission level.

Both horizontal and vertical polarization of the antenna are set on measurement. In order to find the maximum emission, all of the interface cables must be manipulated according to ANSI C63.4:1992 on radiated measurement.

The additional latch filter below 1GHz was used to measure the level of harmonics radiated emission during field strength of harmonics measurement.

The bandwidth below 30MHz setting on the field strength meter is 10 kHz, above 1GHz are 1 MHz.

4.5. Test Result

The emission from the EUT was below specified limits. The worst-case emissions are shown in section 6. The acceptance criterion was met and the EUT passed the test.

5. EMI Reduction Method During Compliance Testing

No modification was made during testing.

6. Summary of Test Datas

The test results in the emission were performed according to the requirements of measurement standard and process. Quietek Corporation is assumed full responsibility for the accuracy and completeness of these measurements. The test data of the emission is listed as below.

6.1. Test Data of Conducted Emission

Owing to the DC operation of EUT, this test item is not performed.

6.2. Test Data of Radiated Emission

Product : Wireless Keyboard
 Test Item : Fundamental Radiated Emission Data
 Test Site : No.1 OATS
 Test Voltage : DC 3V(Power by Battery)
 Test Mode : Channel 2

Freq.	Cable	Probe	PreAMP	Reading	Emission	Margin	Limit
	Loss	Factor		Level	Level		
MHz	dB	dB/m	dB	dBuV	dBuV/m	dB	dBuV/m
Horizontal (Peak Detector)							
27.140	0.20	4.24	20.70	65.13	48.87	51.13	100.00
Vertical (Peak Detector)							
27.140	0.20	10.41	20.70	72.42	62.33	37.67	100.00

Note:

1. All Readings are Peak value.
2. Emission Level = Reading Level + Probe Factor + Cable loss-PreAMP.
3. The average measurement was not performed when the peak measured data under the limit of average detection.

Product : Wireless Keyboard
 Test Item : General Radiated Emission Data
 Test Site : No.1 OATS
 Test Voltage : DC 3V(Power by Battery)
 Test Mode : Channel 2

Freq.	Cable	Probe	PreAMP	Reading	Emission	Margin	Limit
MHz	Loss	Factor		Level	Level		
	dB	dB/m	dB	dBuV	dBuV/m	dB	dBuV/m

Horizontal

53.980	0.99	6.24	0.00	18.14	25.37	14.63	40.00
*83.540	1.15	8.50	0.00	23.14	32.79	7.21	40.00
134.250	1.41	11.39	0.00	13.50	26.30	17.20	43.50
162.480	1.56	9.19	0.00	15.40	26.15	17.35	43.50
212.520	1.81	7.93	0.00	16.54	26.28	17.22	43.50
308.000	2.30	12.13	0.00	16.24	30.67	15.33	46.00

Vertical

53.960	0.99	5.90	0.00	16.58	23.47	16.53	40.00
*63.490	1.04	6.13	0.00	17.21	24.39	15.61	40.00
112.250	1.29	10.92	0.00	15.34	27.55	15.95	43.50
164.280	1.56	8.47	0.00	14.50	24.53	18.97	43.50
223.485	1.86	9.25	0.00	16.24	27.35	18.65	46.00
342.150	2.47	12.80	0.00	14.29	29.56	16.44	46.00

Note:

1. All Reading Levels below 1GHz are Quasi-Peak, above are peak and average value.
2. “ * ”, means this data is the worst emission level.
3. Emission Level = Reading Level + Probe Factor + Cable loss.

6.3. Test Result of Band Edge

Product : Wireless Keyboard
 Test Item : Band Edge Data
 Test Site : No.1 OATS
 Test Mode : Channel 2

RF Radiated Measurement: (Peak Detector)

Channel No.	Frequency (MHz)	Reading Level (dBuV)	Emission Level (dBuV/m)	Limit (dBuV/m)	Result
2 (Horizontal)	26.950	63.42	47.16	69.5	Pass
2 (Vertical)	26.950	51.15	41.06	69.5	Pass

Figure Channel 2: (Horizontal)

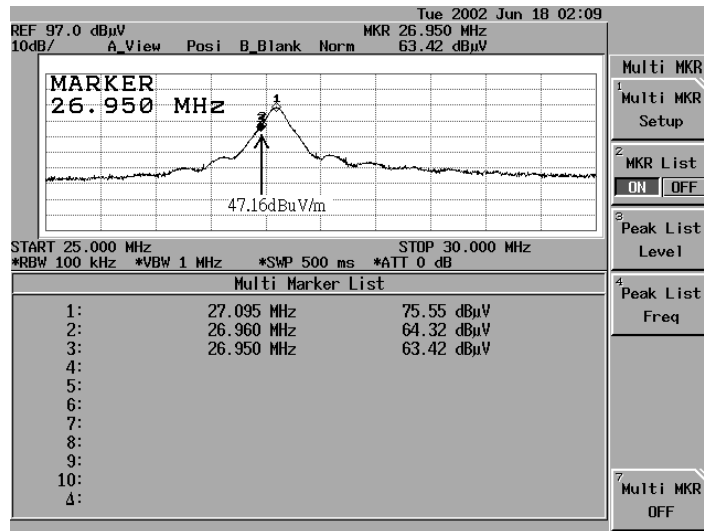
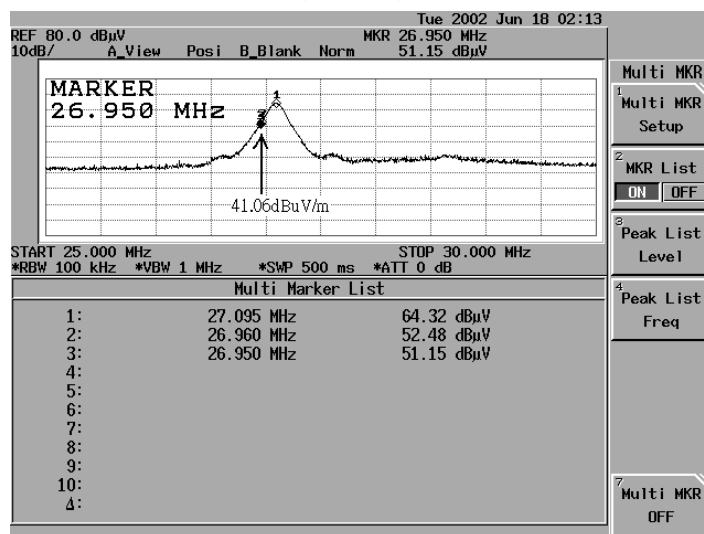

Figure Channel 2: (Vertical)



Note:

1. The average measurement was not performed when the peak measured data under the limit of average detection.

Product : Wireless Keyboard
 Test Item : Band Edge Data
 Test Site : No.1 OATS
 Test Mode : Channel 2

RF Radiated Measurement: (Peak Detector)

Channel No.	Frequency (MHz)	Reading Level (dBuV)	Emission Level (dBuV/m)	Limit (dBuV/m)	Result
2 (Horizontal)	27.290	58.95	42.69	69.5	Pass
2 (Vertical)	27.290	39.43	49.52	69.5	Pass

Figure Channel 2: (Horizontal)

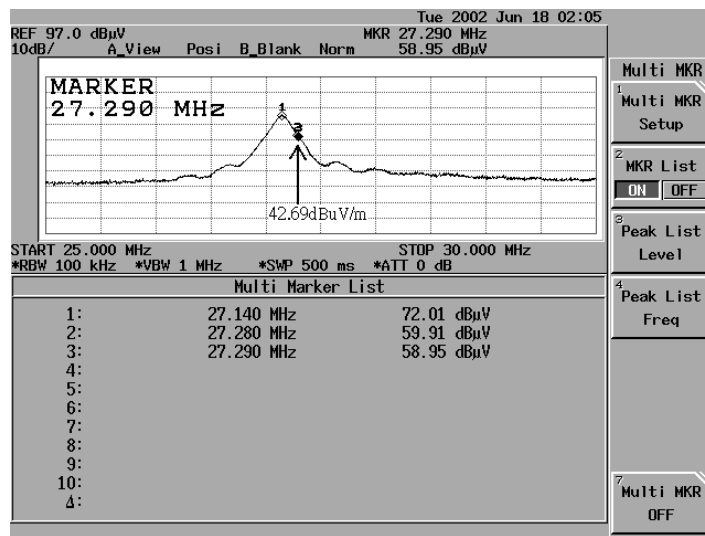
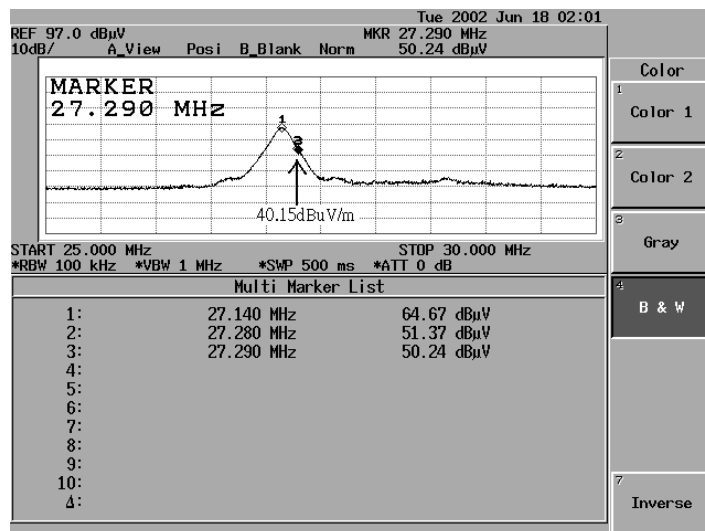

Figure Channel 2: (Vertical)



Note:

1. The average measurement was not performed when the peak measured data under the limit of average detection.

Attachment 1: EUT Test Photographs

Attachment 2: EUT Detailed Photographs