

# TEST REPORT

ACCORDING TO: FCC CFR 47 PART 15 Subpart C, section 15.249 and subpart B

FOR:

**On Track Innovations Ltd.  
Vehicle IDentification unit  
Model:VID (902.1 MHz)**

This report is in conformity with ISO/ IEC 17025. The "A2LA Accredited" symbol endorsement applies only to the tests and calibrations that are listed in the scope of Hermon Laboratories accreditation. The test results relate only to the items tested. This test report shall not be reproduced in any form except in full with the written approval of Hermon Laboratories Ltd.

## Table of contents

1	Applicant information.....	3
2	Equipment under test attributes .....	3
3	Manufacturer information .....	3
4	Test details.....	3
5	Tests summary.....	4
6	EUT description.....	5
6.1	General information.....	5
6.2	Ports and lines .....	5
6.3	Operating frequencies.....	5
6.4	Changes made in the EUT .....	5
6.5	Test configuration.....	6
6.6	Transmitter characteristics .....	7
7	Transmitter tests according to 47CFR part 15 subpart C requirements .....	8
7.1	Field strength of emissions.....	8
7.2	Band edge emission.....	21
7.3	Antenna requirements.....	24
8	Emission tests according to 47CFR part 15 subpart B requirements .....	25
8.1	Radiated emission measurements .....	25
9	APPENDIX A Test equipment and ancillaries used for tests.....	29
10	APPENDIX B Measurement uncertainties.....	30
11	APPENDIX C Test laboratory description .....	31
12	APPENDIX D Specification references .....	31
13	APPENDIX E Abbreviations and acronyms.....	32
14	APPENDIX F Test equipment correction factors.....	33

## 1 Applicant information

**Client name:** On Track Innovations Ltd.  
**Address:** P.O.B. 32, ZHR Industrial Zone, Rosh Pina, Index 12000, Israel  
**Telephone:** +972 4686 8000  
**Fax:** +972 4693 8887  
**E-mail:** h\_itay@otiglobal.com  
**Contact name:** Mr. Hemy Itay

## 2 Equipment under test attributes

**Product name:** Vehicle identification unit of fuel system  
**Product type:** Transceiver  
**Model(s):** VID (902.1 MHz)  
**Hardware version:** 3.22 with a filter  
**Receipt date:** 4/1/2007

## 3 Manufacturer information

**Manufacturer name:** On Track Innovations Ltd.  
**Address:** P.O.B. 32, ZHR Industrial Zone, Rosh Pina, Index 12000, Israel  
**Telephone:** +972 4686 8000  
**Fax:** +972 4693 8887  
**E-Mail:** h\_itay@otiglobal.com  
**Contact name:** Mr. Hemy Itay



## 4 Test details

**Project ID:** 17838  
**Location:** Hermon Laboratories Ltd., Harakevet Industrial Zone, Binyamina 30500, Israel  
**Test started:** 4/1/2007  
**Test completed:** 4/11/2007  
**Test specification(s):** FCC Part 15, subpart C, §15.249 and subpart B

## 5 Tests summary

Test	Status
<b>Transmitter characteristics</b>	
Section 15.249(a), Field strength of fundamental	Pass
Section 15.249(a), Field strength of harmonics	Pass
Section 15.249(d), Field strength of spurious other than harmonics	Pass
Section 15.249(d), Band edge emissions	Pass
Section 15.203, Antenna requirement	Pass
Section 15.207(a), Conducted emission	Not required
<b>Unintentional emissions</b>	
Section 15.107, Conducted emission at AC power port	Not required
Section 15.109, Radiated emission	Pass
Section 15.111, Conducted emission at receiver antenna port	Not required

Testing was completed against all relevant requirements of the test standard. The results obtained indicate that the product under test complies in full with the requirements tested.  
The test results relate only to the items tested. Pass/ fail decision was based on nominal values.

	Name and Title	Date	Signature
<b>Tested by:</b>	Mr. A. Lane, test engineer	April 11, 2007	
<b>Reviewed by:</b>	Mrs. M. Cherniavsky, certification engineer	May 10, 2007	
<b>Approved by:</b>	Mr. M. Nikishin, EMC and Radio group leader	May 11, 2007	



## 6 EUT description

### 6.1 General information

The EUT, vehicle identification unit, is a part of Easy Fuel System, mounted inside a vehicle and powered from 12 VDC vehicle battery. It includes 13.56 MHz receiver with an external loop antenna mounted around fueling inlet and 902.1 transceiver with an external antenna mounted onto window.

### 6.2 Ports and lines

Port type	Port description	Connected		Connector type	Qty.	Cable type	Cable length
		From	To				
Power	12 VDC	EUT	Battery	Terminal block	1	Unshielded	10 m
IF	Loop antenna	EUT	Loop antenna	Terminal block	1	Shielded	0.3 m
RF	Antenna	EUT	Antenna	SMA	1	Coaxial	1 m

### 6.3 Operating frequencies

Source	Frequency, MHz
Clock	8
Rx	13.56
LO	14.74   24.26
Tx/Rx	902.1

### 6.4 Changes made in the EUT

To provide operation at 902.1 MHz only, a serial SAW filter was inserted (instead of a serial zero ohm resistor) in the receiving pass of the transceiver in order to enhance its rejection of the higher frequencies (for operation in environment reach with RFID interfering system).

## 6.5 Test configuration

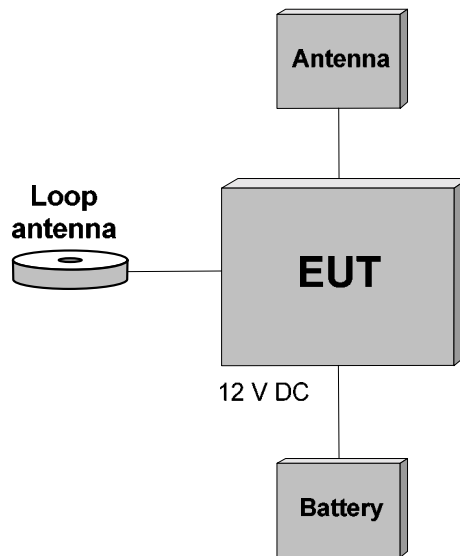



## 6.6 Transmitter characteristics

<b>Type of equipment</b>							
<input checked="" type="checkbox"/>	Stand-alone (Equipment with or without its own control provisions)						
	Combined equipment (Equipment where the radio part is fully integrated within another type of equipment)						
	Plug-in card (Equipment intended for a variety of host systems)						
<b>Intended use</b>		<b>Condition of use</b>					
	Fixed	Always at a distance more than 2 m from all people					
<input checked="" type="checkbox"/>	mobile	Always at a distance more than 20 cm from all people					
	portable	May operate at a distance closer than 20 cm to human body					
<b>Assigned frequency range</b>		902 - 928 MHz					
<b>Operating frequency range</b>		902.1 MHz					
<b>Maximum rated output power</b>		Equivalent isotropically radiated power		-3.43 dBm			
<b>Is transmitter output power variable?</b>		<input checked="" type="checkbox"/> No					
		<input type="checkbox"/> Yes				continuous variable	
						stepped variable with stepsize	
						minimum RF power	
						maximum RF power	
<b>Antenna connection</b>							
<input type="checkbox"/> unique coupling	<input checked="" type="checkbox"/>	standard connector		<input type="checkbox"/> Integral	<input checked="" type="checkbox"/> with temporary RF connector <input type="checkbox"/> without temporary RF connector		
<b>Antenna/s technical characteristics</b>							
Type	Manufacturer		Model number		Gain		
Window mounted antenna	Chipcon		NA		0 dBi		
<b>Transmitter 99% power bandwidth</b>		50 kHz					
<b>Transmitter aggregate data rate/s</b>		9.6 Mbps					
<b>Type of modulation</b>		FSK					
<b>Type of multiplexing</b>		TDMA					
<b>Maximum transmitter duty cycle in normal use</b>		5%	<b>Tx ON time</b>	40 msec	<b>Period</b>	800 msec	
<b>Transmitter duty cycle supplied for test</b>		100%					
<b>Transmitter power source</b>							
	Battery	<b>Nominal rated voltage</b>		Battery type			
<input checked="" type="checkbox"/>	DC	12 V DC					
	AC mains	<b>Nominal rated voltage</b>		Frequency			
<b>Common power source for transmitter and receiver</b>			<input checked="" type="checkbox"/>	yes	no		

<b>Test specification:</b>	<b>Section 15.249(a), Field strength of emissions</b>		
<b>Test procedure:</b>	ANSI C63.4, Section 13.1.4		
<b>Test mode:</b>	Compliance	<b>Verdict:</b>	<b>PASS</b>
<b>Date &amp; Time:</b>	4/11/2007 2:34:52 PM		
<b>Temperature:</b> 25°C	<b>Air Pressure:</b> 1010 hPa	<b>Relative Humidity:</b> 30 %	<b>Power Supply:</b> 12 V DC
<b>Remarks:</b>			

## 7 Transmitter tests according to 47CFR part 15 subpart C requirements

### 7.1 Field strength of emissions

#### 7.1.1 General

This test was performed to measure field strength of fundamental and spurious emissions from the EUT. Specification test limits are given in Table 7.1.1, Table 7.1.2, Table 7.1.3.

Table 7.1.1 Radiated fundamental emission limits

Fundamental frequency, MHz	Field strength at 3 m, dB(μV/m)	
	Quasi-peak	
902 – 928	94.0	

Table 7.1.2 Harmonics limits

Fundamental frequency, MHz	Field strength at 3 m, dB(μV/m)	
	Peak	Average
902 – 928	74.0	54.0

Table 7.1.3 Radiated spurious emissions limits

Frequency, MHz	Field strength at 3 m, dB(μV/m)*			Attenuation below carrier
	Peak	Quasi Peak	Average	
0.009 – 0.090	148.5 – 128.5	NA	128.5 – 108.5**	50 dBc (whichever is the less stringent)
0.090 – 0.110	NA	108.5 – 106.8**	NA	
0.110 – 0.490	126.8 – 113.8	NA	106.8 – 93.8**	
0.490 – 1.705	NA	73.8 – 63.0**	NA	
1.705 – 30.0*		69.5		
30 – 88		40.0		
88 – 216		43.5		
216 – 960		46.0		
960 - 1000	54.0			
Above 1000	74.0	NA	54.0	

\*- The limit for 3 m test distance was calculated using the inverse square distance extrapolation factor as follows:

$$\text{Lim}_{S_2} = \text{Lim}_{S_1} + 40 \log(S_1/S_2),$$

where  $S_1$  and  $S_2$  – standard defined and test distance respectively in meters.

\*\*- The limit decreases linearly with the logarithm of frequency.

Note: The above field strength limits applied from the lowest radio frequency generated in the device, without going below 9 kHz up to the tenth harmonic of the highest fundamental frequency but not exceeding 40 GHz for intentional radiators operated below 10 GHz and up to the fifth harmonic of the highest fundamental frequency but not exceeding 100 GHz for intentional radiators operated above 10 GHz.



<b>Test specification:</b>		<b>Section 15.249(a), Field strength of emissions</b>	
<b>Test procedure:</b>		ANSI C63.4, Section 13.1.4	
<b>Test mode:</b>	Compliance	<b>Verdict:</b>	PASS
<b>Date &amp; Time:</b>	4/11/2007 2:34:52 PM		
<b>Temperature:</b> 25°C	<b>Air Pressure:</b> 1010 hPa	<b>Relative Humidity:</b> 30 %	<b>Power Supply:</b> 12 V DC
<b>Remarks:</b>			

**7.1.2 Test procedure for spurious emission field strength measurements in 9 kHz to 30 MHz band**

7.1.2.1 The EUT was set up as shown in Figure 7.1.1, energized and the performance check was conducted.

7.1.2.2 The specified frequency range was investigated with antenna connected to spectrum analyzer/ EMI receiver. To find maximum radiation the turntable was rotated 360° and the measuring antenna was rotated around its vertical axis.

7.1.2.3 The worst test results (the lowest margins) were recorded in Table 7.1.4, Table 7.1.6 and shown in the associated plots.

**7.1.3 Test procedure for spurious emission field strength measurements above 30 MHz**

7.1.3.1 The EUT was set up as shown in Figure 7.1.2, energized and the performance check was conducted.

7.1.3.2 The specified frequency range was investigated with antenna connected to spectrum analyzer/ EMI receiver. To find maximum radiation the turntable was rotated 360°, the measuring antenna height was changed from 1 to 4 m, its polarization was switched from vertical to horizontal.

7.1.3.3 The worst test results (the lowest margins) were recorded in Table 7.1.4, Table 7.1.6 and shown in the associated plots.

**Figure 7.1.1 Setup for spurious emission field strength measurements below 30 MHz**

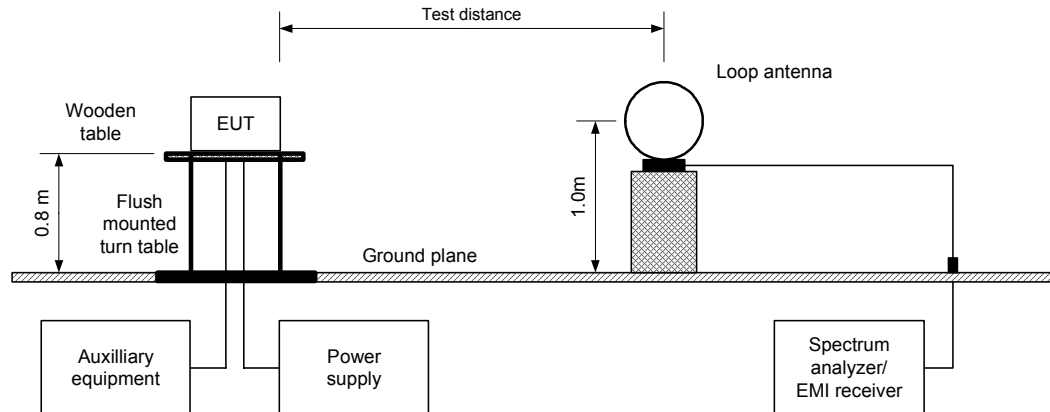

<b>Test specification:</b> Section 15.249(a), Field strength of emissions			
<b>Test procedure:</b> ANSI C63.4, Section 13.1.4			
<b>Test mode:</b> Compliance		<b>Verdict:</b> PASS	
<b>Date &amp; Time:</b> 4/11/2007 2:34:52 PM			
<b>Temperature:</b> 25°C	<b>Air Pressure:</b> 1010 hPa	<b>Relative Humidity:</b> 30 %	<b>Power Supply:</b> 12 V DC
<b>Remarks:</b>			

Figure 7.1.2 Setup for spurious emission field strength measurements above 30 MHz

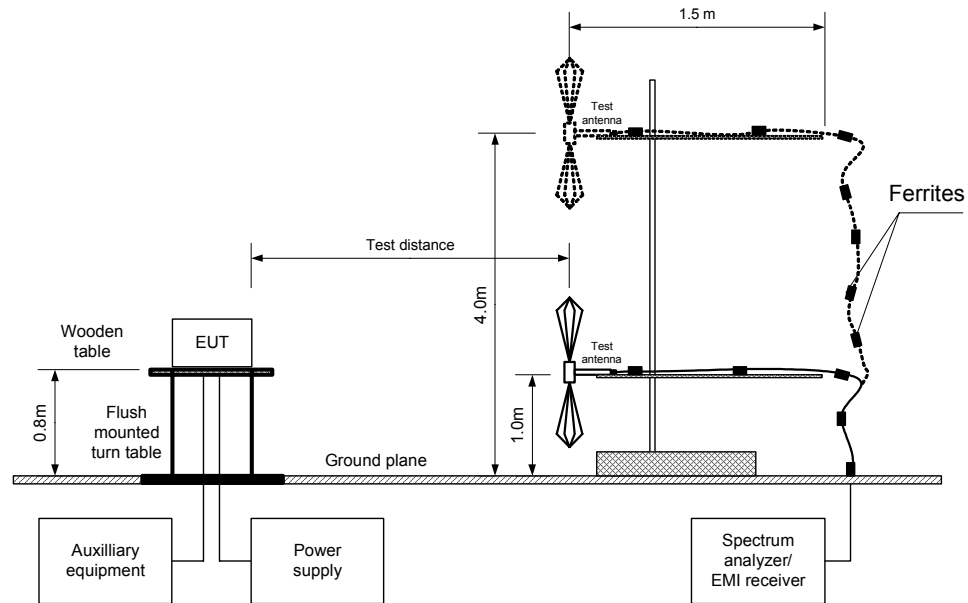

<b>Test specification:</b>		<b>Section 15.249(a), Field strength of emissions</b>	
<b>Test procedure:</b>		ANSI C63.4, Section 13.1.4	
<b>Test mode:</b>	Compliance	<b>Verdict:</b>	PASS
<b>Date &amp; Time:</b>	4/11/2007 2:34:52 PM		
<b>Temperature:</b> 25°C	<b>Air Pressure:</b> 1010 hPa	<b>Relative Humidity:</b> 30 %	<b>Power Supply:</b> 12 V DC
<b>Remarks:</b>			

**Table 7.1.4 Field strength of fundamental emission, spurious emissions outside restricted bands and within restricted bands at frequencies above 1 GHz**

TEST DISTANCE:	3 m
EUT POSITION:	Typical
MODULATION:	FSK
MODULATING SIGNAL:	ID code
TRANSMITTER OUTPUT POWER SETTINGS:	Maximum
INVESTIGATED FREQUENCY RANGE:	0.009 - 10000 MHz
DETECTOR USED:	Peak
RESOLUTION BANDWIDTH:	1 kHz (9 kHz – 150 kHz) 9.0 kHz (150 kHz – 30 MHz) 120 kHz (30 MHz – 1000 MHz) 1.0 MHz (above 1000 MHz)
VIDEO BANDWIDTH:	≥ Resolution bandwidth
TEST ANTENNA TYPE:	Active loop (9 kHz – 30 MHz) Biconilog (30 MHz – 1000 MHz) Double ridged guide (above 1000 MHz)

Frequency, MHz	Peak emission, dB(μV/m)	Quasi-peak			Antenna polarization	Antenna height, m	Turn-table position*, degrees	Verdict
		Measured emission, dB(μV/m)	Limit, dB(μV/m)	Margin, dB**				
<b>Fundamental emission</b>								Pass
902.1	92.00	91.80	94.00	-2.20	Vertical	1.3	0	

F, MHz	Antenna		Azimuth, degrees*	Peak field strength			Avr factor, dB	Average field strength			Verdict
	Pol.	Height, m		Measured, dB(μV/m)	Limit, dB(μV/m)	Margin, dB**		Measured, dB(μV/m)	Limit, dB(μV/m)	Margin, dB**	
<b>Spurious emissions</b>											Pass
All spurious are 20 dB below peak limit											

\*- EUT front panel refers to 0 degrees position of turntable.  
\*\*- Margin = dB below (negative if above) specification limit.

**Table 7.1.5 Average factor calculation**

Transmission pulse		Transmission burst		Transmission train duration, ms	Average factor, dB
Duration, ms	Period, ms	Duration, ms	Period, ms		
Duty cycle 100%					0

\*- Average factor was calculated as follows

for pulse train shorter than 100 ms: 
$$\text{Average factor} = 20 \times \log_{10} \left( \frac{\text{Pulse duration}}{\text{Pulse period}} \times \frac{\text{Burst duration}}{\text{Train duration}} \times \text{Number of bursts within pulse train} \right)$$

for pulse train longer than 100 ms: 
$$\text{Average factor} = 20 \times \log_{10} \left( \frac{\text{Pulse duration}}{\text{Pulse period}} \times \frac{\text{Burst duration}}{100 \text{ ms}} \times \text{Number of bursts within 100 ms} \right)$$

**Reference numbers of test equipment used**

HL 0410	HL 0446	HL 0465	HL 0521	HL 0589	HL 0592	HL 0593	HL 0594
HL 0604	HL 1200	HL 1947	HL 1984	HL 2259	HL 2387	HL 2697	HL 2909
HL 2910							

Full description is given in Appendix A.

<b>Test specification:</b>		<b>Section 15.249(a), Field strength of emissions</b>	
<b>Test procedure:</b>		ANSI C63.4, Section 13.1.4	
<b>Test mode:</b>	Compliance	<b>Verdict:</b>	<b>PASS</b>
<b>Date &amp; Time:</b>	4/11/2007 2:34:52 PM		
<b>Temperature:</b> 25°C	<b>Air Pressure:</b> 1010 hPa	<b>Relative Humidity:</b> 30 %	<b>Power Supply:</b> 12 V DC
<b>Remarks:</b>			

**Table 7.1.6 Field strength of emissions below 1 GHz within restricted bands**

TEST DISTANCE: 3 m  
 EUT POSITION: Typical  
 MODULATION: FSK  
 MODULATING SIGNAL: ID code  
 TRANSMITTER OUTPUT POWER SETTINGS: Maximum  
 INVESTIGATED FREQUENCY RANGE: 0.009 – 1000 MHz  
 DETECTOR USED: Peak  
 RESOLUTION BANDWIDTH: 1 kHz (9 kHz – 150 kHz)  
 9.0 kHz (150 kHz – 30 MHz)  
 120 kHz (30 MHz – 1000 MHz)  
 VIDEO BANDWIDTH: ≥ Resolution bandwidth  
 TEST ANTENNA TYPE: Active loop (9 kHz – 30 MHz)  
 Biconilog (30 MHz – 1000 MHz)

Frequency, MHz	Peak emission, dB(μV/m)	Quasi-peak			Antenna polarization	Antenna height, m	Turn-table position**, degrees	Verdict
		Measured emission, dB(μV/m)	Limit, dB(μV/m)	Margin, dB*				
No spurious were found								Pass

\*- Margin = Measured emission - specification limit.

\*\* - EUT front panel refer to 0 degrees position of turntable.

**Table 7.1.7 Restricted bands**

MHz	MHz	MHz	MHz	MHz	GHz
0.09 - 0.11	8.37625 - 8.38675	73 - 74.6	399.9 - 410	2690 - 2900	10.6 - 12.7
0.495 - 0.505	8.41425 - 8.41475	74.8 - 75.2	608 - 614	3260 - 3267	13.25 - 13.4
2.1735 - 2.1905	12.29 - 12.293	108 - 121.94	960 - 1240	3332 - 3339	14.47 - 14.5
4.125 - 4.128	12.51975 - 12.52025	123 - 138	1300 - 1427	3345.8 - 3358	15.35 - 16.2
4.17725 - 4.17775	12.57675 - 12.57725	149.9 - 150.05	1435 - 1626.5	3600 - 4400	17.7 - 21.4
4.20725 - 4.20775	13.36 - 13.41	156.52475 - 156.52525	1645.5 - 1646.5	4500 - 5150	22.01 - 23.12
6.215 - 6.218	16.42 - 16.423	156.7 - 156.9	1660 - 1710	5350 - 5460	23.6 - 24
6.26775 - 6.26825	16.69475 - 16.69525	162.0125 - 167.17	1718.8 - 1722.2	7250 - 7750	31.2 - 31.8
6.31175 - 6.31225	16.80425 - 16.80475	167.72 - 173.2	2200 - 2300	8025 - 8500	36.43 - 36.5
8.291 - 8.294	25.5 - 25.67	240 - 285	2310 - 2390	9000 - 9200	Above 38.6
8.362 - 8.366	37.5 - 38.25	322 - 335.4	2483.5 - 2500	9300 - 9500	

**Reference numbers of test equipment used**

HL 0521	HL 0589	HL 0604				
---------	---------	---------	--	--	--	--

Full description is given in Appendix A.

<b>Test specification:</b> Section 15.249(a), Field strength of emissions			
<b>Test procedure:</b> ANSI C63.4, Section 13.1.4			
<b>Test mode:</b> Compliance	<b>Verdict:</b> PASS		
<b>Date &amp; Time:</b> 4/11/2007 2:34:52 PM			
<b>Temperature:</b> 25°C	<b>Air Pressure:</b> 1010 hPa	<b>Relative Humidity:</b> 30 %	<b>Power Supply:</b> 12 V DC
<b>Remarks:</b>			

**Plot 7.1.1 Radiated emission measurements at the fundamental frequency**

TEST SITE: Semi anechoic chamber  
TEST DISTANCE: 3 m  
ANTENNA POLARIZATION: Vertical  
EUT POSITION: Typical

14:23:10 APR 01, 2007

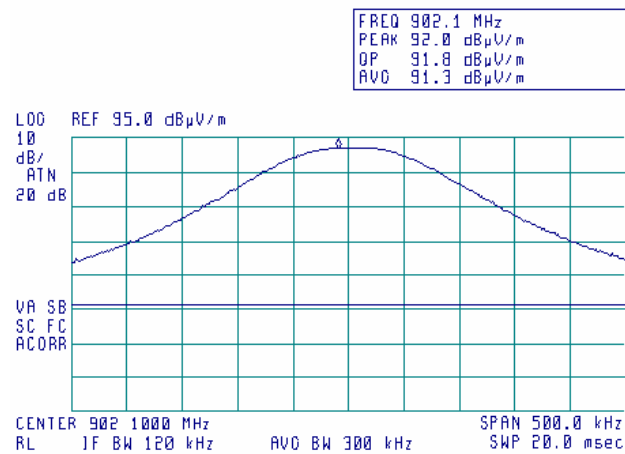

**Plot 7.1.2 Radiated emission measurements at the fundamental frequency**

TEST SITE: Semi anechoic chamber  
TEST DISTANCE: 3 m  
ANTENNA POLARIZATION: Horizontal  
EUT POSITION: Typical

14:28:29 APR 01, 2007

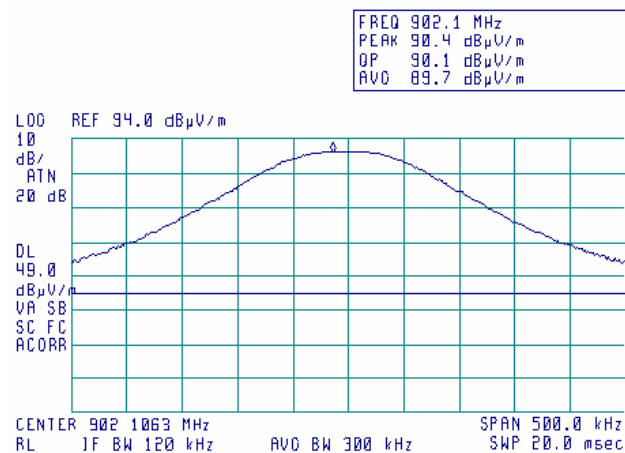

<b>Test specification:</b>	<b>Section 15.249(a), Field strength of emissions</b>		
<b>Test procedure:</b>	ANSI C63.4, Section 13.1.4		
<b>Test mode:</b>	Compliance	<b>Verdict:</b>	<b>PASS</b>
<b>Date &amp; Time:</b>	4/11/2007 2:34:52 PM		
<b>Temperature:</b> 25°C	<b>Air Pressure:</b> 1010 hPa	<b>Relative Humidity:</b> 30 %	<b>Power Supply:</b> 12 V DC
<b>Remarks:</b>			

**Plot 7.1.3 Radiated emission measurements from 9 to 150 kHz**

TEST SITE: Anechoic chamber  
 TEST DISTANCE: 3 m  
 ANTENNA POLARIZATION: Vertical  
 EUT POSITION: Typical

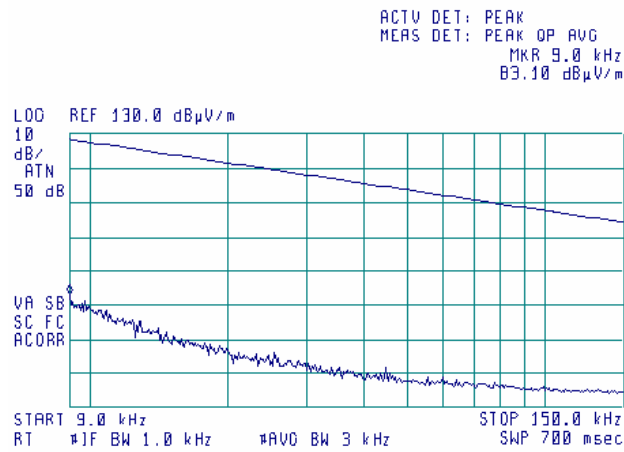

**Plot 7.1.4 Radiated emission measurements from 0.15 to 30 MHz**

TEST SITE: Anechoic chamber  
 TEST DISTANCE: 3 m  
 ANTENNA POLARIZATION: Vertical  
 EUT POSITION: Typical

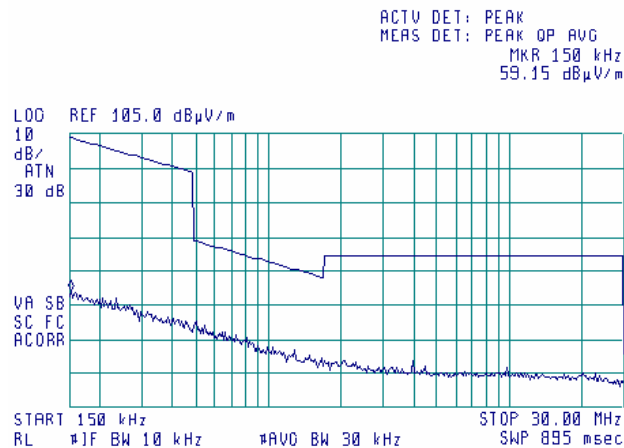

<b>Test specification:</b>	<b>Section 15.249(a), Field strength of emissions</b>		
<b>Test procedure:</b>	ANSI C63.4, Section 13.1.4		
<b>Test mode:</b>	Compliance	<b>Verdict:</b>	<b>PASS</b>
<b>Date &amp; Time:</b>	4/11/2007 2:34:52 PM		
<b>Temperature:</b> 25°C	<b>Air Pressure:</b> 1010 hPa	<b>Relative Humidity:</b> 30 %	<b>Power Supply:</b> 12 V DC
<b>Remarks:</b>			

**Plot 7.1.5 Radiated emission measurements from 30 to 1000 MHz**

TEST SITE: Semi anechoic chamber  
TEST DISTANCE: 3 m  
ANTENNA POLARIZATION: Vertical and Horizontal  
EUT POSITION: Typical

14:30:43 APR 01, 2007

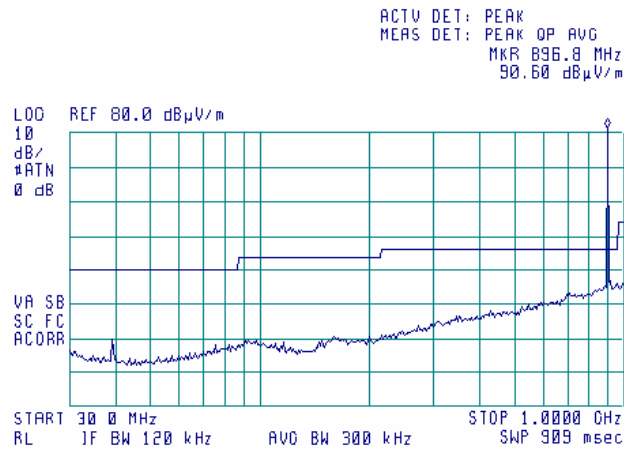

**Plot 7.1.6 Radiated emission measurements from 1.0 to 2.9 GHz**

TEST SITE: Anechoic chamber  
TEST DISTANCE: 3 m  
ANTENNA POLARIZATION: Vertical and Horizontal  
EUT POSITION: Typical

14:30:43 APR 01, 2007

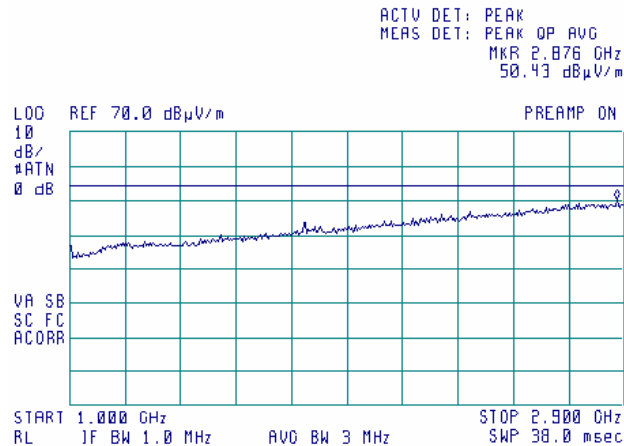

<b>Test specification:</b>	<b>Section 15.249(a), Field strength of emissions</b>		
<b>Test procedure:</b>	ANSI C63.4, Section 13.1.4		
<b>Test mode:</b>	Compliance	<b>Verdict:</b>	<b>PASS</b>
<b>Date &amp; Time:</b>	4/11/2007 2:34:52 PM		
<b>Temperature:</b> 25°C	<b>Air Pressure:</b> 1010 hPa	<b>Relative Humidity:</b> 30 %	<b>Power Supply:</b> 12 V DC
<b>Remarks:</b>			

**Plot 7.1.7 Radiated emission measurements from 2.9 to 10.0 GHz**

TEST SITE: Anechoic chamber  
 TEST DISTANCE: 3 m  
 ANTENNA POLARIZATION: Vertical and Horizontal  
 EUT POSITION: Typical

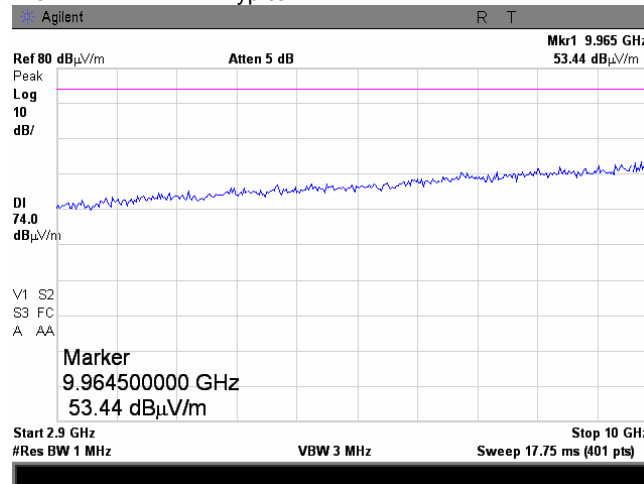



<b>Test specification:</b>	<b>Section 15.249(a), Field strength of emissions</b>		
<b>Test procedure:</b>	ANSI C63.4, Section 13.1.4		
<b>Test mode:</b>	Compliance	<b>Verdict:</b>	<b>PASS</b>
<b>Date &amp; Time:</b>	4/11/2007 2:34:52 PM		
<b>Temperature:</b> 25°C	<b>Air Pressure:</b> 1010 hPa	<b>Relative Humidity:</b> 30 %	<b>Power Supply:</b> 12 V DC
<b>Remarks:</b>			

**Plot 7.1.8 Radiated emission measurements at the second harmonic frequency**

TEST SITE: Semi anechoic chamber  
 TEST DISTANCE: 3 m  
 ANTENNA POLARIZATION: Vertical & Horizontal  
 EUT POSITION: Typical

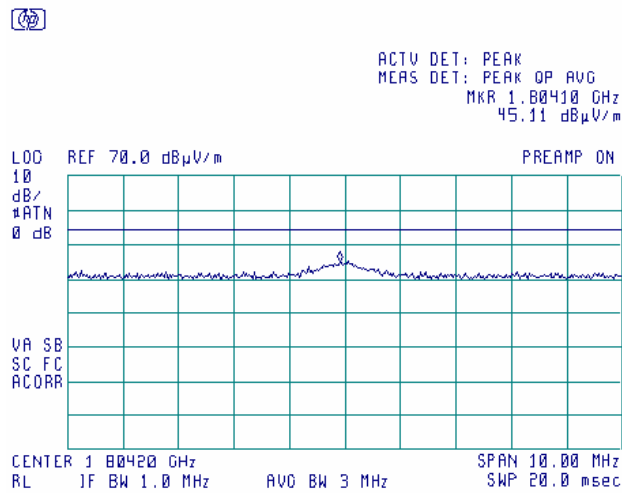

**Plot 7.1.9 Radiated emission measurements at the third harmonic frequency**

TEST SITE: OATS  
 TEST DISTANCE: 3 m  
 ANTENNA POLARIZATION: Vertical & Horizontal  
 EUT POSITION: Typical

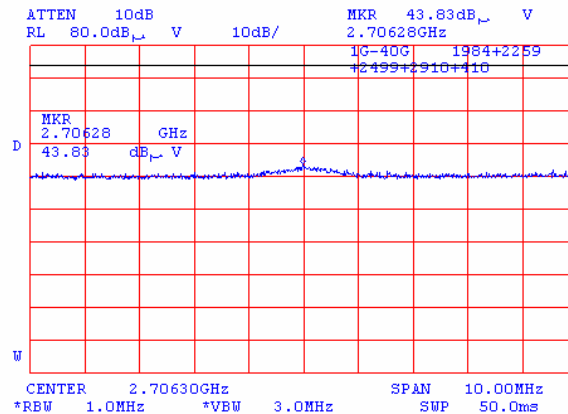

<b>Test specification:</b>	<b>Section 15.249(a), Field strength of emissions</b>		
<b>Test procedure:</b>	ANSI C63.4, Section 13.1.4		
<b>Test mode:</b>	Compliance	<b>Verdict:</b>	<b>PASS</b>
<b>Date &amp; Time:</b>	4/11/2007 2:34:52 PM		
<b>Temperature:</b> 25°C	<b>Air Pressure:</b> 1010 hPa	<b>Relative Humidity:</b> 30 %	<b>Power Supply:</b> 12 V DC
<b>Remarks:</b>			

**Plot 7.1.10 Radiated emission measurements at the fourth harmonic frequency**

TEST SITE: OATS  
 TEST DISTANCE: 3 m  
 ANTENNA POLARIZATION: Vertical & Horizontal  
 EUT POSITION: Typical

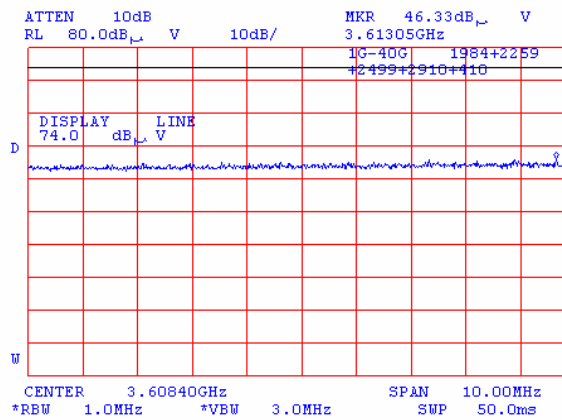

**Plot 7.1.11 Radiated emission measurements at the fifth harmonic frequency**

TEST SITE: Semi anechoic chamber  
 TEST DISTANCE: 3 m  
 ANTENNA POLARIZATION: Vertical & Horizontal  
 EUT POSITION: Typical  
 DETECTOR: Peak

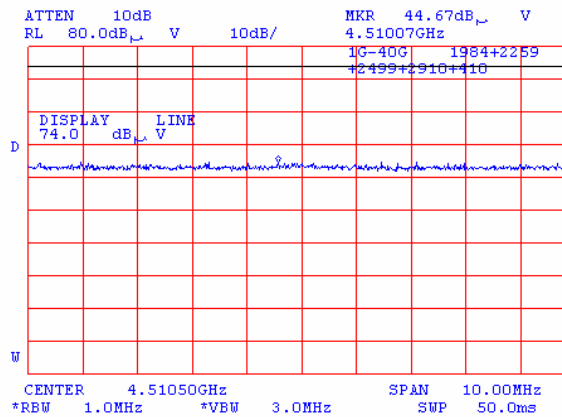

<b>Test specification:</b> Section 15.249(a), Field strength of emissions			
<b>Test procedure:</b> ANSI C63.4, Section 13.1.4			
<b>Test mode:</b> Compliance	<b>Verdict:</b> PASS		
<b>Date &amp; Time:</b> 4/11/2007 2:34:52 PM			
<b>Temperature:</b> 25°C	<b>Air Pressure:</b> 1010 hPa	<b>Relative Humidity:</b> 30 %	<b>Power Supply:</b> 12 V DC
<b>Remarks:</b>			

**Plot 7.1.12 Radiated emission measurements at the sixth harmonic frequency**

TEST SITE: Semi anechoic chamber  
 TEST DISTANCE: 3 m  
 ANTENNA POLARIZATION: Vertical & Horizontal  
 EUT POSITION: Typical  
 DETECTOR: Peak

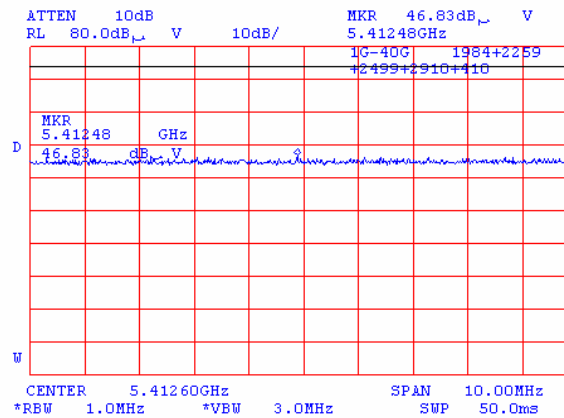

**Plot 7.1.13 Radiated emission measurements at the seventh harmonic frequency**

TEST SITE: Semi anechoic chamber  
 TEST DISTANCE: 3 m  
 ANTENNA POLARIZATION: Vertical & Horizontal  
 EUT POSITION: Typical  
 DETECTOR: Peak

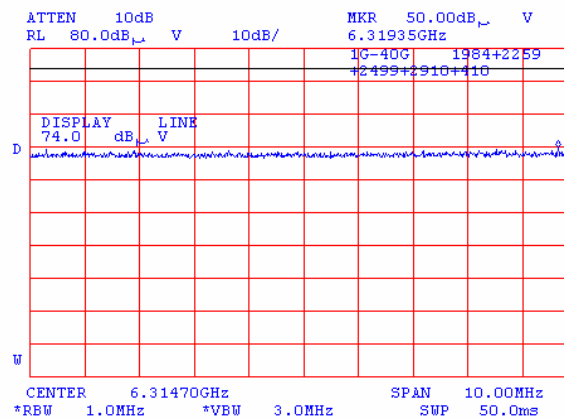

<b>Test specification:</b>	<b>Section 15.249(a), Field strength of emissions</b>		
<b>Test procedure:</b>	ANSI C63.4, Section 13.1.4		
<b>Test mode:</b>	Compliance	<b>Verdict: PASS</b>	
<b>Date &amp; Time:</b>	4/11/2007 2:34:52 PM		
<b>Temperature:</b> 25°C	<b>Air Pressure:</b> 1010 hPa	<b>Relative Humidity:</b> 30 %	<b>Power Supply:</b> 12 V DC
<b>Remarks:</b>			

Plot 7.1.14 Transmission pulse duration

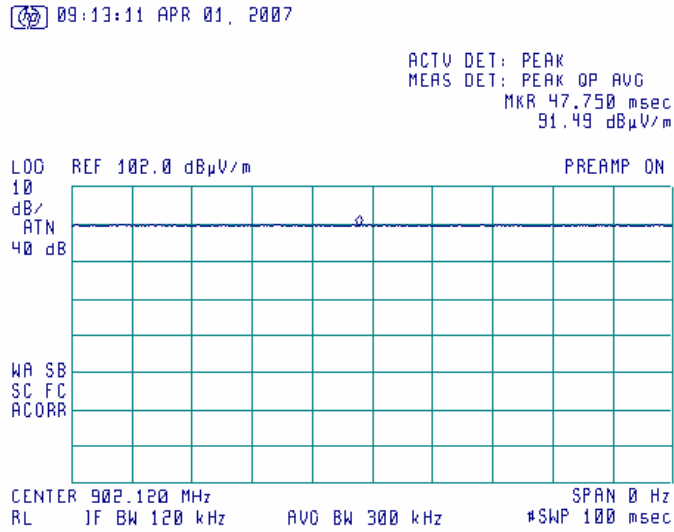

<b>Test specification:</b>		<b>Section 15.249(d), Band edge emissions</b>	
<b>Test procedure:</b>		ANSI C63.4, Section 13.1.4	
<b>Test mode:</b>	Compliance	<b>Verdict:</b>	PASS
<b>Date &amp; Time:</b>	4/5/2007 1:57:47 PM		
<b>Temperature:</b> 23°C	<b>Air Pressure:</b> 1007 hPa	<b>Relative Humidity:</b> 42 %	<b>Power Supply:</b> 12 V DC
<b>Remarks:</b>			

## 7.2 Band edge emission

### 7.2.1 General

This test was performed to verify the EUT band edge emission including all associated side bands and was attenuated at least 50 dB below the unmodulated carrier level or below the general spurious emission limit. Specification test limits are given in Table 7.2.1.

Table 7.2.1 Band edge emission limits

Frequency band, MHz	Field strength limit at 3 m, dB $\mu$ V/m	Attenuation below carrier, dBc	Field strength limit at 50dBc, dB $\mu$ V/m
	Quasi-peak		
902 - 928	46	50	41.8

### 7.2.2 Test procedure

7.2.2.1 The EUT was set up as shown in Figure 7.2.1, energized and the performance check was conducted.

7.2.2.2 The spectrum analyzer frequency span was set to capture all major modulation sidebands of emission and sweep time was set sufficiently slow to ensure peak measurements. Spectrum analyzer was set in peak hold mode and time sufficient for trace stabilization was allowed.

7.2.2.3 The frequency of modulation envelope points beyond which power level drops below the band edge emission limit was measured.

7.2.2.4 The test results were recorded in Table 7.2.2 and shown in the associated plots.

Figure 7.2.1 Band edge emission measurement set up

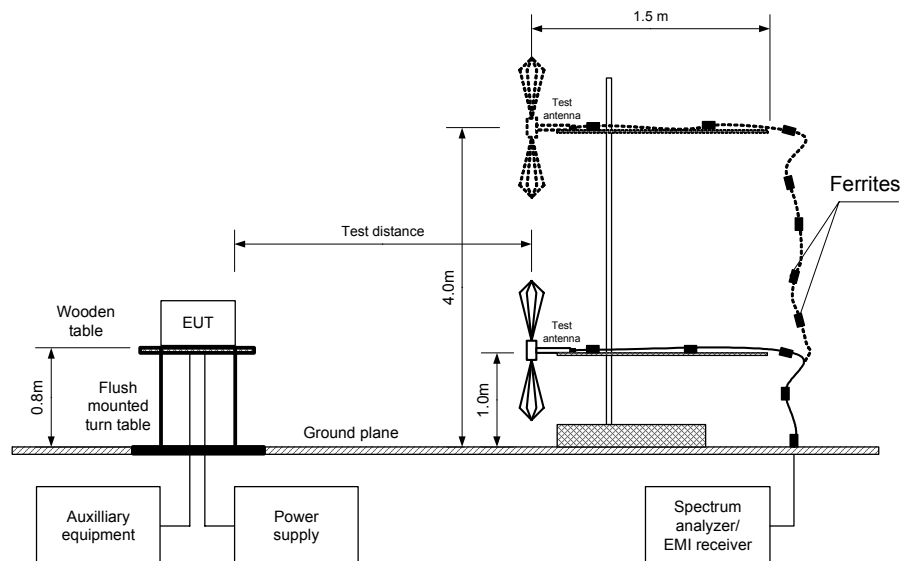

<b>Test specification:</b>		<b>Section 15.249(d), Band edge emissions</b>	
<b>Test procedure:</b>		ANSI C63.4, Section 13.1.4	
<b>Test mode:</b>	Compliance	<b>Verdict:</b>	PASS
<b>Date &amp; Time:</b>	4/5/2007 1:57:47 PM		
<b>Temperature:</b> 23°C	<b>Air Pressure:</b> 1007 hPa	<b>Relative Humidity:</b> 42 %	<b>Power Supply:</b> 12 V DC
<b>Remarks:</b>			

**Table 7.2.2 Band edge emission test results**

OPERATING FREQUENCY RANGE: 902-928 MHz  
 DETECTOR USED: Peak hold  
 RESOLUTION BANDWIDTH: 10 kHz  
 VIDEO BANDWIDTH: 30 kHz  
 MODULATION: FSK  
 MODULATING SIGNAL: ID code  
 TRANSMITTER OUTPUT POWER SETTINGS: Maximum

Modulation envelope		Band edge limit, MHz	Margin, kHz***	Verdict
Edge	Frequency, MHz*			
Low	902.030	902	30	Pass
High	902.165	928	25835	Pass

\* - Measured frequency beyond which the emission dropped 50 dB below the carrier emission or below the field strength limit whichever was a less stringent

\*\* - Margin = Band edge limit – Band edge frequency

**Note: band edge emission was performed according to delta marker method**

The delta between the highest emission and the spurious limit is:  
 at the carrier frequency: 91.8 dBµv/m – 46 dBµv/m = 45.8 dB

**Reference numbers of test equipment used**

HL 0521	HL 0589	HL 0604	HL 2009				
---------	---------	---------	---------	--	--	--	--

Full description is given in Appendix A.

<b>Test specification:</b>	<b>Section 15.249(d), Band edge emissions</b>		
<b>Test procedure:</b>	ANSI C63.4, Section 13.1.4		
<b>Test mode:</b>	Compliance	<b>Verdict:</b>	<b>PASS</b>
<b>Date &amp; Time:</b>	4/5/2007 1:57:47 PM		
<b>Temperature:</b> 23°C	<b>Air Pressure:</b> 1007 hPa	<b>Relative Humidity:</b> 42 %	<b>Power Supply:</b> 12 V DC
<b>Remarks:</b>			

Plot 7.2.1 Low band edge emission test result

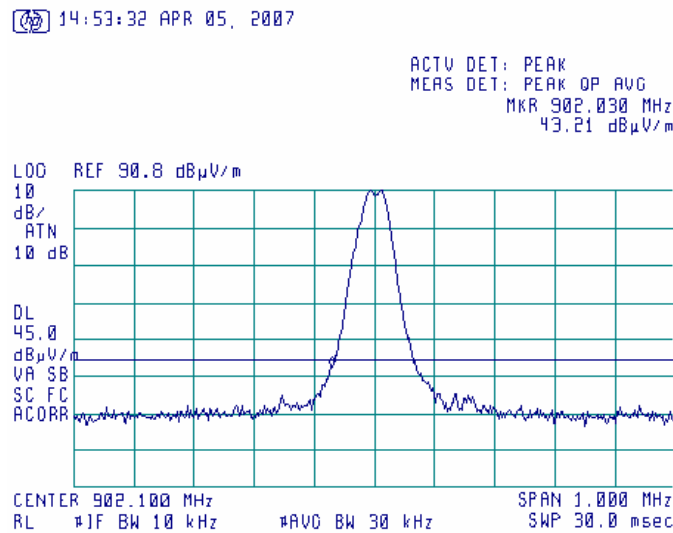

Limit line (dBμV/m)=90.8 dBμV/m - 45.8 dB = 45.0 dBμV/m

Plot 7.2.2 High band edge emission test result

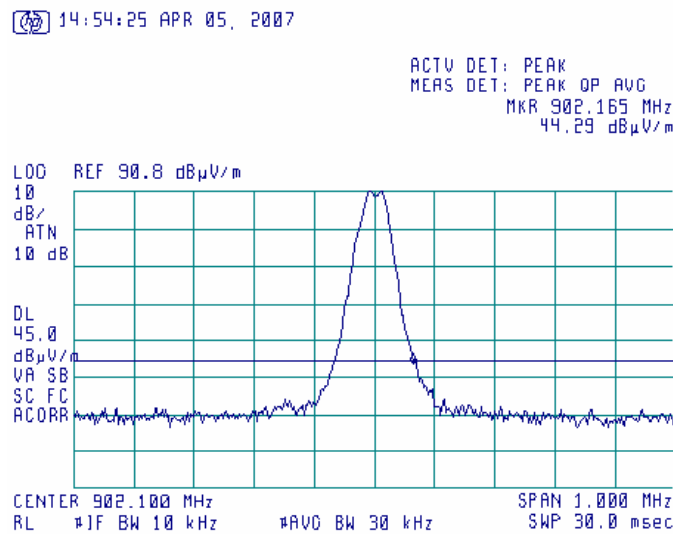

Limit line (dBμV/m) = 90.8 dBμV/m - 45.8 dB = 45.0 dBμV/m

<b>Test specification:</b>	<b>Section 15.203, Antenna requirement</b>		
<b>Test procedure:</b>	Visual inspection / supplier declaration		
<b>Test mode:</b>	Compliance	<b>Verdict:</b>	<b>PASS</b>
<b>Date &amp; Time:</b>	4/5/2007 10:46:15 AM		
<b>Temperature:</b> 23°C	<b>Air Pressure:</b> 1007 hPa	<b>Relative Humidity:</b> 42 %	<b>Power Supply:</b> 12 V DC
<b>Remarks:</b>			

### 7.3 Antenna requirements

The EUT was verified for compliance with antenna requirements. A transmitter shall be designed to ensure that no antenna other than that furnished by the responsible party will be used with the device. It may be either permanently attached or employs a unique antenna connector for every antenna proposed for use with the EUT. This requirement does not apply to professionally installed transmitters.

The rationale for compliance with the above requirements was either visual inspection results or supplier declaration. The summary of results is provided in Table 7.3.1.

**Table 7.3.1 Antenna requirements**

Requirement	Rationale	Verdict
The transmitter antenna is permanently attached	NA	Comply
The transmitter employs a unique antenna connector	NA	
The transmitter requires professional installation	Visual inspection, manufacturer's statement	

**Photograph 7.3.1 Antenna assembly**





<b>Test specification:</b> Section 15.109, Radiated emission			
<b>Test procedure:</b> ANSI C63.4, Sections 11.6 and 12.1.4			
<b>Test mode:</b> Compliance		<b>Verdict:</b> PASS	
<b>Date &amp; Time:</b> 4/4/2007 3:43:16 PM			
<b>Temperature:</b> 23°C	<b>Air Pressure:</b> 1009 hPa	<b>Relative Humidity:</b> 44 %	<b>Power Supply:</b> 12 V DC
<b>Remarks:</b>			

## 8 Emission tests according to 47CFR part 15 subpart B requirements

### 8.1 Radiated emission measurements

#### 8.1.1 General

This test was performed to measure radiated emissions from the EUT enclosure. Specification test limits are given in Table 8.1.1.

Table 8.1.1 Radiated emission test limits

Frequency, MHz	Class B limit, dB( $\mu$ V/m)		Class A limit, dB( $\mu$ V/m)	
	10 m distance	3 m distance	10 m distance	3 m distance
30 - 88	29.5*	40.0	39.0	49.5*
88 - 216	33.0*	43.5	43.5	54.0*
216 - 960	35.5*	46.0	46.4	56.9*
Above 960	43.5*	54.0	49.5	60.0*

\* The limit for test distance other than specified was calculated using the inverse linear distance extrapolation factor as follows:  $Lim_{S_2} = Lim_{S_1} + 20 \log(S_1/S_2)$ , where  $S_1$  and  $S_2$  – standard defined and test distance respectively in meters.

#### 8.1.2 Test procedure for measurements in semi-anechoic chamber

8.1.2.1 The EUT was set up as shown in Figure 8.1.1, energized and the performance check was conducted.

8.1.2.2 The specified frequency range was investigated with biconilog antenna connected to EMI receiver. To find maximum radiation the turntable was rotated 360°, the measuring antenna height was changed from 1 to 4 m, its polarization was switched from vertical to horizontal and the EUT cables position was varied.

8.1.2.3 The worst test results (the lowest margins) were recorded in Table 8.1.2 and shown in the associated plots.

Figure 8.1.1 Setup for radiated emission measurements in anechoic chamber, table-top equipment

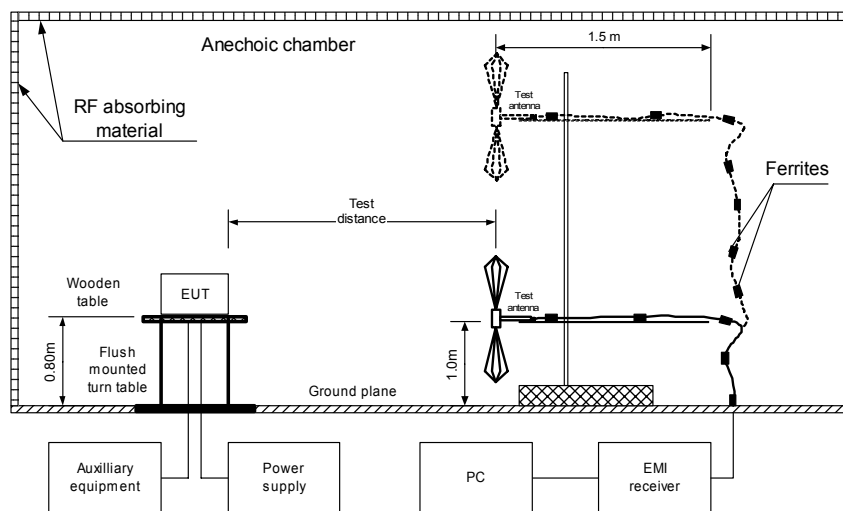

<b>Test specification:</b>	<b>Section 15.109, Radiated emission</b>		
<b>Test procedure:</b>	ANSI C63.4, Sections 11.6 and 12.1.4		
<b>Test mode:</b>	Compliance	<b>Verdict:</b>	<b>PASS</b>
<b>Date &amp; Time:</b>	4/4/2007 3:43:16 PM		
<b>Temperature:</b> 23°C	<b>Air Pressure:</b> 1009 hPa	<b>Relative Humidity:</b> 44 %	<b>Power Supply:</b> 12 V DC
<b>Remarks:</b>			

**Table 8.1.2 Radiated emission test results**

EUT SET UP: TABLE-TOP  
LIMIT: Class B  
EUT OPERATING MODE: Receive  
TEST SITE: ANECHOIC CHAMBER  
TEST DISTANCE: 3 m  
DETECTORS USED: PEAK / QUASI-PEAK  
FREQUENCY RANGE: 30 MHz – 1000 MHz  
RESOLUTION BANDWIDTH: 120 kHz

Frequency, MHz	Peak emission, dB(μV/m)	Quasi-peak			Antenna polarization	Antenna height, m	Turn-table position**, degrees	Verdict
		Measured emission, dB(μV/m)	Limit, dB(μV/m)	Margin, dB*				
All emissions were found more than 20 dB below the specified limit								Pass

TEST SITE: ANECHOIC CHAMBER  
TEST DISTANCE: 3 m  
DETECTORS USED: PEAK / AVERAGE  
FREQUENCY RANGE: 1000 – 10000 MHz  
RESOLUTION BANDWIDTH: 1000 kHz

Frequency, MHz	Peak emission, dB(μV/m)	Average			Antenna polarization	Antenna height, m	Turn-table position**, degrees	Verdict
		Measured emission, dB(μV/m)	Limit, dB(μV/m)	Margin, dB*				
All emissions were found more than 20 dB below the specified limit								Pass

\*- Margin = Measured emission - specification limit.

\*\*- EUT front panel refer to 0 degrees position of turntable.

**Reference numbers of test equipment used**

HL 1425	HL 1553	HL 1556	HL 1947	HL 1984	HL 2697	HL 2909	
---------	---------	---------	---------	---------	---------	---------	--

Full description is given in Appendix A.

<b>Test specification:</b> Section 15.109, Radiated emission			
<b>Test procedure:</b> ANSI C63.4, Sections 11.6 and 12.1.4			
<b>Test mode:</b> Compliance	<b>Verdict:</b> PASS		
<b>Date &amp; Time:</b> 4/4/2007 3:43:16 PM			
<b>Temperature:</b> 23°C	<b>Air Pressure:</b> 1009 hPa	<b>Relative Humidity:</b> 44 %	<b>Power Supply:</b> 12 V DC
<b>Remarks:</b>			

Plot 8.1.1 Radiated emission measurements in 30 - 1000 MHz range, vertical & horizontal antenna polarization

TEST SITE: Anechoic chamber  
LIMIT: Class B  
TEST DISTANCE: 3 m  
EUT OPERATING MODE: Receive

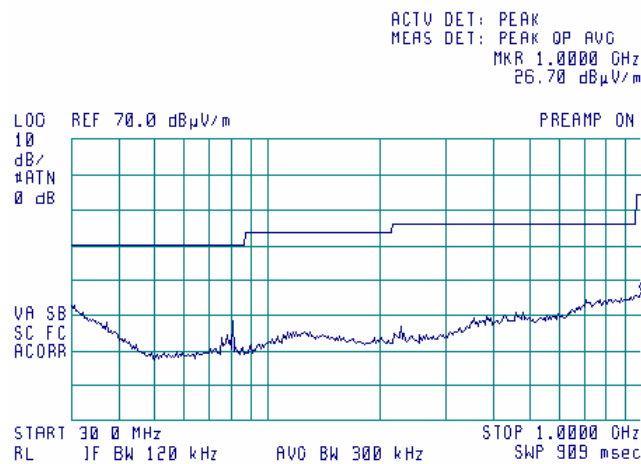

Plot 8.1.2 Radiated emission measurements in 1000 - 2900MHz, vertical & horizontal antenna polarization

TEST SITE: Anechoic chamber  
LIMIT: Class B  
TEST DISTANCE: 3 m  
EUT OPERATING MODE: Receive

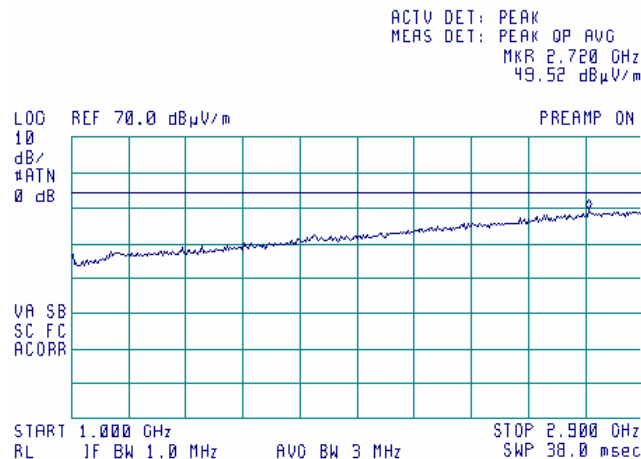

<b>Test specification:</b>	<b>Section 15.109, Radiated emission</b>		
<b>Test procedure:</b>	ANSI C63.4, Sections 11.6 and 12.1.4		
<b>Test mode:</b>	Compliance	<b>Verdict:</b>	<b>PASS</b>
<b>Date &amp; Time:</b>	4/4/2007 3:43:16 PM		
<b>Temperature:</b> 23°C	<b>Air Pressure:</b> 1009 hPa	<b>Relative Humidity:</b> 44 %	<b>Power Supply:</b> 12 V DC
<b>Remarks:</b>			

**Plot 8.1.3 Radiated emission measurements in 2900 – 10000 MHz, vertical & horizontal antenna polarization**

TEST SITE: Anechoic chamber  
LIMIT: Class B  
TEST DISTANCE: 3 m  
EUT OPERATING MODE: Receive

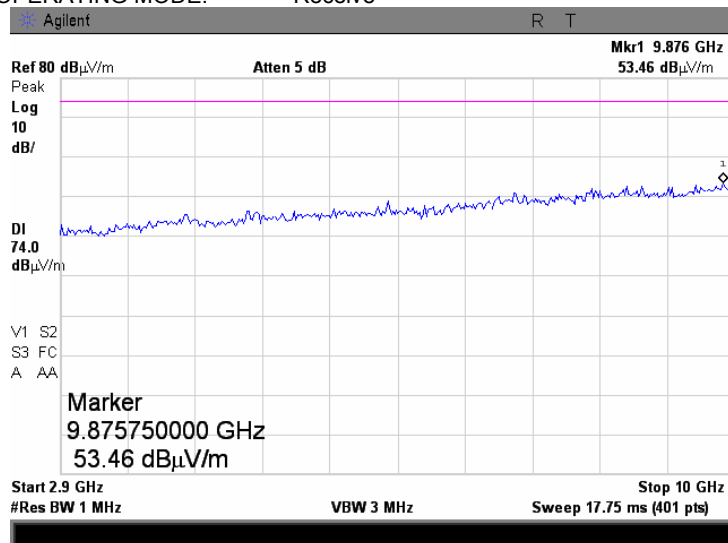

## 9 APPENDIX A Test equipment and ancillaries used for tests

HL No	Description	Manufacturer	Model	Ser. No.	Last Cal.	Due Cal.
0410	Cable, Coax, Microwave, DC-18 GHz, N-N, 1 m	Gore	PFP01P0 1039.4	9338767	17-Oct-06	17-Oct-07
0446	Antenna, Loop active, 10kHz-30MHz	EMCO	6502	2857	28-Jun-06	28-Jun-07
0465	Anechoic Chamber 9(L) x 6.5(W) x 5.5(H) m	HL	AC - 1	023	25-Aug-05	25-Aug-08
0521	EMI Receiver (Spectrum Analyzer) with RF filter section 9 kHz-6.5 GHz	Hewlett Packard	8546A	3617A 00319, 3448A002 53	26-Sep-06	26-Sep-07
0589	Cable Coaxial, GORE A2P01POL118, 2.3 m	HL	GORE-3	176	02-Dec-06	02-Dec-07
0592	Position Controller	HL	L2- SR3000 (HL CRL- 3)	100	18-May-06	18-May-07
0593	Antenna Mast, 1-4 m Pneumatic	Madgesh	AM-F1	101	02-Feb-07	02-Feb-08
0594	Turn Table FOR ANECHOIC CHAMBER flush mount d=1.2 m Pneumatic	HL	TT- WDC1	102	26-Jan-07	26-Jan-08
0604	Antenna BiconiLog Log-Periodic/T Bow- TIE, 26 - 2000 MHz	EMCO	3141	9611-1011	10-Jan-07	10-Jan-08
1200	Quadruplexer 1-12 GHz (1-2 GHz; 2- 4GHz;4-8 GHz; 8-12GHz)	Electronica S.p.A. - Roma	UE 84	D/00240	08-Feb-07	08-Feb-09
1425	EMI Receiver, 9 kHz - 2.9 GHz, System: HL1426, HL1427	Agilent Technologies	8542E	3710A002 22, 3705A002 04	01-Sep-06	01-Sep-07
1553	Cable RF, 3.5 m	Alpha Wire	RG-214	1553	02-Dec-06	02-Dec-07
1556	Cable RF, 0.5 m	Telequis	MIL-C- 17F-RG 058 CU	1556	12-Sep-06	12-Sep-07
1947	Cable 18GHz, 6.5 m, blue	Rhophase Microwave Limited	NPS- 1803A- 6500-NPS	T4974	17-Oct-06	17-Oct-07
1984	Antenna, Double-Ridged Waveguide Horn, 1-18 GHz, 300 W	EMC Test Systems	3115	9911-5964	03-Mar-07	03-Mar-08
2009	Cable RF, 8 m	Alpha Wire	RG-214	C-56	02-Dec-06	02-Dec-07
2259	Amplifier Low Noise 2-20 GHz	Sophia Wireless	LNA0220- C	0223	05-Nov-06	05-Nov-07
2387	Filter Bandpass, 8-14 GHz	HL	FBP8-14	2387	05-Jun-05	05-Jun-07
2697	Antenna, 30 MHz - 3.0 GHz,	Sunol Sciences. Corp. Pleasanton, California USA	JB3	A022805	10-Jan-07	10-Jan-08
2909	Spectrum analyzer, ESA-E, 100 Hz to 26.5 GHz	Agilent Technologies	E4407B	MY414447 62	07-May-07	07-May-08
2910	Cable 18 GHz, 3 m, SMA-SMA	Gore	NA	989370	30-Dec-06	30-Dec-07

## 10 APPENDIX B Measurement uncertainties

### Expanded uncertainty at 95% confidence in Hermon Labs EMC measurements

Test description	Expanded uncertainty
Radiated emissions at 10 m measuring distance Horizontal polarization  Vertical polarization	Biconilog antenna: $\pm 5.0$ dB Biconical antenna: $\pm 5.0$ dB Log periodic antenna: $\pm 5.1$ dB Double ridged horn antenna: $\pm 5.3$ dB Biconilog antenna: $\pm 5.5$ dB Biconical antenna: $\pm 5.5$ dB Log periodic antenna: $\pm 5.6$ dB Double ridged horn antenna: $\pm 5.8$ dB
Radiated emissions at 3 m measuring distance Horizontal polarization  Vertical polarization	Biconilog antenna: $\pm 5.3$ dB Biconical antenna: $\pm 5.0$ dB Log periodic antenna: $\pm 5.3$ dB Double ridged horn antenna: $\pm 5.3$ dB Biconilog antenna: $\pm 6.0$ dB Biconical antenna: $\pm 5.7$ dB Log periodic antenna: $\pm 6.0$ dB Double ridged horn antenna: $\pm 6.0$ dB
Conducted emissions at RF antenna connector	9 kHz to 2.9 GHz: $\pm 2.6$ dB 2.9 GHz to 6.46 GHz: $\pm 3.5$ dB 6.46 GHz to 13.2 GHz: $\pm 4.3$ dB 13.2 GHz to 22.0 GHz: $\pm 5.0$ dB 22.0 GHz to 26.8 GHz: $\pm 5.5$ dB 26.8 GHz to 40.0 GHz: $\pm 4.8$ dB

Hermon Laboratories is accredited by A2LA for calibration according to present requirements of ISO/IEC 17025 and NCSL Z540-1. The accreditation is granted to perform calibration of parameters that are listed in the Scope of Hermon Laboratories Accreditation.

Hermon Laboratories calibrates its reference and transfer standards by calibration laboratories accredited to ISO/IEC 17025 by a mutually recognized Accreditation Body or by a recognized national metrology institute. All reference and transfer standards used in the calibration system are traceable to national or international standards.

In-house calibration of all test and measurement equipment is performed on a regular basis according to Hermon Laboratories calibration procedures, manufacturer calibration/verification procedures or procedures defined in the relevant standards. The Hermon Laboratories test and measurement equipment is calibrated within the tolerances specified by the manufacturers and/or by the relevant standards.

## 11 APPENDIX C Test laboratory description

Tests were performed at Hermon Laboratories Ltd., which is a fully independent, private, EMC, safety, environmental and telecommunication testing facility. Hermon Laboratories is listed by the Federal Communications Commission (USA) for all parts of Code of Federal Regulations 47 (CFR 47) and by Industry Canada for electromagnetic emissions (file numbers IC 2186-1 for OATS and IC 2186-2 for anechoic chamber), certified by VCCI, Japan (the registration numbers are R-808 for OATS, R-1082 for anechoic chamber, C-845 for conducted emissions site), assessed by TNO Certification EP&S (Netherlands) for a number of EMC, telecommunications, environmental, safety standards, and by AMTAC (UK) for safety of medical devices. The laboratory is accredited by American Association for Laboratory Accreditation (USA) according to ISO/IEC 17025 for electromagnetic compatibility, product safety, telecommunications testing and environmental simulation (for exact scope please refer to Certificate No. 839.01).

Address: P.O. Box 23, Binyamina 30500, Israel.  
Telephone: +972 4628 8001  
Fax: +972 4628 8277  
e-mail: mail@hermonlabs.com  
website: www.hermonlabs.com

Person for contact: Mr. Alex Usoskin, CEO.

## 12 APPENDIX D Specification references

47CFR part 15: 2006	Radio Frequency Devices.
ANSI C63.2: 1996	American National Standard for Instrumentation-Electromagnetic Noise and Field Strength, 10 kHz to 40 GHz-Specifications.
ANSI C63.4: 2003	American National Standard for Methods of Measurement of Radio-Noise Emissions from Low-Voltage Electrical and Electronic Equipment in the Range of 9 kHz to 40 GHz.

### 13 APPENDIX E Abbreviations and acronyms

A	ampere
AC	alternating current
AM	amplitude modulation
AVRG	average (detector)
cm	centimeter
dB	decibel
dBm	decibel referred to one milliwatt
dB( $\mu$ V)	decibel referred to one microvolt
dB( $\mu$ V/m)	decibel referred to one microvolt per meter
dB( $\mu$ A)	decibel referred to one microampere
dB $\Omega$	decibel referred to one Ohm
DC	direct current
EUT	equipment under test
F	frequency
GHz	gigahertz
GND	ground
H	height
HL	Hermon laboratories
Hz	hertz
ITE	information technology equipment
k	kilo
kHz	kilohertz
LO	local oscillator
m	meter
MHz	megahertz
min	minute
mm	millimeter
ms	millisecond
$\mu$ s	microsecond
NA	not applicable
NT	not tested
OATS	open area test site
$\Omega$	Ohm
QP	quasi-peak
RE	radiated emission
RF	radio frequency
rms	root mean square
Rx	receive
s	second
T	temperature
Tx	transmit
V	volt
WB	wideband



## 14 APPENDIX F Test equipment correction factors

**Antenna factor**  
**Active loop antenna**  
**Model 6502, S/N 2857, HL 0446**

Frequency, MHz	Magnetic antenna factor, dB	Electric antenna factor, dB
0.009	-32.8	18.7
0.010	-33.8	17.7
0.020	-38.3	13.2
0.050	-41.1	10.4
0.075	-41.3	10.2
0.100	-41.6	9.9
0.150	-41.7	9.8
0.250	-41.6	9.9
0.500	-41.8	9.8
0.750	-41.9	9.7
1.000	-41.4	10.1
2.000	-41.5	10.0
3.000	-41.4	10.2
4.000	-41.4	10.1
5.000	-41.5	10.1
10.000	-41.9	9.6
15.000	-41.9	9.6
20.000	-42.2	9.3
25.000	-42.8	8.7
30.000	-44.0	7.5

Antenna factor in dB(1/m) is to be added to receiver meter reading in dB( $\mu$ V) to convert it into field intensity in dB( $\mu$ V/m).

**Antenna factor**  
**Log periodic antenna**  
**Electro-Metrics, model LPA-25/30**  
**Ser.No.1988, HL 0034**

Frequency MHz	Antenna Factor dB(1/m)	Frequency MHz	Antenna Factor dB(1/m)
200	12.6	625	20.4
225	12.2	650	20.9
250	13.4	675	22.0
275	14.3	700	22.2
300	15.2	725	22.7
325	15.7	750	22.5
350	15.9	775	22.7
375	16.4	800	22.8
400	17.0	825	23.2
425	17.4	850	23.5
450	17.9	875	23.9
475	18.6	900	24.0
500	19.1	925	24.0
525	19.3	950	24.2
550	19.6	975	24.7
575	19.8	1000	25.1
600	20.0		

Antenna factor in dB(1/m) is to be added to receiver meter reading in dB( $\mu$ V) to convert it into field intensity in dB( $\mu$ V/m).

**Antenna factor  
Biconilog antenna EMCO Model 3141  
Ser.No.1011, HL 0604**

Frequency, MHz	Antenna Factor, dB(1/m)	Frequency, MHz	Antenna Factor, dB(1/m)
26	7.8	940	24.0
28	7.8	960	24.1
30	7.8	980	24.5
40	7.2	1000	24.9
60	7.1	1020	25.0
70	8.5	1040	25.2
80	9.4	1060	25.4
90	9.8	1080	25.6
100	9.7	1100	25.7
110	9.3	1120	26.0
120	8.8	1140	26.4
130	8.7	1160	27.0
140	9.2	1180	27.0
150	9.8	1200	26.7
160	10.2	1220	26.5
170	10.4	1240	26.5
180	10.4	1260	26.5
190	10.3	1280	26.6
200	10.6	1300	27.0
220	11.6	1320	27.8
240	12.4	1340	28.3
260	12.8	1360	28.2
280	13.7	1380	27.9
300	14.7	1400	27.9
320	15.2	1420	27.9
340	15.4	1440	27.8
360	16.1	1460	27.8
380	16.4	1480	28.0
400	16.6	1500	28.5
420	16.7	1520	28.9
440	17.0	1540	29.6
460	17.7	1560	29.8
480	18.1	1580	29.6
500	18.5	1600	29.5
520	19.1	1620	29.3
540	19.5	1640	29.2
560	19.8	1660	29.4
580	20.6	1680	29.6
600	21.3	1700	29.8
620	21.5	1720	30.3
640	21.2	1740	30.8
660	21.4	1760	31.1
680	21.9	1780	31.0
700	22.2	1800	30.9
720	22.2	1820	30.7
740	22.1	1840	30.6
760	22.3	1860	30.6
780	22.6	1880	30.6
800	22.7	1900	30.6
820	22.9	1920	30.7
840	23.1	1940	30.9
860	23.4	1960	31.2
880	23.8	1980	31.6
900	24.1	2000	32.0
920	24.1		

Antenna factor in dB(1/m) is to be added to receiver meter reading in dB( $\mu$ V) to convert it into field intensity in dB( $\mu$ V/m).

**Antenna factor  
Double-ridged wave guide horn antenna  
Model 3115, S/N 9911-5964, HL1984**

Frequency, MHz	Antenna factor, dB(1/m)
1000.0	24.7
1500.0	25.7
2000.0	27.6
2500.0	28.9
3000.0	31.2
3500.0	32.0
4000.0	32.5
4500.0	32.7
5000.0	33.6
5500.0	35.1
6000.0	35.4
6500.0	34.9
7000.0	36.1
7500.0	37.8
8000.0	38.0
8500.0	38.1
9000.0	39.1
9500.0	38.3
10000.0	38.6
10500.0	38.2
11000.0	38.7
11500.0	39.5
12000.0	40.0
12500.0	40.4
13000.0	40.5
13500.0	41.1
14000.0	41.6
14500.0	41.7
15000.0	38.7
15500.0	38.2
16000.0	38.8
16500.0	40.5
17000.0	42.5
17500.0	45.9
18000.0	49.4

Antenna factor in dB(1/m) is to be added to receiver meter reading in dB( $\mu$ V) to convert it into field intensity in dB( $\mu$ V/m).

Antenna calibration  
Sunol Sciences Inc., model JB3, serial number A022805

Frequency, MHz	ACF, dB	Gain, dBi	Num gain	Frequency, MHz	ACF, dB	Gain, dBi	Num gain	Frequency, MHz	ACF, dB	Gain, dBi	Num gain	Frequency, MHz	ACF, dB	Gain, dBi	Num gain	Frequency, MHz	ACF, dB	Gain, dBi	Num gain
30	22.2	-22.5	0.01	620	19.7	6.3	4.27	1215	24.9	7.0	5.05	1810	28.3	7.1	5.08	2405	30.9	6.9	4.93
35	18.5	-17.4	0.02	625	19.7	6.5	4.42	1220	24.9	7.0	4.99	1815	28.5	6.9	4.91	2410	30.9	6.9	4.89
40	14.7	-12.5	0.06	630	19.6	6.6	4.57	1225	25.1	6.9	4.91	1820	28.6	6.8	4.74	2415	31.0	6.9	4.85
45	11.3	-8.1	0.16	635	19.7	6.5	4.48	1230	25.2	6.8	4.82	1825	28.7	6.8	4.76	2420	31.0	6.8	4.82
45	11.3	-8.1	0.16	640	19.9	6.4	4.40	1235	25.1	7.0	4.96	1830	28.7	6.8	4.76	2425	31.1	6.8	4.81
50	8.9	-4.7	0.34	645	19.9	6.5	4.45	1240	25.0	7.1	5.09	1835	28.7	6.7	4.72	2430	31.0	6.9	4.87
55	7.9	-2.8	0.52	650	19.9	6.5	4.51	1245	25.0	7.1	5.12	1840	28.8	6.7	4.69	2435	31.0	6.9	4.88
60	7.8	-2.1	0.62	655	19.9	6.6	4.60	1250	25.0	7.1	5.15	1845	28.6	6.9	4.90	2440	31.2	6.8	4.74
65	2.0	0.63	0.83	660	19.9	6.7	4.69	1255	25.0	7.2	5.25	1850	28.4	7.1	5.12	2445	31.1	6.9	4.91
70	9.0	-1.9	0.64	665	19.9	6.7	4.70	1260	24.9	7.3	5.36	1855	28.5	7.0	5.07	2450	31.0	7.0	4.96
75	8.8	-1.1	0.78	670	20.0	6.7	4.71	1265	25.0	7.3	5.31	1860	28.6	7.0	5.01	2455	31.0	7.0	5.01
80	8.4	-0.2	0.97	675	20.1	6.7	4.71	1270	25.1	7.2	5.26	1865	28.5	7.1	5.17	2460	30.9	7.2	5.19
85	8.0	0.8	1.20	680	20.1	6.7	4.71	1275	25.3	7.0	5.05	1870	28.4	7.3	5.33	2465	31.1	6.9	4.95
90	9.2	1.1	1.29	685	20.1	6.8	4.79	1280	25.5	6.8	4.94	1875	28.4	7.2	5.28	2470	31.3	6.8	4.76
95	9.2	0.5	1.13	690	20.1	6.9	4.88	1285	25.4	7.0	4.97	1880	28.5	7.2	5.22	2475	31.4	6.7	4.69
100	10.6	-0.4	0.92	695	20.2	6.8	4.82	1290	25.3	7.1	5.10	1885	28.5	7.2	5.22	2480	31.3	6.8	4.79
105	11.7	-1.1	0.78	700	20.3	6.8	4.76	1295	25.3	7.2	5.22	1890	28.6	7.2	5.21	2485	31.1	7.0	5.00
110	12.6	-1.6	0.70	705	20.4	6.8	4.75	1300	25.2	7.3	5.31	1895	28.6	7.2	5.24	2490	31.1	7.0	4.99
115	13.3	-1.9	0.65	710	20.5	6.8	4.75	1305	25.2	7.3	5.21	1900	28.6	7.2	5.27	2495	31.2	7.0	4.99
120	13.9	-2.1	0.62	715	20.5	6.8	4.80	1310	25.5	7.1	5.09	1905	28.5	7.3	5.36	2500	30.9	7.2	5.27
125	14.2	-2.0	0.63	720	20.5	6.9	4.85	1315	25.4	7.2	5.23	1910	28.5	7.4	5.45	2505	31.1	7.1	5.15
130	14.2	-1.7	0.68	725	20.6	6.8	4.81	1320	25.3	7.3	5.36	1915	28.5	7.3	5.38	2510	31.0	7.2	5.22
135	13.8	-1.0	0.79	730	20.7	6.8	4.77	1325	25.5	7.2	5.21	1920	28.6	7.3	5.31	2515	31.0	7.2	5.26
140	13.4	0.3	0.94	735	20.9	6.7	4.65	1330	25.6	7.0	5.06	1925	28.6	7.3	5.38	2520	31.2	7.0	5.05
145	13.1	0.3	1.08	740	21.0	6.6	4.53	1335	25.7	7.1	5.07	1930	28.6	7.3	5.39	2525	30.8	7.4	5.54
150	12.9	0.8	1.21	745	21.0	6.6	4.59	1340	25.7	7.1	5.09	1935	28.5	7.4	5.54	2530	31.0	7.3	5.37
160	12.7	1.6	1.44	755	21.0	6.8	4.74	1350	25.7	7.1	5.17	1945	28.5	7.5	5.69	2540	31.2	7.1	5.09
165	12.5	2.0	1.59	760	21.0	6.8	4.83	1355	25.8	7.0	5.06	1950	28.6	7.4	5.48	2545	31.0	7.3	5.43
170	12.6	2.6	1.83	765	21.1	6.8	4.73	1360	25.8	7.1	5.17	1955	28.6	7.4	5.45	2550	31.0	7.3	5.39
175	11.8	3.3	2.13	770	21.3	6.7	4.64	1365	26.0	6.9	4.95	1960	28.6	7.5	5.65	2555	31.1	7.2	5.30
180	11.6	3.7	2.36	775	21.3	6.7	4.68	1370	26.0	7.0	4.96	1965	28.7	7.4	5.47	2560	31.0	7.4	5.47
190	11.6	4.2	2.61	785	21.3	6.8	4.77	1380	26.0	7.0	5.06	1975	28.9	7.2	5.22	2570	31.1	7.3	5.37
200	13.1	3.2	2.07	795	21.4	6.8	4.79	1390	26.1	6.9	4.92	1985	29.1	7.1	5.11	2580	31.6	6.9	4.87
205	14.4	4.4	2.78	800	21.5	6.8	4.77	1395	26.2	6.9	4.94	1990	29.1	7.0	5.06	2585	31.6	6.9	4.79
210	11.0	5.6	3.66	805	21.6	6.7	4.71	1400	26.2	7.0	4.96	1995	29.1	7.1	5.09	2590	31.6	6.9	4.88
215	11.3	5.6	3.99	810	21.7	6.7	4.65	1405	26.1	7.0	5.02	2000	29.1	7.1	5.11	2595	31.5	7.0	4.97
220	11.6	5.5	3.62	815	21.7	6.7	4.72	1410	26.1	7.1	5.09	2005	29.1	7.1	5.16	2600	31.6	6.9	4.86
225	11.7	5.5	3.55	820	21.7	6.8	4.80	1415	26.2	7.0	5.02	2010	29.1	7.1	5.15	2605	31.3	7.2	5.30
230	11.9	5.5	3.57	825	21.7	6.8	4.82	1420	26.3	7.0	4.96	2015	29.2	7.1	5.13	2610	31.4	7.1	5.15
235	12.1	5.5	3.56	830	21.7	6.8	4.85	1425	26.2	7.1	5.10	2020	29.2	7.1	5.18	2615	31.7	6.9	4.88
240	12.3	5.5	3.54	835	21.8	6.8	4.82	1430	26.1	7.2	5.25	2025	29.3	7.1	5.08	2620	31.6	7.0	4.97
245	12.3	5.7	3.71	840	21.9	6.8	4.80	1435	26.1	7.2	5.24	2030	29.3	7.0	5.05	2625	31.4	7.1	5.17
250	12.3	5.9	3.88	845	21.9	6.8	4.83	1440	26.2	7.2	5.24	2035	29.3	7.1	5.07	2630	31.6	7.0	5.00
255	12.5	5.9	3.85	850	21.9	6.9	4.86	1445	26.3	7.1	5.11	2040	29.3	7.1	5.13	2635	31.8	6.8	4.82
260	12.7	5.8	3.83	855	22.0	6.8	4.80	1450	26.5	7.0	4.98	2045	29.2	7.2	5.23	2640	31.7	7.0	4.98
265	13.2	5.5	3.54	860	22.1	6.8	4.74	1455	26.4	7.1	5.07	2050	29.2	7.2	5.27	2645	31.7	6.9	4.93
270	13.7	5.2	3.27	865	22.0	6.9	4.92	1460	26.4	7.1	5.17	2055	29.3	7.2	5.21	2650	31.8	6.9	4.85
275	13.7	5.3	3.39	870	21.9	7.1	5.11	1465	26.4	7.2	5.19	2060	29.5	7.0	5.02	2655	31.8	6.9	4.85
280	13.7	5.4	3.50	875	22.0	7.1	5.08	1470	26.4	7.2	5.22	2065	29.4	7.1	5.08	2660	31.7	7.0	5.02
285	13.7	5.6	3.61	880	22.1	7.0	5.05	1475	26.4	7.1	5.17	2070	29.4	7.1	5.10	2665	32.0	6.7	4.71
290	13.7	5.7	3.72	885	22.1	7.0	5.06	1480	26.5	7.1	5.12	2075	29.5	7.0	5.01	2670	32.0	6.7	4.67
295	13.8	5.8	3.77	890	22.1	7.0	5.08	1485	26.5	7.1	5.14	2080	29.8	6.8	4.78	2675	31.9	6.8	4.81
300	13.9	5.8	3.81	895	22.2	7.1	5.09	1490	26.5	7.1	5.17	2085	29.7	6.8	4.88	2680	31.9	7.0	5.04
305	14.0	5.9	3.85	900	22.2	7.1	5.12	1495	26.5	7.2	5.24	2090	29.7	6.9	4.86	2685	31.9	6.8	4.83
310	14.1	5.9	3.88	905	22.3	7.1	5.09	1500	26.5	7.2	5.31	2095	29.8	6.8	4.78	2690	32.1	6.7	4.72
315	14.3	5.9	3.89	910	22.3	7.0	5.05	1505	26.5	7.2	5.27	2100	29.9	6.8	4.75	2695	32.1	6.7	4.71
320	14.4	5.9	3.90	915	22.4	7.0	4.99	1510	26.6	7.2	5.23	2105	29.8	6.8	4.81	2700	32.0	6.8	4.81
325	14.5	5.9	3.92	920	22.6	6.9	4.92	1515	26.6	7.2	5.30	2110	29.9	6.8	4.78	2705	32.0	6.8	4.80
330	14.6	5.9	3.93	925	22.7	6.9	4.85	1520	26.5	7.3	5.38	2115	29.9	6.8	4.76	2710	32.1	6.8	4.79
335	14.7	6.0	4.02	930	22.8	6.8	4.77	1525	26.6	7.3	5.37	2120	29.9	6.8	4.84	2715	32.1	6.8	4.71
340	14.7	6.2	4.12	935	22.8	6.8	4.83	1530	26.6	7.3	5.36	2125	29.9	6.9	4.89	2720	32.4	6.5	4.47
345	14.9	6.1	4.06	940	22.8	6.9	4.89	1535	26.6	7.4	5.44	2130	29.9	6.9	4.80	2725	32.2	6.7	4.63
350	15.1	6.0	3.99	945	22.8	6.9	4.87	1540	26.5	7.4	5.53	2135	29.8	6.9	4.94	2730	31.9	7.0	5.05
360	15.6	5.8	3.78	955	23.0	6.8	4.81	1550	26.5	7.5	5.63	2145	29.9	6.9	4.92	2740	31.6	7.1	5.46
365	15.5	5.9	3.89	960	23.1	6.8	4.77	1555	26.7	7.3	5.39	2150	29.9	7.0	4.98	2745	31.9	7.0	5.06
370	15.5	6.0	4.01	965	23.1	6.7	4.73	1560	26.9	7.1	5.16	2155	29.8	7.1	5.10	2750	32.0	6.9	4.94
375	15.6	6.1	4.03	970	23.2	6.7	4.69	1565	26.9	7.2	5.23	2160	29.8	7.1	5.09	2755	32.0	7.0	4.98
380	15.7	6.1	4.05	975	23														

**Cable loss**  
**Cable GORE, HL 0410**

No.	Frequency, GHz	Cable loss, dB
1	0.5	0.16
2	1	0.28
3	2	0.38
4	4	0.55
5	6	0.85
6	8	0.90
7	10	1.07
8	12	1.11
9	14	1.29
10	16	1.41
11	18	1.73

**Cable loss**  
**RF cable 3.5 m, Alpha Wire, model RG-214, S/N 149, HL 1553**

No.	Frequency, MHz	Cable loss, dB	Measurement uncertainty, dB
1	1	0.01	±0.05
2	10	0.07	
3	30	0.12	
4	50	0.22	
5	100	0.26	
6	200	0.40	
7	300	0.52	
8	400	0.60	
9	500	0.70	
10	600	0.77	
11	700	0.84	
12	800	1.00	
13	900	1.00	
14	1000	1.05	
15	2000	1.70	

**Cable loss**  
**Cable Coaxial, GORE A2P01POL118, 2.3 m, model:GORE-3, HL 0589**  
**+ Cable Coaxial, ANDREW PSWJ4, 6m, model: ANDREW-6, HL 1004**

No.	Frequency, MHz	Cable loss, dB	Tolerance (Specification), dB	Measurement uncertainty, dB
1	30	0.33	≤ 6.5	±0.12
2	50	0.40		
3	100	0.57		
4	300	0.97		
5	500	1.25		
6	800	1.59		
7	1000	1.81		
8	1200	1.97		
9	1400	2.15		
10	1600	2.28		
11	1800	2.43		
12	2000	2.61		
13	2200	2.75		
14	2400	2.89		
15	2600	2.97		
16	2800	3.21	≤ 6.5	±0.12
17	3000	3.32		
18	3300	3.47		
19	3600	3.62		
20	3900	3.84		
21	4200	3.92		
22	4500	4.07		
23	4800	4.36		
24	5100	4.62		
25	5400	4.78		
26	5700	5.16		
27	6000	5.67		
28	6500	5.99		

**Cable loss**  
**Cable 18 GHz, 6.5 m, blue, model: NPS-1803A-6500-NPS, S/N T4974, HL 1947**

Frequency, GHz	Cable loss, dB
0.03	0.30
0.05	0.38
0.10	0.53
0.20	0.74
0.30	0.91
0.40	1.05
0.50	1.18
0.60	1.29
0.70	1.40
0.80	1.50
0.90	1.59
1.00	1.68
1.10	1.77
1.20	1.86
1.30	1.94
1.40	2.01
1.50	2.08
1.60	2.16
1.70	2.22
1.80	2.29
1.90	2.36
2.00	2.42
2.10	2.48
2.20	2.54
2.30	2.60
2.40	2.66
2.50	2.71
2.60	2.77
2.70	2.83
2.80	2.89
2.90	2.95
3.10	3.06
3.30	3.17
3.50	3.28
3.70	3.39
3.90	3.51
4.10	3.62
4.30	3.76
4.50	3.87
4.70	4.01
4.90	4.10
5.10	4.21
5.30	4.31
5.50	4.43
5.70	4.56
5.90	4.71

Frequency, GHz	Cable loss, dB
6.10	4.87
6.30	4.95
6.50	4.94
6.70	4.88
6.90	4.87
7.10	4.83
7.30	4.85
7.50	4.86
7.70	4.91
7.90	4.96
8.10	5.03
8.30	5.08
8.50	5.13
8.70	5.21
8.90	5.22
9.10	5.34
9.30	5.35
9.50	5.52
9.70	5.51
9.90	5.66
10.10	5.70
10.30	5.78
10.50	5.79
10.70	5.82
10.90	5.86
11.10	5.94
11.30	6.06
11.50	6.21
11.70	6.44
11.90	6.61
12.10	6.76
12.40	6.68
13.00	6.66
13.50	6.81
14.00	6.90
14.50	6.90
15.00	6.97
15.50	7.17
16.00	7.28
16.50	7.27
17.00	7.38
17.50	7.68
18.00	7.92

**Cable loss**  
**RF cable 8 m, model RG-214, HL 2009**

No.	Frequency, MHz	Cable loss, dB	Tolerance (Specification), dB	Measurement uncertainty, dB
1	1	0.10	NA	±0.12
2	10	0.14		
3	30	0.25		
4	50	0.34		
5	100	0.53		
6	300	0.99		
7	500	1.31		
8	800	1.73		
9	1000	1.98		
10	1100	2.11		
11	1200	2.21		
12	1300	2.35		
13	1400	2.46		
14	1500	2.55		
15	1600	2.68		
16	1700	2.78		
17	1800	2.88		
18	1900	2.98		
19	2000	3.09		



**Cable loss**  
**Cable coaxial, Gore, 18 GHz, 3m, SMA-SMA, S/N 989370**  
**HL 2910**

Frequency, GHz	Cable loss, dB	Frequency, GHz	Cable loss, dB	Frequency, GHz	Cable loss, dB
10	0.07	5750	2.97	12000	5.05
30	0.19	6000	2.91	12250	4.44
100	0.36	6250	3.23	12500	4.82
250	0.53	6500	3.42	12750	5.22
500	0.77	6750	3.17	13000	5.02
750	0.94	7000	3.56	13250	5.00
1000	1.10	7250	3.77	13500	5.09
1250	1.19	7500	3.48	13750	4.70
1500	1.35	7750	3.81	14000	5.03
1750	1.51	8000	3.82	14250	5.17
2000	1.57	8250	3.62	14500	4.92
2250	1.69	8500	3.95	14750	4.91
2500	1.76	8750	4.00	15000	5.03
2750	1.83	9000	3.80	15250	4.93
3000	2.02	9250	4.09	15500	5.28
3250	2.17	9500	4.12	15750	5.60
3500	2.13	9750	4.11	16000	5.16
3750	2.23	10000	4.36	16250	5.45
4000	2.40	10250	4.75	16500	5.78
4250	2.31	10500	4.61	16750	5.47
4500	2.52	10750	4.26	17000	5.21
4750	2.77	11000	4.62	17250	5.53
5000	2.82	11250	4.55	17500	5.53
5250	2.77	11500	4.59	17750	5.71
5500	3.04	11750	5.20	18000	5.77