

Project No: TM-2402000257P
Report No.: TMWK2406002111KR

FCC ID: JNF-BTS-319XP

Page: 1 / 61
Rev.: 03

RADIO TEST REPORT

FCC 47 CFR PART 15 SUBPART C

Test Standard	FCC Part 15.247
Product name	Wireless Handheld Barcode Scanner
Brand Name	ZEBEX
Model No.	Z-3190BT Plus, Z-3192BT Plus
Test Result	Pass
Statements of Conformity	Determination of compliance is based on the results of the compliance measurement, not taking into account measurement instrumentation uncertainty.

The test Result was tested by Compliance Certification Services Inc. The test data, data evaluation, test procedures, and equipment configurations shown in this report were given in ANSI C63.10: 2013 and compliance standards.

The test results of this report relate only to the tested sample (EUT) identified in this report.

The test Report of full or partial shall not copy. Without written approval of Compliance Certification Services Inc.(Wugu Laboratory)

Approved by:



Shawn Wu
Supervisor

Unless otherwise stated the results shown in this test report refer only to the sample(s) tested and such sample(s) are retained for 90 days only.
除非另有說明，此報告結果僅對測試之樣品負責，同時此樣品僅保留90天。本報告未經本公司書面許可，不可部份複製。

This document is issued by the Company subject to its General Conditions of Service printed overleaf, available on request or accessible at <http://www.sgs.com.tw/Terms-and-Conditions> and, for electronic format documents, subject to Terms and Conditions for Electronic Documents at <http://www.sgs.com.tw/Terms-and-Conditions>. Attention is drawn to the limitation of liability, indemnification and jurisdiction issues defined therein. Any holder of this document is advised that information contained hereon reflects the Company's findings at the time of its intervention only and within the limits of client's instruction, if any. The Company's sole responsibility is to its Client and this document does not exonerate parties to a transaction from exercising all their rights and obligations under the transaction documents. This document cannot be reproduced, except in full, without prior written approval of the Company. Any unauthorized alteration, forgery or falsification of the content or appearance of this document is unlawful and offenders may be prosecuted to the fullest extent of the law.

Revision History

Rev.	Issue Date	Revisions	Effect Page	Revised By
00	July 3, 2024	Initial Issue	ALL	Peggy Tsai
01	July 9, 2024	See the following Note Rev. (01)	P.1, 4, 7, 14, 21, 22, 27, 30, 32, 48,49	Peggy Tsai
02	July 15, 2024	See the following Note Rev. (02)	P. A-3	Peggy Tsai
03	July 18, 2024	See the following Note Rev. (03)	P. 4	Peggy Tsai

Note:

Rev. (01)

1. Modify model to Z-3190BT Plus, Z-3192BT Plus.
2. Modify HW Version in section 1.1.
3. Modify date of test in section 1.1.
4. Modify instrument calibration in section 1.6.
5. Modify date of RF Conducted test.
6. Modify test procedure in section 4.2.2.
7. Modify TX test data in section 4.6.4.

Rev. (02)

1. Modify conducted emission set up photo.

Rev. (03)

1. Modify SW version.

Table of contents

1.	GENERAL INFORMATION	4
1.1	EUT INFORMATION	4
1.2	EUT CHANNEL INFORMATION	5
1.3	ANTENNA INFORMATION	5
1.4	MEASUREMENT UNCERTAINTY.....	6
1.5	FACILITIES AND TEST LOCATION	6
1.6	INSTRUMENT CALIBRATION	7
1.7	SUPPORT AND EUT ACCESSORIES EQUIPMENT	9
1.8	TEST SET UP DIAGRAM.....	10
1.9	TEST METHODOLOGY AND APPLIED STANDARDS	10
2.	TEST SUMMERY	11
3.	DESCRIPTION OF TEST MODES.....	12
3.1	THE WORST MODE OF OPERATING CONDITION	12
3.2	THE WORST MODE OF MEASUREMENT	13
3.3	EUT DUTY CYCLE.....	14
4.	TEST RESULT	16
4.1	AC POWER LINE CONDUCTED EMISSION	16
4.2	6DB BANDWIDTH AND OCCUPIED BANDWIDTH(99%)	21
4.3	OUTPUT POWER MEASUREMENT	26
4.4	POWER SPECTRAL DENSITY.....	29
4.5	CONDUCTED BAND EDGE AND SPURIOUS EMISSION	32
4.6	RADIATION BANDEDGE AND SPURIOUS EMISSION	36
	APPENDIX A - PHOTOGRAPHS OF EUT.....	A-1

1. GENERAL INFORMATION

1.1 EUT INFORMATION

Applicant	ZEBEX INDUSTRIES INC. B1F.-1, No. 207, Sec. 3, Beixin Rd, Xindian Dist, New Taipei City 23143, Taiwan
Manufacturer	ZEBEX INDUSTRIES INC. B1F.-1, No. 207, Sec. 3, Beixin Rd, Xindian Dist, New Taipei City 23143, Taiwan
Equipment	Wireless Handheld Barcode Scanner
Model	Z-3190BT Plus, Z-3192BT Plus
Model Discrepancy	Z-3190BT Plus: CCD Wireless Handheld Barcode Scanner Z-3192BT Plus: 2D Image Wireless Handheld Barcode Scanner
Brand Name	ZEBEX
Received Date	February 22, 2024
Date of Test	June 28 ~ July 1, 2024
Power Supply	Power from Adapter BILLION / BA018-050200HXX I/P: 100-240VAC, 0.5A, 50/60Hz O/P: 5.0VDC, 2.0A
EUT Serial #	P90PH000001
HW Version	023-190BP1-034 & 023-190BP2-034 & 023-190BP3-034
SW Version	Z-3190BT Plus: Z-3190BT+(H02.x0) 09:27:50 Date:11/28/2023 Z-3192BT Plus: Z-3192BT+(M01.03) Ver:01.00 Jul 11 2024 SN:20240319 BT Controller(H02.B2) BT0103 Jul 12 2024

Remark:

- For more details, please refer to the User's manual of the EUT.
- Disclaimer: Antenna information is provided by the applicant, test results of this report are applicable to the sample EUT received.
- Disclaimer: Variant information between/among model numbers / trademarks are provided by the applicant, test results of this report are applicable to the sample EUT received of main test model name.)

1.2 EUT CHANNEL INFORMATION

Frequency Range	2402MHz-2480MHz
Modulation Type	GFSK for BLE 1 Mbps GFSK for BLE 2 Mbps
Number of channel	40 Channels

Remark:

Refer as ANSI C63.10: 2013 clause 5.6.1 Table 4 for test channels

Number of frequencies to be tested		
Frequency range in which device operates	Number of frequencies	Location in frequency range of operation
<input type="checkbox"/> 1 MHz or less	1	Middle
<input type="checkbox"/> 1 MHz to 10 MHz	2	1 near top and 1 near bottom
<input checked="" type="checkbox"/> More than 10 MHz	3	1 near top, 1 near middle, and 1 near bottom

1.3 ANTENNA INFORMATION

Antenna Type	<input type="checkbox"/> PIFA <input type="checkbox"/> PCB <input type="checkbox"/> Dipole <input checked="" type="checkbox"/> Chip
Antenna Gain	Gain: 2.13 dBi
Antenna Connector	N/A

Notes:

1.The antenna(s) of the EUT are permanently attached and there are no provisions for connection to an external antenna. So the EUT complies with the requirements of §15.203.

1.4 MEASUREMENT UNCERTAINTY

PARAMETER	UNCERTAINTY
AC Powerline Conducted Emission	± 2.213 dB
Channel Bandwidth	± 2.7 %
RF output power (Power Meter + Power sensor)	± 0.243 dB
Power Spectral density	± 2.739 dB
Conducted Bandedge	± 2.739 dB
Conducted Spurious Emission	± 2.742 dB
Radiated Emission_9kHz-30MHz	± 3.761 dB
Radiated Emission_30MHz-200MHz	± 3.473 dB
Radiated Emission_200MHz-1GHz	± 3.946 dB
Radiated Emission_1GHz-6GHz	± 4.797 dB
Radiated Emission_6GHz-18GHz	± 4.803 dB
Radiated Emission_18GHz-26GHz	± 3.459 dB
Radiated Emission_26GHz-40GHz	± 3.297 dB

Remark:

- 1.This uncertainty represents an expanded uncertainty expressed at approximately the 95% confidence level using a coverage factor of k=2
2. ISO/IEC 17025 requires that an estimate of the measurement uncertainties associated with the emissions test results be included in the report.

1.5 FACILITIES AND TEST LOCATION

All measurement facilities used to collect the measurement data are located at

No.11, Wugong 6th Rd., Wugu Dist., New Taipei City, Taiwan.

CAB identifier: TW1309

Test site	Test Engineer	Remark
AC Conduction Room	Ben Yang	-
Radiation	Tony Chao · Ray Li	-
RF Conducted	Marco Chan	-

Remark: The lab has been recognized as the FCC accredited lab. under the KDB 974614 D01 and is listed in the FCC pubic Access Link (PAL) database, FCC Registration No. :444940, the FCC Designation No.:TW1309

1.6 INSTRUMENT CALIBRATION

Conducted_FCC/IC/NCC (All)					
Name of Equipment	Manufacturer	Model	Serial Number	Calibration Date	Calibration Due
Power Sensor	Anritsu	MA2411B	1911387	2023-07-25	2024-07-24
Power Meter	Anritsu	ML2496A	2136002	2023-11-16	2024-11-15
EXA Signal Analyzer	Keysight	N9010A	MY54200716	2023-10-13	2024-10-12
EXA Signal Analyzer	Keysight	N9030B	MY62291089	2023-10-13	2024-10-12
Software	Radio Test Software Ver. 21 & E3-Ver: 6.11-20180413				

966A Radiated					
Name of Equipment	Manufacturer	Model	Serial Number	Calibration Date	Calibration Due
Signal Analyzer	KEYSIGHT	N9010A	MY52220817	2024-03-15	2025-03-14
Thermo-Hygro Meter	WISEWIND	1206	D07	2023-12-08	2024-12-07
Active Loop Antenna	SCHWARZBECK	FMZB 1513-60	1513-60-028	2023-12-13	2024-12-12
Bi-Log Antenna	Sunol Sciences	JB3	A030105	2023-08-08	2024-08-07
Preamplifier	EMEC	EM330	060609	2024-02-21	2025-02-20
Cable	Huber+Suhner	104PEA	20995+21000+182330	2024-02-21	2025-02-20
Horn Antenna	ETC	MCTD 1209	DRH13M02003	2023-12-28	2024-12-27
Preamplifier	HP	8449B	3008A00965	2023-12-22	2024-12-21
Cable	EMCI	EMC101G	221213+221011+221012	2023-10-17	2024-10-16
Attenuator	Mini-Circuits	BW-S9W5	BWS9W5-09-966A-01	2024-02-07	2025-02-06
High Pass Filters	Titan Microwave	T04H30001800070S01	22011402-4	2024-06-12	2025-06-13
Horn Antenna	SCHWARZBECK	BBHA9170	1047	2023-12-13	2024-12-12
Pre-Amplifier	EMCI	EMC184045SE	980860	2023-12-12	2024-12-11
Turn Table	CCS	CC-T-1F	N/A	N.C.R	N.C.R
Controller	CCS	CC-C-1F	N/A	N.C.R	N.C.R
Antenna Tower	CCS	CC-A-1F	N/A	N.C.R	N.C.R
Site Validation	CCS	966A	N/A	2023-07-10	2024-07-09
Software	e3 V9-210616c				

Remark:

1. Each piece of equipment is scheduled for calibration once a year.
2. N.C.R. = No Calibration Required.

AC Mains Conduction					
Name of Equipment	Manufacturer	Model	Serial Number	Calibration Date	Calibration Due
EMI Test Receiver	R&S	ESCI	100064	2024-06-14	2025-06-13
LISN	TESEQ	LN2-16N	22012	2024-02-29	2025-02-27
Cable	EMCI	CFD300-NL	CERF	2024-06-27	2025-06-26
Software	e3 V6-110812				

Remark:

1. Each piece of equipment is scheduled for calibration once a year.
2. N.C.R. = No Calibration Required.

1.7 SUPPORT AND EUT ACCESSORIES EQUIPMENT

EUT Accessories Equipment					
No.	Equipment	Brand	Model	Series No.	FCC ID
	N/A				

Support Equipment (Conducted)					
No.	Equipment	Brand	Model	Series No.	FCC ID
1	NB(L)	Lenovo	X260	N/A	N/A
2	Micro to USB Cable	Pro-Best	MK-USB-MIN5MBM-100	N/A	N/A
A	USB to Type C Cable	WHALETURN	USB A/M TO Type C/M L=1.5M	N/A	N/A
B	Adapter	BILLION	BA018-050200HXX	N/A	N/A

Support Equipment (Conduction)					
No.	Equipment	Brand	Model	Series No.	FCC ID
1	NB(D)	Lenovo	ThinkPad X260	N/A	N/A
2	Adapter	BILLION	BA018-050200HXX	N/A	N/A
3	Micro to USB Cable	Pro-Best	MK-USB-MIN5MBM-100	N/A	N/A
A	Type C Cable	WHALETURN	USB A/M TO Type C/M L=1.5M	N/A	N/A

Support Equipment (RSE)					
No.	Equipment	Brand	Model	Series No.	FCC ID
1	NB(D)	Lenovo	ThinkPad X260	N/A	N/A
2	Adapter	Lenovo	ADLX45DLC3A	N/A	N/A
3	Micro to USB Cable	Smays	SMAYS-6FT	N/A	N/A
A	Adapter	BILLION	BA018-050200HXX	N/A	N/A
B	Type C Cable	WHALETURN	USB A/M TO Type C/M L=1.5M	N/A	N/A

1.8 TEST SET UP DIAGRAM

Conducted:

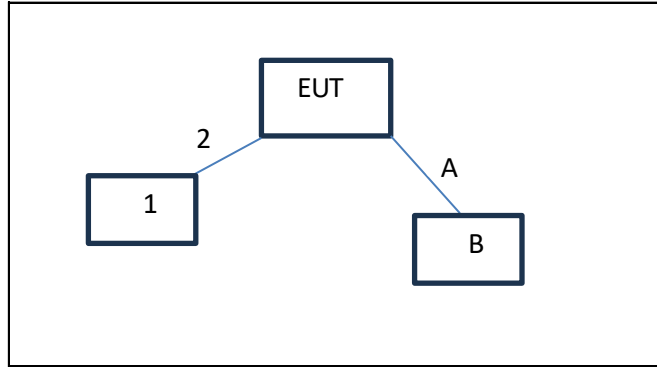

RSE:

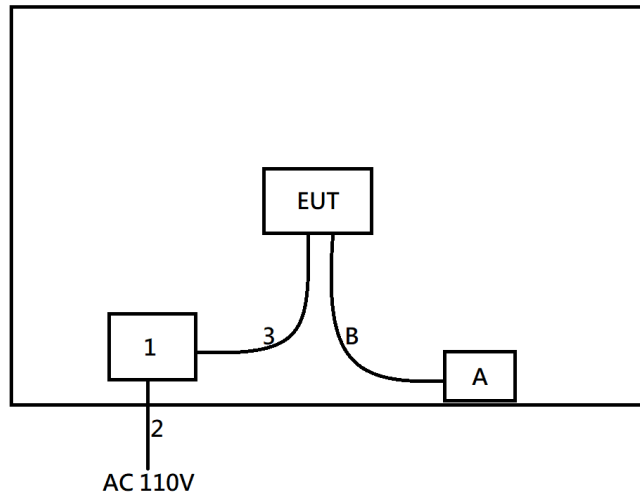

1.9 TEST METHODOLOGY AND APPLIED STANDARDS

The test methodology, setups and results comply with all requirements in accordance with ANSI C63.10:2013, FCC Part 2, FCC Part 15.247, KDB 558074.

2. TEST SUMMERY

FCC Standard Section	Report Section	Test Item	Result
15.203	1.3	Antenna Requirement	Pass
15.207(a)	4.1	AC Conducted Emission	Pass
15.247(a)(2)	4.2	6 dB Bandwidth	Pass
-	4.2	Occupied Bandwidth (99%)	Pass
15.247(b)(3)	4.3	Output Power Measurement	Pass
15.247(e)	4.4	Power Spectral Density	Pass
15.247(d)	4.5	Conducted Band Edge	Pass
15.247(d)	4.5	Conducted Spurious Emission	Pass
15.247(d) 15.205, 15.209	4.6	Radiation Band Edge	Pass
15.247(d) 15.205, 15.209	4.6	Radiation Spurious Emission	Pass

3. DESCRIPTION OF TEST MODES

3.1 THE WORST MODE OF OPERATING CONDITION

Operation mode	BLE Mode (1Mbps) BLE Mode (2Mbps)
Test Channel Frequencies	1.Lowest Channel : 2402MHz 2.Middle Channel : 2442MHz 3.Highest Channel : 2480MHz

Remark:

1. EUT pre-scanned data rate of output power for each mode, the worst data rate were recorded in this report.

3.2 THE WORST MODE OF MEASUREMENT

AC Power Line Conducted Emission	
Test Condition	AC Power line conducted emission for line and neutral
Power supply Mode	Mode 1: EUT Power by Adapter
Worst Mode	<input checked="" type="checkbox"/> Mode 1 <input type="checkbox"/> Mode 2 <input type="checkbox"/> Mode 3 <input type="checkbox"/> Mode 4

Radiated Emission Measurement Above 1G	
Test Condition	Radiated Emission Above 1G
Power supply Mode	Mode 1: EUT power by Adapter
Worst Mode	<input checked="" type="checkbox"/> Mode 1 <input type="checkbox"/> Mode 2 <input type="checkbox"/> Mode 3 <input type="checkbox"/> Mode 4
Worst Position	<input type="checkbox"/> Placed in fixed position. <input type="checkbox"/> Placed in fixed position at X-Plane (E2-Plane) <input checked="" type="checkbox"/> Placed in fixed position at Y-Plane (E1-Plane) <input type="checkbox"/> Placed in fixed position at Z-Plane (H-Plane)

Radiated Emission Measurement Below 1G	
Test Condition	Radiated Emission Below 1G
Power supply Mode	Mode 1: EUT power by Adapter
Worst Mode	<input checked="" type="checkbox"/> Mode 1 <input type="checkbox"/> Mode 2 <input type="checkbox"/> Mode 3 <input type="checkbox"/> Mode 4

Remark:

1. The worst mode was record in this test report.
2. EUT pre-scanned in three axis ,X,Y, Z and two polarity, for radiated measurement. The worst case(Y-Plane) were recorded in this report
3. AC power line conducted emission and for below 1G radiation emission were performed the EUT transmit at the highest output power channel as worse case.

3.3 EUT DUTY CYCLE

Temperature: 23.2°C

Test date: June 28, 2024

Humidity: 57% RH

Tested by: Marco Chan

	Duty Cycle (%) = Ton / (Ton+Toff)	Duty Factor (dB) =10*log (1/Duty Cycle)	1/T (kHz)	VBW setting (kHz)
BLE 1M	63.20	1.99	2.53	3.00
BLE 2M	33.60	4.74	4.76	5.00

BLE_1M_LowCH00-2402

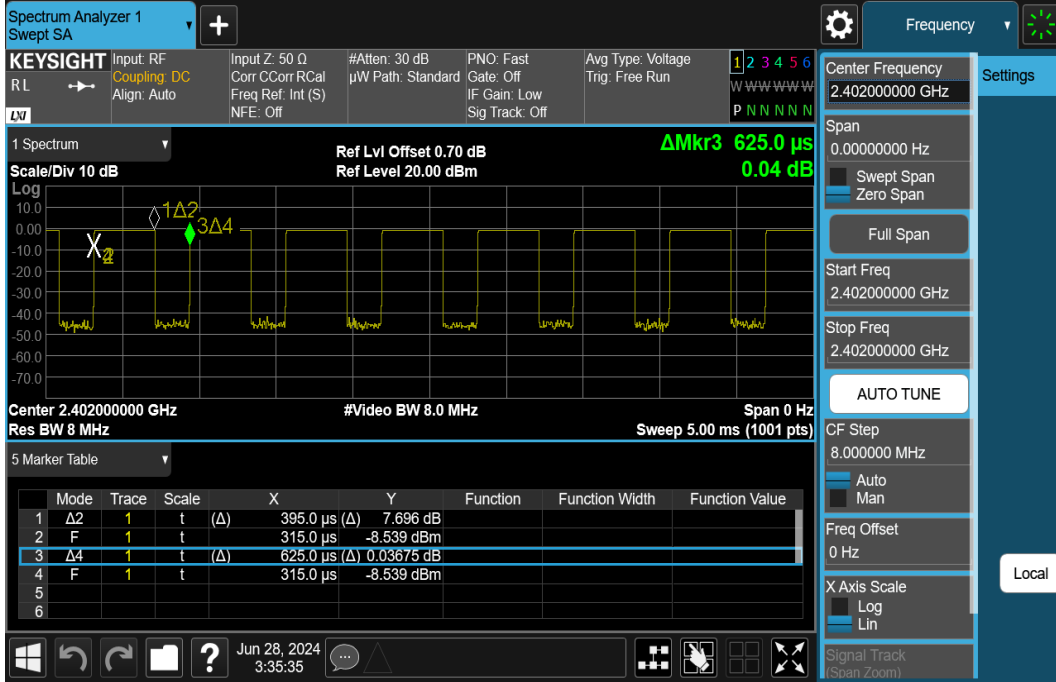

BLE_2M_LowCH00-2402

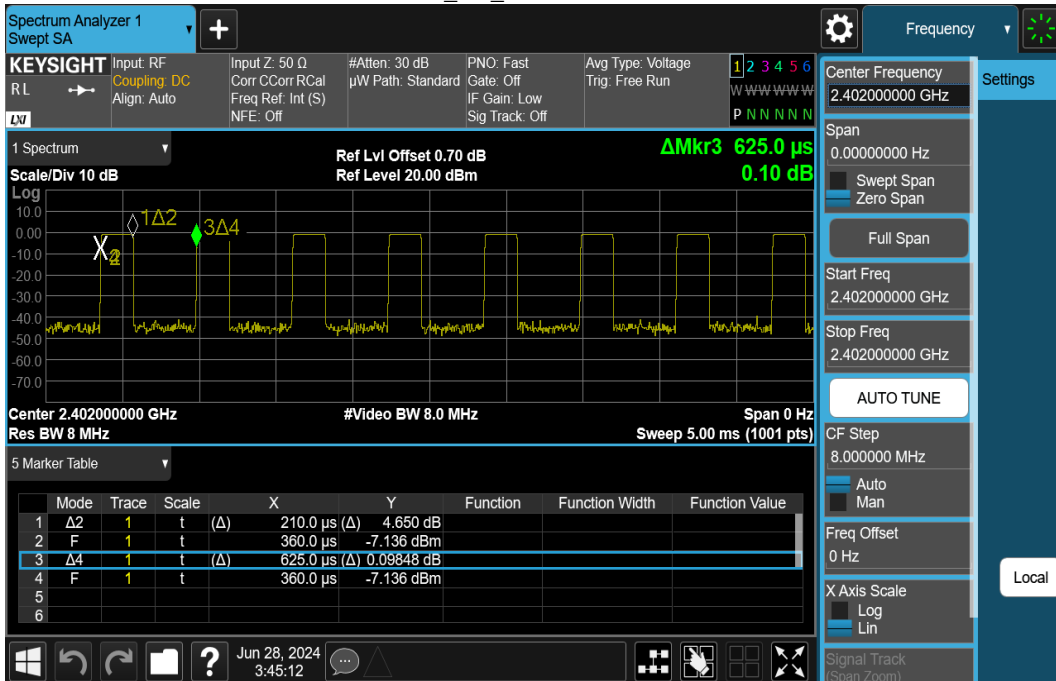

4. TEST RESULT

4.1 AC POWER LINE CONDUCTED EMISSION

4.1.1 Test Limit

According to §15.207(a),

Frequency Range (MHz)	Limits(dB μ V)	
	Quasi-peak	Average
0.15 to 0.50	66 to 56*	56 to 46*
0.50 to 5	56	46
5 to 30	60	50

* Decreases with the logarithm of the frequency.

4.1.2 Test Procedure

Test method Refer as ANSI C63.10: 2013 clause 6.2,

1. The EUT was placed on a non-conducted table, which is 0.8m above horizontal ground plane and 0.4m above vertical ground plane.
2. EUT connected to the line impedance stabilization network (LISN)
3. Receiver set RBW of 9kHz and Detector Peak, and note as quasi-peak and average.
4. Maximum procedure was performed on the six highest emissions to ensure EUT compliance.
5. Recorded Line for Neutral and Line.

4.1.3 Test Setup

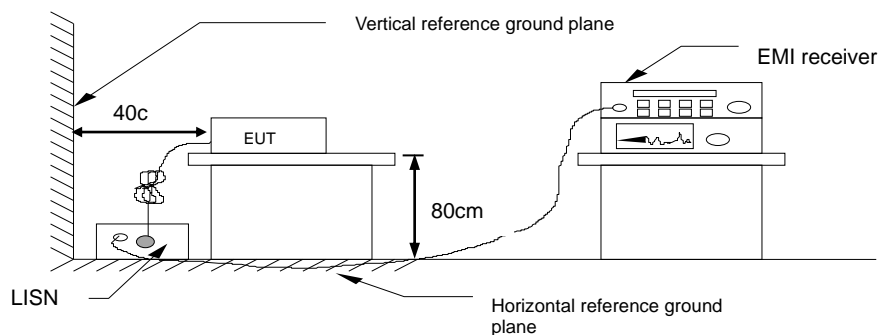

4.1.4 Test Result

Project No	: TM-2402000257P	Test Date	: 2024-06-28
Operation Mode	: BLE	Temp./Humi.	: 23.4°C / 54%
Test Chamber	: Conduction	Engineer	: Ben Yang
Probe	: LINE	Test Voltage	: AC 120V/60Hz
Note	:		

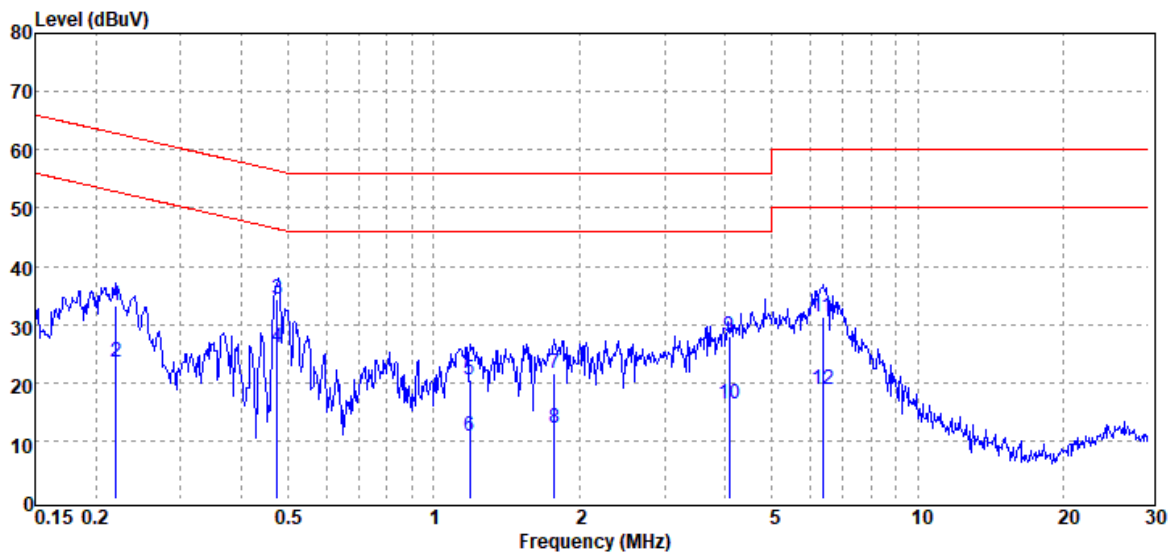

Freq. MHz	Detector Mode PK/QP/AV	Spectrum Read Level dBuV	Factor dB	Actual FS dBuV	Limit dBuV	Margin dB
0.221	QP	33.19	0.12	33.31	62.79	-29.48
0.221	Average	23.41	0.12	23.53	52.79	-29.26
0.476	QP	34.23	0.11	34.34	56.42	-22.08
0.476	Average	25.94	0.11	26.05	46.42	-20.37
1.185	QP	20.44	0.12	20.56	56.00	-35.44
1.185	Average	10.71	0.12	10.83	46.00	-35.17
1.774	QP	21.48	0.15	21.63	56.00	-34.37
1.774	Average	12.05	0.15	12.20	46.00	-33.80
4.083	QP	27.71	0.21	27.92	56.00	-28.08
4.083	Average	16.14	0.21	16.35	46.00	-29.65
6.372	QP	30.91	0.27	31.18	60.00	-28.82
6.372	Average	18.45	0.27	18.72	50.00	-31.28

Note: 1. Actual FS= Spectrum Read Level + Factor

Note: 2. Margin= Actual FS - Limit

Report No.: TMWK2406002111KR

Project No : TM-2402000257P
 Operation Mode : BLE
 Test Chamber : Conduction
 Probe : NEUTRAL
 Note :

Test Date : 2024-06-28
 Temp./Humi. : 23.4°C / 54%
 Engineer : Ben Yang
 Test Voltage : AC 120V/60Hz

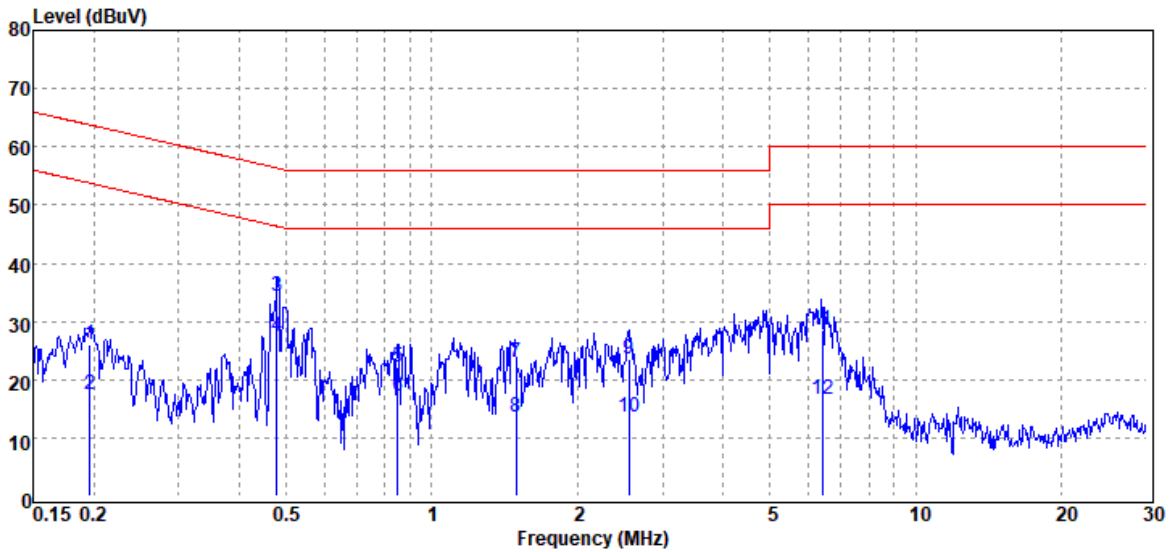

Freq. MHz	Detector Mode PK/QP/AV	Spectrum Read Level dB μ V	Factor dB	Actual FS dB μ V	Limit dB μ V	Margin dB
0.196	QP	25.91	0.09	26.00	63.77	-37.77
0.196	Average	17.36	0.09	17.45	53.77	-36.32
0.479	QP	34.19	0.08	34.27	56.36	-22.09
0.479	Average	27.44	0.08	27.52	46.36	-18.84
0.852	QP	22.12	0.09	22.21	56.00	-33.79
0.852	Average	16.94	0.09	17.03	46.00	-28.97
1.492	QP	22.98	0.11	23.09	56.00	-32.91
1.492	Average	13.57	0.11	13.68	46.00	-32.32
2.557	QP	23.49	0.15	23.64	56.00	-32.36
2.557	Average	13.34	0.15	13.49	46.00	-32.51
6.402	QP	28.37	0.24	28.61	60.00	-31.39
6.402	Average	16.28	0.24	16.52	50.00	-33.48

Note: 1. Actual FS= Spectrum Read Level + Factor

Note: 2. Margin= Actual FS - Limit

Report No.: TMWK2406002111KR

Project No : TM-2402000257P
 Operation Mode : BLE
 Test Chamber : Conduction
 Probe : LINE
 Note :

Test Date : 2024-07-01
 Temp./Humi. : 23.4°C / 54%
 Engineer : Ben Yang
 Test Voltage : AC 240V/60Hz

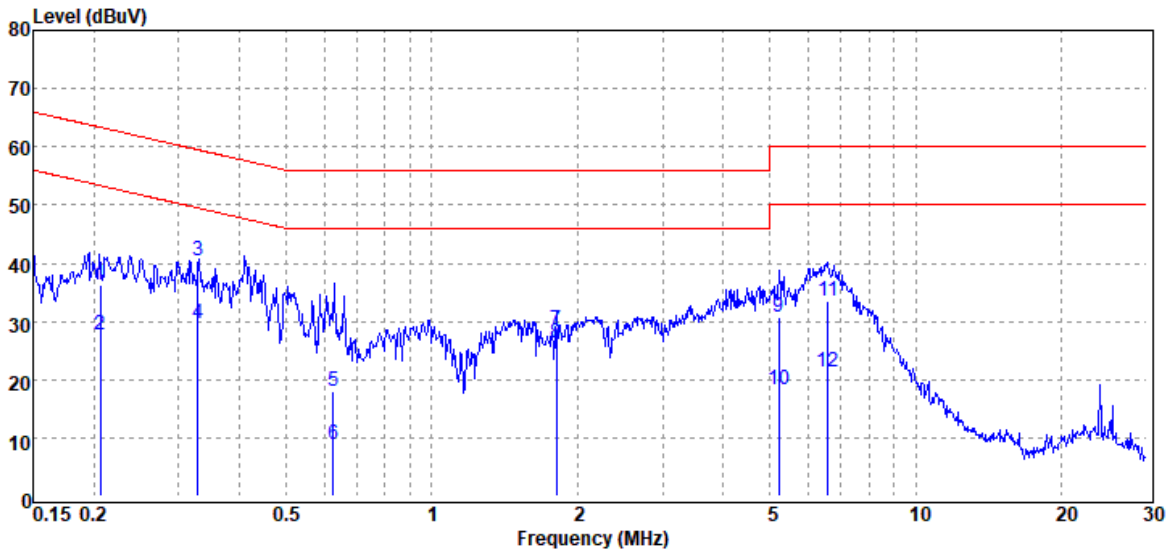

Freq. MHz	Detector Mode PK/QP/AV	Spectrum Read Level dB μ V	Factor dB	Actual FS dB μ V	Limit dB μ V	Margin dB
0.207	QP	36.15	0.12	36.27	63.34	-27.07
0.207	Average	27.64	0.12	27.76	53.34	-25.58
0.329	QP	40.40	0.11	40.51	59.48	-18.97
0.329	Average	29.61	0.11	29.72	49.48	-19.76
0.626	QP	17.93	0.11	18.04	56.00	-37.96
0.626	Average	8.72	0.11	8.83	46.00	-37.17
1.813	QP	28.48	0.15	28.63	56.00	-27.37
1.813	Average	26.06	0.15	26.21	46.00	-19.79
5.206	QP	30.41	0.23	30.64	60.00	-29.36
5.206	Average	18.00	0.23	18.23	50.00	-31.77
6.584	QP	33.15	0.27	33.42	60.00	-26.58
6.584	Average	20.97	0.27	21.24	50.00	-28.76

Note: 1. Actual FS= Spectrum Read Level + Factor

Note: 2. Margin= Actual FS - Limit

Report No.: TMWK2406002111KR

Project No : TM-2402000257P
 Operation Mode : BLE
 Test Chamber : Conduction
 Probe : NEUTRAL
 Note :

Test Date : 2024-07-01
 Temp./Humi. : 23.4°C / 54%
 Engineer : Ben Yang
 Test Voltage : AC 240V/60Hz

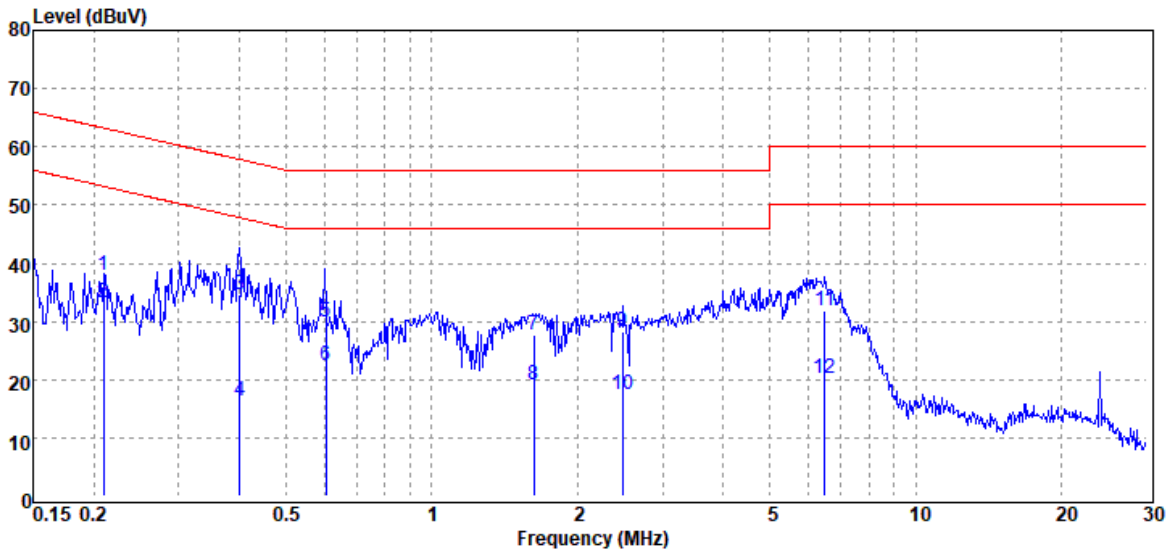

Freq. MHz	Detector Mode PK/QP/AV	Spectrum Read Level dB μ V	Factor dB	Actual FS dB μ V	Limit dB μ V	Margin dB
0.210	QP	37.80	0.09	37.89	63.22	-25.33
0.210	Average	33.13	0.09	33.22	53.22	-20.00
0.401	QP	34.63	0.08	34.71	57.82	-23.11
0.401	Average	16.21	0.08	16.29	47.82	-31.53
0.604	QP	29.68	0.08	29.76	56.00	-26.24
0.604	Average	22.46	0.08	22.54	46.00	-23.46
1.624	QP	27.46	0.11	27.57	56.00	-28.43
1.624	Average	19.08	0.11	19.19	46.00	-26.81
2.474	QP	28.05	0.15	28.20	56.00	-27.80
2.474	Average	17.42	0.15	17.57	46.00	-28.43
6.486	QP	31.62	0.24	31.86	60.00	-28.14
6.486	Average	19.86	0.24	20.10	50.00	-29.90

Note: 1. Actual FS= Spectrum Read Level + Factor

Note: 2. Margin= Actual FS - Limit

4.2 6dB BANDWIDTH AND OCCUPIED BANDWIDTH(99%)

4.2.1 Test Limit

According to §15.247(a)(2),

6 dB Bandwidth :

Limit	Shall be at least 500kHz
-------	--------------------------

Occupied Bandwidth(99%) : For reporting purposes only.

4.2.2 Test Procedure

Test method Refer as KDB 558074 D01 and ANSI C63.10: 2013 clause 6.9.2.

1. The EUT RF output connected to the spectrum analyzer by RF cable.
2. Setting maximum power transmit of EUT
3. SA set RBW = 100kHz, VBW = 300kHz and Detector = Peak, to measurement 6 dB Bandwidth.
4. SA set RBW = 1% ~ 5% OBW, VBW = three times the RBW and Detector = Peak, to measurement 99% Bandwidth
5. Measure and record the result of 6 dB Bandwidth and 99% Bandwidth. in the test report.

4.2.3 Test Setup

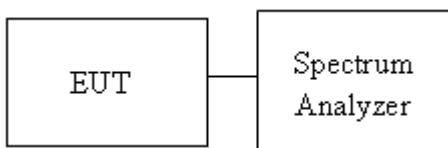

4.2.4 Test Result

Temperature: 23.2°C

Test date: June 28, 2024

Humidity: 57% RH

Tested by: Marco Chan

6dB BANDWIDTH

BLE 1M mode

Frequency (MHz)	6dB BW (MHz)	Required BW (MHz)	Result
2402	0.7284	≥ 0.5	PASS
2442	0.7237	≥ 0.5	PASS
2480	0.7152	≥ 0.5	PASS

BLE 2M mode

Frequency (MHz)	6dB BW (MHz)	Required BW (MHz)	Result
2402	1.266	≥ 0.5	PASS
2442	1.263	≥ 0.5	PASS
2480	1.262	≥ 0.5	PASS

BANDWIDTH 99%

BLE 1M mode

Frequency (MHz)	99%Bandwidth (MHz)
2402	1.0342
2442	1.0324
2480	1.0308

BLE 2M mode

Frequency (MHz)	99%Bandwidth (MHz)
2402	2.0716
2442	2.0708
2480	2.0704

Test Data

6dB BANDWIDTH

OBW_BLE 1M_LowCH00-2402MHz

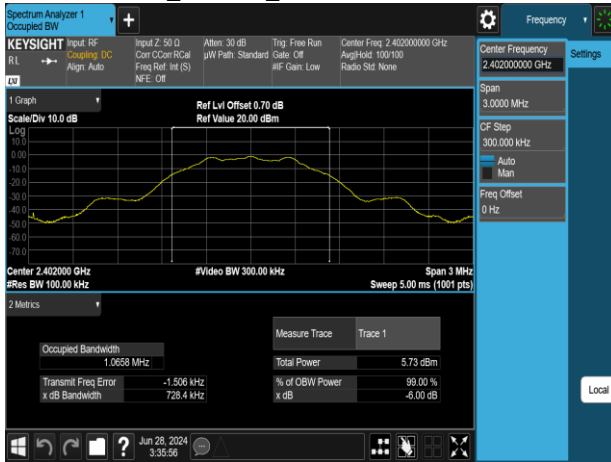

OBW_BLE 2M_LowCH00-2402MHz



OBW_BLE 1M_MidCH20-2442MHz



OBW_BLE 2M_MidCH20-2442MHz



OBW_BLE 1M_HighCH39-2480MHz

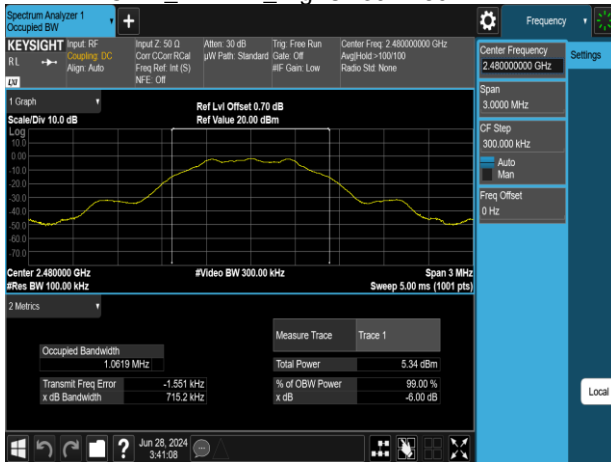

OBW_BLE 2M_HighCH39-2480MHz

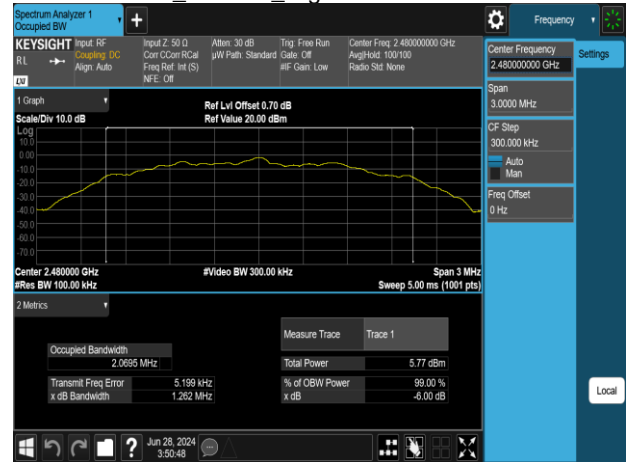

Report No.: TMWK2406002111KR

BANDWIDTH 99%

IC OBW_BLE 1M_LowCH00-2402MHz

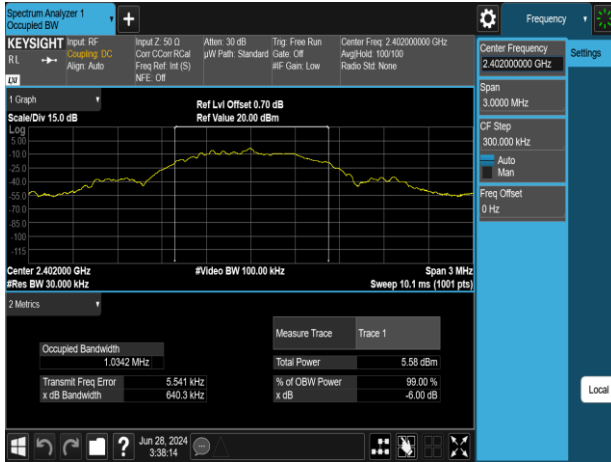

IC OBW_BLE 2M_LowCH00-2402MHz

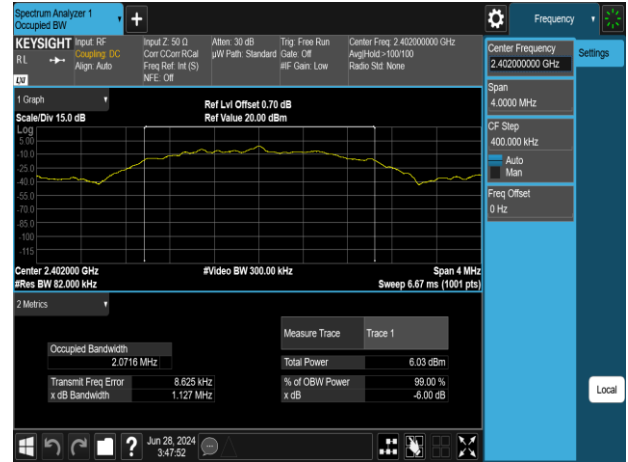

IC OBW_BLE 1M_MidCH20-2442MHz



IC OBW_BLE 2M_MidCH20-2442MHz

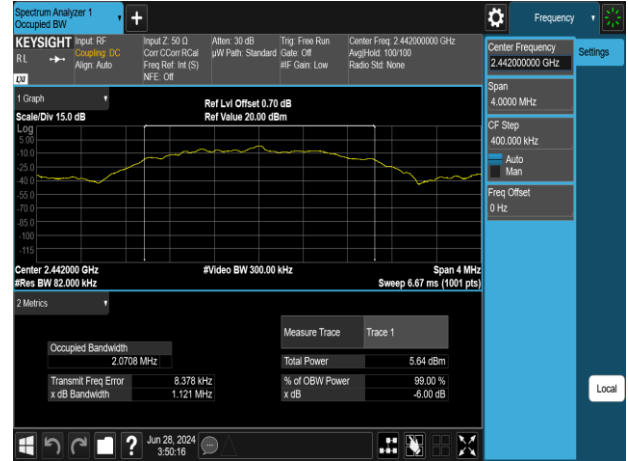

IC OBW_BLE 1M_HighCH39-2480MHz



IC OBW_BLE 2M_HighCH39-2480MHz

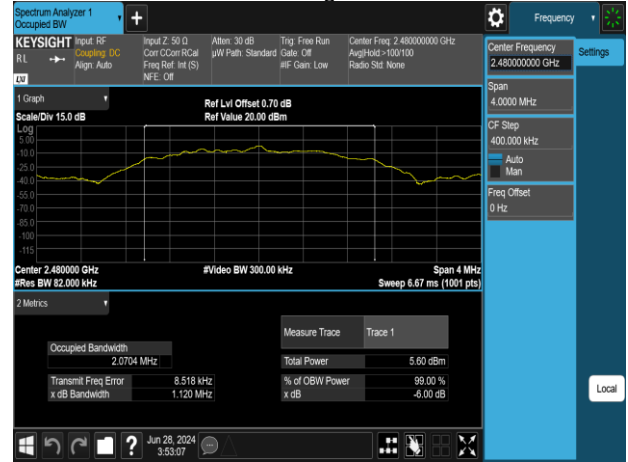

4.3 OUTPUT POWER MEASUREMENT

4.3.1 Test Limit

According to §15.247(b)(3),

Peak output power :

FCC

For systems using digital modulation in the 902-928 MHz, 2400-2483.5 MHz, and 5725-5850 MHz bands: 1 Watt.

Average output power : For reporting purposes only.

4.3.2 Test Procedure

Test method Refer as KDB 558074 D01

1. The EUT RF output connected to the power meter by RF cable.
2. Setting maximum power transmit of EUT.
3. The path loss was compensated to the results for each measurement.
4. Measure and record the result of Peak output power and Average output power. in the test report.

4.3.3 Test Setup

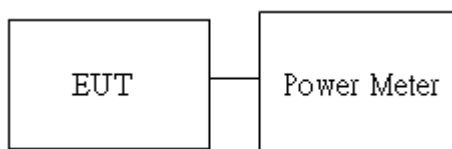

4.3.4 Test Result

Temperature: 23.2°C

Test date: June 28, 2024

Humidity: 57% RH

Tested by: Marco Chan

Peak & Average output power :

BLE 1M mode:

CH	Frequency (MHz)	Power Setting	Peak Output Power (dBm)	Required Limit (dBm)
Low	2402	default	-0.82	30
Mid	2442	default	-1.11	30
High	2480	default	-1.35	30
CH	Frequency (MHz)	Power Setting	Avg. Output Power (dBm)	Required Limit (dBm)
Low	2402	default	-0.92	30
Mid	2442	default	-1.23	30
High	2480	default	-1.46	30

***Note:**

1. Measured by power meter, cable loss 0.7 dB + Duty cycle factor has been offsetted to the power meter for Avg. power and cable loss has been offsetted for Peak power measurement.

BLE 2M mode:

CH	Frequency (MHz)	Power set	Peak Output Power (dBm)	Required Limit (dBm)
Low	2402	default	-0.83	30
Mid	2442	default	-1.12	30
High	2480	default	-1.36	30
CH	Frequency (MHz)	Power set	Avg. Output Power (dBm)	Required Limit (dBm)
Low	2402	default	-0.89	30
Mid	2442	default	-1.16	30
High	2480	default	-1.40	30

***Note:**

1. Measured by power meter, cable loss 0.7 dB + Duty cycle factor has been offsetted to the power meter for Avg. power and cable loss has been offsetted for Peak power measurement.

4.4 POWER SPECTRAL DENSITY

4.4.1 Test Limit

According to §15.247(e) ,

For digitally modulated systems, the power spectral density conducted from the intentional radiator to the antenna shall not be greater than 8 dBm in any 3 kHz band during any time interval of continuous transmission.

Limit	<input checked="" type="checkbox"/> Antenna not exceed 6 dBi : 8dBm <input type="checkbox"/> Antenna with DG greater than 6 dBi [Limit = 8 – (DG – 6)] <input type="checkbox"/> Point-to-point operation :
-------	---

4.4.2 Test Procedure

Test method Refer as KDB 558074 D01

1. The EUT RF output connected to the spectrum analyzer by RF cable.
2. Setting maximum power transmit of EUT
3. SA set RBW = 3kHz, VBW = 10kHz, Span = 1.5 times DTS Bandwidth (6 dB BW), Detector = Peak, Sweep Time = Auto and Trace = Max hold.
4. The path loss was compensated to the results for each measurement by SA.
5. Mark the maximum level.
6. Measure and record the result of power spectral density. in the test report.

4.4.3 Test Setup

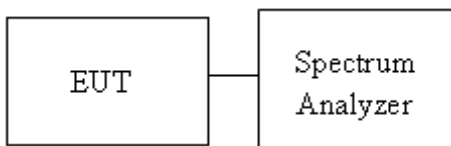

4.4.4 Test Result

Temperature: 23.2°C

Test date: June 28, 2024

Humidity: 57% RH

Tested by: Marco Chan

BLE 1M mode

Frequency (MHz)	RF Power Density (dBm/3kHz)	Maximum Limit (dBm/3kHz)	Result
2402	-16.03	8	PASS
2442	-16.44	8	PASS
2480	-16.52	8	PASS

***Note:**

1.cable loss as 0.7dB that offsets in the spectrum

BLE 2M mode

Frequency (MHz)	RF Power Density (dBm/3kHz)	Maximum Limit (dBm/3kHz)	Result
2402	-18.96	8	PASS
2442	-19.27	8	PASS
2480	-19.18	8	PASS

***Note:**

1.cable loss as 0.7dB that offsets in the spectrum

Test Data

PSD_BLE 1M_LowCH00-2402MHz

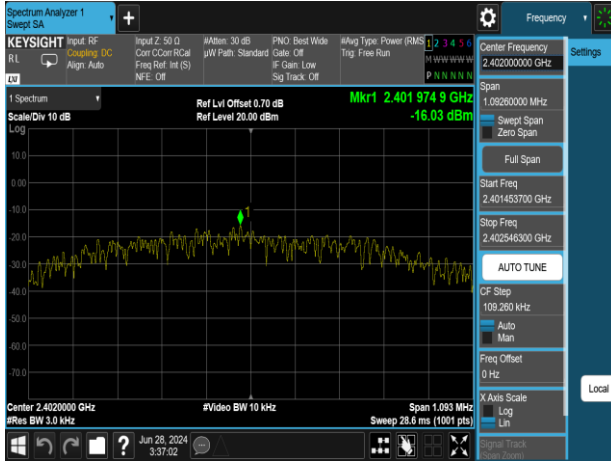

PSD_BLE 2M_LowCH00-2402MHz



PSD_BLE 1M_MidCH20-2442MHz

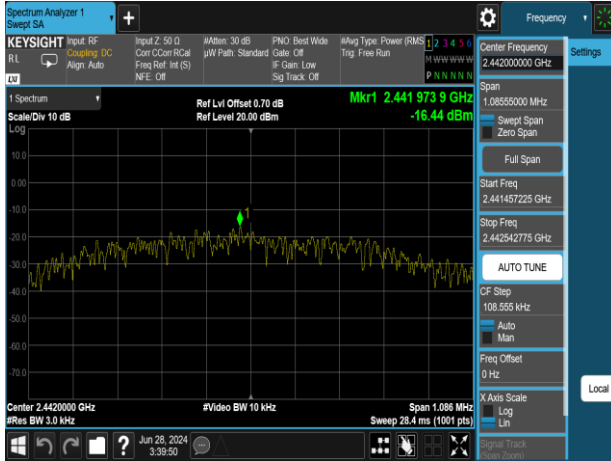

PSD_BLE 2M_MidCH20-2442MHz

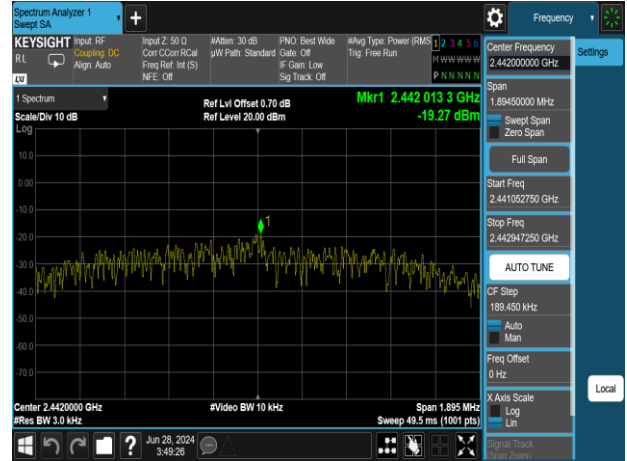

PSD_BLE 1M_HighCH39-2480MHz

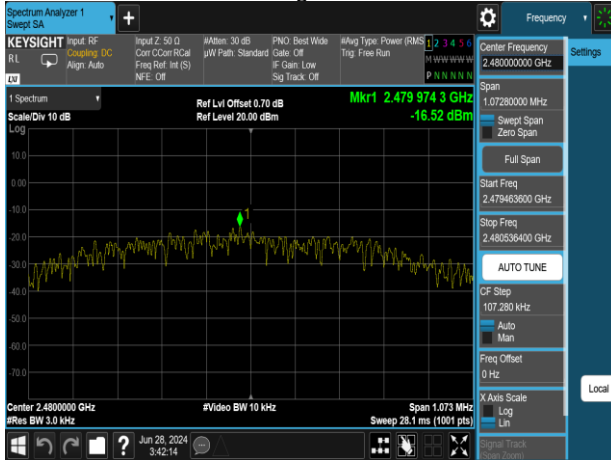

PSD_BLE 2M_HighCH39-2480MHz

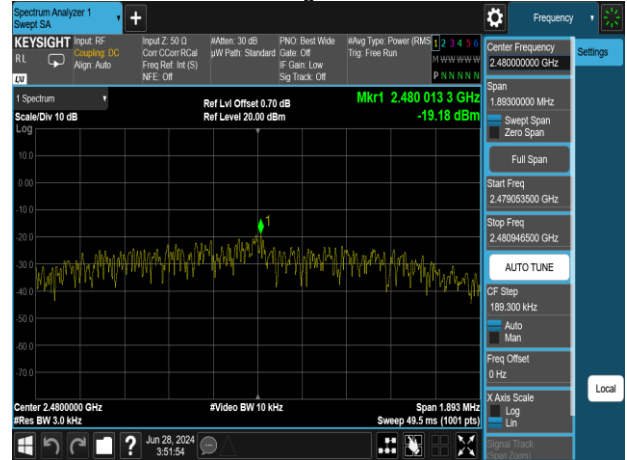

4.5 CONDUCTED BAND EDGE AND SPURIOUS EMISSION

4.5.1 Test Limit

According to §15.247(d),

FCC: In any 100 kHz bandwidth outside the authorized frequency band,

Non-restricted bands shall be attenuated at least 20 dB/30 dB relative to the maximum PSD level in 100 kHz by RF conducted or a radiated measurement which fall in the restricted bands, as defined in §15.205(a), must also comply with the radiated emission limits specified in §15.209(a).

4.5.2 Test Procedure

Test method Refer as KDB 558074 D01

1. EUT RF output port connected to the SA by RF cable, and the path loss was compensated to result.
2. SA setting, RBW=100kHz, VBW=300kHz, Detector=Peak, Trace mode = max hold, SWT = Auto.
3. In any 100 kHz bandwidth outside the authorized frequency band, shall be attenuated at least 20 dB relative to the maximum in-band peak PSD level in 100 kHz when conducted power procedure is used. If the transmitter complies with the conducted power limits based on the use of RMS averaging over a time interval, the attenuation required under this paragraph shall be 30 dB instead of 20 dB.

4.5.3 Test Setup

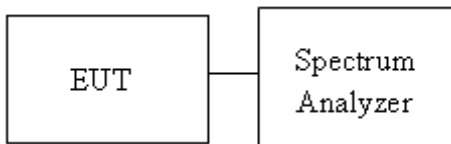

4.5.4 Test Result

Temperature: 23.2°C

Test date: June 28, 2024

Humidity: 57% RH

Tested by: Marco Chan

Report No.: TMWK2406002111KR

Test Data

Reference Level

Reference Level_BLE 1M_LowCH00-2402MHz

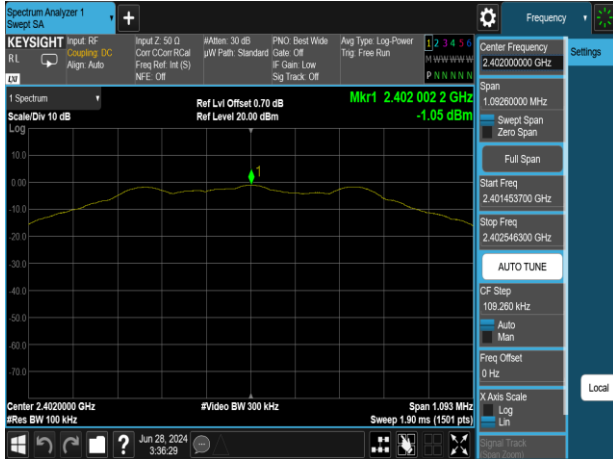

Reference Level_BLE 2M_LowCH00-2402MHz

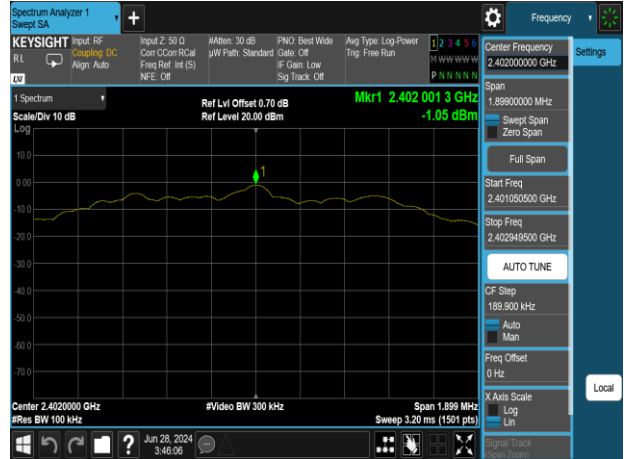

Reference Level_BLE 1M_MidCH20-2442MHz

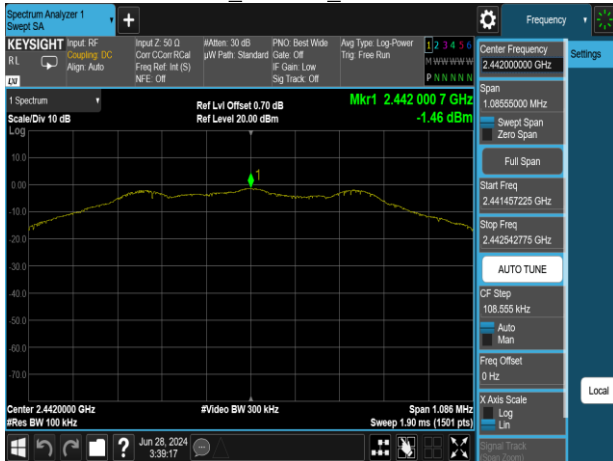

Reference Level_BLE 2M_MidCH20-2442MHz

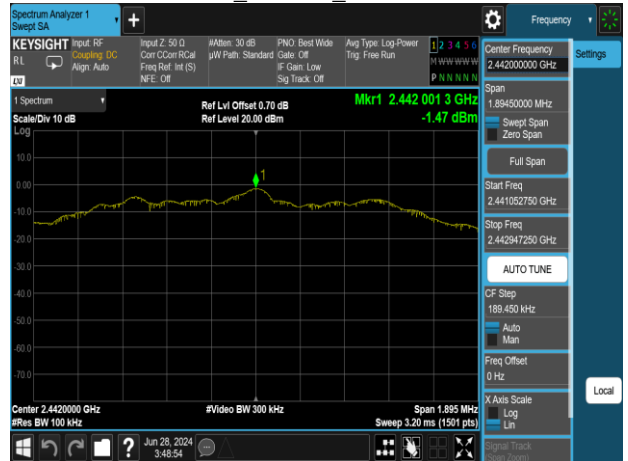

Reference Level_BLE 1M_HighCH39-2480MHz

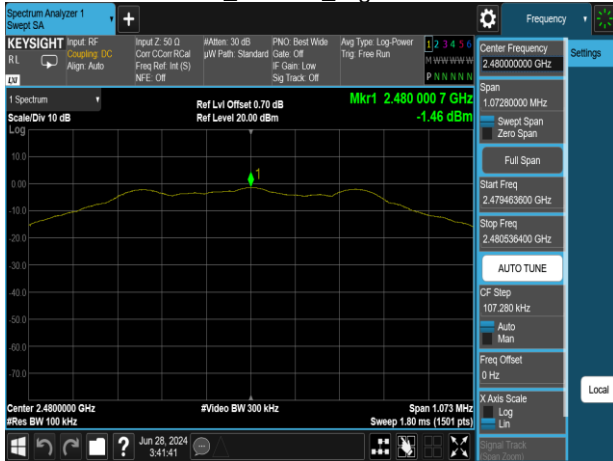

Reference Level_BLE 2M_HighCH39-2480MHz

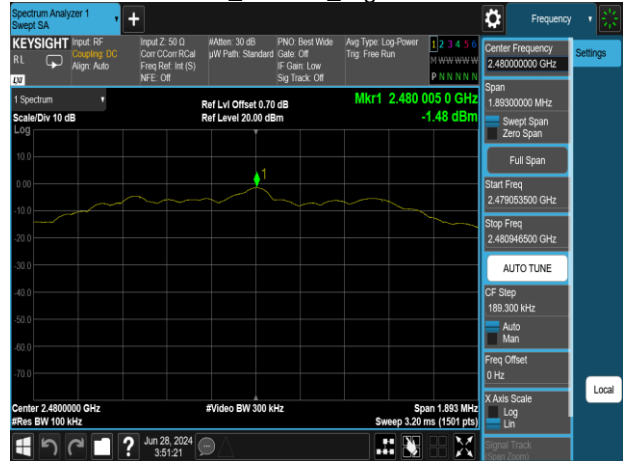

Band Edge

Band Edge_BLE 1M_LowCH00-2402MHz



Band Edge_BLE 2M_LowCH00-2402MHz

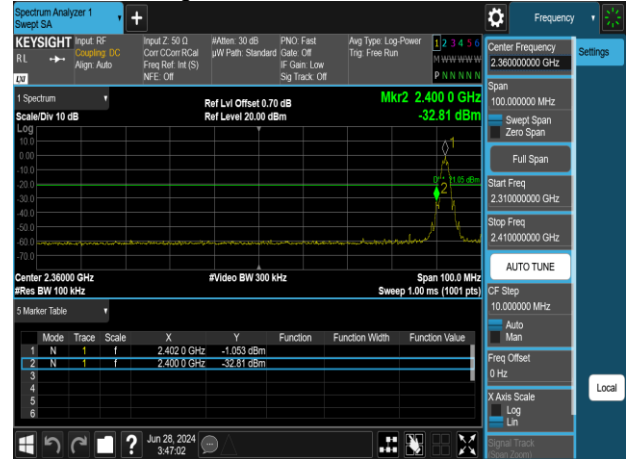

Band Edge_BLE 1M_HighCH39-2480MHz



Band Edge_BLE 2M_HighCH39-2480MHz



Report No.: TMWK2406002111KR

Spurious Emission

Spurious Emission_BLE 1M_LowCH00-2402MHz

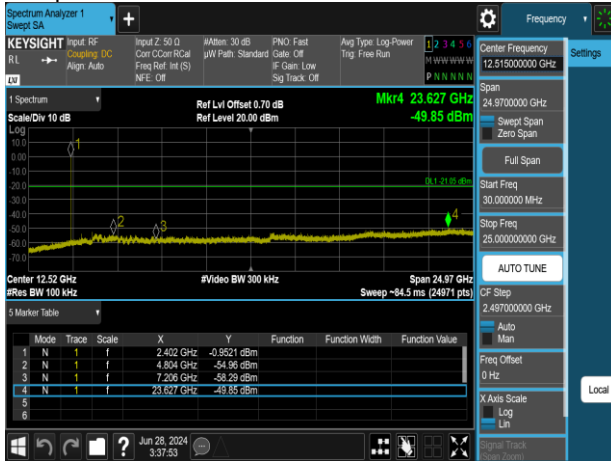

Spurious Emission_BLE 2M_LowCH00-2402MHz

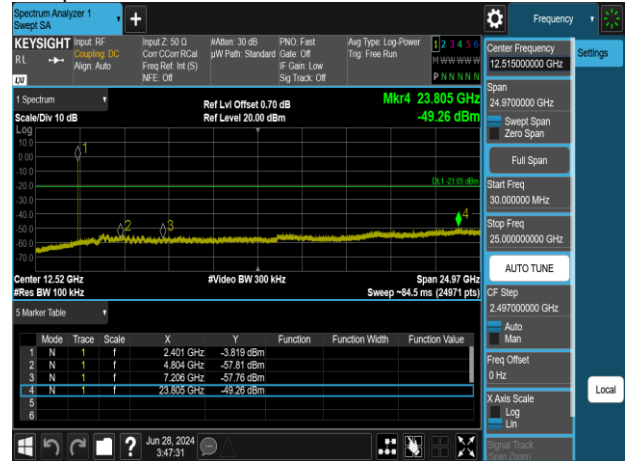

Spurious Emission_BLE 1M_MidCH20-2442MHz

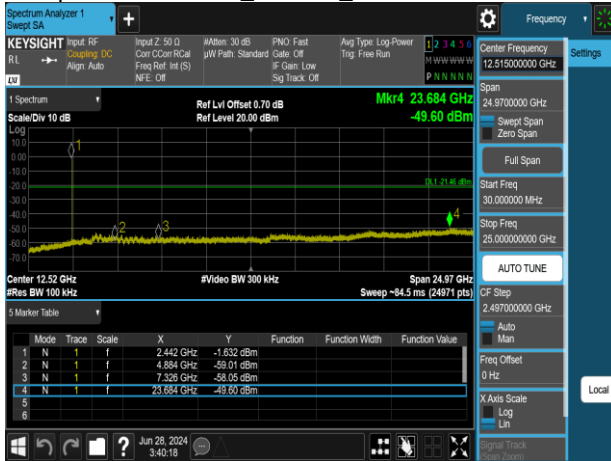

Spurious Emission_BLE 2M_MidCH20-2442MHz

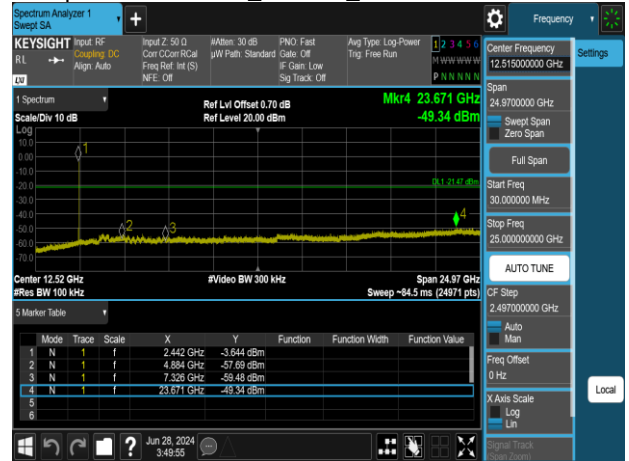

Spurious Emission_BLE 1M_HighCH39-2480MHz

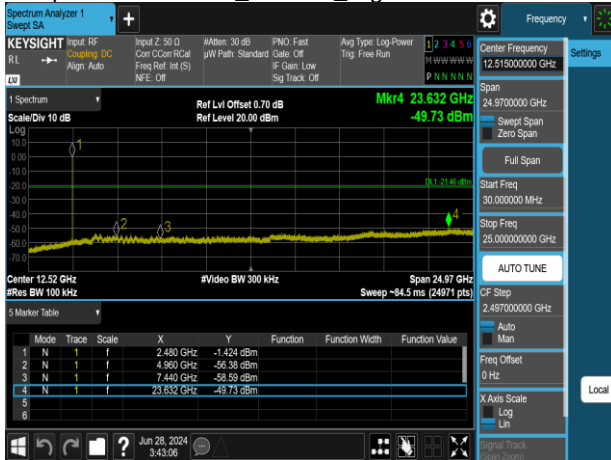

Spurious Emission_BLE 2M_HighCH39-2480MHz



4.6 RADIATION BANDEGE AND SPURIOUS EMISSION

4.6.1 Test Limit

FCC according to §15.247(d), §15.209 and §15.205,

In any 100 kHz bandwidth outside the authorized frequency band, all harmonic and spurious must be least 20 dB below the highest emission level with the authorized frequency band. Radiation emission which fall in the restricted bands must also follow the FCC section 15.209 as below limit in table.

Below 30 MHz

Frequency	Field Strength (microvolts/m)	Magnetic H-Field (microamperes/m)	Measurement Distance (metres)
9-490 kHz	2,400/F (F in kHz)	2,400/F (F in kHz)	300
490-1,705 kHz	24,000/F (F in kHz)	24,000/F (F in kHz)	30
1.705-30 MHz	30	N/A	30

Above 30 MHz

Frequency (MHz)	Field Strength microvolts/m at 3 metres (watts, e.i.r.p.)	
	Transmitters	Receivers
30-88	100 (3 nW)	100 (3 nW)
88-216	150 (6.8 nW)	150 (6.8 nW)
216-960	200 (12 nW)	200 (12 nW)
Above 960	500 (75 nW)	500 (75 nW)

Remark:

Although these tests were performed other than open area test site, adequate comparison measurements were confirmed against 30 m open are test site. Therefore sufficient tests were made to demonstrate that the alternative site produces results that correlate with the ones of tests made in an open field based on KDB 414788.

4.6.2 Test Procedure

1. The EUT is placed on a turntable, Above 1 GHz is 1.5m and below 1 GHz is 0.8m above ground plane. The EUT Configured un accordance with ANSI C63.10: 2013, and the EUT set in a continuous mode.
2. The turntable shall be rotated for 360 degrees to determine the position of maximum emission level. And EUT is set 3m away from the receiving antenna, which is scanned from 1m to 4m above the ground plane to find out the highest emissions. Measurement are made polarized in both the vertical and the horizontal positions with antenna.
3. Span shall wide enough to full capture the emission measured. The SA from 9KHz to 26.5GHz set to the low, Mid and High channels with the EUT transmit.
4. No emission found between lowest internal used/generated frequency to 30MHz (9KHz~30MHz).

Radiated emission below 30MHz is measured in a 9m*6m*6m semi-ane choic chamber, the measurements correspond to those obtained at an open-field test site. There is a comparison data of both open-field test site and semi-Anechoic chamber, and the result came out very similar.

5. The SA setting following :

(1) Below 30MHz :

(1.1) 9KHz-490KHz : RBW=200Hz / VBW=1kHz / Sweep=AUTO

(1.2) 490KHz-30MHz : RBW=10kHz / VBW=30kHz / Sweep=AUTO

(2) 30MHz to 1GHz : RBW = 100kHz, VBW \geq 3*RBW, Sweep = Auto,

Detector = Peak, Trace = Max hold.

(3) Above 1GHz :

(3.1) For Peak measurement : RBW = 1MHz, VBW \geq 3 RBW, Sweep = Auto,
Detector = Peak, Trace = Max hold.

(3.2) For Average measurement : RBW = 1MHz, VBW

·If Duty Cycle \geq 98%, VBW=10Hz.

·If Duty Cycle < 98%, VBW=1/T.

6. Data result :

Actual FS=Spectrum Reading Level + Factor

Margin=Actual FS- Limit

4.6.3 Test Setup

9kHz ~ 30MHz

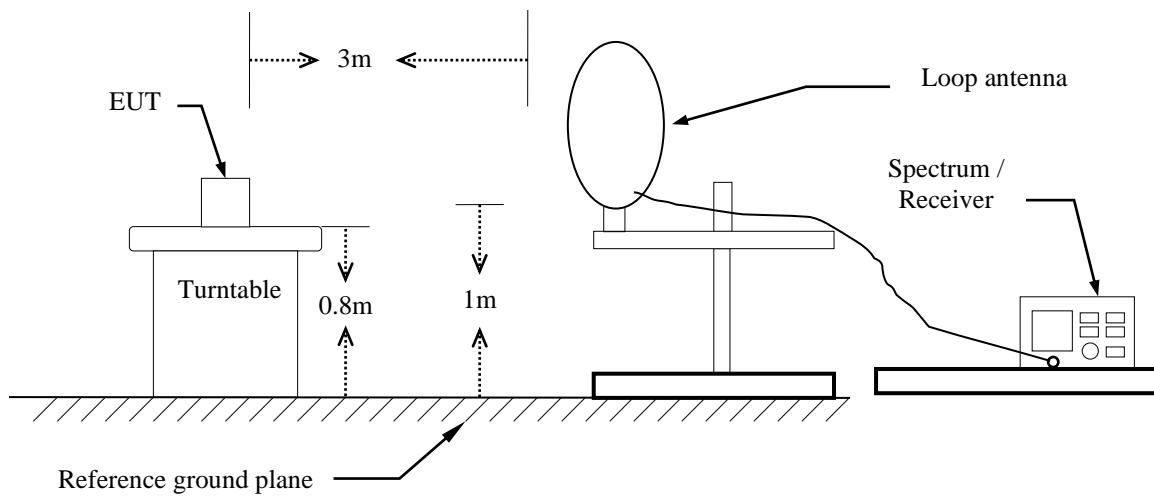

30MHz ~ 1GHz

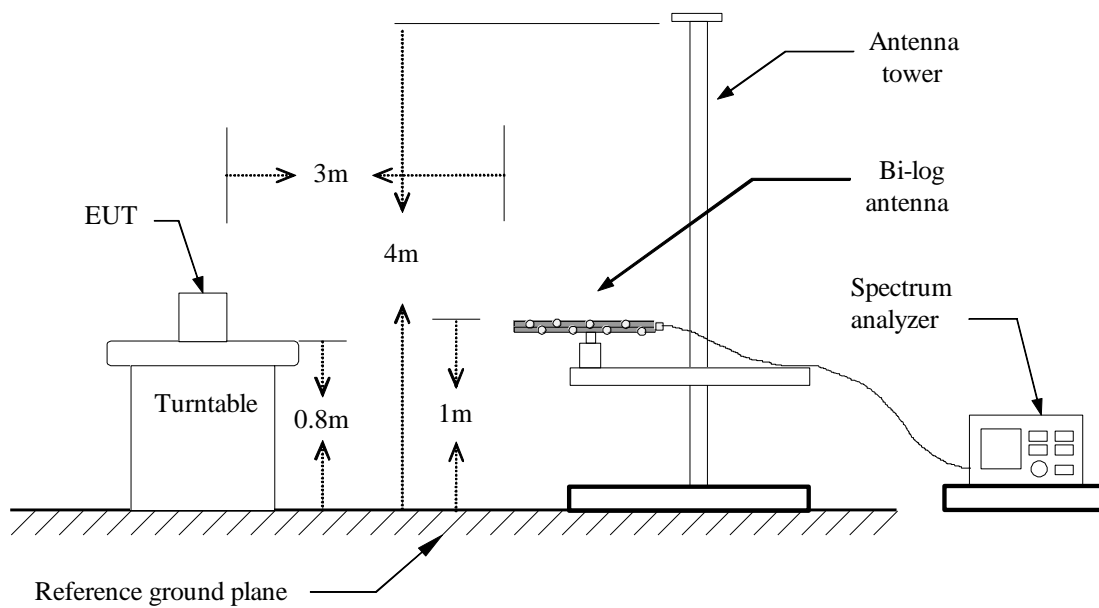

Above 1 GHz

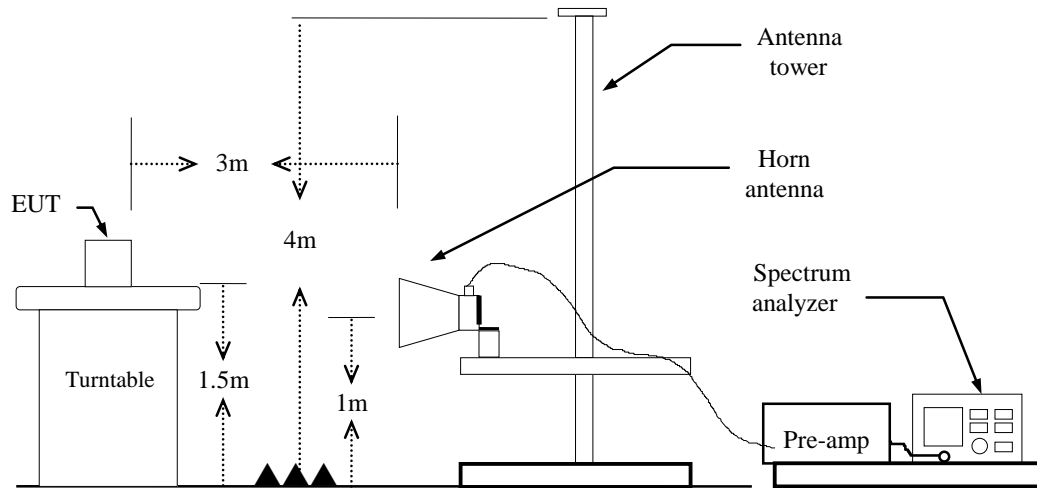

4.6.4 Test Result

Band Edge Test Data

Project No	:TM-2402000257P	Test Date	:2024-06-27
Operation Band	:BLE_1M	Temp./Humi.	:24.6/57
Frequency	:2402 MHz	Antenna Pol.	:VERTICAL
Operation Mode	:Bandedge	Engineer	:Tony Chao
EUT Pol	:E1	Test Chamber	: 966A
Setting	:		

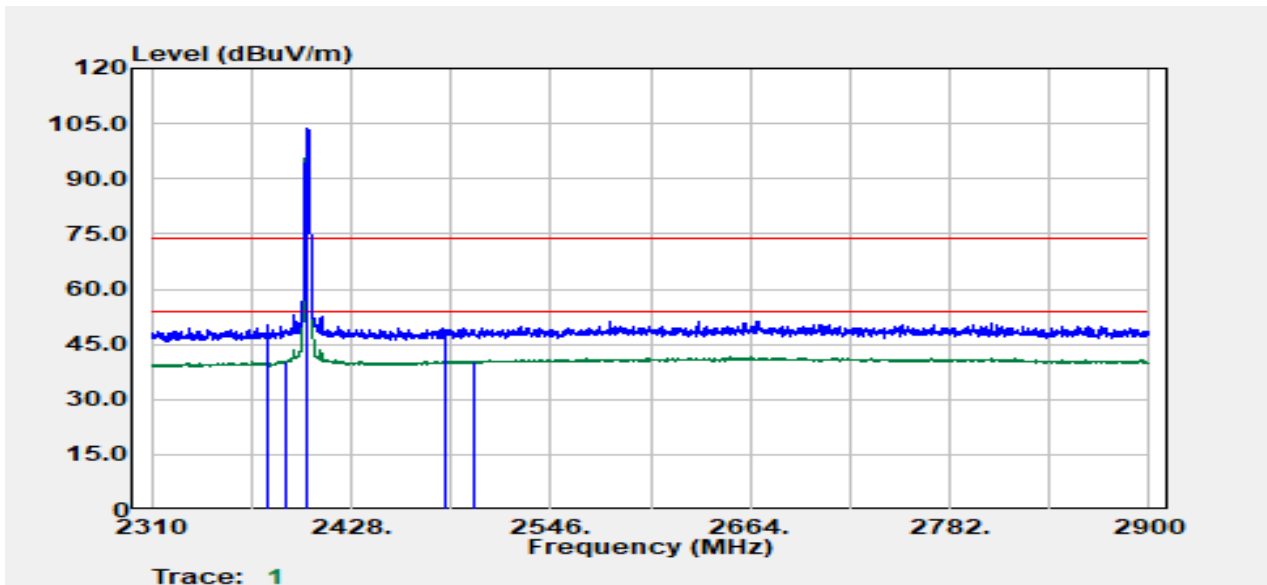

Freq. MHz	Detector Mode PK/QP/AV	Spectrum Read Level dB μ V	Factor dB	Actual FS dB μ V/m	Limit dB μ V/m	Margin dB
2379.03	Peak	44.08	6.08	50.16	74.00	-23.84
2389.53	Average	34.21	6.27	40.48	54.00	-13.52
2402.00	Peak	97.23	6.29	103.52	--	--
2402.00	Average	96.93	6.29	103.22	--	--
2483.50	Peak	42.87	6.71	49.58	74.00	-24.42
2500.08	Average	33.66	6.84	40.50	54.00	-13.50

Project No :TM-2402000257P
 Operation Band :BLE_1M
 Frequency :2402 MHz
 Operation Mode :Bandedge
 EUT Pol :E1
 Setting :

Test Date :2024-06-27
 Temp./Humi. :24.6/57
 Antenna Pol. :HORIZONTAL
 Engineer :Tony Chao
 Test Chamber : 966A

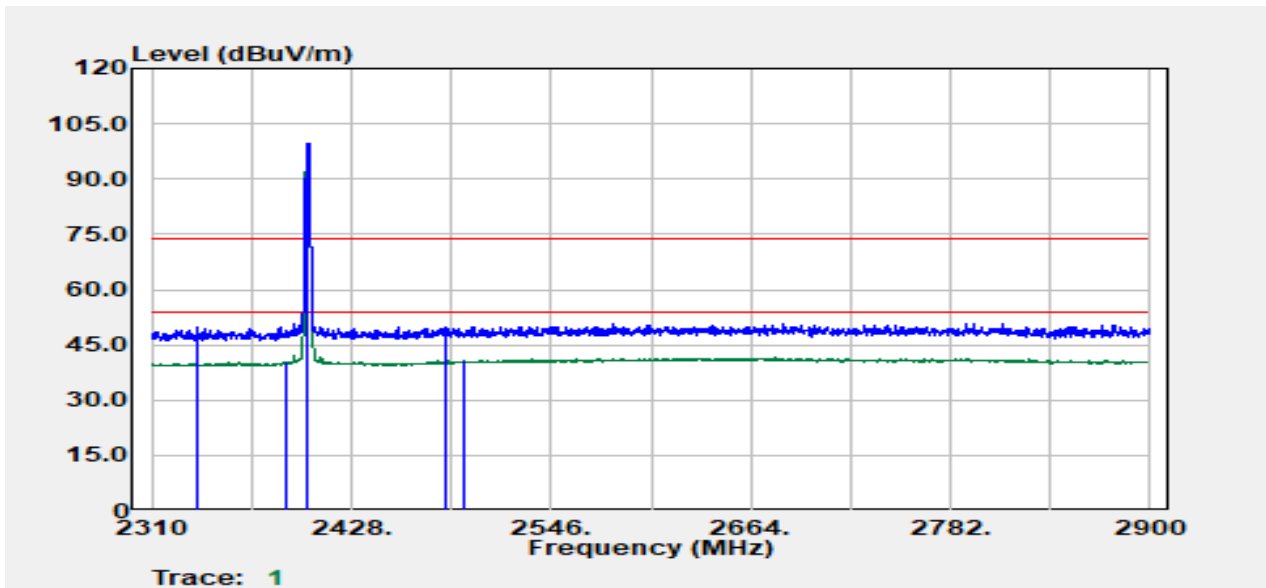

Freq. MHz	Detector Mode PK/QP/AV	Spectrum Read Level dB μ V	Factor dB	Actual FS dB μ V/m	Limit dB μ V/m	Margin dB
2337.01	Peak	43.77	6.13	49.90	74.00	-24.10
2388.78	Average	33.96	6.25	40.21	54.00	-13.79
2402.00	Peak	93.54	6.29	99.83	--	--
2402.00	Average	93.26	6.29	99.55	--	--
2483.50	Peak	43.03	6.71	49.75	74.00	-24.25
2495.08	Average	33.74	6.82	40.57	54.00	-13.43

Project No	:TM-2402000257P	Test Date	:2024-06-27
Operation Band	:BLE_1M	Temp./Humi.	:24.6/57
Frequency	:2480 MHz	Antenna Pol.	:VERTICAL
Operation Mode	:Bandedge	Engineer	:Tony Chao
EUT Pol	:E1	Test Chamber	: 966A
Setting	:		

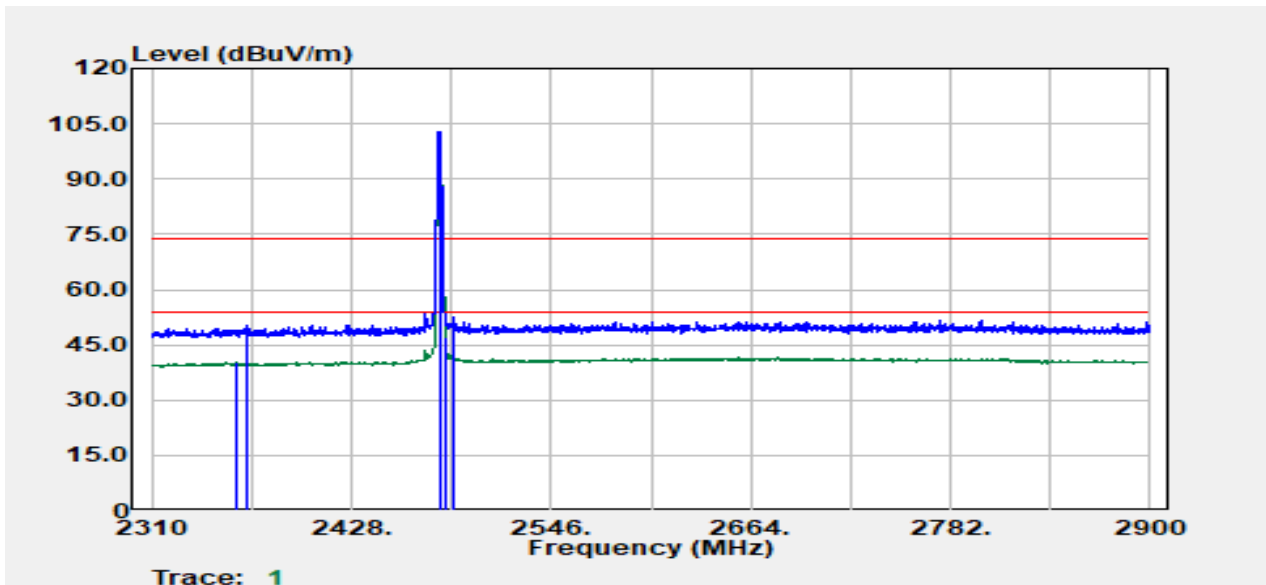

Freq. MHz	Detector Mode PK/QP/AV	Spectrum Read Level dB μ V	Factor dB	Actual FS dB μ V/m	Limit dB μ V/m	Margin dB
2360.02	Average	33.98	6.25	40.23	54.00	-13.77
2366.02	Peak	43.89	6.20	50.08	74.00	-23.92
2480.00	Peak	96.05	6.67	102.71	--	--
2480.00	Average	95.83	6.67	102.49	--	--
2483.57	Average	40.41	6.72	47.12	54.00	-6.88
2488.08	Peak	45.84	6.78	52.62	74.00	-21.38

Project No :TM-2402000257P
 Operation Band :BLE_1M
 Frequency :2480 MHz
 Operation Mode :Bandedge
 EUT Pol :E1
 Setting :

Test Date :2024-06-27
 Temp./Humi. :24.6/57
 Antenna Pol. :HORIZONTAL
 Engineer :Tony Chao
 Test Chamber : 966A

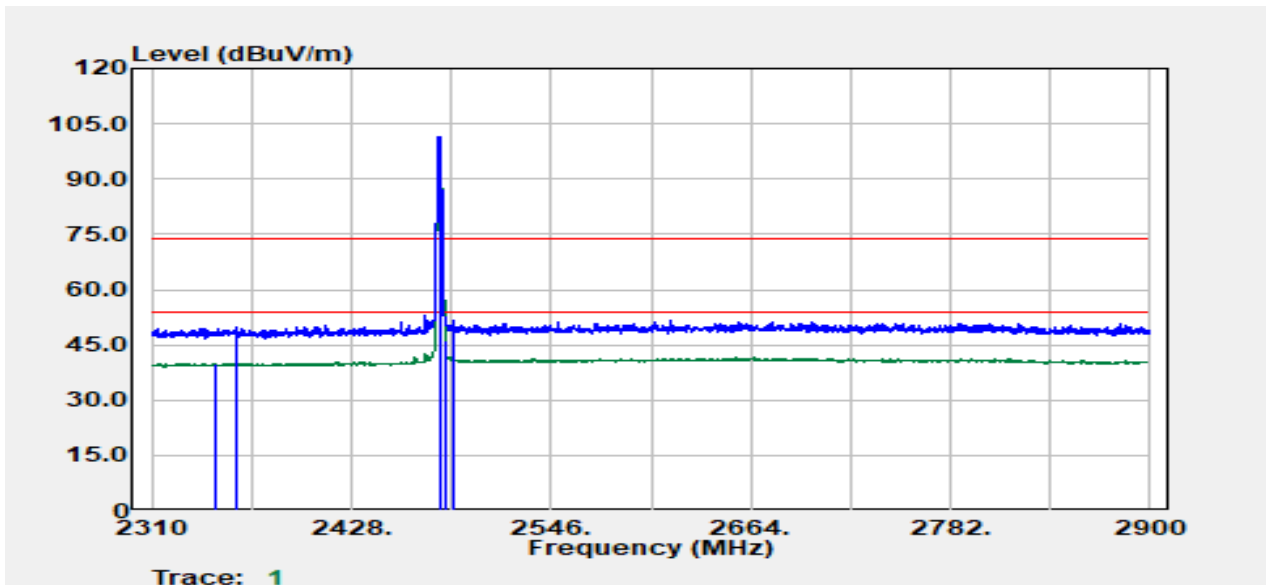

Freq. MHz	Detector Mode PK/QP/AV	Spectrum Read Level dB μ V	Factor dB	Actual FS dB μ V/m	Limit dB μ V/m	Margin dB
2348.02	Average	33.73	6.21	39.95	54.00	-14.05
2359.52	Peak	43.55	6.25	49.80	74.00	-24.20
2480.00	Peak	94.95	6.67	101.62	--	--
2480.00	Average	94.72	6.67	101.39	--	--
2483.57	Average	39.57	6.72	46.28	54.00	-7.72
2487.83	Peak	44.91	6.77	51.68	74.00	-22.32

Project No	:TM-2402000257P	Test Date	:2024-06-27
Operation Band	:BLE_2M	Temp./Humi.	:24.6/57
Frequency	:2402 MHz	Antenna Pol.	:VERTICAL
Operation Mode	:Bandedge	Engineer	:Tony Chao
EUT Pol	:E1	Test Chamber	: 966A
Setting	:		

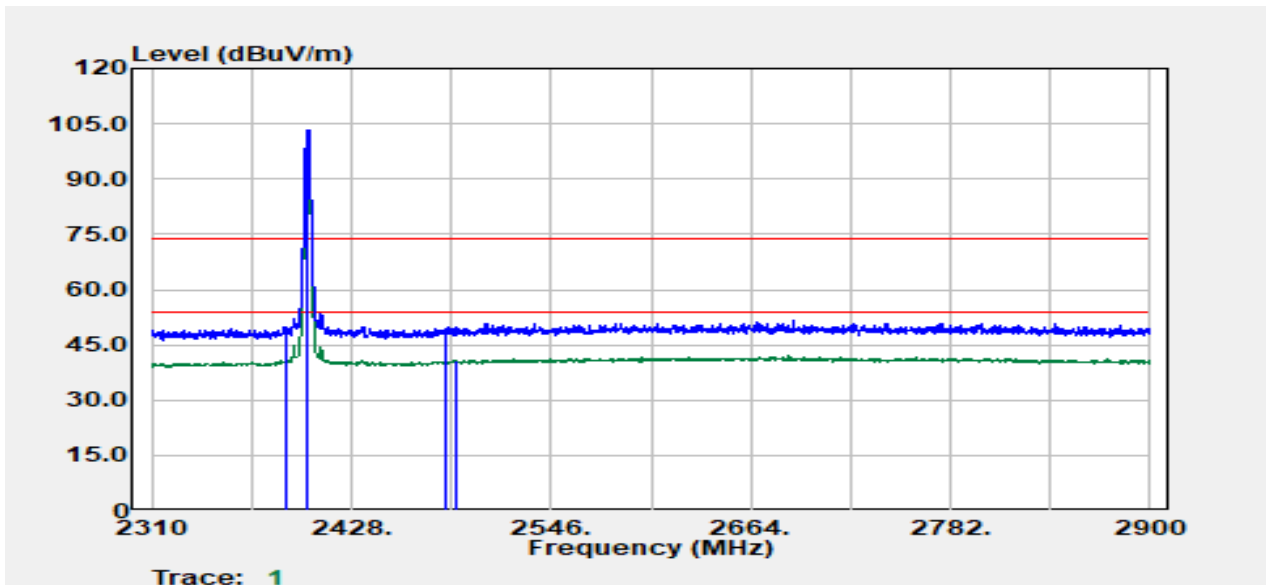

Freq. MHz	Detector Mode PK/QP/AV	Spectrum Read Level dBμV	Factor dB	Actual FS dBμV/m	Limit dBμV/m	Margin dB
2388.78	Average	34.68	6.25	40.93	54.00	-13.07
2389.03	Peak	43.65	6.26	49.91	74.00	-24.09
2402.00	Peak	96.95	6.29	103.24	--	--
2402.00	Average	95.79	6.29	102.08	--	--
2483.50	Peak	43.07	6.71	49.79	74.00	-24.21
2490.08	Average	33.95	6.80	40.75	54.00	-13.25

Project No :TM-2402000257P
 Operation Band :BLE_2M
 Frequency :2402 MHz
 Operation Mode :Bandedge
 EUT Pol :E1
 Setting :

Test Date :2024-06-27
 Temp./Humi. :24.6/57
 Antenna Pol. :HORIZONTAL
 Engineer :Tony Chao
 Test Chamber : 966A

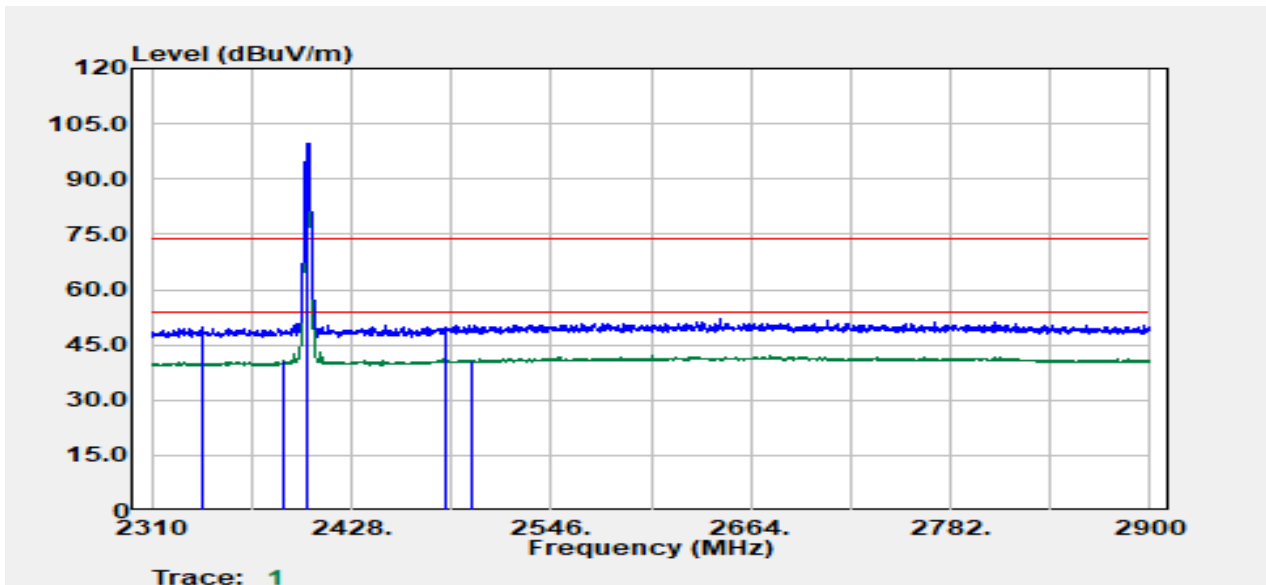

Freq. MHz	Detector Mode PK/QP/AV	Spectrum Read Level dB μ V	Factor dB	Actual FS dB μ V/m	Limit dB μ V/m	Margin dB
2339.76	Peak	43.81	6.11	49.92	74.00	-24.08
2388.28	Average	34.34	6.24	40.58	54.00	-13.42
2402.00	Peak	93.19	6.29	99.49	--	--
2402.00	Average	91.99	6.29	98.28	--	--
2483.50	Peak	43.72	6.71	50.43	74.00	-23.57
2499.58	Average	33.89	6.84	40.73	54.00	-13.27

Report No.: TMWK2406002111KR

Project No	:TM-2402000257P	Test Date	:2024-06-27
Operation Band	:BLE_2M	Temp./Humi.	:24.6/57
Frequency	:2480 MHz	Antenna Pol.	:VERTICAL
Operation Mode	:Bandedge	Engineer	:Tony Chao
EUT Pol	:E1	Test Chamber	: 966A
Setting	:		

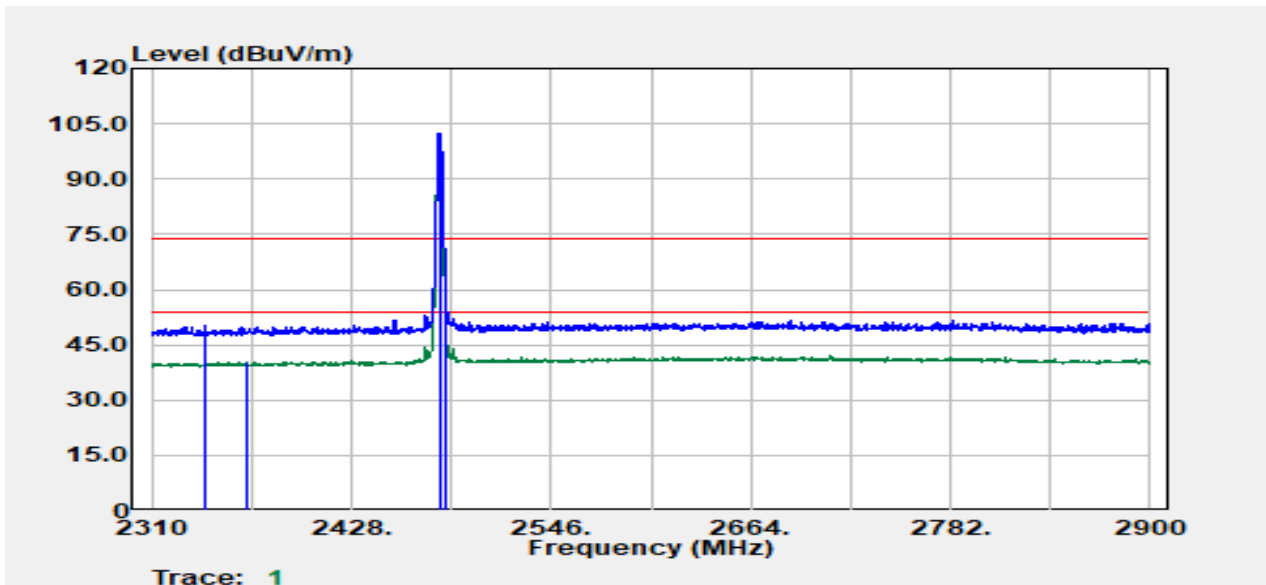

Freq. MHz	Detector Mode PK/QP/AV	Spectrum Read Level d μ V	Factor dB	Actual FS d μ V/m	Limit d μ V/m	Margin dB
2341.76	Peak	44.32	6.13	50.46	74.00	-23.54
2366.52	Average	34.15	6.19	40.34	54.00	-13.66
2480.00	Peak	95.86	6.67	102.52	--	--
2480.00	Average	94.66	6.67	101.33	--	--
2483.50	Peak	55.97	6.71	62.68	74.00	-11.32
2483.57	Average	45.69	6.72	52.40	54.00	-1.60

Project No :TM-2402000257P
 Operation Band :BLE_2M
 Frequency :2480 MHz
 Operation Mode :Bandedge
 EUT Pol :E1
 Setting :

Test Date :2024-06-27
 Temp./Humi. :24.6/57
 Antenna Pol. :HORIZONTAL
 Engineer :Tony Chao
 Test Chamber : 966A

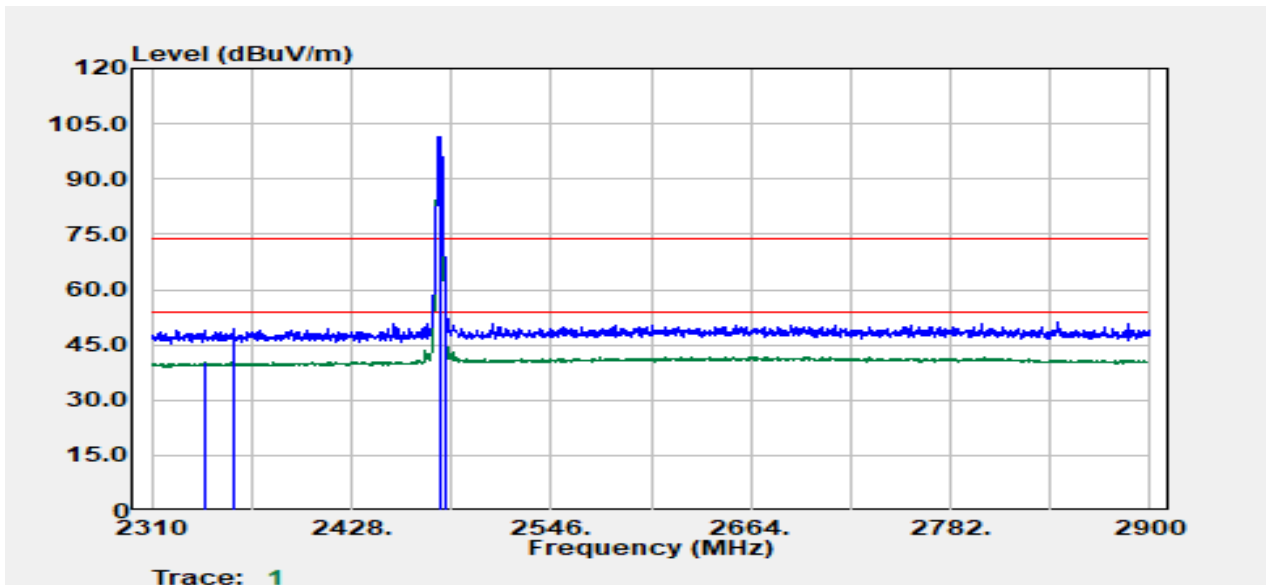

Freq. MHz	Detector Mode PK/QP/AV	Spectrum Read Level d μ V	Factor dB	Actual FS d μ V/m	Limit d μ V/m	Margin dB
2341.26	Average	34.33	6.13	40.46	54.00	-13.54
2358.27	Peak	43.21	6.25	49.46	74.00	-24.54
2480.00	Peak	94.73	6.67	101.40	--	--
2480.00	Average	93.62	6.67	100.28	--	--
2483.50	Peak	53.76	6.71	60.47	74.00	-13.53
2483.57	Average	44.99	6.72	51.71	54.00	-2.29

TX Test Data

Project No	:TM-2402000257P	Test Date	:2024-06-27
Operation Band	:BLE_2M	Temp./Humi.	:24.6/57
Frequency	:2402 MHz	Antenna Pol.	:VERTICAL
Operation Mode	:TX	Engineer	:Ray Li
EUT Pol	:E1	Test Chamber	: 966A
Setting	:		

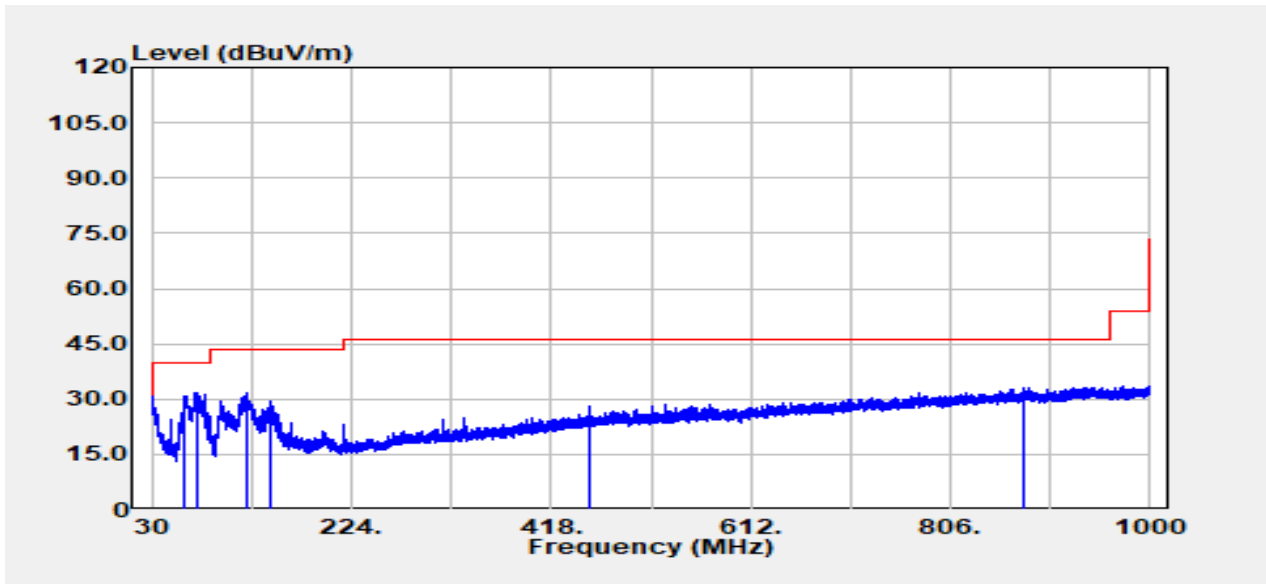

Freq. MHz	Detector Mode PK/QP/AV	Spectrum Read Level dB μ V	Factor dB	Actual FS dB μ V/m	Limit dB μ V/m	Margin dB
62.50	Peak	46.54	-15.58	30.96	40.00	-9.04
73.00	Peak	47.09	-15.35	31.74	40.00	-8.26
121.80	Peak	40.87	-8.99	31.88	43.50	-11.62
146.40	Peak	39.70	-10.11	29.59	43.50	-13.91
456.10	Peak	32.19	-4.21	27.98	46.00	-18.02
876.60	Peak	30.61	2.55	33.17	46.00	-12.83

Project No :TM-2402000257P
 Operation Band :BLE_2M
 Frequency :2402 MHz
 Operation Mode :TX
 EUT Pol :E1
 Setting :

Test Date :2024-06-27
 Temp./Humi. :24.6/57
 Antenna Pol. :HORIZONTAL
 Engineer :Ray Li
 Test Chamber : 966A

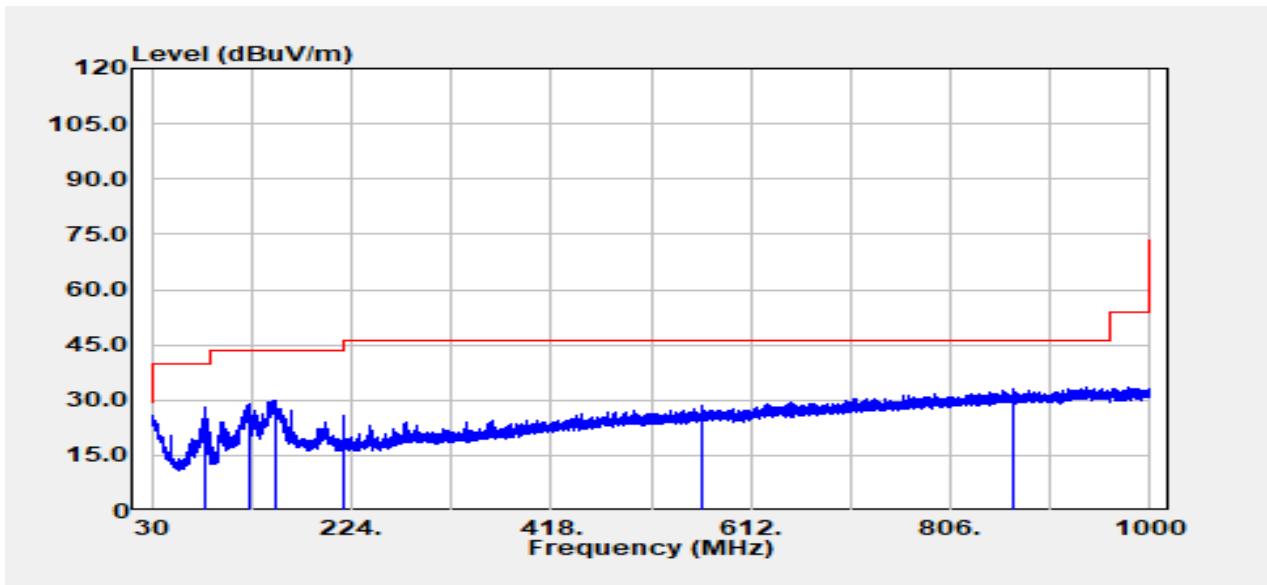

Freq. MHz	Detector Mode PK/QP/AV	Spectrum Read Level dBμV	Factor dB	Actual FS dBμV/m	Limit dBμV/m	Margin dB
81.90	Peak	43.59	-15.47	28.12	40.00	-11.88
123.70	Peak	37.97	-9.14	28.83	43.50	-14.67
150.00	Peak	40.14	-10.18	29.96	43.50	-13.54
216.00	Peak	37.79	-11.79	26.01	43.50	-17.49
564.00	Peak	30.71	-2.26	28.45	46.00	-17.55
866.40	Peak	30.31	2.59	32.90	46.00	-13.10

Project No	:TM-2402000257P	Test Date	:2024-06-27
Operation Band	:BLE_1M	Temp./Humi.	:24.6/57
Frequency	:2402 MHz	Antenna Pol.	:Vertical
Operation Mode	:TX	Engineer	:Tony Chao
EUT Pol	:E1	Test Chamber	: 966A
Setting	:		

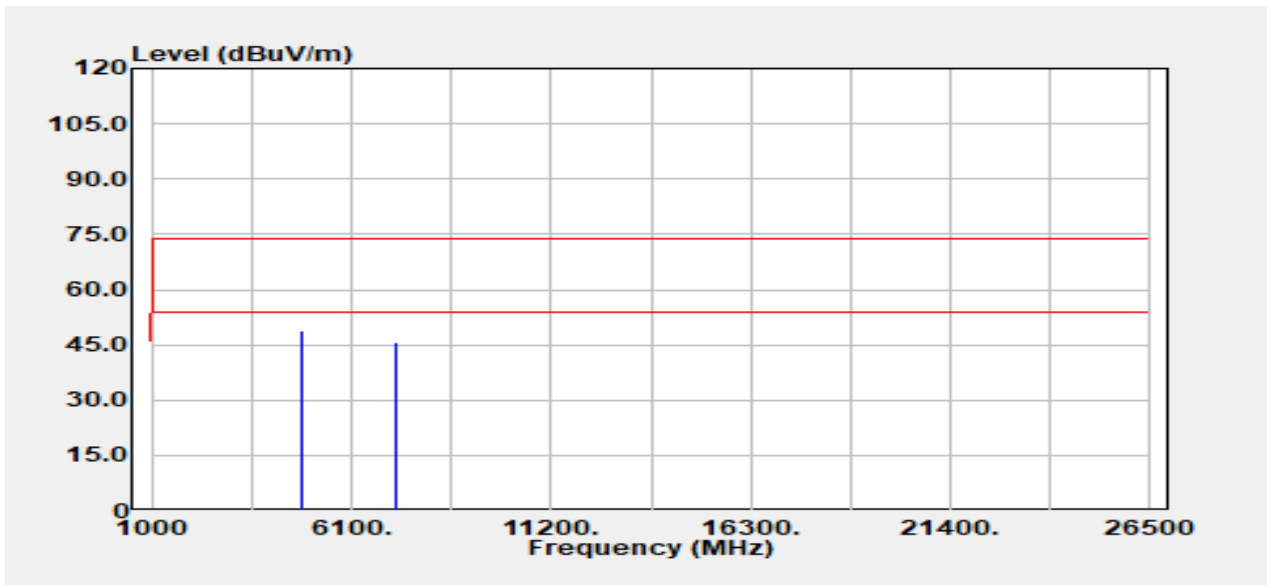

Freq. MHz	Detector Mode PK/QP/AV	Spectrum Read Level dB μ V	Factor dB	Actual FS dB μ V/m	Limit dB μ V/m	Margin dB
4804.00	Peak	46.74	2.23	48.97	74.00	-25.03
4804.00	Average	44.76	2.23	46.99	54.00	-7.01
7206.00	Peak	36.64	9.01	45.65	74.00	-28.35
7206.00	Average	33.01	9.01	42.02	54.00	-11.98

Project No	:TM-2402000257P	Test Date	:2024-06-27
Operation Band	:BLE_1M	Temp./Humi.	:24.6/57
Frequency	:2402 MHz	Antenna Pol.	:Horizontal
Operation Mode	:TX	Engineer	:Tony Chao
EUT Pol	:E1	Test Chamber	: 966A
Setting	:		

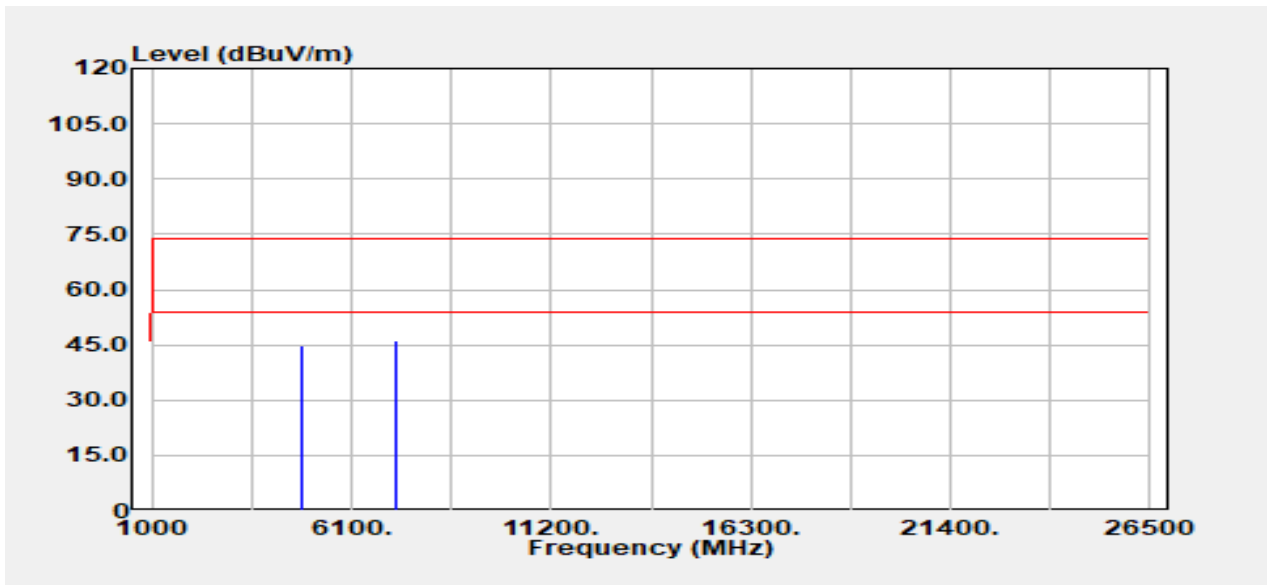

Freq. MHz	Detector Mode PK/QP/AV	Spectrum Read Level dB μ V	Factor dB	Actual FS dB μ V/m	Limit dB μ V/m	Margin dB
4804.00	Peak	42.72	2.23	44.95	74.00	-29.05
4804.00	Average	38.93	2.23	41.15	54.00	-12.85
7206.00	Peak	37.21	9.01	46.22	74.00	-27.78
7206.00	Average	34.04	9.01	43.05	54.00	-10.95

Project No	:TM-2402000257P	Test Date	:2024-06-27
Operation Band	:BLE_1M	Temp./Humi.	:24.6/57
Frequency	:2442 MHz	Antenna Pol.	:Vertical
Operation Mode	:TX	Engineer	:Tony Chao
EUT Pol	:E1	Test Chamber	: 966A
Setting	:		

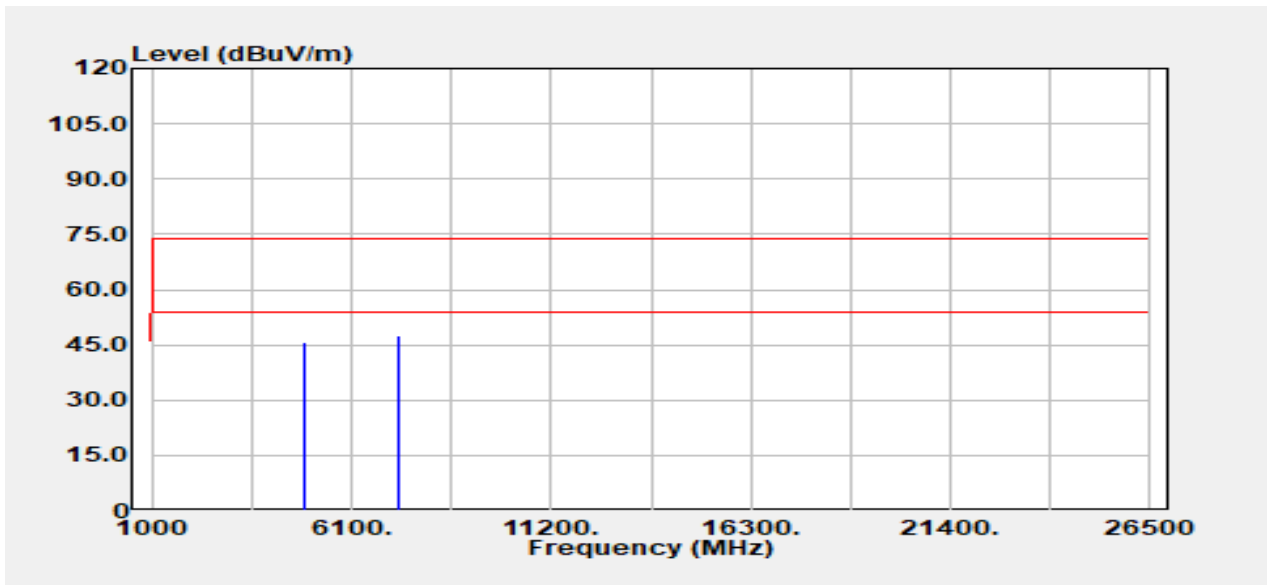

Freq. MHz	Detector Mode PK/QP/AV	Spectrum Read Level dB μ V	Factor dB	Actual FS dB μ V/m	Limit dB μ V/m	Margin dB
4884.00	Peak	43.32	2.58	45.90	74.00	-28.10
4884.00	Average	40.04	2.58	42.62	54.00	-11.38
7326.00	Peak	38.46	8.95	47.41	74.00	-26.59
7326.00	Average	34.23	8.95	43.19	54.00	-10.81

Project No	:TM-2402000257P	Test Date	:2024-06-27
Operation Band	:BLE_1M	Temp./Humi.	:24.6/57
Frequency	:2442 MHz	Antenna Pol.	:Horizontal
Operation Mode	:TX	Engineer	:Tony Chao
EUT Pol	:E1	Test Chamber	: 966A
Setting	:		

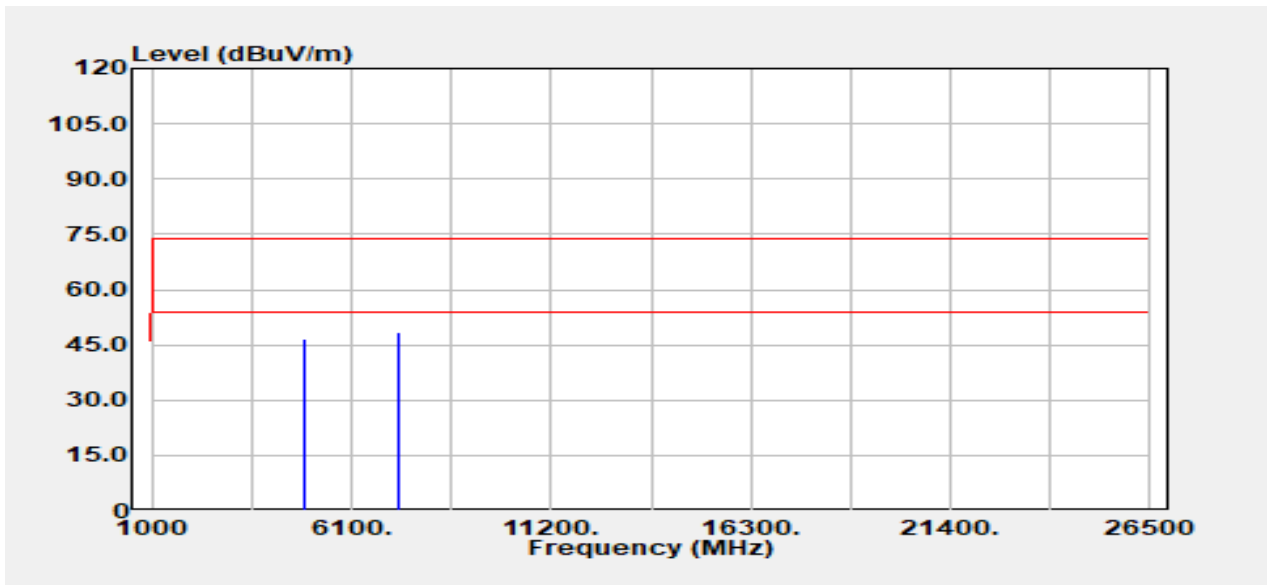

Freq. MHz	Detector Mode PK/QP/AV	Spectrum Read Level dB μ V	Factor dB	Actual FS dB μ V/m	Limit dB μ V/m	Margin dB
4884.00	Peak	44.23	2.58	46.81	74.00	-27.19
4884.00	Average	41.77	2.58	44.35	54.00	-9.65
7326.00	Peak	39.59	8.95	48.54	74.00	-25.46
7326.00	Average	34.88	8.95	43.83	54.00	-10.17

Project No	:TM-2402000257P	Test Date	:2024-06-27
Operation Band	:BLE_1M	Temp./Humi.	:24.6/57
Frequency	:2480 MHz	Antenna Pol.	:Vertical
Operation Mode	:TX	Engineer	:Tony Chao
EUT Pol	:E1	Test Chamber	: 966A
Setting	:		

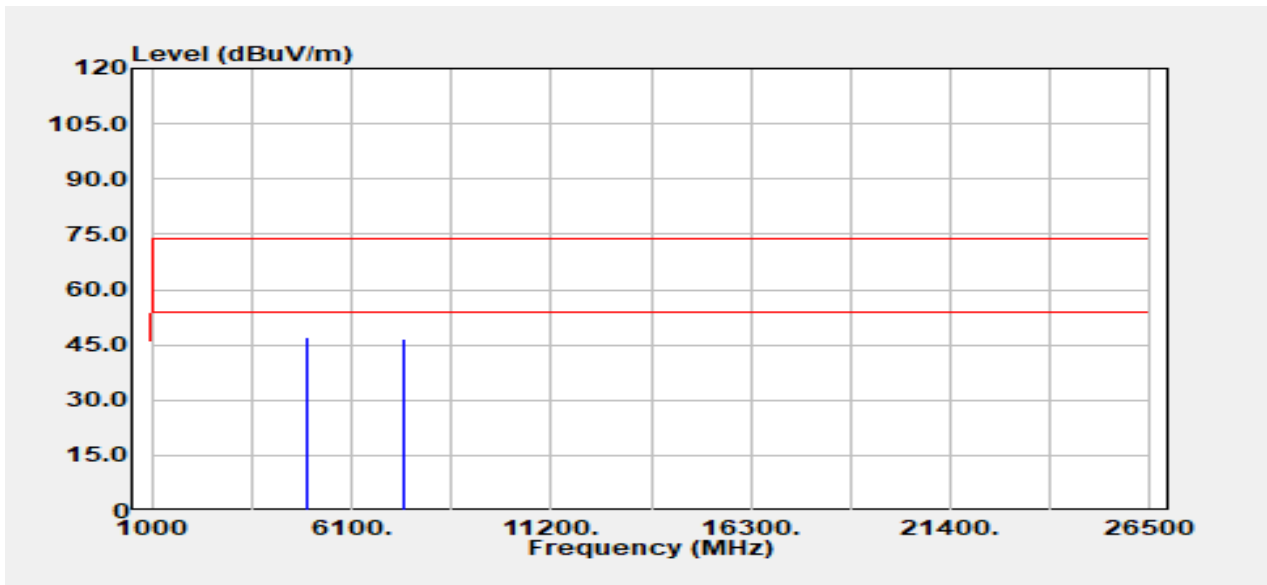

Freq. MHz	Detector Mode PK/QP/AV	Spectrum Read Level dB μ V	Factor dB	Actual FS dB μ V/m	Limit dB μ V/m	Margin dB
4960.00	Peak	43.68	3.21	46.89	74.00	-27.11
4960.00	Average	41.42	3.21	44.63	54.00	-9.37
7440.00	Peak	37.81	8.92	46.73	74.00	-27.27
7440.00	Average	33.81	8.92	42.73	54.00	-11.27

Project No	:TM-2402000257P	Test Date	:2024-06-27
Operation Band	:BLE_1M	Temp./Humi.	:24.6/57
Frequency	:2480 MHz	Antenna Pol.	:Horizontal
Operation Mode	:TX	Engineer	:Tony Chao
EUT Pol	:E1	Test Chamber	: 966A
Setting	:		

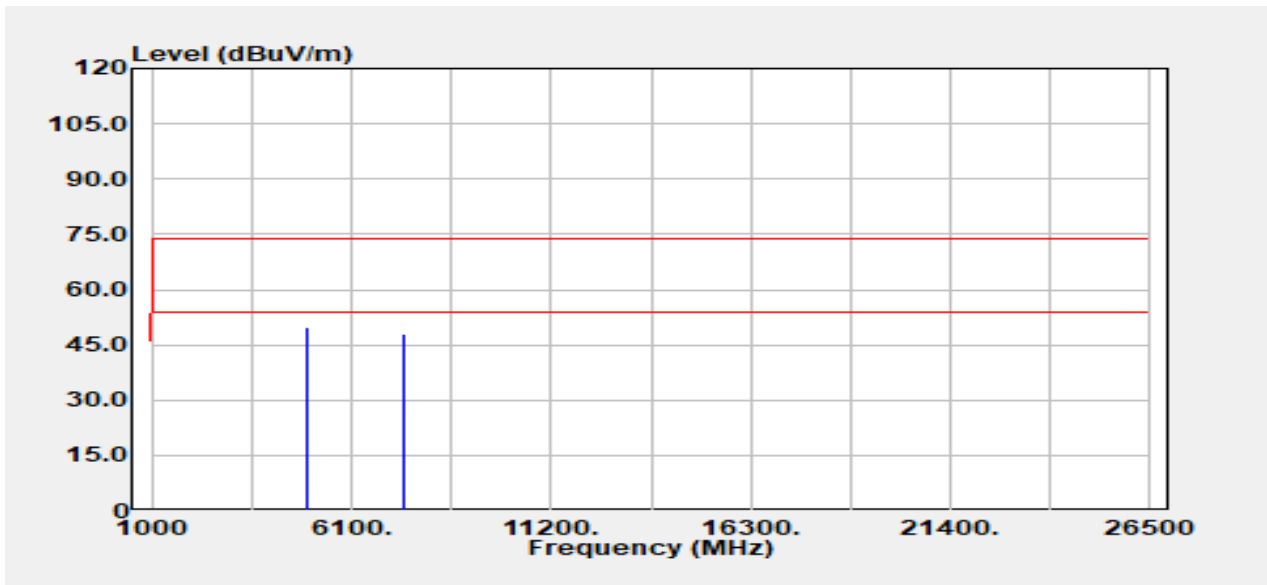

Freq. MHz	Detector Mode PK/QP/AV	Spectrum Read Level dB μ V	Factor dB	Actual FS dB μ V/m	Limit dB μ V/m	Margin dB
4960.00	Peak	46.47	3.21	49.69	74.00	-24.31
4960.00	Average	43.38	3.21	46.59	54.00	-7.41
7440.00	Peak	38.90	8.92	47.82	74.00	-26.18
7440.00	Average	35.94	8.92	44.86	54.00	-9.14

Project No	:TM-2402000257P	Test Date	:2024-06-27
Operation Band	:BLE_2M	Temp./Humi.	:24.6/57
Frequency	:2402 MHz	Antenna Pol.	:Vertical
Operation Mode	:TX	Engineer	:Ray Li
EUT Pol	:E1	Test Chamber	: 966A
Setting	:		

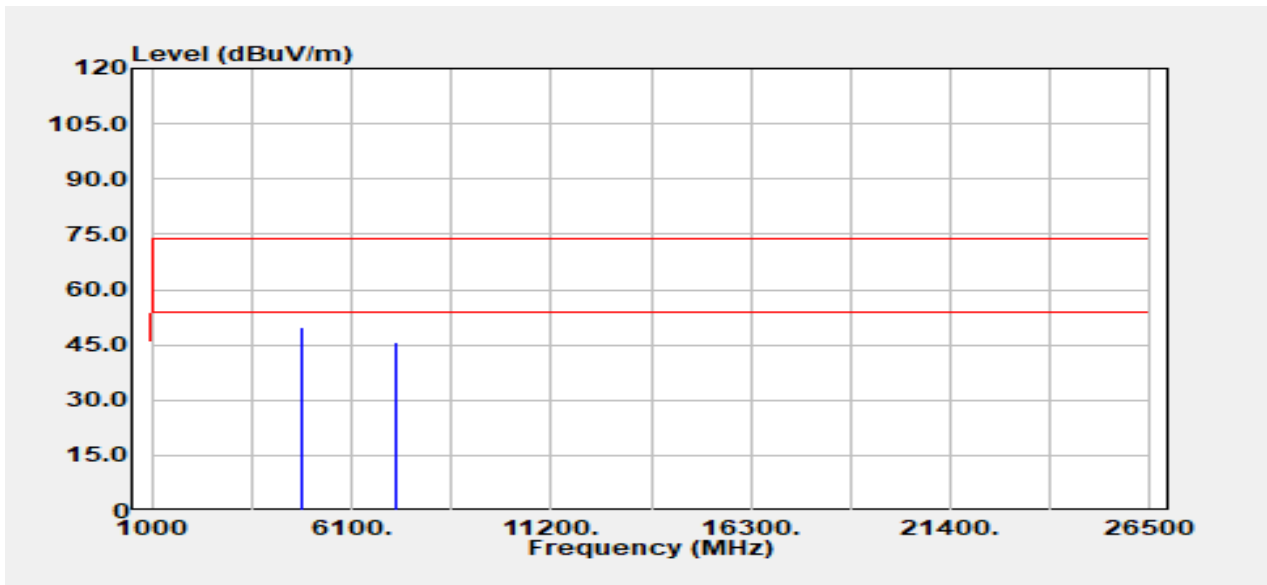

Freq. MHz	Detector Mode PK/QP/AV	Spectrum Read Level dB μ V	Factor dB	Actual FS dB μ V/m	Limit dB μ V/m	Margin dB
4804.00	Peak	47.56	2.23	49.78	74.00	-24.22
4804.00	Average	43.18	2.23	45.41	54.00	-8.59
7206.00	Peak	36.68	9.01	45.69	74.00	-28.31
7206.00	Average	31.55	9.01	40.56	54.00	-13.44

Project No	:TM-2402000257P	Test Date	:2024-06-27
Operation Band	:BLE_2M	Temp./Humi.	:24.6/57
Frequency	:2402 MHz	Antenna Pol.	:Horizontal
Operation Mode	:TX	Engineer	:Ray Li
EUT Pol	:E1	Test Chamber	: 966A
Setting	:		

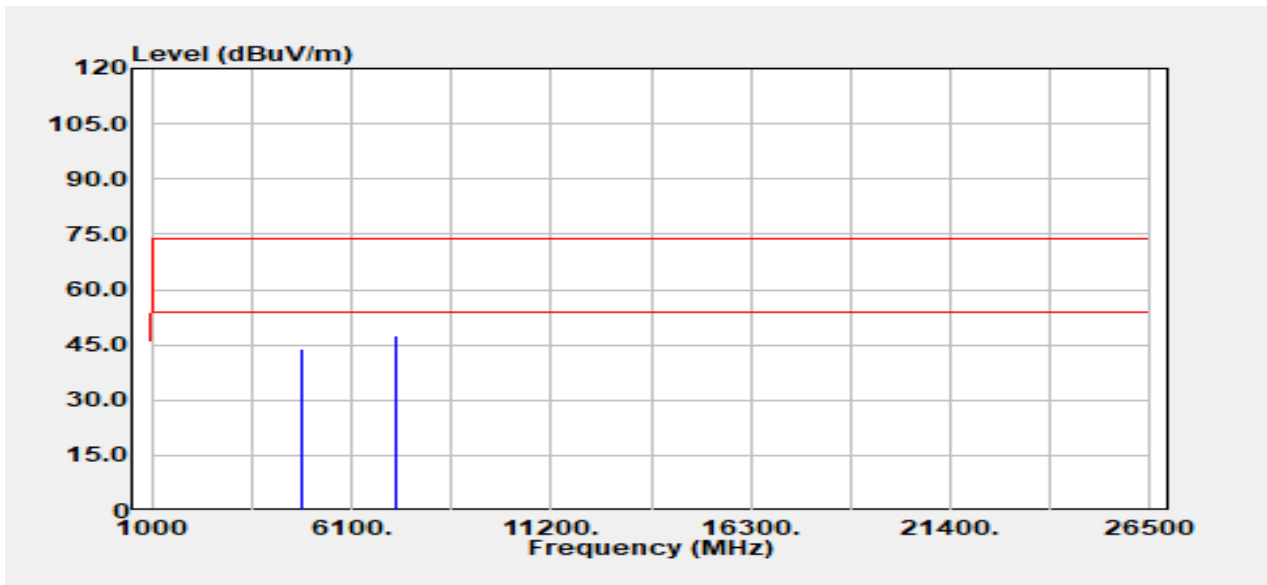

Freq. MHz	Detector Mode PK/QP/AV	Spectrum Read Level dB μ V	Factor dB	Actual FS dB μ V/m	Limit dB μ V/m	Margin dB
4804.00	Peak	41.75	2.23	43.98	74.00	-30.02
4804.00	Average	37.17	2.23	39.40	54.00	-14.60
7206.00	Peak	38.34	9.01	47.35	74.00	-26.65
7206.00	Average	32.39	9.01	41.41	54.00	-12.59

Project No	:TM-2402000257P	Test Date	:2024-06-27
Operation Band	:BLE_2M	Temp./Humi.	:24.6/57
Frequency	:2442 MHz	Antenna Pol.	:Vertical
Operation Mode	:TX	Engineer	:Ray Li
EUT Pol	:E1	Test Chamber	: 966A
Setting	:		

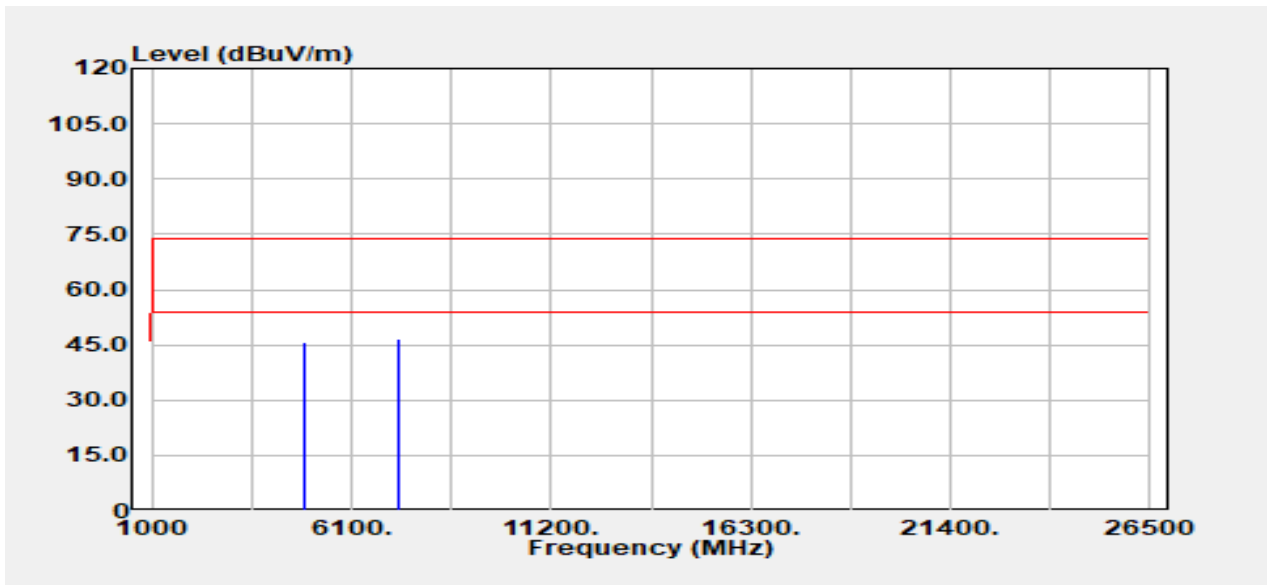

Freq. MHz	Detector Mode PK/QP/AV	Spectrum Read Level dB μ V	Factor dB	Actual FS dB μ V/m	Limit dB μ V/m	Margin dB
4884.00	Peak	42.99	2.58	45.57	74.00	-28.43
4884.00	Average	37.85	2.58	40.43	54.00	-13.57
7326.00	Peak	37.85	8.95	46.80	74.00	-27.20
7326.00	Average	33.09	8.95	42.05	54.00	-11.95

Project No	:TM-2402000257P	Test Date	:2024-06-27
Operation Band	:BLE_2M	Temp./Humi.	:24.6/57
Frequency	:2442 MHz	Antenna Pol.	:Horizontal
Operation Mode	:TX	Engineer	:Ray Li
EUT Pol	:E1	Test Chamber	: 966A
Setting	:		

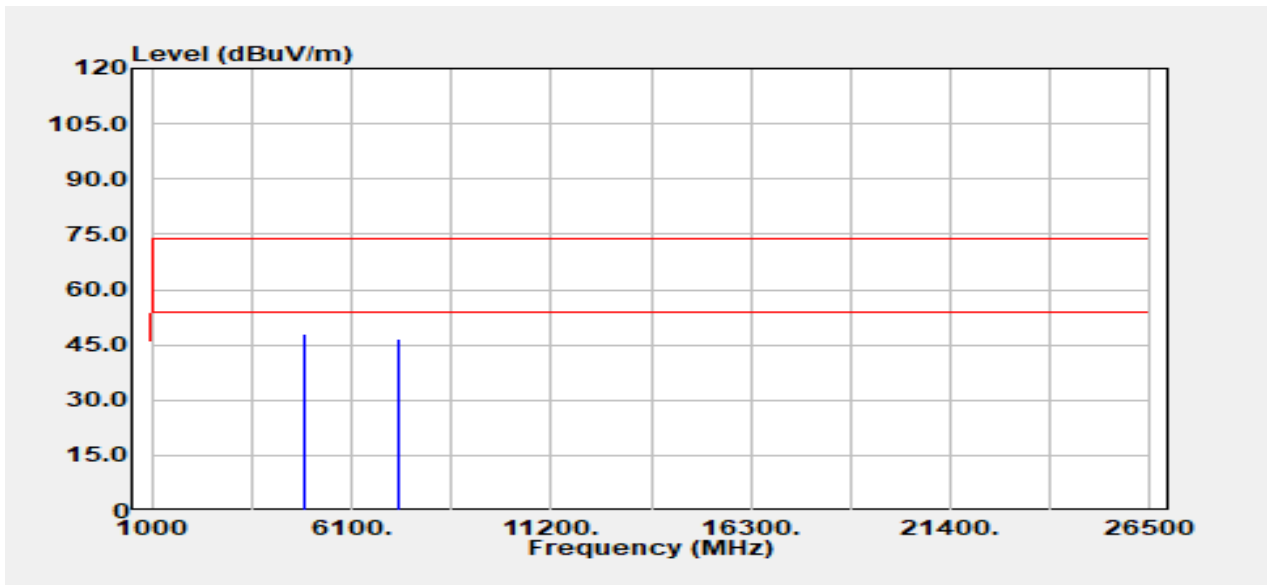

Freq. MHz	Detector Mode PK/QP/AV	Spectrum Read Level dB μ V	Factor dB	Actual FS dB μ V/m	Limit dB μ V/m	Margin dB
4884.00	Peak	45.57	2.58	48.15	74.00	-25.85
4884.00	Average	40.58	2.58	43.16	54.00	-10.84
7326.00	Peak	37.52	8.95	46.48	74.00	-27.52
7326.00	Average	34.18	8.95	43.14	54.00	-10.86

Project No	:TM-2402000257P	Test Date	:2024-06-27
Operation Band	:BLE_2M	Temp./Humi.	:24.6/57
Frequency	:2480 MHz	Antenna Pol.	:Vertical
Operation Mode	:TX	Engineer	:Ray Li
EUT Pol	:E1	Test Chamber	: 966A
Setting	:		

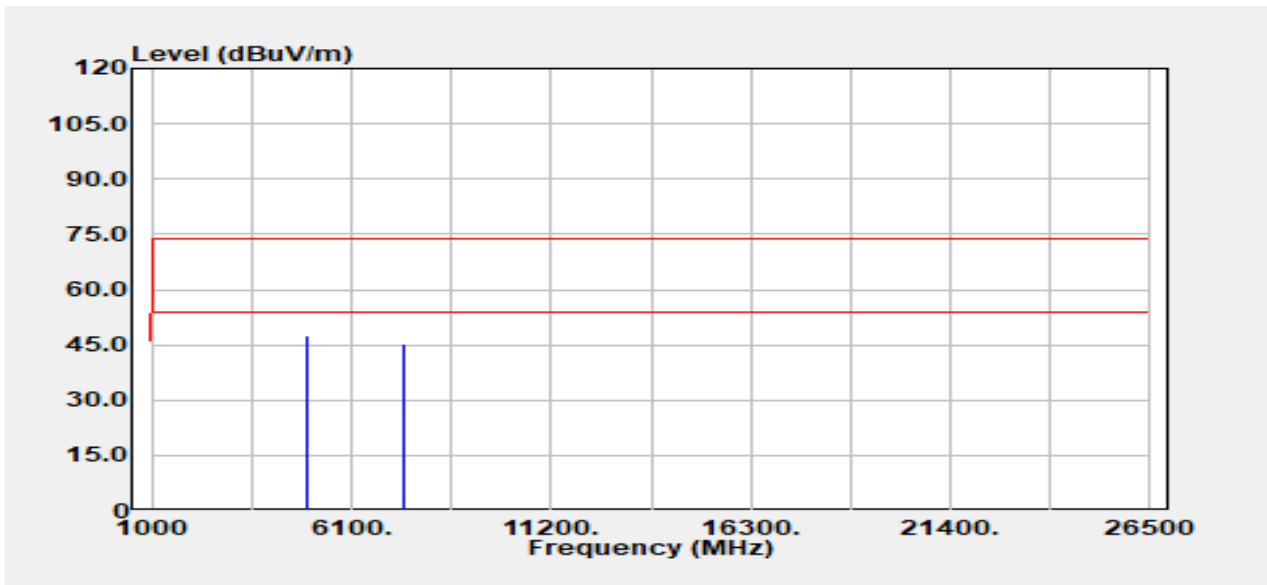

Freq. MHz	Detector Mode PK/QP/AV	Spectrum Read Level dB μ V	Factor dB	Actual FS dB μ V/m	Limit dB μ V/m	Margin dB
4960.00	Peak	44.11	3.21	47.32	74.00	-26.68
4960.00	Average	39.68	3.21	42.90	54.00	-11.10
7440.00	Peak	36.51	8.92	45.43	74.00	-28.57
7440.00	Average	32.50	8.92	41.42	54.00	-12.58

Project No	:TM-2402000257P	Test Date	:2024-06-27
Operation Band	:BLE_2M	Temp./Humi.	:24.6/57
Frequency	:2480 MHz	Antenna Pol.	:Horizontal
Operation Mode	:TX	Engineer	:Ray Li
EUT Pol	:E1	Test Chamber	: 966A
Setting	:		

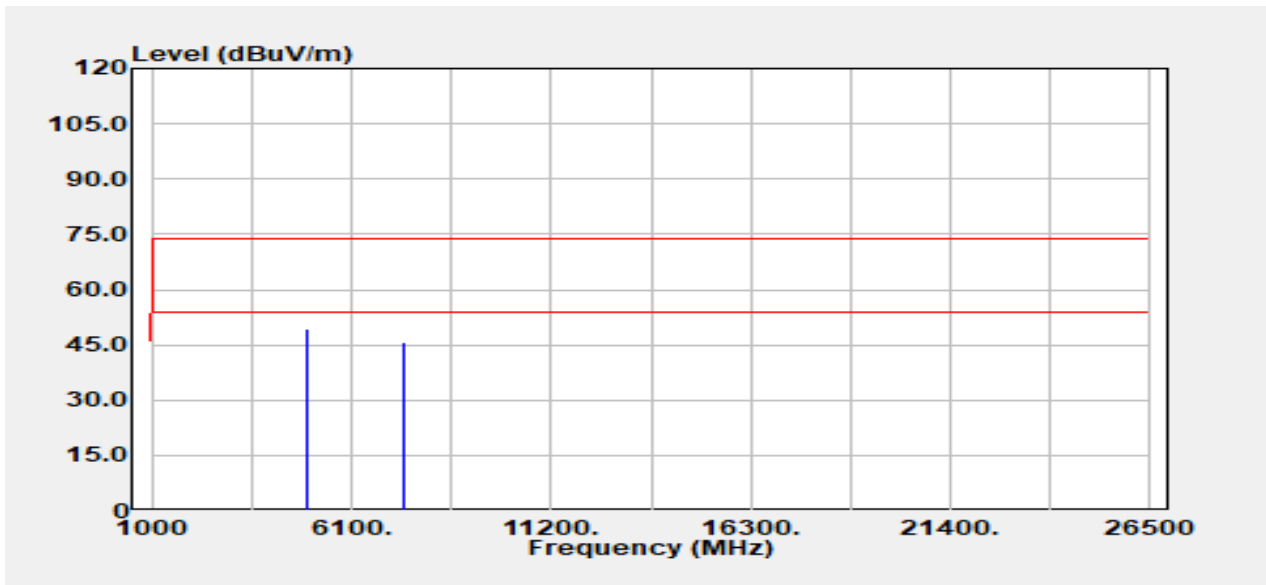

Freq. MHz	Detector Mode PK/QP/AV	Spectrum Read Level dB μ V	Factor dB	Actual FS dB μ V/m	Limit dB μ V/m	Margin dB
4960.00	Peak	46.24	3.21	49.45	74.00	-24.55
4960.00	Average	42.08	3.21	45.30	54.00	-8.70
7440.00	Peak	37.02	8.92	45.94	74.00	-28.06
7440.00	Average	34.33	8.92	43.25	54.00	-10.75

- End of Test Report -