

RADIO TEST REPORT

FCC 47 CFR PART 15 SUBPART C

Test Standard	FCC Part 15.247
Product name	Wireless Communication Cradle
Brand Name	ZEBEX
Model No.	RS-95
Test Result	Pass
Statements of Conformity	Determination of compliance is based on the results of the compliance measurement, not taking into account measurement instrumentation uncertainty.

The test Result was tested by Compliance Certification Services Inc. The test data, data evaluation, test procedures, and equipment configurations shown in this report were given in ANSI C63.10: 2013 and compliance standards.

The test results of this report relate only to the tested sample (EUT) identified in this report.

The test Report of full or partial shall not copy. Without written approval of Compliance Certification Services Inc.(Wugu Laboratory)

Approved by:



Shawn Wu
Supervisor

Unless otherwise stated the results shown in this test report refer only to the sample(s) tested and such sample(s) are retained for 90 days only.
除非另有說明，此報告結果僅對測試之樣品負責，同時此樣品僅保留90天。本報告未經本公司書面許可，不可部份複製。

This document is issued by the Company subject to its General Conditions of Service printed overleaf, available on request or accessible at <http://www.sgs.com.tw/Terms-and-Conditions> and, for electronic format documents, subject to Terms and Conditions for Electronic Documents at <http://www.sgs.com.tw/Terms-and-Conditions>. Attention is drawn to the limitation of liability, indemnification and jurisdiction issues defined therein. Any holder of this document is advised that information contained hereon reflects the Company's findings at the time of its intervention only and within the limits of client's instruction, if any. The Company's sole responsibility is to its Client and this document does not exonerate parties to a transaction from exercising all their rights and obligations under the transaction documents. This document cannot be reproduced, except in full, without prior written approval of the Company. Any unauthorized alteration, forgery or falsification of the content or appearance of this document is unlawful and offenders may be prosecuted to the fullest extent of the law.

Revision History

Rev.	Issue Date	Revisions	Effect Page	Revised By
00	June 7, 2024	Initial Issue	ALL	Peggy Tsai
01	July 3, 2024	See the following Note Rev. (01)	P.4, 11, 35, 64, 65	Peggy Tsai
02	July 9, 2024	See the following Note Rev. (02)	P.4, 16, 25, 32, 34, 36, 38, 44	Peggy Tsai
03	July 15 2024	See the following Note Rev. (03)	P. 49, A-3	Peggy Tsai
04	July 17 2024	See the following Note Rev. (04)	P. 50	Peggy Tsai

Note:

Rev. (01)

1. Added EUT Serial #: P90PH000001.
2. Modify support and EUT accessories equipment in section 1.8.
3. Modify test data in section 4.4.4.
4. Modify TX test data in section 4.8.4.

Rev. (02)

1. Modify date of test in section 1.1.
2. Modify date of RF Conducted test.

Rev. (03)

1. Modify test procedure in section 4.8.2.
2. Modify conducted emission set up photo.

Rev. (04)

1. Modify test procedure in section 4.8.2.

Table of contents

1.	GENERAL INFORMATION	4
1.1	EUT INFORMATION	4
1.2	INFORMATION ABOUT THE FHSS CHARACTERISTICS.....	5
1.3	EUT CHANNEL INFORMATION	6
1.4	ANTENNA INFORMATION	6
1.5	MEASUREMENT UNCERTAINTY	7
1.6	FACILITIES AND TEST LOCATION	8
1.7	INSTRUMENT CALIBRATION.....	9
1.8	SUPPORT AND EUT ACCESSORIES EQUIPMENT	11
1.9	TEST SET UP DIAGRAM.....	12
1.10	TEST METHODOLOGY AND APPLIED STANDARDS	12
2.	TEST SUMMERY	13
3.	DESCRIPTION OF TEST MODES	14
3.1	THE WORST MODE OF OPERATING CONDITION	14
3.2	THE WORST MODE OF MEASUREMENT	15
3.3	EUT DUTY CYCLE.....	16
4.	TEST RESULT	19
4.1	AC POWER LINE CONDUCTED EMISSION	19
4.2	20DB BANDWIDTH AND OCCUPIED BANDWIDTH (99%)	24
4.3	OUTPUT POWER MEASUREMENT.....	31
4.4	FREQUENCY SEPARATION.....	33
4.5	NUMBER OF HOPPING.....	36
4.6	CONDUCTED BANDEDGE AND SPURIOUS EMISSION	38
4.7	TIME OF OCCUPANCY (DWELL TIME).....	43
4.8	RADIATION BANDEDGE AND SPURIOUS EMISSION	48
	APPENDIX A – PHOTOGRAPHS OF EUT.....	A-1

1. GENERAL INFORMATION

1.1 EUT INFORMATION

Applicant	ZEBEX INDUSTRIES INC. B1F.-1, No. 207, Sec. 3, Beixin Rd, Xindian Dist, New Taipei City 23143, Taiwan
Manufacturer	ZEBEX INDUSTRIES INC. B1F.-1, No. 207, Sec. 3, Beixin Rd, Xindian Dist, New Taipei City 23143, Taiwan
Equipment	Wireless Communication Cradle
Model	RS-95
Model Discrepancy	N/A
Brand Name	ZEBEX
Received Date	February 22, 2024
Date of Test	March 15 ~ June 19, 2024
Power Supply	Power from Adapter BILLION / BA018-050200HXX I/P: 100-240VAC, 0.5A, 50/60Hz O/P: 5.0VDC, 2.0A
EUT Serial #	P90PH000001
HW Version	02R-S95001-024
SW Version	Model:Z319xCR (Ha2.06)U Ver:03.01 Date:08/21/2023

Remark:

1. For more details, please refer to the User's manual of the EUT.
2. Disclaimer: Antenna information is provided by the applicant, test results of this report are applicable to the sample EUT received.

1.2 INFORMATION ABOUT THE FHSS CHARACTERISTICS

1.2.1 Pseudorandom Frequency Hopping Sequence

The channel is represented by a pseudo-random hopping sequence hopping through the 79 RF channels. The hopping sequence is unique for the piconet and is determined by the Bluetooth device address of the master; the phase in the hopping sequence is determined by the Bluetooth clock of the master. The channel is divided into time slots where each slot corresponds to an RF hop frequency. Consecutive hops correspond to different RF hop frequencies. The nominal hop rate is 1 600 hops/s.

1.2.2 Equal Hopping Frequency Use

The channels of this system will be used equally over the long-term distribution of the hopsets.

1.2.3 Example of a 79 hopping sequence in data mode:

02, 05, 31, 24, 20, 10, 43, 36, 30, 23, 40, 06, 21, 50, 44, 09, 71, 78, 01, 13, 73, 07, 70, 72, 35, 62, 42, 11, 41, 08, 16, 29, 60, 15, 34, 61, 58, 04, 67, 12, 22, 53, 57, 18, 27, 76, 39, 32, 17, 77, 52, 33, 56, 46, 37, 47, 64, 49, 45, 38, 69, 14, 51, 26, 79, 19, 28, 65, 75, 54, 48, 03, 25, 66, 05, 16, 68, 74, 59, 63, 55

1.2.4 System Receiver Input Bandwidth

Each channel bandwidth is 1MHz.

The system receivers have input bandwidths that match the hopping channel bandwidths of their corresponding transmitters and shift frequencies in synchronization with the transmitted signals.

1.2.5 Equipment Description

The Rx input bandwidths shift frequencies in synchronization with the transmitted signals.

In accordance with the Bluetooth Industry Standard, the system is designed to comply with all of the regulations in standard when the transmitter is presented with a continuous data (or information) system.

In accordance with the Bluetooth Industry Standard, the system does not coordinate its channels selection/ hopping sequence with other frequency hopping systems for the express purpose of avoiding the simultaneous occupancy of individual hopping frequencies by multiple transmitters.

1.3 EUT CHANNEL INFORMATION

Frequency Range	2402MHz-2480MHz
Modulation Type	1. GFSK for BDR-1Mbps 2. $\pi/4$ -DQPSK for EDR-2Mbps 3. 8DPSK for EDR-3Mbps
Number of channel	79 Channels

Remark:

Refer as ANSI C63.10: 2013 clause 5.6.1 Table 4 for test channels

Number of frequencies to be tested		
Frequency range in which device operates	Number of frequencies	Location in frequency range of operation
<input type="checkbox"/> 1 MHz or less	1	Middle
<input type="checkbox"/> 1 MHz to 10 MHz	2	1 near top and 1 near bottom
<input checked="" type="checkbox"/> More than 10 MHz	3	1 near top, 1 near middle, and 1 near bottom

1.4 ANTENNA INFORMATION

Antenna Type	<input checked="" type="checkbox"/> PIFA <input type="checkbox"/> PCB <input type="checkbox"/> Dipole <input type="checkbox"/> Coils
Antenna Gain	Gain: 2 dBi
Antenna Connector	N/A

Notes:

1. The antenna(s) of the EUT are permanently attached and there are no provisions for connection to an external antenna. So the EUT complies with the requirements of §15.203.

1.5 MEASUREMENT UNCERTAINTY

PARAMETER	UNCERTAINTY
AC Powerline Conducted Emission	± 2.213 dB
Channel Bandwidth	± 2.7 %
RF output power (Power Meter + Power sensor)	± 0.243 dB
Power Spectral density	± 2.739 dB
Conducted Bandedge	± 2.739 dB
Conducted Spurious Emission	± 2.742 dB
Radiated Emission_9kHz-30MHz	± 3.761 dB
Radiated Emission_30MHz-200MHz	± 3.473 dB
Radiated Emission_200MHz-1GHz	± 3.946 dB
Radiated Emission_1GHz-6GHz	± 4.797 dB
Radiated Emission_6GHz-18GHz	± 4.803 dB
Radiated Emission_18GHz-26GHz	± 3.459 dB
Radiated Emission_26GHz-40GHz	± 3.297 dB

Remark:

- 1.This uncertainty represents an expanded uncertainty expressed at approximately the 95% confidence level using a coverage factor of k=2
2. ISO/IEC 17025 requires that an estimate of the measurement uncertainties associated with the emissions test results be included in the report.

1.6 FACILITIES AND TEST LOCATION

All measurement facilities used to collect the measurement data are located at

- No.11, Wugong 6th Rd., Wugu Dist., New Taipei City, Taiwan.
- No. 12, Ln. 116, Wugong 3rd Rd., Wugu Dist., New Taipei City, Taiwan 24803

CAB identifier: TW1309

Test site	Test Engineer	Remark
AC Conduction Room	Czerny Lin	-
Radiation	Tony Chao · Ray Li	-
RF Conducted	Jerry Chang	-

Remark: The lab has been recognized as the FCC accredited lab. Under the KDB 974614 D01 and is listed in the FCC public Access Link (PAL) database, FCC Registration No. :444940, the FCC Designation No.:TW1309

1.7 INSTRUMENT CALIBRATION

Conducted_FCC/IC/NCC (All)					
Name of Equipment	Manufacturer	Model	Serial Number	Calibration Date	Calibration Due
Power Sensor	Anritsu	MA2411B	1911387	2023-07-25	2024-07-24
Power Meter	Anritsu	ML2496A	2136002	2023-11-16	2024-11-15
EXA Signal Analyzer	Keysight	N9010B	MY55460167	2024-01-03	2025-01-02
Attenuator	Marvelous Microwave Inc	MVE2213-10	08	2023-11-07	2024-11-06
Software	Radio Test Software Ver. 21 & E3-Ver: 6.11-20180413				

966A_Radiated					
Name of Equipment	Manufacturer	Model	Serial Number	Calibration Date	Calibration Due
Signal Analyzer	KEYSIGHT	N9010A	MY54200716	2023-10-13	2024-10-12
Thermo-Hygro Meter	WISEWIND	1206	D07	2023-12-08	2024-12-07
Loop Antenna	COM-POWER	AL-130	121051	2023-05-23	2024-05-22
Bi-Log Antenna	Sunol Sciences	JB3	A030105	2023-08-08	2024-08-07
Preamplifier	EMEC	EM330	060609	2024-02-21	2025-02-20
Cable	Huber+Suhner	104PEA	20995+21000+182330	2024-02-21	2025-02-20
Horn Antenna	ETC	MCTD 1209	DRH13M02003	2023-12-28	2024-12-27
Preamplifier	HP	8449B	3008A00965	2023-12-22	2024-12-21
Cable	EMCI	EMC101G	221213+221011+221012	2023-10-17	2024-10-16
Attenuator	Mini-Circuits	BW-S9W5	BWS9W5-09-966A-01	2024-02-07	2025-02-06
High Pass Filters	Titan Microwave	T04H30001800070S01	22011402-4	2023-06-17	2024-06-16
Horn Antenna	SCHWARZBECK	BBHA9170	1047	2023-12-13	2024-12-12
Pre-Amplifier	EMCI	EMC184045SE	980860	2023-12-12	2024-12-11
Turn Table	CCS	CC-T-1F	N/A	N.C.R	N.C.R
Controller	CCS	CC-C-1F	N/A	N.C.R	N.C.R
Antenna Tower	CCS	CC-A-1F	N/A	N.C.R	N.C.R
Site Validation	CCS	966A	N/A	2023-07-10	2024-07-09
Software	e3 V9-210616c				

Remark:

1. Each piece of equipment is scheduled for calibration once a year.
2. N.C.R. = No Calibration Required.

AC Mains Conduction					
Name of Equipment	Manufacturer	Model	Serial Number	Calibration Date	Calibration Due
EMI Test Receiver	R&S	ESCI	100064	2023-06-07	2024-06-06
LISN	TESEQ	LN2-16N	22012	2024-02-29	2025-02-27
Cable	EMCI	CFD300-NL	CERF	2023-06-27	2024-06-26
Software	e3 V6-110812				

Remark:

1. Each piece of equipment is scheduled for calibration once a year.
2. N.C.R. = No Calibration Required.

1.8 SUPPORT AND EUT ACCESSORIES EQUIPMENT

EUT Accessories Equipment					
No.	Equipment	Brand	Model	Series No.	FCC ID
	N/A				

Support Equipment (Conducted)					
No.	Equipment	Brand	Model	Series No.	FCC ID
1	NB(L)	Lenovo	X260	N/A	N/A
2	RJ45 to USB Cable	WHALETURN	USB cable for In counter scanner	N/A	N/A

Support Equipment (Conduction)					
No.	Equipment	Brand	Model	Series No.	FCC ID
1	NB(D)	Lenovo	ThinkPad X260	N/A	N/A
A	Adapter	BILLION	BA018-050200HXX	N/A	N/A
B	Type C Cable	WHALETURN	USB A/M TO Type C/M L=1.5M	N/A	N/A
C	RJ45 to USB Cable	WHALETURN	USB cable for In counter scanner	N/A	N/A

Support Equipment (RSE)					
No.	Equipment	Brand	Model	Series No.	FCC ID
1	NB(D)	Lenovo	ThinkPad X260	N/A	N/A
2	Adapter	Lenovo	ADLX45DLC3A	N/A	N/A
A	Adapter	BILLION	BA018-050200HXX	N/A	N/A
B	Type C Cable	WHALETURN	USB A/M TO Type C/M L=1.5M	N/A	N/A
C	RJ45 to USB Cable	WHALETURN	USB cable for In counter scanner	N/A	N/A

1.9 TEST SET UP DIAGRAM

RSE:

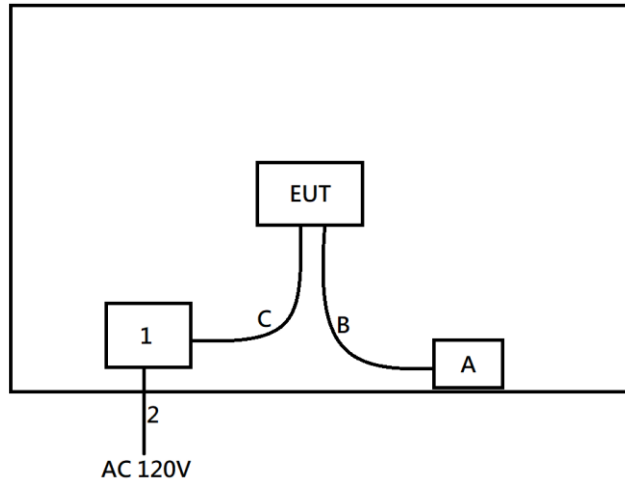

1.10 TEST METHODOLOGY AND APPLIED STANDARDS

The test methodology, setups and results comply with all requirements in accordance with ANSI C63.10:2013, FCC Part 2, FCC Part 15.247, KDB 558074.

2. TEST SUMMERY

FCC Standard Section	Report Section	Test Item	Result
15.203	1.3	Antenna Requirement	Pass
15.207(a)	4.1	AC Conducted Emission	Pass
15.247(a)(1)	4.2	20 dB Bandwidth	Pass
-	4.2	Occupied Bandwidth (99%)	Pass
15.247(b)(1)	4.3	Output Power Measurement	Pass
15.247(a)(1)	4.4	Frequency Separation	Pass
15.247(a)(1)(iii)	4.5	Number of Hopping	Pass
15.247(d)	4.6	Conducted Band Edge	Pass
15.247(d)	4.6	Conducted Spurious Emission	Pass
15.247(a)(1)(iii)	4.7	Time of Occupancy	Pass
15.247(d) 15.205, 15.209	4.8	Radiation Band Edge	Pass
15.247(d) 15.205, 15.209	4.8	Radiation Spurious Emission	Pass

3. DESCRIPTION OF TEST MODES

3.1 THE WORST MODE OF OPERATING CONDITION

<p>Operation mode</p>	<p>GFSK for BDR-1Mbps (DH5) $\pi/4$-DQPSK for 2Mbps (2DH5) 8DPSK for EDR-3Mbps (3DH5)</p>
<p>Test Channel Frequencies</p>	<p>GFSK for BDR-1Mbps: 1.Lowest Channel: 2402MHz 2.Middle Channel: 2441MHz 3.Highest Channel: 2480MHz</p> <p>$\pi/4$-DQPSK for 2Mbps: 1.Lowest Channel: 2402MHz 2.Middle Channel: 2441MHz 3.Highest Channel: 2480MHz</p> <p>8DPSK for EDR-3Mbps: 1.Lowest Channel: 2402MHz 2.Middle Channel: 2441MHz 3.Highest Channel: 2480MHz</p>

Remark:

1. EUT pre-scanned data rate of output power for each mode, the worst data rate were recorded in this report.
- 2.The system support GFSK , $\pi/4$ DQPSK ,8DPSK , the $\pi/4$ DQPSK were reduced since the identical parameters with 8dpsk. In the following test items, frequency hopping, Conducted band edge, radiated band edge and spurious emissions.

3.2 THE WORST MODE OF MEASUREMENT

AC Power Line Conducted Emission	
Test Condition	AC Power line conducted emission for line and neutral
Power supply Mode	Mode 1: EUT Power by Adapter
Worst Mode	<input checked="" type="checkbox"/> Mode 1 <input type="checkbox"/> Mode 2 <input type="checkbox"/> Mode 3 <input type="checkbox"/> Mode 4

Radiated Emission Measurement Above 1G	
Test Condition	Radiated Emission Above 1G
Power supply Mode	Mode 1: EUT power by Adapter
Worst Mode	<input checked="" type="checkbox"/> Mode 1 <input type="checkbox"/> Mode 2 <input type="checkbox"/> Mode 3 <input type="checkbox"/> Mode 4
Worst Position	<input type="checkbox"/> Placed in fixed position. <input checked="" type="checkbox"/> Placed in fixed position at X-Plane (E2-Plane) <input type="checkbox"/> Placed in fixed position at Y-Plane (E1-Plane) <input type="checkbox"/> Placed in fixed position at Z-Plane (H-Plane)

Radiated Emission Measurement Below 1G	
Test Condition	Radiated Emission Below 1G
Power supply Mode	Mode 1: EUT power by Adapter
Worst Mode	<input checked="" type="checkbox"/> Mode 1 <input type="checkbox"/> Mode 2 <input type="checkbox"/> Mode 3 <input type="checkbox"/> Mode 4

Remark:

1. The worst mode was record in this test report.
2. AC power line conducted emission and for below 1G radiation emission were performed the EUT transmit at the highest output power channel as worse case.
3. EUT pre-scanned in three axis ,X,Y, Z and two polarity, for radiated measurement. The worst case(X-Plane) were recorded in this report

3.3 EUT DUTY CYCLE

Temperature: 20.4 ~ 23.3°C

Test date: March 15 ~ June 19, 2024

Humidity: 57 ~ 58% RH

Tested by: Jerry Chang

	Duty Cycle (%) = Ton / (Ton+Toff)	Duty Factor (dB) =10*log (1/Duty Cycle)	1/T (kHz)	VBW setting (kHz)
DH1	30.80	5.11	2.60	3.00
DH3	65.60	1.83	0.61	1.00
DH5	77.20	1.12	0.35	1.00
2DH1	31.60	5.00	2.53	3.00
2DH3	66.00	1.80	0.61	1.00
2DH5	76.80	1.15	0.35	1.00
3DH1	31.20	5.06	2.56	3.00
3DH3	65.60	1.83	0.61	1.00
3DH5	76.80	1.15	0.35	1.00

Report No.: TMWK2402000535KR

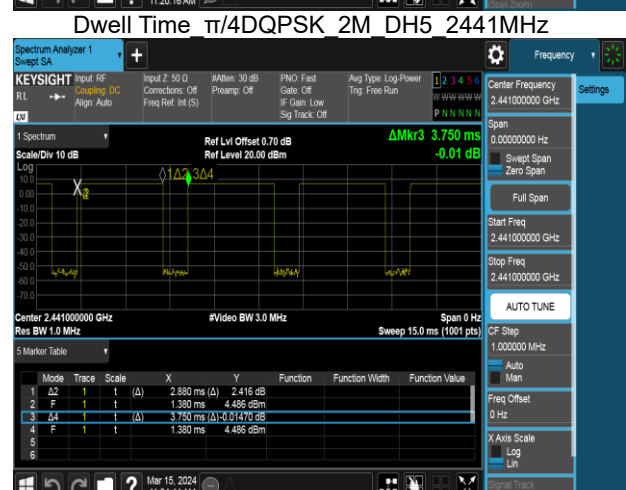
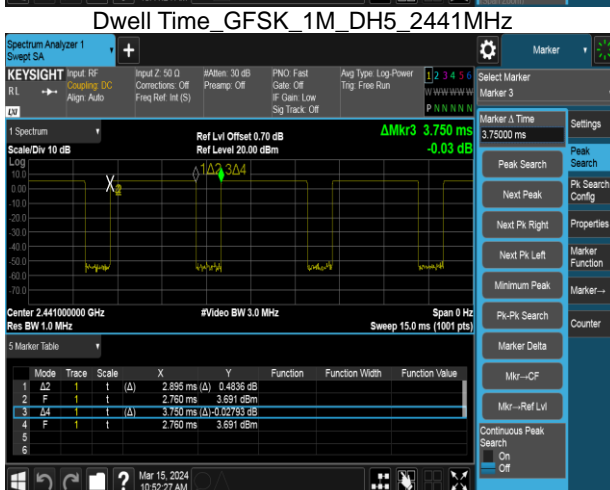
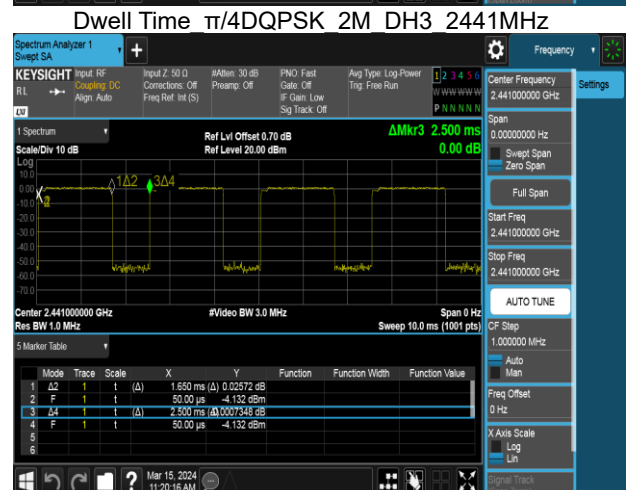
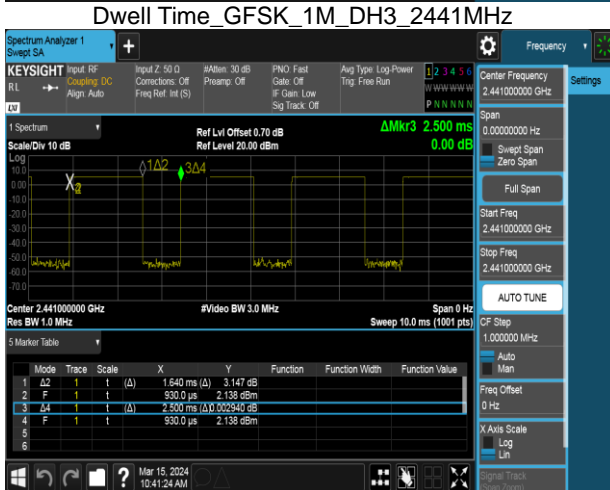
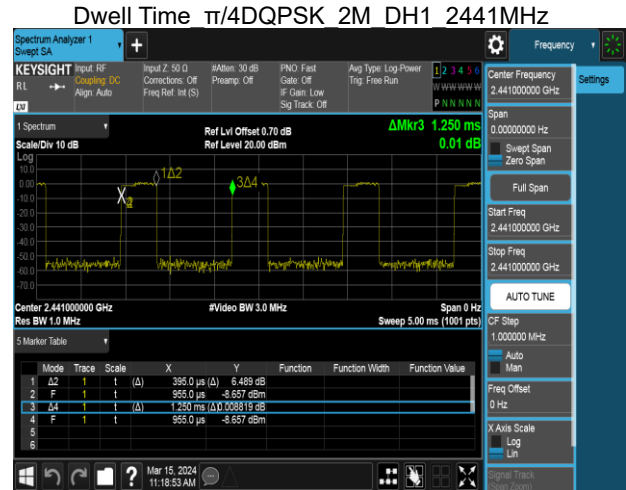
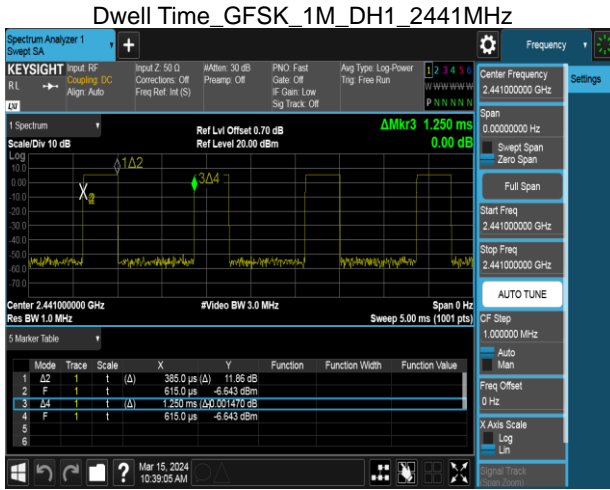

Dwell Time 8DPSK 3M DH1 2441MHz

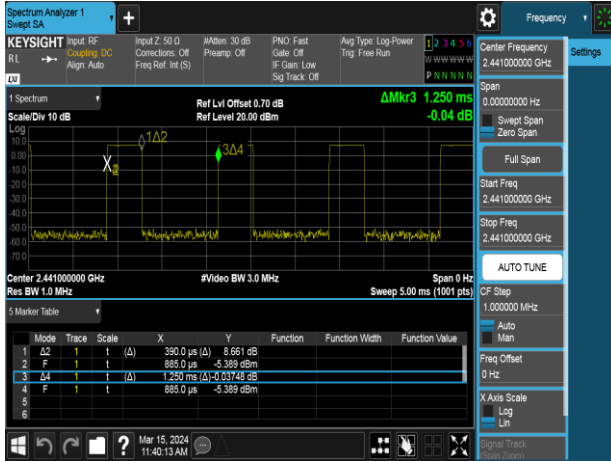

Dwell Time 8DPSK 3M DH3 2441MHz

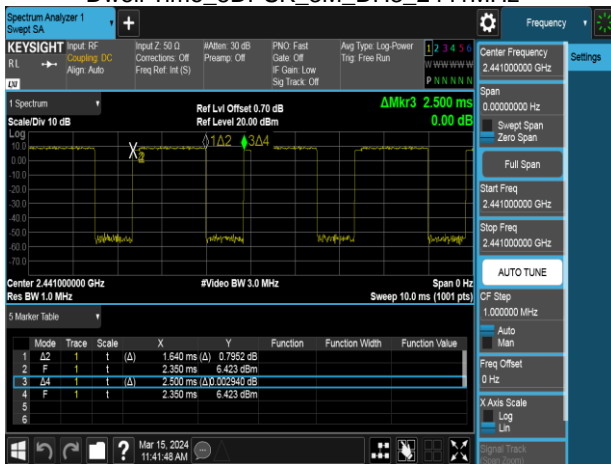

Dwell Time 8DPSK 3M DH5 2441MHz

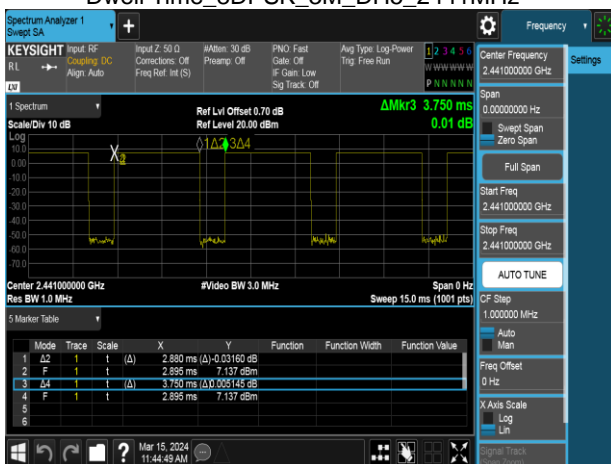

4. TEST RESULT

4.1 AC POWER LINE CONDUCTED EMISSION

4.1.1 Test Limit

According to §15.207(a),

Frequency Range (MHz)	Limits(dBµV)	
	Quasi-peak	Average
0.15 to 0.50	66 to 56*	56 to 46*
0.50 to 5	56	46
5 to 30	60	50

* Decreases with the logarithm of the frequency.

4.1.2 Test Procedure

Test method Refer as ANSI C63.10: 2013 clause 6.2,

1. The EUT was placed on a non-conducted table, which is 0.8m above horizontal ground plane and 0.4m above vertical ground plane.
2. EUT connected to the line impedance stabilization network (LISN)
3. Receiver set RBW of 9kHz and Detector Peak, and note as quasi-peak and average.
4. Maximum procedure was performed on the six highest emissions to ensure EUT compliance.
5. Recorded Line for Neutral and Line.

4.1.3 Test Setup

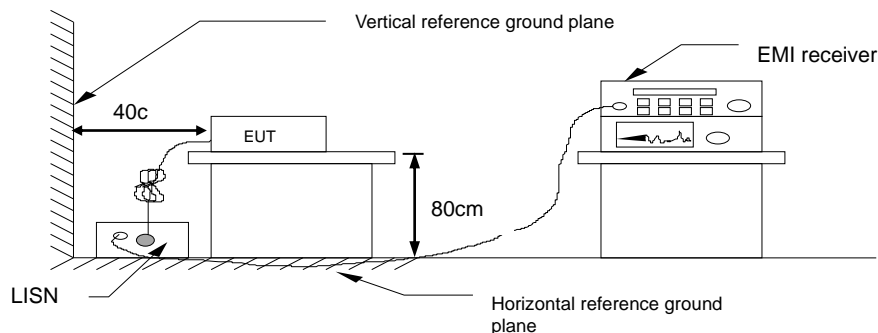

4.1.4 Test Result

PASS

Test Data

Project No	: TM-2403000256P	Test Date	: 2024-03-20
Operation Mode	: BT	Temp./Humi.	: 24.6°C / 54%
Test Chamber	: Conduction	Engineer	: Czerny Lin
Probe	: LINE	Test Voltage	: AC 120V/60Hz
Note	:		

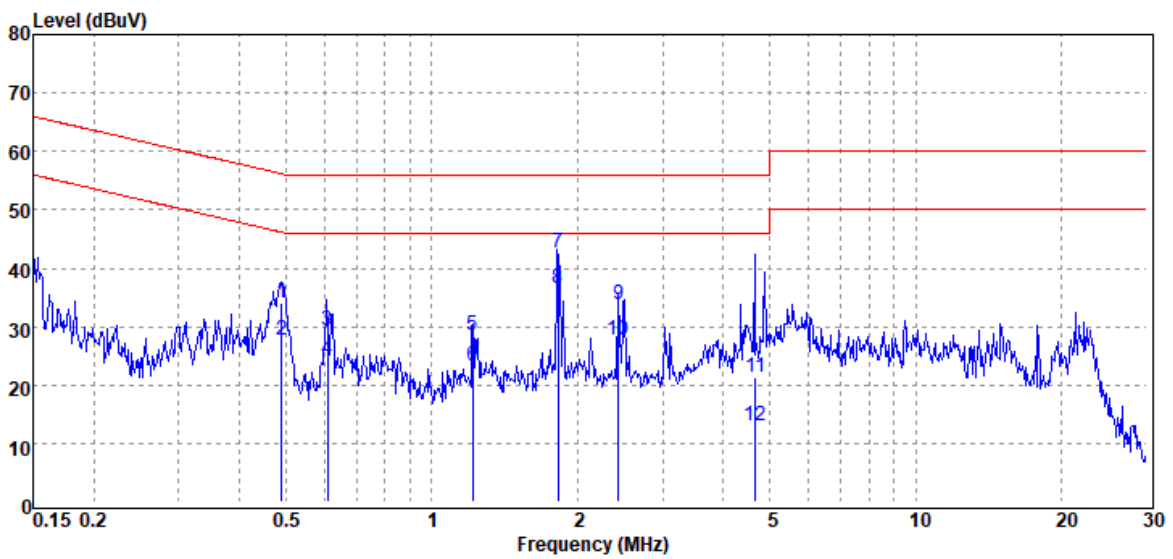

Freq. MHz	Detector Mode PK/QP/AV	Spectrum Read Level dB μ V	Factor dB	Actual FS dB μ V	Limit dB μ V	Margin dB
0.490	QP	33.95	0.15	34.10	56.17	-22.07
0.490	Average	27.54	0.15	27.69	46.17	-18.48
0.608	QP	29.21	0.15	29.36	56.00	-26.64
0.608	Average	24.17	0.15	24.32	46.00	-21.68
1.216	QP	28.44	0.18	28.62	56.00	-27.38
1.216	Average	23.06	0.18	23.24	46.00	-22.76
1.821	QP	42.51	0.21	42.72	56.00	-13.28
1.821	Average	36.29	0.21	36.50	46.00	-9.50
2.427	QP	33.66	0.24	33.90	56.00	-22.10
2.427	Average	27.31	0.24	27.55	46.00	-18.45
4.657	QP	21.08	0.27	21.35	56.00	-34.65
4.657	Average	12.70	0.27	12.97	46.00	-33.03

Note: 1. Actual FS= Spectrum Read Level + Factor

Note: 2. Margin= Actual FS – Limit

Report No.: TMWK2402000535KR

Project No : TM-2403000256P
 Operation Mode : BT
 Test Chamber : Conduction
 Probe : NEUTRAL
 Note :

Test Date : 2024-03-20
 Temp./Humi. : 24.6°C / 54%
 Engineer : Czerny Lin
 Test Voltage : AC 120V/60Hz

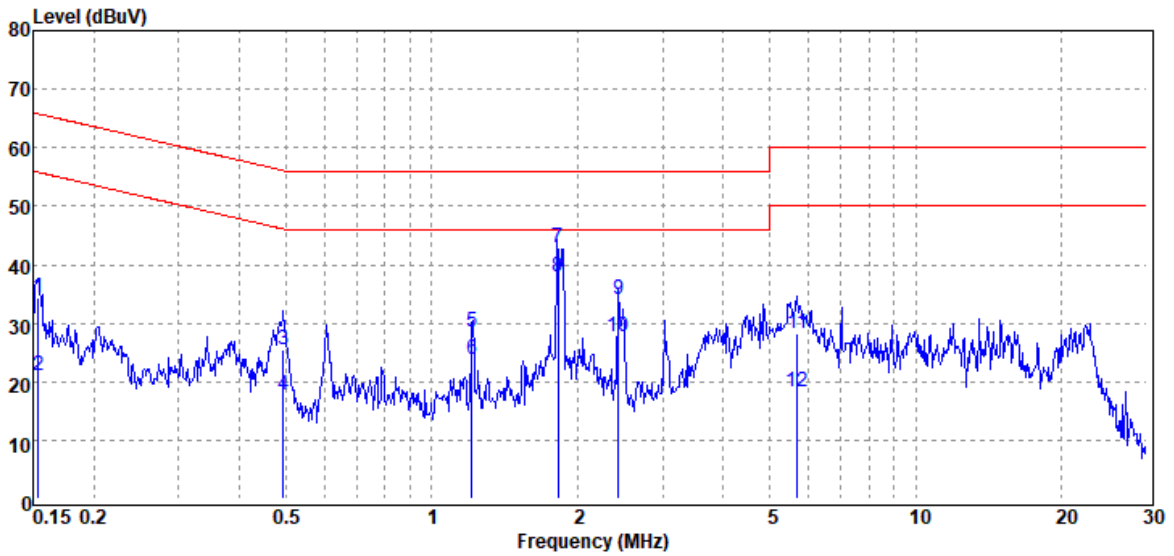

Freq. MHz	Detector Mode PK/QP/AV	Spectrum Read Level dB μ V	Factor dB	Actual FS dB μ V	Limit dB μ V	Margin dB
0.154	QP	34.02	0.20	34.22	65.79	-31.57
0.154	Average	20.88	0.20	21.08	55.79	-34.71
0.494	QP	25.21	0.19	25.40	56.10	-30.70
0.494	Average	17.44	0.19	17.63	46.10	-28.47
1.212	QP	28.39	0.22	28.61	56.00	-27.39
1.212	Average	23.49	0.22	23.71	46.00	-22.29
1.821	QP	42.67	0.25	42.92	56.00	-13.08
1.821	Average	37.71	0.25	37.96	46.00	-8.04
2.428	QP	33.76	0.28	34.04	56.00	-21.96
2.428	Average	27.48	0.28	27.76	46.00	-18.24
5.694	QP	27.76	0.34	28.10	60.00	-31.90
5.694	Average	17.83	0.34	18.17	50.00	-31.83

Note: 1. Actual FS= Spectrum Read Level + Factor

Note: 2. Margin= Actual FS – Limit

Report No.: TMWK2402000535KR

Project No : TM-2403000256P
 Operation Mode : BT
 Test Chamber : Conduction
 Probe : LINE
 Note :

Test Date : 2024-03-20
 Temp./Humi. : 24.6°C / 54%
 Engineer : Czerny Lin
 Test Voltage : AC 240V/60Hz

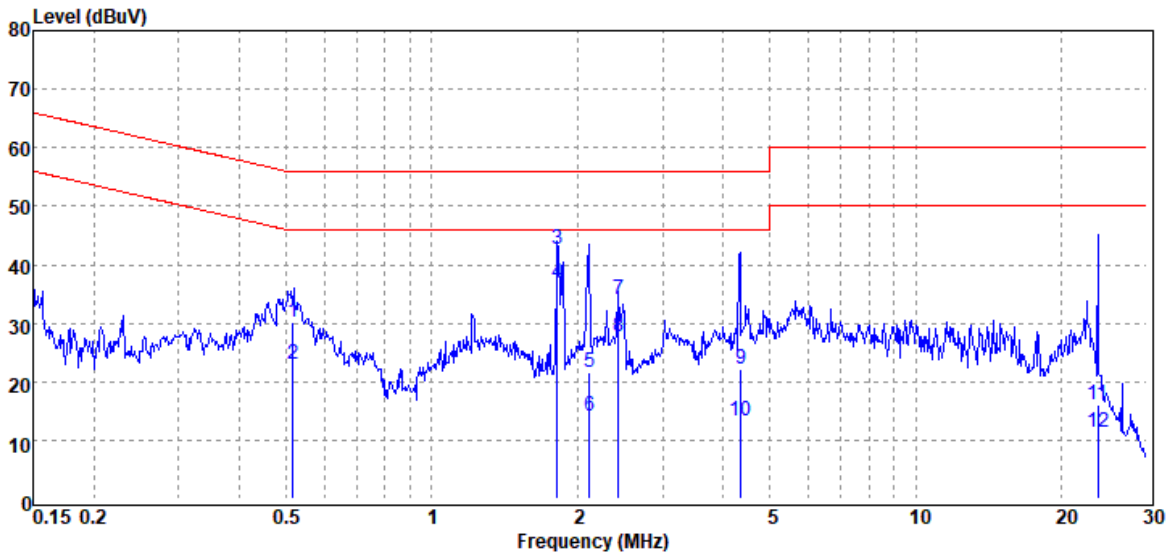

Freq. MHz	Detector Mode PK/QP/AV	Spectrum Read Level dB μ V	Factor dB	Actual FS dB μ V	Limit dB μ V	Margin dB
0.516	QP	30.05	0.15	30.20	56.00	-25.80
0.516	Average	22.79	0.15	22.94	46.00	-23.06
1.819	QP	42.55	0.21	42.76	56.00	-13.24
1.819	Average	36.49	0.21	36.70	46.00	-9.30
2.116	QP	21.48	0.22	21.70	56.00	-34.30
2.116	Average	13.92	0.22	14.14	46.00	-31.86
2.427	QP	33.72	0.24	33.96	56.00	-22.04
2.427	Average	27.35	0.24	27.59	46.00	-18.41
4.354	QP	21.98	0.27	22.25	56.00	-33.75
4.354	Average	13.05	0.27	13.32	46.00	-32.68
23.752	QP	15.50	0.56	16.06	60.00	-43.94
23.752	Average	10.67	0.56	11.23	50.00	-38.77

Note: 1. Actual FS= Spectrum Read Level + Factor

Note: 2. Margin= Actual FS – Limit

Report No.: TMWK2402000535KR

Project No : TM-2403000256P
 Operation Mode : BT
 Test Chamber : Conduction
 Probe : NEUTRAL
 Note :

Test Date : 2024-03-20
 Temp./Humi. : 24.6°C / 54%
 Engineer : Czerny Lin
 Test Voltage : AC 240V/60Hz

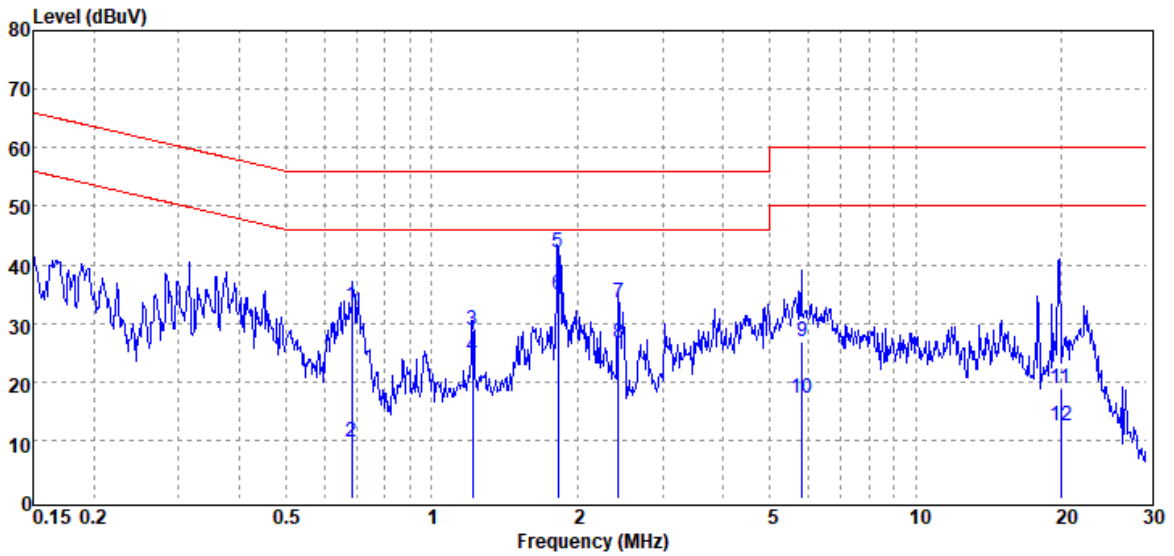

Freq. MHz	Detector Mode PK/QP/AV	Spectrum Read Level dB μ V	Factor dB	Actual FS dB μ V	Limit dB μ V	Margin dB
0.683	QP	32.72	0.21	32.93	56.00	-23.07
0.683	Average	9.42	0.21	9.63	46.00	-36.37
1.215	QP	28.66	0.22	28.88	56.00	-27.12
1.215	Average	24.04	0.22	24.26	46.00	-21.74
1.824	QP	41.73	0.25	41.98	56.00	-14.02
1.824	Average	34.55	0.25	34.80	46.00	-11.20
2.429	QP	33.13	0.28	33.41	56.00	-22.59
2.429	Average	26.16	0.28	26.44	46.00	-19.56
5.822	QP	26.55	0.34	26.89	60.00	-33.11
5.822	Average	16.80	0.34	17.14	50.00	-32.86
19.930	QP	18.34	0.52	18.86	60.00	-41.14
19.930	Average	11.93	0.52	12.45	50.00	-37.55

Note: 1. Actual FS= Spectrum Read Level + Factor

Note: 2. Margin= Actual FS – Limit

4.2 20dB BANDWIDTH AND OCCUPIED BANDWIDTH (99%)

4.2.1 Test Limit

According to §15.247(a) (1),

20 dB Bandwidth : For reporting purposes only.

Occupied Bandwidth(99%) : For reporting purposes only.

4.2.2 Test Procedure

Test method Refer as ANSI C63.10: 2013 clause 7.8.7,

1. The EUT RF output connected to the spectrum analyzer by RF cable.
2. Setting maximum power transmit of EUT
3. SA set RBW = 30kHz, VBW = 100kHz and Detector = Peak, to measurement 20 dB Bandwidth and 99% Bandwidth.
4. Measure and record the result of 20 dB Bandwidth and 99% Bandwidth. In the test report.

4.2.3 Test Setup

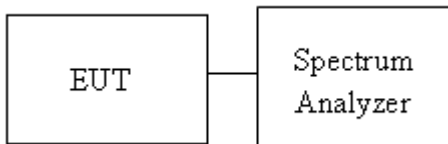

4.2.4 Test Result

Temperature: 20.4 ~ 23.3°C
Humidity: 57 ~ 58% RH

Test date: March 15 ~ June 19, 2024
Tested by: Jerry Chang

20dB BANDWIDTH

GFSK

CH	20 dB BW (MHz)	2/3 BW (MHz)
Low	0.9633	0.64
Mid	0.9631	0.64
High	0.9624	0.64

$\pi/4$ -DQPSK

CH	20 dB BW (MHz)	2/3 BW (MHz)
Low	0.694	0.46
Mid	0.697	0.46
High	0.700	0.47

8-DPSK

CH	20 dB BW (MHz)	2/3 BW (MHz)
Low	0.697	0.46
Mid	0.697	0.46
High	0.695	0.46

BANDWIDTH 99%

GFSK

CH	99% BW (MHz)
Low	0.8619
Mid	0.86239
High	0.85992

$\pi/4$ -DQPSK

CH	99% BW (MHz)
Low	0.8223
Mid	0.8264
High	0.8244

8-DPSK

CH	99% BW (MHz)
Low	0.7703
Mid	0.7743
High	0.7736

Report No.: TMWK2402000535KR

Test Data

20dB BANDWIDTH

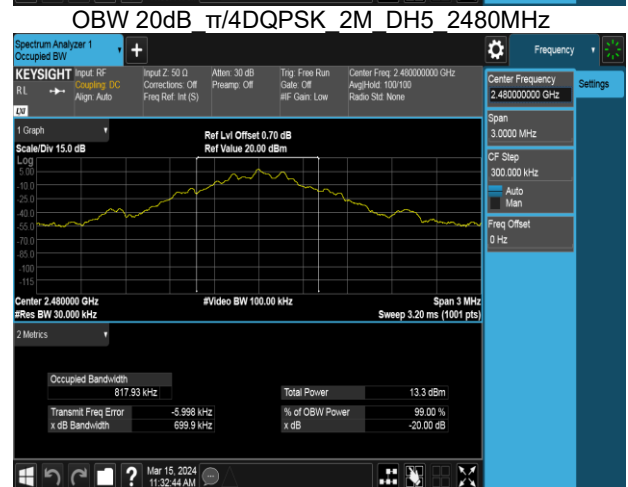
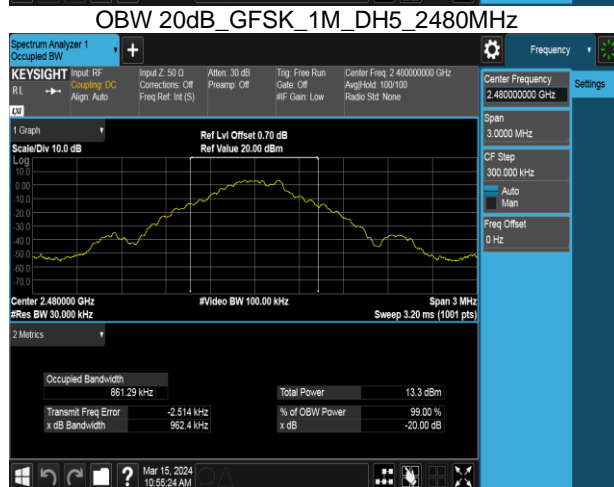
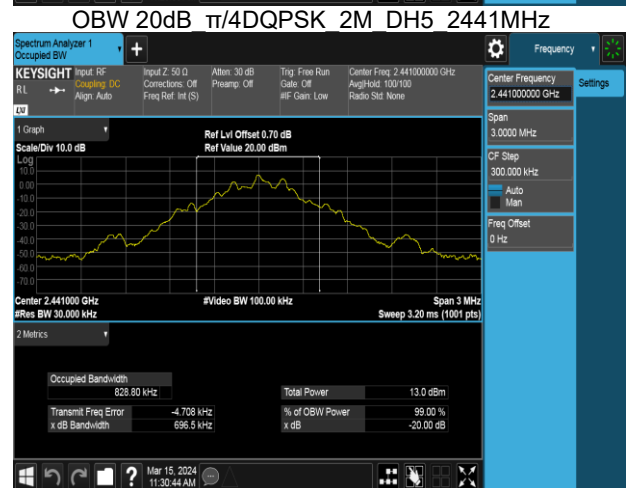
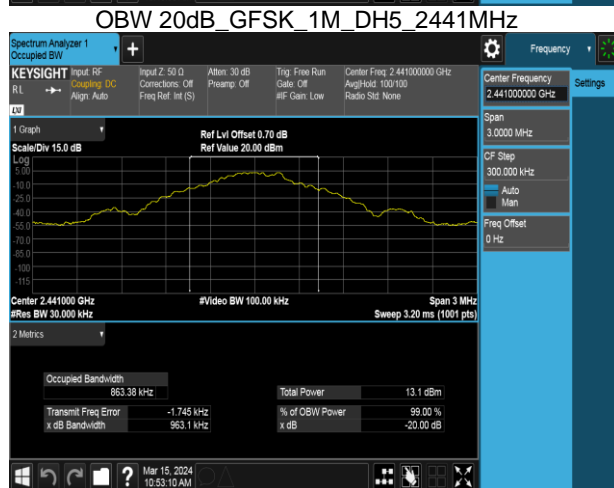
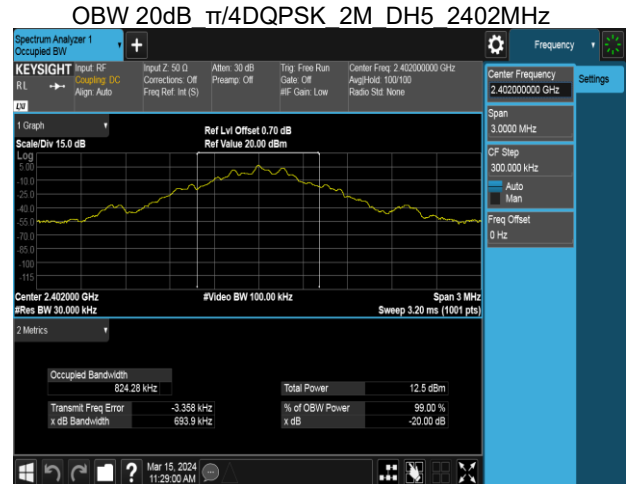
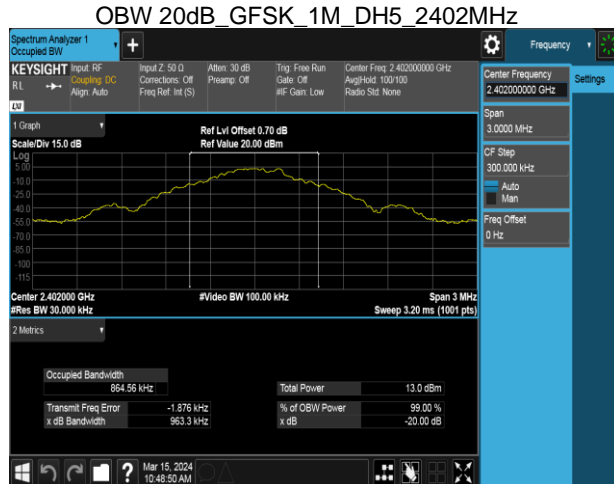

OBW 20dB_8DPSK_3M_DH5_2402MHz

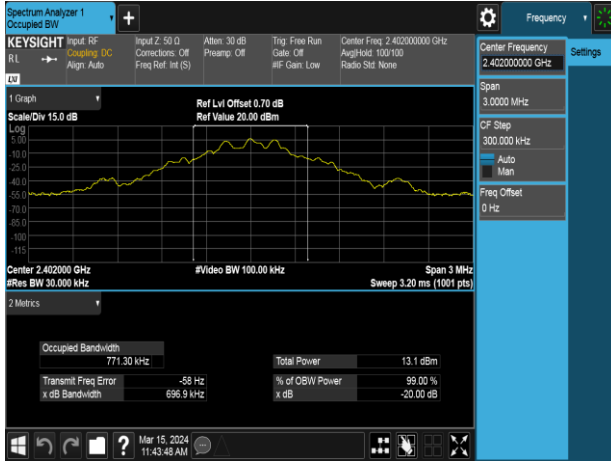

OBW 20dB_8DPSK_3M_DH5_2441MHz

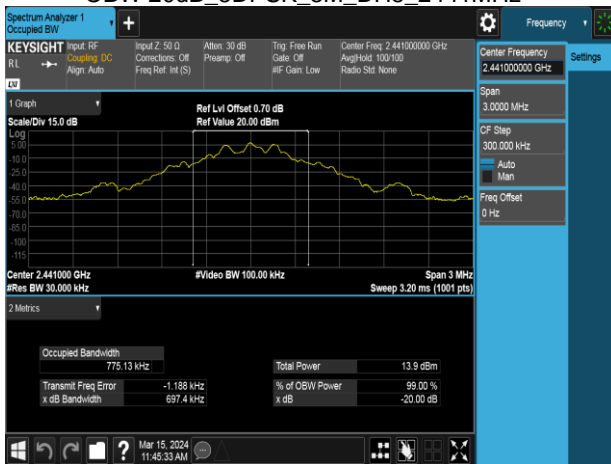

OBW 20dB_8DPSK_3M_DH5_2480MHz

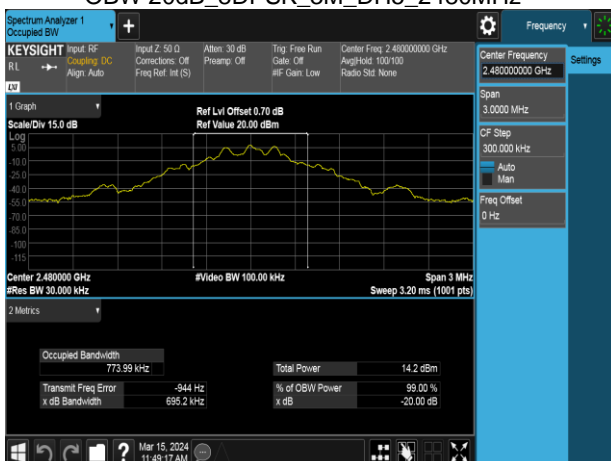

Test Data

BANDWIDTH 99%

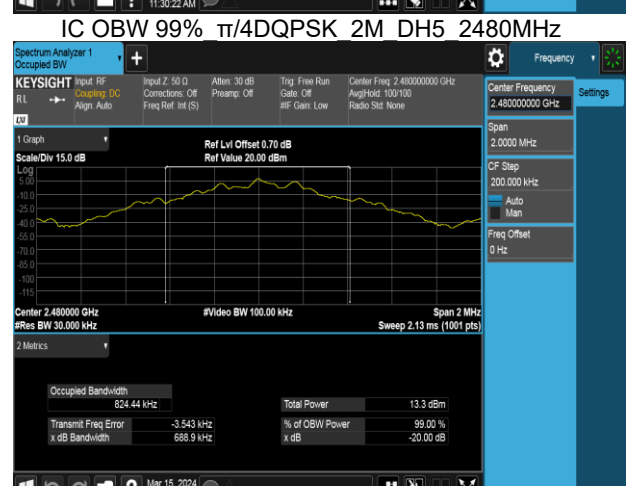
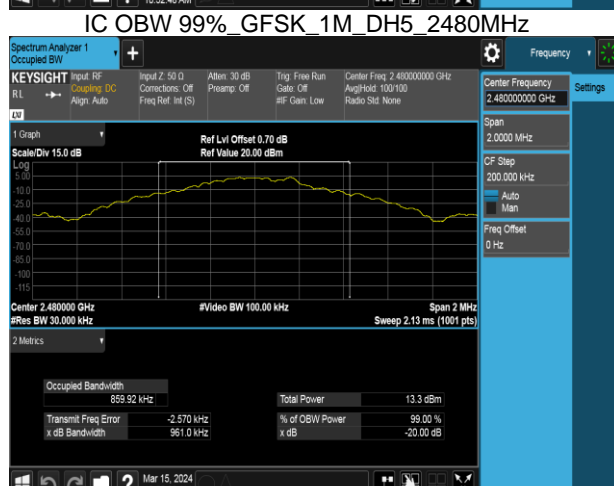
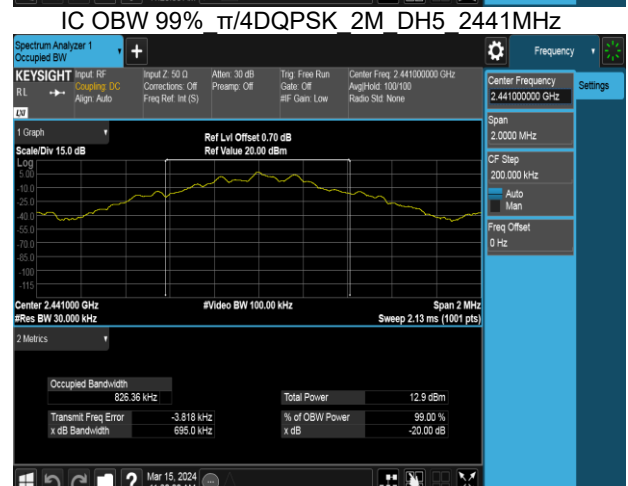
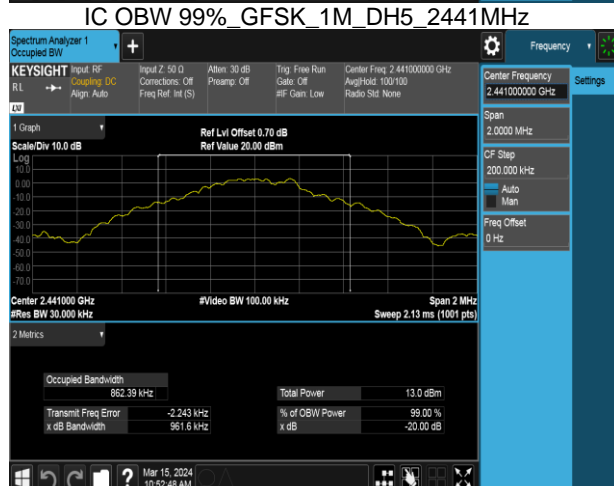
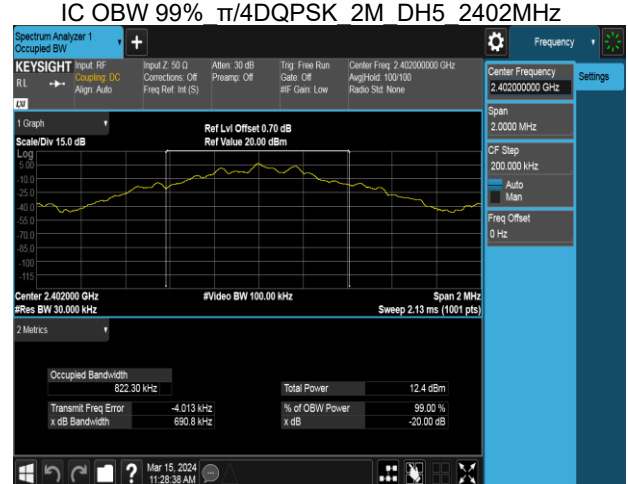
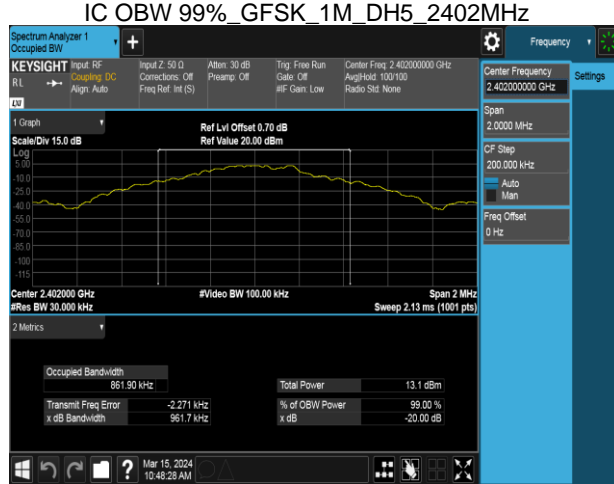

IC OBW 99% 8DPSK 3M_DH5_2402MHz

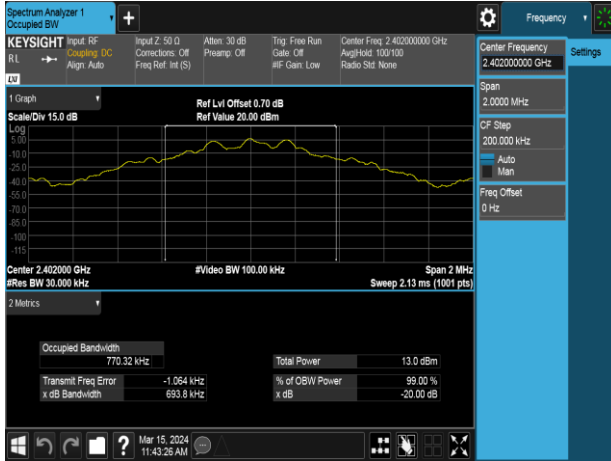

IC OBW 99% 8DPSK 3M_DH5_2441MHz

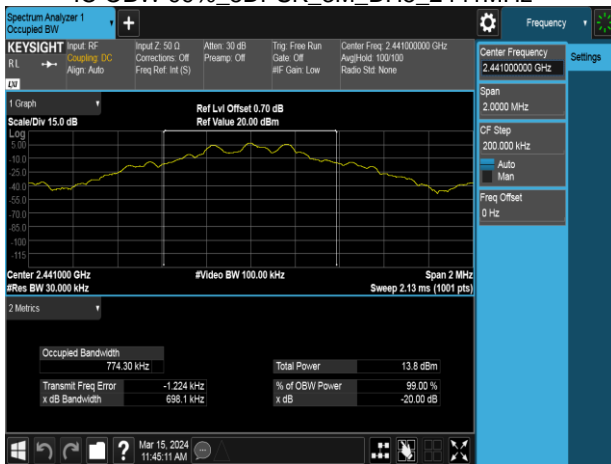

IC OBW 99% 8DPSK 3M_DH5_2480MHz

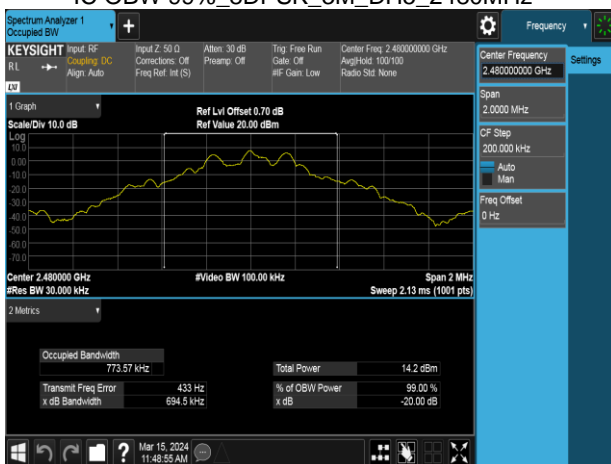

4.3 OUTPUT POWER MEASUREMENT

4.3.1 Test Limit

According to §15.247(a)(1),

Peak output power :

FCC

For frequency hopping systems operating in the 2400-2483.5 MHz band employing at least 75 non-overlapping hopping channels, and all frequency hopping systems in the 5725-5850 MHz band: 1 watt. For all other frequency hopping systems in the 2400-2483.5 MHz band: 0.125 watts.

Average output power : For reporting purposes only.

4.3.2 Test Procedure

1. The EUT RF output connected to the power meter by RF cable.
2. Setting maximum power transmit of EUT.
3. The path loss was compensated to the results for each measurement.
4. Measure and record the result of Peak output power and Average output power. In the test report.

4.3.3 Test Setup

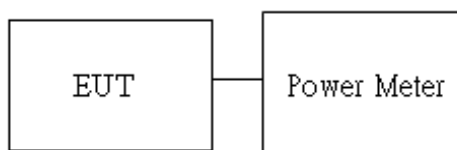

4.3.4 Test Result

Temperature: 20.4 ~ 23.3°C
Humidity: 57 ~ 58% RH

Test date: March 15 ~ June 19, 2024
Tested by: Jerry Chang

Peak & Average output power :

1M BR mode (Peak):

CH	Freq. (MHz)	Power Setting	Peak Output Power (dBm)	Output Power (mW)	Limit (mW)
Low	2402	default	7.72	5.916	1000
Mid	2441	default	7.64	5.808	1000
High	2480	default	7.47	5.585	1000

1M BR mode (Average):

CH	Freq. (MHz)	Power Setting	Avg. Output Power (dBm)	Output Power (mW)	Limit (mW)
Low	2402	default	7.68	5.867	1000
Mid	2441	default	7.55	5.694	1000
High	2480	default	7.43	5.538	1000

2M EDR mode (Peak):

CH	Freq. (MHz)	Power Setting	Peak Output Power (dBm)	Output Power (mW)	Limit (mW)
Low	2402	default	7.74	5.943	125
Mid	2441	default	7.66	5.834	125
High	2480	default	7.45	5.559	125

2M EDR mode (Average):

CH	Freq. (MHz)	Power Setting	Avg. Output Power (dBm)	Output Power (mW)	Limit (mW)
Low	2402	default	7.63	5.789	125
Mid	2441	default	7.56	5.697	125
High	2480	default	7.34	5.416	125

3M EDR mode (Peak):

CH	Freq. (MHz)	Power Setting	Peak Output Power (dBm)	Output Power (mW)	Limit (mW)
Low	2402	default	7.83	6.067	125
Mid	2441	default	7.67	5.848	125
High	2480	default	7.59	5.741	125

3M EDR mode (Average):

CH	Freq. (MHz)	Power Setting	Avg. Output Power (dBm)	Output Power (mW)	Limit (mW)
Low	2402	default	7.71	5.897	125
Mid	2441	default	7.55	5.684	125
High	2480	default	7.47	5.580	125

Note: Measured by power meter, cable loss + Duty cycle factor has been offsetted to the power meter for Avg. power and cable loss has been offsetted for Peak power measurement.

4.4 FREQUENCY SEPARATION

4.4.1 Test Limit

According to §15.247(a)(1),

Alternatively, frequency hopping systems operating in the 2400-2483.5 MHz band may have hopping channel carrier frequencies that are separated by 25 kHz or two-thirds of the 20 dB bandwidth of the hopping channel, whichever is greater, provided the systems operate with an output power no greater than 125 mW.

Limit	> two-thirds of the 20 dB bandwidth
-------	-------------------------------------

4.4.2 Test Procedure

1. Place the EUT on the table and set it in transmitting mode.
2. EUT RF output port connected to the SA by RF cable.
3. Set the spectrum analyzer as RBW = 300kHz, VBW = 910kHz, Sweep = auto.
Max hold, mark 3 peaks of hopping channel and record the 3 peaks frequency

4.4.3 Test Setup

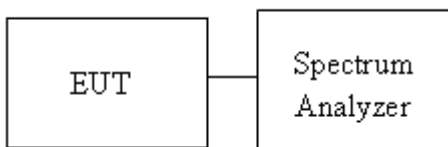

4.4.4 Test Result

Temperature: 20.4 ~ 23.3°C

Test date: March 15 ~ June 19, 2024

Humidity: 57 ~ 58% RH

Tested by: Jerry Chang

Test mode: GFSK_BDR-1Mbps mode / 2402-2480 MHz				
Channel	Frequency (MHz)	Channel Separation (MHz)	Channel Separation Limits (MHz)	Result
Low	2402	1.000	0.64	PASS
Mid	2441	1.000	0.64	PASS
High	2480	1.000	0.64	PASS

Test mode: $\pi/4$ -DQPSK_2Mbps mode / 2402-2480 MHz				
Channel	Frequency (MHz)	Channel Separation (MHz)	Channel Separation Limits (MHz)	Result
Low	2402	1.000	0.46	PASS
Mid	2441	1.000	0.46	PASS
High	2480	1.000	0.47	PASS

Test mode: 8DPSK_EDR-3Mbps mode / 2402-2480 MHz				
Channel	Frequency (MHz)	Channel Separation (MHz)	Channel Separation Limits (MHz)	Result
Low	2402	1.000	0.46	PASS
Mid	2441	1.000	0.46	PASS
High	2480	1.000	0.46	PASS

Test Data

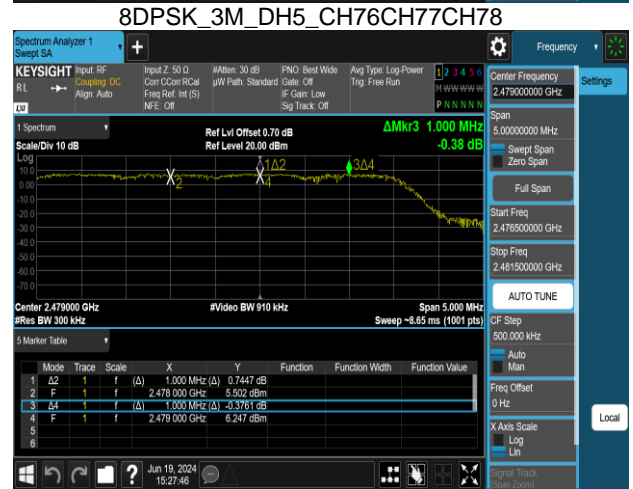
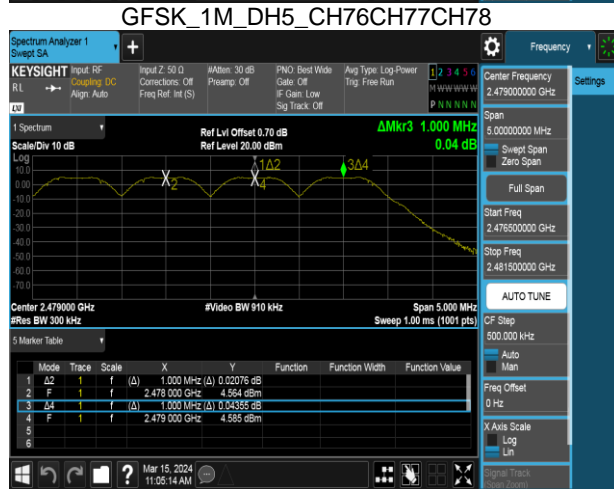
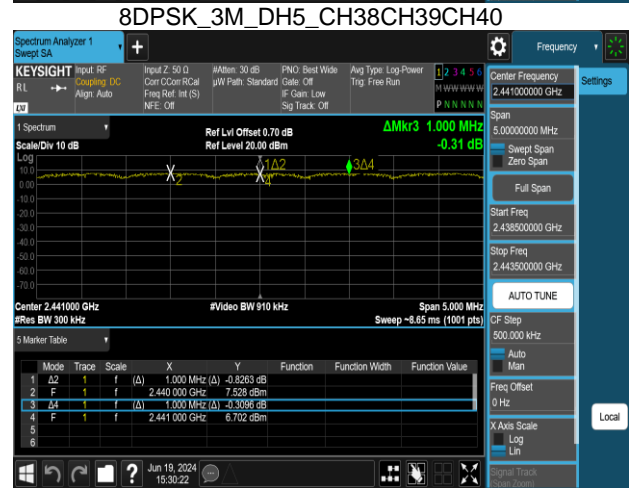
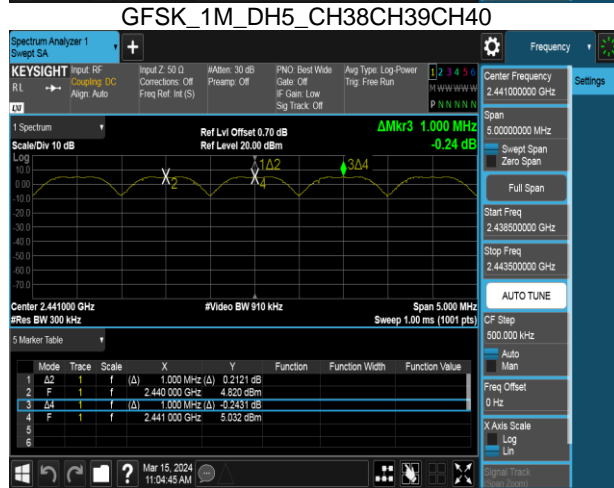
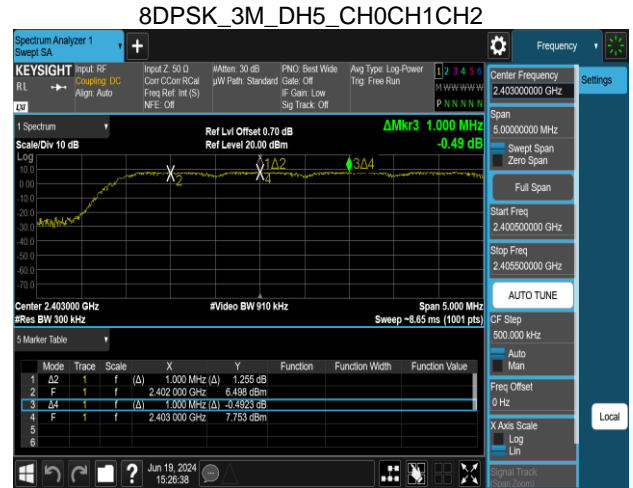
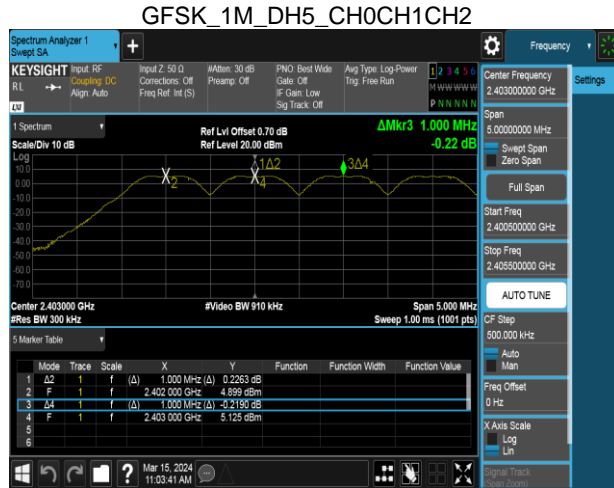

4.5 NUMBER OF HOPPING

4.5.1 Test Limit

According to §15.247(a)(1)(iii),

Frequency hopping systems in the 2400-2483.5 MHz band shall use at least 15 channels.

4.5.2 Test Procedure

Test method Refer as ANSI C63.10: 2013 clause 7.8.3

1. Place the EUT on the table and set it in transmitting mode.
2. EUT RF output port connected to the SA by RF cable.
3. Set spectrum analyzer Start Freq. = 2400 MHz, Stop Freq. = 2441 MHz, RBW=300KHz, VBW =910kHz for left half.
4. Set spectrum analyzer Start Freq. = 2441 MHz, Stop Freq. = 2483.5 MHz, RBW=300KHz, VBW =910kHz for right half.
5. Max hold, view and count how many channel in the band.

4.5.3 Test Setup

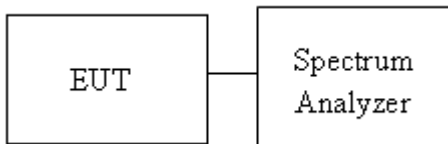

4.5.4 Test Result

Temperature: 20.4 ~ 23.3°C

Test date: March 15 ~ June 19, 2024

Humidity: 57 ~ 58% RH

Tested by: Jerry Chang

Number of Hopping				
Mode	Frequency (MHz)	Hopping Channel Number	Hopping Channel Number Limits	Result
BDR-1Mbps	2402-2480	79	15	Pass
EDR-3Mbps	2402-2480	79	15	

Report No.: TMWK2402000535KR

Test Data

GFSK_1M_DH5_2400-2441

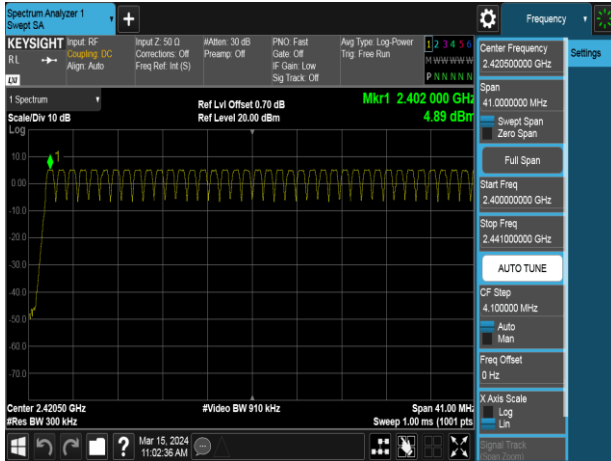

8DPSK_3M_DH5_2400-2441

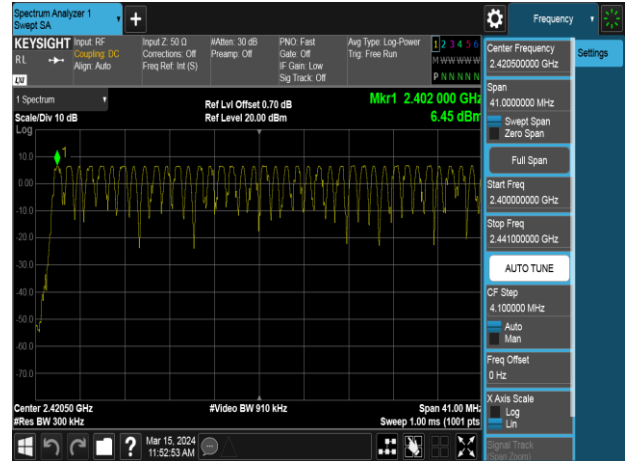

GFSK_1M_DH5_2441-2480

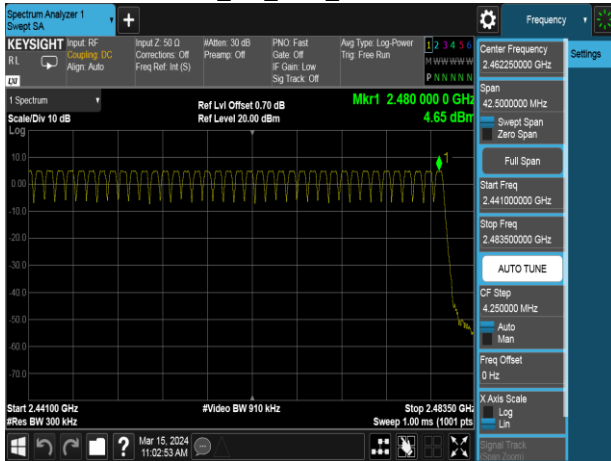

8DPSK_3M_DH5_2441-2480

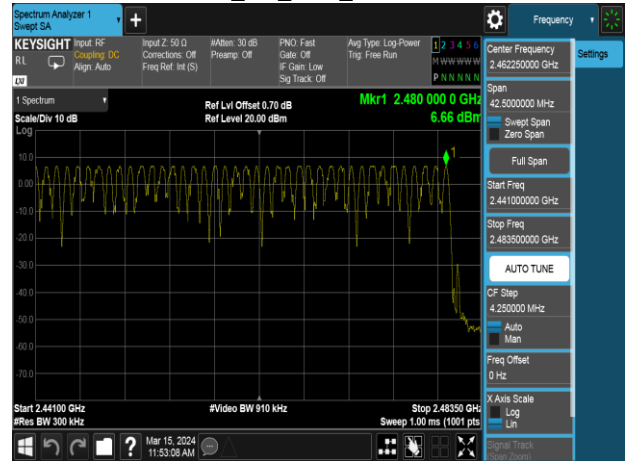

4.6 CONDUCTED BANDEDGE AND SPURIOUS EMISSION

4.6.1 Test Limit

According to §15.247(d),

Limit	-20 dBc
-------	---------

4.6.2 Test Procedure

1. EUT RF output port connected to the SA by RF cable, and the path loss was compensated to result.
2. SA setting, RBW=100kHz, VBW=300kHz, Detector=Peak, Trace mode = max hold, SWT = Auto.
3. The Band Edge at 2.4GHz and 2.4835GHz are investigated with both hopping “ON” and “OFF” modes “.

4.6.3 Test Setup

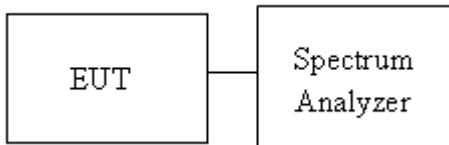

4.6.4 Test Result

Temperature: 20.4 ~ 23.3°C

Test date: March 15 ~ June 19, 2024

Humidity: 57 ~ 58% RH

Tested by: Jerry Chang

Test Data

Band Edge

Band Edge_GFSK_1M_DH5_2402MHz



Band Edge_8DPSK_3M_DH5_2402MHz

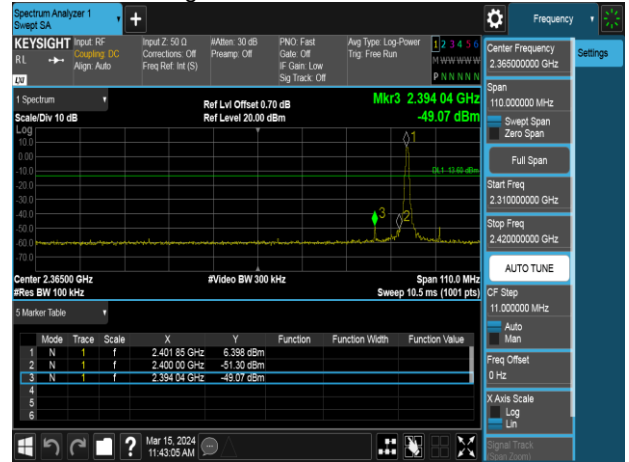

Band Edge_GFSK_1M_DH5_2480MHz



Band Edge_8DPSK_3M_DH5_2480MHz



Hopping mode

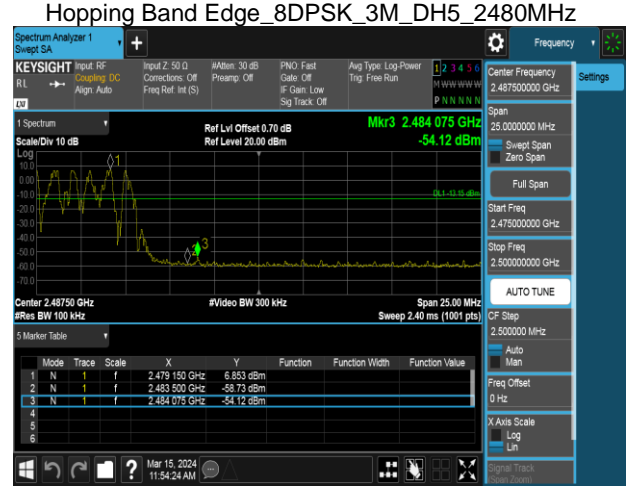
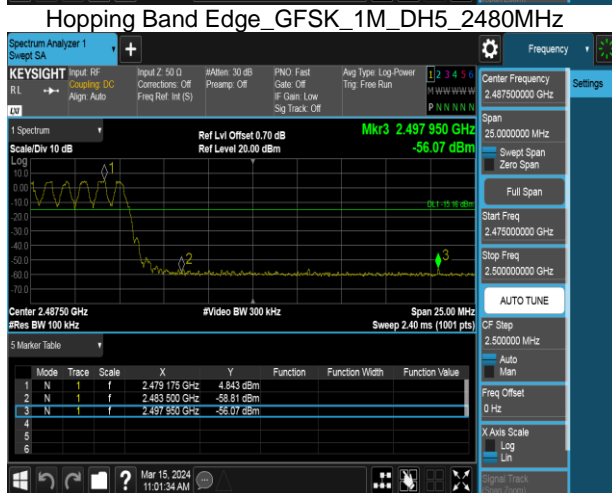
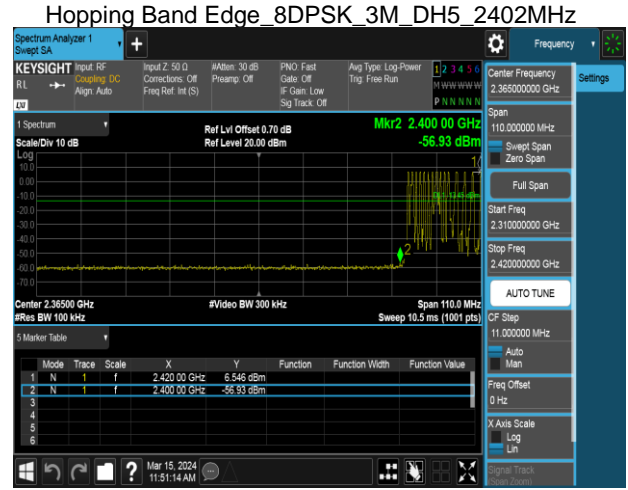
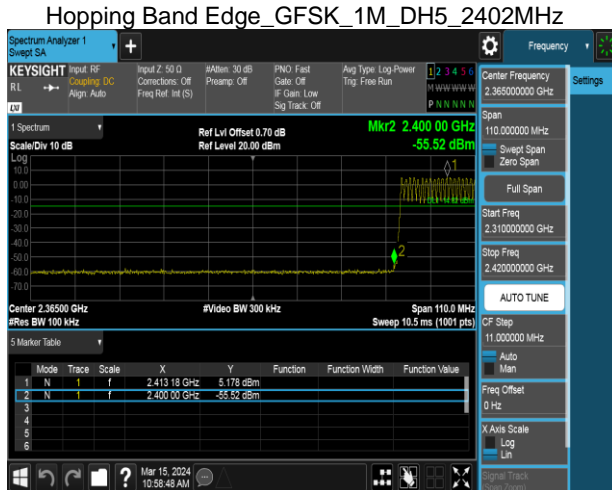

Spurious Emission

Spurious Emission_GFSK_1M_DH5_2402MHz

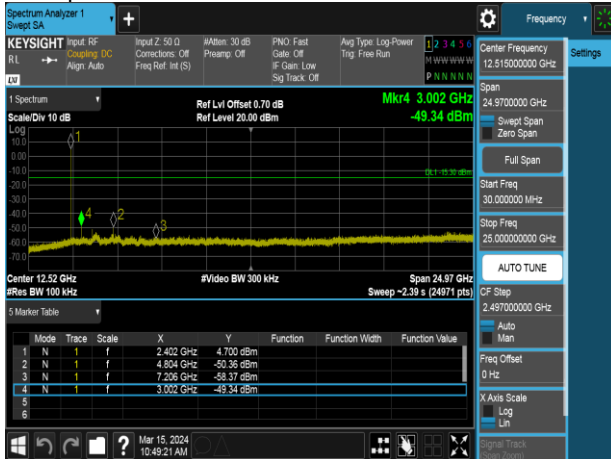

Spurious Emission π /4DQPSK 2M_DH5_2402MHz

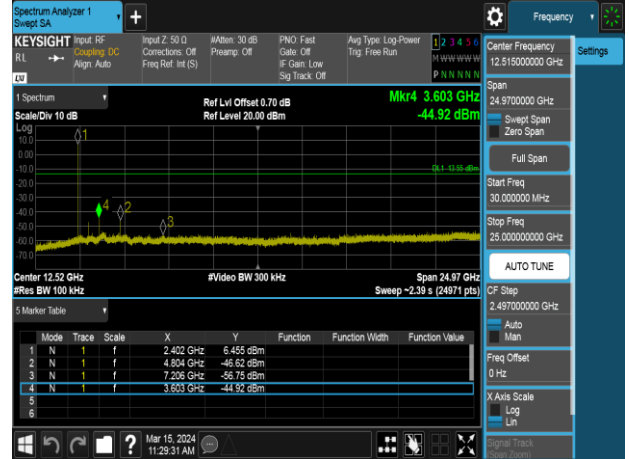

Spurious Emission_GFSK_1M_DH5_2441MHz

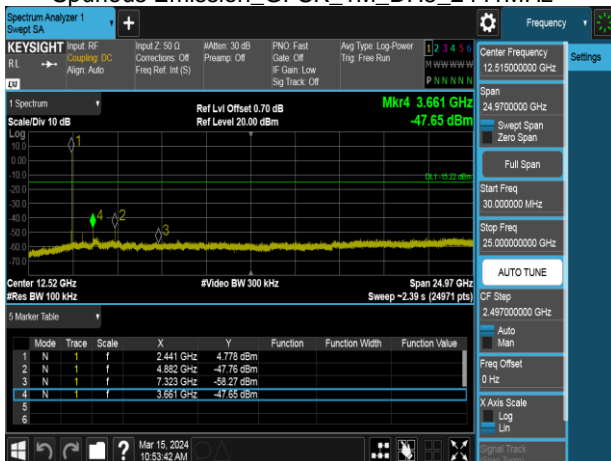

Spurious Emission π /4DQPSK 2M_DH5_2441MHz



Spurious Emission_GFSK_1M_DH5_2480MHz

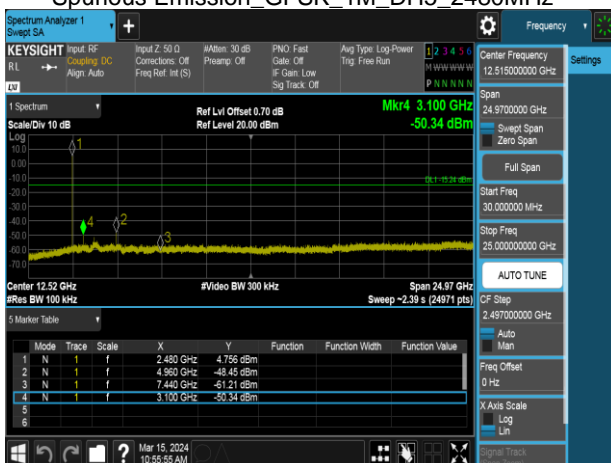

Spurious Emission π /4DQPSK 2M_DH5_2480MHz



Spurious Emission_8DPSK_3M_DH5_2402MHz

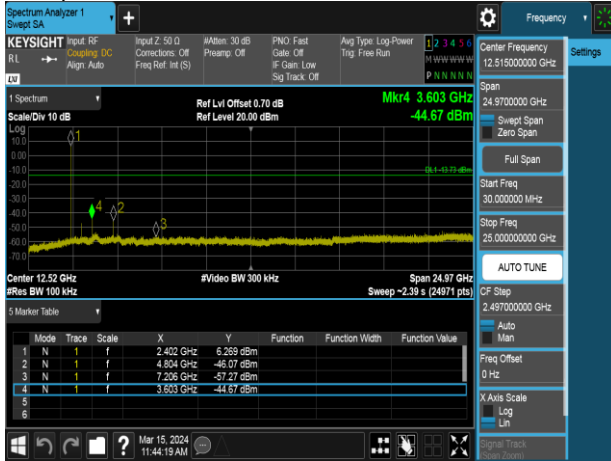

Spurious Emission_8DPSK_3M_DH5_2441MHz

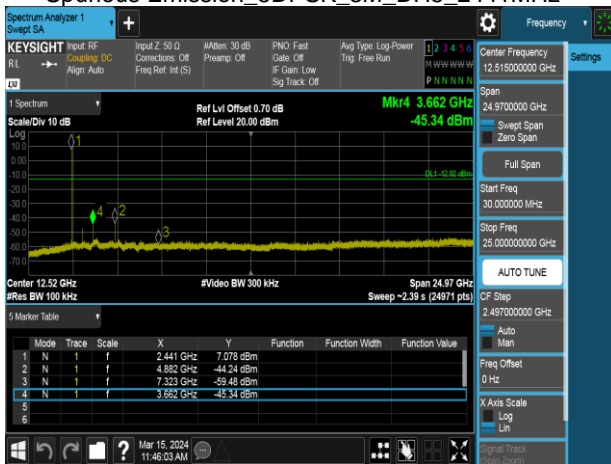

Spurious Emission_8DPSK_3M_DH5_2480MHz

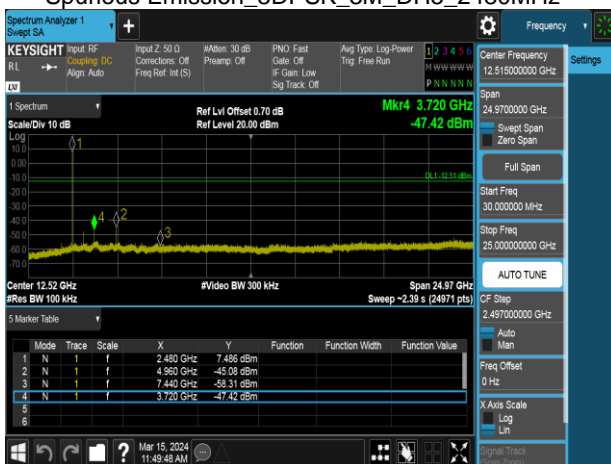

4.7 TIME OF OCCUPANCY (DWELL TIME)

4.7.1 Test Limit

According to §15.247(a)(1)(iii)

The average time of occupancy on any channel shall not be greater than 0.4 seconds within a period of 0.4 seconds multiplied by the number of hopping channels employed.

4.7.2 Test Procedure

1. EUT RF output port connected to the SA by RF cable.
2. Set center frequency of spectrum analyzer = operating frequency.
3. Set the spectrum analyzer as RBW=1MHz, VBW=3MHz, Sweep = 5 ms ~15ms(Depends on signal characteristics)

4.7.3 Test Setup

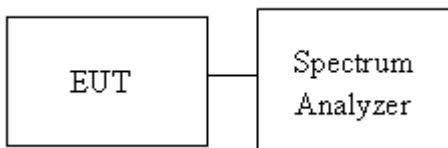

4.7.4 Test Result

Temperature: 20.4 ~ 23.3°C
Humidity: 57 ~ 58% RH

Test date: March 15 ~ June 19, 2024
Tested by: Jerry Chang

GFSK (1Mbps)

Channel	PACKET TYPE	Measurement Result (ms)	Limit (ms)
Mid	DH1	123.20	400
	DH3	262.40	400
	DH5	308.80	400

$\pi/4$ DQPSK (2Mbps)

Channel	PACKET TYPE	Measurement Result (ms)	Limit (ms)
Mid	2DH1	126.40	400
	2DH3	264.00	400
	2DH5	307.20	400

8-DPSK (3Mbps)

Channel	PACKET TYPE	Measurement Result (ms)	Limit (ms)
Mid	3DH1	124.80	400
	3DH3	262.40	400
	3DH5	307.20	400

GFSK (1Mbps):

CH Mid	DH1 time slot	=	0.385 *	(1600/2/79)	*	31.6	=	123.20 (ms)
	DH3 time slot	=	1.640 *	(1600/4/79)	*	31.6	=	262.40 (ms)
	DH5 time slot	=	2.895 *	(1600/6/79)	*	31.6	=	308.80 (ms)

$\pi/4$ -DQPSK (2Mbps):

CH Mid	2DH1 time slot	=	0.395 *	(1600/2/79)	*	31.6	=	126.40 (ms)
	2DH3 time slot	=	1.650 *	(1600/4/79)	*	31.6	=	264.00 (ms)
	2DH5 time slot	=	2.880 *	(1600/6/79)	*	31.6	=	307.20 (ms)

8-DPSK (3Mbps):

CH Mid	3DH1 time slot	=	0.390 *	(1600/2/79)	*	31.6	=	124.80 (ms)
	3DH3 time slot	=	1.640 *	(1600/4/79)	*	31.6	=	262.40 (ms)
	3DH5 time slot	=	2.880 *	(1600/6/79)	*	31.6	=	307.20 (ms)

A period time = 0.4 (s) * 79 = 31.6 (s)