



# Flom Test Labs

EMI, EMC, RF Testing Experts Since 1963

toll-free: (866) 311-3268  
fax: (480) 926-3598  
<http://www.flomlabs.com>  
[info@flomlabs.com](mailto:info@flomlabs.com)

Date: September 12, 2007

Federal Communications Commission  
Via: Electronic Filing

Attention: Authorization & Evaluation Division

Applicant: International Electronics Inc.  
Equipment: Oracle Telephone Interface  
FCC ID: JLFTIU2  
FCC Rules: 15.249

Gentlemen:

On behalf of the Applicant, enclosed please find Application Form 731, Engineering Test Report and all pertinent documentation, the whole for approval of the referenced equipment as shown.

Filing fees are attached.

We trust the same is in order. Should you need any further information, kindly contact the writer who is authorized to act as agent.

Sincerely yours,

Hoosamuddin S. Bandukwala, Lab Director



**List Of Exhibits**  
(FCC **Certification** (Transmitters) - Revised 9/28/98)

Applicant: International Electronics Inc.

FCC ID: JLFTIU2

**By Applicant:**

1. Letter Of Authorization
2. Identification Drawings
  - Label
  - Location of Label
  - Compliance Statement
  - Location of Compliance Statement
3. Documentation: 2.1033(B)
  - (3) User Manual
  - (4) Operational Description
  - (5) Block Diagram
  - (5) Schematic Diagram
  - (7) Photographs
  - Parts List
  - Active Devices

**By FTL Inc.**

- A. Testimonial & Statement of Certification
- B. Statement of Qualifications



**Flom Test Labs**  
EMI, EMC, RF Testing Experts Since 1963

toll-free: (866) 311-3268  
fax: (480) 926-3598  
<http://www.flomlabs.com>  
[info@flomlabs.com](mailto:info@flomlabs.com)

## **Transmitter Certification**

of

Model: Oracle Telephone Interface

to

**Federal Communications Commission**

Rule Part(s) 15.249

**Date Of Report:** September 12, 2007

**At the Request of:**

International Electronics Inc.  
5913-C NE 127th Ave, Suite 800  
Vancouver, WA 98682

**Attention of:**

Shary Nassimi, President  
(360) 241-9090  
email: [iei@nwlink.com](mailto:iei@nwlink.com)

**Supervised By:**

Hoosamuddin S. Bandukwala, Lab Director



The applicant has been cautioned as to the following:

15.21 Information to User.

The users manual or instruction manual for an intentional radiator shall caution the user that changes or modifications not expressly approved by the party responsible for compliance could void the user's authority to operate the equipment.

15.27(a) Special Accessories.

Equipment marketed to a consumer must be capable of complying with the necessary regulations in the configuration in which the equipment is marketed. Where special accessories, such as shielded cables and/or special connectors are required to enable an unintentional or intentional radiator to comply with the emission limits in this part, the equipment must be marketed with, i.e. shipped and sold with, those special accessories. However, in lieu of shipping or packaging the special accessories with the unintentional or intentional radiator, the responsible party may employ other methods of ensuring that the special accessories are provided to the consumer, without additional charge.

Information detailing any alternative method used to supply the special accessories for a grant of equipment authorization or retained in the verification records, as appropriate. The party responsible for the equipment, as detailed in § 2.909 of this chapter, shall ensure that these special accessories are provided with the equipment. The instruction manual for such devices shall include appropriate instructions on the first page of text concerned with the installation of the device that these special accessories must be used with the device. It is the responsibility of the user to use the needed special accessories supplied with the equipment.

## Table Of Contents

Rule	Description	Page
	Test Report	1
2.1033(c)	General Information Required	2
	Standard Test Conditions and Engineering Practices	6
2.1053(a)	Field Strength of Spurious Radiation	7
15.239	Radiated Output Power	9
15.109	Radiated Emissions	10
15.207	A/C Powerline Conducted Emissions	18

Required information per ISO 17025

**Test Report**

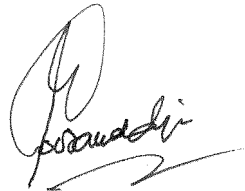
- a)
- b) Laboratory: Flom Test Labs  
(FCC: 31040/SIT) 3356 N. San Marcos Place, Suite 107  
(Canada: IC 2044) Chandler, AZ 85225
- c) Report Number: d0790008
- d) Client: International Electronics Inc.  
5913-C NE 127th Ave, Suite 800  
Vancouver, WA 98682
- e) Identification: Oracle Telephone Interface  
Description: Telephone Interface
- f) EUT Condition: Not required unless specified in individual tests.
- g) Report Date: September 12, 2007  
EUT Received: September 1, 2007
- h, j, k): As indicated in individual tests.
- i) Sampling method: No sampling procedure used.
- l) Uncertainty: In accordance with FTL internal quality manual.
- m) Supervised by:
- 
- Hoosamuddin S. Bandukwala, Lab Director
- n) Results: The results presented in this report relate only to the item tested.
- o) Reproduction: This report must not be reproduced, except in full, without written permission from this laboratory.

**List Of General Information Required For Certification**

In Accordance with FCC Rules and Regulations,  
Volume II, Part 2 and to

15.249

**Sub-Part 2.1033**

(c)(1): **Name and Address of Applicant:**

International Electronics Inc.  
5913-C NE 127th Ave, Suite 800  
Vancouver, WA 98682

(c)(2): **FCC ID:** JLFTIU2

**Model Number:** Oracle Telephone Interface

(c)(3): **Instruction Manual(s):**

Please See Attached Exhibits

(c)(4): **Type of Emission:** N/A

(c)(5): **FREQUENCY RANGE, MHz:** 903 to 926

(c)(6): **Power Rating, W:**  
 Switchable                       Variable                       N/A

(c)(7): **Maximum Power Rating, W:** 50 mV/m @ 3m

**15.203: Antenna Requirement:**

- The antenna is permanently attached to the EUT
- The antenna uses a unique coupling
- The EUT must be professionally installed
- The antenna requirement does not apply

**Subpart 2.1033** (continued)

(c)(8): Voltages & Currents in All Elements in Final RF Stage, Including Final Transistor or Solid State Device:

Collector Current, A	=	per manual
Collector Voltage, Vdc	=	per manual
Supply Voltage, Vdc	=	18

(c)(9): **Circuit Diagram/Circuit Description:**

Including description of circuitry & devices provided for determining and stabilizing frequency, for suppression of spurious radiation, for limiting modulation and limiting power.

Please See Attached Exhibits

(c)(10): **Label Information:**

Please See Attached Exhibits

(c)(11): **Photographs:**

Please See Attached Exhibits

(c)(12): **Digital Modulation Description:**

Attached Exhibits  
 N/A

(c)(13): **Test and Measurement Data:**

Follows



# A2LA

“A2LA has accredited Flom Test Labs, Inc. Chandler, AZ for technical competence in the field of Electrical Testing. The accreditation covers the specific tests and types of tests listed on the agreed scope of accreditation. This laboratory meets the requirements of ISO 17025:2005 ‘General Requirements for the Competence of Testing and Calibration Laboratories’ and any additional program requirements in the identified field of testing.”

Please refer to [www.a2la.org](http://www.a2la.org) for current scope of accreditation.

Certificate Number: **2152.01**



IC O.A.T.S. Number: 2044A-1

---

Sub-part  
 2.1033(b):

### Test and Measurement Data

All tests and measurement data shown were performed in accordance with FCC Rules and Regulations, Volume II; Part 2, Sub-part J, Sections 2.1031, 2.1033, 2.1035, 2.1041, 2.1043, 2.1045, and the following individual Parts:

_____	15.209	Radiated emission limits; general requirements
_____	15.211	Tunnel radio systems
_____	15.213	Cable locating equipment
_____	15.214	Cordless telephones
_____	15.217	Operation in the band 160-190 kHz
_____	15.219	Operation in the band 510-1705 kHz
_____	15.221	Operation in the band 525-1705 kHz (leaky coax)
_____	15.223	Operation in the band 1.705-10 MHz
_____	15.225	Operation in the band 13.553-13.567 MHz
_____	15.227	Operation in the band 26-27.28 MHz (remote control)
_____	15.229	Operation in the band 40.66-40.70 MHz
_____	15.231	Periodic operation in the band 40.66-40.70 MHz and above 70 MHz
_____	15.233	Operation within the bands 43.71-44.49, 46.60-46.98 MHz 48.75-49.51 MHz and 49.66-50.0 MHz
_____	15.235	Operation within the band 49.82-49.90 MHz
_____	15.237	Operation within the bands 72.0-73.0 MHz, 74.6-74.8 MHz and 75.2-76.0 MHz (auditory assistance)
_____	15.239	Operation in band 88-108 MHz
_____	15.241	Operation in the band 174-216 MHz (biomedical)
_____	15.243	Operation in the band 890-940 MHz (materials)
_____	15.245	Operation within the bands 902-928 MHz, 2435-2465 MHz, 5785-5815 MHz, 10500-10550 MHz, and 24075-24175 MHz (filed disturbance sensors)
_____	15.247	Operation within bands 902-928 MHz, 2400-2483.5 MHz, and 5725-5850 MHz (spread spectrum)
X	15.249	Operation within the bands 902-928 MHz, 2400-2483.5 MHz, 5725-5875 MHz, and 24.0- 24.25 GHz
_____	15.251	Operation within the bands 2.9-3.26 GHz, 3.267-3.332 GHz, 3.339-3.3458 GHz, and 3.358- 3.6 GHz (vehicle identification systems)
_____	15.321	Specific requirements for asynchronous devices operating in the 1910-1920 MHz and 2390- 2400 MHz bands (Unlicensed PCS)
_____	15.323	Specific requirements for isochronous devices operating in the 1920-1930 MHz sub-band (Unlicensed PCS)

Standard Test Conditions  
And  
Engineering Practices

Except as noted herein, the following conditions and procedures were observed during the testing:

In accordance with ANSIC63.4-2003, section 6.1.9, and unless otherwise indicated in the specific measurement results, the ambient temperature of the actual EUT was maintained within the range of 10° to 40°C (50° to 104 °F) unless the particular equipment requirements specify testing over a different temperature range. Also, unless otherwise indicated, the humidity levels were in the range of 10% to 90% relative humidity.

Prior to testing, the EUT was tuned up in accordance with the manufacturer's alignment procedures. All external gain controls were maintained at the position of maximum and/or optimum gain throughout the testing.

Measurement results, unless otherwise noted, are worst-case measurements.

**Name of Test:** Field Strength of Spurious Radiation

**Specification:** 47 CFR 2.1053(a)

**Guide:** ANSI 63.4 / 2004, 47 CFR 15.231

### Measurement Procedure

1.2.12.1 Definition: Radiated spurious emissions are emissions from the equipment when transmitting into a non-radiating load on a frequency or frequencies which are outside an occupied band sufficient to ensure transmission of information of required quality for the class of communications desired.

#### 1.2.12.2 Method of Measurement

- A) Connect the equipment as illustrated
- B) Adjust the spectrum analyzer for the following settings:
  - 1) Resolution Bandwidth 100 kHz (<1 GHz), 1 MHz (> 1GHz).
  - 2) Video Bandwidth  $\geq 3$  times Resolution Bandwidth, or 30 kHz (22.917)
  - 3) Sweep Speed  $\leq 2000$  Hz/second
  - 4) Detector Mode = Mean or Average Power
- C) Place the transmitter to be tested on the turntable in the standard test site. The transmitter is transmitting into a non-radiating load, which is placed on the turntable. The RF cable to this load should be of minimum length.

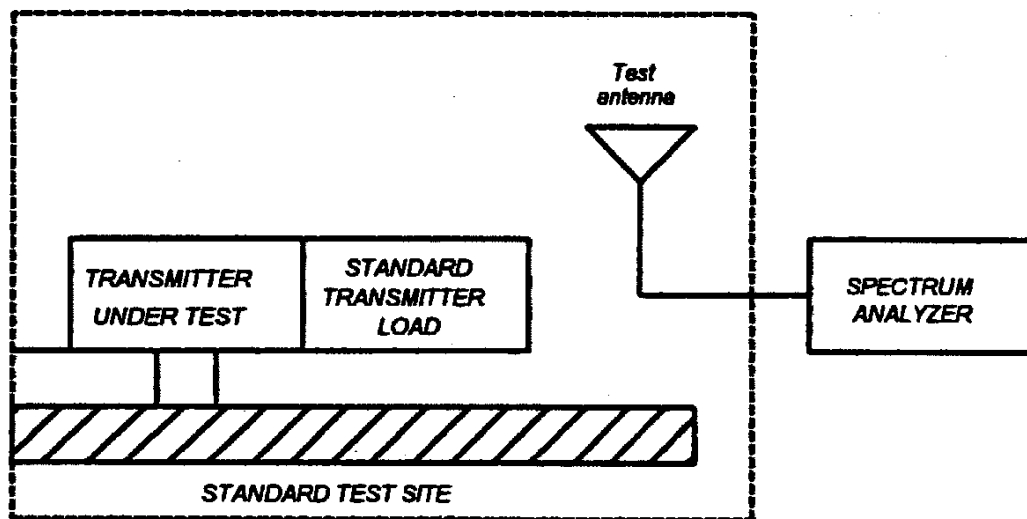

**Name of Test:** Field Strength of Spurious Radiation (Cont.)

- D) For each spurious measurement the test antenna should be adjusted to the correct length for the frequency involved. This length may be determined from a calibration ruler supplied with the equipment. Measurements shall be made from the lowest radio frequency generated in the equipment to the tenth harmonic of the carrier, except for the region close to the carrier equal to  $\pm$  the test bandwidth (see section 1.3.4.4).
- E) For each spurious frequency, raise and lower the test antenna from 1 m to 4 m to obtain a maximum reading on the spectrum analyzer with the test antenna at horizontal polarity. Repeat this procedure to obtain the highest possible reading. Record this maximum reading.
- F) Repeat step E) for each spurious frequency with the test antenna polarized vertically.

**Test equipment used**

Description	MFG	Model Number	FTL Asset Number	Last Cal Date	Cal Due Date
Bi-conical Antenna	EMCO	3109B	i00088	10/14/05	10/14/07
Log Periodic Antenna	Apriel	2001	i00089	10/20/05	10/20/07
Horn Antenna	EMCO	3115	i00103	9/5/06	9/5/07
Spectrum Analyzer	HP	8566B	i00329	4/16/07	4/16/08

In addition to the above listed equipment standard RF connectors and cables were utilized in the testing of the described equipment. Prior to testing these components were tested to verify proper operation

**Name of Test:** Radiated Output Power

State: 1:High Power

Frequency Tuned, MHz	Frequency Emission, MHz	Meter, dBuV/m	CF, dB	dBuV/m @ 3m	Limit (dBuV)	Margin, dB
903.321000	903.321000	51.5	26.10	77.6	94.0	-16.4
914.300000	914.379000	49.4	26.82	76.2	94.0	-17.8
926.700000	926.700000	48.3	27.30	75.6	94.0	-18.4

**Name of Test:** Radiated Emissions

**Specification:**

- 15.109: Radiated Interference Limits
- 15.209: Radiated Emission Limits; General Requirements

**Guide:** ANSI C63.4:2003

**Test Equipment:** See attached test setup

**Test Configuration of EUT:**

1. The equipment was installed in a typical system and configured in accordance with the manufacturer's instructions. It was also operated in a manner which is representative of the typical usage for the EUT.
2. The equipment and I/O cable(s) were re-arranged to maximize each emission. For each change in configuration, the system was rotated through 360°. The antenna height was changed from one to six meters. Both horizontal and vertical polarization scans were used. The worst case is here reported.
3. For EUTs normally operated on top of a table, tests were performed with the EUT on a rotating non-conducting table top of size 1.0 by 1.5 meters, approximately 1.0 meter above the ground plane.
4. EUTs normally placed on the floor, tests were performed with the EUT on a rotating non-conducting platform, approximately 15 cm above the ground plane.

**Test Procedure:**

1. For AC powered equipment, the EUT was connected to the Public Utility Power Line through a Line Impedance Stabilization Network (LISN), (50  $\mu$ H).
2. The test configuration consisted of the aforementioned equipment and peripherals, using ANSI C63.4:2003.
3. Radiation emission tests were performed on all possible combinations.
4. Measurements were made with the EUT:
  - A. POWERED ON and awaiting data input/output (quiescent mode)
  - B. Receiving/sending data in a typical operation.
5. Each emission was maximized by varying the mode of operation, where applicable.

**Name of Test:** Radiated Spurious Emissions (Continued)

Measurement distance, Meter = 3  
 Height above ground, Meters = 0.8  
 Spectrum searched = Per 47 CFR 15.33  
 Resolution bandwidth, kHz = 120  
 Worst case = Vertical  
 System sensitivity, dBm = -130  
 Search antennas = See Test Setup  
 Post detector video filters used = Indicated BY "Q.P."

All measurements were performed manually using:

- a. HP 85685A, option K40, Sunol turntable with HPIB controls.
- b. HP 85685A, option K42, (EMCO #1053) antenna positioning tower with pneumatic and HPIB controls.

**Sample Calculation:**

$$\begin{aligned} \text{Emission Frequency, MHz} &= \\ \text{Level} &= \text{Log}_{10}^{-1} \left( \frac{26.4 + 17.23}{20} \right) \\ \text{Level, } \mu\text{V/m @ 3m} &= \end{aligned}$$

**Test Setup:** Attached

**Photographs:** Attached

**Results:** Attached



Performed By: Lance Reid, Sr. Test Technician



**Name of Test:** Radiated Emissions (Continued)

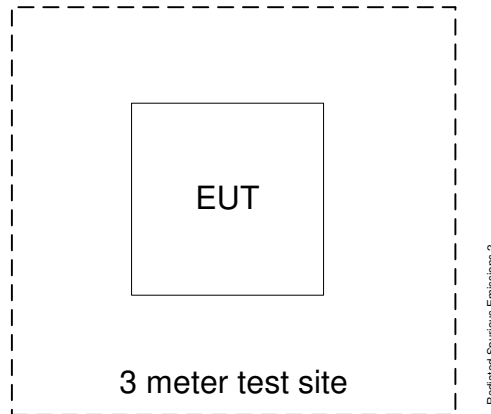

**Notes:**

1. The Equipment Under Test (EUT) and its associated support equipment and I/O Cable(s), if used, were located 3 meters from the search antenna and placed on a conductive ground plane.

### Radiated Test Setup

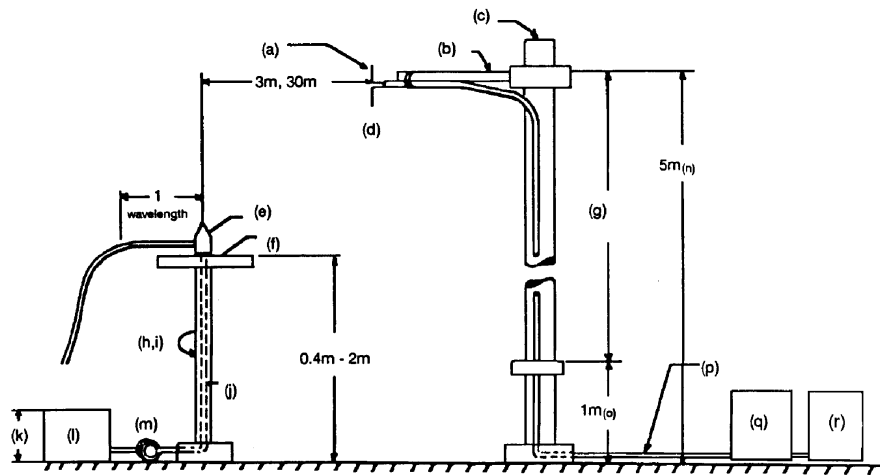

**Notes:**

- (a) Search Antenna - Rotatable on boom
- (b) Non-metallic boom
- (c) Non-metallic mast
- (d) Adjustable horizontally
- (e) Equipment Under Test
- (f) Turntable
- (g) Boom adjustable in height.
- (h) External control cables routed horizontally at least one wavelength.
- (i) Rotatable
- (j) Cables routed through hollow turntable center
- (k) 30 cm or less
- (l) External power source
- (m) 10 cm diameter coil of excess cable
- (n) 25 cm (V), 1 m-7 m (V, H)
- (o) 25 cm from bottom end of 'V', 1m normally
- (p) Calibrated Cable at least 10m in length
- (q) Amplifier (optional)
- (r) Spectrum Analyzer

### Test equipment used

Description	MFG	Model Number	FTL Asset Number	Last Cal Date	Cal Due Date
Bi-conical Antenna	EMCO	3109B	i00088	10/14/05	10/14/07
Log Periodic Antenna	Apriel	2001	i00089	10/20/05	10/20/07
Horn Antenna	EMCO	3115	i00103	9/5/06	9/5/07
Spectrum Analyzer	HP	8566B	i00329	4/16/07	4/16/08

Test Setup:

Radiated Emissions

State:



**Name of Test:** Field Strength of Spurious Radiation  
 g0790013: 2007-Sep-11 Tue 15:29:00  
 State: 1:Hi Power

Frequency Tuned, MHz	Frequency Emission, MHz	Meter, dBuV	CF, dB	uV/m @ 3m	Margin, dB
914.300000	914.280000	48.2	26.82	5636.38	-19.0
914.300000	1828.764000	19.7	30.87	337.68	-3.4
914.300000	2743.044000	12.5	34.5	223.87	-7.0
914.300000	3657.324000	12.2	36.37	268.23	-5.4
914.300000	4571.604000	12.2	37.76	314.77	-4.0
914.300000	5485.884000	9.4	40.39	308.67	-4.2

All other emissions were more than 20db from the limit.

**Name of Test:** Radiated Spurious Emissions (Non-Harmonic)

**Specification:** 47 CFR 15.249(c)

**Guide:** ANSI/TIA/EIA-603-1992, Paragraph 2.2.1

**Test Equipment:** As per previous page

**15.249(c):** Emissions radiated outside of the specified frequency bands, except for harmonics, shall be attenuated by at least 50 dB below the level of the fundamental or to the general radiated emissions limits in § 15.209, whichever is the lesser attenuation.

**General Radiated Emission Limits Per 15.209:**

---

Frequency, MHz	Field Strength, $\mu\text{V}/\text{m}$ @ 3m
30 – 88	100
88 – 216	150
216 – 960	200
Above 960	300

Measurement Results: Attached

**Measurement Results:** Radiated Spurious Emissions (Non-Harmonic)

Frequency of Carrier, MHz	=
Spectrum Searched	= 0 to $10 \times F_C$
All Other Emissions	= $\geq 20$ dB Below Limit
Limit, $\mu V / m @ 3m$	= 50 dBc or § 15.209

All Spurious Emissions Were 20 dB or More Below Limit

System Sensitivity IS -130 dBm

All Non-Harmonic Spurious Emissions Were, -130 dBm

Performed By:

  
Lance Reid, Sr. Test Technician

**Name of Test:** A/C Powerline Conducted Emissions  
**Specification:** FCC: 47 CFR 15.27  
**Guide:** IEEE Standard 213  
**Test Conditions:** S. T. & H.  
**Test Equipment:** As per attached page

#### Measurement Procedure

1. A test sample was connected to the Public Utility lines through a LISN Ailtech Model 94641-1 (50  $\mu$ H).
2. A reference level of 250  $\mu$ V was set on the Spectrum Analyzer. The spectrum was searched over the range of 450 kHz to 30 MHz.
3. All other emissions were 20 dB or more below limit.
4.  The test sample used a AC/DC Plug in Transformer.  
 The test sample does not use a charger.
5. Measurement Results: Attached.

Name of Test: A/C Powerline Conducted Emissions

State:

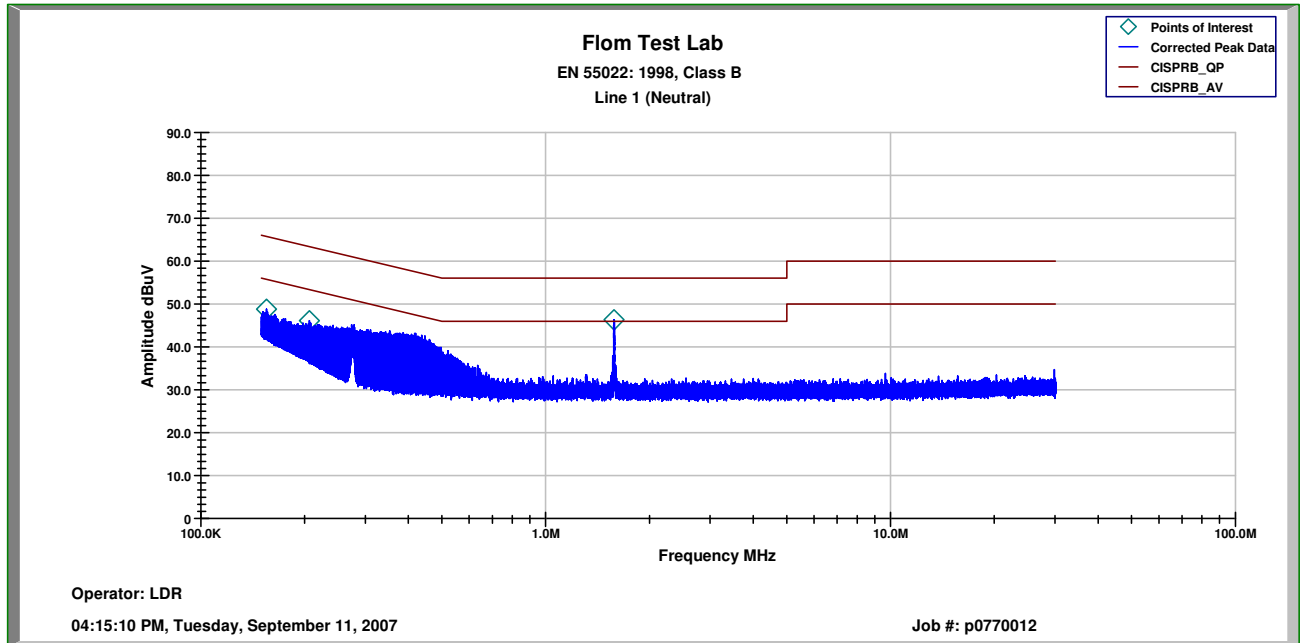

State: Line 1 average

Frequency Emission, MHz	Level dB $\mu$ V	Correction Factor Cable	Correction Factor LISN	Attenuator	Corrected Reading dB $\mu$ V	Limit	Margin
1.5852 MHz	20.97	0	0.19	10	31.16	46	-14.84
198.35 KHz	30.39	0.2	0.04	10	40.63	54.62	-13.99
151.17 KHz	31.83	0.29	0.02	10	42.14	55.97	-13.82

Note: Peak emissions did not exceed the Quasi peak limit.



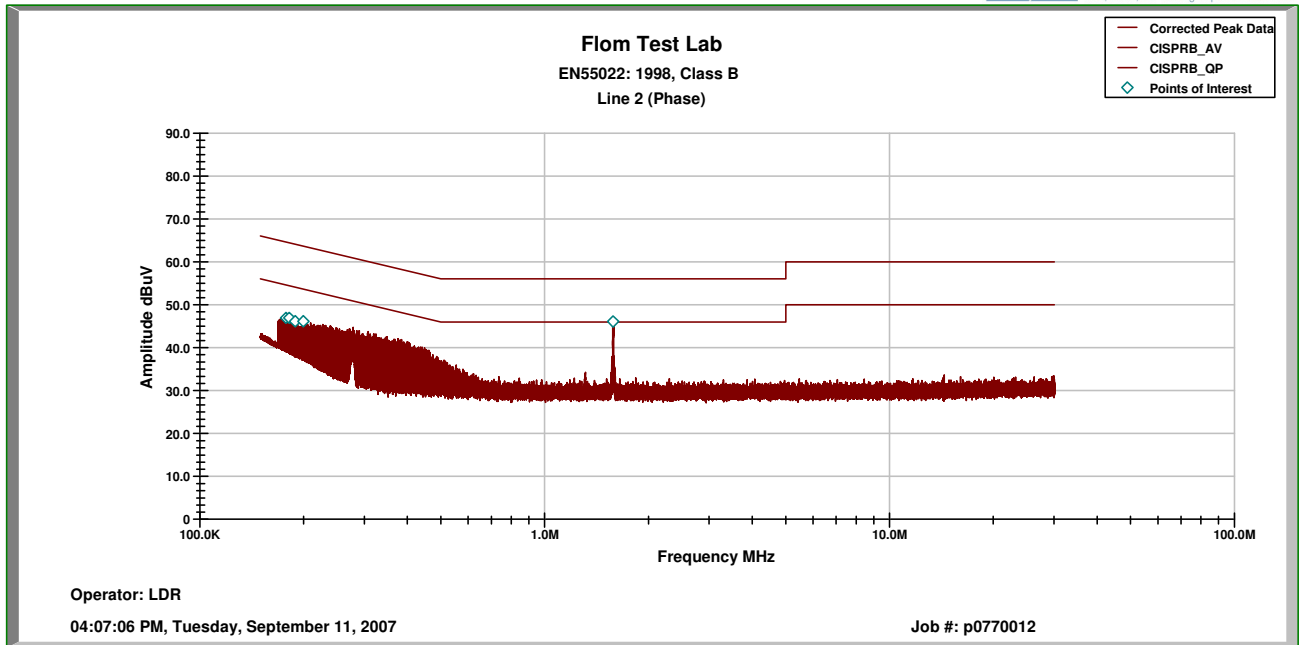

State: Line 1 average

Frequency Emission,	Level dB $\mu$ V	Correction Factor Cable dB	Correction Factor LISN dB	Attenuator dB	Corrected Reading dB $\mu$ V	Limit dB	Margin dB
1.5622 MHz	20.72	0	0.19	10	30.91	46.0	-15.09
195.05 KHz	31.81	0.2	0.04	10	42.05	54.71	-12.66
181.4 KHz	31.6	0.2	0.03	10	41.83	55.1	-13.27
176.11 KHz	30.78	0.2	0.03	10	41.01	55.25	-14.24
165.22 KHz	33.99	0.2	0.03	10	44.22	55.57	-11.35

Note: Peak emissions did not exceed the Quasi peak limit.

Test equipment asset ID: i00155, i00048

Performed By:

*Lance Reid*  
Lance Reid, NCT  
Sr. Test Technician

**Test Setup:**

**Conducted Emissions**

State:



## Radiated Measurements For Part 15 Transmitters with Integral Antennas

### Radiated Measurements

Range Of Measurement	Specification	Resolution B/W	Video B/A
30 to 1000 MHz	CISPR	≥100 kHz	≥100 kHz
>1000 MHz (if averaging)	FCC, 15.37(b)	1 MHz	≥1 MHz
	FCC, 15.37(b)	1 MHz	10 Hz

### Measuring Equipment

**a. Antennas:**

EMCO 3109	20 - 300 MHz
APREL AALP2001	200 - 1000 MHz
APREL AAB20200	20 - 200 MHz
APREL AAH118	1 - 18 GHz

**b. Instruments:**

HP8566B	Spectrum Analyzer
HP85685A	Preselector, w/ preamp below 2 GHz
HP85650A	Quasi Peak Adapter
HP8449	Preamp, above 2 GHz

### Part 15.21, Information to User

The users manual or instruction manual for an intentional or unintentional radiator shall caution the user that changes or modifications not expressly avoided by the party responsible for compliance could void the user's authority to operate the equipment.

§ 15.205 Restricted Bands of Operation

(a) Except as shown in paragraph (b) of this section, only spurious emissions are permitted in any of the frequency bands listed below:

MHz	MHz	MHz	GHz
0.090-0.110	16.42-16.423	399.9-410	4.5-5.25
0.495-0.505	16.69475-16.69625	608-614	5.35-5.46
2.1735-2.1905	16.80425-16.80475	960-1240	7.25-7.75
4.125-4.128	25.5-25.67	1300-1427	8.025-8.5
4.17725-4.17775	37.5-38.25	1435-1626.5	9.0-9.2
4.20725-4.20775	73-74.6	1645.5-1646.5	9.3-9.5
6.215-6.218	74.8-75.2	1660-1710	10.6-12.7
6.26775-6.26825	108-121.94	1718.8-1722.2	13.25-13.4
6.31175-6.31225	123-138	2200-2300	14.47-14.5
8.291-8.294	149.9-150.05	2310-2390	15.35-16.2
8.362-8.366	156.52475-156.52525	2483.5-2500	17.7-21.4
8.37625-8.38675	156.7-156.9	2655-2900	22.01-23.12
8.41425-8.41475	162.0125-167.17	3260-3267	23.6-24.0
12.29-12.293	167.72-173.2	3332-3339	31.2-31.8
12.51975-12.52025	240-285	3345.8-3358	36.43-36.5
12.57675-12.57725	322-339.4	3600-4400	(2)
13.36-13.41			

Until February 1, 1999, this restricted band shall be 0.490-0.510 MHz. Above 38.6

**Testimonial  
and  
Statement of Certification**

**This is to certify that:**

1. **That** the application was prepared either by, or under the direct supervision of, the undersigned.
2. **That** the technical data supplied with the application was taken under my direction and supervision.
3. **That** the data was obtained on representative units, randomly selected.
4. **That**, to the best of my knowledge and belief, the facts set forth in the application and accompanying technical data are true and correct.

Certifying Engineer:

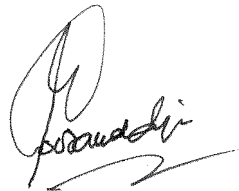

Hoosamuddin S. Bandukwala, Lab Director