



M. Flom Associates, Inc. - Global Compliance Center

3356 North San Marcos Place, Suite 107, Chandler, Arizona 85225-7176

www.mflom.com info@mflom.com (480) 926-3100, FAX: 926-3598

Date: September 8, 2004

Federal Communications Commission
Via: Electronic Filing

Attention: Authorization & Evaluation Division

Applicant: International Electronics Inc
Equipment: The Reporter Voice
FCC ID: JLFPIR2
FCC Rules: 2, 15.249

Gentlemen:

On behalf of the Applicant, enclosed please find Application Form 731, Engineering Test Report and all pertinent documentation, the whole for approval of the referenced equipment as shown.

Filing fees are attached.

We trust the same is in order. Should you need any further information, kindly contact the writer who is authorized to act as agent.

Sincerely yours,

A handwritten signature in black ink, appearing to read "Michael Schafer", with a long horizontal flourish extending to the right.

Michael Schafer,
Business Director

enclosure(s)
cc: Applicant
MS/del

List Of Exhibits
(FCC **Certification** (Transmitters) - Revised 9/28/98)

Applicant: International Electronics Inc

FCC ID: JLFPIR2

By Applicant:

1. Letter Of Authorization
2. Identification Drawings
 - Label
 - Location of Label
 - Compliance Statement
 - Location of Compliance Statement
3. Documentation: 2.1033(B)
 - (3) User Manual
 - (4) Operational Description
 - (5) Block Diagram
 - (5) Schematic Diagram
 - (7) Photographs
 - Block Diagram
 - Parts List
 - Active Devices
4. Draft Specification Information

By M.F.A. Inc.

- A. Testimonial & Statement of Certification



M. Flom Associates, Inc. - Global Compliance Center
3356 North San Marcos Place, Suite 107, Chandler, Arizona 85225-7176
www.mflom.com info@mflom.com (480) 926-3100, FAX: 926-3598

Transmitter Certification

of

Model: The Reporter Voice
FCCID: JLFPIR2

to

Federal Communications Commission

Rule Part(s) 2. 15.249

Date Of Report: September 8, 2004

On the Behalf of the Applicant:

International Electronics, Inc.

At the Request of:

P.O.12422

International Electronics, Inc.
5913-C NE 127th Avenue, Suite#800
Vancouver, WA 98682, USA

Attention of:

Shary Nissimi

Supervised By:

David E. Lee,
Compliance Test Manager

The Applicant has been cautioned as to the following:

15.21 Information to User.

The users manual or instruction manual for an intentional radiator shall caution the user that changes or modifications not expressly approved by the party responsible for compliance could void the user's authority to operate the equipment.

15.27(a) Special Accessories.

Equipment marketed to a consumer must be capable of complying with the necessary regulations in the configuration in which the equipment is marketed. Where special accessories, such as shielded cables and/or special connectors are required to enable an unintentional or intentional radiator to comply with the emission limits in this part, the equipment must be marketed with, i.e. shipped and sold with, those special accessories. However, in lieu of shipping or packaging the special accessories with the unintentional or intentional radiator, the responsible party may employ other methods of ensuring that the special accessories are provided to the consumer, without additional charge.

Information detailing any alternative method used to supply the special accessories for a grant of equipment authorization or retained in the verification records, as appropriate. The party responsible for the equipment, as detailed in § 2.909 of this chapter, shall ensure that these special accessories are provided with the equipment. The instruction manual for such devices shall include appropriate instructions on the first page of text concerned with the installation of the device that these special accessories must be used with the device. It is the responsibility of the user to use the needed special accessories supplied with the equipment.

Table Of Contents

Rule	Description	Page
	Test Report	1
2.1033(c)	General Information Required	2
	Standard Test Conditions and Engineering Practices	6
2.1053(a)	Field Strength of Spurious Radiation	7
15.249(a)	Maximum Radiated Field Strength	12
15.249(c)	Radiated Spurious Emissions (Non-Harmonic)	14
2.1049(c)(1)	Emission Masks (Occupied Bandwidth)	15

Page Number 1 of 18.

Required information per ISO/IEC Guide 25-1990, paragraph 13.2:

- a) **Test Report**
- b) Laboratory: M. Flom Associates, Inc.
(FCC: 31040/SIT) 3356 N. San Marcos Place, Suite 107
(Canada: IC 2044) Chandler, AZ 85225
- c) Report Number: d0490022
- d) Client: International Electronics Inc
- e) Identification: The Reporter Voice System
Description: Passive Infra Red Sensor 2
- f) EUT Condition: Not required unless specified in individual tests.
- g) Report Date: August 27, 2004
EUT Received: July 30, 2004
- h, j, k): As indicated in individual tests.
- i) Sampling method: No sampling procedure used.
- l) Uncertainty: In accordance with MFA internal quality manual.
- m) Supervised by: 
David E. Lee,
Compliance Test Manager
- n) Results: The results presented in this report relate only to the item tested.
- o) Reproduction: This report must not be reproduced, except in full, without written permission from this laboratory.

Page Number 2 of 18.

List Of General Information Required For Certification

In Accordance with FCC Rules and Regulations,
Volume II, Part 2 and to 15.249

Sub-Part 2.1033

(c)(1): Name and Address of Applicant:

International Electronics, Inc.
5913-C NE 127th Avenue, Suite#800
Vancouver, WA 98682, USA

Manufacturer:

Applicant

(c)(2): FCC ID: JLFPIR2

Model Number: Passive Infra Red Sensor 2

(c)(3): Instruction Manual(s):

Please See Attached Exhibits

(c)(4): Type of Emission: ASK

(c)(5): FREQUENCY RANGE, MHz: 916.500

(c)(6): Power Rating,: 29.915 mV/m @3m
 Switchable Variable N/A

(c)(7): Maximum Power Rating,: 50 mV/m @ 3m

15.203: Antenna Requirement:

- The antenna is permanently attached to the EUT
 The antenna uses a unique coupling
 The EUT must be professionally installed
 The antenna requirement does not apply

Page Number 3 of 18.

Subpart 2.1033 (continued)

(c)(8): Voltages & Currents in All Elements in Final RF Stage, Including Final Transistor or Solid State Device:

Collector Current, A	=	0.012
Collector Voltage, Vdc	=	3.7
Supply Voltage, Vdc	=	6

(c)(9): **Tune-Up Procedure:**

Please See Attached Exhibits

(c)(10): **Circuit Diagram/Circuit Description:**

Including description of circuitry & devices provided for determining and stabilizing frequency, for suppression of spurious radiation, for limiting modulation and limiting power.

Please See Attached Exhibits

(c)(11): **Label Information:**

Please See Attached Exhibits

(c)(12): **Photographs:**

Please See Attached Exhibits

(c)(13): **Digital Modulation Description:**

Attached Exhibits
 N/A

(c)(14): **Test and Measurement Data:**

Follows



A2LA

"A2LA has accredited M. Flom Associates, Inc. Chandler, AZ for technical competence in the field of Electrical Testing. The accreditation covers the specific tests and types of tests listed on the agreed scope of accreditation. This laboratory meets the requirements of ISO/IEC 17025 - 1999 'General Requirements for the Competence of Testing and Calibration Laboratories' and any additional program requirements in the identified field of testing."

Certificate Number: **2152-01**

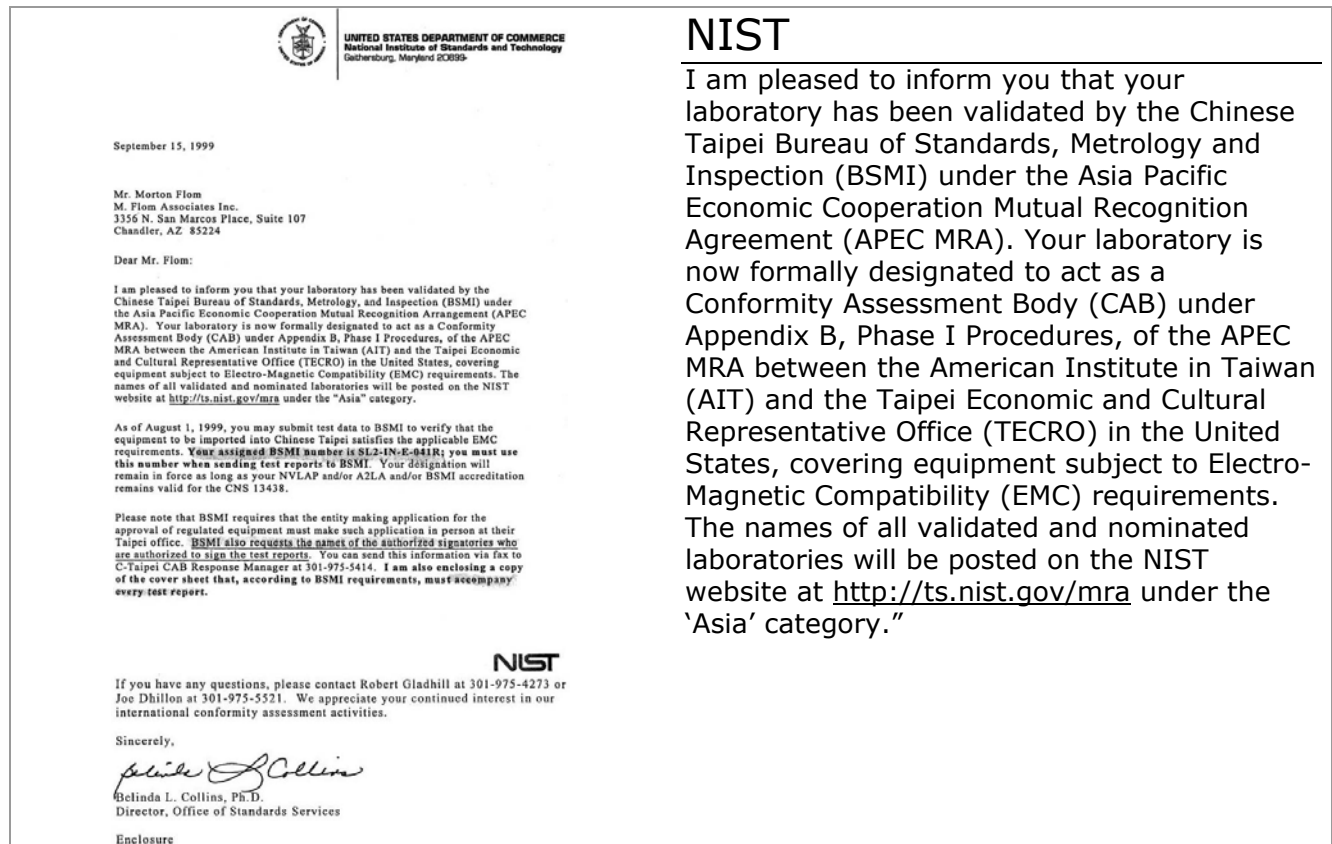

NIST

I am pleased to inform you that your laboratory has been validated by the Chinese Taipei Bureau of Standards, Metrology and Inspection (BSMI) under the Asia Pacific Economic Cooperation Mutual Recognition Agreement (APEC MRA). Your laboratory is now formally designated to act as a Conformity Assessment Body (CAB) under Appendix B, Phase I Procedures, of the APEC MRA between the American Institute in Taiwan (AIT) and the Taipei Economic and Cultural Representative Office (TECRO) in the United States, covering equipment subject to Electro-Magnetic Compatibility (EMC) requirements. The names of all validated and nominated laboratories will be posted on the NIST website at <http://ts.nist.gov/mra> under the 'Asia' category."

Page Number 5 of 18.

Sub-part
2.1033(b):

Test and Measurement Data

All tests and measurement data shown were performed in accordance with FCC Rules and Regulations, Volume II; Part 2, Sub-part J, Sections 2.1031, 2.1033, 2.1035, 2.1041, 2.1043, 2.1045, and the following individual Parts:

_____	15.209	Radiated emission limits; general requirements
_____	15.211	Tunnel radio systems
_____	15.213	Cable locating equipment
_____	15.214	Cordless telephones
_____	15.217	Operation in the band 160-190 kHz
_____	15.219	Operation in the band 510-1705 kHz
_____	15.221	Operation in the band 525-1705 kHz (leaky coax)
_____	15.223	Operation in the band 1.705-10 MHz
_____	15.225	Operation in the band 13.553-13.567 MHz
_____	15.227	Operation in the band 26-27.28 MHz (remote control)
_____	15.229	Operation in the band 40.66-40.70 MHz
_____	15.231	Periodic operation in the band 40.66-40.70 MHz and above 70 MHz
_____	15.233	Operation within the bands 43.71-44.49, 46.60-46.98 MHz 48.75-49.51 MHz and 49.66-50.0 MHz
_____	15.235	Operation within the band 49.82-49.90 MHz
_____	15.237	Operation within the bands 72.0-73.0 MHz, 74.6-74.8 MHz and 75.2-76.0 MHz (auditory assistance)
_____	15.239	Operation in band 88-108 MHz
_____	15.241	Operation in the band 174-216 MHz (biomedical)
_____	15.243	Operation in the band 890-940 MHz (materials)
_____	15.245	Operation within the bands 902-928 MHz, 2435-2465 MHz, 5785-5815 MHz, 10500-10550 MHz, and 24075-24175 MHz (filed disturbance sensors)
_____	15.247	Operation within bands 902-928 MHz, 2400-2483.5 MHz, and 5725-5850 MHz (spread spectrum)
X	15.249	Operation within the bands 902-928 MHz, 2400-2483.5 MHz, 5725-5875 MHz, and 24.0-24.25 GHz
_____	15.251	Operation within the bands 2.9-3.26 GHz, 3.267-3.332 GHz, 3.339-3.3458 GHz, and 3.358-3.6 GHz (vehicle identification systems)
_____	15.321	Specific requirements for asynchronous devices operating in the 1910-1920 MHz and 2390-2400 MHz bands (Unlicensed PCS)
_____	15.323	Specific requirements for isochronous devices operating in the 1920-1930 MHz sub-band (Unlicensed PCS)

Page Number

6 of 18.

Standard Test Conditions
And
Engineering Practices

Except as noted herein, the following conditions and procedures were observed during the testing:

In accordance with ANSIC63.4-1992/2001, section 6.1.9, and unless otherwise indicated in the specific measurement results, the ambient temperature of the actual EUT was maintained within the range of 10° to 40°C (50° to 104 °F) unless the particular equipment requirements specify testing over a different temperature range. Also, unless otherwise indicated, the humidity levels were in the range of 10% to 90% relative humidity.

Prior to testing, the EUT was tuned up in accordance with the manufacturer's alignment procedures. All external gain controls were maintained at the position of maximum and/or optimum gain throughout the testing.

Measurement results, unless otherwise noted, are worst-case measurements.

Page Number 7 of 18.

Name of Test: Field Strength of Spurious Radiation

Specification: 47 CFR 2.1053(a)

Guide: ANSI/TIA/EIA-603-1992/2001, Paragraph 1.2.12 and Table 16, 47 CFR 22.917

Measurement Procedure

1.2.12.1 Definition: Radiated spurious emissions are emissions from the equipment when transmitting into a non-radiating load on a frequency or frequencies which are outside an occupied band sufficient to ensure transmission of information of required quality for the class of communications desired.

1.2.12.2 Method of Measurement

- A) Connect the equipment as illustrated
- B) Adjust the spectrum analyzer for the following settings:
 - 1) Resolution Bandwidth 100 kHz (<1 GHz), 1 MHz (> 1GHz).
 - 2) Video Bandwidth \geq 3 times Resolution Bandwidth, or 30 kHz (22.917)
 - 3) Sweep Speed \leq 2000 Hz/second
 - 4) Detector Mode = Mean or Average Power
- C) Place the transmitter to be tested on the turntable in the standard test site. The transmitter is transmitting into a non-radiating load which is placed on the turntable. The RF cable to this load should be of minimum length.

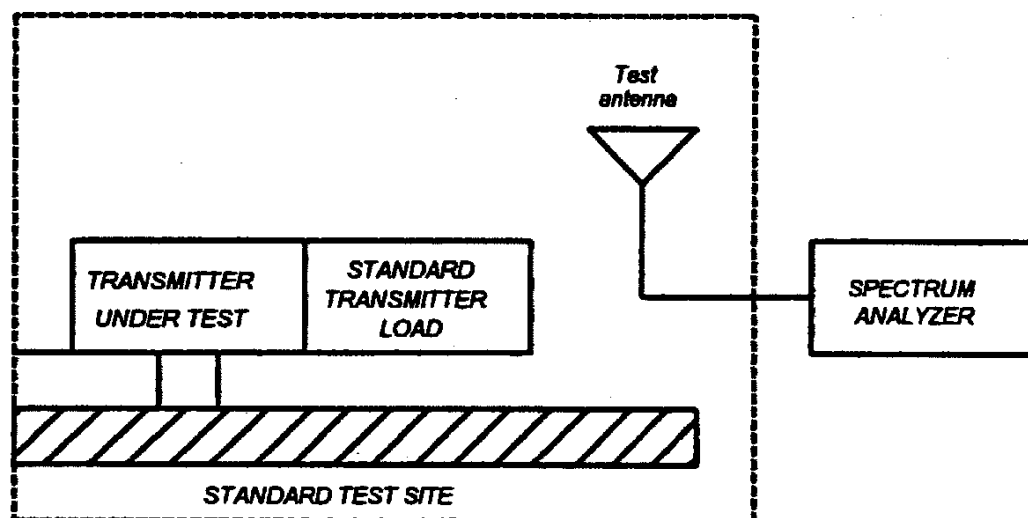

Page Number 8 of 18.

Name of Test: Field Strength of Spurious Radiation (Cont.)

- D) For each spurious measurement the test antenna should be adjusted to the correct length for the frequency involved. This length may be determined from a calibration ruler supplied with the equipment. Measurements shall be made from the lowest radio frequency generated in the equipment to the tenth harmonic of the carrier, except for the region close to the carrier equal to \pm the test bandwidth (see section 1.3.4.4).
- E) For each spurious frequency, raise and lower the test antenna from 1 m to 4 m to obtain a maximum reading on the spectrum analyzer with the test antenna at horizontal polarity. Repeat this procedure to obtain the highest possible reading. Record this maximum reading.
- F) Repeat step E) for each spurious frequency with the test antenna polarized vertically.

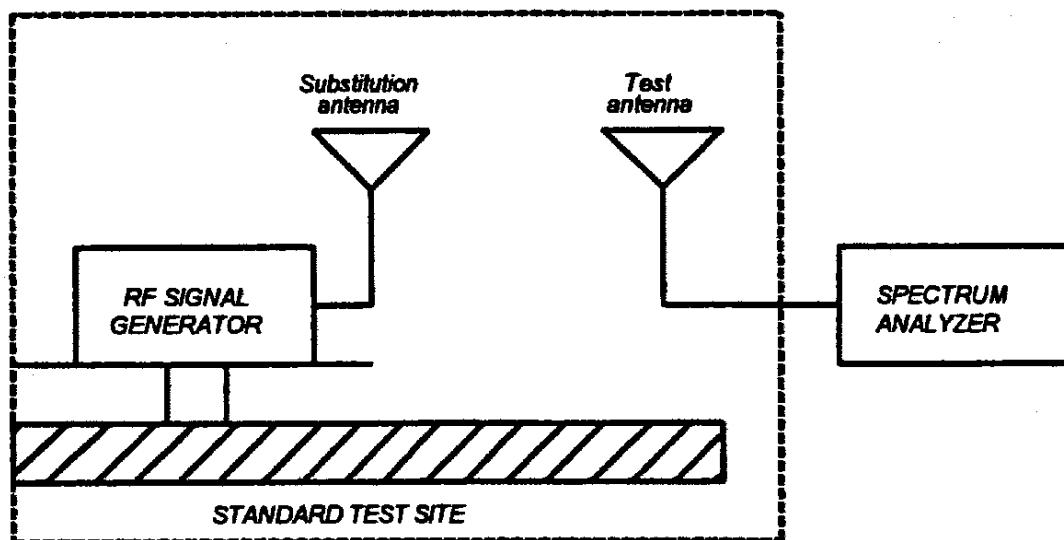

- G) Reconnect the equipment as illustrated.
- H) Keep the spectrum analyzer adjusted as in step B).
- I) Remove the transmitter and replace it with a substitution antenna (the antenna should be half-wavelength for each frequency involved). The center of the substitution antenna should be approximately at the same location as the center of the transmitter. At lower frequencies, where the substitution antenna is very long, this will be impossible to achieve when the antenna is polarized vertically. In such case the lower end of the antenna should be 0.3 m above the ground.

Page Number 9 of 18.

Name of Test: Field Strength of Spurious Radiation (Cont.)

- J) Feed the substitution antenna at the transmitter end with a signal generator connected to the antenna by means of a non-radiating cable. With the antennas at both ends horizontally polarized and with the signal generator tuned to a particular spurious frequency, raise and lower the test antenna to obtain a maximum reading at the spectrum analyzer. Adjust the level of the signal generator output until the previously recorded maximum reading for this set of conditions is obtained. This should be done carefully repeating the adjustment of the test antenna and generator output.
- K) Repeat step J) with both antennas vertically polarized for each spurious frequency.
- L) Calculate power in dBm into a reference ideal half-wave dipole antenna by reducing the readings obtained in steps J) and K) by the power loss in the cable between the generator and the antenna and further corrected for the gain of the substitution antenna used relative to an ideal half-wave dipole antenna.
- M) The levels recorded in step L) are absolute levels of radiated spurious emissions in dBm. The radiated spurious emissions in dB can be calculated by the following:

Radiated spurious emissions dB =
 $10\log_{10}(\text{TX power in watts}/0.001) - \text{the levels in step l)}$

NOTE: It is permissible that other antennas provided can be referenced to a dipole.

Test Equipment:

Asset (as applicable)	Description	s/n	Cycle	Last Cal
Transducer				
i00088	EMCO 3109-B 25MHz-300MHz	2336	24 mo.	Sep-03
i00065	EMCO 3301-B Active Monopole	2635	24 mo.	Sep-03
X i00089	Apral 2001 200MHz-1GHz	001500	24 mo.	Sep-03
X i00103	EMCO 3115 1GHz-18GHz	9208-3925	24 mo.	Sep-03
Amplifier				
X i00028	HP 8449A	2749A00121	12 mo.	Mar-04
Spectrum Analyzer				
i00029	HP 8563E	3213A00104	12 mo.	Mar-04
X i00033	HP 85462A	3625A00357	12 mo.	Sep-03

Page Number

10 of 18.

Test Setup:

Radiated Emissions

State:



Page Number 11 of 18.

Name of Test: Field Strength of Spurious Radiation
g0480110: 2004-Aug-20 Fri 15:36:00
State: 2:High Power

Frequency Tuned, MHz	Frequency Emission, MHz	Meter, dBuV	CF, dB	uV/m @ 3m
916.500000	1833.254000	12.94	43.05	350.13
916.500000	2749.838000	12.93	44.18	365.54
916.500000	3666.396667	29.00	12.7	121.62
916.500000	4582.996667	31.17	15.17	207.49
916.500000	5499.596667	29.17	15.26	166.53
916.500000	6416.196667	28.50	16.55	178.85
916.500000	7332.796667	31.17	17.87	283.14
916.500000	8249.396667	32.17	20.65	437.52
916.500000	9165.996667	29.33	18.59	248.89

Page Number 12 of 18.
Name of Test: Maximum Radiated Field Strength
Specification: 47 CFR 15.249(a)
Spec. Limit: 50 mV/m @ 3m

Radiated Test Setup

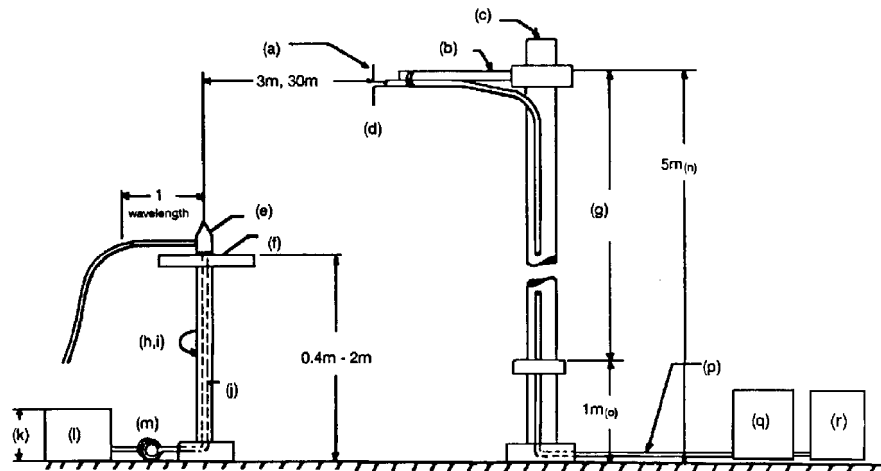

NOTES:

- (a) Search Antenna - Rotatable on boom
- (b) Non-metallic boom
- (c) Non-metallic mast
- (d) Adjustable horizontally
- (e) Equipment Under Test
- (f) Turntable
- (g) Boom adjustable in height.
- (h) External control cables routed horizontally at least one wavelength.
- (i) Rotatable
- (j) Cables routed through hollow turntable center
- (k) 30 cm or less
- (l) External power source
- (m) 10 cm diameter coil of excess cable
- (n) 25 cm (V), 1 m-7 m (V, H)
- (o) 25 cm from bottom end of 'V', 1m normally
- (p) Calibrated Cable at least 10m in length
- (q) Amplifier (optional)
- (r) Spectrum Analyzer

Asset	Description	s/n	Cycle	Last Cal
Transducer				
X	i00088	EMCO 3109-B 25MHz-300MHz	2336	24 mo. Sep-03
X	i00089	April 2001 200MHz-1GHz	001500	24 mo. Sep-03
X	i00103	EMCO 3115 1GHz-18GHz	9208-3925	24 mo. Sep-03
Amplifier				
X	i00028	HP 8449A	2749A00121	12 mo. Mar-04
Spectrum Analyzer				
X	i00029	HP 8563E	3213A00104	12 mo. Jan-04
X	i00033	HP 85462A	3625A00357	12 mo. Sep-03

Page Number 13 of 18.

Measurement Data

g0480109:2004-Aug-20 Fri 14:59:00

Frequency Tuned, MHz	Frequency Emission, MHz	Meter, dBuV	CF, dB	uV/m @ 3m
916.500000	916.497000	54.75	34.68	29,915.65

Supervised By:

David E. Lee,
Compliance Test Engineer

Page Number 14 of 18.

Name of Test: Radiated Spurious Emissions (Non-Harmonic)

Specification: 47 CFR 15.249(c)

Guide: ANSI/TIA/EIA-603-1992/2001, Paragraph 2.2.1

Test Equipment: As per previous page

15.249(c):

Emissions radiated outside of the specified frequency bands, except for harmonics, shall be attenuated by at least 50 dB below the level of the fundamental or to the general radiated emissions limits in § 15.209, whichever is the lesser attenuation.

General Radiated Emission Limits Per 15.209:

Frequency, MHz	Field Strength, $\mu\text{V}/\text{m}$ @ 3m
30 - 88	100
88 - 216	150
216 - 960	200
Above 960	300

Measurement Results:

Frequency of Carrier, MHz = 916.500000
 Spectrum Searched = 0 to $10 \times F_C$
 All Other Emissions = ≥ 20 dB Below Limit
 Limit, $\mu\text{V}/\text{m}$ @ 3m = 50 dBc or § 15.209

All Spurious Emissions were 20 Db or more below limit

System sensitivity -130 dBm



Supervised By:

David E. Lee,
Compliance Test Manager

Page Number 15 of 18.

Name of Test: Emission Masks (Occupied Bandwidth)

Specification: 47 CFR 2.1049(c)(1)

Guide: ANSI/TIA/EIA-603-1992, Paragraph 2.2.11

Test Equipment: As per previous page

Measurement Procedure

1. The EUT and test equipment were set up as shown on the following page, with the Spectrum Analyzer connected.
2. For EUTs supporting audio modulation, the audio signal generator was adjusted to the frequency of maximum response and with output level set for ± 2.5 kHz deviation (or 50% modulation). With level constant, the signal level was increased 16 dB.
3. For EUTs supporting digital modulation, the digital modulation mode was operated to its maximum extent.
4. The Occupied Bandwidth was measured with the Spectrum Analyzer controls set as shown on the test results.
5. Measurement Results: Attached

Page Number

Transmitter Spurious Emission

Test A. Occupied Bandwidth (In-Band Spurious)
 Test B. Out-of-Band Spurious

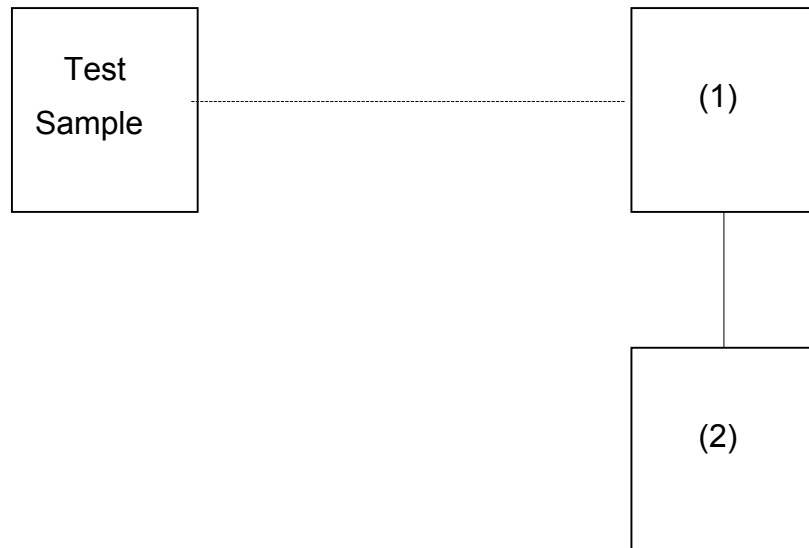

Asset	Description	s/n		
(1)	Antenna – Loose Coupled			
(2)	Spectrum Analyzer			
X	i00029	HP 8563E	3213A00104	12 mo. Jan-04
X	i00033	HP 85462A	3625A00357	12 mo. Sep-03

Page Number 17 of 18.

Name of Test: Emission Masks (Occupied Bandwidth)
g0480120: 2004-Aug-27 Fri 08.22:00
State: 2:High Power

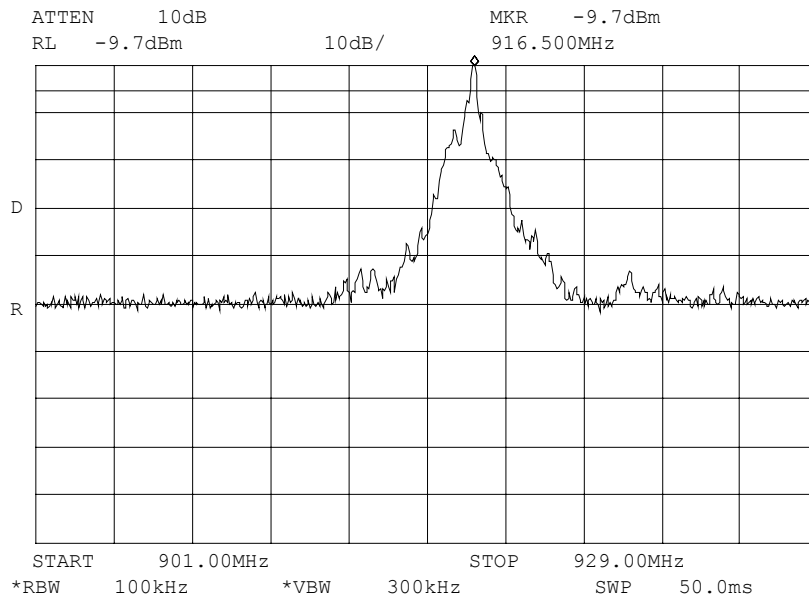

Power:
Modulation:

HIGH (LOOSE COUPLED)
ASK
BAND EDGES

Supervised By:

David E. Lee,
Compliance Test Manager

Page Number 18 of 18.

Name of Test: Emission Masks (Occupied Bandwidth)
Indicating 20 dB Bandwidth

g0480119: 2004-Aug-27 Fri 08:17:00

State: 2:High Power

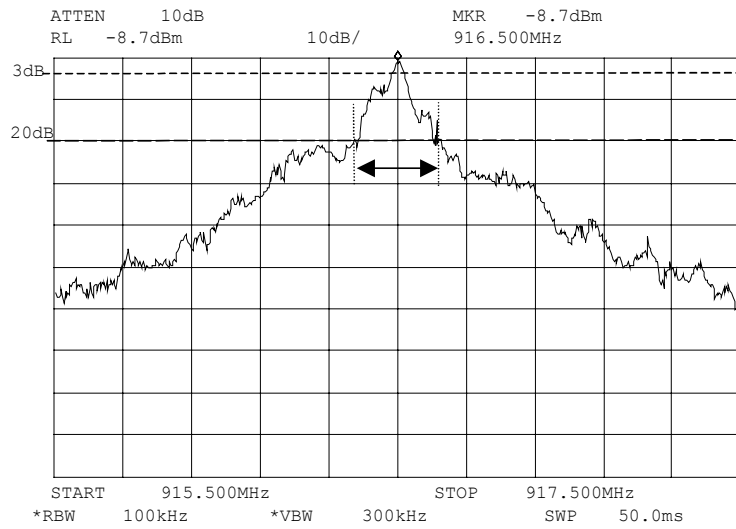

Power:
Modulation:

HIGH (LOOSE COUPLED)
ASK
SIGNAL BAND WIDTH
250kHz @ 20dB

Supervised By:

David E. Lee,
Compliance Test Manager

NOTICE:

§ 15.205 Restricted Bands of Operation

(a) Except as shown in paragraph (b) of this section, only spurious emissions are permitted in any of the frequency bands listed below:

MHz	MHz	MHz	GHz
0.090-0.110	16.42-16.423	399.9-410	4.5-5.25
0.495-0.505	16.69475-16.69625	608-614	5.35-5.46
2.1735-2.1905	16.80425-16.80475	960-1240	7.25-7.75
4.125-4.128	25.5-25.67	1300-1427	8.025-8.5
4.17725-4.17775	37.5-38.25	1435-1626.5	9.0-9.2
4.20725-4.20775	73-74.6	1645.5-1646.5	9.3-9.5
6.215-6.218	74.8-75.2	1660-1710	10.6-12.7
6.26775-6.26825	108-121.94	1718.8-1722.2	13.25-13.4
6.31175-6.31225	123-138	2200-2300	14.47-14.5
8.291-8.294	149.9-150.05	2310-2390	15.35-16.2
8.362-8.366	156.52475-156.52525	2483.5-2500	17.7-21.4
8.37625-8.38675	156.7-156.9	2655-2900	22.01-23.12
8.41425-8.41475	162.0125-167.17	3260-3267	23.6-24.0
12.29-12.293	167.72-173.2	3332-3339	31.2-31.8
12.51975-12.52025	240-285	3345.8-3358	36.43-36.5
12.57675-12.57725	322-339.4	3600-4400	
13.36-13.41			

**Testimonial
and
Statement of Certification**

This is to certify that:

1. **That** the application was prepared either by, or under the direct supervision of, the undersigned.
2. **That** the technical data supplied with the application was taken under my direction and supervision.
3. **That** the data was obtained on representative units, randomly selected.
4. **That,** to the best of my knowledge and belief, the facts set forth in the application and accompanying technical data are true and correct.

Certifying Engineer:



David E. Lee,
Compliance Test Manager