

Oracle limited LIFETIME WARRANTY

International Electronics Inc. (IEI) warrants this product to be free of defects in materials and workmanship, for its usable lifetime. For a period of ONE YEAR following purchase, IEI will repair or replace the product free of charge, including parts, labor, return shipping to you, and handling.

After the initial one year of operation, the limited lifetime warranty will cover parts, labor, and return shipping to you, with a minimal handling charge specific to the product, as listed below:

Gate Access Panel (with Keypad):	\$55.00	Oracle Flush Mount Intercom:	\$20.00
Gate Controller Unit:	\$30.00	Telephone Interface unit:	\$40.00
Key-fob Remote:	\$10.00	Repeater System:	\$40.00
Outdoor Intercom (no keypad):	\$35.00	Oracle Portable Intercom:	\$20.00

INSTALLER: If you have installation questions, please contact your Distributor.

CONSUMER BEFORE INSTALL: If you have questions, please contact your Installer.

CONSUMER AFTER INSTALL: If you have operation questions or are in need of warranty service, please contact our Product Support department by email at techsupp@nwlink.com or call 360-254-1564 Tuesday-Friday 7-5 Pacific Time. If the issue is not resolvable, a manufacturer's warranty repair order may be issued. To have the product(s) sent for warranty service. A Return Authorization number will be issued for warranty service, which must be put on the outside of the package, to be received and handled properly. Packages for warranty service may be sent to the following address. Packages with no RA# may not be accepted.

IEI
5913C NE 127th AVE, Suite 800
Vancouver, WA 98682

Please include a note describing the problem that you are having and a **copy of your original sales receipt** (within the first year). If the warranty service is outside the first year, please include a check made out to IEI, based on the list of handling fees, shown above. Please note that you may need to send multiple units for warranty service, testing, and upgrading, though only the applicable fee for handling the failed unit(s) will be charged.

Please allow 2-4 weeks for service and return shipping. If an EXPEDITED repair/replacement is requested, a 100% surcharge applies. In this case, please write EXPEDITED after the RA number. IEI will attempt to return expedited repair orders within one week, except during holidays.

All repairs or replacements are at the discretion of the Manufacturer. This warranty excludes items that have been abused, altered, incorrectly installed, or repaired by an unauthorized person. Changes or modifications not expressly approved by the Manufacturer could void the user's authority to operate the equipment. The manufacturer is not responsible for any radio or TV interference caused by unauthorized modifications to this equipment. Such modifications could void the user's authority to operate the equipment. This warranty is limited to the product only. No consequential damages are covered.

This device complies with part 15 of the FCC Rules. Operation is subject to the following two conditions:

- (1) This device may not cause harmful interference, and (2) this device must accept any interference received, including interference that may cause undesired operation.

International Electronics, Inc.
FCC ID: JLFOWK5
IC: 2666A-OWK5
Country of Origin: USA

Oracle^(TM) Wireless Keypad

Thank you for purchasing the Oracle Wireless Keypad. This product has been designed and manufactured in the USA, utilizing the highest quality standards available.

**No Wiring or Trenching
Required**



- Controls up to four Gate Openers or other accessories
- Multiple Control Modes
- Proximity Detector with Backlit key-pad after dark
- Echo Confirmation Feedback
- Up to 2 years on 4xAA batteries
- Multiple Power Saving Modes
- Temporary one-time use/24 hour PIN numbers
- Use Several Keypads together in Multi-Keypad Mode
- Use Alternate Channel Groups to overcome interference
- Oracle Wireless Keypad (OWK) has 2 models:
OWK5 – 5 Pin Codes
OWK250 – 250 Pin Codes



International Electronics, Inc.



Made With Pride In the USA.

A manufacturer's Limited Lifetime Warranty covers this product.

TABLE OF CONTENTS

Preface
 General Information.....3
 Parts Supplied.....3

Section 1 – Installation
 1.1 Installing the Oracle Wireless Keypad (OWK).....3
 1.2 Initializing a new Master Pin Number.....3

Section 2 – Gate Control Unit (GCU) Installation
 2.1 Installing the batteries.....4
 2.2 Setting the GCU identity.....4
 2.3 Installing the GCU.....5

Section 3 – Activating The Gate Control Unit (GCU)
 Activating a GCU.....5

Section 4 – General Operation
 Opening a gate.....6

Section 5 – Pin Codes
 5.1 User-level PIN numbers.....6
 5.2 Removing User-level PIN numbers.....6
 5.3 Temporary User PIN numbers.....7
 5.4 Changing the Master PIN number.....7

Section 6 – Oracle Wireless Keypad (OWK) Settings
 6.1 OWK Keypad Brightness.....7
 6.2 Alternate Channel Group.....8

Section 7 – Operating Modes
 7.1 Multi-Keypad (OWK) Mode.....8
 7.2 Multi-Keypad Default GCU Setting.....9
 7.3 Party Mode.....9
 7.4 Vacation Mode.....9
 7.5 Power-Save Mode.....10

Section 8 – Types of Batteries Used
 Batteries.....10

Section 9 – Quick List of Functions
 Quick list of functions.....10

Section 10 – Appendix A
 Detailed GCU Installation Instructions.....11

Section 11 – Frequently Asked Questions and Troubleshooting
 FAQ's and Troubleshooting.....15

FREQUENTLY ASKED QUESTIONS AND TROUBLESHOOTING

Why won't the Wireless Keypad accept a PIN number?

The Wireless Keypad Unit will not learn a PIN # if it is the same number as the factory's reset code.

Why won't my new gate controller work?

Make sure that it was taught to the Wireless Keypad Unit (see **Activating a new Gate Controller**). If you hear a four-beep error tone, the Wireless Keypad Unit did not mate with the Gate Controller. If the Gate Controller is #2, 3, or 4, make sure that the corresponding ID is set with dipswitches 1&2, in the Gate Controller (See **Basic Gate Control Unit Installation**)

I need the Manufacturer's Reset Code; to reset my Wireless Keypad Unit

The **Wireless Keypad Unit's** serial number is printed on the inside of the **Wireless Keypad Unit's** mounting plate. Call our Product Support staff at 888.679.7994, for the reset code. You MUST have the **Wireless Keypad Unit's** serial number handy, to receive the reset code. Simply enter the reset code on the **Wireless Keypad Unit's** keypad and after one minute, the unit will clear its memory and you may re-teach the Keypad System.

Why do I hear a warbling two-tone error sound when I activate a Gate Controller?

The **Wireless Keypad Unit** is not communicating with the GCU. The GCU may be out of range. If the units work properly when close together, the GCU may need to be mounted higher off the ground or on a different surface. Metal, trees, or masonry cause the most interference.

If the units do not work when close together, the **Wireless Keypad Unit** has not mated with that GCU. Double-check the GCU's ID (as set with dipswitches 1 2, and re-teach it.

My Oracle System Network has very short range

Short transmission range is usually related to interference. If there is a conflicting 900-MHz radio transmitter near-by, you may need to have the Oracle **Wireless Keypad Unit** use an alternate group of channels. See: **Alternate Channel Group Selection**.

Stucco: When used in a dwelling with stucco or cement walls, the RF range is reduced greatly. The Oracle Repeater will solve this issue. Place the repeater close to the house to mitigate this problem.

Sample Configuration 3: Open, Close Gate and Verify Gate Status

Use this configuration when you wish to use the Reporter Gate System to open and close your gate and check the gate's actual status, connecting the Gate Controller to a limit switch or external gate status indicator.

Enable or disable the Auto-close feature on your Automatic Gate Opener.

Connect Reporter Gate Controller Contacts 7 and 8 to "Strike Open", "Open Only", "Remote" or a similarly named contact pair on your Automatic Gate Opener. *Please refer to your product-specific manual for wiring information.*

Connect Contact 2 to Ground, COM, or (-) on your Automatic Gate Opener.

Flip Gate Controller Dipswitch #3 to the UP position to enable status checking.

If your Automatic Gate Opener has a "Close" or "Close Only" contact pair (e.g. connecting like a 3-button station), connect Contacts 5 and 6 to the "Close" contacts and flip Gate Controller Dipswitch #5 to the UP position.

If desired, enable Auto-close on the Gate Controller by flipping Gate Controller Dipswitch #6 to the UP position. If you use this feature, disable auto-close on your Automatic Gate Opener.

Connect terminals #3 and #4 across the "Gate Closed" limit switch. Polarity does not matter.

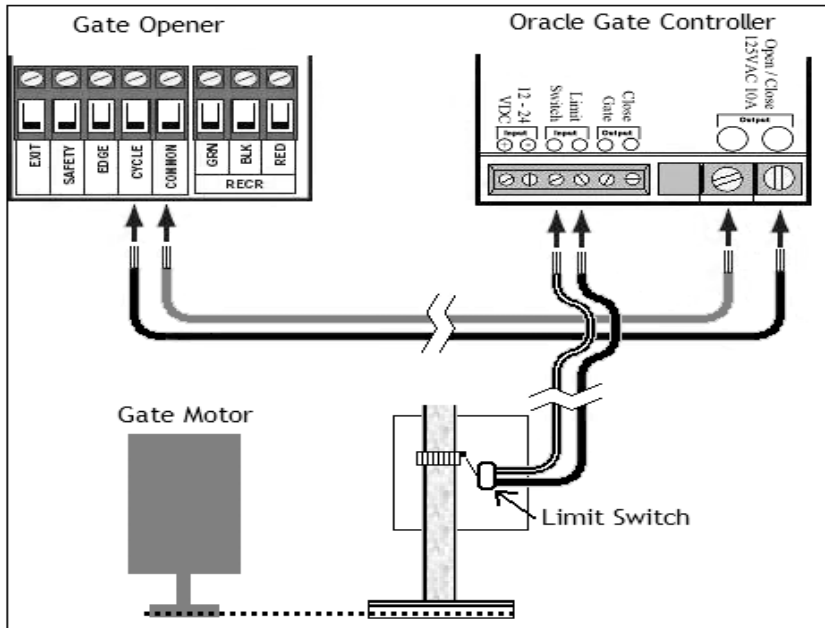

GENERAL INFORMATION

Utilizing Universal's newest wireless protocols, this keypad product line is able to meet and exceed the most stringent security and environmental requirements.

Ultra long Range, Low Power Usage and its Two Way design, which provides Confirmation Feedback of Receiver Action make this system the most robust available.

PARTS SUPPLIED

- 1 - Oracle Wireless Keypad (OWK)
- 1 - OWK Mounting Kit which includes:
 - 4 - 1/4 x 1 Steel Screws
 - 4 - 1/4 Washers
 - 4 - 1/4 Lock Nuts
- 4 - 8-32 X 1 5/8 Black Socket Assembly Screws
- 1 - Hex Key

ORACLE WIRELESS KEYPAD (OWK) INSTALLATION

1.1 INSTALLING THE OWK

The Oracle Wireless Keypad Unit has been designed specifically for easy installation. After determining where you want the Wireless Keypad Unit (OWK) to be mounted, just fasten the back panel to a post or solid surface, using the included OWK mounting kit, making sure that is within easy reach of a visitor.

Place four 'AA' batteries in the OWK's battery pack. You will hear a periodic low-volume beep, indicating that the unit is operational and ready to be programmed with your secure master PIN number. **For longer battery life and better functionality, use lithium 'AA' batteries.**

Install the front of the Wireless Keypad Unit onto the already installed mounting plate, using the included Assembly screws and hex key provided.

1.2 INITIALIZING A NEW MASTER PIN NUMBER

The beeping you hear is the OWK prompting you to enter a new Master Pin Number.

On the Keypad, press: **# # #**

Followed by your four digit Master PIN Number (for example):

1 2 3 4

A tone indicates that the unit has accepted your Master PIN Number.

Note: ***** Is a 'Cancel' button to cancel any call or key sequence.

GATE CONTROL UNIT (GCU) INSTALLATION

2.1 INSTALLING THE BATTERIES

Open the GCU by holding the box/shell portion of the unit. Then, while tilting the bottom section (where the wire is located), pull the box/shell off. Insert 4 'AA' batteries into the exposed battery holder.

Note: If used in locations that will be below -10°C (20°F), Lithium batteries are recommended.

Note: Leave the box/shell off until after activation is complete.

2.2 SETTING THE GATE CONTROLLER IDENTITY

You can use up to 4 GCU's with each OWK utilized. If you use more than 1 GCU, the additional units must have their identity set. Changing dipswitches #1 & #2 on the Gate Control Unit sets the Gate Controller Identity. (See below.)

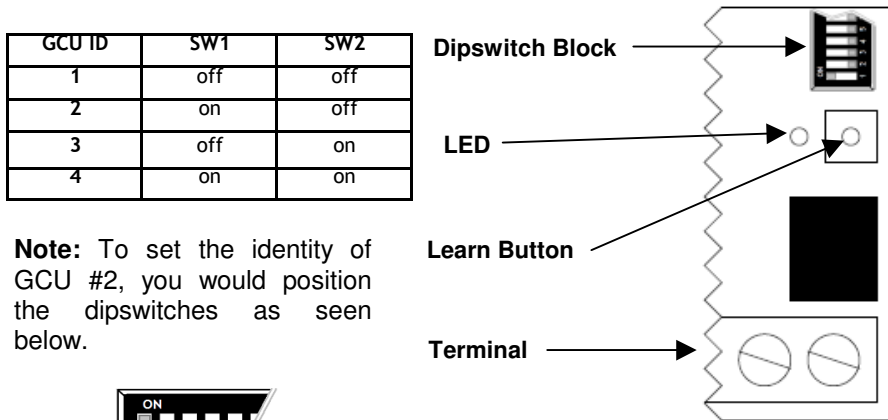

Note: To set the identity of GCU #2, you would position the dipswitches as seen below.

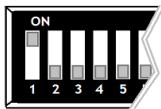

NOTE: IS a Cancel button to cancel any call or key sequence.

Sample Configuration 1:

Open Gate Only

Use this configuration when you wish to use the Reporter Gate System as an open-only system, which automatically closes, based on a timer or a magnetic loop.

Enable the Auto-close feature on your Automatic Gate Opener. Connect the Reporter Gate **Controller as shown in the Basic Gate Controller Installation** diagram. Please refer to your product-specific manual for wiring information. On the Reporter Intercom, disable gate status checking (as described above).

Sample Configuration 2:

Wiring to separate OPEN and CLOSE terminals

Use this configuration when you wish to use the Reporter Gate System to open and close your gate and check the gate's last known status, without connecting to a limit switch or external gate status indicator.

Disable the Auto-close feature on your Automatic Gate Opener.

Connect Contact 2 to Ground, COM, or (-) on your Automatic Gate Opener.

Connect Reporter Gate Controller Contacts 7 and 8 to "Strike Open", "Open Only", "Remote" or a similarly named contact pair on your Automatic Gate Opener. Please refer to your product-specific manual for wiring information.

If your Automatic Gate Opener has a "Close" or "Close Only" contact pair (e.g. connecting like a 3-button station), connect Contacts 5 and 6 to the "Close" contacts.

Slide Gate Controller Dipswitch #5 to the UP position.

If desired, enable Auto-close on the Gate Controller by flipping Gate Controller Dipswitch #6 to the UP position.

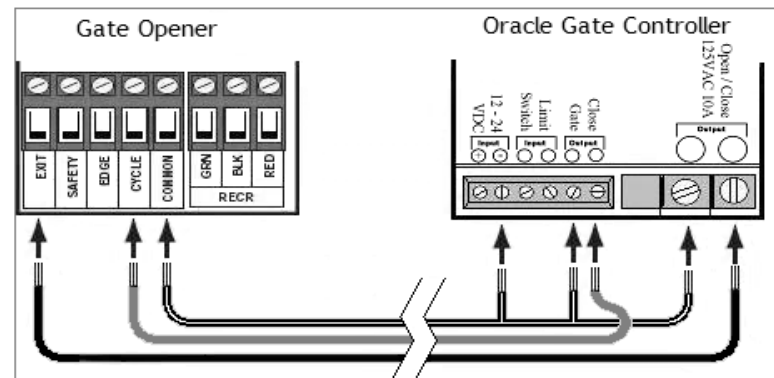

Selecting Gate Controller “ON” Time

For most connections to an Automatic Gate Opener, the default setting of ½ second is best. However, for connection to yard lights, cameras, etc., you may wish to adjust how long the connected device stays on.

Gate Controller “ON” Time	Dipswitch #3	Dipswitch #4
½ second - No Limit Switch	OFF	OFF
½ second - Using a Limit Switch	ON	OFF
10 seconds	OFF	ON
30 seconds	ON	ON

NOTE: For most gate system wiring, dipswitch #4 should be left “OFF.” If you wire your gate controller to a limit switch, dipswitch #3 should be turned “ON”.

Enabling the Auto-Close Feature

By enabling the Auto-Close feature, the Gate Controller will attempt to close the gate 45 seconds after it is opened. This feature will work better if your configuration has at least one of the following elements:

- Separate Open / Close Terminals,
- A “Gate Closed” Sensor or limit switch, or
- A “Gate Open” Sensor or limit switch

Otherwise, the Gate Controller must assume that the gate has not opened or closed for any other device.

Auto-Close Feature	Dipswitch #6
OFF (disabled)	OFF
ON (enabled)	ON

Warning: Please remember safety! Do not enable auto-close where it might pose a risk of entrapment, causing injury, death, or damage to vehicles.

Using Additional Contact / Clearance Sensors

Open/Closed Contact Sensors	Dipswitch #3	Dipswitch#7	Dipswitch#8
No contact sensors used	OFF	OFF	OFF
“Closed” limit switch wired to terminals #3 and #4	ON	OFF	OFF
“Open” limit switch wired to terminals #3 and #4	ON	ON	OFF
Additional “Closed” limit switch or sensor wired to terminals #3 and #4	ON	OFF	ON
Additional “Opened” limit switch or sensor wired to terminals #3 and #4	ON	ON	ON

NOTE: To power an additional contact sensor that is NOT already connected to your gate system, short terminal #3 to ground, connects the switch across terminals 3 and 4, and turn dipswitch #8 ON.

2.3 INSTALLING THE GATE CONTROL UNIT (GCU)

Mount the Oracle Gate Controller near your Automatic Gate Opener’s control panel or motor. Most gate motors have simple relay connections (often labeled **COMMON** and **CYCLE**) that connect to the two large **OPEN/CLOSE** relay outputs on the Oracle Gate Controller.

Note: For more detailed installation information, refer to Appendix A on pg. 15.

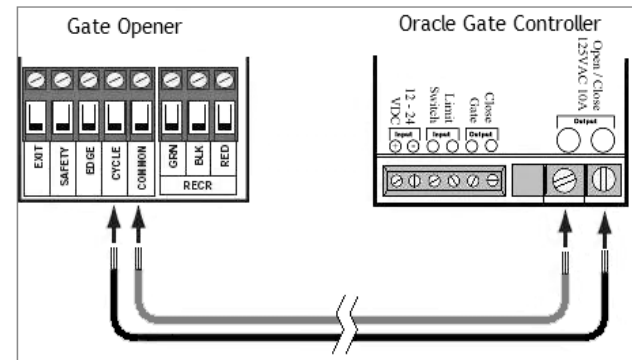

3.0 ACTIVATING A GATE CONTROL UNIT (GCU)

When you are ready to activate the GCU, press the LEARN button on the GCU (see page 4 for location of the LEARN button), for one second. The LED will light up solid for up to 20 seconds.

Within 20 seconds, on the GAP,

Enter your **Master PIN Number** (for example): 1 2 3 4

Followed by the Gate Controller’s Identity: (1 - 4)

The GAP will give a double-beep and the GCU LED will blink 3 short blinks to indicate a successful activation.

Note: If the GAP sounds a 4-beep error tone or the GCU gives 3 double blinks, then check the FAQ section for the possible solution.

If you only have one GCU then you are finished and can proceed to the next step. For additional GCU’s, repeat the process until all GCU’s have been successfully activated.

Note: You can now assemble the GCU by snapping the box/shell back onto the unit.

4.0 OPENING A GATE

To open a gate from the OWK, enter any valid PIN number. With multiple GCU's, enter the PIN number followed by the GCU identity (1-4).

PIN NUMBERS

5.1 USER-LEVEL PIN NUMBERS

The Wireless Keypad can support up to 5 PIN numbers with the OWK5 or up to 250 PIN numbers with the OWK250, for other users.

To add an additional PIN number, on the OWK:

Enter your **Master PIN Number** (for example): **1 2 3 4**

Followed by: **9** "BEEP"

Enter a new PIN number (for example): **4 3 2 1**

To limit the new PIN number to a single GCU, enter the PIN number followed by the GCU identity (1-4), resulting in a five digit PIN number.

The OWK will give a single beep as the new PIN number is accepted.

5.2 REMOVING USER-LEVEL PIN NUMBERS

To remove an additional PIN, on the OWK:

Enter your **Master PIN Number** (for example): **1 2 3 4**

Followed by: **7** "BEEP"

Press: **# # #**

Enter the PIN number you want to remove (for example): **4 3 2 1**

The OWK will give a double beep indicating the PIN has been removed or a triple beep indicating a PIN has been entered that does not exist. The Master PIN cannot be deleted.

APPENDIX A - DETAILED GCU INSTRUCTIONS

Dipswitch Quick Reference
ALL OFF – use only "Open / Close" terminals
3 ON if connecting to a Limit Switch
4 ON if contacts should close for 10 seconds
5 ON if using separate "Close Gate" terminals
6 ON to enable auto-close after 45 seconds
7 ON if connected to **OPEN** limit switch

Tech Support: (360) 254-1564 ext. 290
www.reporterwireless.com Made in USA

Oracle Patents Pending
Gate Controller Unit
 International Electronics, Inc.
 FCC ID: J.LFGCU1
 IC: 3706A-GCU1
 Model: OGCU1
 Country Of Origin: USA

Gate Controller ID Selection

- SW1=OFF & SW2=OFF : Unit ID=#1
- SW1=ON & SW2=OFF : Unit ID=#2
- SW1=OFF & SW2=ON : Unit ID=#3
- SW1=ON & SW2=ON : Unit ID=#4

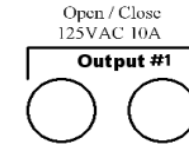
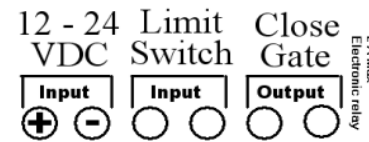

From left to right, Gate Controller Terminals are:

- Optional power input. +9Vto +24VDC. Make sure that your gate's DC power supply "Ground" is wired to terminal 2.
- Ground or Common terminal.
- Limit switch input A. Wire such that when the limit switch is closed, terminal 4 is shorted to terminal 3.
- Limit switch input B. Wire such that when the limit switch is closed, terminal 4 is shorted to terminal 3.
- Secondary Relay Contact A. Up to 120VAC LOW CURRENT contact. Max ½ amp. Typically wired to optional "Close Gate" input on Automatic Gate Opener.
- Secondary Relay Contact B. Up to 120VAC LOW CURRENT contact. Max ½ amp. Typically wired to optional "Close Gate" input on Automatic Gate Opener.
- Primary Relay Contact A. Up to 120VAC. Max 10 amps. Typically wired to "Open Gate", "Open/Close" or "Remote" input on Automatic Gate Opener.
- Primary Relay Contact B. Up to 120VAC. Max 10 amps. Typically wired to "Open Gate", "Open/Close" or "Remote" input on Automatic Gate Opener.



7.5 POWER-SAVE MODE

Power-Save Mode will increase battery life by reducing power consumption and limiting some features. (See NOTE below.) In **Power-Save mode**, the keypad will only light up when a key is pressed.

To enter Power-Save Mode:
Enter the **Master PIN Number** (for example): **1 2 3 4**

Followed by: **0 3**

To exit Power-Save Mode:
Enter the **Master PIN Number** (for example): **1 2 3 4**

Followed by: **0 4**

8.0 BATTERIES

The Gate Controller uses four 'AA' batteries. The average life of the Gate Controller's batteries is a year-and-a-half, depending on use.

The Wireless Keypad Unit uses four 'AA' Alkaline batteries. The average life of the Wireless Keypad Unit's batteries is a year with all functions enabled. Enabling **Power-save Mode** can extend the battery life up to two years.

QUICK LIST OF FUNCTIONS

- | | |
|---|------------------|
| Enable OWK Learn Mode | PIN 05 |
| Add User-Level PIN numbers | PIN 9 PIN |
| Add User-Level PIN numbers w/GCU restrict | PIN 9 PIN (1-4) |
| Add a Temporary PIN number | PIN 51 PIN |
| Add a Temporary PIN number w/GCU restrict | PIN 51 PIN (1-4) |
| Removing PIN numbers | PIN 7 ### PIN |
| Change the Master PIN number | PIN 09 ### PIN |
| OWK Brightness Control | PIN 08 (1-3) |
| Place GAP in Multi-GAP Passive Mode | PIN 56 |
| Default GCU #3 to the Passive OWK | PIN 58 |
| Default GCU #4 to the Passive OWK | PIN 59 |
| Place OWK back to Active Mode | PIN 57 |
| Party Mode | PIN 54 |
| Vacation Mode | PIN 52 |
| Exit Vacation Mode | PIN 53 |
| Power-Save Mode | PIN 03 |
| Exit Power-Save Mode | PIN 04 |
| Alternate Channel Set | PIN 55 (1-3) |

5.3 TEMPORARY USER PIN NUMBER

A temporary PIN number can be issued with an OWK5 (6 for an OWK250), for a 1 time only use, within a 24 hour time period.

To issue a temporary PIN number, on the OWK:
Enter your **Master PIN Number** (for example): **1 2 3 4**

Followed by: **5 1** "BEEP"

Enter the temporary PIN number (for example): **4 3 2 1**

To limit the new PIN number to a single Gate Controller, enter the PIN number followed by the Gate Controller ID (1-4) that it will access, resulting in a five digit PIN number.

The Wireless Keypad Unit will give a single beep as the new PIN Number is accepted.

5.4 CHANGING THE MASTER PIN NUMBER

To change the Master PIN Number, on the OWK:
Enter the existing **Master PIN Number** (for example): **1 2 3 4**

Followed by: **0 9** "BEEP"

Press: **# # #**

Enter the NEW Master PIN Number (for example): **4 3 2 1**

The Wireless Keypad Unit will give a single beep as the new PIN Number is accepted.

ORACLE WIRELESS KEYPAD (OWK) SETTINGS

6.1 OWK KEYPAD BRIGHTNESS

When it is dark out, the Wireless Keypad Unit uses an Infrared proximity sensor to light up the keypad when you come within five feet of it or when a button is pressed. This feature is disabled in Power Save Mode (see **Power-save Mode**).

To brighten or dim, on the OWK:
Enter the **Master PIN Number** (for example): **1 2 3 4**

Followed by: **0 8**

Enter: **1, 2, or 3**

The Wireless Keypad Unit will give a single beep as the new level is accepted. The default level is 2.

6.2 ALTERNATE CHANNEL GROUP SELECTION

The OWK can be set to one of three alternate operating channel groups, to overcome range-reducing interference from conflicting radio transmitters.

To alternate operating channel groups, on the OWK:

Enter the **Master PIN Number** (for example):

Followed by:

Enter:

The Wireless Keypad Unit will give a single beep as the new channel group is accepted. The default setting is channel group 1.

OPERATING MODES

7.1 MULTI-KEYPAD (OWK) MODE

A Wireless Keypad Unit (OWK) can be set to Passive Mode, to work with multiple Wireless Keypad Units (at a second entrance for example). The Passive OWK will become an accessory to the Active OWK.

Note: Both steps 1 & 2 must occur within 2 minutes of each other.

1. On the OWK to be set to Passive:

Enter the **Master PIN Number** (for example):

Followed by:

2. On the OWK to be set to Active:

Enter the **Master PIN Number** (for example):

Followed by: "BEEP"

Note: If the Passive OWK doesn't learn the network code, it will give an error tone and return to Active mode. At any time to exit Passive Mode and return a OWK to Active mode, enter the Master PIN number, followed by "57".

7.2 MULTI-OWK DEFAULT GCU SETTING

A Passive OWK defaults to activating GCU #2 (See **Basic Gate Control Unit Installation**) when it is activated by a PIN code entered on that keypad.

To have the Passive OWK activate GCU #3, on the Passive unit:

Enter the **Master PIN Number** (for example):

Followed by:

To have the Passive OWK activate GCU #4, on the Passive unit:

Enter the **Master PIN Number** (for example):

Followed by:

7.3 PARTY MODE

To keep your gate open during a party or other activity, so the gate won't have to open with the arrival of each guest, you can set the Wireless Keypad Unit to keep the gate open, until it is cycled closed. To use this setting, the Gate Control Unit MUST be connected to an external +12 Volt power supply.

To enter Party Mode, on the Active OWK:

Enter the **Master PIN Number** (for example):

Followed by:

To close the gate and exit Party Mode, cycle the gate by entering a PIN number or by pressing the button on a Remote or Intercom.

7.4 VACATION MODE

If you are going to be gone for an extended length of time, the unit can be put into a Deep Sleep mode to conserve power and will only respond to the Master PIN number being entered on the Wireless Keypad Unit.

To enter Vacation Mode:

Enter the **Master PIN Number** (for example):

Followed by:

To exit Vacation Mode:

Enter the **Master PIN Number** (for example):

Followed by:

