

- NOTES:
- SEE CAD MODEL 093C0592 FOR FEATURE DIMENSIONS NOT CONTROLLED ON THIS DRAWING. TOLERANCES OF GEOMETRY ARE PER SPI "STANDARDS AND PRACTICES OF PLASTIC MOLDERS" ENGINEERING AND TECHNICAL STANDARDS FOR SPECIFIED MATERIAL. TOLERANCES DISPLAYED ON THIS DRAWING SUPERCEDE THOSE OF SPI. TOLERANCES UNDER .005 INCH ONLY APPLICABLE WHERE SPECIFIED ON THIS DRAWING.
  - MATERIAL: ABS, HIVAL HG6.
  - COLOR: STANDARD KHAKI.
  - SEE CHAMBERLAIN STANDARD PRODUCT SPEC. 190A0280 FOR GENERAL TOOLING AND PROCESSING. SECTIONS 1.2 AND 1.3 DO NOT APPLY, REFER TO DATABASE.
  - GATE VESTIGE TO BE +.005 INCHES MAXIMUM OR BELOW SURFACE.
  - PART NUMBER, ISSUE LETTER & CAVITY NUMBER (IN MULTI-CAVITY TOOL) TO BE MOLDED IN THE AREA INDICATED IN 1/32 AND 1/8 INCH HIGH CHARACTERS RAISED TO .010 INCH ABOVE THE SURFACE.
  - EXTERIOR SURFACE TEXTURE: CLASS-A MOLDTECH MT-11020 EXCEPT WHERE NOTED
  - SURFACES WITH NO SPECIFIED FINISH TO BE IN THE RANGE OF SPI BI-C3 (TYPICAL UNLESS DIAMOND POLISH IS NEEDED).
  - DIMENSIONS MARKED WITH "\*" ARE PROCESS CRITICAL AND NEED TO BE CONTROLLED AND MONITORED IN THE MANUFACTURING PROCESS. THESE DIMENSIONS ARE TO BE SELECTIVELY AUDITED AT CGI.
  - PARTS MUST COMPLY WITH HAZARDOUS MATERIALS REGULATIONS, AND COMPLIANCE MUST BE INDICATED ON EACH SHIPMENT PER 190A0790.
  - NOMINAL WALL THICKNESS: 0.100

PART NUMBER: 093C0592		SHT 1 OF 1	A
ECN/DATE	BY	REVISIONS	REV
09-0187 29MAY09	MK	INITIAL RELEASE	A

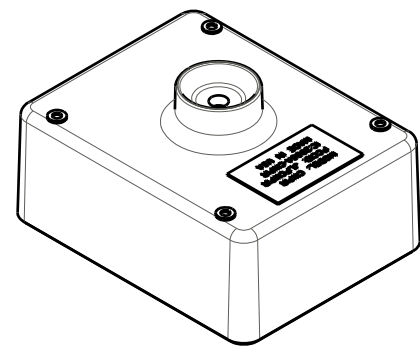

SCALE 0.500

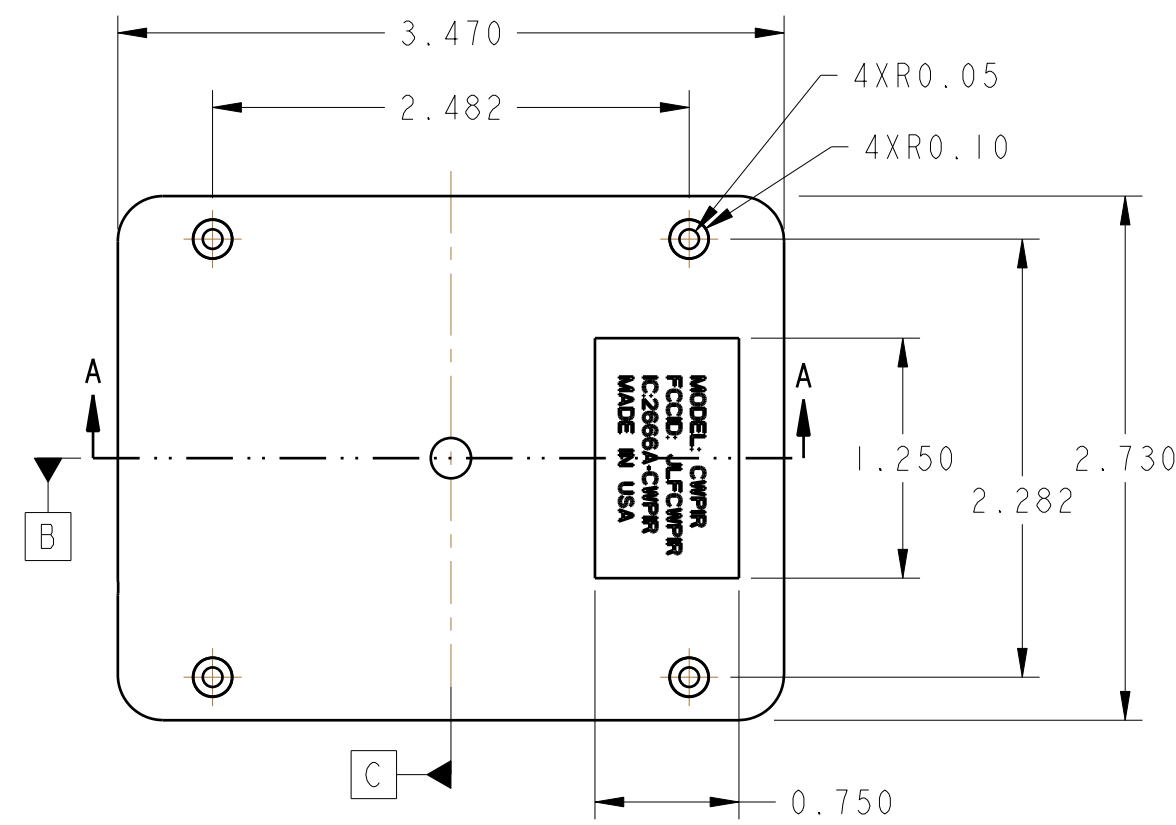
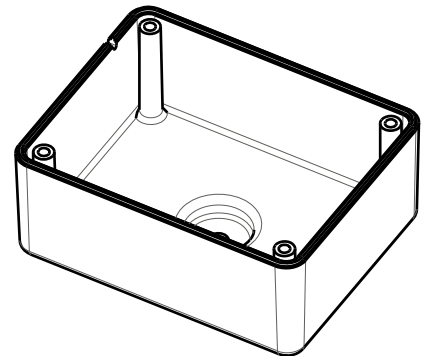

SCALE 0.500

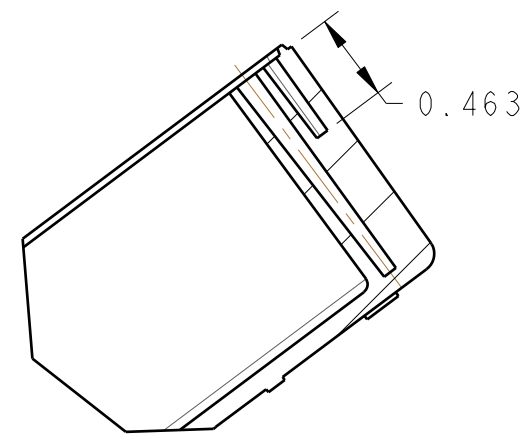

SECTION C-C  
4 PLACES

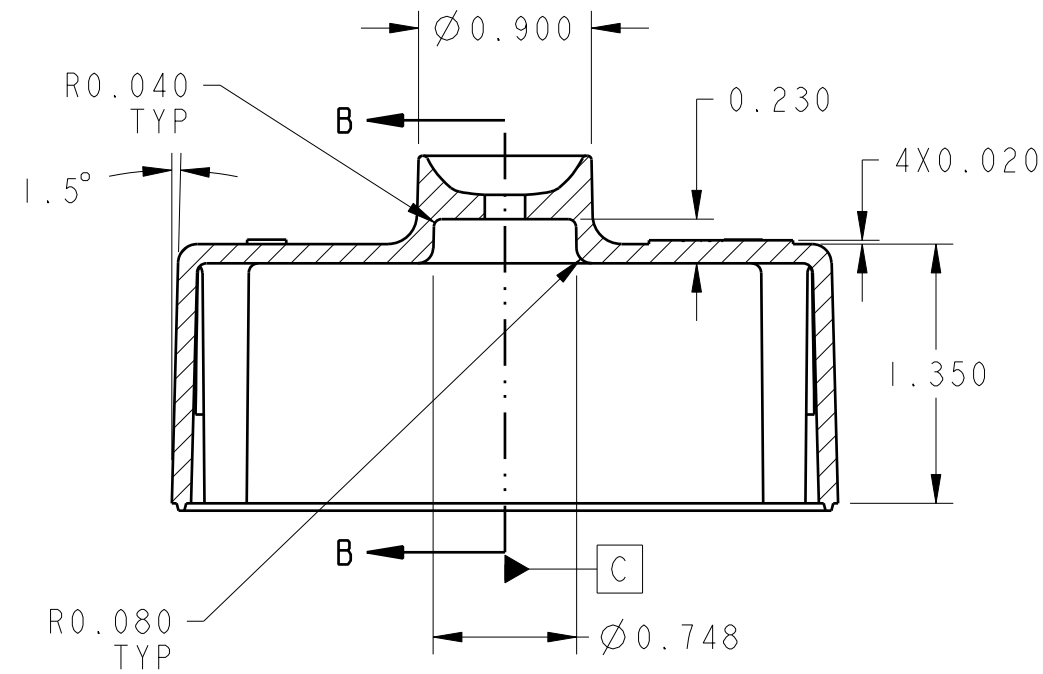

SECTION A-A

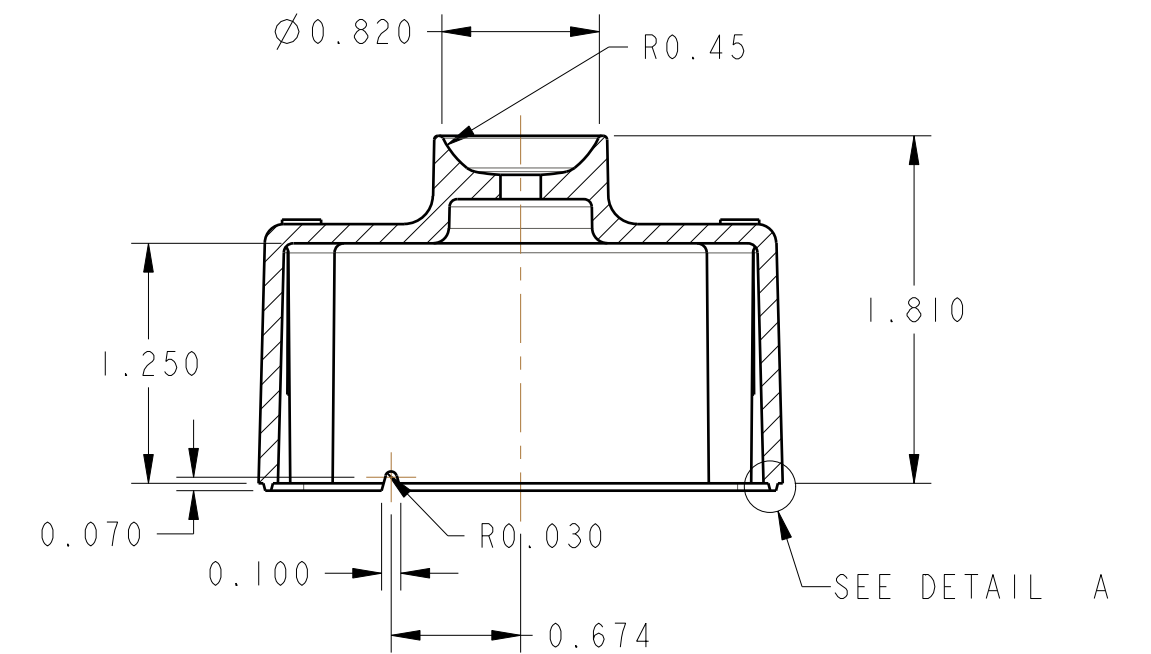

SECTION B-B

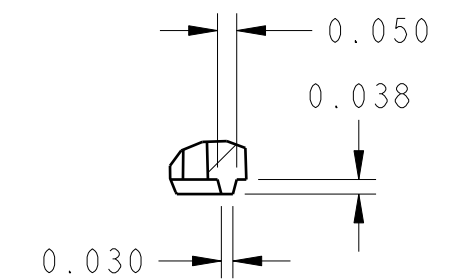
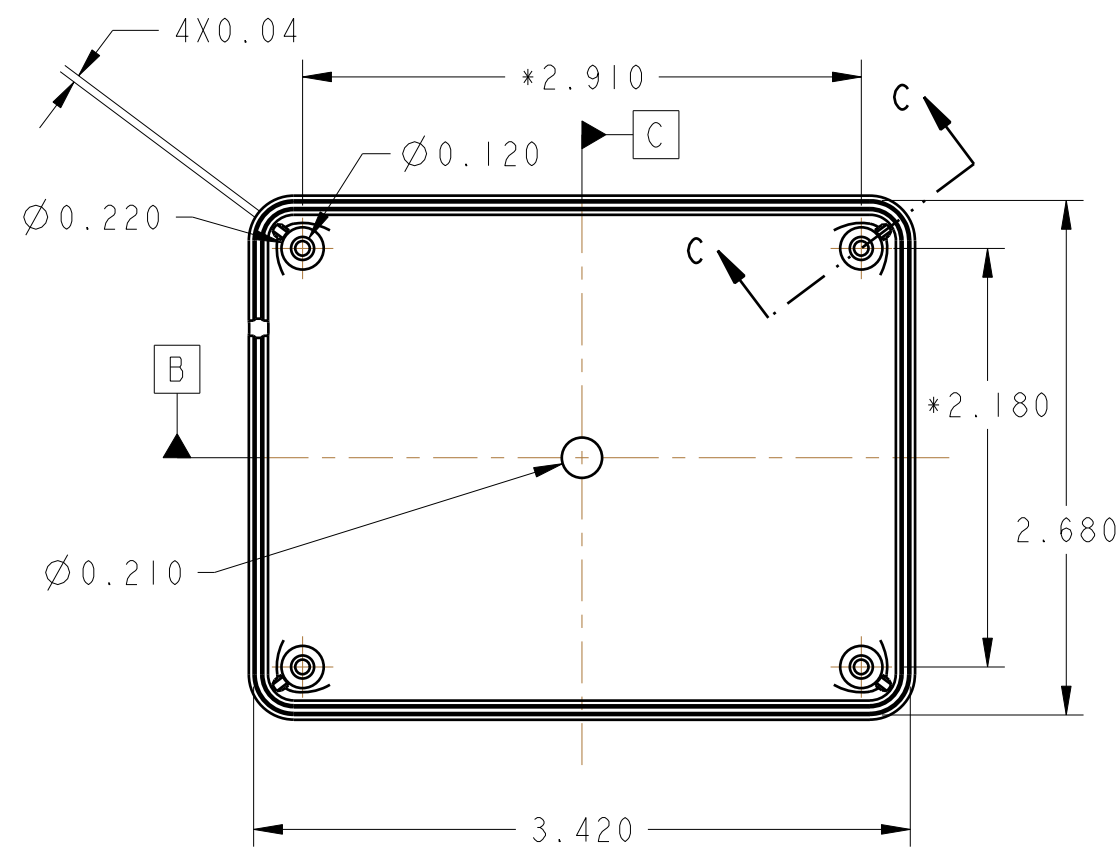

DETAIL A  
SCALE 2.000

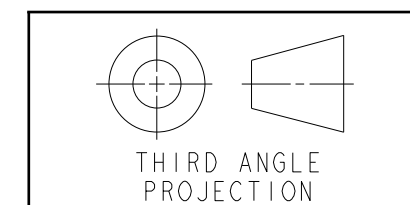

THIRD ANGLE  
PROJECTION

**CHAMBERLAIN**

NAME  
HOUSING, PCB, PIR

CONFIDENTIAL  
THIS DRAWING, ANY INFORMATION CONTAINED HEREIN, AND ANY ASSOCIATED DATA AND MATERIALS (COLLECTIVELY "INFORMATION") IS THE SOLE AND EXCLUSIVE PROPERTY OF, AND IS PROPRIETARY TO, THE CHAMBERLAIN GROUP, INC. THIS INFORMATION MAY NOT BE REPRODUCED, COPIED, MODIFIED, DISCLOSED, TRANSFERRED OR MADE AVAILABLE TO OTHERS, IN WHOLE OR IN PART, WITHOUT THE PRIOR EXPRESS WRITTEN CONSENT OF CHAMBERLAIN.

TOLERANCES EXCEPT AS NOTED:  
(IN)  
±0.01 .00 DECIMAL  
±0.005 .000 DECIMAL  
±1.0° ON ANGLES  
±0.003 ON HOLES

DO NOT SCALE DRAWING

FINISH  
SEE NOTES

MATERIAL  
SEE NOTES

THIS IS A COMPUTER GENERATED DRAWING  
DO NOT CHANGE THIS DOCUMENT WITHOUT  
UPDATING THE COMPUTER DATABASE

THIS  
COPY  
ISSUED:

DRAWN	BY	DATE	SCALE	PART NUMBER	SHEET	REV
PRA		21APR09	1.00	093C0592	1 of 1	A