

TOSHIBA

TOSHIBA HOKUTO ELECTRONICS CORPORATION
MAGNETRON ENGINEERING DEPARTMENT
1975, 23-CHOME, MINAMI 5-JODORI, ASAHIKAWA, HOKKAIDO 078, JAPAN
PHONE: (0166) 31-4728 FACSIMILE: (0166) 35-5671

Mr. R. Kanemitsu
Manager
Overseas Department
Nissin Industry Co., Ltd.
3-2-11, Shibukawa-cho,
Higashi Osaka City
Japan

January 14, 1998
(Ref. No. : 98-005)

RE : Electromagnetic radiation from Nisshin microwave oven
with Toshiba magnetron 2M240H(IF),5

Dear Mr. Kanemitsu

We are enclosing herewith the above mentioned test results based on FCC measuring method in our measuring facility of FCC file number 430A.

We confirmed test results are satisfied with FCC limit.

Please feel free to contact us, if you have any question or request.

Sincerely yours,



Toshiki Azuma
Deputy Senior Manager
Magnetron Application Engineering
Magnetron Engineering Department

AZ/SJ/sg

cc : Mr. Nakazawa TOSHIBA HOKUTO OSAKA
Mr. Ikegami TOSHIBA HOKUTO TOKYO

47HU105Z
EXHIBIT "B" 1 OF 2
NISSHIN IND. CO., LTD. (USA)
645 Dauphine Ct., Suite D
Elk Grove, IL 60007

ELECTROMAGNETIC RADIATION TEST OF MICROWAVE OVEN

The following measurements were conducted in Toshiba Hokuto Electronics Corporation measurement facility of FCC file number 430A.

Date : 1998-1-12
Oven : MO-105
Tube : 2M240H(IF),5
Line : 120V/60Hz

1. Output power (Load : 1000ml water (center))

Input power : 1580W
Output power : 970W
* Permissible FIS = $34.8 \mu\text{V/m}$ at 300m
(FIS : Field Intensity Strength)

2. Power Leak (Load : 275ml water (center))

Po leak : 0.15 mW/cm^2

3. FIS measurements

Measurement equipment (Refer Page-4)

Interference analyzer : EMC-60 MK-IV (Bandwidth : 5MHz)
Antenna : CA-S, CA-M and CA-X

3-1 Side band radiation (Load : 700ml water (center))

Frequency (MHz)	FIS ($\mu\text{V/m}$) at 300m
2,358	3.3
2,531	5.6

3-2 Harmonics radiation

Harmonics	Load	FIS($\mu\text{V/m}$) at 300m	Frequency (MHz)
2nd	300ml side	22.9	4,887
3rd	700ml side	30.1	7,333
4th	700ml center	32.7	9,796

Note : 2nd and 3rd Harmonics : The maximum value with the load condition such as 300ml or 700ml water in the center or side position

4. Frequency measurements

Measurement equipment (Refer Page-4)

Interference analyzer : EMC-60 MK-IV (Bandwidth : 5MHz)

Antenna : CA-S, CA-M and CA-X

4-1 The variation of frequency for load variation (Load : 1000ml water center)

Volume of water (ml)	Frequency (MHz)
1000	2,448
800	2,450
600	2,452
400	2,453
200	2,451

4-2 The variation of frequency for line voltage variation (Load : 1000ml water center)

Line voltage (V)	Frequency (MHz)
96	2,449
108	2,450
120	2,448
132	2,448
150	2,448

5. Frequency sweeping

Measurement equipment (Refer Page-4)

Spectrum analyzer : HP8562A

Antenna : CA-S, CA-M and CA-X

None of higher FIS value than those shown in the above table existed in the following frequency band.

Frequency (MHz)	Load condition
2000 - 2400	700ml center
2500 - 4000	
4000 - 8000	300ml or 700ml water in the center or side position
8000 - 10000	700ml center

No.	Equipment Name	Model Name & Manufacturer	Specification	Last Calibration Date	Calibration Frequency
1	Interference Analyzer	EMC-60 MK-IV SER. : 44116 ELECTRO-METRICS	0.5 to 18 GHz	April 1997	
2	Antenna	(1) CA-S SER : 22-1 POLARAD	2.1 to 4.34 GHz		
		(2) CA-M SER : 20-15 POLARAD	4.19 to 7.74 GHz		
		(3) CA-X SER : 20-10 POLARAD	7.36 to 10 GHz		
3	Signal Generator	8671B SER : 2545A00106 HEWLETT PACKARD	2.0 to 18 GHz	March 1997	
4	Frequency Counter	85340A SER : 134A01280 HEWLETT PACKARD		March 1997	Annually
5	Power Meter	435A SER : 1312J00144 HEWLETT PACKARD	0 to 1 mW	March 1997	Annually
6	Power Sensor	8481A SER : 1234A871 HEWLETT PACKARD		March 1997	
7	Spectrum Analyzer	8562A SER : 2923A03932 HEWLETT PACKARD	1 kHz to 22 GHz	March 1997	

ENGINEERING TEST REPORT

Page . 1

DEC 23, 1997

Report No . CALR-FCC-086

This is to certify that the MICROWAVE OVEN from which the following data has been derived properly complies with the requirements of " FCC Rules and Regulations Part 18 Subpart C " as of the date the measurements were made.

1. Manufacturer of Device : NISSHIN INDUSTRY CO., LTD.
3-2-11 SHIBUKAWA-CHO
HIGASHI OSAKA CITY JAPAN

2. Description of Device

a. FCC ID. : JHU105Z
b. Model No. : MW8106W
c. Serial No. : 3900000001
d. Operating Frequency : 2450 MHz
e. Output RF Power : 1000 W (BY IEC 705)
f. Power Consumption : 120 V. 60 Hz
g. Magnetron Type : Matsushita 2M167
h. Employed Mode : Turn Table
i. Door Seal Type : Choke

3. Measurement Procedure Used : FCC/OST MP-5

4. Measurement Site

Name : Panasonic Magnetron Lab.
Panasonic Industrial Company

Address : 1707 N. Randall Road
Elgin, Illinois 60123-7847

Description of this test facility has been filed with the FCC. (Feb. 26, 1987,
File # 31010/EQU 4-3-0A)

JHU105Z
EXHIBIT "B" 2 OF 2
NISSHIN IND. CO., LTD. (USA)
645 Dauphine Ct., Suite D
Elk Grove, IL 60007

5. Date of Measurement : DEC 23, 1997

6. Measurement Data : See Attached " Data Summary "

7. Test Equipment Used : See Exhibit 1

Tested By

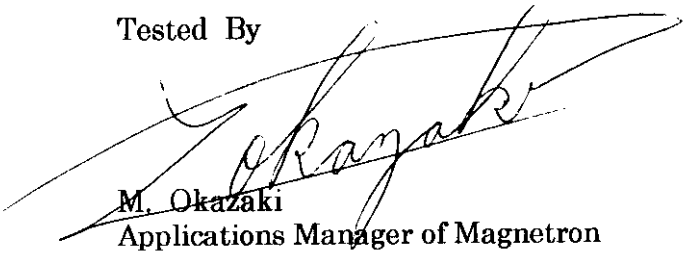
A large, stylized handwritten signature in black ink, appearing to read 'M. Okazaki', is written over the printed name and title.

M. Okazaki
Applications Manager of Magnetron
Panasonic Industrial Company

DATA SUMMARY

1. Safety Check : < 0.5 mW/cm² @ 5cm

2. Radiated Field Strength uV/m @ 300m

	Frequency (MHz)	Field Strength (uV/m)	Permissible (uV/m)
Fundamental	2451	1961	-----
2nd Harmonic	4903	7.33	31.9
3rd Harmonic	7353	3.87	31.9
4th Harmonic	9805	2.14	31.9
Spurious	2530	0.43	31.9
Emission Side Band	2400	0.26	31.9
Emission Side Band	2500	0.26	31.9

3. Maximum frequency variation : 2448 MHz - 2451 MHz
(96V ~ 150V / 1000cc Load)

2451 MHz - 2461 MHz
(1000cc ~ 200cc / Load)

4. Total power input to oven : 1560 W

5. Power developed in dummy load : 813 W

6. Supply voltage : 120V , 14.5 A

Description of Instrumentation and calculation

(1) Measurement equipment

a. Field Strength Meter : Electro-Metrics Model EMC-50

Bandwidth Setting : 1 MHz

Detector Function : Linear Average Detection

b. Receiving Antenna : Electro-Metrics Model RGA-180

Frequency Range : 1 - 18 GHz

c. Microwave Survey Meter : Narda Model 8110B

(2) Test Condition

a. Antenna Height Variation : 1.0 - 1.5 m

b. Distance of Antenna to Test unit : 3.0 m

c. Test Unit Height : 1.0 m

(3) Calculation Formula

Field Strength at 3 m (dBuV/m)

$$= \text{Receiver Reading (dBuV)} + \text{Antenna Factor (dB/m)} + \text{Cable Loss (dB)}$$

Field Strength at 300m (uV/m)

$$= K * 10^{\frac{\text{Field Strength at 3 m (dBuV/m)}}{20}}$$

K : Conversion Factor for 3 m to 300 m

Frequency (MHz)	Antenna Factor (dB/m)	Cable Loss (dB)	Conv. Factor K
2400	29	0.7	0.0061
Fundamental	29.3	0.7	0.0062
2500	29.5	0.7	0.0063
4900	33.4	0.9	0.01
7350	36.5	1.2	0.01
9800	38.2	1.4	0.01

Example : 2nd Harmonics

Receiver Reading = 20 dB @ 3 m

$$\text{FIS @300 m} = 0.01 * 10^{\frac{20 + 33.4 + 0.9}{20}} = 5.19 \text{ (uV/m)}$$

Exhibit 1 Test Equipment List

Name / Model No.	S / No.	Manufacturer	Last Calibrated
Field Strength Meter Model EMC - 50	175	Electro Metrics	11 / 14 / 97
Microwave Survey Meter 8110B	20915	Narda	06 / 13 / 97
Ridged Guide Antenna RGA - 180	2455	Electro Metrics	08 / 20 / 88
Network Analyzer 8410B	1647A00704	Hewlett Packard	06 / 17 / 88
Reflection Unit 8743A	1330A01358	Hewlett Packard	06 / 17 / 88
Sweep Oscillator 8620C	1645A00827	Hewlett Packard	06 / 17 / 88
Frequency Meter 536A	1441A00695	Hewlett Packard	09 / 17 / 88
Power Meter 436A	1629A1172	Hewlett Packard	08 / 05 / 89
Spectrum Analyzer 8555A	1642A06830	Hewlett Packard	08 / 21 / 88

Fig. 1 Physical Description of Test Site

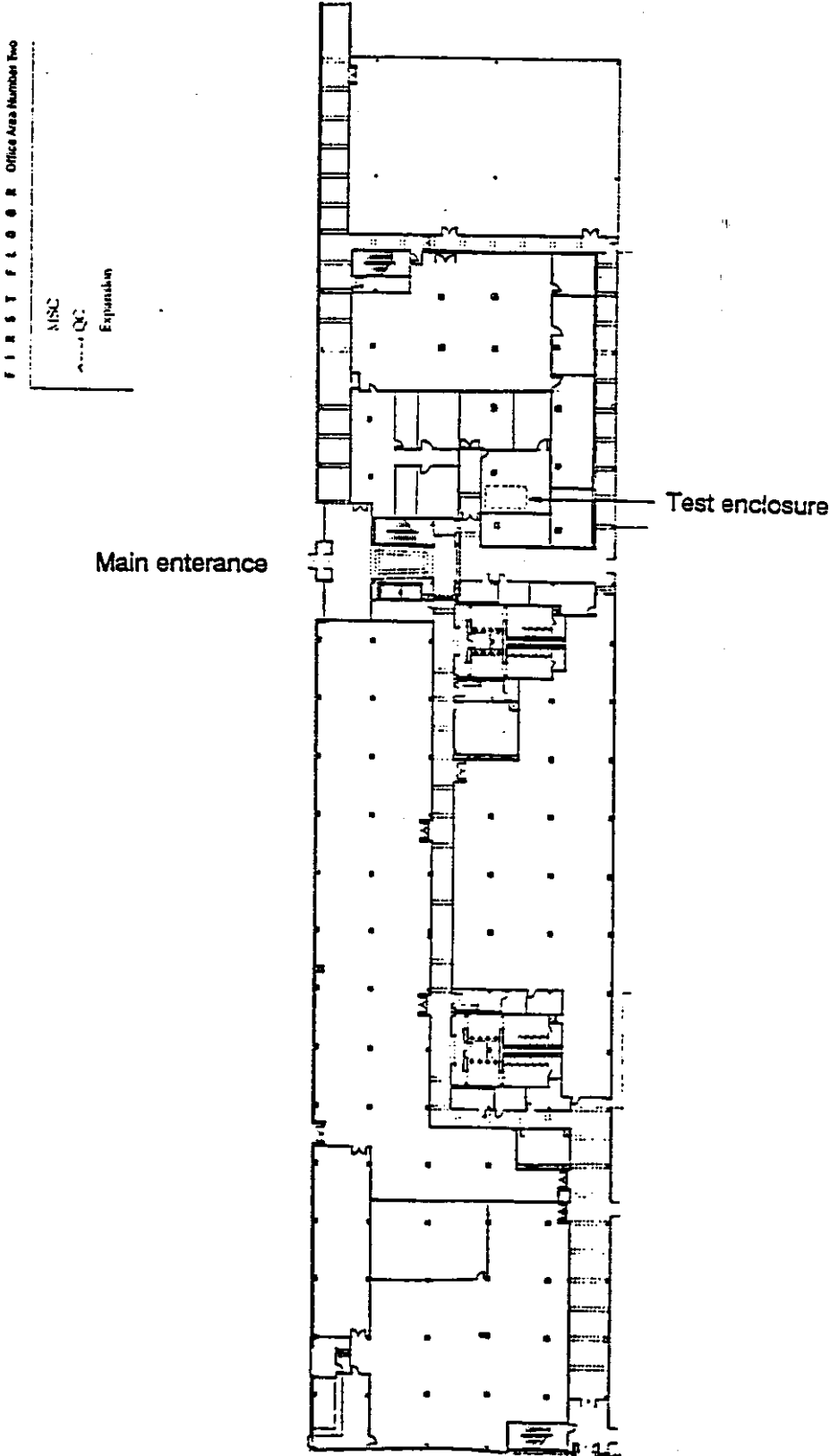
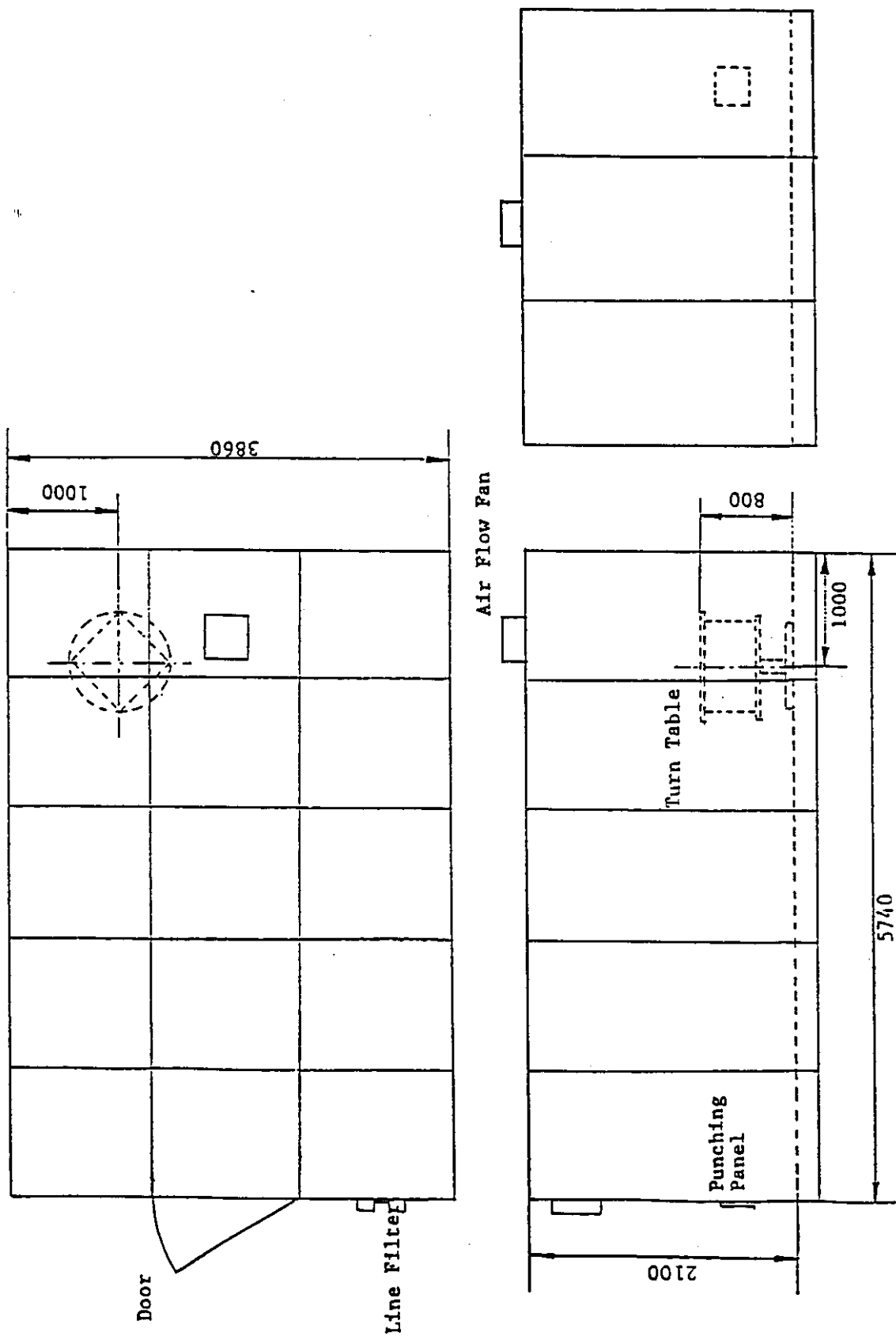

Fig. 2 Physical Dimensions of Test Site (Unit mm)





NISSHIN INDUSTRY CO., LTD.

HEAD OFFICE : 3-2-11 SHIBUKAWA CHO HIGASHI OSAKA CITY JAPAN

TEL : (06) 7 2 0 - 1 7 8 1 FAX : (06) 7 2 1 - 5 9 8 5

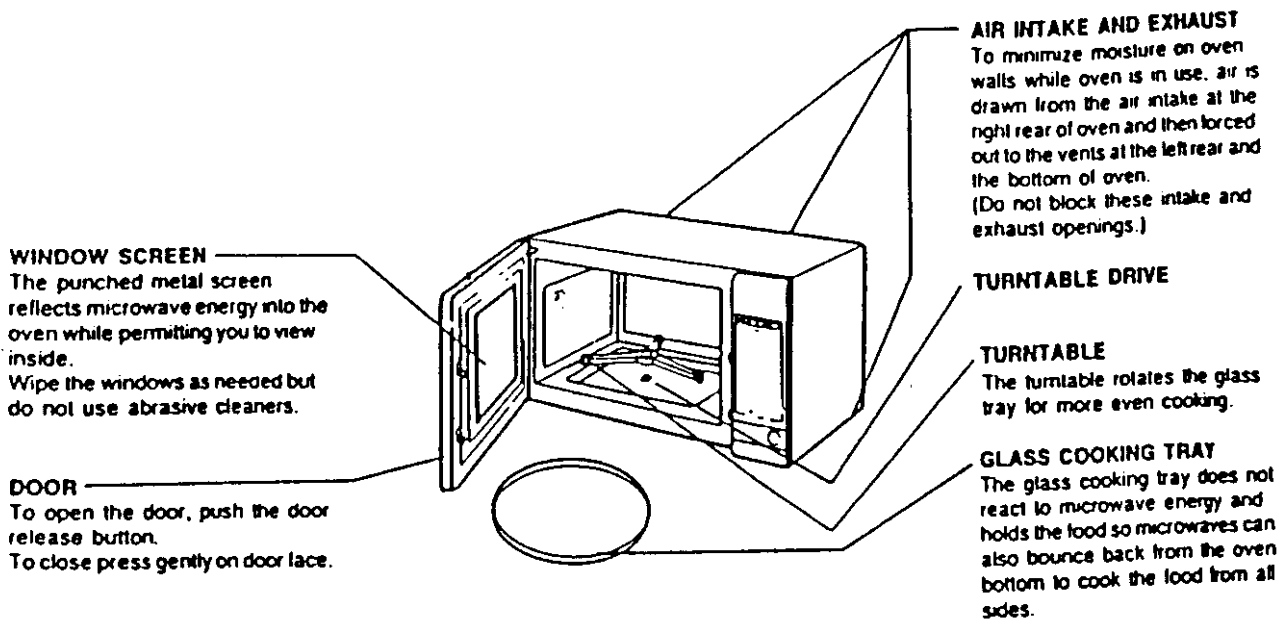

If this oven is dropped or damaged, do not use it until it is thoroughly checked by a trained service technician. This oven has a short power supply cord. Extension cords may be used if you are careful in their use. If an extension cord is used, it must be a type S, with 3 number 16 wires and have a 3-prong grounded plug. The extension cord should not drape over a countertop where it can be pulled on or tripped over accidentally. The electrical power cord must be kept dry and must not be pinched or crushed in any way. Do not store burnable material, such as food, in a microwave oven.

THIS MICROWAVE OVEN IS DESIGNED FOR HOUSEHOLD USE ONLY AND MUST NOT BE USED FOR COMMERCIAL PURPOSES.

- This oven may possibly cause reception interference on radio and/or televisions.
- In order to eliminate or minimize interference to radios and televisions from this microwave oven, the oven should be on a separate electrical circuit within the building. In addition, the oven should be physically as far away from the radio or television as possible.
- There are no user maintenance requirements for this appliance, except for normal cleaning as outlined in this owner's manual.

TEXT IN OWNERS' MANUAL, PAGE 9

FCC ID: JHU105Z

EXHIBIT "D"

1 OF 1