

---

## System 10 Stompbox

Digital Wireless System  
*Installation and Operation*

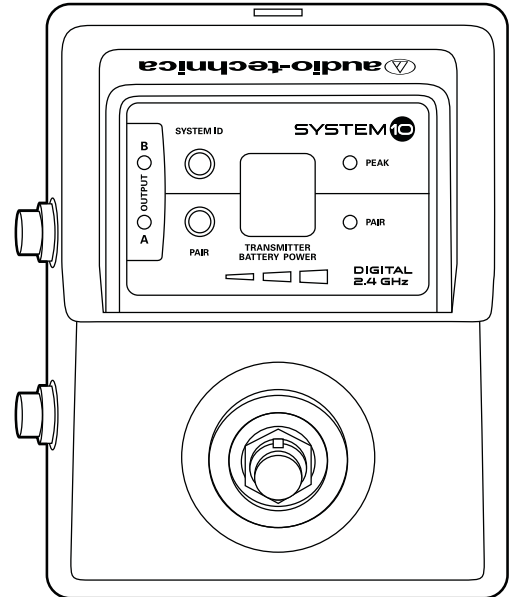

**ATW-1501**  
*Stompbox Wireless System*

## System 10 Stompbox Installation and Operation



**CAUTION**  
**RISK OF ELECTRIC SHOCK**  
**DO NOT OPEN**



**WARNING:** TO REDUCE THE RISK OF FIRE OR ELECTRIC SHOCK, DO NOT REMOVE SCREWS. NO USER-SERVICEABLE PARTS INSIDE. REFER SERVICING TO QUALIFIED SERVICE PERSONNEL.

**WARNING:** TO REDUCE THE RISK OF FIRE OR ELECTRIC SHOCK, DO NOT EXPOSE THE APPLIANCE TO RAIN OR MOISTURE.

**CERTIFICATION:** THIS DEVICE COMPLIES WITH PART 15 OF THE FCC RULES. THIS DEVICE COMPLIES WITH INDUSTRY CANADA LICENSE-EXEMPT RSS STANDARD(S). OPERATION IS SUBJECT TO THE FOLLOWING TWO CONDITIONS: (1) THIS DEVICE MAY NOT CAUSE HARMFUL INTERFERENCE, AND (2) THIS DEVICE MUST ACCEPT ANY INTERFERENCE RECEIVED, INCLUDING INTERFERENCE THAT MAY CAUSE UNDESIRE OPERATION.

Cet appareil est conforme à la/aux norme(s) RSS exempte(s) de licence d'Industrie Canada. Son fonctionnement est soumis aux deux conditions suivantes : (1) cet appareil ne doit pas causer d'interférence et (2) cet appareil doit accepter toutes les interférences, y compris celles susceptibles de provoquer un fonctionnement non souhaité.

**WARNING:** Changes or modifications not expressly approved in writing by Audio-Technica may void the user's authority to operate this equipment.

**RF Exposure Statement:** This transmitter must not be co-located or operated in conjunction with any other antenna or transmitter.

This equipment complies with FCC/IC radiation exposure limits set forth for an uncontrolled environment and meets the FCC radio frequency (RF) Exposure Guidelines and RSS-102 of the IC radio frequency (RF) Exposure rules. This equipment has very low levels of RF energy that it deemed to comply without maximum permissive exposure evaluation (MPE). But it is desirable that it should be installed and operated keeping the radiator at least 20cm or more away from person's body.

Cet équipement est conforme aux limites d'exposition aux rayonnements énoncées pour un environnement non contrôlé et respecte les règles d'exposition aux fréquences radioélectriques (RF) CNR-102 de l'IC. Cet équipement émet une énergie RF très faible qui est considérée conforme sans évaluation de l'exposition maximale autorisée. Cependant, il est souhaitable qu'il devrait être installé et utilisé en gardant une distance de 20 cm ou plus entre le dispositif rayonnant et le corps.

**Note:** This equipment has been tested and found to comply with the limits for a Class B digital device, pursuant to part 15 of the FCC Rules. These limits are designed to provide reasonable protection against harmful interference in a residential installation. This equipment generates, uses and can radiate radio frequency energy and, if not installed and used in accordance with the instructions, may cause harmful interference to radio communications. However, there is no guarantee that interference will not occur in a particular installation. If this equipment does cause harmful interference to radio or television reception, which can be determined by turning the equipment off and on, the user is encouraged to try to correct the interference by one or more of the following measures:

- Reorient or relocate the receiving antenna.
- Increase the separation between the equipment and receiver.
- Connect the equipment into an outlet on a circuit different from that to which the receiver is connected.
- Consult the dealer or an experienced radio/TV technician for help.

This Class B digital apparatus complies with Canadian ICES-003.

Cet appareil numérique de la classe B est conforme à la norme NMB-003 du Canada.

**CAUTION!** Electrical shock can result from removal of the receiver cover. Refer servicing to qualified service personnel. No userserviceable parts inside. Do not expose to rain or moisture. The

circuits inside the receiver and transmitter have been precisely adjusted for optimum performance and compliance with federal regulations. Do not attempt to open the receiver or transmitter. To do so will void the warranty, and may cause improper operation.

**Notice to individuals with implanted cardiac pacemakers or AICD**

**devices:** Any source of RF (radio frequency) energy may interfere with normal functioning of the implanted device. All wireless microphones have low-power transmitters (less than 0.05 watts output) which are unlikely to cause difficulty, especially if they are at least a few inches away. However, since a "body-pack" mic transmitter typically is placed against the body, we suggest attaching it at the belt, rather than in a shirt pocket where it may be immediately adjacent to the medical device. Note also that any medical-device disruption will cease when the RF transmitting source is turned off. Please contact your physician or medical-device provider if you have any questions, or experience any problems with the use of this or any other RF equipment.

**Important Safety Instructions**

1. Read these instructions.
2. Keep these instructions.
3. Heed all warnings.
4. Follow all instructions.
5. Do not use this apparatus near water.
6. Clean only with a dry cloth.
7. Install in accordance with the manufacturer's instructions.
8. Do not install near any heat sources such as radiators, heat registers, stoves, or other apparatus (including amplifiers) that produce heat.
9. Unplug this apparatus during lightning storms or when unused for long periods of time.
10. Refer all servicing to qualified service personnel. Servicing is required when the apparatus has been damaged in any way, such as power-supply cord or plug is damaged, liquid has been spilled or objects have fallen into the apparatus, the apparatus has been exposed to rain or moisture, does not operate normally, or has been dropped.

Thank you for choosing an Audio-Technica professional wireless system. You have joined thousands of other satisfied customers who have chosen our products because of their quality, performance and reliability. This wireless microphone system is the successful result of years of design and manufacturing experience.

Audio-Technica's System 10 Stompbox is a digital wireless system designed to provide rock-solid performance along with easy setup and clear, natural sound quality. Operating in the 2.4 GHz range, far from TV and DTV interference, System 10 Stompbox offers a small, portable receiver with foot switch, two switched TRS balanced ¼" outputs and an output mode selector. The receiver can be paired with up to eight UniPak® body-pack transmitters, allowing musicians to easily switch instruments.

System 10 wireless ensures clear communications by providing three levels of diversity assurance: frequency, time, and space. Frequency Diversity sends the signal on two dynamically allocated frequencies for interference-free communication. Time Diversity sends the signal in multiple time slots to maximize immunity to multipath interference. Finally, Space Diversity uses two antennas on each transmitter and receiver to maximize signal integrity.

Each System 10 Stompbox professional digital wireless system includes an ATW-R1500 Stompbox receiver, an ATW-T1001 UniPak body-pack transmitter with an AT-GcW guitar cable, and Velcro® strips for adding receiver to an effects pedal board. All A-T Wireless Essentials® microphones and cables, available separately, are pre-terminated for use with any ATW-T1001 transmitters.

## System 10 Stompbox Installation and Operation

**Note:** ATW-T1001 transmitters from earlier System 10 models may not be compatible with the multi-transmitter pairing and battery level indicator functions of the System 10 Stompbox receiver. However, these older transmitter models may be shipped to the Audio-Technica Service Department for firmware updates.

The ATW-R1500 receiver includes a switching power supply that automatically adapts to changes in mains voltage.

The versatile ATW-T1001 UniPak body-pack transmitter has both a high-impedance input for instruments, and a low-impedance input with bias connection for use with dynamic and electret condenser microphones.

The transmitter uses internal AA batteries and has a Power/Mute switch and input Trim (level) adjustment.

### Receiver Installation

#### Location

For best operation, the receiver should be at least 3' (1 m) away from a wall or metal surface to minimize reflections. Keep the receiver away from noise sources such as other digital equipment, microwave ovens,

as well as away from large metal objects. **Keep System 10 Stompbox receiver 30' (9 m) away from wireless access points.** Operating transmitters should be kept at least 3' (1 m) from receiver, but will continue to work up to 60' (18 m) from receiver line of sight.

#### Output Connection

There are two switched TRS balanced ¼" output jacks on the side panel. Either output can be connected to a guitar amp, a tuner or an effects pedal.

#### Power Connection

Connect the DC plug on the included AC power adapter to the DC power input on the back of the receiver. Then plug the adapter into a standard 120 Volt 60 Hz AC power outlet. The receiver may also be used in conjunction with an effects pedal board with a common power supply, but each output must be "isolated" in order to prevent noise interference.

(Note that the receiver has no power Off/On switch. The receiver will be energized whenever the power adapter is connected and plugged into the AC outlet. Unplug the power supply from the AC outlet when the system is not in use — both for safety, and to conserve energy.

### ATW-R1500 Receiver Controls and Functions

#### Figure A — Top Panel Controls and Functions

1. Audio Output B: Switched TRS balanced ¼" phone jack. Can be connected to guitar amp, tuner or effects pedal input.
2. Audio Output A: Switched TRS balanced ¼" phone jack. Can be connected to guitar amp, tuner or effects pedal input.
3. A/B Output Indicators: Glows green if output is on, glows red if output is off or muted.
4. System ID Select Switch: Press to cycle through System ID numbers or to clear pairing. (System ID is an identical number assigned to a paired receiver and transmitter for identification purposes.)
5. Pairing Switch: Press and hold to initiate or clear pairing.
6. System ID Display: Shows System ID number.
7. Foot Switch: Press to toggle between outputs.
8. AF Peak Indicator: Only lights when audio distortion is present at maximum input.
9. Pair Indicator: Glows green to indicate presence of paired transmitter. Also blinks green to indicate pairing mode activated.
10. Transmitter Battery Power Indicator

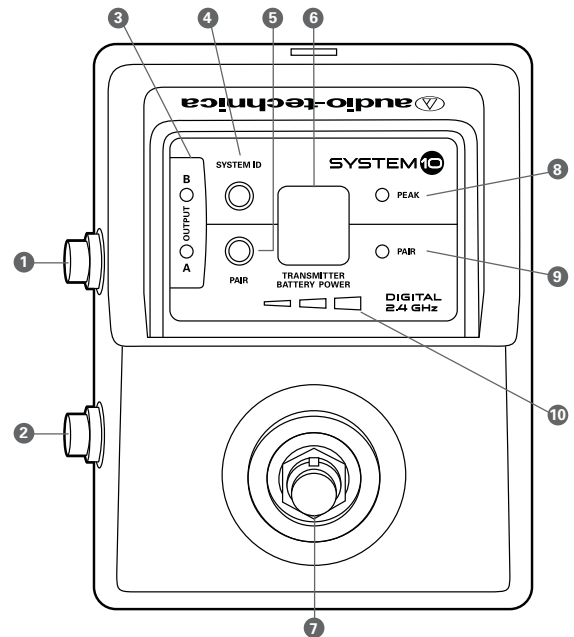

#### Figure B — Rear Panel Controls and Functions

1. Output Mode Selector: Use to switch between A or B Mode and A Mute Mode.
2. Power Input Jack: Universal (center + or -) 9V-12V DC input. Connect the DC plug from the included AC adapter.

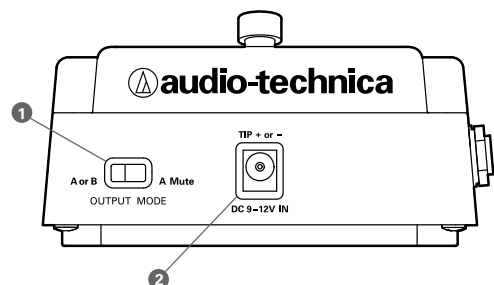

## System 10 Stompbox Installation and Operation

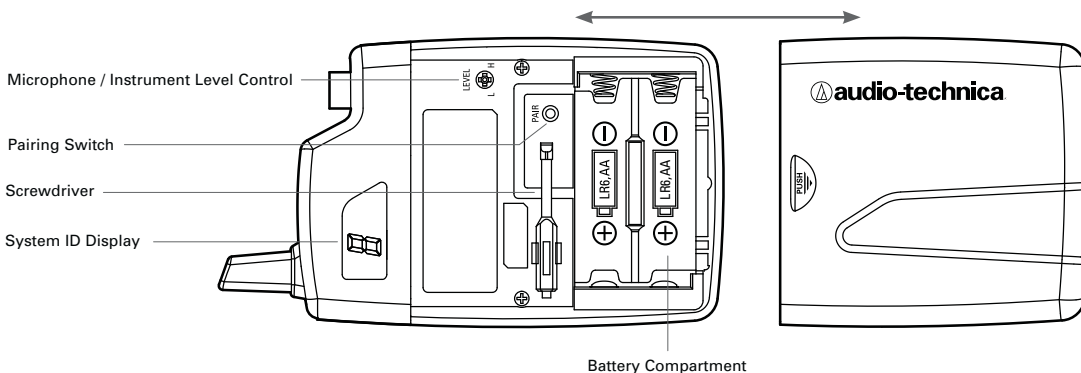

**Figure C — ATW-T1001 UniPak® Transmitter**

### UniPak® Transmitter Battery Installation

1. Slide off the battery cover.
2. Carefully insert two fresh AA alkaline batteries, observing polarity markings.
3. Replace the battery cover (Fig. C).

### UniPak® Transmitter Power/Mute/Battery Indicator

After the battery is installed, press and hold the Power/Mute button until the indicator LED turns green (Fig. D). If the indicator LED does not light up when the power button is pressed, the batteries are installed incorrectly or they are dead. The indicator LED will flash to show low-battery condition. Press and hold the Power/Mute button again to turn the transmitter off.

### UniPak® Transmitter Mute Function

With the transmitter on, a slight touch of the Power/Mute button will toggle between muted and unmuted operation. Red indicator LED shows muted operation. Green indicator LED shows unmuted operation.

### UniPak® Transmitter Mute Lock Function

Transmitter must be off to activate mute lock. Press and hold the Pairing Switch and then press and hold the Power/Mute button until transmitter powers on. **Note:** There is no dot next to the System ID when mute lock is activated.

Transmitter must be off to deactivate mute lock. Press and hold the Pairing Switch and then press and hold the Power/Mute button until transmitter powers on. When deactivated, a dot will display next to the System ID.

### UniPak® Transmitter Input Connection

Connect an audio input device (microphone or guitar cable) to the audio input connector on the top of the transmitter. A number of Audio-Technica professional microphones and cables are available separately, pre-terminated with a UniPak® input connector (see [www.audio-technica.com](http://www.audio-technica.com)).

### UniPak® Transmitter Antenna

The UniPak® transmitter includes a permanently-attached antenna. If the received signal is marginal, experiment with different transmitter positions on your body or instrument; or try repositioning the receiver. Do not attempt to remove, replace or change the length of the transmitting antenna.

### UniPak® Transmitter Pairing Switch

Used to complete pairing sequence. See page 5.

**Figure D — UniPak® Transmitter**

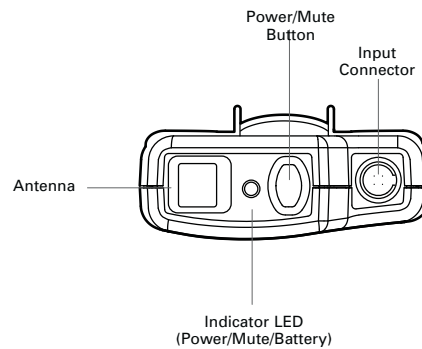

### UniPak® Transmitter Microphone/Instrument Level Control

Used to set microphone/instrument level. See page 5.

### UniPak® Transmitter Screwdriver

Used to adjust Level Control. See page 5.

### UniPak® Transmitter System ID Display

Shows System ID. See page 5. **Note:** System ID is an identical number assigned to a paired receiver and transmitter for identification purposes. When power is applied, the System ID Display on the transmitter glows bright and then turns off to conserve battery life. To turn the System ID Display back on, mute and unmute the transmitter.

## System Operation

Turn down the mixer/amplifier level before starting up the wireless system. Do not switch on the transmitter yet.

### Receiver on...

Plug the power supply into an AC power source. The blue System ID number on the front panel will illuminate.

### Transmitter on...

When the transmitter is switched on, the receiver's green pair indicator will light, and two indicators light on the transmitter: the transmitter Power / Battery / Mute status indicator will glow green; and the transmitter blue System ID display will illuminate. The blue System ID display on the transmitter turns off after 30 seconds to conserve battery power; the transmitter Power / Battery / Mute status indicator will remain illuminated, indicating transmitter status.

To re-illuminate System ID display, press the Power / Mute switch. **Note:** this will alter the transmitter mute status. A slight touch of the power switch toggles between muted and unmuted operation.

The transmitter's Power / Battery / Mute status indicator glows red when transmitter is muted, or green to indicated unmuted status. In a low-battery situation, the Power / Battery / Mute status indicator begins to blink.

The transmitters have a soft-touch power switch. When the switch is set to "Mute" (red indicator LED), the transmitter produces RF with no audio signal. When the switch is "On" (green indicator LED) the transmitter produces both RF and audio. Excessive audio input to the transmitter will cause the receiver's red AF Peak indicator to light.

### Input Level Adjustment

The transmitter's input trimmer control is factory-set for use with guitar. However, you can adjust the input level if need be. To do so, slide the battery cover off the transmitter and remove the screwdriver from its clip. Using the screwdriver, gently turn the "LEVEL" all the way up (clockwise, toward "H"). Check for excessive gain by playing instrument at typically loud levels while watching the receiver's Peak Indicator. If the Peak Indicator does light, turn the "LEVEL" control slightly counterclockwise until the Peak Indicator no longer lights with maximum audio input to the transmitter.

**CAUTION!** *The small trimmer control is delicate; use only the supplied screwdriver. Do not force the trimmer beyond its normal 190° range of rotation.*

*Return the screwdriver to its storage clip when not in use.*

### Setting System ID Number & Pairing your Transmitter and Receiver

Your system has been preconfigured at the factory to operate with no other pairing setup required; it will work out of the box. That is, your receiver and transmitter are already a digital pair, and they have been assigned the same System ID number.

The pairing instructions outlined below will help you change system ID numbers and pair additional transmitters to the receiver. Note: ATW-T1001 UniPak transmitters from earlier System 10 models may not be compatible with the multi-transmitter pairing and battery level indicator functions of the System 10 Stompbox receiver. However, these older transmitter models may be shipped to the Audio-Technica Service Department for firmware updates.

**Note: System ID is an identical number assigned to a paired receiver and transmitter for identification purposes.** The System ID number is not related to transmitting frequency. Due to the dynamic nature of System 10 automatic frequency selection, the actual transmitting frequencies may change during power-up or performance. These frequency changes are seamless and imperceptible to the ear.

### Pairing Receiver with Transmitters

**Note:** Up to eight transmitters may be paired with the receiver.

1. Turn the receiver and first transmitter on.
2. Press the System ID button on the receiver to choose an ID number from 1 to 8. The receiver's display will show your new ID and begin to blink.
3. Within 15 seconds, press and hold the Pair button on the receiver for about one second. The Pair light will begin to blink green. The receiver is now in Pair Mode.
 

**Note:** If the receiver Pair button is not pressed within 15 seconds, the system ID number will revert to its previous setting.
4. Open the transmitter and press and hold its Pair button within 30 seconds of entering Pair Mode. The transmitter display will now show the System ID number you have chosen on the receiver. The receiver's Pair light will glow steady, indicating you have successfully paired your system.
5. To pair an additional transmitter, you must switch off first transmitter by pressing and holding its Power/Mute button. Turn the second transmitter on and follow instructions 2-4 above, making sure to assign a different System ID number to the new transmitter.
6. Repeat for each additional transmitter. Remember to switch off all transmitters already paired before adding a new one and to use a unique ID number for each transmitter.

**Note:** With all transmitters turned off, the receiver's System ID Display will cycle through all currently paired ID numbers. Turn on a transmitter to activate its pairing with the receiver. The receiver recognizes only one transmitter at a time. That transmitter must be turned off before the receiver will recognize another paired transmitter. \*If that transmitter is turned off out of range, the receiver will not recognize another paired transmitter until the receiver is reset by disconnecting the power supply.

### Clearing Individual ID Pairings

1. Press the receiver's System ID button to select the ID number you wish to clear. The number will begin to blink.
2. Press and hold the Pair and then ID button for about three seconds, until the display shows a blinking "0." This indicates that your selected ID number has been cleared.
3. Release the Pair and ID buttons and, after a few seconds, the display will stop blinking and return to normal operation.
4. Repeat to clear additional ID pairings.

### Clearing All ID Pairings

1. Press and hold the receiver's Pair and then ID button for about three seconds, until the display shows a blinking "0."
2. Release the Pair and ID buttons. Then, within three seconds, press and hold the Pair and ID buttons again, until the display shows a blinking "A." This indicates that all your paired ID numbers have been cleared.
3. After blinking three times, the "A" will change to "\_" to indicate that there are no paired transmitters.

## System 10 Stompbox Installation and Operation

### Ten Tips to Obtain the Best Results

1. Use only fresh alkaline or fully charged rechargeable batteries.
2. Position the receiver so that it has the fewest possible obstructions between it and the normal location of the transmitter. Line-of-sight is best.
3. The transmitter and the receiver should be as close together as conveniently possible, but not less than 3' (1 m).
4. Please keep other wireless devices (including wireless systems and routers) away from System 10 receivers. For best performance, some routers and Wi-Fi-based wireless systems may need to be up to 30 feet away from System 10 receivers.
5. If the System 10 Stompbox receiver is used in conjunction with an effects pedal board with a common power supply, make sure each output is "isolated" in order to prevent noise interference.
6. As some guitar pickups may be overly sensitive to magnetic interference, please keep the System 10 UniPak® body-pack transmitter at least 1 foot away from guitar pickups.
7. Use the transmitter level control to optimize performance for your instrument, voice, or other sound source.
8. The A or B Output Mode is perfect for connecting to two different amps, allowing you, for example, to easily switch between amps when playing rhythm or lead guitar. The A Mute Output Mode is excellent for tuning on the fly: with Output B connected to a tuner, you can mute Output A, tune your guitar, then unmute Output A and continue playing.
9. Turn the transmitter off when not in use. Remove the battery if the transmitter is not to be used for a period of time.
10. Unplug the receiver from the AC outlet when the system is not in use.

### System Operating Frequencies

#### Automatic Frequency Selection

System 10 Stompbox wireless systems operate in automatically selected frequencies in the 2.4 GHz range, far from TV and DTV interference. Up to eight channels may be used together without any frequency coordination problems or group selection issues. Every time a receiver/transmitter pair is powered on, it automatically selects clear frequencies. Due to the dynamic nature of System 10 automatic frequency selection, these transmitting frequencies may change during power-up or performance if interference is encountered. These frequency changes occur at both the receiver and transmitter; they are seamless and imperceptible to the ear.

### System Frequencies

For future reference, please record your system information here (the serial number appear on each transmitter, and on the bottom of each receiver):

<b>Receiver</b>	
Model ATW-R1500	Serial Number _____
<b>Transmitter</b>	
Model ATW-T1001	Serial Number _____



## System 10 Stompbox Installation and Operation

### Specifications

#### OVERALL SYSTEM

Operating Frequencies	2.4 GHz ISM band
Dynamic Range	>109 dB (A-weighted), typical
Total Harmonic Distortion	<0.05% typical
Operating Range	18.3 m (60') radius, 36.6 m (120') diameter typical <i>Open range environment with no interfering signals</i>
Operating Temperature Range	0° C to +40° C (32° F to 104° F) <i>Battery performance may be reduced at very low temperatures</i>
Frequency Response	20 Hz to 20 kHz <i>Depending on microphone type</i>
Audio Sampling	24 bit / 48 kHz

#### RECEIVER

Receiving System	Diversity (frequency/time/space)
Maximum Output Level	1/4" (6.3 mm), TRS balanced: +12 dB
Power Supply	100-240V AC (50/60 Hz) to 12V DC 0.5A (center positive) switched mode external power supply
Dimensions	101 mm (3.98") W x 44 mm (1.73") H x 130 mm (5.12") D
Net Weight	565 grams (19.9 oz)
Accessory Included	Power supply, hook & loop fastener x2

#### UNIPAK® TRANSMITTER

RF Output Power	10 mW
Spurious Emissions	Following federal and national regulations
Input Connection	 Four-pin Locking Connector Pin 1: GND, Pin 2: INST INPUT, Pin 3: MIC INPUT, Pin 4: DC BIAS +9V
Batteries (not included)	Two 1.5V AA
Battery Life	>7 hours (alkaline) <i>Depending on battery type and use pattern</i>
Dimensions	70.2 mm (2.76") W x 107.0 mm (4.21") H x 24.9 mm (0.98") D
Net Weight (without batteries)	100 grams (3.5 oz)
Accessory Included	AT-GcW

<sup>1</sup> In the interest of standards development, A.T.U.S. offers full details on its test methods to other industry professionals on request.

---

## System 10 Stompbox Installation and Operation

---

To reduce the environmental impact of a multi-language printed document, product information is available online at [www.audio-technica.com](http://www.audio-technica.com) in a selection of languages.

Afin de réduire l'impact sur l'environnement de l'impression de plusieurs langues, les informations concernant les produits sont disponibles sur le site [www.audio-technica.com](http://www.audio-technica.com) dans une large sélection de langue.

Para reducir el impacto al medioambiente, y reducir la producción de documentos en varios legüjes, información de nuestros productos están disponibles en nuestra página del Internet: [www.audio-technica.com](http://www.audio-technica.com).

Para reduzir o impacto ecológico de um documento impresso de várias linguas, a Audio-Technica providência as informações dos seus produtos em diversas linguas na [www.audio-technica.com](http://www.audio-technica.com).

Per evitare l'impatto ambientale che la stampa di questo documento determinerebbe, le informazioni sui prodotti sono disponibili online in diverse lingue sul sito [www.audio-technica.com](http://www.audio-technica.com).

Der Umwelt zuliebe finden Sie die Produktinformationen in deutscher Sprache und weiteren Sprachen auf unserer Homepage: [www.audio-technica.com](http://www.audio-technica.com).

Om de gevolgen van een gedrukte meertalige handleiding op het milieu te verkleinen, is productinformatie in verschillende talen "on-line" beschikbaar op: [www.audio-technica.com](http://www.audio-technica.com).

本公司基於減少對環境的影響，將不作多語言文件的印刷，有關產品訊息可在 [www.audio-technica.com](http://www.audio-technica.com) 的官方網頁上選擇所屬語言及瀏覽。

本公司基于减少对环境的影响，将不作多语言文档的印刷，有关产品信息可在 [www.audio-technica.com](http://www.audio-technica.com) 的官方网页上选择所属语言和浏览。

자원절약, 환경보호를 위해 국문 사용 설명서는 인쇄하지 않았습니다.  
제품정보는 [www.audio-technica.com](http://www.audio-technica.com) 에서 원하는 언어 선택 후에 다운로드 받으실 수 있습니다.

