



MET Laboratories, Inc. *Safety Certification - EMI - Telecom Environmental Simulation*
914 WEST PATAPSCO AVENUE • BALTIMORE, MARYLAND 21230-3432 • PHONE (410) 354-3300 • FAX (410) 354-3313

October 16, 2006

Audio-Technica
20300 Century Boulevard, Suite 250
Germantown, MD 20874-1132

Dear Jacquelynn Green,

Enclosed is the EMC test report for compliance testing of the Audio-Technica, SpectraPulse Wireless Microphone System – Microphone Transceiver Unit (MTU101), tested to the requirements of Title 47 of the Code of Federal Regulations (CFR), Part 15.517, Subpart F for Ultra-Wideband Operation.

Based on these results, MET Laboratories, Inc. certifies that the SpectraPulse Wireless Microphone System – Microphone Transceiver Unit (MTU101), tested as configured, meets the requirements and interference limitations for Digital Devices under Title 47 of the CFR, Part 15.517, Subpart F for Ultra-Wideband Operation.

Thank you for using the services of MET Laboratories, Inc. If you have any questions regarding these results or if MET can be of further service to you, please feel free to contact me.

Sincerely yours,
MET LABORATORIES, INC.

Sarah Kitlowski
Documentation Department

Reference: (\Audio-Technica\EMC19886A-FCC517)

Certificates and reports shall not be reproduced except in full, without the written permission of MET Laboratories, Inc. While use of the National Voluntary Laboratory Accreditation Program (NVLAP) letters or the NVLAP Logo, the Standards Council of Canada Logo, A2LA, or the Nationally Recognized Testing Laboratory (NRTL) Letters in this report reflects MET Accreditation under these programs, these letters, logo, or statements do not claim product endorsement by these organizations or any Agency of the U.S. Government. This letter of transmittal is not a part of the attached report.



The Nation's First Licensed Nationally Recognized Testing Laboratory

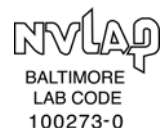



MET Laboratories, Inc. *Safety Certification - EMI - Telecom Environmental Simulation*
914 WEST PATAPSCO AVENUE • BALTIMORE, MARYLAND 21230-3432 • PHONE (410) 354-3300 • FAX (410) 354-3313

Electromagnetic Compatibility Criteria Test Report

For the

**Audio-Technica
SpectraPulse Wireless Microphone System – Microphone Transceiver Unit (MTU101)**

FCC ID: JFZMTU101

Verified under
the FCC Certification Rules contained in
Title 47 of the CFR, Part 15.517, Subpart F
for Ultra-Wideband Operation

MET Report: EMC19886A-FCC517

October 16, 2006

Prepared For:

**Audio-Technica
20300 Century Boulevard, Suite 250
Germantown, MD 20874-1132**

**Prepared By:
MET Laboratories, Inc.**
914 West Patapsco Avenue
Baltimore, MD 21230



**Electromagnetic Compatibility Criteria
Test Report**

for the

**Audio-Technica
SpectraPulse Wireless Microphone System – Microphone Transceiver Unit (MTU101)**

FCC ID: JFZMTU101

**Title 47 of the CFR, Part 15.517, Subpart F
for Ultra-Wideband Operation**

Dusmantha Tennakoon
Project Engineer, Electromagnetic Compatibility Lab

Sarah Kitlowski
Documentation Department

Engineering Statement: The measurements shown in this report were made in accordance with the procedures indicated, and the emissions from this equipment were found to be within the limits applicable. I assume full responsibility for the accuracy and completeness of these measurements, and for the qualifications of all persons taking them. It is further stated that upon the basis of the measurements made, the equipment tested is capable of operation in accordance with the requirements of Part 15, Section 15.517 of the FCC Rules under normal use and maintenance.

Kevin Mehaffey,
Manager, Electromagnetic Compatibility Lab



Table of Contents

I.	Executive Summary	1
	A. Purpose of Test	2
	B. Executive Summary	2
II.	Equipment Configuration	3
	A. Overview.....	4
	B. References.....	5
	C. Test Site	5
	D. Description of Test Sample.....	5
	E. Equipment Configuration.....	8
	F. Support Equipment	8
	G. Mode of Operation.....	9
	H. Method of Monitoring EUT Operation	9
	I. Modifications	9
	a) Modifications to EUT.....	9
	b) Modifications to Test Standard.....	9
	J. Frequency Determining Parameters.....	9
	K. Disposition of EUT	10
	L. Test Procedures.....	10
III.	Electromagnetic Compatibility Criteria for Intentional Radiators.....	11
	§ 15.203 Antenna Requirement	12
	§ 15.209(a) Radiated Emission Limits	15
	§ 15.517(b) Ultra-Wide Operation Bandwidth	22
	§ 15.517(c) Radiated Emission Limits	27
	§ 15.517(d) Radiated Emissions in GPS bands	31
	§ 15.517(e) Peak Emissions within a 50 MHz Bandwidth	34
IV.	Test Equipment	37
V.	Certification & User’s Manual Information.....	39
	A. Certification Information	40
	B. Label and User’s Manual Information	44



List of Tables

Table 1. Executive Summary of EMC Part 15.517 Compliance Testing	2
Table 2. EUT Overview	4
Table 3. Equipment Configuration	8
Table 4. Support Equipment.....	8
Table 5. Radiated Emissions Limits Calculated from FCC Part 15, § 15.209 (a)	15
Table 6. Radiated Emissions Test Results, 30 MHz – 1 GHz	16
Table 7. Radiated Emissions Test Results, 1 GHz – 40 GHz - Peak	17
Table 8. Radiated Emissions Test Results, 1 GHz – 40 GHz - Average	18
Table 9. Radiated Emission Requirements from §15.517(c).....	27
Table 10. Radiated Emissions Limits.....	28
Table 11. Radiated Emission Requirements from §15.517(d).....	31
Table 12. Results - Average Radiated Emissions - Narrowband at 1 meter.....	32
Table 13. Test Equipment	38

List of Figures

Figure 1. Block Diagram of EUT	6
Figure 2. Block Diagram of Test Configuration.....	7
Figure 3. Radiated Emissions Prescan.....	19
Figure 4. UWB Bandwidth, $f_M = 6.326$ GHz	23
Figure 5. UWB Bandwidth, $f_L = 5.610$ GHz.....	24
Figure 6. UWB Bandwidth, $f_H = 7.232$ GHz.....	25
Figure 7. Radiated Emission Limits Test Results, 3.1 GHz – 10.6 GHz.....	29
Figure 8. Peak Radiated Emissions Test Results.....	35
Figure 9. Radiated Emissions Test Setup.....	36

List of Photographs

Photograph 1. View of Antenna on EUT	13
Photograph 2. Second View of Antenna on EUT.....	14
Photograph 3. Radiated Emission Test Setup – 30 MHz to 1 GHz	20
Photograph 4. Radiated Emission Test Setup - above 1 GHz	21
Photograph 5. Radiated Emissions Test Setup	26
Photograph 6. Radiated Emissions Test Setup	30
Photograph 7. Radiated Emissions Test Setup	33



List of Terms and Abbreviations

AC	Alternating Current
ACF	Antenna Correction Factor
Cal	Calibration
<i>d</i>	Measurement Distance
dB	Decibels
dBμA	Decibels above one microamp
dBμV	Decibels above one microvolt
dBμA/m	Decibels above one microamp per meter
dBμV/m	Decibels above one microvolt per meter
DC	Direct Current
E	Electric Field
EUT	Equipment Under Test
<i>f</i>	Frequency
FCC	Federal Communications Commission
GRP	Ground Reference Plane
H	Magnetic Field
HCP	Horizontal Coupling Plane
Hz	Hertz
kHz	kilohertz
kV	kilovolt
LISN	Line Impedance Stabilization Network
MHz	Megahertz
μH	microhenry
μF	microfarad
μs	microseconds
PRF	Pulse Repetition Frequency
RF	Radio Frequency
RMS	Root-Mean-Square
TWT	Traveling Wave Tube
V/m	Volts per meter
VCP	Vertical Coupling Plane



I. Executive Summary



A. Purpose of Test

An EMC evaluation to determine compliance of the Audio-Technica, SpectraPulse Wireless Microphone System – Microphone Transceiver Unit (MTU101) with the requirements of Part 15, Subpart F, §15.517 was performed. All references are to the most current version of Title 47 of the Code of Federal Regulations in effect. In accordance with §2.1033, the following data is presented in support of the Certification of the Audio-Technica, SpectraPulse Wireless Microphone System – Microphone Transceiver Unit (MTU101). Audio-Technica should retain a copy of this document which should be kept on file for at least two years after the manufacturing of the SpectraPulse Wireless Microphone System – Microphone Transceiver Unit MTU101 has been **permanently** discontinued.

B. Executive Summary

The following tests were conducted on a sample of the equipment for the purpose of demonstrating compliance with Part 15, Subpart F, §15.517. All tests were conducted using measurement procedure ANSI C63.4-2003.

Reference	Description	Compliance
Title 47 of the CFR, Part 15, Subpart C, §15.203	Antenna Requirements	Compliant
Title 47 of the CFR, Part 15, Subpart C, §15.207 (a)	Conducted Emissions for Intentional Radiators	*N/A – EUT is battery powered
Title 47 of the CFR, Part 15, Subpart C, §15.209 (a)	Radiated Emissions for Intentional Radiators	Compliant
Title 47 of the CFR, Part 15, Subpart F, §15.517 (a)	Indoor Operation Limitation	Applicant has been advised of these requirements.
Title 47 of the CFR, Part 15, Subpart F, §15.517 (b)	10 dB UWB Bandwidth	Compliant
Title 47 of the CFR, Part 15, Subpart F, §15.517 (c)	Radiated Emissions Limits	Compliant
Title 47 of the CFR, Part 15, Subpart F, §15.517 (d)	Radiated Emissions Limits in GPS band	Compliant
Title 47 of the CFR, Part 15, Subpart F, §15.517 (e)	Peak Emissions within 50 MHz bandwidth	Compliant
Title 47 of the CFR, Part 15, Subpart F, §15.517 (f)	UWB Labeling Requirements	Applicant has been advised of these requirements

Table 1. Executive Summary of EMC Part 15.517 Compliance Testing

NOTE: Spread spectrum systems are sharing these bands on a noninterference basis with systems supporting critical Government requirements that have been allocated the usage of these bands, secondary only to ISM equipment operated under the provisions of part 18 of this chapter. Many of these Government systems are airborne radiolocation systems that emit a high EIRP which can cause interference to other users. Also, investigations of the effect of spread spectrum interference to U. S. Government operations in the 3100 – 10,600 MHz band may require a future decrease in the power limits allowed for spread spectrum operation.

* The EUT has charge contacts. However, a charger does not exist, at present. When one becomes available the customer intends to come back for conducted emissions.



II. Equipment Configuration



A. Overview

MET Laboratories, Inc. was contracted by Audio-Technica to perform testing on the SpectraPulse Wireless Microphone System – Microphone Transceiver Unit (MTU101), under Audio-Technica purchase order number JAG-21956.

This document describes the test setups, test methods, required test equipment, and the test limit criteria used to perform compliance testing of the Audio-Technica, SpectraPulse Wireless Microphone System – Microphone Transceiver Unit (MTU101).

The results obtained relate only to the item(s) tested.

Type of Submission/Rule:	Part 15.517 Original Filing
Model(s) Tested:	SpectraPulse Wireless Microphone System – Microphone Transceiver Unit (MTU101)
Model(s) Number:	SpectraPulse Wireless Microphone System – Microphone Transceiver Unit (MTU101)
EUT Specifications:	Primary Power: 3 Vdc
	UWB 10 dB Bandwidth: 1.622 GHz
	FCC ID: JFZMTU101
	Equipment Code: UWB
Lab Ambient (Normal) Test Conditions:	Temperature: 15-35° C
	Relative Humidity: 30-60%
	Atmospheric Pressure: 860-1060 mbar
Evaluated by:	Dusmantha Tennakoon
Date(s):	October 16, 2006

Table 2. EUT Overview



B. References

CFR 47, Part 2	Federal Communication Commission, Code of Federal Regulations, Title 47, Part 15: Frequency Allocations and Radio Treaty Matters; General Rules and Regulations
CFR 47, Part 15	Federal Communication Commission, Code of Federal Regulations, Title 47, Part 15: Radio Frequency Devices
ANSI C63.4-2003	Methods and Measurements of Radio-Noise Emissions from Low-Voltage Electrical And Electronic Equipment in the Range of 9 kHz to 40 GHz
ANSI/NCSL Z540-1-1994	Calibration Laboratories and Measuring and Test Equipment - General Requirements
ANSI/ISO/IEC 17025: 2000	General Requirements for the Competence of Testing and Calibration Laboratories

C. Test Site

All testing was performed at MET Laboratories, Inc., 914 West Patapsco Avenue, Baltimore, MD 21230. All equipment used in making physical determinations is accurate and bears recent traceability to the National Institute of Standards and Technology.

Radiated Emissions measurements were performed in a semi-anechoic chamber. In accordance with §2.948(a)(3), a complete site description is contained at MET Laboratories. In accordance with §2.948(d), MET Laboratories has been accredited by the National Voluntary Laboratory Accreditation Program (Lab Code: 100273-0).

D. Description of Test Sample

The SpectraPulse Wireless Microphone System – Microphone Transceiver Unit (MTU101), Equipment Under Test (EUT), is powered by 3 Vdc. The EUT is a wireless boundary microphone that transmits and receives via UWB signals. The intended use is as an (indoor) microphone in a sound reinforcement or recording situation.

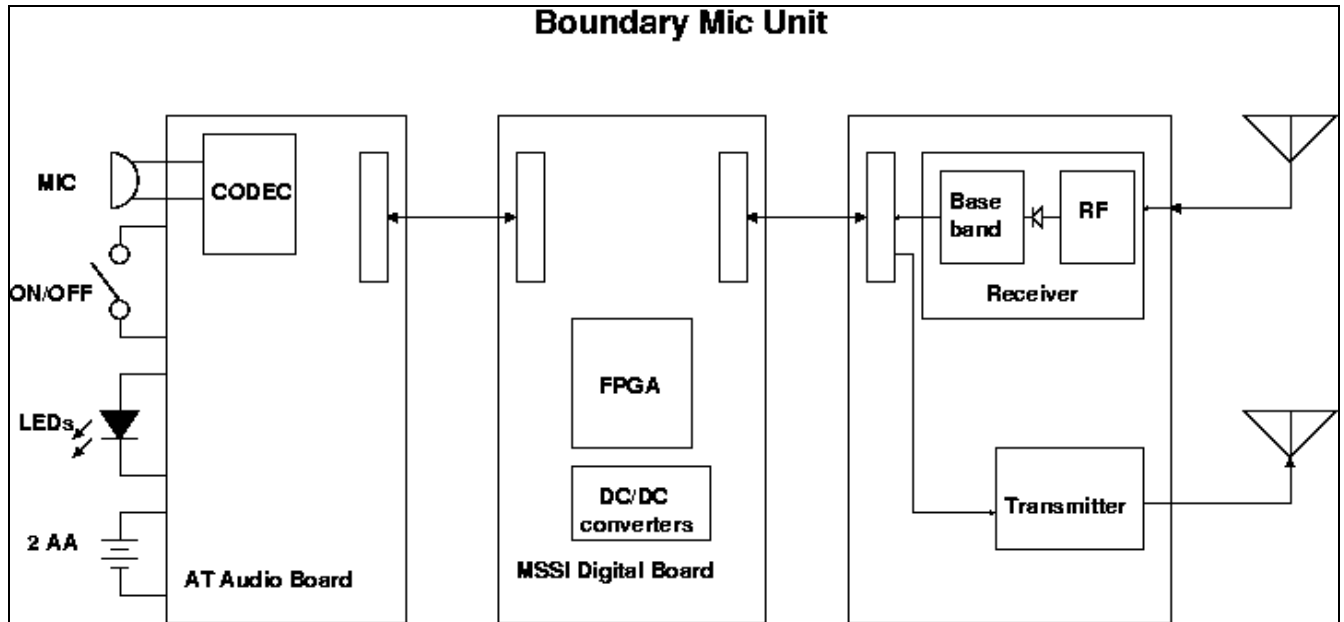

Figure 1. Block Diagram of EUT

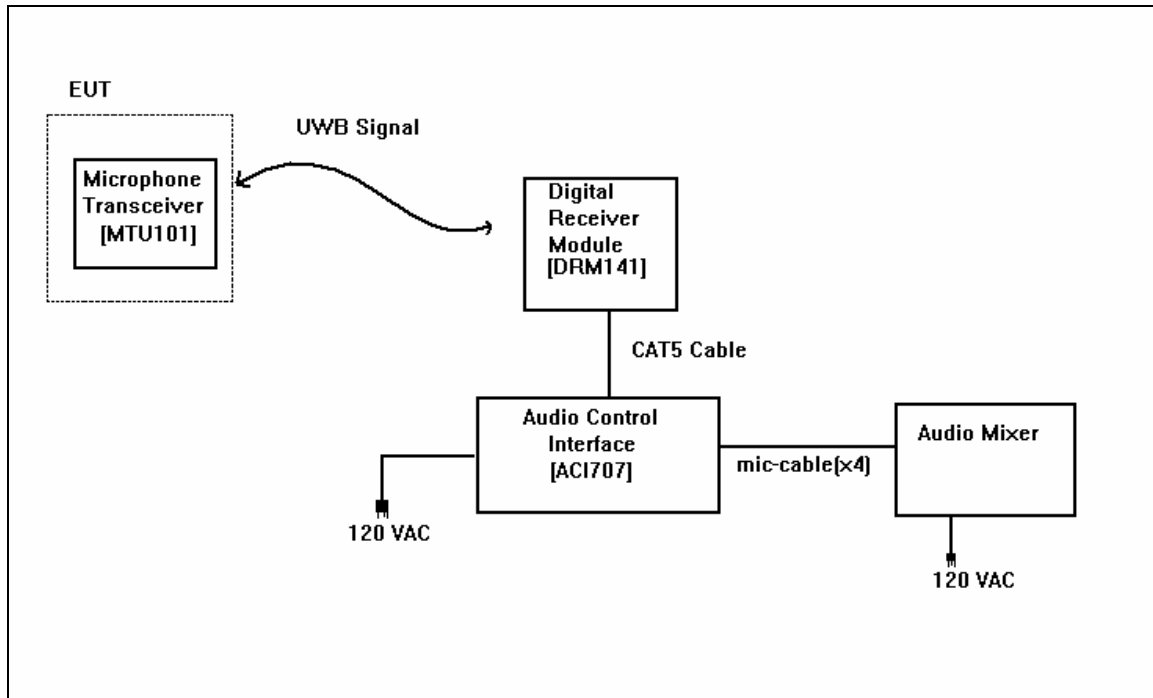

Figure 2. Block Diagram of Test Configuration

* The Audio Mixer is only used to verify the link between the MTU101 and DRM141.



E. Equipment Configuration

The EUT was set up as outlined in Figure 2. All equipment incorporated as part of the EUT is included in the following list.

Ref. ID	Name / Description	Model Number	Serial Number
1	Microphone transceiver	MTU101	1001

Table 3. Equipment Configuration

F. Support Equipment

Support equipment necessary for the operation and testing of the EUT is included in the following list.

Ref. ID	Name / Description	Model Number	Serial Number
2	Digital Receiver Module	DRM141	1003
4	Audio Control Interface	ACI707	1004

Table 4. Support Equipment



G. Mode of Operation

There is only one mode of operation. It is a closed loop system of transmit/receive at mic/antenna ends. From DRM141 to ACI707 the unit is hard-wired via CAT 5 cable.

H. Method of Monitoring EUT Operation

There is a link light on the MTU101 that will be lit when the unit is functioning properly. This light corresponds to a link light on the control interface – which is also lit when the system is functioning.

I. Modifications

a) Modifications to EUT

No modifications were made to the EUT.

b) Modifications to Test Standard

No modifications were made to the Test Standard.

J. Frequency Determining Parameters

The highest frequency employed in §15.33 to determine the frequency range over which radiated emissions are made was based on the center frequency, f_c , unless a higher frequency was generated within the UWB device. For measuring emission levels, the spectrum was investigated from the lowest frequency generated in the UWB, without going below 9 kHz, up to the frequency range shown in Section 15.33(a) of the CFR 47 or up to $f_c + 3/(\text{pulse width in seconds})$, whichever was higher. There is no requirement to measure emissions beyond 40 GHz provided f_c was less than 10 GHz; beyond 100 GHz if f_c was at or above 10 GHz and below 30 GHz; or beyond 200 GHz if f_c was at or above 30 GHz.

$$f_c = (f_L + f_h)/2 = 6.421 \text{ GHz}$$

$$f_M = 6.326 \text{ GHz}$$

$$\text{Pulse width} = 2\text{ns}$$

Therefore, the highest frequency to be measured was 40 GHz.



K. Disposition of EUT

The test sample including all support equipment (if any), submitted to the Electro-Magnetic Compatibility Lab for testing was returned to Audio-Technica upon completion of testing.

L. Test Procedures

1. FCC's UWB guidance was followed when making field strength of radiated emissions.
2. The orientation of the EUT was adjusted during testing when making field strength measurements.
3. There is no continuous pulse stream which is gated, thus it is meaningless (and actually impossible) to operate the device with the "pulse train gated on." The system operates in a time-division multiplex fashion where long transmissions are scheduled in a round-robin fashion.



III. Electromagnetic Compatibility Criteria for Intentional Radiators



Electromagnetic Compatibility Criteria for Intentional Radiators

§ 15.203 Antenna Requirement

Test Requirement: § 15.203: An intentional radiator shall be designed to ensure that no antenna other than that furnished by the responsible party shall be used with the device. The use of a permanently attached antenna or of an antenna that uses a unique coupling to the intentional radiator shall be considered sufficient to comply with the provisions of this section. The manufacturer may design the unit so that a broken antenna can be replaced by the user, but the use of a standard antenna jack or electrical connector is prohibited.

The structure and application of the EUT were analyzed to determine compliance with Section 15.203 of the Rules. Section 15.203 states that the subject device must meet at least one of the following criteria:

- a.) Antenna must be permanently attached to the unit.
- b.) Antenna must use a unique type of connector to attach to the EUT.
- c.) Unit must be professionally installed. Installer shall be responsible for verifying that the correct antenna is employed with the unit.

Results: The EUT was compliant with the requirements of this section. The antenna is permanently mounted and is not user accessible. See photograph 1 and 2 for pictures of antenna.

Type of Antenna: Vertical

Gain of Antenna: 4.3 dBi (max)

Test Engineer(s): Dusmantha Tennakoon

Test Date(s): 7/14/06



Photograph 1. View of Antenna on EUT



Photograph 2. Second View of Antenna on EUT



Electromagnetic Compatibility Criteria for Intentional Radiators

§ 15.209(a) Radiated Emission Limits

Test Requirement(s): § 15.209 (a): Except as provided elsewhere in this subpart, the emissions from an intentional radiator shall not exceed the field strength levels specified in Table 5.

Frequency (MHz)	§ 15.209(a), Radiated Emission Limits (dB μ V/m) @ 3m
30 - 88	40.00
88 - 216	43.50
216 - 960	46.00
Above 960	Refer to section 15.517(c)

Table 5. Radiated Emissions Limits Calculated from FCC Part 15, § 15.209 (a)

Test Procedure: The transmitter was set to transmit at maximum output power and placed on a 0.8 m high acrylic table inside in a semi-anechoic chamber. The antenna was located 3 m from the EUT. Measurements were performed with the EUT rotated 360 degrees and varying the receiving antenna height from 1 to 4 meters to determine worst case orientation for maximum emissions.

For frequencies from 30 MHz to 1 GHz, measurements were made using a quasi-peak detector with a 120 kHz bandwidth. For frequencies above 1 GHz, peak measurements were made with a resolution bandwidth of 1 MHz and a video bandwidth of 3 MHz and average measurements were made with RMS detector.

For intentional radiators with a digital device portion which operates below 10 GHz, the spectrum was investigated as per §15.33(a)(1) and §15.33(a)(4); i.e., the lowest RF signal generated or used in the device up to the 10th harmonic of the highest fundamental frequency or to 40 GHz, whichever is lower.

In accordance with §15.35(b) the limit on the radio frequency emissions as measured using instrumentation with a peak detector function shall be 20 dB above the maximum permitted average limit for the frequency being investigated unless a different peak emission limit is otherwise specified in the rules.

Test Results: The emissions were investigated up to 40 GHz. The EUT was found compliant with the Radiated Emission limits of §15.209 for Intentional Radiators. See following pages for detailed test results.

Test Engineer(s): Dusmantha Tennakoon

Test Date(s): 7/20/06



Electromagnetic Compatibility Criteria for Intentional Radiators

§ 15.209(a) Radiated Emission

Frequency (MHz)	EUT Azimuth (Degrees)	Antenna Polarity (H/V)	Antenna HEIGHT (m)	Uncorrected Amplitude (dBuv)	Antenna Correction Factor (dB) (+)	Cable Loss (dB) (+)	Distance Correction Factor (dB) (-)	Corrected Amplitude (dBuv)	Limit (dBuv)	Margin (dB)
36.857	360	H	2.16	20.56	7.82	0.49	0.00	28.87	40.00	-11.13
36.857*	125	V	1.00	29.49	7.85	0.49	0.00	37.83	40.00	-2.17
67.581	360	H	1.00	17.50	9.89	0.67	0.00	28.06	40.00	-11.94
67.581	124	V	1.00	24.26	9.32	0.67	0.00	34.25	40.00	-5.75
98.301	199	H	2.54	23.99	7.80	0.79	0.00	32.58	43.50	-10.92
98.301	123	V	1.28	27.90	8.03	0.79	0.00	36.72	43.50	-6.78
270.330	66	H	2.36	20.42	12.11	1.40	0.00	33.94	46.00	-12.06
270.330	338	V	1.76	24.17	11.61	1.40	0.00	37.18	46.00	-8.82
270.330	339	H	2.39	20.42	12.11	1.40	0.00	33.94	46.00	-12.06
270.330	0	V	1.84	24.26	11.61	1.40	0.00	37.27	46.00	-8.73
294.914	305	H	3.78	23.52	13.20	1.44	0.00	38.16	46.00	-7.84
294.914	17	V	2.51	25.72	12.60	1.44	0.00	39.76	46.00	-6.24
344.070	59	H	1.36	16.69	14.34	1.60	0.00	32.63	46.00	-13.37
344.070	263	V	1.00	21.58	14.80	1.60	0.00	37.98	46.00	-8.02

Table 6. Radiated Emissions Test Results, 30 MHz – 1 GHz

Note 1: * - At this frequency, the measured electric-field strength exhibits a margin of compliance that is less than 3 dB below the specification limit. We recommend that every emission measured, have at least a 3 dB margin to allow for deviations in the emission characteristics that may occur during the production process.

Note 2: The EUT was tested at 3 m.



Electromagnetic Compatibility Criteria for Intentional Radiators

§ 15.209(a) Radiated Emission

Frequency (GHz)	EUT Azimuth (Degrees)	Antenna Polarity (H/V)	Antenna HEIGHT (m)	Uncorrected Amplitude (dBuv)	Antenna Correction Factor (dB) (+)	System Gain (dB) (-)	Distance Correction Factor (dB) (-)	Corrected Amplitude (dBuv)	Limit (dBuv)	Margin (dB)
1.048	0	H	1.00	39.67	24.55	27.97	9.54	26.72	74.00	-47.28
1.063	0	V	1.00	39.75	24.33	27.96	9.54	26.58	74.00	-47.42
1.063	0	H	1.00	40.48	24.33	27.96	9.54	27.31	74.00	-46.69
1.087	0	H	1.00	37.91	24.68	27.94	9.54	25.11	74.00	-48.89
1.128	0	V	1.00	39.99	24.56	27.92	9.54	27.09	74.00	-46.91
1.131	0	H	1.00	42.53	24.82	27.91	9.54	29.89	74.00	-44.11

Table 7. Radiated Emissions Test Results, 1 GHz – 40 GHz - Peak

Note: 1. The EUT was tested at 1 m.
2. No other emissions were found.



Electromagnetic Compatibility Criteria for Intentional Radiators

§ 15.209(a) Radiated Emission

Frequency (GHz)	EUT Azimuth (Degrees)	Antenna Polarity (H/V)	Antenna HEIGHT (m)	Uncorrected Amplitude (dBuv)	Antenna Correction Factor (dB) (+)	System Gain (dB) (-)	Distance Correction Factor (dB) (-)	Corrected Amplitude (dBuv)	Limit (dBuv)	Margin (dB)
1.048	0	H	1.00	28.11	24.55	27.97	9.54	15.16	54.00	-38.84
1.063	0	V	1.00	29.25	24.33	27.96	9.54	16.08	54.00	-37.92
1.063	0	H	1.00	30.22	24.33	27.96	9.54	17.05	54.00	-36.95
1.087	0	H	1.00	28.18	24.68	27.94	9.54	15.38	54.00	-38.62
1.128	0	V	1.00	28.67	24.56	27.92	9.54	15.77	54.00	-38.23
1.131	0	H	1.00	29.01	24.82	27.91	9.54	16.37	54.00	-37.63

Table 8. Radiated Emissions Test Results, 1 GHz – 40 GHz - Average

- Note:
1. The EUT was tested at 1 m.
 2. No other emissions were found.

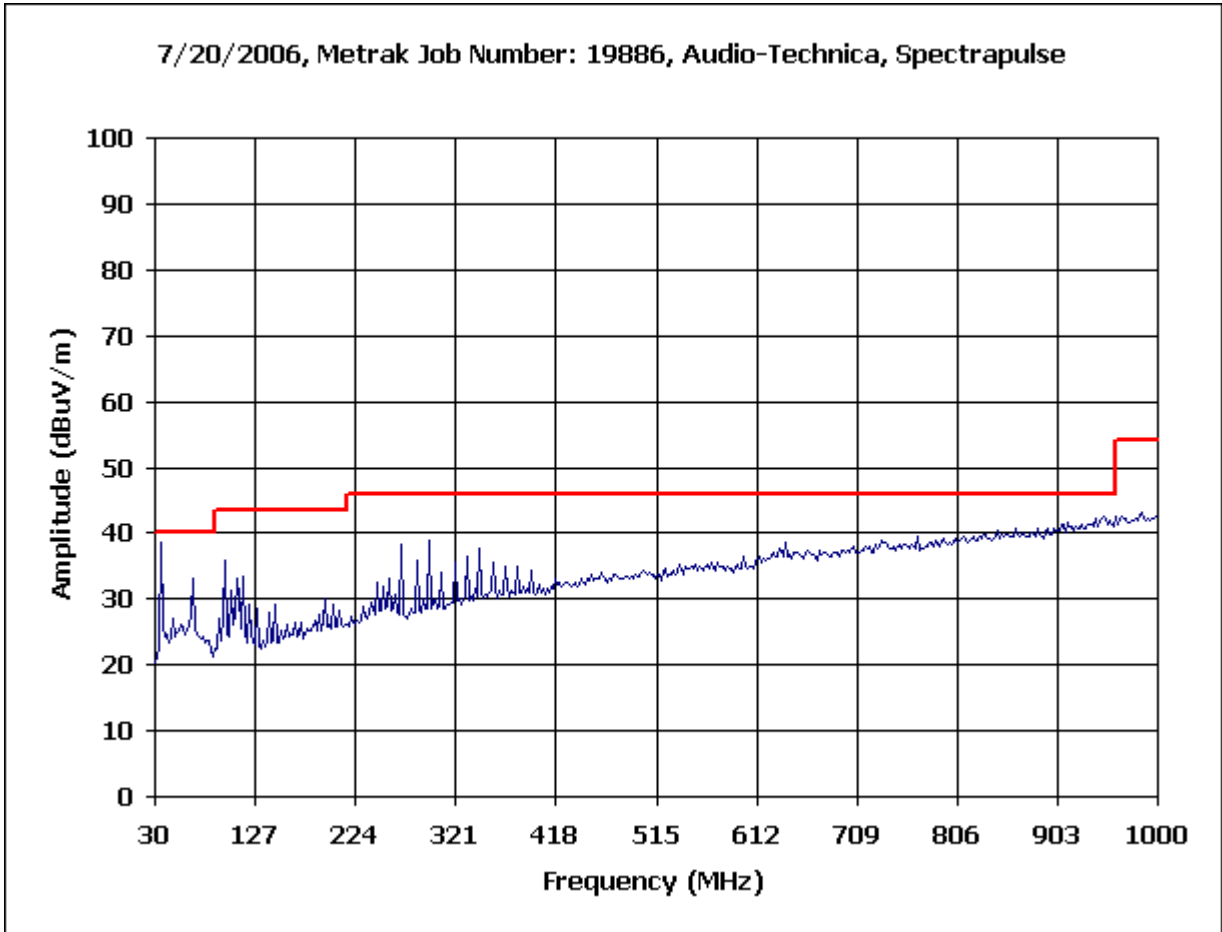
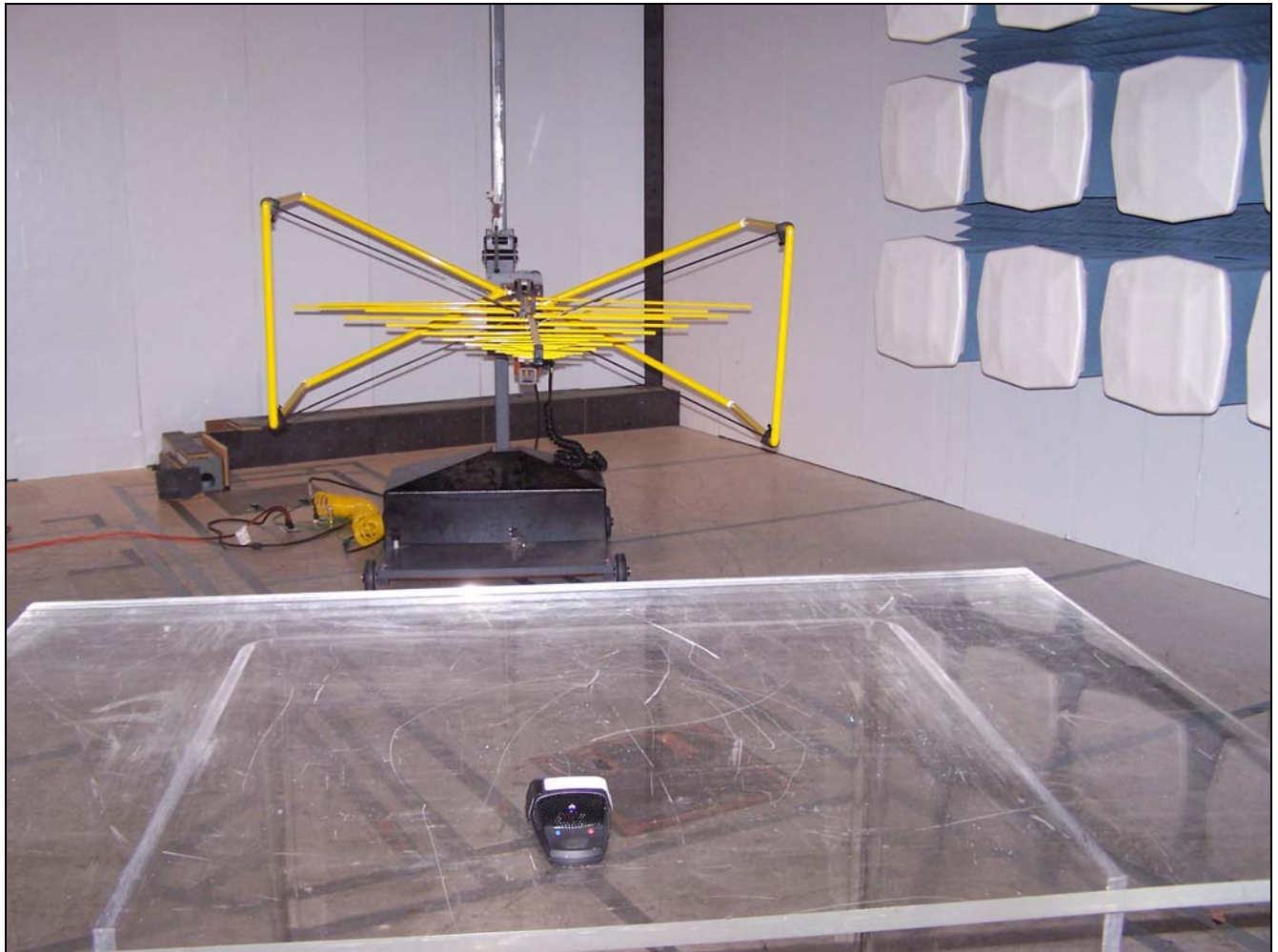

Figure 3. Radiated Emissions Prescan

Remarks: The EUT meets the specifications of **Section 15.209(a)** for Radiated Emissions of Intentional Radiators.

Electromagnetic Compatibility Criteria for Intentional Radiators

§ 15.209(a) Radiated Emission



Photograph 3. Radiated Emission Test Setup – 30 MHz to 1 GHz



Photograph 4. Radiated Emission Test Setup - above 1 GHz



Electromagnetic Compatibility Criteria for Intentional Radiators

§ 15.517(b) Ultra-Wide Operation Bandwidth

- Test Requirements:** § 15.517(b): The UWB bandwidth of a UWB system operating under the provisions of this section must be contained between 3100 MHz and 10,600 MHz.
- § 15.503(a): The UWB bandwidth should be measured by the points that are 10 dB below the highest radiated emission, as based on the complete transmission system including the antenna.
- § 15.503(d): An intentional radiator that, at any point in time, has a fractional bandwidth equal to or greater than 0.20 or has UWB bandwidth equal to or greater than 500 MHz, regardless of the fractional bandwidth.
- Test Procedure:** The transmitter was set to transmit at maximum output power and placed on a 1 m high wooden stand inside in a semi-anechoic chamber. The antenna was located 1 meter from the EUT. Measurements were performed with the EUT rotated 360 degrees and varying the receiving antenna height to determine worst case orientation for maximum emissions. The bandwidth of the fundamental frequency was measured with the spectrum analyzer using a RBW = 8 MHz and VBW = 50 MHz. The 10 dB bandwidth was measured and recorded. During initial measurements a wider spectrum was looked at to make sure that the emission does not increase in power above the first 10dB points. The bandwidth was reduced when making the final measurements for better resolution.
- Test Results:** The EUT was found compliant with the Radiated Emission limits of §15.517(b). See following pages for detailed test results: 10dB Bandwidth = 1.622 GHz, $f_L = 5.610$ GHz, $f_H = 7.232$ GHz and $f_M = 6.326$ GHz.
- Note: Antenna correction factor, cable loss and pre-amp gain have been corrected for in the SA.
- Test Engineer:** Dusmantha Tennakoon
- Test Date(s):** 5/25/06



Electromagnetic Compatibility Criteria for Intentional Radiators

§ 15.517(b) 10 dB UWB Bandwidth

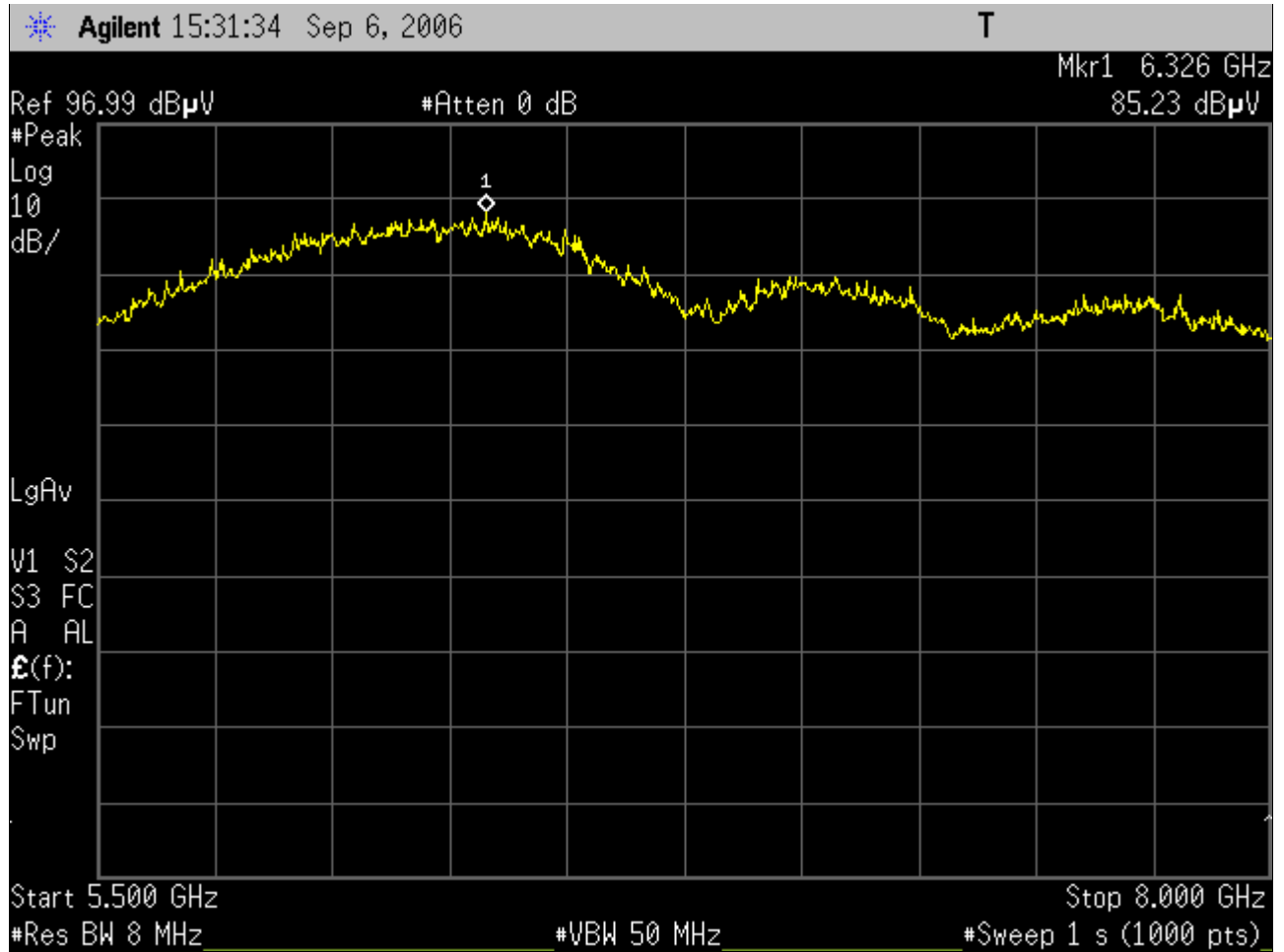

Figure 4. UWB Bandwidth, $f_M = 6.326$ GHz

Electromagnetic Compatibility Criteria for Intentional Radiators

§ 15.517(b) 10 dB UWB Bandwidth

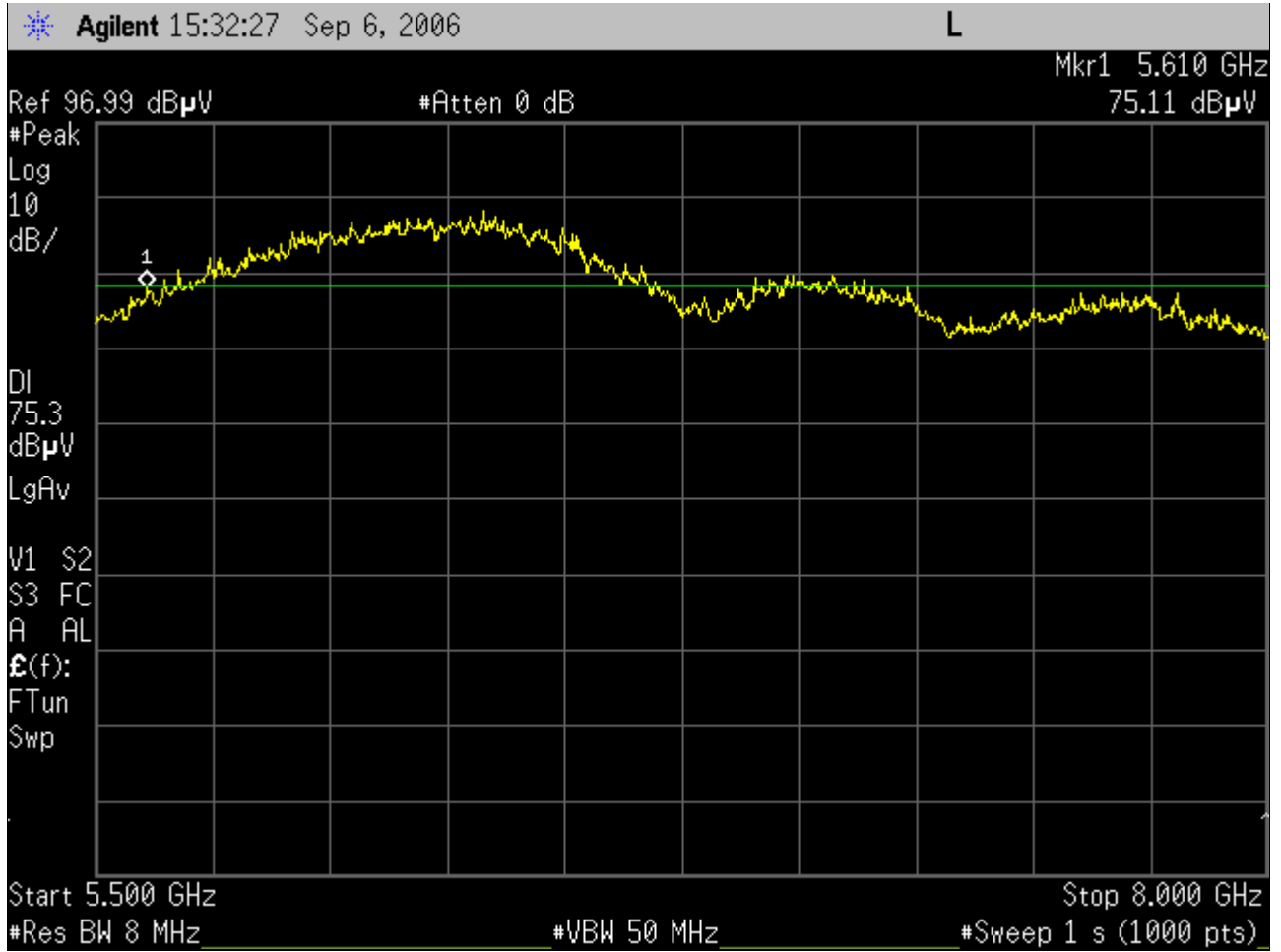

Figure 5. UWB Bandwidth, $f_L = 5.610$ GHz



Electromagnetic Compatibility Criteria for Intentional Radiators

§ 15.517(b) 10 dB UWB Bandwidth

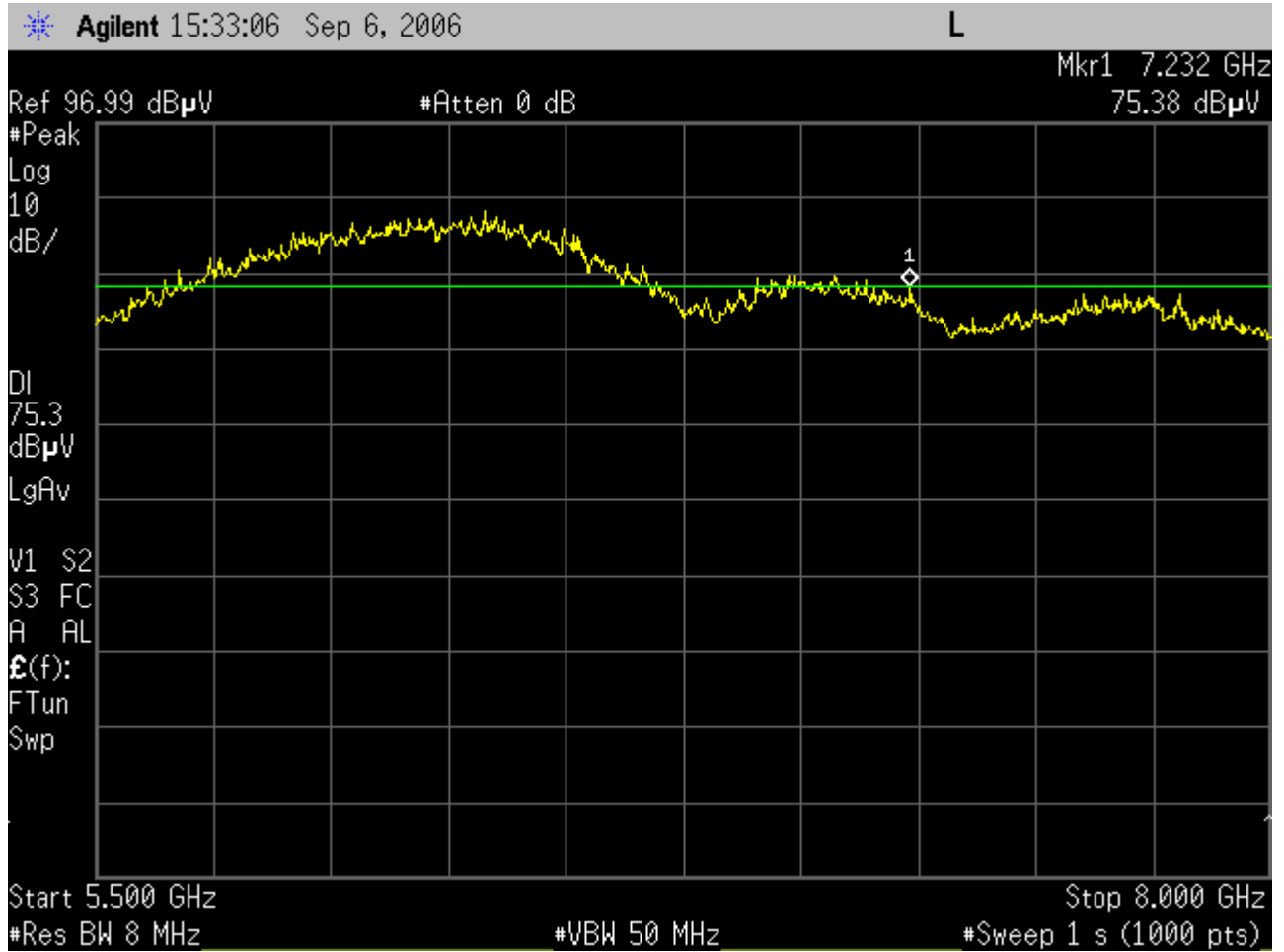

Figure 6. UWB Bandwidth, $f_H = 7.232$ GHz



Photograph 5. Radiated Emissions Test Setup



Electromagnetic Compatibility Criteria for Intentional Radiators

§ 15.517(c) Radiated Emission Limits

Test Requirements: §15.517(c): The radiated emissions at or below 960 MHz from a device operating under the provisions of this section shall not exceed the emission levels in §15.209. The radiated emissions above 960 MHz from a device operating under the provisions of this section shall not exceed the following average limits when measured using a resolution bandwidth of 1 MHz:

Frequency in MHz	EIRP in dBm
960 – 1610	- 75.3
1610 – 1990	- 53.3
1990 – 3100	- 51.3
3100 – 10600	- 41.3
Above 10600	- 51.3

Table 9. Radiated Emission Requirements from §15.517(c)

Note: A RMS detector was used for measurements above 960 MHz.

Test Limits: Calculation of Limit:

Avg EIRP Limit = -41.3 dBm.

The equivalent field strength at 3m = (-41.3) + 95.2 = 53.9 dB μ V/m

Test Results: The EUT was found compliant with the Radiated Emission limits of §15.517. See following pages for detailed test results for measurements above 960 MHz and for below 960 MHz.

Test Engineer: Dusmantha Tennakoon

Test Date(s): 5/31/06



Electromagnetic Compatibility Criteria for Intentional Radiators

§ 15.517(c) Radiated Emission Limits

Frequency (GHz)	EUT Azimuth (Degrees)	Antenna Polarity (H/V)	Antenna Height (m)	Measured at 1m dB μ V	Distance Correction Factor (dB) (-)	Corrected Amplitude (dB μ v)	Limit (dB μ v)	Margin (dB)
6.426	0	V	1	60.94	9.54	51.4	53.9	-2.5

Table 10. Radiated Emissions Limits

Note: No other emissions were detected except for the one shown above which is the highest in the 3100 – 10600 MHz band.



Electromagnetic Compatibility Criteria for Intentional Radiators

§ 15.517(c) Radiated Emission Limits

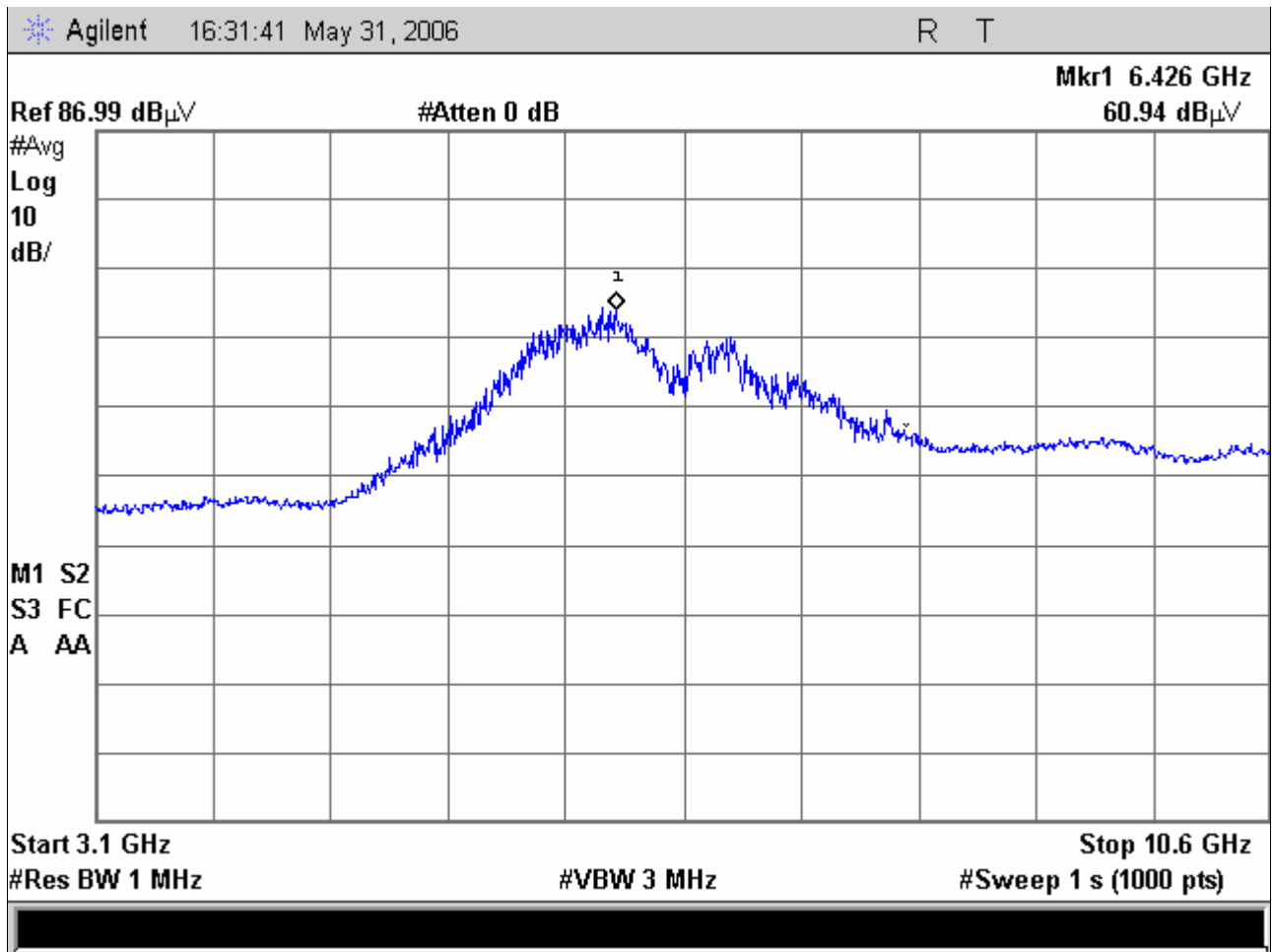

Figure 7. Radiated Emission Limits Test Results, 3.1 GHz – 10.6 GHz



Photograph 6. Radiated Emissions Test Setup



Electromagnetic Compatibility Criteria for Intentional Radiators

§ 15.517(d) Radiated Emissions in GPS bands

Test Requirements: §15.517(d): In addition to the radiated emission limits specified in the table in paragraph (c) of this section, UWB transmitters operating under the provisions of this section shall not exceed the following average limits when measured using a resolution bandwidth of no less than 1 kHz:

Frequency in MHz	EIRP in dBm
1164 – 1240	– 85.3
1559 – 1610	– 85.3

Table 11. Radiated Emission Requirements from §15.517(d)

Test Procedure: The transmitter was set to transmit at maximum output power and placed on a 1 m high wooden stand inside a semi-anechoic chamber. The antenna was located 1 m away from the EUT. Measurements were performed with the EUT rotated 360 degrees and varying the receiving antenna height to determine worst case orientation for maximum emissions. Tests were performed with vertical and horizontal polarization.

Average measurements were made with RMS detector activated on the spectrum analyzer and having the resolution bandwidth set to 1 kHz and video bandwidth set to 10 kHz.

Calculation of Limit: The EIRP limit is mathematically converted to the equivalent 3 m field strength using the following equation from §15.521(g): $E(\text{dBuV/m}) = P(\text{dBm EIRP}) + 95.2$

Test Results: The EUT was found compliant with the requirements of this section. See following pages for detailed test results.

Test Engineer: Dusmantha Tennakoon

Test Date: 5/25/06



Frequency (GHz)	EUT Azimuth (Degrees)	Antenna Polarity (H/V)	Antenna Height (m)	Uncorrected Amplitude (dBuv)	Distance Correction Factor (dB) (-)	Corrected Amplitude (dBuv)	Limit (dBuv)	Margin (dB)
1.179641	0	V	1	17.71	9.54	8.17	9.9	*-1.73
1.191929	0	V	1	13.51	9.54	3.97	9.9	*-5.93
1.204217	0	V	1	16.83	9.54	7.29	9.9	*-2.61
1.234938	0	V	1	15.77	9.54	6.23	9.9	*-3.67
1.560567	0	V	1	23.5	9.54	13.96	9.9	*4.06
1.585143	0	V	1	21.11	9.54	11.57	9.9	*1.67
1.603576	0	V	1	16.27	9.54	6.73	9.9	*-3.17

Table 12. Results - Average Radiated Emissions - Narrowband at 1 meter

*Note: None of these emissions were from the transmitter. They are from the digital portion of the transmitter. To verify this the wall transceiver (DRM141) was disconnected causing the EUT to stop transmitting. This was evident by the flashing red LED on the EUT. At this point only the digital portion is active. The emissions were still visible. Therefore, the emissions do not fall under this subtask. These emissions should fall under FCC Class B limits. These emissions are well within these limits.



Photograph 7. Radiated Emissions Test Setup



Electromagnetic Compatibility Criteria for Intentional Radiators

§ 15.517(e) Peak Emissions within a 50 MHz Bandwidth

Test Requirements: §15.517(e): The peak level of the emissions contained within a 50 MHz bandwidth centered on the frequency at which the highest radiated emission occurs, f_M . That limit is 0 dBm EIRP. It is acceptable to employ a different resolution bandwidth, and a correspondingly different peak emission limit, following the procedures described in §15.521.

§15.517(g): If a resolution bandwidth other than 50 MHz is employed, the peak EIRP limit shall be $20 \log (RBW/50)$ dBm where RBW is the resolution bandwidth in megahertz that is employed.

Test Procedure: The transmitter was set to transmit at maximum output power and placed on a 1 m high wooden stand inside a semi-anechoic chamber. The antenna was located 1 m away from the EUT. Measurements were performed with the EUT rotated 360 degrees and varying the receiving antenna height to determine worst case orientation for maximum emissions. Tests were performed with vertical and horizontal polarization.

The E-field strength level were converted from $\text{dB}\mu\text{V}/\text{m}$ to dBm, EIRP, in accordance with §15.521 (g). The equation used is $P(\text{dBm EIRP}) = E(\text{dB}\mu\text{V}/\text{m}) - 95.2$.

Measurements were made with PEAK detector activated to the spectrum analyzer and having the resolution bandwidth set to 8 MHz and video bandwidth set to 50 MHz.

Therefore, the limit calculated is $20 \log (8/50) = -15.92$ dBm.

The equivalent field strength at 3m = $-15.92+95.2$
= 79.28 $\text{dB}\mu\text{V}$

Test Results: The EUT was found compliant with the Radiated Emission limits of §15.517(e). See following pages for detailed test results.

Frequency (GHz)	EUT Azimuth (Degrees)	Antenna Polarity (H/V)	Antenna Height (m)	Measured Value @ 1m ($\text{dB}\mu\text{V}$)	Distance Correction Factor	Corrected Amplitude ($\text{dB}\mu\text{V}$)	Limit ($\text{dB}\mu\text{V}$)	Margin (dB)
6.326	0	V	1	85.23	9.54	75.69	79.28	-3.59

Test Engineer: Dusmantha Tennakoon

Test Date: May 24-25, 2006



Electromagnetic Compatibility Criteria for Intentional Radiators

§ 15.517(e) Peak Emissions within a 50 MHz Bandwidth

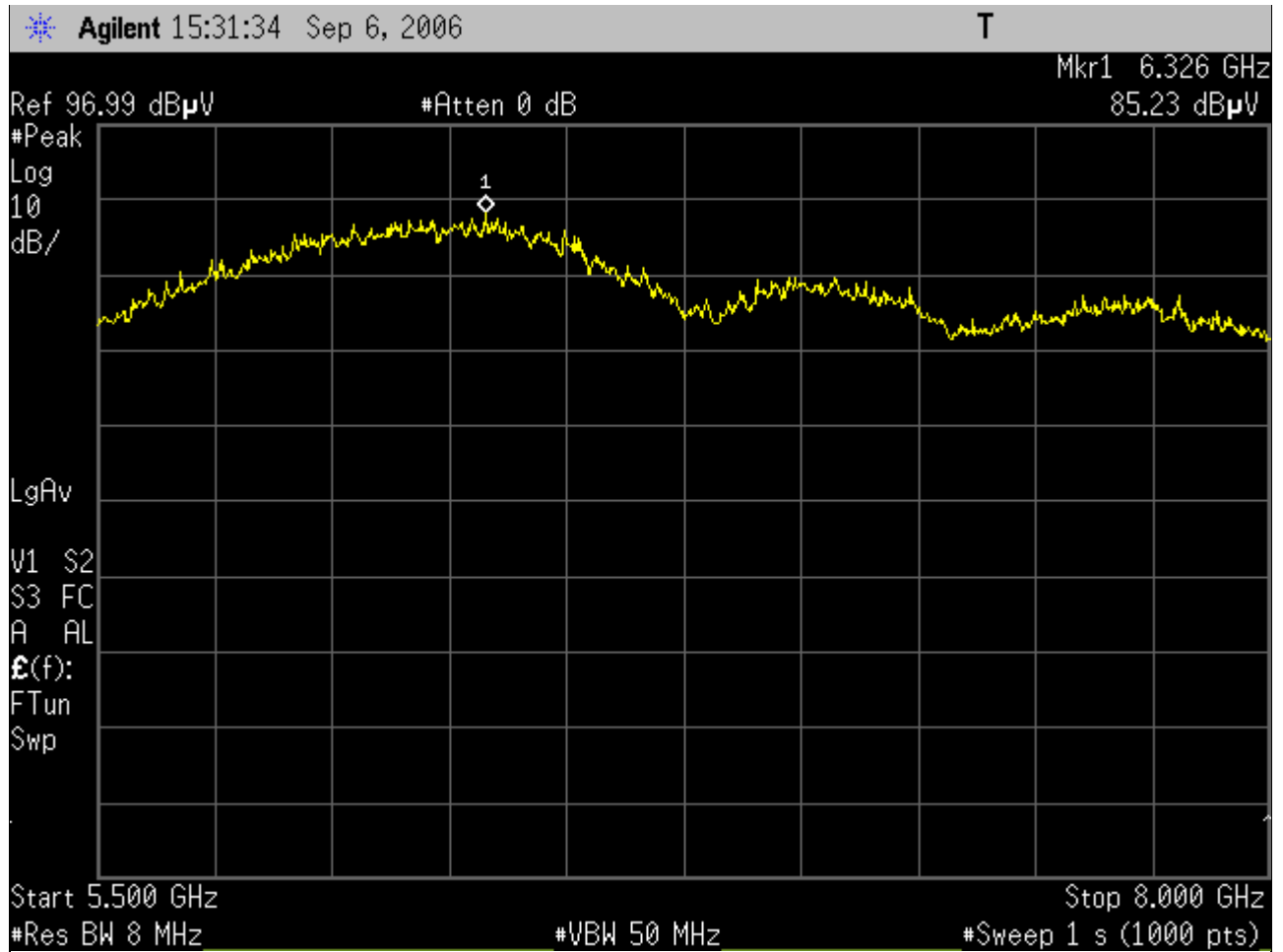

Figure 8. Peak Radiated Emissions Test Results



Figure 9. Radiated Emissions Test Setup



IV. Test Equipment



Test Equipment

Calibrated test equipment utilized during testing was maintained in a current state of calibration per the requirements of ANSI/NCSL Z540-1-1994 and ANSI/ISO/IEC 17025:2000.

TEST SECTIONS: FCC SUBPART F - 15.517			TEST DATE(S): 5/24/06 – 7/14/06		
MET ASSET #	NOMENCLATURE	MANUFACTURER	MODEL	LAST CAL DATE	CAL DUE DATE
1T4554	THERMO-HYGROMETER	CONTROL COMPANY	56-627-9	04/11/2006	04/11/2008
1T4409	EMI RECEIVER	ROHDE & SCHWARTZ	ESIB7	04/21/2006	04/21/2007
1T4300	SEMI-ANECHOIC CHAMBER # 1	EMC TEST SYSTEMS	NONE	02/17/2006	01/17/2009
1T4303	ANTENNA; BILOG	SCHAFNER - CHASE EMC	CBL6140A	06/20/2006	06/20/2007
1T2511	ANTENNA, HORN	EMCO	3115	06/28/2005	06/28/2006
1T2511	ANTENNA, HORN	EMCO	3115	07/13/2006	07/13/2007
1T4414	MICROWAVE PRE-AMPLIFIER	AH SYSTEMS	PAM-0118	SEE NOTE	
1T4442	MICROWAVE PRE-AMPLIFIER	MITEQ	AFS42-01001800	SEE NOTE	
N/A	PSA SPECTRUM ANALYZER	AGILENT	E4448A (US42070103)	01/12/2006	01/12/2007

Table 13. Test Equipment

Note: Functionally tested equipment is verified using calibrated instrumentation at the time of testing.



V. Certification & User's Manual Information



Certification & User's Manual Information

A. Certification Information

The following is extracted from Title 47 of the Code of Federal Regulations, Part 2, Subpart I — Marketing of Radio frequency devices:

§ 2.801 Radio-frequency device defined.

As used in this part, a radio-frequency device is any device which in its operation is capable of Emitting radio-frequency energy by radiation, conduction, or other means. Radio- frequency devices include, but are not limited to:

- (a) The various types of radio communication transmitting devices described throughout this chapter.
- (b) *The incidental, unintentional and intentional radiators defined in Part 15 of this chapter.*
- (c) The industrial, scientific, and medical equipment described in Part 18 of this chapter.
- (d) Any part or component thereof which in use emits radio-frequency energy by radiation, conduction, or other means.

§ 2.803 Marketing of radio frequency devices prior to equipment authorization.

- (a) Except as provided elsewhere in this chapter, no person shall sell or lease, or offer for sale or lease (including advertising for sale or lease), or import, ship or distribute for the purpose of selling or leasing or offering for sale or lease, any radio frequency device unless:
 - (1) In the case of a device subject to certification, such device has been authorized by the Commission in accordance with the rules in this chapter and is properly identified and labeled as required by §2.925 and other relevant sections in this chapter; or
 - (2) In the case of a device that is not required to have a grant of equipment authorization issued by the Commission, but which must comply with the specified technical standards prior to use, such device also complies with all applicable administrative (including verification of the equipment or authorization under a Declaration of Conformity, where required), technical, labeling and identification requirements specified in this chapter.
- (d) Notwithstanding the provisions of paragraph (a) of this section, the offer for sale solely to business, commercial, industrial, scientific or medical users (but not an offer for sale to other parties or to end users located in a residential environment) of a radio frequency device that is in the conceptual, developmental, design or pre-production stage is permitted prior to equipment authorization or, for devices not subject to the equipment authorization requirements, prior to a determination of compliance with the applicable technical requirements *provided* that the prospective buyer is advised in writing at the time of the offer for sale that the equipment is subject to the FCC rules and that the equipment will comply with the appropriate rules before delivery to the buyer or to centers of distribution.



- (e)(1) Notwithstanding the provisions of paragraph (a) of this section, prior to equipment authorization or determination of compliance with the applicable technical requirements any radio frequency device may be operated, but not marketed, for the following purposes and under the following conditions:
- (i) *Compliance testing;*
 - (ii) Demonstrations at a trade show provided the notice contained in paragraph (c) of this section is displayed in a conspicuous location on, or immediately adjacent to, the device;
 - (iii) Demonstrations at an exhibition conducted at a business, commercial, industrial, scientific or medical location, but excluding locations in a residential environment, provided the notice contained in paragraphs (c) or (d) of this section, as appropriate, is displayed in a conspicuous location on, or immediately adjacent to, the device;
 - (iv) Evaluation of product performance and determination of customer acceptability, provided such operation takes place at the manufacturer's facilities during developmental, design or pre-production states; or
 - (v) Evaluation of product performance and determination of customer acceptability where customer acceptability of a radio frequency device cannot be determined at the manufacturer's facilities because of size or unique capability of the device, provided the device is operated at a business, commercial, industrial, scientific or medical user's site, but not at a residential site, during the development, design or pre-production stages.
- (e)(2) For the purpose of paragraphs (e)(1)(iv) and (e)(1)(v) of this section, the term *manufacturer's facilities* includes the facilities of the party responsible for compliance with the regulations and the manufacturer's premises, as well as the facilities of other entities working under the authorization of the responsible party in connection with the development and manufacture, but not the marketing, of the equipment.
- (f) For radio frequency devices subject to verification and sold solely to business, commercial, industrial, scientific and medical users (excluding products sold to other parties or for operation in a residential environment), parties responsible for verification of the devices shall have the option of ensuring compliance with the applicable technical specifications of this chapter at each end user's location after installation, provided that the purchase or lease agreement includes a proviso that such a determination of compliance be made and is the responsibility of the party responsible for verification of the equipment.



Certification & User's Manual Information

The following is extracted from Title 47 of the Code of Federal Regulations, Part 2, Subpart J — Equipment Authorization Procedures:

§ 2.901 Basis and Purpose

- (a) In order to carry out its responsibilities under the Communications Act and the various treaties and international regulations, and in order to promote efficient use of the radio spectrum, the Commission has developed technical standards for radio frequency equipment and parts or components thereof. The technical standards applicable to individual types of equipment are found in that part of the rules governing the service wherein the equipment is to be operated.¹ *In addition to the technical standards provided, the rules governing the service may require that such equipment be verified by the manufacturer or importer, be authorized under a Declaration of Conformity, or receive an equipment authorization from the Commission by one of the following procedures: certification or registration.*
- (b) The following sections describe the verification procedure, the procedure for a Declaration of Conformity, and the procedures to be followed in obtaining certification from the Commission and the conditions attendant to such a grant.

§ 2.907 Certification.

- (a) Certification is an equipment authorization issued by the Commission, based on representation and test data submitted by the applicant.
- (b) Certification attaches to all units subsequently marketed by the grantee which are identical (see Section 2.908) to the sample tested except for permissive changes or other variations authorized by the Commission pursuant to Section 2.1043.

¹ In this case, the equipment is subject to the rules of Part 15. More specifically, the equipment falls under Subpart B (of Part 15), which deals with unintentional radiators.



Certification & User's Manual Information

§ 2.948 Description of measurement facilities.

- (a) Each party making measurements of equipment that is subject to an equipment authorization under Part 15 or Part 18 of this chapter, regardless of whether the measurements are filed with the Commission or kept on file by the party responsible for compliance of equipment marketed within the U.S. or its possessions, shall compile a description of the measurement facilities employed.
- (1) If the measured equipment is subject to the verification procedure, the description of the measurement facilities shall be retained by the party responsible for verification of the equipment.
- (i) *If the equipment is verified through measurements performed by an independent laboratory, it is acceptable for the party responsible for verification of the equipment to rely upon the description of the measurement facilities retained by or placed on file with the Commission by that laboratory. In this situation, the party responsible for the verification of the equipment is not required to retain a duplicate copy of the description of the measurement facilities.*
- (ii) If the equipment is verified based on measurements performed at the installation site of the equipment, no specific site calibration data is required. It is acceptable to retain the description of the measurement facilities at the site at which the measurements were performed.
- (2) If the equipment is to be authorized by the Commission under the certification procedure, the description of the measurement facilities shall be filed with the Commission's Laboratory in Columbia, Maryland. The data describing the measurement facilities need only be filed once but must be updated as changes are made to the measurement facilities or as otherwise described in this section. At least every three years, the organization responsible for filing the data with the Commission shall certify that the data on file is current.



Certification & User's Manual Information

B. Label and User's Manual Information

The following is extracted from Title 47 of the Code of Federal Regulations, Part 15, Subpart A — General:

§ 15.19 Labeling requirements.

(a) *In addition to the requirements in Part 2 of this chapter, a device subject to certification or verification shall be labeled as follows:*

- (1) Receivers associated with the operation of a licensed radio service, e.g., FM broadcast under Part 73 of this chapter, land mobile operation under Part 90, etc., shall bear the following statement in a conspicuous location on the device:

This device complies with Part 15 of the FCC Rules. Operation is subject to the condition that this device does not cause harmful interference.

- (2) A stand-alone cable input selector switch, shall bear the following statement in a conspicuous location on the device:

This device is verified to comply with Part 15 of the FCC Rules for use with cable television service.

- (3) All other devices shall bear the following statement in a conspicuous location on the device:

This device complies with Part 15 of the FCC Rules. Operation is subject to the following two conditions: (1) This device may not cause harmful interference, and (2) this device must accept any interference received, including interference that may cause undesired operation.

- (4) Where a device is constructed in two or more sections connected by wires and marketed together, the statement specified under paragraph (a) of this section is required to be affixed only to the main control unit.

- (5) When the device is so small or for such use that it is not practicable to place the statement specified under paragraph (a) of this section on it, the information required by this paragraph shall be placed in a prominent location in the instruction manual or pamphlet supplied to the user or, alternatively, shall be placed on the container in which the device is marketed. However, the FCC identifier or the unique identifier, as appropriate, must be displayed on the device.

§ 15.21 Information to user.

The users manual or instruction manual for an intentional or unintentional radiator shall caution the user that changes or modifications not expressly approved by the party responsible for compliance could void the user's authority to operate the equipment.



Verification & User's Manual Information

The following is extracted from Title 47 of the Code of Federal Regulations, Part 15, Subpart B — Unintentional Radiators:

§ 15.105 Information to the user.

- (a) For a Class B digital device or peripheral, the instructions furnished the user shall include the following or similar statement, placed in a prominent location in the text of the manual:

Note: This equipment has been tested and found to comply with the limits for a Class B digital device, pursuant to Part 15 of the FCC Rules. These limits are designed to provide reasonable protection against harmful interference when the equipment is operated in a residential environment. This equipment generates, uses, and can radiate radio frequency energy and, if not installed and used in accordance with the instruction manual, may cause harmful interference to radio communications. However, there is no guarantee that interference will not occur in a particular installation. If this equipment does cause harmful interference to radio or television reception, which can be determined by turning the equipment off and on, the user is encouraged to try to correct the interference by one or more of the following measures:

- Reorient or relocate the receiving antenna.
- Increase the separation between the equipment and receiver.
- Connect the equipment into an outlet on a circuit different from that to which the receiver is connected.
- Consult the dealer or an experienced radio/TV technician for help.



End of Report