

# Studio Broadcast System

**bp24 SET UP and USE**

---

**1. REGULATORY AND COMPLIANCE STATEMENTS.....3**

**2. OVERVIEW**

- 2.1 Core Performance Targets
- 2.2 Specifications
- 2.3 System Components
- 2.4 System Block Diagram

**3. BP24 UWB BODY PACK TRANSMITTER .....**

**4. RP32 UWB RECEIVER MODULE .....**

**5. MCU3224 MAIN CONTROL UNIT .....**

- 4.1. FRONT PANEL .....
- 4.2. REAR PANEL.....

**6. GUI INTERFACE .....**

- 5.1. HOME SCREEN .....
- 5.2. TRANSMITTER DETAIL SCREEN .....
- 5.3. MATRIX SCREEN - RECEIVER MEASUREMENT .....
- 5.4. MATRIX SCREEN – TRANSMITTER MEASUREMENT .....
- 5.5. SETUP SCREEN .....

**7. QUICK START .....**

---

# 1. REGULATORY AND COMPLIANCE

2

This device complies with part 15 of the FCC Rules. Operation is subject to the condition that this device does not cause harmful interference.

This device complies with INDUSTRY CANADA R.S.S. 210, en conformité avec IC: RSS-210/CNR210.

Operation is subject to the following conditions: 1) This device may not cause harmful interference and 2) this device must accept any interference received, including interference which may cause undesired operation. Changes or modifications not expressly approved by Audio-Technica could void your authority to operate this equipment.

**Note:** This equipment has been tested and found to comply with the limits for a Class A digital device, pursuant to Part 15 of the FCC Rules. These limits are designed to provide reasonable protection against harmful interference when the equipment is operated in a commercial environment. This equipment generates, uses, and can radiate radio frequency energy and, if not installed and used in accordance with the instruction manual, may cause harmful interference to radio communications. Operation of this equipment in a residential area is unlikely to cause harmful interference. However, if the equipment does cause harmful interference, the user will be required to correct the interference at own expense.

**CAUTION!** Electrical shock can result from removal of SpectraPulse™ components' covers. Refer servicing to qualified service personnel. No user-serviceable parts inside. Do not expose to rain or moisture.

The circuits inside the SpectraPulse™ components have been precisely adjusted for optimum performance and compliance with federal regulations. Do not attempt to open the drm141 Digital Receiver Module (main assembly), ac1707 Audio Control Interface, mtu101 Boundary Microphone Transmitter or cel007 Charger Encryption Interface. To do so will void the warranty, and may cause improper operation.

**Notice to individuals with implanted cardiac pacemakers or AICD devices:**

Any source of RF (radio frequency) energy may interfere with normal functioning of the implanted device. All wireless microphones have low-power transmitters (less than 0.05 watts output) which are unlikely to cause difficulty, especially if they are at least a few inches away. **Note also that any medical-device disruption will cease when the RF transmitting source is turned off. Please contact your physician or medical-device provider if you have any questions, or experience any problems with the use of this or any other RF equipment.**

Please note that your SpectraPulse™ system operates in a frequency band in a way which may make its use subject to certain FCC and other regulatory agency restrictions and licensing requirements. No changes or modifications may be made to this equipment except by the expressly approved responsible party for compliance. Changes or modifications could void the user's authority to operate the equipment, and will also void Audio-Technica warranty coverage. For further information, please contact your local office of the FCC as applicable.

**STATIC HAZARD.** Opening this unit is likely to cause permanent performance malfunction. Evidence of opening will void warranty. Serviceable only by Audio-Technica. Contact Audio-Technica for return authorization should service be necessary.

## 2. Overview

### 2.1 Core Performance Targets

	STUDIO BROADCAST
Operating Method	UWB OOK
Center frequency	6.500GHz
Simultaneous Receive Points	32
Simultaneous Transmitters	24
Audio Dynamic Range	24 bits
Frequency Response	20Hz -20kHz
Latency	<3 mS Analog to Digital out
Audio Interface	MADI/DANTE
External Control Interface	USB/Ethernet
User Interface	Touchscreen GUI
Battery Life	5 hours
Range (single RP line of sight)	90 feet

## 2.2 Specifications

<b>Overall System</b>	
<b>Dynamic Range</b>	>109 dB (A-weighted, typical)
<b>Total Harmonic Distortion</b>	<0.06% (-40dBV input level)

<b>BP24 Specs (inherent to beltpack /</b>	<b>Direct connect</b>
<b>Self Noise @ 0dB gain</b>	-111dBA
<b>Self Noise @ 20dB gain</b>	-106dBA
<b>Sensitivity @ 0dB gain</b>	-44dBV
<b>Sensitivity @ 20dB gain</b>	-23dBV
<b>Dynamic Range</b>	111dB (A-weighted, typical)
<b>SNR @ 0dB gain</b>	67dBA
<b>SNR @ 20 dB gain</b>	82dBA
<b>Maximum Input Level (5% THD)</b>	4.8dBV
<b>Total Harmonic Distortion</b>	<0.06% (-40dBV input level)
<b>Operating Frequency Range</b>	6250MHz – 6750MHz
<b>Tx Output Power</b>	2nW mean
<b>Modulation</b>	none
<b>Emissions Designator</b>	500MN1W

<b>BP24 w/ AT899cL4 or cL4SW mic</b>	
<b>Self-Noise @ 0dB gain</b>	-109dBA
<b>Self-Noise @ 20dB gain</b>	-93dBA
<b>Sensitivity @ 0dB gain</b>	-48dBV
<b>Sensitivity @ 20dB gain</b>	-28dBV
<b>Dynamic Range</b>	109dB (A-weighted, typical)
<b>SNR @ 0dB gain</b>	61dBA
<b>SNR @ 20dB gain</b>	65dBA
<b>Frequency Response</b>	20Hz – 20,000Hz
<b>Impedance</b>	250 ohms
<b>DC current</b>	1.7mA
<b>Battery</b>	2 x AA
<b>Battery life</b>	5 hours

<b>MCU3224</b>	
<b>Frequency Response</b>	20Hz – 20,000Hz
<b>Input/Output Connections</b>	
MADI	2 x 75 ohm BNC to coax, 2 x multimode fiber
DANTE	2 x RJ45
Receivers	32 x 12 V, RJ45
Black burst	1 x BNC
<b>Headphone/Monitor Out</b>	@ 33 ohm load
<b>Total Harmonic Distortion</b>	<0.1%
<b>Noise</b>	-90dBV
<b>Maximum Output Power</b>	200mW
<b>Power</b>	
Redundant AC supply	2 x 110-240V, 50-50Hz, 420W max
Cable	2 x IEC

## 2.3 System Components

Model	Description
BP24	Body Pack Transmitter with Talkback Function
RP32	UWB Receiver and Antenna Module
MCU3224	Main Control Interface Unit (3U)
AT899cL4 or cL4SW	Microphone Microphone with Inline Talkback Switch

## 2.4 System Block Diagram

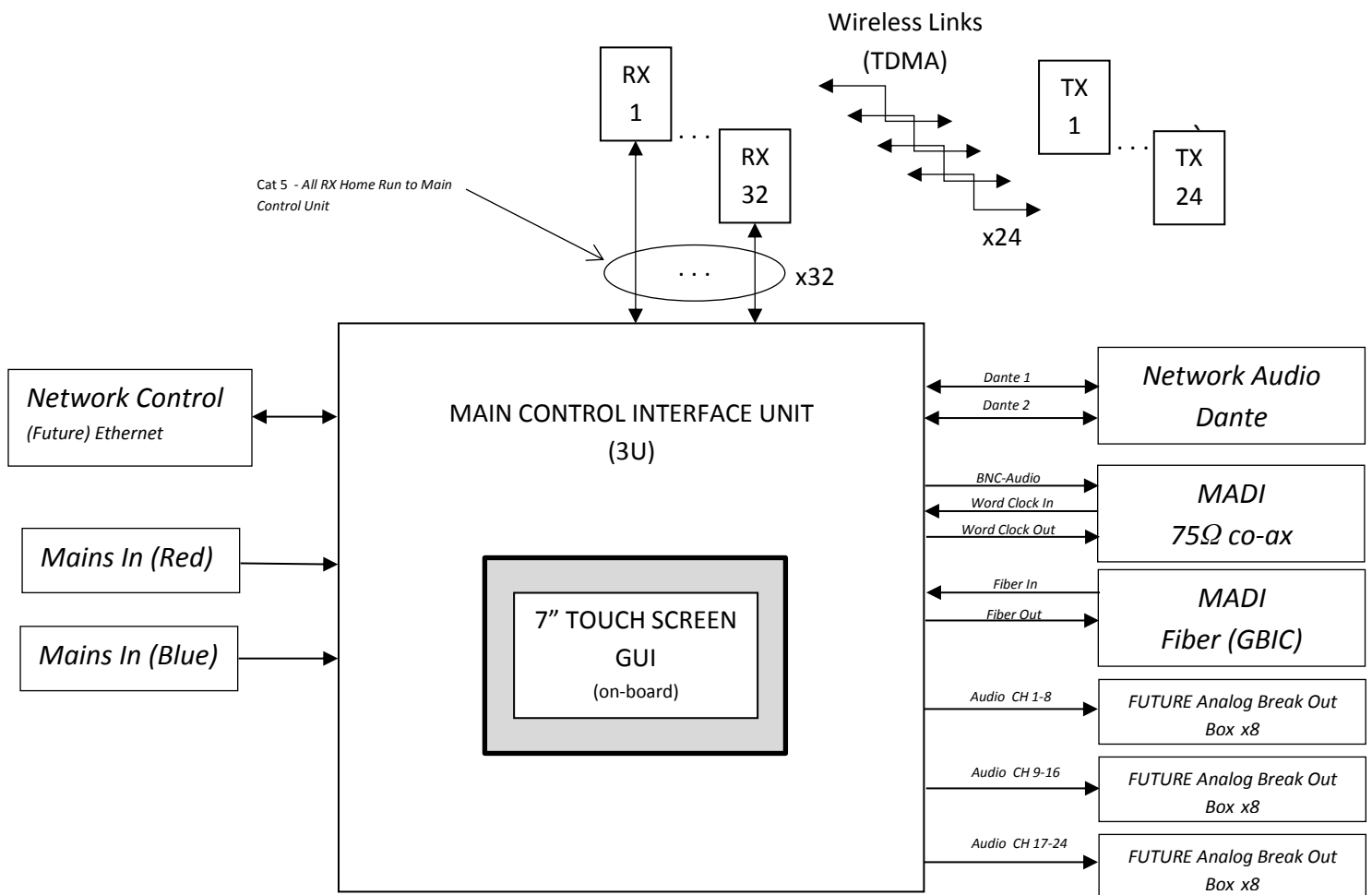

## 3 BP24 UWB Body Pack Transmitter

### 3.1 Transmitter Controls

- An On/Off power switch is located in the battery compartment.
- The adjustable transmitter parameters are:
  1. System ID (SYS) – Each transmitter must be assigned a system ID (1-9) that must match the system ID set on the MCU3224

The transmitter will only transmit when it receives a sync pulse and matching system ID from an active system. This will prevent users with transmitters assigned the same channel slot on a different system from interfering if they enter the coverage area.

Note: RP timing signals from separate systems must be RF isolated from one another to prevent system timing contention in transmitters.

2. Channel Number (CHAN) – The channel slot assigned to the transmitter (01-24.) Each transmitter in the system is assigned a unique channel number.
  3. Input level (GAIN) – Adjustment of the audio input level (0 dB to 20dB in 2dB Steps).
- The adjustable transmitter parameters are shown on a display located on the face of the transmitter.
  - The display will only be illuminated when the user is adjusting the transmitter. Pressing any button will activate the display for 10 seconds. After 10 seconds, display functions will no longer be illuminated although the BP is functioning. Pressing any button will light the display in order to check for power or operating condition.
-



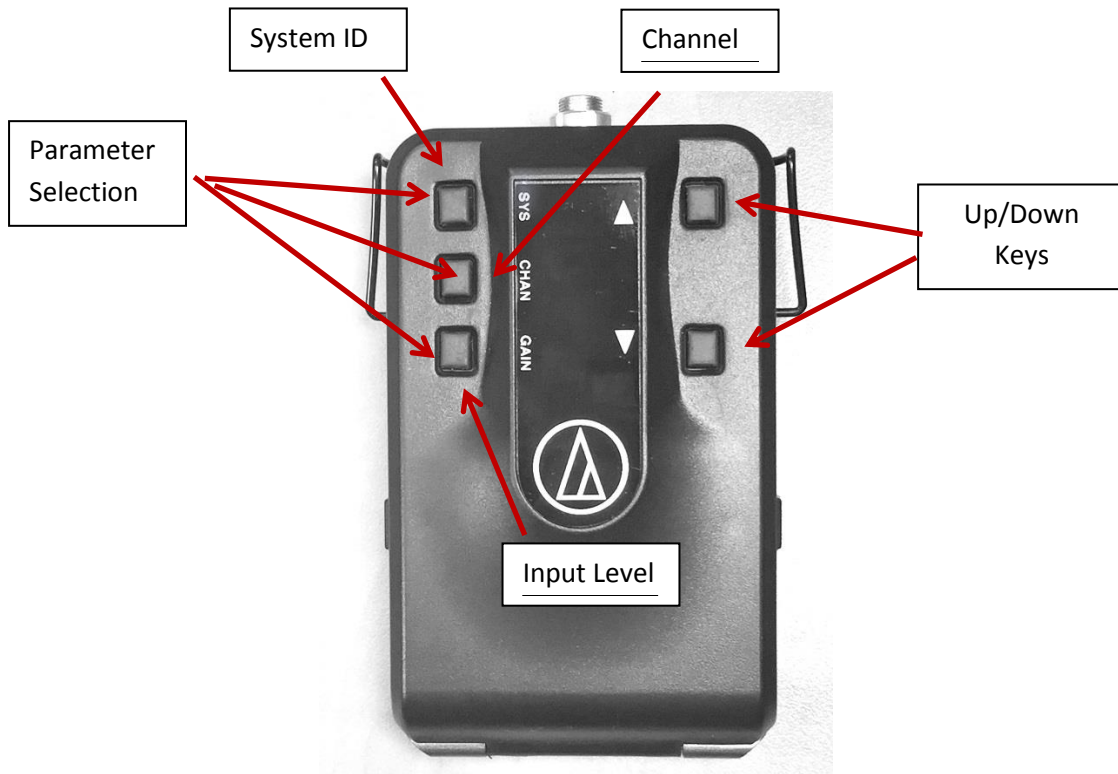

- Adjustment Process:

1. Press and Hold (2 sec) the button associated with the parameter to be adjusted - SYS, CHAN or GAIN.
2. The selected parameter value will flash on the screen.
3. Make the adjustment via the up down arrow keys.
4. The new value will be shown
5. Confirm the change by pressing the same parameter button as step 1.
6. The changed value will flash twice indicating the parameter change.

Note: If there is no button pressed for a 10 second period the transmitter will revert to its original settings and the display will go dark.

Note: No parameter changes will be made unless confirmed as indicated in step 5 above. Pressing a different parameter selection button, or allowing a 10 second period without any input abandons any change in process.

Note: GAIN value is automatically sent to and adjusted at the MCU3224 display. BP GAIN setting may also be changed via MCU3224 transmitter detail screen

## 3.2 Batteries

The BP24 operates via 2 x AA size batteries.

When inserting the batteries into the BP24, observe correct polarity as marked.

Do not peel off or damage the outer tube of the battery.

Do not use a leaking battery. If battery leakage occurs, avoid contact with skin. If contact occurs, immediately wash thoroughly with soap and water. If battery leakage comes into contact with your eyes, immediately flush with water and seek medical attention.

Do not expose batteries to fire. Do not heat, deform, solder, disassemble or modify batteries.

For best operation, do not use batteries of different types together, old or new batteries together, or batteries with different charge levels.

## 3.3 Transmitter Audio Output Routing

The system includes a talkback function utilizing 48 output channels in either the MADI stream or DANTE/AVB network output. In normal operation, audio will be routed to the audio channel that matches the channel slot number assigned (Audio Channel = CHAN = 1 - 24). The talkback function is activated by connecting the appropriate transmitter connector contact (TBD) to ground when the in-line talkback switch is depressed. The talkback function is a press and hold operation. While the talkback button is depressed, the audio output will be routed to a channel in the range of 25 to 48 - equal to the channel slot number + 24 (Audio Channel = CHAN +24). Upon button release, the audio channel returns to the normal operation on the assigned channel 1-24.

## 4 RP32 UWB Receiver Module

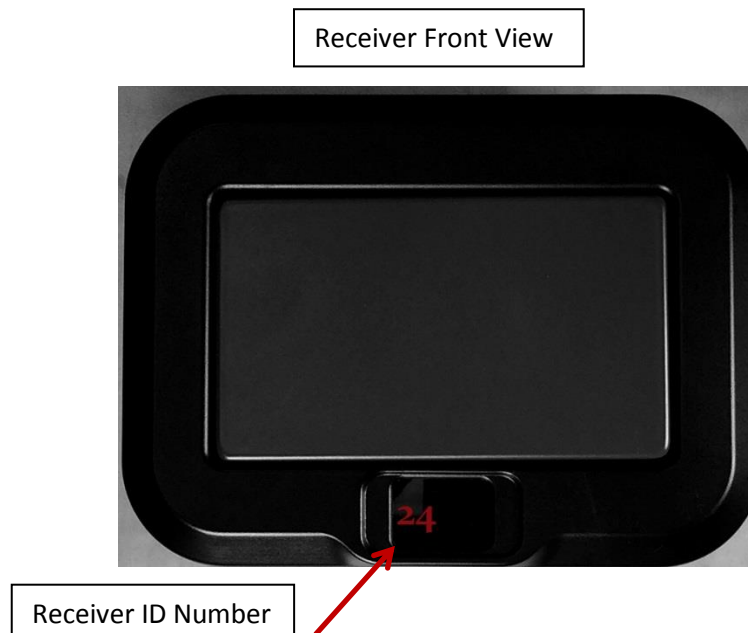

A two digit display (7 Segment LED) is provided to automatically indicate the receiver channel number when the RP32 is connected via a CAT5 cable to the corresponding output channel of the MCU3224. This display serves as the unit's power indicator. A visible channel number also indicates that there is a full round-trip connection between the RP and the MCU communications, confirming that the cable, the RP and the corresponding MCU3224 channel are all operating appropriately. Should the user prefer that the LED lights not be illuminated, there is a control option available on the MCU "tools" screen which allows this RP display lights to be turned off.

Receiver Rear View



RJ45 Connector for Cat5 Cable

Connection to the RP32 is via an RJ45 jack on the rear. Once connected via RJ45 and shielded CAT5 cable to an MCU, the RP is operational. There is no power switch, and no further controls necessary. The MCU3224 supplies operating power and control over RP functions/preferences is available via the tools screen of the MCU3224.

A choice of 2 mounting threads are available on the rear of the RP32. The inserts mate with either 5/8"-27 thread or 1/4"-20 thread adapters.

## 5 MCU3224 Main Control Unit

The main control unit is the central connection and control point for the system. It also supplies the power required to operate up to 32 receivers via standard shielded CAT 5 cable. This unit provides operational coordination, regulates system timing and feeds the output product to the end user's system as desired. The MCU allows user control/adjustment of operating preferences and management of both transmitters and receivers.

The audio outputs - MADI, Networked Audio Protocol are all contained within this 3U sized unit, with appropriate output connections on the rear. A touchscreen GUI, and internal headphone monitor output/meter are provided for user control and monitoring.

The MCU3224 operates via 2 fully redundant 110-220V 50-60Hz AC power supplies via 2 separate standard IEC power cables. The unit is fully operational with a single power cable and power supply. A front panel display will indicate a blue light for the 1<sup>st</sup> power supply and a red light for the 2<sup>nd</sup> power supply.

Front Panel

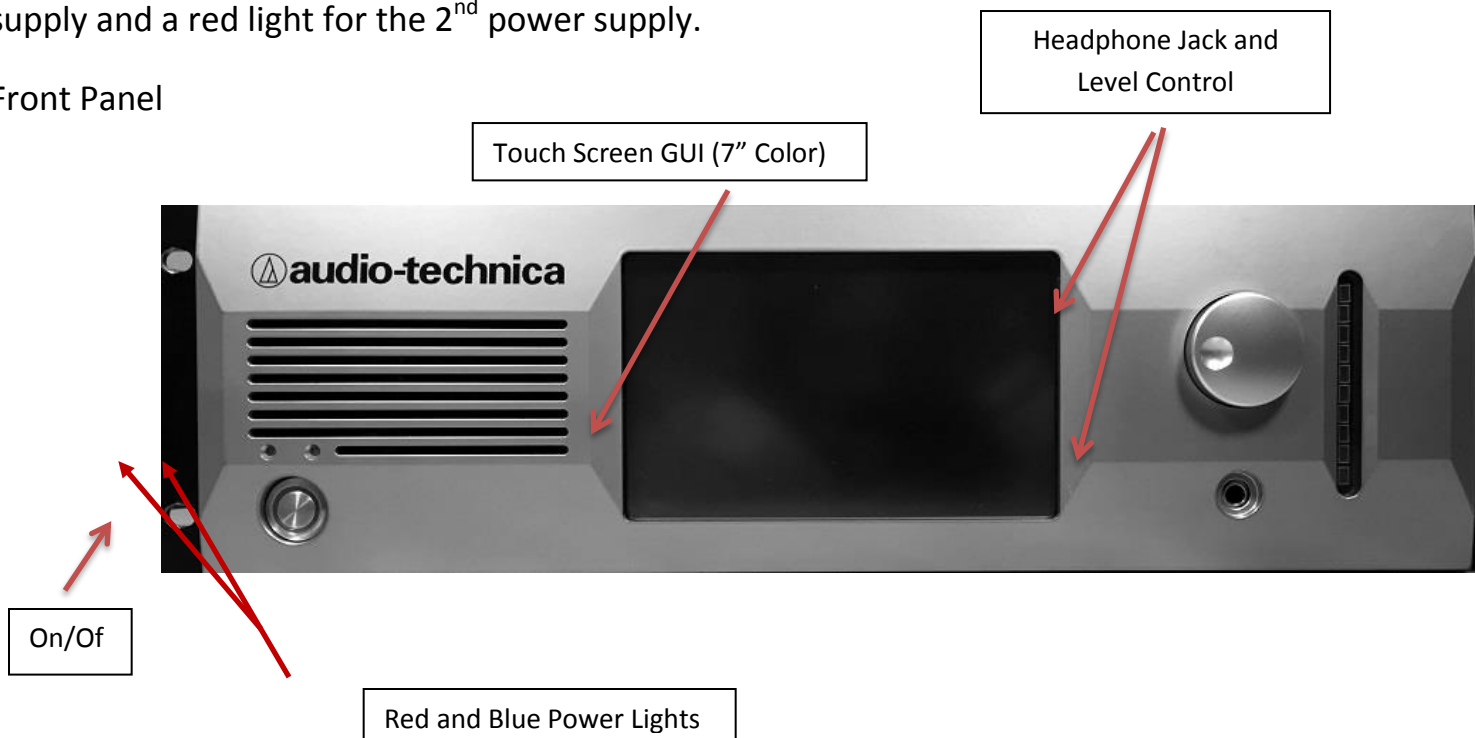



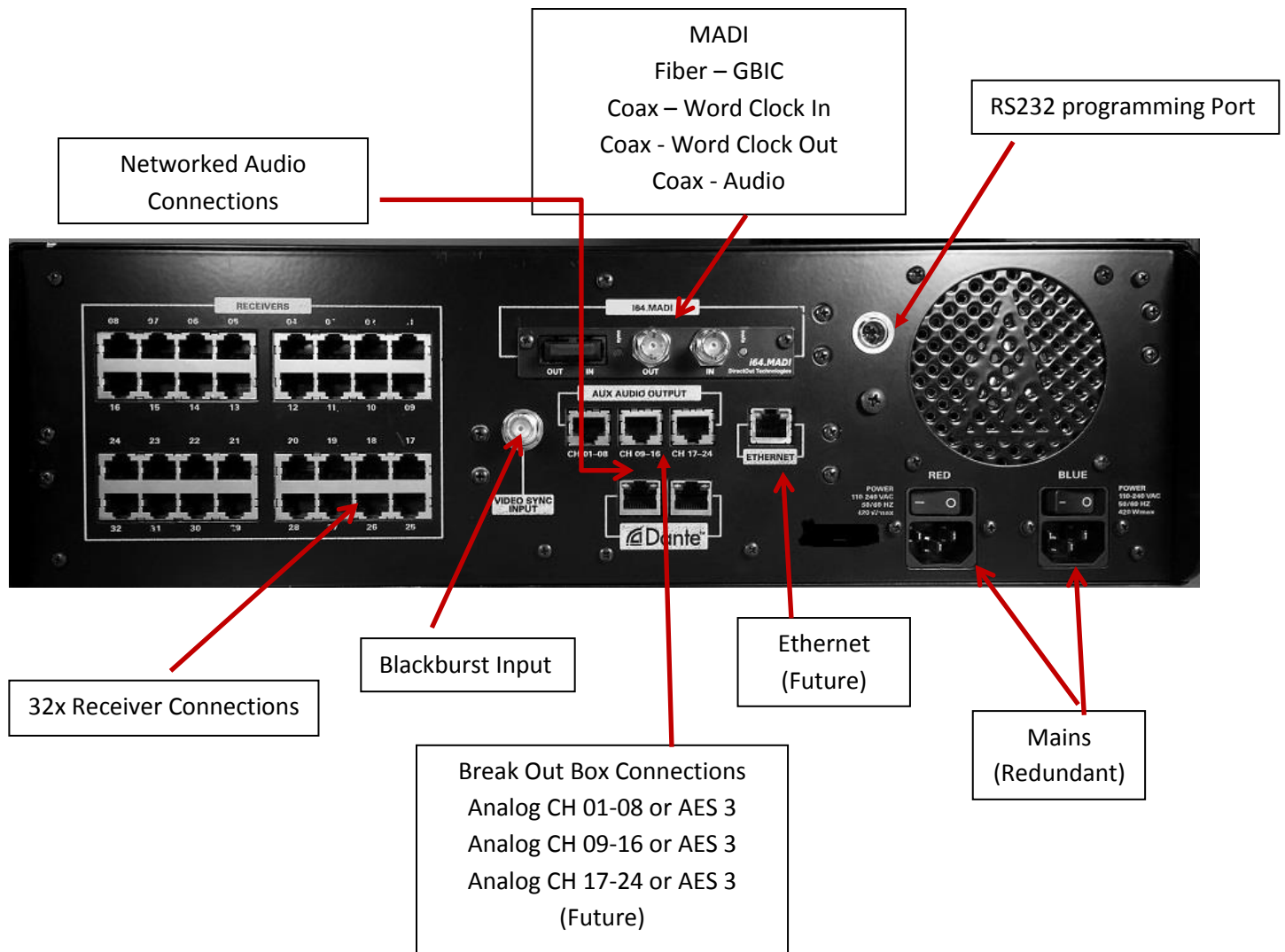

The Front Panel design has minimal controls; the majority of Monitoring and control are handled through the touchscreen GUI. If a channel is selected using the GUI its audio will appear at the headphone jack and VU meter.

## Rear Panel

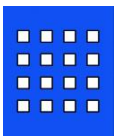

## 6 GUI Interface

The GUI interface is divided into four screens:

	<p><b>Home Screen</b> – This screen will display an overview of all 24 transmit channel slots at once. The user will be able to select the “active” channel on this screen by tapping the corresponding channel tile. The audio from the active channel will be sent to the headphone monitor output.</p>
	<p><b>Transmitter Detail Screen</b> – Activating this screen will display more detailed information about the status of the active channel, including battery information and connection history.</p>
	<p><b>Matrix Screen</b> – This screen is used for system set up, coverage confirmation and detailed debugging of receivers and transmitter links.</p>
	<p><b>System Setup</b> – This screen contains the basic system set up parameters. Dante, and MADI set up information, Ethernet IP Address, System ID etc...  The letter in the center indicates the System ID.</p>



## 6.1 Home Screen

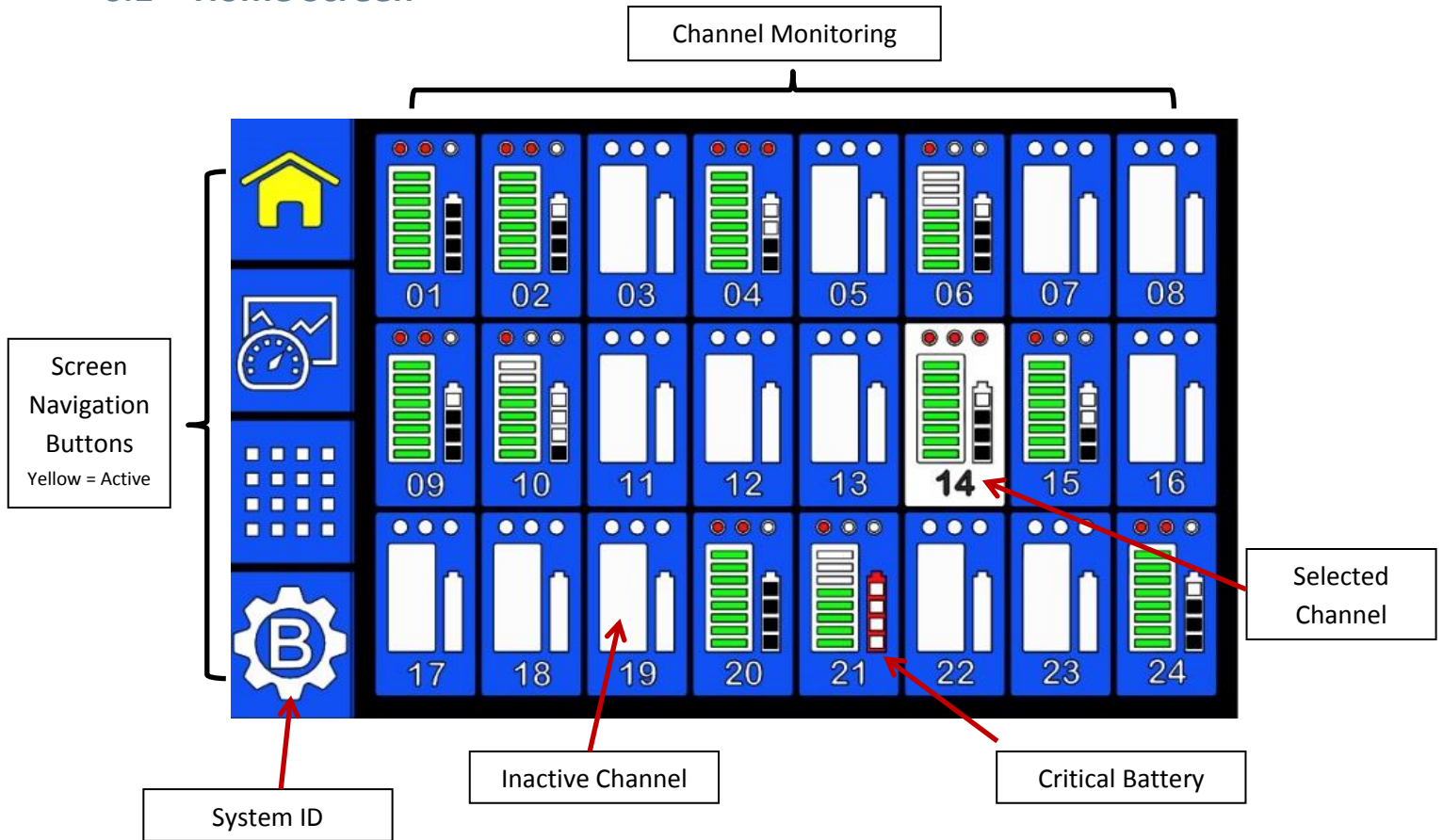

**Receiver Link** Indicators tell the user how many receivers are currently linked to the transmitter (1, 2, or 3+.)

This is a very good indicator of the strength of the transmitter's current UWB link

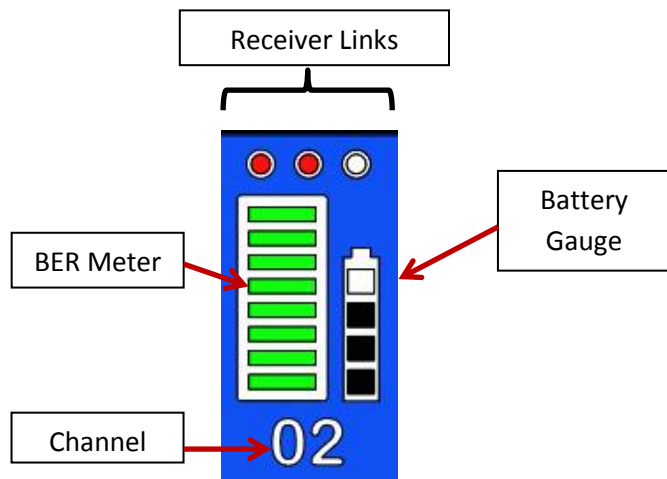



## 6.2 Transmitter Detail Screen

The detail screen gives the user a view of the all transmitter information in one place; including a history of the transmitter’s link status, and battery use details.

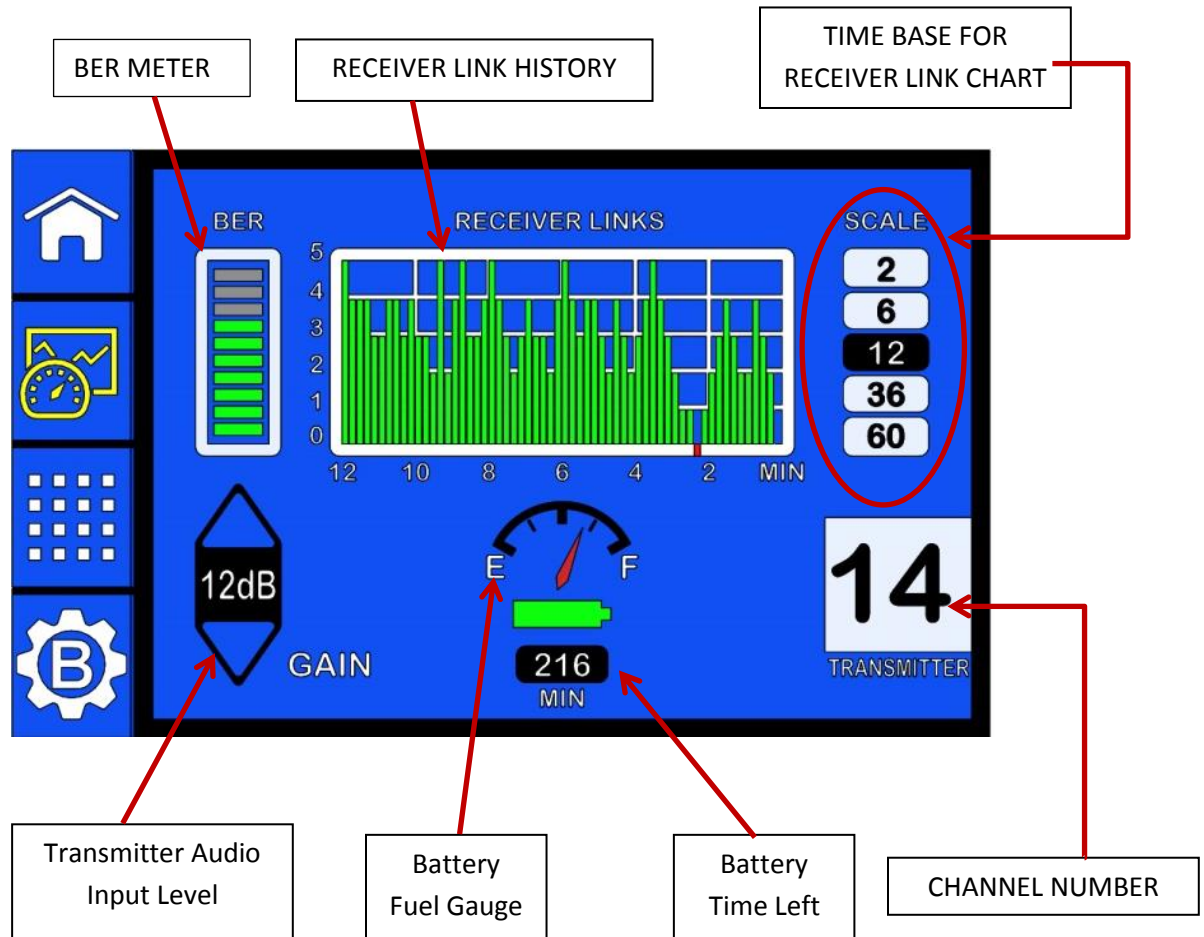

The receiver link chart shows the history of the transmitter link status over the timer scale selected (2 to 60 Min). Each bar indicates the minimum number of receivers the transmitter is linked to. If the link is dropped, a red mark shows the time when it happened.

The user will be able to control the transmitter audio input level from this screen.

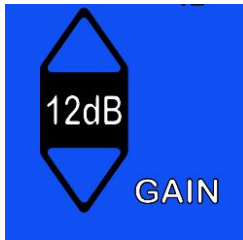

The user may press either the up or down arrow to select the desired gain setting.

This action will cause the new value to be displayed (in red) and a “Set” button will appear. The setting is not changed on the transmitter until the set button is pressed.



Activating another function on the GUI or allowing a 10 second interval without interaction will abandon the change.

Once the set button is pressed, the system will send a command to the transmitter to change the setting. When the transmitter acknowledges the change, the set button will disappear, and the setting color will change back to white.

*Note: When the transmitter is not in link this option will not be available.*

If the transmitter does not acknowledge the change after several attempts, an error message will be displayed and the setting will revert to the previous setting. This would only happen if the transmitter moved out of the coverage pattern during the change process.

### 6.3 Matrix Screen - Receiver Measurement

The matrix screen allows the user to visualize specific connections between 32 possible receivers and 24 possible transmitters. There are two modes: Receiver Test and Transmitter Test.

In the receiver test mode the user selects a source transmitter - blue buttons on the right side of the screen - and the screen on the left indicates the active receivers currently linked to that transmitter. Active receivers are indicated with a blue square; green fill indicates a link to the selected transmitter.

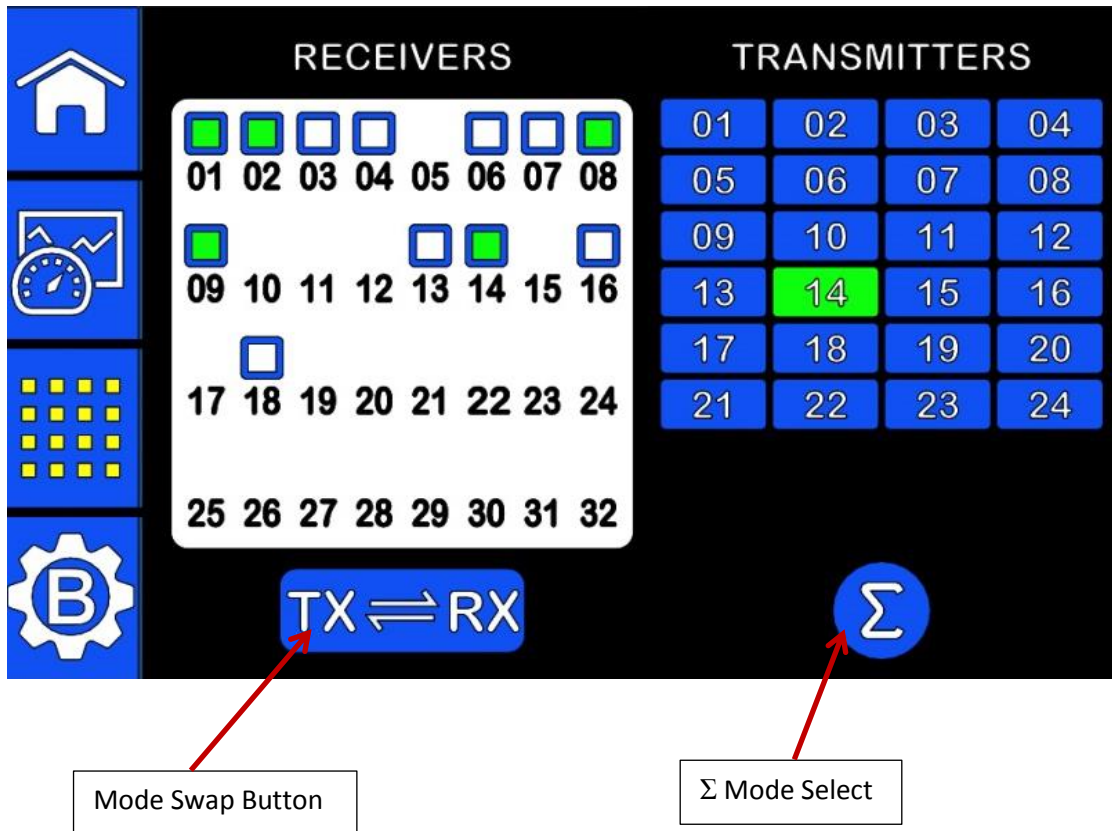

The  $\Sigma$  button is used to view receivers that are connected to ANY active transmitter rather than just a single transmitter. This mode is used to test which receivers are most effective in a given set up, and may assist in receiver placement.

When the user selects the matrix screen, the system will first check for added receivers; without interrupting the operation of the active receivers or the audio output. This gives the user a way to add receivers while the system is in active operation. If the user plugs in a receiver it will not be active until the system goes through this process.

Pressing the mode swap button switches to Transmitter measurement mode.

## 6.4 Matrix Screen – Transmitter Measurement

In the transmitter measurement mode the user selects one of the active receivers – blue buttons on the right side of the screen - and the transmitters linked to that receiver are indicated on the left side of the screen.

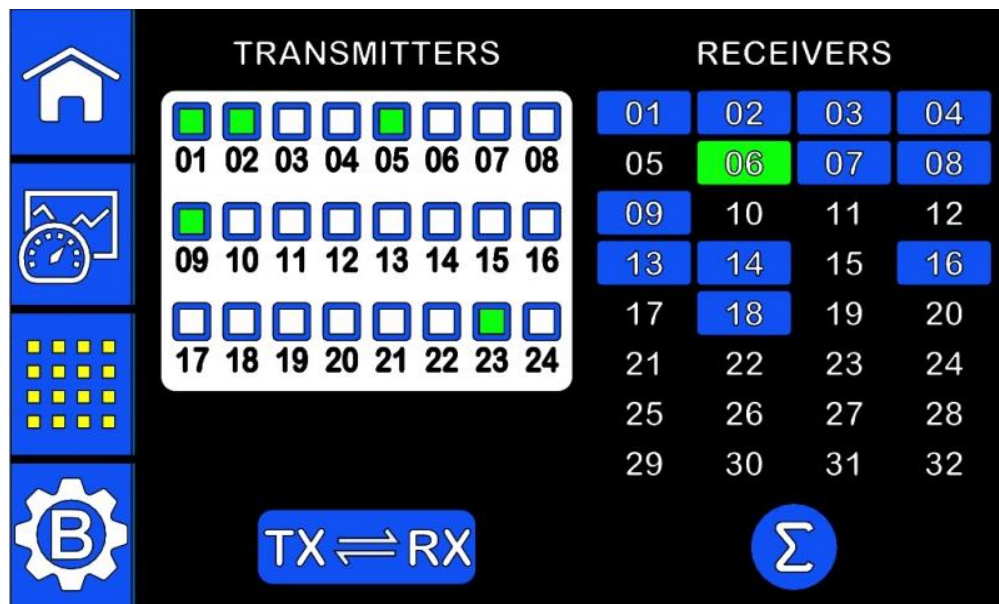

Σ-mode operation is similar - when selected, the system will show transmitters that are connected to any receiver in the system. This is a quick way to make sure that all transmitters are connected to the system by at least one receiver.

## 6.5 Setup Screen – User “TOOLS”

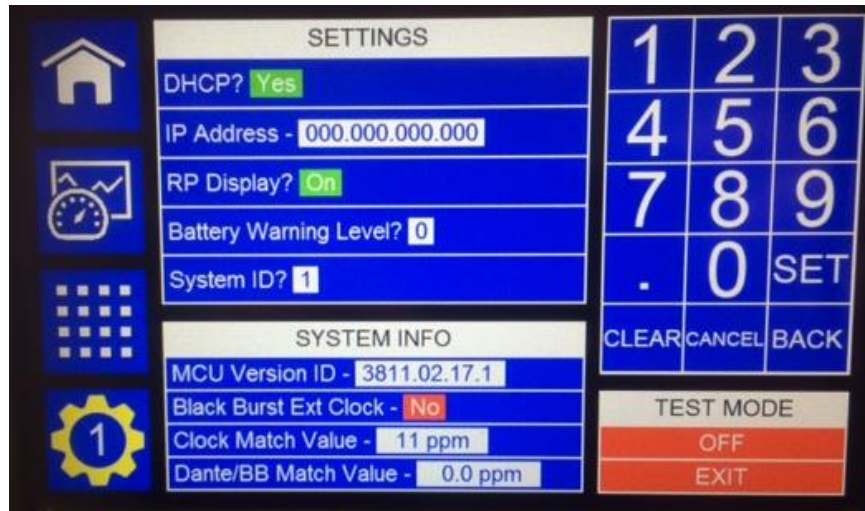

The setup screen allows the user to monitor certain key system performance values or settings, and allows system parameters and operation values which may be determined by user preferences. Monitor and control includes:

- IP Address for the network adaptor
- DHCP
- Dante/AVB Sync precision
- System ID (1-9)
- Reference Clock Source – and BLACK BURST sync match (precision)
- RP display (on/off) control
- Battery fuel gauge time to empty warning “alert” setting preference

- Test Mode – activates a test tone through the system so that the user can carry out a constant-signal walkout test while setting up and de-bugging the system. **NOTE: No normal audio operation is available when in the test tone mode, and the mode must be exited in order for the system to operate normally.**

To enter and activate any of the TOOLS screen functions, press on the screen graphic for the desired parameter. The display for the selected parameter will blink. Press the “SET” button on the number pad to confirm the change.

To enter TEST MODE, press on the screen graphic at the “OFF” position under test mode. The parameter will begin to blink. Enter the Audio-Technica phone number using the key pad by pressing 330 686 2600 and then press “SET.” The display for TEST MODE will now change to a green color and display “ACTIVE.” To immediately stop the TEST TONE, press on the screen where it says “OFF.”

## 7. QUICK START

- Using a shielded CAT 5 cable (may be used with up to 1,000 feet of cable per channel) terminated with a standard RJ45 connector, plug the cable into the RJ45 input jack on the rear of at least one RP32 receiver. Connect the other end of the CAT 5 cable to the RJ45 input jack on the rear of the MCU3224 main control unit. You may connect up to 32 RP32 receivers by connecting them into the corresponding channel output (1-32) found on the rear of the MCU.

You do not need to turn the RP on. It receives power via the CAT 5 cable from the MCU 3224. The RP display should immediately light and display the channel output number to which it has been connected on the MCU.

- Apply power to the MCU3224 by connecting at least one IEC cable to AC wall supply.

- Turn on one or both of the IEC power switches on the rear of the unit. The unit fan will begin operation.
- Press the front panel “power” button.

The power light(s) corresponding to the IEC cable input will be visible on the front panel (one red and one blue), and the GUI screen will illuminate and enter a “set-up” mode while the system is normalizing and preparing for operation.

Once the system is available for operation, the GUI screen will display a “HOME SCREEN.”

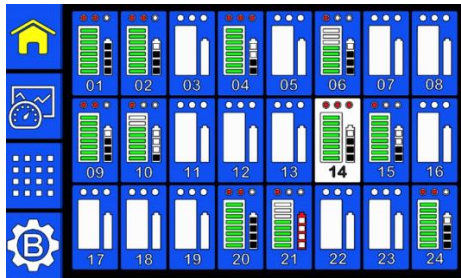

- On the left-hand side of the screen, select the “Matrix” button:



This will allow the user to view and confirm that the desired number of RPs are connected to the system with the desired channel # assignments.

- Place 2 x AA batteries into a BP24 beltpack transmitter and slide the internal power switch into the on position.



Ensure that the BP24 system ID is the same as the System ID of the MCU3224 (system will turn on in “default” system ID 1 for all devices). The System ID is visible in all screens on the left-hand side of the display for “navigation.”

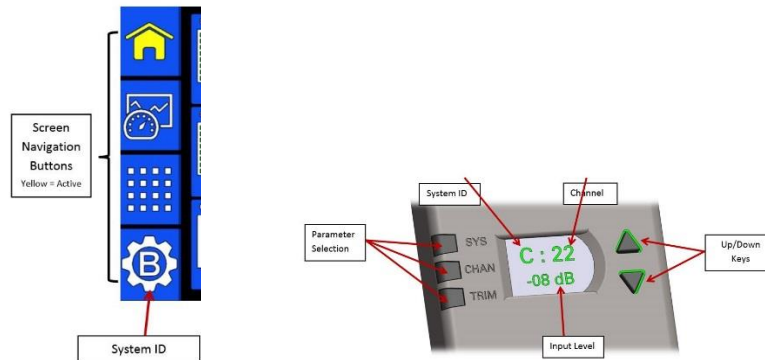

- Select the BP24 channel for operation (1 through 24)
- Select the desired BP24 gain level
- Ensure that the BP24 front surface is facing the RP32 front surface, and that they are located somewhat in proximity to each other and roughly in a line-of sight orientation. (Note that the distance of operation can be 90' or more, depending upon the particular operating environment, and line of sight operation is not strictly or fully required due to positive effects of multi-path. However, with only a single RP connected to the system, the “multiple coordinated receiver diversity” is not in operation. Thus, line of sight and proximity are more important to stable operation for initial set-up with only a single RP).



- Return to the MCU and select the “home screen”



- The BP24 that has just been turned on should be shown in the display on the channel number that you have set via the BP24 channel selection process.
- Press the GUI on the displayed channel to highlight/select the channel of the BP24 that you are operating. This will allow all information about this particular channel to be observed on the other screens. It also selects this particular channel for output to the front-mounted headphone monitor jack.
- You may now listen to your selected beltpack, or if you prefer, you can observe its operation characteristics by selecting the “transmitter detail” button:



- Repeat this process for as many RP32s and BP24s as needed for the application.
- No frequency or channel coordination is required. Simply ensure that only one beltpack channel is in operation for each channel (up to 24) in each system ID. **(Do not attempt to set 2 BP channels to the same channel # in the same system. The system will not operate).**



## One-Year Limited Warranty

Audio-Technica professional wireless systems purchased in the U.S.A. are warranted for one year from date of purchase by Audio-Technica U.S., Inc. (A.T.U.S.) to be free of defects in materials and workmanship. In event of such defect, product will be repaired promptly without charge or, at our option, replaced with a new product of equal or superior value if delivered to A.T.U.S. or an Authorized Service Center, prepaid, together with the sales slip or other proof of purchase date. Prior approval from A.T.U.S. is required for return. This warranty excludes defects due to normal wear, abuse, shipping damage, or failure to use product in accordance with the instructions. This warranty is void in the event of unauthorized repair or modification, or removal or defacing of the product labeling.

For return approval and shipping information, contact the Service Dept., Audio-Technica U.S., Inc., 1221 Commerce Drive, Stow, Ohio 44224.

Except to the extent precluded by applicable state law, A.T.U.S. will have no liability for any consequential, incidental, or special damages; any warranty of merchantability or fitness for particular purpose expires when this warranty expires.

This warranty gives you specific legal rights, and you may have other rights which vary from state to state.

Outside the U.S.A., please contact your local dealer for warranty details.