



Audio-Technica Corporation  
2-46-1, Nishi-Naruse, Machida,  
Tokyo 194-8666, Japan  
Tel. +81-42-739-9168 Fax. +81-42-739-9160  
www.audio-technica.co.jp

Aug 23, 2017

Federal Communications Commission

Equipment Approval Services

7435 Oakland Mills Road

Columbia, MD 21046

## Cover letter

**Audio-Technica Corporation**  
**FCC ID : JFZATH-CKR75BT**  
**IC: 1752B-CKR75BT**  
**Part 15C Certification**

**Class II Permissive Change**

**Original Grant Date : August 17, 2017**

To Gentlemen:

Submitted herewith, on behalf of Audio-Technica Corporation is an application for Part 15C Certification [Class II Permissive Change] of the following In Bluetooth Headphones

We hereby declare that changed model is mechanically and technically identical to original model except attach detail change description document.

Sincerely Yours,

Kamimura Fumio / General Manager

Audio-Technica Corporation

**audio-technica**

## A circuit difference between ATH-CKR75BT and AT-WLA1

ATH-CKR75BT Protection IC Circuit

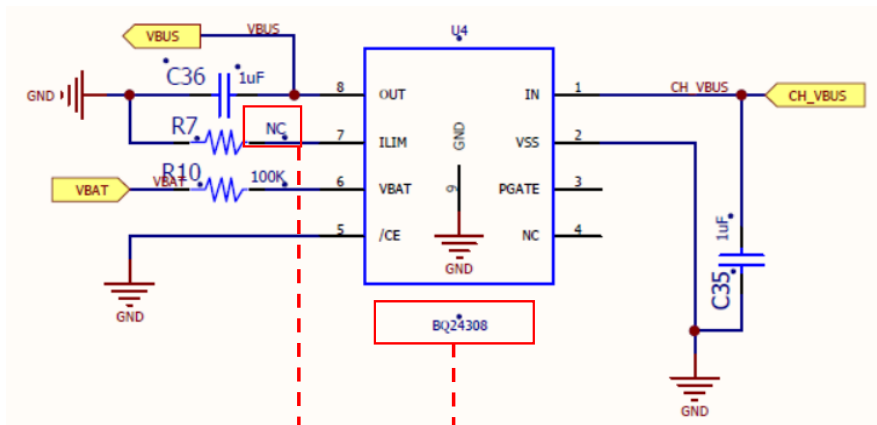

AT-WLA1 Protection IC Circuit

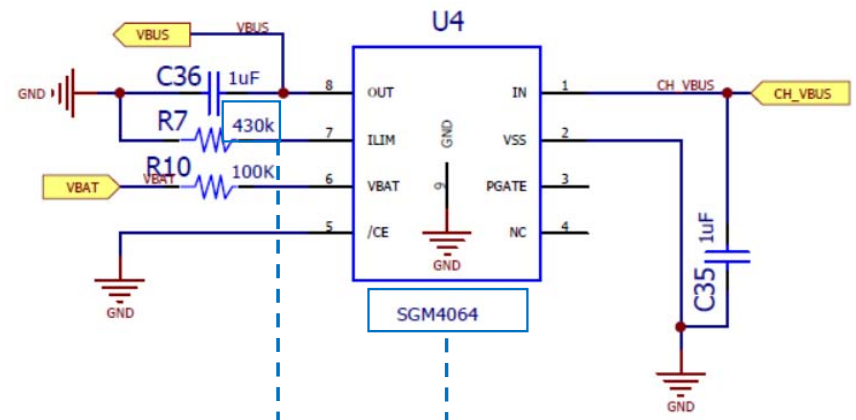

Parts of the U4(Protection IC) and R7(Protection Current Value determination Resistance) are different.

## The Mechanism difference between ATH-CKR75BT and AT-WLA1

ATH-CKR75BT Picture

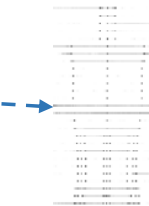
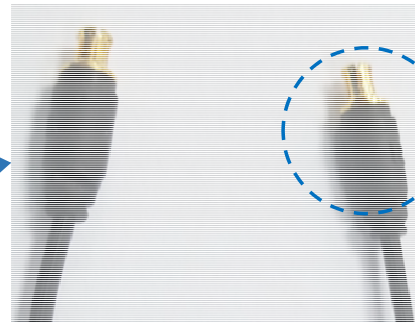

A2DC Jack

ATH-WLA1 Earphone Section Picture(Earphone Not included)



ATH-CKR75BT Earphone Section Picture(Earphone included)