



1.0 Operational Description

The MDR-8705-XX is the MDR-8000/i/s/u version for the unlicensed frequency band: 5725-5850 MHz. It is the latest addition of the Alcatel family of digital microwave products. The MDR-8705-XX radio capacity is OC3 which as a Transport Capacity of 155 Mb/s. The OC3 I/O and the Ethernet I/O baud rates are the same as well as the Transport Capacity of 155 Mb/s and modulation.

The MDR-8000/i/s/u series Microwave Digital Radios (see figure 2-1) consists of:

- Solid-state, licensed, digital radios that provide transport for DS1, E1, and DS3 in 2, 4, 6, 7, 8, 10, and 11 GHz RF frequency bands and OC3 in 4, 6, 7, 8, 10, and 11 GHz RF frequency bands
- Solid-state, unlicensed digital radios that provide transport for DS1, DS3 and OC3 in the 5 GHz RF frequency band.

The following capacities and modulation schemes are available:

- MDR-8000 – 2, 4, 8, 12, or 16 North American Standard DS1 channels at either 32 or 128 TCM, 1 or 3 North American Standard DS3 channels with 1 or 3 wayside DS1 channels at 64 QAM
- MDR-8000i – 2, 4, 8, 12, or 16 CCITT E1 channels at either 32 or 128 TCM
- MDR-8000s – 3 North American Standard STS1 channels with 3 wayside DS1 channels at 128 TCM
- MDR-8000u – 2, 4, 8, or 16 North American Standard DS1 channels at 32 TCM, 1 North American Standard DS3 channel with 1 wayside DS1 channel at 16 or 64 QAM and 1 North American Standard OC3 channel with 3 way sides DS1 channels at 128 TCM.

The radio fits into a standard 19 in. (483 mm) rack and occupies seven vertical rack increments. Up to four fully-equipped hot-standby radios can be mounted in a standard 7 ft rack. The radio is front accessible and can be mounted against a wall or back-to-back against other equipment.

1.1 STANDARD FEATURES

Standard features include:

- Frequency bands from 2 to 11 GHz

- Committee of European Post and Telegraph (CEPT)/Federal Communications Commission (FCC) applications
- DS1, E1, DS3, Ethernet and OC3 Traffic capacities.
- International Telecommunications Union (ITU)/ETSI/FCC compliant
- Five configuration options
- Upstream management compatibility
- User-friendly Personal Computer (PC) monitor and control
- Automatic Transmitter Power Control (ATPC)
- Adaptive Time Domain Equalization (TDE)
- Extended Link Monitor Channel (ELMC)
- MCS-11/Telemetry Byte Oriented Serial (TBOS) Alarm/Control Interface
- Two independent PCM audio channels

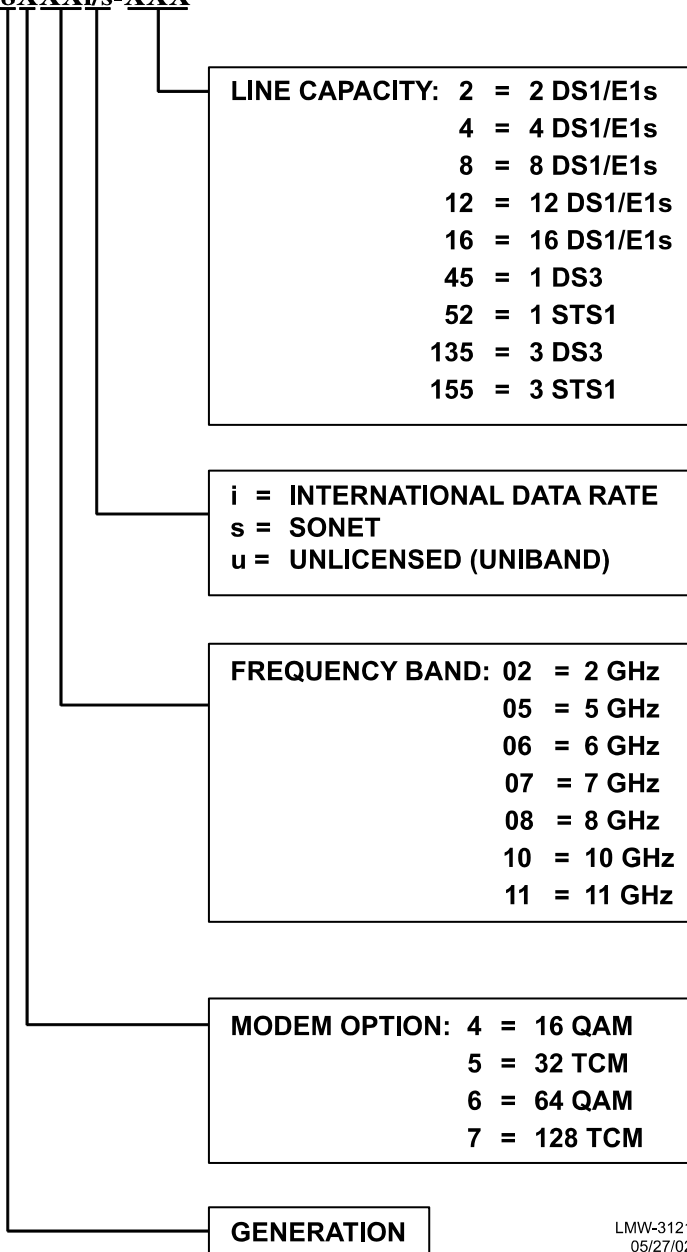

Figure 2-1 Typical MDR-8000/i/s/u Series Microwave Digital Radio

1.2 NAMING CONVENTION

The MDR-8000/i/s/u series radio naming conventions are as follows:

MDR-8XXXi/s-XXX



LMW-3121
05/27/02

1.3 SYSTEM CONFIGURATIONS

The MDR–8000/i/s radio can be provisioned as a terminal, synchronous repeater, ring terminal, or ring repeater.

1.4 RADIO CONFIGURATIONS

1.4.1 Basic Configurations

The MDR–8000/i/s/u supports the three basic configurations:

- Non–standby – available in all frequency bands – stand alone transmitter/receiver combination
- Hot–standby – available in all frequency bands – pair of transmitters and receivers, both pairs operating on the same set of go and return frequencies.
- Frequency diversity – available in all frequency bands except 2 GHz – pair of transmitters and receivers, each pair operating on a different set of go and return frequencies.

1.4.2 Ring

Non–standby radios are typically used in ring systems where the radios are protected by the ring architecture.

1.4.3 Space Diversity Add–On

Space diversity can be added to any of the three basic configurations and ring systems.

1.4.4 Optical 2 X 4 Configuration

Hot–standby and frequency diversity configuration are available with 2–fiber or 4–fiber optical interfaces.

1.5 FEATURES AND OPTIONS

Features and options for the MDR–8000/i/s/u series of microwave digital radios are described in the following paragraphs.

1.5.1 Primary Power

The MDR–8000/i/s/u series radios operate from 20.5 to 60 V dc primary power with positive or negative ground.

1.5.2 Transmit Power Level Options

The standard radio is provided without a power amplifier (PA) module for low-power applications. The optional PA module is available for high-power requirements. There are different levels for the different frequency bands. Refer to the electrical characteristics table in this section for specific levels.

1.5.3 Differential Absolute Delay Equalization (DADE)

DADEing adjusts the differential absolute delay between the main and diversity signals in a space diversity configuration. DADEing is an automatic function within the MDR-8000/i/s/u receivers, reducing the time required for initial turn-up and test.

1.5.4 Trellis Encoding and Time Domain Equalization (TDE)

Trellis encoding (DS1/E1/OC3) ensures that even with the most severe multipath, only the correct digital data is demodulated. TDE further reduces the disruptive effects of multipath distortion.

1.5.5 MCS-11 Alarm/Control Interface

MCS-11 is standard in the MDR-8000. The MDR-8000 can interface with any alarm system that is based on the MCS-11 protocol. Use with the TSM-2500 network management system to develop a central access point to monitor and control the transmission system

1.5.6 Foreign Alarm Interface

This provisioning option provides serial alarm/status reporting for the Telemetry Byte Oriented Serial (TBOS) protocol. A wire-wrap adapter is provided to mate to connector J305 on the backplane.

1.5.7 Relay Interface Option

The optional AE-27AF Relay Interface unit provides relay closure indications of radio alarms and status. The relay interface also provides up to 16 station alarm inputs and six relay closure control outputs.

1.5.8 Extended Link Monitor Channel

ELMC is standard and performance monitoring, alarm and status information, and remote controls are accessible through the ELMC channel, independent of network management interfaces.

Optional remote provisioning and downloading capability is provided via an ELMC option key that is mounted on the controller module.

1.5.9 Automatic Transmitter Power Control Provisioning Option

Automatic Transmitter Power Control (ATPC) is a standard feature that can be enabled or disabled using the USI provisioning screens. When ATPC is disabled, transmitter power is fixed at the recommended maximum level. When ATPC is enabled, transmitter power may be reduced up to 10 dB from the maximum power level when the far end RSL is above a minimum level. When ATPC is enabled with timeout, transmitter ATPC activity is limited to a maximum time without returning to minimum transmit power. After five minutes of activity, the transmit power is forced to minimum until the far end RSL returns to normal levels.

1.5.10 Service Channels Provisioning Options

The MDR–8000 provides a 256 kb/s auxiliary channel for servicing the radio. This is an overhead channel and is independent of the traffic channels. The 256 kb/s service channel contains four 64 kb/s service channels. Three of the four 64 kb/s channels (Service Channel 1, 2, and 3) can be provisioned on the USI for a specific use. Service channel 4 is dedicated to radio commands and ELMC. Service channel 4 is not provisionable. Only 16 kb/s out of the 64 kb/s in this channel are used.

1.5.11 Unlicensed Radio

The MDR–8705u (unlicensed) radio provides fast deployment of service; no license and small antennas (no FCC requirements) allow immediate turnup. After the license is received, the unlicensed radio can be easily converted to the lower 6 GHz licensed band.

The MDR–8705u radio operates in the 5725–5850 Information, Scientific, and Medical (ISM) band in accordance with FCC Part 15.247. This unlicensed radio, although operating in the same band as a spread spectrum radio, operates using narrower bandwidths than spread spectrum. Advantages and disadvantages of the unlicensed radio follow:

Advantages:

- Fast installation and turn up
- OC3 capacities
- Field convertible to lower 6 GHz licensed band
- Common network management with licensed radios.
- Common spares and training with licensed radios

Disadvantages:

- No interference protection
- Operating restrictions

- 5.725 to 5.850 GHz band
- XMT output power 1 Watt
- Performance could deteriorate due to interference as the frequency band becomes congested.

1.5.12 Modulation and Digital Filtering

High Capacity OC3 Radios

The OC3 radio uses the 128 TCM modulation scheme. The 128 TCM provides maximum spectral efficiency for use at congested nodal sites requiring numerous paths or where only limited RF bandwidths are available. A simple capacity key change converts the radio from one type of modulation to the other, offering the user the maximum benefit depending on capacity, path length, and availability requirements. This flexibility also provides radio users the most alternatives in frequency congested areas.

The MDR-8000/i/s employs digital filtering in the transmitter to further reduce out-of-band emissions and digital filtering in the receiver to reject nearby interfering signals. Digital filtering also allows optimum filter partitioning between the transmitter and receiver to produce the greatest system gain attainable for a given modulation technique. Improved filter consistency, repeatability and reliability are additional benefits of digital filters that result in lower user cost by reducing maintenance and replacement part expenses.

Electrical Differences

The major differences between the radios within each RF band are the number and type of input signals that each radio will accept and the bandwidth efficiency. Table 1-1 summarizes the major electrical differences between these radios.

Table 1–1. MDR–8000/i/s/u Radio Types			
<i>RADIO TYPE</i>	<i>CAPACITY (MBPS)</i>	<i>MODULATION</i>	<i>RF BANDWIDTH REQUIREMENT</i>
MDR-85xx-2	2 X 1.544	32 TCM	1.25 MHz (1)
MDR-85xx-4	4 X 1.544	32 TCM	2.50 MHz (1)
MDR-85xx-8	8 X 1.544	32 TCM	3.75 MHz (1)
MDR-85xx-12	12 X 1.544	32 TCM	5.50 MHz (1)
MDR-85xx-16	16 X 1.544	32 TCM	7.50 MHz (1)
MDR-87xx-2	2 X 1.544	128 TCM	0.80 MHz (1)
MDR-87xx-4	4 X 1.544	128 TCM	1.25 MHz (1)
MDR-87xx-8	8 X 1.544	128 TCM	2.50 MHz (1)
MDR-87xx-12	12 X 1.544	128 TCM	3.75 MHz (1)
MDR-87xx-16	16 X 1.544	128 TCM	5.00 MHz (1)
MDR-85xxi-2	2 X 2.048	32 TCM	1.25 MHz (2)
MDR-85xxi-4	4 X 2.048	32 TCM	2.50 MHz (2)
MDR-85xxi-8	8 X 2.048	32 TCM	5.00 MHz (2)
MDR-85xxi-12	12 X 2.048	32 TCM	7.00 MHz (2)
MDR-85xxi-16	16 X 2.048	32 TCM	9.00 MHz (2)
MDR-87xxi-2	2 X 2.048	128 TCM	0.80 MHz (2)
MDR-87xxi-4	4 X 2.048	128 TCM	1.5 MHz (2)
MDR-87xxi-8	8 X 2.048	128 TCM	3.0 MHz (2)
MDR-87xxi-12	12 X 2.048	128 TCM	5.0 MHz (2)
MDR-87xxi-16	16 X 2.048	128 TCM	7.0 MHz (2)
MDR-86xx-45	1 X 44.736	64 QAM	10 MHz
MDR-86xx-135	3 X 44.736	64 QAM	30 MHz
MDR-87xx-52	1 X 51.840	128 TCM	10 MHz
MDR-87xx-155	3 X 51.840	128 TCM	30 MHz
<i>[1]</i> FCC channel bandwidth <i>[2]</i> 99% power bandwidth			

1.6 Functional Description

This section presents a short functional description of the MDR–8000 series radios. The descriptive information covers the radio’s main functions only.

Theory of operation, module description, turn-up procedures, and maintenance are located in the MDR-8000/i/s/u Instruction Book.

1.6.1 MDR–8000 Main Functions

See figure 1–1. In the transmit direction the MDR–8000 uses a modulation structure where the I and Q baseband signals modulate the in–phase and quadrature phase components of the transmitter.

The OC3 I/O interface converts the format of the incoming OC3 data streams to I,Q, data, and clock. The OC3 I/O interface module uses the OC3 signals to generate 128 trellis code amplitude modulated (TCM) baseband signals. The transmitter processes the TCM baseband signals to generate the modulated TCM RF signal. The RF signal is then amplified and applied directly to the antenna branching or further amplified by a solid–state amplifier (optional) and applied to the antenna branching.

In the receive direction, the MDR–8000 uses a demodulation conversion structure. The received TCM signal is fed into a filter followed by a receiver module. The receiver module directly converts the RF signal to I and Q baseband signals and provides all of the acquisition loops. The receiver also provides countermeasures to dynamic path distortions. Clock and digital data are extracted from the analog channels and passed on to the I/O interface. The digital data is processed by the I/O interface module and converted to an OC3 format.

The MDR–8000 consists of I/O, transmit, receive, control and monitor, and power distribution subsystems.

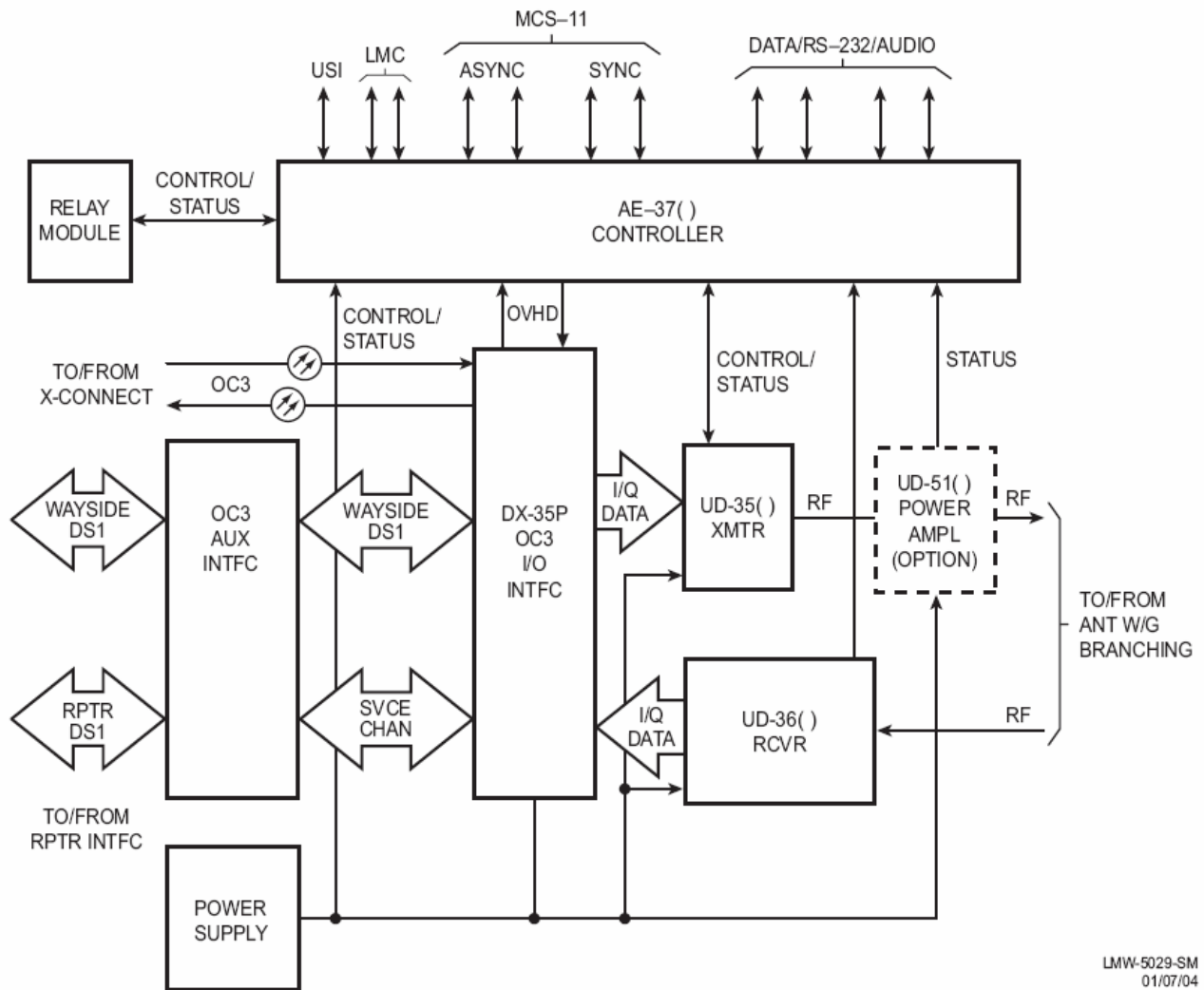

LMW-5029-SM
01/07/04

Figure 3-3 OC3 Non-Standby System Functional Block Diagram

Figure 2.6.1-OC3 Non-Standby System Functional Block Diagram