



APPLICATION FOR FCC CERTIFICATION

ALCATEL USA

Digitally Modulated Radio

| MODEL | FCC ID |
|----------------------|----------------------|
| MDR-8705u-155 | JF6-8705u-155 |

Number of Pages: 32

Date of Report: January 18, 2005

3.3.1 OC3 I/O Subsystem Functional Description

The OC3 STM-1 subsystem consists of the AUX interface board and the I/O interface modules. The I/O subsystem interfaces the XMT and RCV and monitor and control subsystems. The OC3 I/O subsystem converts OC3 STM-1 signals to digital signals and multiplexes this data with overhead data. Multiplexed data is demultiplexed to separate the overhead data from the data stream.

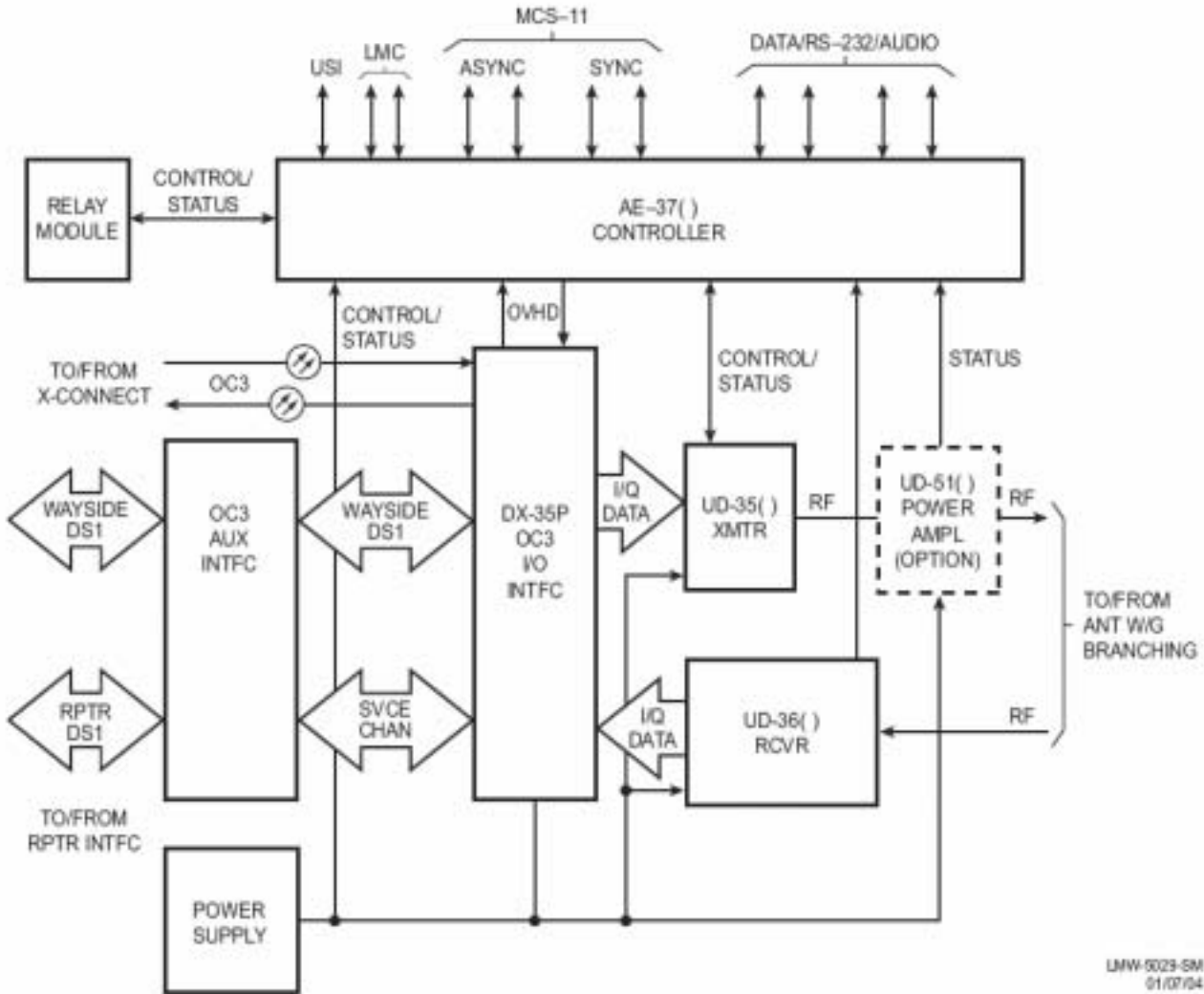

LMW-0029-SM
01/07/04

Figure 3-3 OC3 Non-Standby System Functional Block Diagram