

FCC Test Report (WLAN 5GHz Band)

Report No.: RFBERD-WTW-P21050107-4

FCC ID: JEH-9900-0101

Test Model: 9900-0101-8801

Marketing Name: NCR Orderman9

Received Date: May 05, 2021

Test Date: May 24 ~ Jun. 04, 2021

Issued Date: Jun. 22, 2021

Applicant: NCR Corporation

Address: 864 Spring Street NW Atlanta, GA 30308

Issued By: Bureau Veritas Consumer Products Services (H.K.) Ltd., Taoyuan Branch
Lin Kou Laboratories

Lab Address: No. 47-2, 14th Ling, Chia Pau Vil., Lin Kou Dist., New Taipei City, Taiwan

Test Location: No. 19, Hwa Ya 2nd Rd., Wen Hwa Vil., Kwei Shan Dist., Taoyuan City
33383, Taiwan

**FCC Registration /
Designation Number:** 788550 / TW0003



This report is for your exclusive use. Any copying or replication of this report to or for any other person or entity, or use of our name or trademark, is permitted only with our prior written permission. This report sets forth our findings solely with respect to the test samples identified herein. The results set forth in this report are not indicative or representative of the quality or characteristics of the lot from which a test sample was taken or any similar or identical product specifically and expressly noted. Our report includes all of the tests requested by you and the results thereof based upon the information that you provided to us. You have 60 days from date of issuance of this report to notify us of any material error or omission caused by our negligence, provided, however, that such notice shall be in writing and shall specifically address the issue you wish to raise. A failure to raise such issue within the prescribed time shall constitute your unqualified acceptance of the completeness of this report, the tests conducted and the correctness of the report contents. Unless specific mention, the uncertainty of measurement has been explicitly taken into account to declare the compliance or non-compliance to the specification.

Table of Contents

Release Control Record	4
1 Certificate of Conformity	5
2 Summary of Test Results	6
2.1 Measurement Uncertainty.....	6
2.2 Modification Record.....	6
3 General Information	7
3.1 General Description of EUT.....	7
3.2 Description of Test Modes.....	9
3.2.1 Test Mode Applicability and Tested Channel Detail.....	11
3.3 Duty Cycle of Test Signal.....	13
3.4 Description of Support Units.....	14
3.4.1 Configuration of System under Test.....	14
3.5 General Description of Applied Standards and References.....	15
4 Test Types and Results	16
4.1 Radiated Emission and Bandedge Measurement.....	16
4.1.1 Limits of Radiated Emission and Bandedge Measurement.....	16
4.1.2 Test Instruments.....	17
4.1.3 Test Procedures.....	18
4.1.4 Deviation from Test Standard.....	18
4.1.5 Test Setup.....	19
4.1.6 EUT Operating Conditions.....	20
4.1.7 Test Results.....	21
4.2 Conducted Emission Measurement.....	67
4.2.1 Limits of Conducted Emission Measurement.....	67
4.2.2 Test Instruments.....	67
4.2.3 Test Procedures.....	68
4.2.4 Deviation from Test Standard.....	68
4.2.5 Test Setup.....	68
4.2.6 EUT Operating Conditions.....	68
4.2.7 Test Results.....	69
4.3 Transmit Power Measurement.....	73
4.3.1 Limits of Transmit Power Measurement.....	73
4.3.2 Test Setup.....	73
4.3.3 Test Instruments.....	73
4.3.4 Test Procedure.....	74
4.3.5 Deviation from Test Standard.....	74
4.3.6 EUT Operating Conditions.....	74
4.3.7 Test Result.....	75
4.4 Occupied Bandwidth Measurement.....	86
4.4.1 Test Setup.....	86
4.4.2 Test Instruments.....	86
4.4.3 Test Procedure.....	86
4.4.4 Test Result.....	87
4.5 Peak Power Spectral Density Measurement.....	93
4.5.1 Limits of Peak Power Spectral Density Measurement.....	93
4.5.2 Test Setup.....	93
4.5.3 Test Instruments.....	93
4.5.4 Test Procedures.....	93
4.5.5 Deviation from Test Standard.....	94
4.5.6 EUT Operating Conditions.....	94
4.5.7 Test Results.....	95
4.6 Frequency Stability.....	102
4.6.1 Limits of Frequency Stability Measurement.....	102

4.6.2	Test Setup.....	102
4.6.3	Test Instruments	102
4.6.4	Test Procedure	102
4.6.5	Deviation from Test Standard	103
4.6.6	EUT Operating Condition	103
4.6.7	Test Results	103
4.7	6dB Bandwidth Measurement.....	104
4.7.1	Limits of 6dB Bandwidth Measurement.....	104
4.7.2	Test Setup.....	104
4.7.3	Test Instruments	104
4.7.4	Test Procedure	104
4.7.5	Deviation from Test Standard	104
4.7.6	EUT Operating Condition	104
4.7.7	Test Results	105
5	Pictures of Test Arrangements.....	107
	Annex A- Radiated out of Band Emission (OOBE) Measurement (For U-NII-3 band).....	108
	Annex B- Band Edge Measurement.....	111
	Appendix – Information of the Testing Laboratories	123



Release Control Record

Issue No.	Description	Date Issued
RFBERD-WTW-P21050107-4	Original release	Jun. 22, 2021

1 Certificate of Conformity

Product: NCR Orderman9

Brand: NCR

Test Model: 9900-0101-8801

Marketing Name: NCR Orderman9

Sample Status: Engineering sample

Applicant: NCR Corporation

Test Date: May 24 ~ Jun. 04, 2021

Standards: 47 CFR FCC Part 15, Subpart E (Section 15.407)
ANSI C63.10:2013

The above equipment has been tested by **Bureau Veritas Consumer Products Services (H.K.) Ltd., Taoyuan Branch**, and found compliance with the requirement of the above standards. The test record, data evaluation & Equipment Under Test (EUT) configurations represented herein are true and accurate accounts of the measurements of the sample's RF characteristics under the conditions specified in this report.

Prepared by : Pettie Chen, **Date:** Jun. 22, 2021
Pettie Chen / Senior Specialist

Approved by : Bruce Chen, **Date:** Jun. 22, 2021
Bruce Chen / Senior Project Engineer

2 Summary of Test Results

47 CFR FCC Part 15, Subpart E (Section 15.407)			
FCC Clause	Test Item	Result	Remarks
15.407(b)(6)	AC Power Conducted Emissions	Pass	Meet the requirement of limit. Minimum passing margin is -3.49dB at 0.62689MHz.
15.407(b)(1/2/3/4(i/ii)/6)	Radiated Emissions & Band Edge Measurement	Pass	Meet the requirement of limit. Minimum passing margin is -4.9dB at 56.19MHz.
15.407(a)(1/2/3)	Max Average Transmit Power	Pass	Meet the requirement of limit.
---	Occupied Bandwidth Measurement	-	Reference only.
15.407(a)(1/2/3)	Peak Power Spectral Density	Pass	Meet the requirement of limit.
15.407(e)	6dB bandwidth	Pass	Meet the requirement of limit. (U-NII-3 Band only)
15.407(g)	Frequency Stability	Pass	Meet the requirement of limit.
15.203	Antenna Requirement	Pass	Antenna connector is i-pex(MHF) not a standard connector.

Note:

- Determining compliance based on the results of the compliance measurement, not taking into account measurement instrumentation uncertainty.
- For U-NII-1, U-NII-2a, U-NII-2c band compliance with rule 15.407(b) of the band-edge items, the test plots were recorded in Annex B. Test Procedures refer to report 4.1.3.
For U-NII-3 band compliance with rule part 15.407(b)(4)(i), the OOB test plots were recorded in Annex A.

2.1 Measurement Uncertainty

Where relevant, the following measurement uncertainty levels have been estimated for tests performed on the EUT as specified in CISPR 16-4-2:

Measurement	Frequency	Expanded Uncertainty (k=2) (\pm)
Conducted Emissions at mains ports	150kHz ~ 30MHz	2.79 dB
Radiated Emissions up to 1 GHz	9kHz ~ 30MHz	3.04 dB
	30MHz ~ 200MHz	3.59 dB
	200MHz ~ 1000MHz	3.60 dB
Radiated Emissions above 1 GHz	1GHz ~ 18GHz	2.29 dB
	18GHz ~ 40GHz	2.29 dB

2.2 Modification Record

There were no modifications required for compliance.

3 General Information

3.1 General Description of EUT

Product	NCR Orderman9
Brand	NCR
Test Model	9900-0101-8801
Marketing Name	NCR Orderman9
Sample Status	Engineering sample
Power Supply Rating	3.85Vdv from battery 5Vdc from adapter
Modulation Type	256QAM, 64QAM, 16QAM, QPSK, BPSK
Modulation Technology	OFDM
Transfer Rate	802.11a: 54/48/36/24/18/12/9/6Mbps 802.11n: up to 300Mbps 802.11ac: up to 866.7Mbps
Operating Frequency	5180 ~ 5240MHz, 5260 ~ 5320MHz, 5500 ~ 5720MHz, 5745 ~ 5825MHz
Number of Channel	5180 ~ 5240MHz: 802.11a, 802.11n (HT20), 802.11ac (VHT20): 4 802.11n (HT40), 802.11ac (VHT40): 2 802.11ac (VHT80): 1 5260 ~ 5320MHz: 802.11a, 802.11n (HT20), 802.11ac (VHT20): 4 802.11n (HT40), 802.11ac (VHT40): 2 802.11ac (VHT80): 1 5500 ~ 5720MHz: 802.11a, 802.11n (HT20), 802.11ac (VHT20): 12 802.11n (HT40), 802.11ac (VHT40): 6 802.11ac (VHT80): 3 5745 ~ 5825MHz: 802.11a, 802.11n (HT20), 802.11ac (VHT20): 5 802.11n (HT40), 802.11ac (VHT40): 2 802.11ac (VHT80): 1
Output Power	5180 ~ 5240MHz: 35.091mW 5260 ~ 5320MHz: 51.398mW 5500 ~ 5720MHz: 54.088mW 5745 ~ 5825MHz: 51.656mW
Antenna Type	Refer to Note
Antenna Connector	Refer to Note
Accessory Device	Refer to Note
Cable Supplied	NA

Note:

1. The EUT incorporates a MIMO function. Physically, the EUT provides 2 completed transmitters and 2 receivers.

Modulation Mode	TX Function
802.11a	2TX
802.11n (HT20)	2TX
802.11n (HT40)	2TX
802.11ac (VHT20)	2TX
802.11ac (VHT40)	2TX
802.11ac (VHT80)	2TX

* The modulation and bandwidth are similar for 802.11n mode for 20MHz/40MHz and 802.11ac mode for 20MHz/40MHz, therefore investigated worst case to representative mode in test report. (Final test mode refer section 3.2.1)

2. The EUT consumes power from the following battery and adapter.

Battery (Accessory)	
Brand	NCR
Model	USI-695759PLN-1S1P
Rating	3.85Vdc, 3750mAh, 14.4375Wh

Adapter (Optional)	
Brand	MOSO
Model	MS-V2000U050-010D0-US
Input Power	100-240Vac, 50-60Hz, 0.5A
Output Power	5.0Vdc, 2.0A

3. The following support unit were provided to the EUT.

Product	Brand	Model	Remark
NCR Orderman9 Service Station Cradle-1 slot	NCR	9900-0200-8801	-
NCR Orderman9 Battery Charger	NCR	9900-0302-8801	-
NCR Orderman9 USB adapter cable	NCR	9900-0401-8801	1.43m cable without core

4. The following antennas were provided to the EUT.

Antenna Type	PIFA							
Antenna Connector	i-pex(MHF)							
Freq. (MHz)	2412	2437	2462	5180 - 5240	5260 - 5320	5500 - 5720	5745 - 5825	
Gain (dBi)	Main / BT	0.81	1.43	1.45	5.34	4.00	1.89	1.32
	Aux.	1.52	2.25	2.20	3.63	2.74	4.89	5.60

*The above Antenna information is declared by manufacturer and for more detailed features description, please refer to the manufacturer's specifications, the laboratory shall not be held responsible.

5. There are 4 pre-test modes as below. After pre-testing, mode B, C were the worst for the final tests.

- A. EUT + NB + Cradle
- B. EUT + NB + USB adapter cable
- C. EUT + Adapter + Cradle
- D. EUT + Adapter + USB adapter cable

3.2 Description of Test Modes

For 5180 ~ 5240MHz:

4 channels are provided for 802.11a, 802.11n (HT20), 802.11ac (VHT20):

Channel	Frequency	Channel	Frequency
36	5180 MHz	44	5220 MHz
40	5200 MHz	48	5240 MHz

2 channels are provided for 802.11n (HT40), 802.11ac (VHT40):

Channel	Frequency	Channel	Frequency
38	5190 MHz	46	5230 MHz

1 channel is provided for 802.11ac (VHT80):

Channel	Frequency
42	5210 MHz

For 5260 ~ 5320MHz:

4 channels are provided for 802.11a, 802.11n (HT20), 802.11ac (VHT20):

Channel	Frequency	Channel	Frequency
52	5260 MHz	60	5300 MHz
56	5280 MHz	64	5320 MHz

2 channels are provided for 802.11n (HT40), 802.11ac (VHT40):

Channel	Frequency	Channel	Frequency
54	5270 MHz	62	5310 MHz

1 channel is provided for 802.11ac (VHT80):

Channel	Frequency
58	5290 MHz

For 5500 ~ 5720MHz:

12 channels are provided for 802.11a, 802.11n (HT20), 802.11ac (VHT20):

Channel	Frequency	Channel	Frequency
100	5500 MHz	124	5620 MHz
104	5520 MHz	128	5640 MHz
108	5540 MHz	132	5660 MHz
112	5560 MHz	136	5680 MHz
116	5580 MHz	140	5700 MHz
120	5600 MHz	144	5720 MHz

6 channels are provided for 802.11n (HT40), 802.11ac (VHT40):

Channel	Frequency	Channel	Frequency
102	5510 MHz	126	5630 MHz
110	5550 MHz	134	5670 MHz
118	5590 MHz	142	5710 MHz

3 channels are provided for 802.11ac (VHT80):

Channel	Frequency	Channel	Frequency
106	5530 MHz	122	5610 MHz
138	5690 MHz		

For 5745 ~ 5825MHz:

5 channels are provided for 802.11a, 802.11n (HT20), 802.11ac (VHT20):

Channel	Frequency	Channel	Frequency
149	5745 MHz	161	5805 MHz
153	5765 MHz	165	5825 MHz
157	5785 MHz		

2 channels are provided for 802.11n (HT40), 802.11ac (VHT40):

Channel	Frequency	Channel	Frequency
151	5755 MHz	159	5795 MHz

1 channel is provided for 802.11ac (VHT80):

Channel	Frequency
155	5775 MHz

3.2.1 Test Mode Applicability and Tested Channel Detail

EUT Configure Mode	Applicable to				Description
	RE \geq 1G	RE<1G	PLC	APCM	
A	√	√	√	-	EUT + NB + USB adapter cable
B	-	√	√	√	EUT + Adapter + Cradle

Where RE \geq 1G: Radiated Emission above 1GHz & Bandedge Measurement
 RE<1G: Radiated Emission below 1GHz
 PLC: Power Line Conducted Emission
 APCM: Antenna Port Conducted Measurement

Note:

1. The EUT had been pre-tested on the positioned of each 3 axis. The worst case was found when positioned on **Y-plane**.
2. Radiated emission test (below 1GHz) and power line conducted emission test items chosen the worst maximum power.

Radiated Emission Test (Above 1GHz):

- Pre-Scan has been conducted to determine the worst-case mode from all possible combinations between available modulations, data rates and antenna ports (if EUT with antenna diversity architecture).
- Following channel(s) was (were) selected for the final test as listed below.

EUT Configure Mode	Mode	Frequency Band (MHz)	Available Channel	Tested Channel	Modulation Technology	Data Rate (Mbps)
A	802.11a	5180-5240	36 to 48	36, 40, 48	OFDM	6.0
	802.11ac (VHT20)		36 to 48	36, 40, 48	OFDM	6.5
	802.11ac (VHT40)		38 to 46	38, 46	OFDM	13.5
	802.11ac (VHT80)		42	42	OFDM	29.3
A	802.11a	5260-5320	52 to 64	52, 60, 64	OFDM	6.0
	802.11ac (VHT20)		52 to 64	52, 60, 64	OFDM	6.5
	802.11ac (VHT40)		54 to 62	54, 62	OFDM	13.5
	802.11ac (VHT80)		58	58	OFDM	29.3
A	802.11a	5500-5720	100 to 144	100, 116, 140, 144	OFDM	6.0
	802.11ac (VHT20)		100 to 144	100, 116, 140, 144	OFDM	6.5
	802.11ac (VHT40)		102 to 142	102, 110, 134, 142	OFDM	13.5
	802.11ac (VHT80)		106 to 138	106, 122, 138	OFDM	29.3
A	802.11a	5745-5825	149 to 165	149, 157, 165	OFDM	6.0
	802.11ac (VHT20)		149 to 165	149, 157, 165	OFDM	6.5
	802.11ac (VHT40)		151 to 159	151, 159	OFDM	13.5
	802.11ac (VHT80)		155	155	OFDM	29.3

Radiated Emission Test (Below 1GHz):

- Pre-Scan has been conducted to determine the worst-case mode from all possible combinations between available modulations, data rates and antenna ports (if EUT with antenna diversity architecture).
- Following channel(s) was (were) selected for the final test as listed below.

EUT Configure Mode	Mode	Frequency Band (MHz)	Available Channel	Tested Channel	Modulation Technology	Data Rate (Mbps)
A, B	802.11a	5180-5240	36 to 48	36	OFDM	6.0
	802.11a	5260-5320	52 to 64		OFDM	6.0
	802.11a	5500-5720	100 to 144		OFDM	6.0
	802.11a	5745-5825	149 to 165		OFDM	6.0

Power Line Conducted Emission Test:

- Pre-Scan has been conducted to determine the worst-case mode from all possible combinations between available modulations, data rates and antenna ports (if EUT with antenna diversity architecture).
- Following channel(s) was (were) selected for the final test as listed below.

EUT Configure Mode	Mode	Frequency Band (MHz)	Available Channel	Tested Channel	Modulation Technology	Data Rate (Mbps)
A, B	802.11a	5180-5240	36 to 48	36	OFDM	6.0
	802.11a	5260-5320	52 to 64		OFDM	6.0
	802.11a	5500-5720	100 to 144		OFDM	6.0
	802.11a	5745-5825	149 to 165		OFDM	6.0

Antenna Port Conducted Measurement:

- This item includes all test value of each mode, but only includes spectrum plot of worst value of each mode.
- Pre-Scan has been conducted to determine the worst-case mode from all possible combinations between available modulations, data rates and antenna ports (if EUT with antenna diversity architecture).
- Following channel(s) was (were) selected for the final test as listed below.

EUT Configure Mode	Mode	Frequency Band (MHz)	Available Channel	Tested Channel	Modulation Technology	Data Rate (Mbps)
B	802.11a	5180-5240	36 to 48	36, 40, 48	OFDM	6.0
	802.11ac (VHT20)		36 to 48	36, 40, 48	OFDM	6.5
	802.11ac (VHT40)		38 to 46	38, 46	OFDM	13.5
	802.11ac (VHT80)		42	42	OFDM	29.3
B	802.11a	5260-5320	52 to 64	52, 60, 64	OFDM	6.0
	802.11ac (VHT20)		52 to 64	52, 60, 64	OFDM	6.5
	802.11ac (VHT40)		54 to 62	54, 62	OFDM	13.5
	802.11ac (VHT80)		58	58	OFDM	29.3
B	802.11a	5500-5720	100 to 144	100, 116, 140, 144	OFDM	6.0
	802.11ac (VHT20)		100 to 144	100, 116, 140, 144	OFDM	6.5
	802.11ac (VHT40)		102 to 142	102, 110, 134, 142	OFDM	13.5
	802.11ac (VHT80)		106 to 138	106, 122, 138	OFDM	29.3
B	802.11a	5745-5825	149 to 165	149, 157, 165	OFDM	6.0
	802.11ac (VHT20)		149 to 165	149, 157, 165	OFDM	6.5
	802.11ac (VHT40)		151 to 159	151, 159	OFDM	13.5
	802.11ac (VHT80)		155	155	OFDM	29.3

Test Condition:

Applicable to	Environmental Conditions	Input Power	Tested by
RE \geq 1G	22 deg. C, 66% RH	120Vac, 60Hz	Rex Wang
RE<1G	22 deg. C, 66% RH	120Vac, 60Hz	Rex Wang
PLC	25 deg. C, 75% RH	120Vac, 60Hz	Rex Wang
APCM	25 deg. C, 60% RH	120Vac, 60Hz	Ivan Tseng

3.3 Duty Cycle of Test Signal

Duty cycle of test signal is < 98%, duty factor is required.

802.11a: Duty cycle = $2.02/2.285 = 0.884$, Duty factor = $10 * \log(1/0.884) = 0.54$

802.11ac (VHT20): Duty cycle = $1.875/2.005 = 0.935$, Duty factor = $10 * \log(1/0.935) = 0.29$

802.11ac (VHT40): Duty cycle = $0.875/1.075 = 0.814$, Duty factor = $10 * \log(1/0.814) = 0.89$

802.11ac (VHT80): Duty cycle = $0.454/0.559 = 0.812$, Duty factor = $10 * \log(1/0.812) = 0.90$

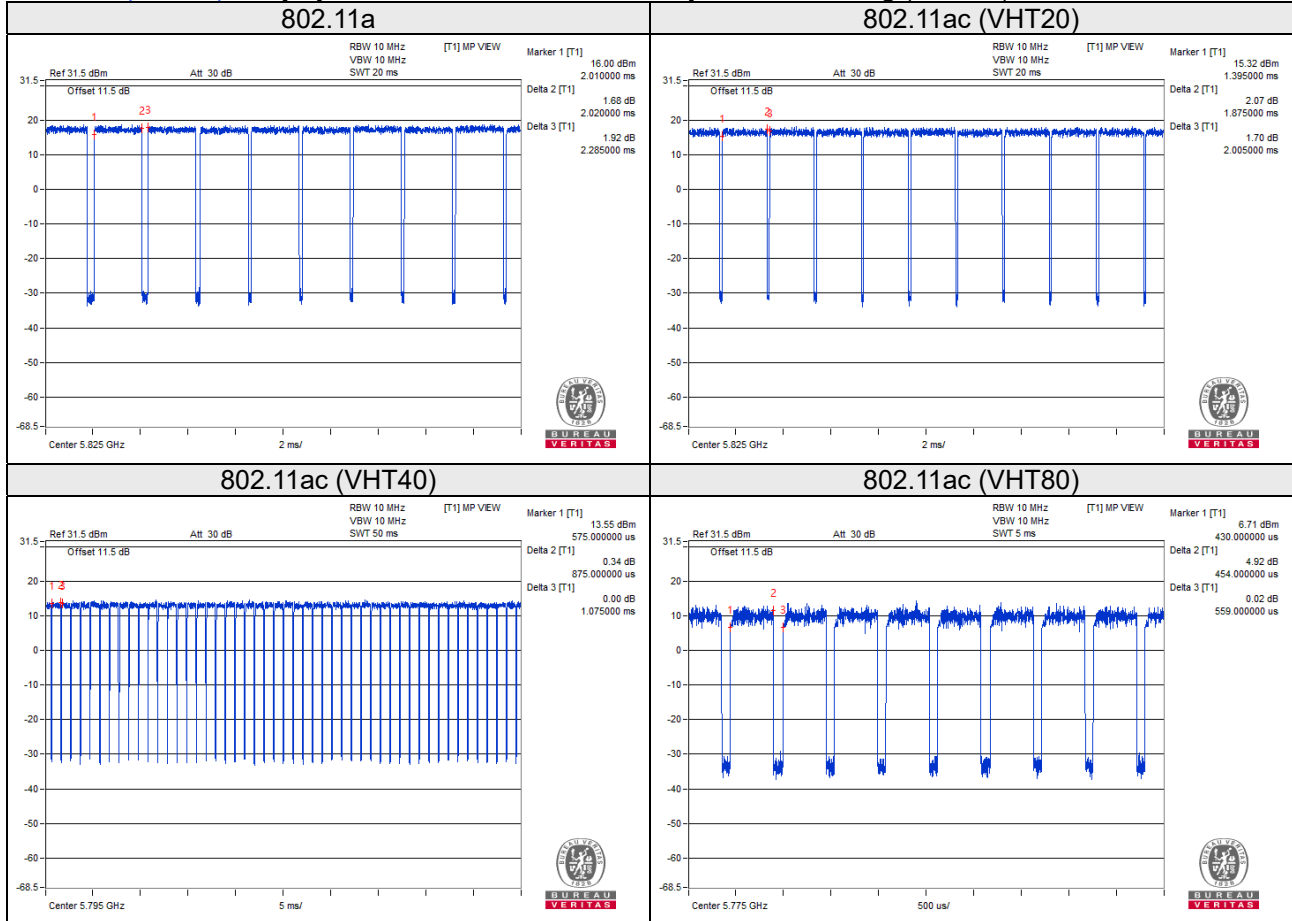

3.4 Description of Support Units

The EUT has been tested as an independent unit together with other necessary accessories or support units. The following support units or accessories were used to form a representative test configuration during the tests.

ID	Product	Brand	Model No.	Serial No.	FCC ID	Remarks
A.	NCR Orderman9 USB adapter cable	NCR	9900-0401-8801	NA	NA	Provided by client
B.	NCR Orderman9 Service Station Cradle-1 slot	NCR	9900-0200-8801	NA	NA	Provided by client
C.	Notebook	Lenovo	20J4 MD A003TW	PF-11H9AK	FCC DoC Approved	-
D.	Adapter	MOSO	MS-V2000U050-010 D0-US	NA	NA	Provided by client

ID	Descriptions	Qty.	Length (m)	Shielding (Yes/No)	Cores (Qty.)	Remarks
1.	USB Cable	1	1.43	Y	0	Attached on NCR Orderman9 USB adapter cable
2.	USB To Type C Cable	1	1.45	Y	0	Provided by client

3.4.1 Configuration of System under Test

Test Mode A

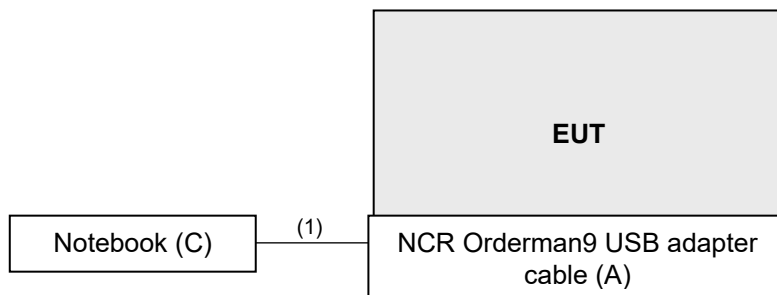

Test Mode B

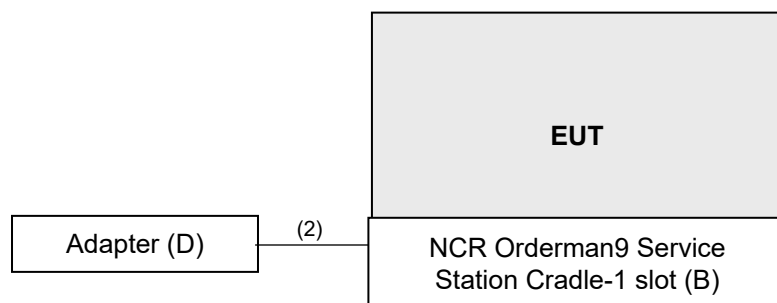

3.5 General Description of Applied Standards and References

The EUT is a RF Product. According to the specifications of the manufacturer, it must comply with the requirements of the following standards and references:

Test standard:

FCC Part 15, Subpart E (15.407)

ANSI C63.10:2013

All test items have been performed and recorded as per the above standards.

KDB References Test Guidance:

KDB 789033 D02 General UNII Test Procedure New Rules v02r01

KDB 662911 D01 Multiple Transmitter Output v02r01

All test items have been performed as a reference to the above KDB test guidance.

4 Test Types and Results

4.1 Radiated Emission and Bandedge Measurement

4.1.1 Limits of Radiated Emission and Bandedge Measurement

Radiated emissions which fall in the restricted bands must comply with the radiated emission limits specified as below table.

Frequencies (MHz)	Field Strength (microvolts/meter)	Measurement Distance (meters)
0.009 ~ 0.490	2400/F(kHz)	300
0.490 ~ 1.705	24000/F(kHz)	30
1.705 ~ 30.0	30	30
30 ~ 88	100	3
88 ~ 216	150	3
216 ~ 960	200	3
Above 960	500	3

Note:

1. The lower limit shall apply at the transition frequencies.
2. Emission level (dBuV/m) = 20 log Emission level (uV/m).
3. For frequencies above 1000MHz, the field strength limits are based on average detector, however, the peak field strength of any emission shall not exceed the maximum permitted average limits, specified above by more than 20dB under any condition of modulation.

Limits of unwanted emission out of the restricted bands

Applicable To		Limit	
789033 D02 General UNII Test Procedure New Rules v02r01		Field Strength at 3m	
		PK: 74 (dBµV/m)	AV: 54 (dBµV/m)
Frequency Band	Applicable To	EIRP Limit	Equivalent Field Strength at 3m
5150~5250 MHz	15.407(b)(1)	PK: -27 (dBm/MHz)	PK: 68.2(dBµV/m)
5250~5350 MHz	15.407(b)(2)		
5470~5725 MHz	15.407(b)(3)		
5725~5850 MHz	<input checked="" type="checkbox"/> 15.407(b)(4)(i)	PK: -27 (dBm/MHz) ^{*1} PK: 10 (dBm/MHz) ^{*2} PK: 15.6 (dBm/MHz) ^{*3} PK: 27 (dBm/MHz) ^{*4}	PK: 68.2(dBµV/m) ^{*1} PK: 105.2 (dBµV/m) ^{*2} PK: 110.8(dBµV/m) ^{*3} PK: 122.2 (dBµV/m) ^{*4}
	<input type="checkbox"/> 15.407(b)(4)(ii)	Emission limits in section 15.247(d)	
^{*1} beyond 75 MHz or more above of the band edge.		^{*2} below the band edge increasing linearly to 10 dBm/MHz at 25 MHz above.	
^{*3} below the band edge increasing linearly to a level of 15.6 dBm/MHz at 5 MHz above.		^{*4} from 5 MHz above or below the band edge increasing linearly to a level of 27 dBm/MHz at the band edge.	

Note: The following formula is used to convert the equipment isotropic radiated power (eirp) to field strength:

$$E = \frac{1000000\sqrt{30P}}{3} \text{ } \mu\text{V/m, where P is the eirp (Watts).}$$

4.1.2 Test Instruments

Description & Manufacturer	Model No.	Serial No.	Cal. Date	Cal. Due
Test Receiver KEYSIGHT	N9038A	MY55420137	Apr. 09, 2021	Apr. 08, 2022
Spectrum Analyzer ROHDE & SCHWARZ	FSP40	100039	Jun. 12, 2020	Jun. 11, 2021
BILOG Antenna SCHWARZBECK	VULB9168	9168-160	Nov. 06, 2020	Nov. 05, 2021
HORN Antenna SCHWARZBECK	BBHA 9120 D	9120D-1169	Nov. 22, 2020	Nov. 21, 2021
HORN Antenna SCHWARZBECK	BBHA 9170	BBHA9170241	Nov. 22, 2020	Nov. 21, 2021
Loop Antenna TESEQ	HLA 6121	45745	Jul. 06, 2020	Jul. 05, 2021
Preamplifier Agilent (Below 1GHz)	8447D	2944A10638	Jun. 08, 2020	Jun. 07, 2021
Preamplifier Agilent (Above 1GHz)	8449B	3008A02367	Feb. 17, 2021	Feb. 16, 2022
RF signal cable HUBER+SUHNER&EMCI	SUCOFLEX 104 & EMC104-SM-SM8000	CABLE-CH9-02 (248780+171006)	Jan. 16, 2021	Jan. 15, 2022
RF signal cable HUBER+SUHNER	SUCOFLEX 104	CABLE-CH9-(250795 /4)	Jan. 16, 2021	Jan. 15, 2022
RF signal cable Woken	8D-FB	Cable-CH9-01	Jun. 08, 2020	Jun. 07, 2021
Software BV ADT	ADT_Radiated_ V7.6.15.9.5	NA	NA	NA
Antenna Tower & Turn BV ADT	AT100	AT93021705	NA	NA
Turn Table BV ADT	TT100	TT93021705	NA	NA
Turn Table Controller BV ADT	SC100	SC93021705	NA	NA
Boresight Antenna Fixture	FBA-01	FBA-SIP01	NA	NA
Pre-amplifier (18GHz-40GHz) EMC	EMC184045B	980175	Sep. 04, 2020	Sep. 03, 2021
USB Wideband Power Sensor KEYSIGHT	U2021XA	MY55050005/MY551 90004/MY55190007/ MY55210005	Jul. 13, 2020	Jul. 12, 2021

- Note: 1. The calibration interval of the above test instruments is 12 months and the calibrations are traceable to NML/ROC and NIST/USA.
2. The test was performed in HwaYa Chamber 9.

4.1.3 Test Procedures

For Radiated emission below 30MHz

- a. The EUT was placed on the top of a rotating table 0.8 meters above the ground at a 3 meter chamber room. The table was rotated 360 degrees to determine the position of the highest radiation.
- b. The EUT was set 3 meters away from the interference-receiving antenna, which was mounted on the top of a variable-height antenna tower.
- c. Parallel, perpendicular, and ground-parallel orientations of the antenna are set to make the measurement.
- d. For each suspected emission, the EUT was arranged to its worst case and the rotatable table was turned from 0 degrees to 360 degrees to find the maximum reading.
- e. The test-receiver system was set to Quasi-Peak Detect Function and Specified Bandwidth with Maximum Hold Mode.

Note:

1. The resolution bandwidth and video bandwidth of test receiver/spectrum analyzer is 9kHz at frequency below 30MHz.

For Radiated emission above 30MHz

- a. The EUT was placed on the top of a rotating table 0.8 meters (for 30MHz ~ 1GHz) / 1.5 meters (for above 1GHz) above the ground at 3 meter chamber room for test. The table was rotated 360 degrees to determine the position of the highest radiation.
- b. The EUT was set 3 meters away from the interference-receiving antenna, which was mounted on the top of a variable-height antenna tower.
- c. The height of antenna is varied from one meter to four meters above the ground to determine the maximum value of the field strength. Both horizontal and vertical polarizations of the antenna are set to make the measurement.
- d. For each suspected emission, the EUT was arranged to its worst case and then the antenna was tuned to heights from 1 meter to 4 meters and the rotatable table was turned from 0 degrees to 360 degrees to find the maximum reading.
- e. The test-receiver system was set to quasi-peak detect function and specified bandwidth with maximum hold mode when the test frequency is below 1 GHz.
- f. The test-receiver system was set to peak and average detect function and specified bandwidth with maximum hold mode when the test frequency is above 1 GHz. If the peak reading value also meets average limit, measurement with the average detector is unnecessary.

Note:

1. The resolution bandwidth and video bandwidth of test receiver/spectrum analyzer is 120kHz for Quasi-peak detection (QP) at frequency below 1GHz.
2. The resolution bandwidth of test receiver/spectrum analyzer is 1 MHz and the video bandwidth is 3 MHz for Peak detection (PK) at frequency above 1GHz.
3. The resolution bandwidth of test receiver/spectrum analyzer is 1MHz and the video bandwidth is $\geq 1/T$ (Duty cycle < 98%) or 10Hz (Duty cycle $\geq 98\%$) for Average detection (AV) at frequency above 1GHz.
(802.11a: RBW = 1MHz, VBW = 1kHz; 802.11ac (VHT20): RBW = 1MHz, VBW = 1kHz;
802.11ac (VHT40): RBW = 1MHz, VBW = 3kHz; 802.11ac (VHT80): RBW = 1MHz, VBW = 3kHz)
4. All modes of operation were investigated and the worst-case emissions are reported.

4.1.4 Deviation from Test Standard

No deviation.

4.1.5 Test Setup

For Radiated emission below 30MHz

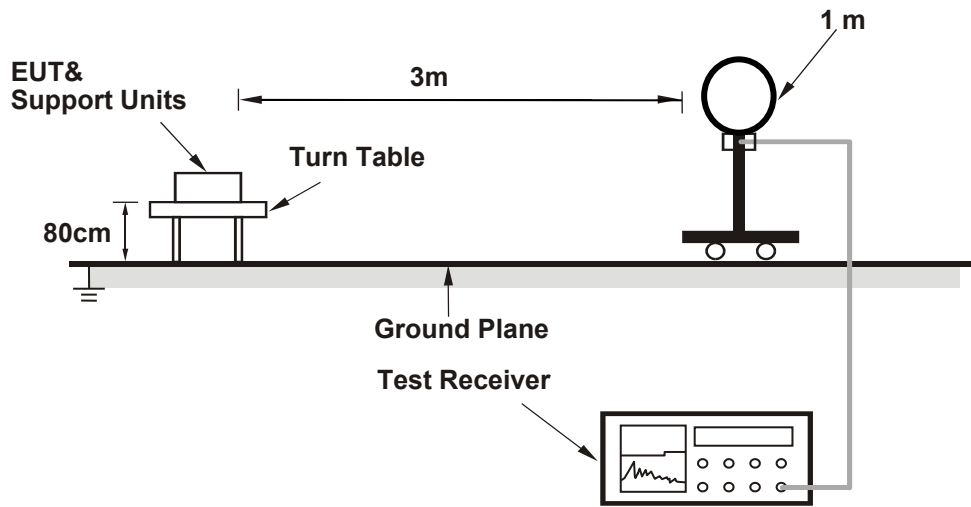

For Radiated emission 30MHz to 1GHz

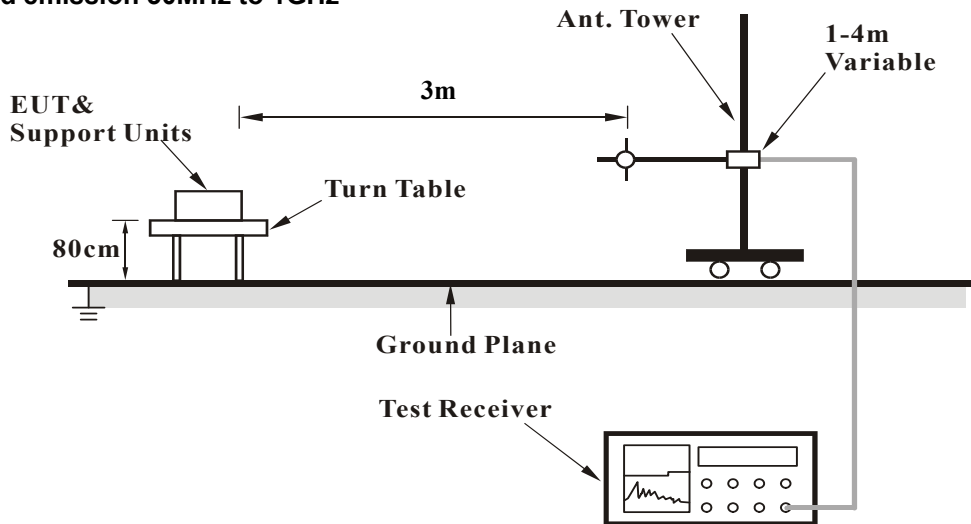

For Radiated emission above 1GHz

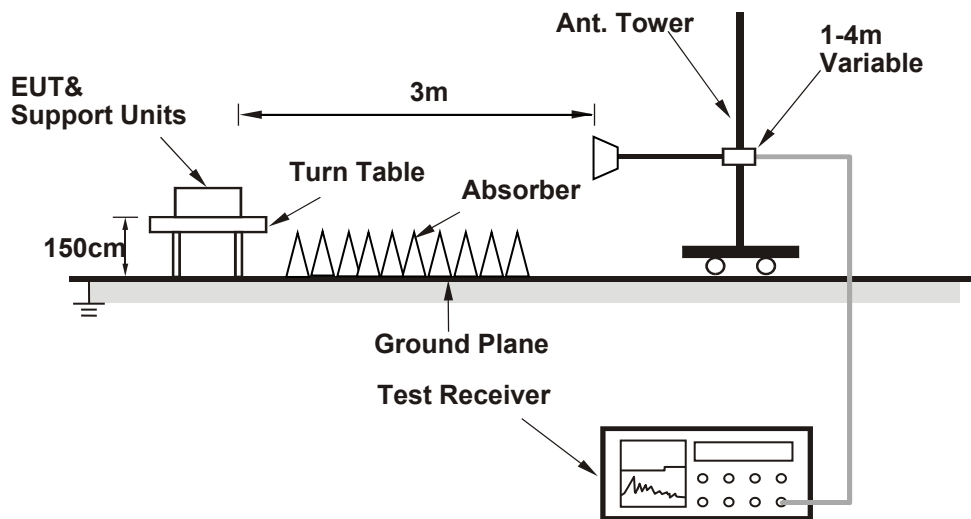

For the actual test configuration, please refer to the attached file (Test Setup Photo).

4.1.6 EUT Operating Conditions

- Placed the EUT on the testing table.
- The EUT under transmission condition continuously at specific channel frequency.

4.1.7 Test Results

Above 1GHz data:

RF Mode	TX 802.11a	Channel	CH 36 : 5180 MHz
Frequency Range	1GHz ~ 40GHz	Detector Function	Peak (PK) Average (AV)

Antenna Polarity & Test Distance : Horizontal at 3 m								
No	Frequency (MHz)	Emission Level (dBuV/m)	Limit (dBuV/m)	Margin (dB)	Antenna Height (m)	Table Angle (Degree)	Raw Value (dBuV)	Correction Factor (dB/m)
1	5150.00	52.9 PK	74.0	-21.1	1.35 H	200	50.8	2.1
2	5150.00	39.6 AV	54.0	-14.4	1.35 H	200	37.5	2.1
3	*5180.00	107.2 PK			1.29 H	178	70.8	36.4
4	*5180.00	97.1 AV			1.29 H	178	60.7	36.4
5	#10360.00	55.0 PK	68.2	-13.2	2.04 H	100	40.2	14.8

Antenna Polarity & Test Distance : Vertical at 3 m								
No	Frequency (MHz)	Emission Level (dBuV/m)	Limit (dBuV/m)	Margin (dB)	Antenna Height (m)	Table Angle (Degree)	Raw Value (dBuV)	Correction Factor (dB/m)
1	5150.00	53.5 PK	74.0	-20.5	1.88 V	221	51.4	2.1
2	5150.00	40.0 AV	54.0	-14.0	1.88 V	221	37.9	2.1
3	*5180.00	109.4 PK			1.80 V	203	73.0	36.4
4	*5180.00	99.4 AV			1.80 V	203	63.0	36.4
5	#10360.00	55.5 PK	68.2	-12.7	1.36 V	58	40.7	14.8

Remarks:

1. Emission Level(dBuV/m) = Raw Value(dBuV) + Correction Factor(dB/m)
2. Correction Factor(dB/m) = Antenna Factor(dB/m) + Cable Factor(dB) – Pre-Amplifier Factor(dB)
3. Margin value = Emission Level – Limit value
4. The other emission levels were very low against the limit.
5. " * ": Fundamental frequency.
6. " # ": The radiated frequency is out of the restricted band.

RF Mode	TX 802.11a	Channel	CH 40 : 5200 MHz
Frequency Range	1GHz ~ 40GHz	Detector Function	Peak (PK) Average (AV)

Antenna Polarity & Test Distance : Horizontal at 3 m

No	Frequency (MHz)	Emission Level (dBuV/m)	Limit (dBuV/m)	Margin (dB)	Antenna Height (m)	Table Angle (Degree)	Raw Value (dBuV)	Correction Factor (dB/m)
1	*5200.00	107.2 PK			1.87 H	223	70.8	36.4
2	*5200.00	97.5 AV			1.87 H	223	61.1	36.4
3	#10400.00	55.5 PK	68.2	-12.7	2.05 H	103	40.6	14.9

Antenna Polarity & Test Distance : Vertical at 3 m

No	Frequency (MHz)	Emission Level (dBuV/m)	Limit (dBuV/m)	Margin (dB)	Antenna Height (m)	Table Angle (Degree)	Raw Value (dBuV)	Correction Factor (dB/m)
1	*5200.00	109.3 PK			1.90 V	203	72.9	36.4
2	*5200.00	99.6 AV			1.90 V	203	63.2	36.4
3	#10400.00	55.4 PK	68.2	-12.8	1.33 V	66	40.5	14.9

Remarks:

1. Emission Level(dBuV/m) = Raw Value(dBuV) + Correction Factor(dB/m)
2. Correction Factor(dB/m) = Antenna Factor(dB/m) + Cable Factor(dB) – Pre-Amplifier Factor(dB)
3. Margin value = Emission Level – Limit value
4. The other emission levels were very low against the limit.
5. " * ": Fundamental frequency.
6. " # ": The radiated frequency is out of the restricted band.

RF Mode	TX 802.11a	Channel	CH 48 : 5240 MHz
Frequency Range	1GHz ~ 40GHz	Detector Function	Peak (PK) Average (AV)

Antenna Polarity & Test Distance : Horizontal at 3 m

No	Frequency (MHz)	Emission Level (dBuV/m)	Limit (dBuV/m)	Margin (dB)	Antenna Height (m)	Table Angle (Degree)	Raw Value (dBuV)	Correction Factor (dB/m)
1	*5240.00	107.1 PK			1.32 H	204	70.8	36.3
2	*5240.00	96.9 AV			1.32 H	204	60.6	36.3
3	5350.00	51.7 PK	74.0	-22.3	1.28 H	188	49.7	2.0
4	5350.00	38.5 AV	54.0	-15.5	1.28 H	188	36.5	2.0
5	#10480.00	55.3 PK	68.2	-12.9	1.96 H	98	40.4	14.9
6	#10480.00	45.4 AV	54.0	-8.6	1.15 H	31	30.3	15.1

Antenna Polarity & Test Distance : Vertical at 3 m

No	Frequency (MHz)	Emission Level (dBuV/m)	Limit (dBuV/m)	Margin (dB)	Antenna Height (m)	Table Angle (Degree)	Raw Value (dBuV)	Correction Factor (dB/m)
1	*5240.00	109.0 PK			1.91 V	205	72.7	36.3
2	*5240.00	98.5 AV			1.91 V	205	62.2	36.3
3	5350.00	51.9 PK	74.0	-22.1	1.96 V	198	49.9	2.0
4	5350.00	38.5 AV	54.0	-15.5	1.96 V	198	36.5	2.0
5	#10480.00	55.9 PK	68.2	-12.3	1.38 V	55	41.0	14.9

Remarks:

1. Emission Level(dBuV/m) = Raw Value(dBuV) + Correction Factor(dB/m)
2. Correction Factor(dB/m) = Antenna Factor(dB/m) + Cable Factor(dB) – Pre-Amplifier Factor(dB)
3. Margin value = Emission Level – Limit value
4. The other emission levels were very low against the limit.
5. " * " : Fundamental frequency.
6. " # " : The radiated frequency is out of the restricted band.

RF Mode	TX 802.11a	Channel	CH 52 : 5260 MHz
Frequency Range	1GHz ~ 40GHz	Detector Function	Peak (PK) Average (AV)

Antenna Polarity & Test Distance : Horizontal at 3 m

No	Frequency (MHz)	Emission Level (dBuV/m)	Limit (dBuV/m)	Margin (dB)	Antenna Height (m)	Table Angle (Degree)	Raw Value (dBuV)	Correction Factor (dB/m)
1	5150.00	52.2 PK	74.0	-21.8	1.43 H	196	50.1	2.1
2	5150.00	38.8 AV	54.0	-15.2	1.43 H	196	36.7	2.1
3	*5260.00	106.7 PK			1.47 H	202	70.5	36.2
4	*5260.00	96.7 AV			1.47 H	202	60.5	36.2
5	#10520.00	55.8 PK	68.2	-12.4	1.88 H	97	40.8	15.0

Antenna Polarity & Test Distance : Vertical at 3 m

No	Frequency (MHz)	Emission Level (dBuV/m)	Limit (dBuV/m)	Margin (dB)	Antenna Height (m)	Table Angle (Degree)	Raw Value (dBuV)	Correction Factor (dB/m)
1	5150.00	52.4 PK	74.0	-21.6	1.99 V	206	50.3	2.1
2	5150.00	38.9 AV	54.0	-15.1	1.99 V	206	36.8	2.1
3	*5260.00	107.7 PK			1.98 V	205	71.5	36.2
4	*5260.00	98.0 AV			1.98 V	205	61.8	36.2
5	#10520.00	56.2 PK	68.2	-12.0	1.37 V	63	41.2	15.0

Remarks:

1. Emission Level(dBuV/m) = Raw Value(dBuV) + Correction Factor(dB/m)
2. Correction Factor(dB/m) = Antenna Factor(dB/m) + Cable Factor(dB) – Pre-Amplifier Factor(dB)
3. Margin value = Emission Level – Limit value
4. The other emission levels were very low against the limit.
5. " * " : Fundamental frequency.
6. " # " : The radiated frequency is out of the restricted band.

RF Mode	TX 802.11a	Channel	CH 60 : 5300 MHz
Frequency Range	1GHz ~ 40GHz	Detector Function	Peak (PK) Average (AV)

Antenna Polarity & Test Distance : Horizontal at 3 m

No	Frequency (MHz)	Emission Level (dBuV/m)	Limit (dBuV/m)	Margin (dB)	Antenna Height (m)	Table Angle (Degree)	Raw Value (dBuV)	Correction Factor (dB/m)
1	*5300.00	106.1 PK			1.33 H	205	70.1	36.0
2	*5300.00	97.3 AV			1.33 H	205	61.3	36.0
3	10600.00	56.1 PK	74.0	-17.9	1.92 H	103	40.5	15.6
4	10600.00	42.5 AV	54.0	-11.5	1.92 H	103	26.9	15.6

Antenna Polarity & Test Distance : Vertical at 3 m

No	Frequency (MHz)	Emission Level (dBuV/m)	Limit (dBuV/m)	Margin (dB)	Antenna Height (m)	Table Angle (Degree)	Raw Value (dBuV)	Correction Factor (dB/m)
1	*5300.00	107.3 PK			2.19 V	203	71.3	36.0
2	*5300.00	98.1 AV			2.19 V	203	62.1	36.0
3	10600.00	56.4 PK	74.0	-17.6	1.45 V	52	40.8	15.6
4	10600.00	43.1 AV	54.0	-10.9	1.45 V	52	27.5	15.6

Remarks:

1. Emission Level(dBuV/m) = Raw Value(dBuV) + Correction Factor(dB/m)
2. Correction Factor(dB/m) = Antenna Factor(dB/m) + Cable Factor(dB) – Pre-Amplifier Factor(dB)
3. Margin value = Emission Level – Limit value
4. The other emission levels were very low against the limit.
5. " * " : Fundamental frequency.

RF Mode	TX 802.11a	Channel	CH 64 : 5320 MHz
Frequency Range	1GHz ~ 40GHz	Detector Function	Peak (PK) Average (AV)

Antenna Polarity & Test Distance : Horizontal at 3 m

No	Frequency (MHz)	Emission Level (dBuV/m)	Limit (dBuV/m)	Margin (dB)	Antenna Height (m)	Table Angle (Degree)	Raw Value (dBuV)	Correction Factor (dB/m)
1	*5320.00	105.9 PK			1.48 H	207	69.7	36.2
2	*5320.00	96.0 AV			1.48 H	207	59.8	36.2
3	5350.00	54.8 PK	74.0	-19.2	1.35 H	184	52.8	2.0
4	5350.00	39.4 AV	54.0	-14.6	1.35 H	184	37.4	2.0
5	10640.00	56.1 PK	74.0	-17.9	2.01 H	105	40.5	15.6
6	10640.00	42.6 AV	54.0	-11.4	2.01 H	105	27.0	15.6

Antenna Polarity & Test Distance : Vertical at 3 m

No	Frequency (MHz)	Emission Level (dBuV/m)	Limit (dBuV/m)	Margin (dB)	Antenna Height (m)	Table Angle (Degree)	Raw Value (dBuV)	Correction Factor (dB/m)
1	*5320.00	107.1 PK			2.20 V	206	70.9	36.2
2	*5320.00	97.6 AV			2.20 V	206	61.4	36.2
3	5350.00	55.0 PK	74.0	-19.0	2.11 V	217	53.0	2.0
4	5350.00	39.4 AV	54.0	-14.6	2.11 V	217	37.4	2.0
5	10640.00	56.3 PK	74.0	-17.7	1.39 V	48	40.7	15.6
6	10640.00	42.8 AV	54.0	-11.2	1.39 V	48	27.2	15.6

Remarks:

1. Emission Level(dBuV/m) = Raw Value(dBuV) + Correction Factor(dB/m)
2. Correction Factor(dB/m) = Antenna Factor(dB/m) + Cable Factor(dB) – Pre-Amplifier Factor(dB)
3. Margin value = Emission Level – Limit value
4. The other emission levels were very low against the limit.
5. " * ": Fundamental frequency.

RF Mode	TX 802.11a	Channel	CH 100 : 5500 MHz
Frequency Range	1GHz ~ 40GHz	Detector Function	Peak (PK) Average (AV)

Antenna Polarity & Test Distance : Horizontal at 3 m

No	Frequency (MHz)	Emission Level (dBuV/m)	Limit (dBuV/m)	Margin (dB)	Antenna Height (m)	Table Angle (Degree)	Raw Value (dBuV)	Correction Factor (dB/m)
1	5460.00	53.5 PK	74.0	-20.5	1.37 H	288	50.9	2.6
2	5460.00	39.6 AV	54.0	-14.4	1.37 H	288	37.0	2.6
3	#5470.00	53.7 PK	68.2	-14.5	1.37 H	288	51.1	2.6
4	*5500.00	104.9 PK			1.33 H	297	67.9	37.0
5	*5500.00	95.4 AV			1.33 H	297	58.4	37.0
6	11000.00	56.7 PK	74.0	-17.3	1.94 H	98	40.2	16.5
7	11000.00	43.8 AV	54.0	-10.2	1.94 H	98	27.3	16.5

Antenna Polarity & Test Distance : Vertical at 3 m

No	Frequency (MHz)	Emission Level (dBuV/m)	Limit (dBuV/m)	Margin (dB)	Antenna Height (m)	Table Angle (Degree)	Raw Value (dBuV)	Correction Factor (dB/m)
1	5460.00	57.4 PK	74.0	-16.6	2.18 V	266	54.8	2.6
2	5460.00	40.3 AV	54.0	-13.7	2.18 V	266	37.7	2.6
3	#5470.00	58.4 PK	68.2	-9.8	2.18 V	266	55.8	2.6
4	*5500.00	108.3 PK			2.25 V	279	71.3	37.0
5	*5500.00	98.7 AV			2.25 V	279	61.7	37.0
6	11000.00	57.2 PK	74.0	-16.8	1.45 V	63	40.7	16.5
7	11000.00	43.8 AV	54.0	-10.2	1.45 V	63	27.3	16.5

Remarks:

1. Emission Level(dBuV/m) = Raw Value(dBuV) + Correction Factor(dB/m)
2. Correction Factor(dB/m) = Antenna Factor(dB/m) + Cable Factor(dB) – Pre-Amplifier Factor(dB)
3. Margin value = Emission Level – Limit value
4. The other emission levels were very low against the limit.
5. " * ": Fundamental frequency.
6. " # ": The radiated frequency is out of the restricted band.

RF Mode	TX 802.11a	Channel	CH 116 : 5580 MHz
Frequency Range	1GHz ~ 40GHz	Detector Function	Peak (PK) Average (AV)

Antenna Polarity & Test Distance : Horizontal at 3 m

No	Frequency (MHz)	Emission Level (dBuV/m)	Limit (dBuV/m)	Margin (dB)	Antenna Height (m)	Table Angle (Degree)	Raw Value (dBuV)	Correction Factor (dB/m)
1	*5580.00	104.7 PK			1.36 H	279	67.7	37.0
2	*5580.00	95.2 AV			1.36 H	279	58.2	37.0
3	11160.00	56.4 PK	74.0	-17.6	1.97 H	104	40.6	15.8
4	11160.00	43.4 AV	54.0	-10.6	1.97 H	104	27.6	15.8

Antenna Polarity & Test Distance : Vertical at 3 m

No	Frequency (MHz)	Emission Level (dBuV/m)	Limit (dBuV/m)	Margin (dB)	Antenna Height (m)	Table Angle (Degree)	Raw Value (dBuV)	Correction Factor (dB/m)
1	*5580.00	108.6 PK			2.52 V	273	71.6	37.0
2	*5580.00	98.0 AV			2.52 V	273	61.0	37.0
3	11160.00	56.3 PK	74.0	-17.7	1.47 V	71	40.5	15.8
4	11160.00	43.3 AV	54.0	-10.7	1.47 V	71	27.5	15.8

Remarks:

1. Emission Level(dBuV/m) = Raw Value(dBuV) + Correction Factor(dB/m)
2. Correction Factor(dB/m) = Antenna Factor(dB/m) + Cable Factor(dB) – Pre-Amplifier Factor(dB)
3. Margin value = Emission Level – Limit value
4. The other emission levels were very low against the limit.
5. " * ": Fundamental frequency.

RF Mode	TX 802.11a	Channel	CH 140 : 5700 MHz
Frequency Range	1GHz ~ 40GHz	Detector Function	Peak (PK) Average (AV)

Antenna Polarity & Test Distance : Horizontal at 3 m

No	Frequency (MHz)	Emission Level (dBuV/m)	Limit (dBuV/m)	Margin (dB)	Antenna Height (m)	Table Angle (Degree)	Raw Value (dBuV)	Correction Factor (dB/m)
1	*5700.00	107.0 PK			1.47 H	285	69.8	37.2
2	*5700.00	96.8 AV			1.47 H	285	59.6	37.2
3	#5725.00	54.5 PK	68.2	-13.7	1.36 H	296	51.5	3.0
4	11400.00	57.8 PK	74.0	-16.2	1.99 H	91	41.3	16.5
5	11400.00	43.9 AV	54.0	-10.1	1.99 H	91	27.4	16.5

Antenna Polarity & Test Distance : Vertical at 3 m

No	Frequency (MHz)	Emission Level (dBuV/m)	Limit (dBuV/m)	Margin (dB)	Antenna Height (m)	Table Angle (Degree)	Raw Value (dBuV)	Correction Factor (dB/m)
1	*5700.00	110.1 PK			2.36 V	271	72.9	37.2
2	*5700.00	99.5 AV			2.36 V	271	62.3	37.2
3	#5725.00	54.8 PK	68.2	-13.4	2.44 V	268	51.8	3.0
4	11400.00	57.3 PK	74.0	-16.7	1.46 V	58	40.8	16.5
5	11400.00	44.3 AV	54.0	-9.7	1.46 V	58	27.8	16.5

Remarks:

1. Emission Level(dBuV/m) = Raw Value(dBuV) + Correction Factor(dB/m)
2. Correction Factor(dB/m) = Antenna Factor(dB/m) + Cable Factor(dB) – Pre-Amplifier Factor(dB)
3. Margin value = Emission Level – Limit value
4. The other emission levels were very low against the limit.
5. " * " : Fundamental frequency.
6. " # " : The radiated frequency is out of the restricted band.

RF Mode	TX 802.11a	Channel	CH 144 : 5720 MHz
Frequency Range	1GHz ~ 40GHz	Detector Function	Peak (PK) Average (AV)

Antenna Polarity & Test Distance : Horizontal at 3 m

No	Frequency (MHz)	Emission Level (dBuV/m)	Limit (dBuV/m)	Margin (dB)	Antenna Height (m)	Table Angle (Degree)	Raw Value (dBuV)	Correction Factor (dB/m)
1	*5720.00	108.3 PK			1.42 H	283	71.0	37.3
2	*5720.00	97.5 AV			1.42 H	283	60.2	37.3
3	#5850.00	53.6 PK	68.2	-14.6	1.34 H	292	50.1	3.5
4	11440.00	56.6 PK	74.0	-17.4	1.91 H	106	40.3	16.3
5	11440.00	43.7 AV	54.0	-10.3	1.91 H	106	27.4	16.3

Antenna Polarity & Test Distance : Vertical at 3 m

No	Frequency (MHz)	Emission Level (dBuV/m)	Limit (dBuV/m)	Margin (dB)	Antenna Height (m)	Table Angle (Degree)	Raw Value (dBuV)	Correction Factor (dB/m)
1	*5720.00	110.8 PK			2.29 V	279	73.5	37.3
2	*5720.00	100.2 AV			2.29 V	279	62.9	37.3
3	#5850.00	53.7 PK	68.2	-14.5	2.21 V	287	50.2	3.5
4	11440.00	57.1 PK	74.0	-16.9	1.35 V	60	40.8	16.3
5	11440.00	43.9 AV	54.0	-10.1	1.35 V	60	27.6	16.3

Remarks:

1. Emission Level(dBuV/m) = Raw Value(dBuV) + Correction Factor(dB/m)
2. Correction Factor(dB/m) = Antenna Factor(dB/m) + Cable Factor(dB) – Pre-Amplifier Factor(dB)
3. Margin value = Emission Level – Limit value
4. The other emission levels were very low against the limit.
5. " * " : Fundamental frequency.
6. " # " : The radiated frequency is out of the restricted band.

RF Mode	TX 802.11a	Channel	CH 149 : 5745 MHz
Frequency Range	1GHz ~ 40GHz	Detector Function	Peak (PK) Average (AV)

Antenna Polarity & Test Distance : Horizontal at 3 m

No	Frequency (MHz)	Emission Level (dBuV/m)	Limit (dBuV/m)	Margin (dB)	Antenna Height (m)	Table Angle (Degree)	Raw Value (dBuV)	Correction Factor (dB/m)
1	#5650.00	50.6 PK	68.2	-17.6	1.31 H	273	47.8	2.8
2	*5745.00	106.5 PK			1.14 H	294	69.2	37.3
3	*5745.00	96.1 AV			1.14 H	294	58.8	37.3
4	#5983.60	52.0 PK	68.2	-16.2	1.31 H	273	48.6	3.4
5	11490.00	54.8 PK	74.0	-19.2	1.93 H	104	38.6	16.2
6	11490.00	42.5 AV	54.0	-11.5	1.93 H	104	26.3	16.2

Antenna Polarity & Test Distance : Vertical at 3 m

No	Frequency (MHz)	Emission Level (dBuV/m)	Limit (dBuV/m)	Margin (dB)	Antenna Height (m)	Table Angle (Degree)	Raw Value (dBuV)	Correction Factor (dB/m)
1	#5642.00	51.2 PK	68.2	-17.0	2.29 V	254	48.4	2.8
2	*5745.00	110.2 PK			2.19 V	280	72.9	37.3
3	*5745.00	101.0 AV			2.19 V	280	63.7	37.3
4	#5958.00	51.8 PK	68.2	-16.4	2.29 V	254	48.4	3.4
5	11490.00	57.4 PK	74.0	-16.6	1.38 V	47	41.2	16.2
6	11490.00	42.9 AV	54.0	-11.1	1.38 V	47	26.7	16.2

Remarks:

1. Emission Level(dBuV/m) = Raw Value(dBuV) + Correction Factor(dB/m)
2. Correction Factor(dB/m) = Antenna Factor(dB/m) + Cable Factor(dB) – Pre-Amplifier Factor(dB)
3. Margin value = Emission Level – Limit value
4. The other emission levels were very low against the limit.
5. " * " : Fundamental frequency.
6. " # " : The radiated frequency is out of the restricted band.

RF Mode	TX 802.11a	Channel	CH 157 : 5785 MHz
Frequency Range	1GHz ~ 40GHz	Detector Function	Peak (PK) Average (AV)

Antenna Polarity & Test Distance : Horizontal at 3 m

No	Frequency (MHz)	Emission Level (dBuV/m)	Limit (dBuV/m)	Margin (dB)	Antenna Height (m)	Table Angle (Degree)	Raw Value (dBuV)	Correction Factor (dB/m)
1	#5644.40	51.4 PK	68.2	-16.8	1.04 H	279	48.6	2.8
2	*5785.00	105.8 PK			1.00 H	296	68.3	37.5
3	*5785.00	95.6 AV			1.00 H	296	58.1	37.5
4	#5990.40	52.6 PK	68.2	-15.6	1.04 H	279	49.2	3.4
5	11570.00	55.1 PK	74.0	-18.9	1.96 H	107	39.1	16.0
6	11570.00	42.4 AV	54.0	-11.6	1.96 H	107	26.4	16.0

Antenna Polarity & Test Distance : Vertical at 3 m

No	Frequency (MHz)	Emission Level (dBuV/m)	Limit (dBuV/m)	Margin (dB)	Antenna Height (m)	Table Angle (Degree)	Raw Value (dBuV)	Correction Factor (dB/m)
1	#5640.40	51.4 PK	68.2	-16.8	2.46 V	282	48.6	2.8
2	*5785.00	109.7 PK			2.33 V	272	72.2	37.5
3	*5785.00	99.8 AV			2.33 V	272	62.3	37.5
4	#5926.40	52.4 PK	68.2	-15.8	2.46 V	282	49.0	3.4
5	11570.00	56.1 PK	74.0	-17.9	1.28 V	62	40.1	16.0
6	11570.00	42.2 AV	54.0	-11.8	1.28 V	62	26.2	16.0

Remarks:

1. Emission Level(dBuV/m) = Raw Value(dBuV) + Correction Factor(dB/m)
2. Correction Factor(dB/m) = Antenna Factor(dB/m) + Cable Factor(dB) – Pre-Amplifier Factor(dB)
3. Margin value = Emission Level – Limit value
4. The other emission levels were very low against the limit.
5. " * " : Fundamental frequency.
6. " # " : The radiated frequency is out of the restricted band.

RF Mode	TX 802.11a	Channel	CH 165 : 5825 MHz
Frequency Range	1GHz ~ 40GHz	Detector Function	Peak (PK) Average (AV)

Antenna Polarity & Test Distance : Horizontal at 3 m

No	Frequency (MHz)	Emission Level (dBuV/m)	Limit (dBuV/m)	Margin (dB)	Antenna Height (m)	Table Angle (Degree)	Raw Value (dBuV)	Correction Factor (dB/m)
1	#5613.20	51.4 PK	68.2	-16.8	1.18 H	286	48.6	2.8
2	*5825.00	104.8 PK			1.00 H	294	67.2	37.6
3	*5825.00	94.6 AV			1.00 H	294	57.0	37.6
4	#5937.60	52.2 PK	68.2	-16.0	1.18 H	286	48.7	3.5
5	11650.00	54.6 PK	74.0	-19.4	1.91 H	100	38.6	16.0
6	11650.00	42.3 AV	54.0	-11.7	1.91 H	100	26.3	16.0

Antenna Polarity & Test Distance : Vertical at 3 m

No	Frequency (MHz)	Emission Level (dBuV/m)	Limit (dBuV/m)	Margin (dB)	Antenna Height (m)	Table Angle (Degree)	Raw Value (dBuV)	Correction Factor (dB/m)
1	#5634.80	50.8 PK	68.2	-17.4	2.19 V	283	48.1	2.7
2	*5825.00	110.1 PK			2.32 V	275	72.5	37.6
3	*5825.00	99.6 AV			2.32 V	275	62.0	37.6
4	#5980.40	52.1 PK	68.2	-16.1	2.19 V	283	48.7	3.4
5	11650.00	55.8 PK	74.0	-18.2	1.43 V	42	39.8	16.0
6	11650.00	42.7 AV	54.0	-11.3	1.43 V	42	26.7	16.0

Remarks:

1. Emission Level(dBuV/m) = Raw Value(dBuV) + Correction Factor(dB/m)
2. Correction Factor(dB/m) = Antenna Factor(dB/m) + Cable Factor(dB) – Pre-Amplifier Factor(dB)
3. Margin value = Emission Level – Limit value
4. The other emission levels were very low against the limit.
5. " * " : Fundamental frequency.
6. " # " : The radiated frequency is out of the restricted band.

RF Mode	TX 802.11ac (VHT20)	Channel	CH 36 : 5180 MHz
Frequency Range	1GHz ~ 40GHz	Detector Function	Peak (PK) Average (AV)

Antenna Polarity & Test Distance : Horizontal at 3 m

No	Frequency (MHz)	Emission Level (dBuV/m)	Limit (dBuV/m)	Margin (dB)	Antenna Height (m)	Table Angle (Degree)	Raw Value (dBuV)	Correction Factor (dB/m)
1	5150.00	56.6 PK	74.0	-17.4	1.25 H	208	54.5	2.1
2	5150.00	39.3 AV	54.0	-14.7	1.25 H	208	37.2	2.1
3	*5180.00	104.7 PK			1.27 H	201	68.3	36.4
4	*5180.00	94.9 AV			1.27 H	201	58.5	36.4
5	#10360.00	55.1 PK	68.2	-13.1	1.97 H	95	40.3	14.8

Antenna Polarity & Test Distance : Vertical at 3 m

No	Frequency (MHz)	Emission Level (dBuV/m)	Limit (dBuV/m)	Margin (dB)	Antenna Height (m)	Table Angle (Degree)	Raw Value (dBuV)	Correction Factor (dB/m)
1	5150.00	57.4 PK	74.0	-16.6	1.84 V	211	55.3	2.1
2	5150.00	39.9 AV	54.0	-14.1	1.84 V	211	37.8	2.1
3	*5180.00	107.0 PK			1.80 V	200	70.6	36.4
4	*5180.00	96.7 AV			1.80 V	200	60.3	36.4
5	#10360.00	55.3 PK	68.2	-12.9	1.37 V	62	40.5	14.8

Remarks:

1. Emission Level(dBuV/m) = Raw Value(dBuV) + Correction Factor(dB/m)
2. Correction Factor(dB/m) = Antenna Factor(dB/m) + Cable Factor(dB) – Pre-Amplifier Factor(dB)
3. Margin value = Emission Level – Limit value
4. The other emission levels were very low against the limit.
5. " * " : Fundamental frequency.
6. " # " : The radiated frequency is out of the restricted band.

RF Mode	TX 802.11ac (VHT20)	Channel	CH 40 : 5200 MHz
Frequency Range	1GHz ~ 40GHz	Detector Function	Peak (PK) Average (AV)

Antenna Polarity & Test Distance : Horizontal at 3 m

No	Frequency (MHz)	Emission Level (dBuV/m)	Limit (dBuV/m)	Margin (dB)	Antenna Height (m)	Table Angle (Degree)	Raw Value (dBuV)	Correction Factor (dB/m)
1	*5200.00	105.2 PK			1.36 H	204	68.8	36.4
2	*5200.00	95.2 AV			1.36 H	207	58.8	36.4
3	#10400.00	55.9 PK	68.2	-12.3	2.02 H	55	41.0	14.9

Antenna Polarity & Test Distance : Vertical at 3 m

No	Frequency (MHz)	Emission Level (dBuV/m)	Limit (dBuV/m)	Margin (dB)	Antenna Height (m)	Table Angle (Degree)	Raw Value (dBuV)	Correction Factor (dB/m)
1	*5200.00	107.3 PK			1.89 V	201	70.9	36.4
2	*5200.00	97.3 AV			1.89 V	201	60.9	36.4
3	#10400.00	56.2 PK	68.2	-12.0	1.36 V	55	41.3	14.9

Remarks:

1. Emission Level(dBuV/m) = Raw Value(dBuV) + Correction Factor(dB/m)
2. Correction Factor(dB/m) = Antenna Factor(dB/m) + Cable Factor(dB) – Pre-Amplifier Factor(dB)
3. Margin value = Emission Level – Limit value
4. The other emission levels were very low against the limit.
5. " * ": Fundamental frequency.
6. " # ": The radiated frequency is out of the restricted band.

RF Mode	TX 802.11ac (VHT20)	Channel	CH 48 : 5240 MHz
Frequency Range	1GHz ~ 40GHz	Detector Function	Peak (PK) Average (AV)

Antenna Polarity & Test Distance : Horizontal at 3 m

No	Frequency (MHz)	Emission Level (dBuV/m)	Limit (dBuV/m)	Margin (dB)	Antenna Height (m)	Table Angle (Degree)	Raw Value (dBuV)	Correction Factor (dB/m)
1	*5240.00	104.5 PK			1.44 H	208	68.2	36.3
2	*5240.00	94.3 AV			1.44 H	208	58.0	36.3
3	5350.00	51.8 PK	74.0	-22.2	1.31 H	196	49.8	2.0
4	5350.00	40.2 AV	54.0	-13.8	1.31 H	196	38.2	2.0
5	#10480.00	55.5 PK	68.2	-12.7	2.00 H	101	40.6	14.9

Antenna Polarity & Test Distance : Vertical at 3 m

No	Frequency (MHz)	Emission Level (dBuV/m)	Limit (dBuV/m)	Margin (dB)	Antenna Height (m)	Table Angle (Degree)	Raw Value (dBuV)	Correction Factor (dB/m)
1	*5240.00	106.7 PK			1.90 V	205	70.4	36.3
2	*5240.00	96.3 AV			1.90 V	205	60.0	36.3
3	5350.00	52.8 PK	74.0	-21.2	1.95 V	220	50.8	2.0
4	5350.00	39.0 AV	54.0	-15.0	1.95 V	220	37.0	2.0
5	#10480.00	55.6 PK	68.2	-12.6	1.34 V	59	40.7	14.9

Remarks:

1. Emission Level(dBuV/m) = Raw Value(dBuV) + Correction Factor(dB/m)
2. Correction Factor(dB/m) = Antenna Factor(dB/m) + Cable Factor(dB) – Pre-Amplifier Factor(dB)
3. Margin value = Emission Level – Limit value
4. The other emission levels were very low against the limit.
5. " * " : Fundamental frequency.
6. " # " : The radiated frequency is out of the restricted band.

RF Mode	TX 802.11ac (VHT20)	Channel	CH 52 : 5260 MHz
Frequency Range	1GHz ~ 40GHz	Detector Function	Peak (PK) Average (AV)

Antenna Polarity & Test Distance : Horizontal at 3 m

No	Frequency (MHz)	Emission Level (dBuV/m)	Limit (dBuV/m)	Margin (dB)	Antenna Height (m)	Table Angle (Degree)	Raw Value (dBuV)	Correction Factor (dB/m)
1	5150.00	51.6 PK	74.0	-22.4	1.33 H	200	49.5	2.1
2	5150.00	38.5 AV	54.0	-15.5	1.33 H	200	36.4	2.1
3	*5260.00	105.0 PK			1.41 H	205	68.8	36.2
4	*5260.00	95.1 AV			1.41 H	205	58.9	36.2
5	#10520.00	55.7 PK	68.2	-12.5	1.95 H	88	40.7	15.0

Antenna Polarity & Test Distance : Vertical at 3 m

No	Frequency (MHz)	Emission Level (dBuV/m)	Limit (dBuV/m)	Margin (dB)	Antenna Height (m)	Table Angle (Degree)	Raw Value (dBuV)	Correction Factor (dB/m)
1	5150.00	51.5 PK	74.0	-22.5	2.17 V	202	49.4	2.1
2	5150.00	38.4 AV	54.0	-15.6	2.17 V	202	36.3	2.1
3	*5260.00	106.6 PK			2.25 V	205	70.4	36.2
4	*5260.00	96.6 AV			2.25 V	205	60.4	36.2
5	#10520.00	55.9 PK	68.2	-12.3	1.38 V	66	40.9	15.0

Remarks:

1. Emission Level(dBuV/m) = Raw Value(dBuV) + Correction Factor(dB/m)
2. Correction Factor(dB/m) = Antenna Factor(dB/m) + Cable Factor(dB) – Pre-Amplifier Factor(dB)
3. Margin value = Emission Level – Limit value
4. The other emission levels were very low against the limit.
5. " * " : Fundamental frequency.
6. " # " : The radiated frequency is out of the restricted band.

RF Mode	TX 802.11ac (VHT20)	Channel	CH 60 : 5300 MHz
Frequency Range	1GHz ~ 40GHz	Detector Function	Peak (PK) Average (AV)

Antenna Polarity & Test Distance : Horizontal at 3 m

No	Frequency (MHz)	Emission Level (dBuV/m)	Limit (dBuV/m)	Margin (dB)	Antenna Height (m)	Table Angle (Degree)	Raw Value (dBuV)	Correction Factor (dB/m)
1	*5300.00	103.4 PK			1.32 H	201	67.4	36.0
2	*5300.00	93.9 AV			1.32 H	201	57.9	36.0
3	10600.00	56.2 PK	74.0	-17.8	1.96 H	94	40.6	15.6
4	10600.00	42.7 AV	54.0	-11.3	1.96 H	94	27.1	15.6

Antenna Polarity & Test Distance : Vertical at 3 m

No	Frequency (MHz)	Emission Level (dBuV/m)	Limit (dBuV/m)	Margin (dB)	Antenna Height (m)	Table Angle (Degree)	Raw Value (dBuV)	Correction Factor (dB/m)
1	*5300.00	104.5 PK			2.26 V	200	68.5	36.0
2	*5300.00	95.0 AV			2.26 V	200	59.0	36.0
3	10600.00	56.3 PK	74.0	-17.7	1.39 V	62	40.7	15.6
4	10600.00	42.8 AV	54.0	-11.2	1.39 V	62	27.2	15.6

Remarks:

1. Emission Level(dBuV/m) = Raw Value(dBuV) + Correction Factor(dB/m)
2. Correction Factor(dB/m) = Antenna Factor(dB/m) + Cable Factor(dB) – Pre-Amplifier Factor(dB)
3. Margin value = Emission Level – Limit value
4. The other emission levels were very low against the limit.
5. " * " : Fundamental frequency.

RF Mode	TX 802.11ac (VHT20)	Channel	CH 64 : 5320 MHz
Frequency Range	1GHz ~ 40GHz	Detector Function	Peak (PK) Average (AV)

Antenna Polarity & Test Distance : Horizontal at 3 m

No	Frequency (MHz)	Emission Level (dBuV/m)	Limit (dBuV/m)	Margin (dB)	Antenna Height (m)	Table Angle (Degree)	Raw Value (dBuV)	Correction Factor (dB/m)
1	*5320.00	103.0 PK			1.38 H	204	66.8	36.2
2	*5320.00	93.9 AV			1.38 H	204	57.7	36.2
3	5350.00	56.6 PK	74.0	-17.4	1.35 H	211	54.6	2.0
4	5350.00	39.3 AV	54.0	-14.7	1.35 H	211	37.3	2.0
5	10640.00	56.3 PK	74.0	-17.7	1.86 H	94	40.7	15.6
6	10640.00	42.6 AV	54.0	-11.4	1.86 H	94	27.0	15.6

Antenna Polarity & Test Distance : Vertical at 3 m

No	Frequency (MHz)	Emission Level (dBuV/m)	Limit (dBuV/m)	Margin (dB)	Antenna Height (m)	Table Angle (Degree)	Raw Value (dBuV)	Correction Factor (dB/m)
1	*5320.00	104.5 PK			1.80 V	203	68.3	36.2
2	*5320.00	95.4 AV			1.80 V	203	59.2	36.2
3	5350.00	57.3 PK	74.0	-16.7	1.84 V	205	55.3	2.0
4	5350.00	39.4 AV	54.0	-14.6	1.84 V	205	37.4	2.0
5	10640.00	56.4 PK	74.0	-17.6	1.99 V	101	40.8	15.6
6	10640.00	42.7 AV	54.0	-11.3	1.99 V	101	27.1	15.6

Remarks:

1. Emission Level(dBuV/m) = Raw Value(dBuV) + Correction Factor(dB/m)
2. Correction Factor(dB/m) = Antenna Factor(dB/m) + Cable Factor(dB) – Pre-Amplifier Factor(dB)
3. Margin value = Emission Level – Limit value
4. The other emission levels were very low against the limit.
5. " * ": Fundamental frequency.

RF Mode	TX 802.11ac (VHT20)	Channel	CH 100 : 5500 MHz
Frequency Range	1GHz ~ 40GHz	Detector Function	Peak (PK) Average (AV)

Antenna Polarity & Test Distance : Horizontal at 3 m

No	Frequency (MHz)	Emission Level (dBuV/m)	Limit (dBuV/m)	Margin (dB)	Antenna Height (m)	Table Angle (Degree)	Raw Value (dBuV)	Correction Factor (dB/m)
1	5460.00	53.4 PK	74.0	-20.6	1.46 H	296	50.8	2.6
2	5460.00	40.8 AV	54.0	-13.2	1.46 H	296	38.2	2.6
3	#5470.00	56.9 PK	68.2	-11.3	1.46 H	296	54.3	2.6
4	*5500.00	104.3 PK			1.37 H	281	67.3	37.0
5	*5500.00	94.3 AV			1.37 H	281	57.3	37.0
6	11000.00	57.0 PK	74.0	-17.0	1.87 H	104	40.5	16.5
7	11000.00	43.7 AV	54.0	-10.3	1.87 H	104	27.2	16.5

Antenna Polarity & Test Distance : Vertical at 3 m

No	Frequency (MHz)	Emission Level (dBuV/m)	Limit (dBuV/m)	Margin (dB)	Antenna Height (m)	Table Angle (Degree)	Raw Value (dBuV)	Correction Factor (dB/m)
1	5460.00	54.2 PK	74.0	-19.8	2.06 V	277	51.6	2.6
2	5460.00	41.0 AV	54.0	-13.0	2.06 V	277	38.4	2.6
3	#5470.00	58.1 PK	68.2	-10.1	2.06 V	277	55.5	2.6
4	*5500.00	106.9 PK			2.01 V	284	69.9	37.0
5	*5500.00	96.7 AV			2.01 V	284	59.7	37.0
6	11000.00	57.1 PK	74.0	-16.9	1.36 V	64	40.6	16.5
7	11000.00	43.9 AV	54.0	-10.1	1.36 V	64	27.4	16.5

Remarks:

1. Emission Level(dBuV/m) = Raw Value(dBuV) + Correction Factor(dB/m)
2. Correction Factor(dB/m) = Antenna Factor(dB/m) + Cable Factor(dB) – Pre-Amplifier Factor(dB)
3. Margin value = Emission Level – Limit value
4. The other emission levels were very low against the limit.
5. " * ": Fundamental frequency.
6. " # ": The radiated frequency is out of the restricted band.

RF Mode	TX 802.11ac (VHT20)	Channel	CH 116 : 5580 MHz
Frequency Range	1GHz ~ 40GHz	Detector Function	Peak (PK) Average (AV)

Antenna Polarity & Test Distance : Horizontal at 3 m

No	Frequency (MHz)	Emission Level (dBuV/m)	Limit (dBuV/m)	Margin (dB)	Antenna Height (m)	Table Angle (Degree)	Raw Value (dBuV)	Correction Factor (dB/m)
1	*5580.00	104.2 PK			1.37 H	285	67.2	37.0
2	*5580.00	94.4 AV			1.37 H	285	57.4	37.0
3	11160.00	56.5 PK	74.0	-17.5	1.91 H	100	40.7	15.8
4	11160.00	42.9 AV	54.0	-11.1	1.91 H	100	27.1	15.8

Antenna Polarity & Test Distance : Vertical at 3 m

No	Frequency (MHz)	Emission Level (dBuV/m)	Limit (dBuV/m)	Margin (dB)	Antenna Height (m)	Table Angle (Degree)	Raw Value (dBuV)	Correction Factor (dB/m)
1	*5580.00	107.0 PK			2.12 V	284	70.0	37.0
2	*5580.00	97.5 AV			2.12 V	284	60.5	37.0
3	11160.00	57.0 PK	74.0	-17.0	2.24 V	288	41.2	15.8
4	11160.00	43.1 AV	54.0	-10.9	2.24 V	288	27.3	15.8

Remarks:

1. Emission Level(dBuV/m) = Raw Value(dBuV) + Correction Factor(dB/m)
2. Correction Factor(dB/m) = Antenna Factor(dB/m) + Cable Factor(dB) – Pre-Amplifier Factor(dB)
3. Margin value = Emission Level – Limit value
4. The other emission levels were very low against the limit.
5. " * " : Fundamental frequency.

RF Mode	TX 802.11ac (VHT20)	Channel	CH 140 : 5700 MHz
Frequency Range	1GHz ~ 40GHz	Detector Function	Peak (PK) Average (AV)

Antenna Polarity & Test Distance : Horizontal at 3 m

No	Frequency (MHz)	Emission Level (dBuV/m)	Limit (dBuV/m)	Margin (dB)	Antenna Height (m)	Table Angle (Degree)	Raw Value (dBuV)	Correction Factor (dB/m)
1	*5700.00	105.6 PK			1.41 H	286	68.4	37.2
2	*5700.00	95.4 AV			1.41 H	286	58.2	37.2
3	#5725.00	55.9 PK	68.2	-12.3	1.28 H	264	52.9	3.0
4	11400.00	57.0 PK	74.0	-17.0	1.96 H	113	40.5	16.5
5	11400.00	44.1 AV	54.0	-9.9	1.96 H	113	27.6	16.5

Antenna Polarity & Test Distance : Vertical at 3 m

No	Frequency (MHz)	Emission Level (dBuV/m)	Limit (dBuV/m)	Margin (dB)	Antenna Height (m)	Table Angle (Degree)	Raw Value (dBuV)	Correction Factor (dB/m)
1	*5700.00	108.5 PK			2.11 V	282	71.3	37.2
2	*5700.00	97.8 AV			2.11 V	282	60.6	37.2
3	#5725.00	56.8 PK	68.2	-11.4	2.14 V	299	53.8	3.0
4	11400.00	57.2 PK	74.0	-16.8	1.47 V	67	40.7	16.5
5	11400.00	43.9 AV	54.0	-10.1	1.47 V	67	27.4	16.5

Remarks:

1. Emission Level(dBuV/m) = Raw Value(dBuV) + Correction Factor(dB/m)
2. Correction Factor(dB/m) = Antenna Factor(dB/m) + Cable Factor(dB) – Pre-Amplifier Factor(dB)
3. Margin value = Emission Level – Limit value
4. The other emission levels were very low against the limit.
5. " * " : Fundamental frequency.
6. " # " : The radiated frequency is out of the restricted band.

RF Mode	TX 802.11ac (VHT20)	Channel	CH 144 : 5720 MHz
Frequency Range	1GHz ~ 40GHz	Detector Function	Peak (PK) Average (AV)

Antenna Polarity & Test Distance : Horizontal at 3 m

No	Frequency (MHz)	Emission Level (dBuV/m)	Limit (dBuV/m)	Margin (dB)	Antenna Height (m)	Table Angle (Degree)	Raw Value (dBuV)	Correction Factor (dB/m)
1	*5720.00	105.8 PK			2.21 H	279	68.5	37.3
2	*5720.00	95.1 AV			2.21 H	279	57.8	37.3
3	#5850.00	52.9 PK	68.2	-15.3	2.33 H	255	49.4	3.5
4	11440.00	57.2 PK	74.0	-16.8	1.26 H	75	40.9	16.3
5	11440.00	43.7 AV	54.0	-10.3	1.26 H	75	27.4	16.3

Antenna Polarity & Test Distance : Vertical at 3 m

No	Frequency (MHz)	Emission Level (dBuV/m)	Limit (dBuV/m)	Margin (dB)	Antenna Height (m)	Table Angle (Degree)	Raw Value (dBuV)	Correction Factor (dB/m)
1	*5720.00	107.6 PK			2.33 V	283	70.3	37.3
2	*5720.00	97.3 AV			2.33 V	283	60.0	37.3
3	#5850.00	53.3 PK	68.2	-14.9	2.26 V	291	49.8	3.5
4	11440.00	57.3 PK	74.0	-16.7	1.34 V	60	41.0	16.3
5	11440.00	43.7 AV	54.0	-10.3	1.34 V	60	27.4	16.3

Remarks:

1. Emission Level(dBuV/m) = Raw Value(dBuV) + Correction Factor(dB/m)
2. Correction Factor(dB/m) = Antenna Factor(dB/m) + Cable Factor(dB) – Pre-Amplifier Factor(dB)
3. Margin value = Emission Level – Limit value
4. The other emission levels were very low against the limit.
5. " * " : Fundamental frequency.
6. " # " : The radiated frequency is out of the restricted band.

RF Mode	TX 802.11ac (VHT20)	Channel	CH 149 : 5745 MHz
Frequency Range	1GHz ~ 40GHz	Detector Function	Peak (PK) Average (AV)

Antenna Polarity & Test Distance : Horizontal at 3 m

No	Frequency (MHz)	Emission Level (dBuV/m)	Limit (dBuV/m)	Margin (dB)	Antenna Height (m)	Table Angle (Degree)	Raw Value (dBuV)	Correction Factor (dB/m)
1	#5650.00	50.9 PK	68.2	-17.3	1.08 H	296	48.1	2.8
2	*5745.00	104.0 PK			1.30 H	294	66.7	37.3
3	*5745.00	93.9 AV			1.30 H	294	56.6	37.3
4	#5936.00	52.7 PK	68.2	-15.5	1.08 H	296	49.2	3.5
5	11490.00	54.9 PK	74.0	-19.1	2.01 H	94	38.7	16.2
6	11490.00	43.0 AV	54.0	-11.0	2.01 H	94	26.8	16.2

Antenna Polarity & Test Distance : Vertical at 3 m

No	Frequency (MHz)	Emission Level (dBuV/m)	Limit (dBuV/m)	Margin (dB)	Antenna Height (m)	Table Angle (Degree)	Raw Value (dBuV)	Correction Factor (dB/m)
1	#5610.00	51.4 PK	68.2	-16.8	2.36 V	264	48.6	2.8
2	*5745.00	108.4 PK			2.29 V	277	71.1	37.3
3	*5745.00	98.3 AV			2.29 V	277	61.0	37.3
4	#5953.60	51.8 PK	68.2	-16.4	2.36 V	264	48.3	3.5
5	11490.00	54.8 PK	74.0	-19.2	1.37 V	55	38.6	16.2
6	11490.00	42.5 AV	54.0	-11.5	1.37 V	55	26.3	16.2

Remarks:

1. Emission Level(dBuV/m) = Raw Value(dBuV) + Correction Factor(dB/m)
2. Correction Factor(dB/m) = Antenna Factor(dB/m) + Cable Factor(dB) – Pre-Amplifier Factor(dB)
3. Margin value = Emission Level – Limit value
4. The other emission levels were very low against the limit.
5. " * ": Fundamental frequency.
6. " # ": The radiated frequency is out of the restricted band.

RF Mode	TX 802.11ac (VHT20)	Channel	CH 157 : 5785 MHz
Frequency Range	1GHz ~ 40GHz	Detector Function	Peak (PK) Average (AV)

Antenna Polarity & Test Distance : Horizontal at 3 m

No	Frequency (MHz)	Emission Level (dBuV/m)	Limit (dBuV/m)	Margin (dB)	Antenna Height (m)	Table Angle (Degree)	Raw Value (dBuV)	Correction Factor (dB/m)
1	#5602.80	51.9 PK	68.2	-16.3	1.25 H	283	49.1	2.8
2	*5785.00	103.6 PK			1.53 H	294	66.1	37.5
3	*5785.00	93.8 AV			1.53 H	294	56.3	37.5
4	#5942.00	52.8 PK	68.2	-15.4	1.25 H	283	49.3	3.5
5	11570.00	55.6 PK	74.0	-18.4	1.96 H	98	39.6	16.0
6	11570.00	42.5 AV	54.0	-11.5	1.96 H	98	26.5	16.0

Antenna Polarity & Test Distance : Vertical at 3 m

No	Frequency (MHz)	Emission Level (dBuV/m)	Limit (dBuV/m)	Margin (dB)	Antenna Height (m)	Table Angle (Degree)	Raw Value (dBuV)	Correction Factor (dB/m)
1	#5608.80	51.8 PK	68.2	-16.4	2.45 V	234	49.0	2.8
2	*5785.00	108.7 PK			2.34 V	277	71.2	37.5
3	*5785.00	98.7 AV			2.34 V	277	61.2	37.5
4	#5970.40	53.9 PK	68.2	-14.3	2.45 V	234	50.5	3.4
5	11570.00	55.3 PK	74.0	-18.7	1.42 V	58	39.3	16.0
6	11570.00	42.5 AV	54.0	-11.5	1.42 V	58	26.5	16.0

Remarks:

1. Emission Level(dBuV/m) = Raw Value(dBuV) + Correction Factor(dB/m)
2. Correction Factor(dB/m) = Antenna Factor(dB/m) + Cable Factor(dB) – Pre-Amplifier Factor(dB)
3. Margin value = Emission Level – Limit value
4. The other emission levels were very low against the limit.
5. " * ": Fundamental frequency.
6. " # ": The radiated frequency is out of the restricted band.

RF Mode	TX 802.11ac (VHT20)	Channel	CH 165 : 5825 MHz
Frequency Range	1GHz ~ 40GHz	Detector Function	Peak (PK) Average (AV)

Antenna Polarity & Test Distance : Horizontal at 3 m

No	Frequency (MHz)	Emission Level (dBuV/m)	Limit (dBuV/m)	Margin (dB)	Antenna Height (m)	Table Angle (Degree)	Raw Value (dBuV)	Correction Factor (dB/m)
1	#5647.20	51.7 PK	68.2	-16.5	1.17 H	299	48.9	2.8
2	*5825.00	104.4 PK			1.04 H	297	66.8	37.6
3	*5825.00	93.0 AV			1.04 H	297	55.4	37.6
4	#5935.60	52.7 PK	68.2	-15.5	1.17 H	299	49.2	3.5
5	11650.00	54.2 PK	74.0	-19.8	1.89 H	95	38.2	16.0
6	11650.00	43.0 AV	54.0	-11.0	1.89 H	95	27.0	16.0

Antenna Polarity & Test Distance : Vertical at 3 m

No	Frequency (MHz)	Emission Level (dBuV/m)	Limit (dBuV/m)	Margin (dB)	Antenna Height (m)	Table Angle (Degree)	Raw Value (dBuV)	Correction Factor (dB/m)
1	#5612.00	52.2 PK	68.2	-16.0	2.27 V	251	49.4	2.8
2	*5825.00	108.2 PK			2.35 V	272	70.6	37.6
3	*5825.00	98.1 AV			2.35 V	272	60.5	37.6
4	#5953.20	52.4 PK	68.2	-15.8	2.27 V	251	48.9	3.5
5	11650.00	55.4 PK	74.0	-18.6	1.46 V	67	39.4	16.0
6	11650.00	42.5 AV	54.0	-11.5	1.46 V	67	26.5	16.0

Remarks:

1. Emission Level(dBuV/m) = Raw Value(dBuV) + Correction Factor(dB/m)
2. Correction Factor(dB/m) = Antenna Factor(dB/m) + Cable Factor(dB) – Pre-Amplifier Factor(dB)
3. Margin value = Emission Level – Limit value
4. The other emission levels were very low against the limit.
5. " * " : Fundamental frequency.
6. " # " : The radiated frequency is out of the restricted band.

RF Mode	TX 802.11ac (VHT40)	Channel	CH 38 : 5190 MHz
Frequency Range	1GHz ~ 40GHz	Detector Function	Peak (PK) Average (AV)

Antenna Polarity & Test Distance : Horizontal at 3 m

No	Frequency (MHz)	Emission Level (dBuV/m)	Limit (dBuV/m)	Margin (dB)	Antenna Height (m)	Table Angle (Degree)	Raw Value (dBuV)	Correction Factor (dB/m)
1	5150.00	54.4 PK	74.0	-19.6	1.25 H	204	52.3	2.1
2	5150.00	39.8 AV	54.0	-14.2	1.25 H	204	37.7	2.1
3	*5190.00	102.8 PK			1.37 H	215	66.4	36.4
4	*5190.00	93.1 AV			1.37 H	215	56.7	36.4
5	#10380.00	55.4 PK	68.2	-12.8	2.21 H	96	40.5	14.9

Antenna Polarity & Test Distance : Vertical at 3 m

No	Frequency (MHz)	Emission Level (dBuV/m)	Limit (dBuV/m)	Margin (dB)	Antenna Height (m)	Table Angle (Degree)	Raw Value (dBuV)	Correction Factor (dB/m)
1	5150.00	55.5 PK	74.0	-18.5	1.95 V	196	53.4	2.1
2	5150.00	40.1 AV	54.0	-13.9	1.95 V	196	38.0	2.1
3	*5190.00	103.4 PK			1.88 V	200	67.0	36.4
4	*5190.00	94.6 AV			1.88 V	200	58.2	36.4
5	#10380.00	55.6 PK	68.2	-12.6	1.41 V	64	40.7	14.9

Remarks:

1. Emission Level(dBuV/m) = Raw Value(dBuV) + Correction Factor(dB/m)
2. Correction Factor(dB/m) = Antenna Factor(dB/m) + Cable Factor(dB) – Pre-Amplifier Factor(dB)
3. Margin value = Emission Level – Limit value
4. The other emission levels were very low against the limit.
5. " * " : Fundamental frequency.
6. " # " : The radiated frequency is out of the restricted band.

RF Mode	TX 802.11ac (VHT40)	Channel	CH 46 : 5230 MHz
Frequency Range	1GHz ~ 40GHz	Detector Function	Peak (PK) Average (AV)

Antenna Polarity & Test Distance : Horizontal at 3 m

No	Frequency (MHz)	Emission Level (dBuV/m)	Limit (dBuV/m)	Margin (dB)	Antenna Height (m)	Table Angle (Degree)	Raw Value (dBuV)	Correction Factor (dB/m)
1	*5230.00	102.1 PK			1.36 H	207	65.8	36.3
2	*5230.00	92.5 AV			1.36 H	207	56.2	36.3
3	5350.00	51.7 PK	74.0	-22.3	1.33 H	195	49.7	2.0
4	5350.00	38.8 AV	54.0	-15.2	1.33 H	195	36.8	2.0
5	#10460.00	55.7 PK	68.2	-12.5	2.03 H	100	40.8	14.9

Antenna Polarity & Test Distance : Vertical at 3 m

No	Frequency (MHz)	Emission Level (dBuV/m)	Limit (dBuV/m)	Margin (dB)	Antenna Height (m)	Table Angle (Degree)	Raw Value (dBuV)	Correction Factor (dB/m)
1	*5230.00	104.2 PK			2.42 V	208	67.9	36.3
2	*5230.00	94.6 AV			2.42 V	208	58.3	36.3
3	5350.00	51.8 PK	74.0	-22.2	2.35 V	199	49.8	2.0
4	5350.00	39.0 AV	54.0	-15.0	2.35 V	199	37.0	2.0
5	#10460.00	56.1 PK	68.2	-12.1	1.44 V	58	41.2	14.9

Remarks:

1. Emission Level(dBuV/m) = Raw Value(dBuV) + Correction Factor(dB/m)
2. Correction Factor(dB/m) = Antenna Factor(dB/m) + Cable Factor(dB) – Pre-Amplifier Factor(dB)
3. Margin value = Emission Level – Limit value
4. The other emission levels were very low against the limit.
5. " * " : Fundamental frequency.
6. " # " : The radiated frequency is out of the restricted band.

RF Mode	TX 802.11ac (VHT40)	Channel	CH 54 : 5270 MHz
Frequency Range	1GHz ~ 40GHz	Detector Function	Peak (PK) Average (AV)

Antenna Polarity & Test Distance : Horizontal at 3 m

No	Frequency (MHz)	Emission Level (dBuV/m)	Limit (dBuV/m)	Margin (dB)	Antenna Height (m)	Table Angle (Degree)	Raw Value (dBuV)	Correction Factor (dB/m)
1	5150.00	52.6 PK	74.0	-21.4	1.38 H	202	50.5	2.1
2	5150.00	39.1 AV	54.0	-14.9	1.38 H	202	37.0	2.1
3	*5270.00	102.7 PK			1.48 H	209	66.5	36.2
4	*5270.00	92.0 AV			1.48 H	209	55.8	36.2
5	#10540.00	55.6 PK	68.2	-12.6	1.91 H	89	40.4	15.2

Antenna Polarity & Test Distance : Vertical at 3 m

No	Frequency (MHz)	Emission Level (dBuV/m)	Limit (dBuV/m)	Margin (dB)	Antenna Height (m)	Table Angle (Degree)	Raw Value (dBuV)	Correction Factor (dB/m)
1	5150.00	52.5 PK	74.0	-21.5	2.38 V	200	50.4	2.1
2	5150.00	38.9 AV	54.0	-15.1	2.38 V	200	36.8	2.1
3	*5270.00	103.7 PK			2.49 V	204	67.5	36.2
4	*5270.00	93.8 AV			2.49 V	204	57.6	36.2
5	#10540.00	55.7 PK	68.2	-12.5	1.40 V	68	40.5	15.2

Remarks:

1. Emission Level(dBuV/m) = Raw Value(dBuV) + Correction Factor(dB/m)
2. Correction Factor(dB/m) = Antenna Factor(dB/m) + Cable Factor(dB) – Pre-Amplifier Factor(dB)
3. Margin value = Emission Level – Limit value
4. The other emission levels were very low against the limit.
5. " * " : Fundamental frequency.
6. " # " : The radiated frequency is out of the restricted band.

RF Mode	TX 802.11ac (VHT40)	Channel	CH 62 : 5310 MHz
Frequency Range	1GHz ~ 40GHz	Detector Function	Peak (PK) Average (AV)

Antenna Polarity & Test Distance : Horizontal at 3 m

No	Frequency (MHz)	Emission Level (dBuV/m)	Limit (dBuV/m)	Margin (dB)	Antenna Height (m)	Table Angle (Degree)	Raw Value (dBuV)	Correction Factor (dB/m)
1	*5310.00	100.3 PK			1.37 H	205	64.2	36.1
2	*5310.00	90.7 AV			1.37 H	205	54.6	36.1
3	5350.00	55.4 PK	74.0	-18.6	1.33 H	196	53.4	2.0
4	5350.00	39.8 AV	54.0	-14.2	1.33 H	196	37.8	2.0
5	10620.00	56.1 PK	74.0	-17.9	1.92 H	90	40.5	15.6
6	10620.00	42.6 AV	54.0	-11.4	1.92 H	90	27.0	15.6

Antenna Polarity & Test Distance : Vertical at 3 m

No	Frequency (MHz)	Emission Level (dBuV/m)	Limit (dBuV/m)	Margin (dB)	Antenna Height (m)	Table Angle (Degree)	Raw Value (dBuV)	Correction Factor (dB/m)
1	*5310.00	102.2 PK			2.08 V	205	66.1	36.1
2	*5310.00	92.8 AV			2.08 V	205	56.7	36.1
3	5350.00	55.5 PK	74.0	-18.5	1.97 V	202	53.5	2.0
4	5350.00	40.0 AV	54.0	-14.0	1.97 V	202	38.0	2.0
5	10620.00	56.3 PK	74.0	-17.7	1.40 V	67	40.7	15.6
6	10620.00	42.8 AV	54.0	-11.2	1.40 V	67	27.2	15.6

Remarks:

1. Emission Level(dBuV/m) = Raw Value(dBuV) + Correction Factor(dB/m)
2. Correction Factor(dB/m) = Antenna Factor(dB/m) + Cable Factor(dB) – Pre-Amplifier Factor(dB)
3. Margin value = Emission Level – Limit value
4. The other emission levels were very low against the limit.
5. " * ": Fundamental frequency.

RF Mode	TX 802.11ac (VHT40)	Channel	CH 102 : 5510 MHz
Frequency Range	1GHz ~ 40GHz	Detector Function	Peak (PK) Average (AV)

Antenna Polarity & Test Distance : Horizontal at 3 m

No	Frequency (MHz)	Emission Level (dBuV/m)	Limit (dBuV/m)	Margin (dB)	Antenna Height (m)	Table Angle (Degree)	Raw Value (dBuV)	Correction Factor (dB/m)
1	5460.00	55.3 PK	74.0	-18.7	1.24 H	303	52.7	2.6
2	5460.00	40.5 AV	54.0	-13.5	1.24 H	303	37.9	2.6
3	#5470.00	55.7 PK	68.2	-12.5	1.24 H	303	53.1	2.6
4	*5510.00	101.2 PK			1.33 H	284	64.2	37.0
5	*5510.00	91.2 AV			1.33 H	284	54.2	37.0
6	11020.00	57.0 PK	74.0	-17.0	1.98 H	90	40.6	16.4
7	11020.00	43.5 AV	54.0	-10.5	1.98 H	90	27.1	16.4

Antenna Polarity & Test Distance : Vertical at 3 m

No	Frequency (MHz)	Emission Level (dBuV/m)	Limit (dBuV/m)	Margin (dB)	Antenna Height (m)	Table Angle (Degree)	Raw Value (dBuV)	Correction Factor (dB/m)
1	5460.00	57.4 PK	74.0	-16.6	2.36 V	291	54.8	2.6
2	5460.00	41.8 AV	54.0	-12.2	2.36 V	291	39.2	2.6
3	#5470.00	58.1 PK	68.2	-10.1	2.36 V	291	55.5	2.6
4	*5510.00	103.7 PK			2.30 V	277	66.7	37.0
5	*5510.00	94.0 AV			2.30 V	277	57.0	37.0
6	11020.00	56.9 PK	74.0	-17.1	1.37 V	59	40.5	16.4
7	11020.00	43.4 AV	54.0	-10.6	1.37 V	59	27.0	16.4

Remarks:

1. Emission Level(dBuV/m) = Raw Value(dBuV) + Correction Factor(dB/m)
2. Correction Factor(dB/m) = Antenna Factor(dB/m) + Cable Factor(dB) – Pre-Amplifier Factor(dB)
3. Margin value = Emission Level – Limit value
4. The other emission levels were very low against the limit.
5. " * ": Fundamental frequency.
6. " # ": The radiated frequency is out of the restricted band.

RF Mode	TX 802.11ac (VHT40)	Channel	CH 110 : 5550 MHz
Frequency Range	1GHz ~ 40GHz	Detector Function	Peak (PK) Average (AV)

Antenna Polarity & Test Distance : Horizontal at 3 m

No	Frequency (MHz)	Emission Level (dBuV/m)	Limit (dBuV/m)	Margin (dB)	Antenna Height (m)	Table Angle (Degree)	Raw Value (dBuV)	Correction Factor (dB/m)
1	*5550.00	101.3 PK			1.48 H	287	64.3	37.0
2	*5550.00	90.6 AV			1.48 H	287	53.6	37.0
3	11100.00	56.4 PK	74.0	-17.6	1.94 H	105	40.7	15.7
4	11100.00	42.9 AV	54.0	-11.1	1.94 H	105	27.2	15.7

Antenna Polarity & Test Distance : Vertical at 3 m

No	Frequency (MHz)	Emission Level (dBuV/m)	Limit (dBuV/m)	Margin (dB)	Antenna Height (m)	Table Angle (Degree)	Raw Value (dBuV)	Correction Factor (dB/m)
1	*5550.00	103.7 PK			2.30 V	275	66.7	37.0
2	*5550.00	93.7 AV			2.30 V	275	56.7	37.0
3	11100.00	56.2 PK	74.0	-17.8	1.23 V	69	40.5	15.7
4	11100.00	42.5 AV	54.0	-11.5	1.23 V	69	26.8	15.7

Remarks:

1. Emission Level(dBuV/m) = Raw Value(dBuV) + Correction Factor(dB/m)
2. Correction Factor(dB/m) = Antenna Factor(dB/m) + Cable Factor(dB) – Pre-Amplifier Factor(dB)
3. Margin value = Emission Level – Limit value
4. The other emission levels were very low against the limit.
5. " * " : Fundamental frequency.

RF Mode	TX 802.11ac (VHT40)	Channel	CH 134 : 5670 MHz
Frequency Range	1GHz ~ 40GHz	Detector Function	Peak (PK) Average (AV)

Antenna Polarity & Test Distance : Horizontal at 3 m

No	Frequency (MHz)	Emission Level (dBuV/m)	Limit (dBuV/m)	Margin (dB)	Antenna Height (m)	Table Angle (Degree)	Raw Value (dBuV)	Correction Factor (dB/m)
1	*5670.00	101.8 PK			1.42 H	298	64.7	37.1
2	*5670.00	92.2 AV			1.42 H	298	55.1	37.1
3	#5725.00	55.1 PK	68.2	-13.1	1.36 H	284	52.1	3.0
4	11340.00	57.0 PK	74.0	-17.0	1.93 H	105	40.6	16.4
5	11340.00	43.1 AV	54.0	-10.9	1.93 H	105	26.7	16.4

Antenna Polarity & Test Distance : Vertical at 3 m

No	Frequency (MHz)	Emission Level (dBuV/m)	Limit (dBuV/m)	Margin (dB)	Antenna Height (m)	Table Angle (Degree)	Raw Value (dBuV)	Correction Factor (dB/m)
1	*5670.00	104.4 PK			2.32 V	276	67.3	37.1
2	*5670.00	94.6 AV			2.32 V	276	57.5	37.1
3	#5725.00	57.9 PK	68.2	-10.3	2.49 V	293	54.9	3.0
4	11340.00	58.0 PK	74.0	-16.0	1.41 V	65	41.6	16.4
5	11340.00	43.8 AV	54.0	-10.2	1.41 V	65	27.4	16.4

Remarks:

1. Emission Level(dBuV/m) = Raw Value(dBuV) + Correction Factor(dB/m)
2. Correction Factor(dB/m) = Antenna Factor(dB/m) + Cable Factor(dB) – Pre-Amplifier Factor(dB)
3. Margin value = Emission Level – Limit value
4. The other emission levels were very low against the limit.
5. " * ": Fundamental frequency.
6. " # ": The radiated frequency is out of the restricted band.

RF Mode	TX 802.11ac (VHT40)	Channel	CH 142 : 5710 MHz
Frequency Range	1GHz ~ 40GHz	Detector Function	Peak (PK) Average (AV)

Antenna Polarity & Test Distance : Horizontal at 3 m

No	Frequency (MHz)	Emission Level (dBuV/m)	Limit (dBuV/m)	Margin (dB)	Antenna Height (m)	Table Angle (Degree)	Raw Value (dBuV)	Correction Factor (dB/m)
1	*5710.00	101.4 PK			1.36 H	277	64.2	37.2
2	*5710.00	91.9 AV			1.36 H	277	54.7	37.2
3	#5850.00	53.0 PK	68.2	-15.2	1.26 H	281	49.5	3.5
4	11420.00	57.2 PK	74.0	-16.8	1.93 H	109	40.8	16.4
5	11420.00	43.6 AV	54.0	-10.4	1.93 H	109	27.2	16.4

Antenna Polarity & Test Distance : Vertical at 3 m

No	Frequency (MHz)	Emission Level (dBuV/m)	Limit (dBuV/m)	Margin (dB)	Antenna Height (m)	Table Angle (Degree)	Raw Value (dBuV)	Correction Factor (dB/m)
1	*5710.00	103.9 PK			2.32 V	275	66.7	37.2
2	*5710.00	94.2 AV			2.32 V	275	57.0	37.2
3	#5850.00	53.2 PK	68.2	-15.0	2.14 V	277	49.7	3.5
4	11420.00	56.9 PK	74.0	-17.1	1.41 V	62	40.5	16.4
5	11420.00	43.2 AV	54.0	-10.8	1.41 V	62	26.8	16.4

Remarks:

1. Emission Level(dBuV/m) = Raw Value(dBuV) + Correction Factor(dB/m)
2. Correction Factor(dB/m) = Antenna Factor(dB/m) + Cable Factor(dB) – Pre-Amplifier Factor(dB)
3. Margin value = Emission Level – Limit value
4. The other emission levels were very low against the limit.
5. " * " : Fundamental frequency.
6. " # " : The radiated frequency is out of the restricted band.

RF Mode	TX 802.11ac (VHT40)	Channel	CH 151 : 5755 MHz
Frequency Range	1GHz ~ 40GHz	Detector Function	Peak (PK) Average (AV)

Antenna Polarity & Test Distance : Horizontal at 3 m

No	Frequency (MHz)	Emission Level (dBuV/m)	Limit (dBuV/m)	Margin (dB)	Antenna Height (m)	Table Angle (Degree)	Raw Value (dBuV)	Correction Factor (dB/m)
1	#5606.80	50.9 PK	68.2	-17.3	1.14 H	291	48.1	2.8
2	*5755.00	100.5 PK			1.00 H	296	63.2	37.3
3	*5755.00	90.1 AV			1.00 H	296	52.8	37.3
4	#5990.80	52.5 PK	68.2	-15.7	1.14 H	291	49.1	3.4
5	11510.00	56.2 PK	74.0	-17.8	1.93 H	94	40.1	16.1
6	11510.00	42.9 AV	54.0	-11.1	1.93 H	94	26.8	16.1

Antenna Polarity & Test Distance : Vertical at 3 m

No	Frequency (MHz)	Emission Level (dBuV/m)	Limit (dBuV/m)	Margin (dB)	Antenna Height (m)	Table Angle (Degree)	Raw Value (dBuV)	Correction Factor (dB/m)
1	#5601.60	51.4 PK	68.2	-16.8	2.37 V	262	48.6	2.8
2	*5755.00	103.2 PK			2.40 V	269	65.9	37.3
3	*5755.00	94.0 AV			2.40 V	269	56.7	37.3
4	#5985.60	52.6 PK	68.2	-15.6	2.37 V	262	49.2	3.4
5	11510.00	55.9 PK	74.0	-18.1	1.47 V	62	39.8	16.1
6	11510.00	42.5 AV	54.0	-11.5	1.47 V	62	26.4	16.1

Remarks:

1. Emission Level(dBuV/m) = Raw Value(dBuV) + Correction Factor(dB/m)
2. Correction Factor(dB/m) = Antenna Factor(dB/m) + Cable Factor(dB) – Pre-Amplifier Factor(dB)
3. Margin value = Emission Level – Limit value
4. The other emission levels were very low against the limit.
5. " * " : Fundamental frequency.
6. " # " : The radiated frequency is out of the restricted band.

RF Mode	TX 802.11ac (VHT40)	Channel	CH 159 : 5795 MHz
Frequency Range	1GHz ~ 40GHz	Detector Function	Peak (PK) Average (AV)

Antenna Polarity & Test Distance : Horizontal at 3 m

No	Frequency (MHz)	Emission Level (dBuV/m)	Limit (dBuV/m)	Margin (dB)	Antenna Height (m)	Table Angle (Degree)	Raw Value (dBuV)	Correction Factor (dB/m)
1	#5620.80	51.4 PK	68.2	-16.8	1.05 H	286	48.7	2.7
2	*5795.00	100.2 PK			1.02 H	295	62.6	37.6
3	*5795.00	90.8 AV			1.02 H	295	53.2	37.6
4	#5951.20	52.6 PK	68.2	-15.6	1.05 H	286	49.1	3.5
5	11590.00	54.7 PK	74.0	-19.3	1.98 H	104	38.7	16.0
6	11590.00	42.4 AV	54.0	-11.6	1.98 H	104	26.4	16.0

Antenna Polarity & Test Distance : Vertical at 3 m

No	Frequency (MHz)	Emission Level (dBuV/m)	Limit (dBuV/m)	Margin (dB)	Antenna Height (m)	Table Angle (Degree)	Raw Value (dBuV)	Correction Factor (dB/m)
1	#5616.00	51.1 PK	68.2	-17.1	2.34 V	290	48.4	2.7
2	*5795.00	105.6 PK			2.30 V	274	68.0	37.6
3	*5795.00	95.2 AV			2.30 V	274	57.6	37.6
4	#5993.60	53.2 PK	68.2	-15.0	2.34 V	290	49.8	3.4
5	11590.00	56.2 PK	74.0	-17.8	1.39 V	60	40.2	16.0
6	11590.00	42.6 AV	54.0	-11.4	1.39 V	60	26.6	16.0

Remarks:

1. Emission Level(dBuV/m) = Raw Value(dBuV) + Correction Factor(dB/m)
2. Correction Factor(dB/m) = Antenna Factor(dB/m) + Cable Factor(dB) – Pre-Amplifier Factor(dB)
3. Margin value = Emission Level – Limit value
4. The other emission levels were very low against the limit.
5. " * " : Fundamental frequency.
6. " # " : The radiated frequency is out of the restricted band.

RF Mode	TX 802.11ac (VHT80)	Channel	CH 42 : 5210 MHz
Frequency Range	1GHz ~ 40GHz	Detector Function	Peak (PK) Average (AV)

Antenna Polarity & Test Distance : Horizontal at 3 m

No	Frequency (MHz)	Emission Level (dBuV/m)	Limit (dBuV/m)	Margin (dB)	Antenna Height (m)	Table Angle (Degree)	Raw Value (dBuV)	Correction Factor (dB/m)
1	5150.00	51.7 PK	74.0	-22.3	1.46 H	201	49.6	2.1
2	5150.00	39.1 AV	54.0	-14.9	1.46 H	201	37.0	2.1
3	*5210.00	98.5 PK			1.35 H	204	62.1	36.4
4	*5210.00	89.4 AV			1.35 H	204	53.0	36.4
5	5350.00	52.1 PK	74.0	-21.9	1.46 H	201	50.1	2.0
6	5350.00	39.3 AV	54.0	-14.7	1.46 H	201	37.3	2.0
7	#10420.00	55.4 PK	68.2	-12.8	1.93 H	99	40.5	14.9

Antenna Polarity & Test Distance : Vertical at 3 m

No	Frequency (MHz)	Emission Level (dBuV/m)	Limit (dBuV/m)	Margin (dB)	Antenna Height (m)	Table Angle (Degree)	Raw Value (dBuV)	Correction Factor (dB/m)
1	5150.00	51.8 PK	74.0	-22.2	2.01 V	204	49.7	2.1
2	5150.00	39.1 AV	54.0	-14.9	2.01 V	204	37.0	2.1
3	*5210.00	100.6 PK			2.00 V	198	64.2	36.4
4	*5210.00	91.7 AV			2.00 V	198	55.3	36.4
5	5350.00	52.2 PK	74.0	-21.8	2.01 V	204	50.2	2.0
6	5350.00	39.4 AV	54.0	-14.6	2.01 V	204	37.4	2.0
7	#10420.00	55.1 PK	68.2	-13.1	1.38 V	57	40.2	14.9

Remarks:

1. Emission Level(dBuV/m) = Raw Value(dBuV) + Correction Factor(dB/m)
2. Correction Factor(dB/m) = Antenna Factor(dB/m) + Cable Factor(dB) – Pre-Amplifier Factor(dB)
3. Margin value = Emission Level – Limit value
4. The other emission levels were very low against the limit.
5. " * ": Fundamental frequency.
6. " # ": The radiated frequency is out of the restricted band.

RF Mode	TX 802.11ac (VHT80)	Channel	CH 58 : 5290 MHz
Frequency Range	1GHz ~ 40GHz	Detector Function	Peak (PK) Average (AV)

Antenna Polarity & Test Distance : Horizontal at 3 m

No	Frequency (MHz)	Emission Level (dBuV/m)	Limit (dBuV/m)	Margin (dB)	Antenna Height (m)	Table Angle (Degree)	Raw Value (dBuV)	Correction Factor (dB/m)
1	*5290.00	98.9 PK			1.31 H	206	62.8	36.1
2	*5290.00	89.3 AV			1.31 H	206	53.2	36.1
3	5350.00	58.1 PK	74.0	-15.9	1.36 H	228	56.1	2.0
4	5350.00	45.4 AV	54.0	-8.6	1.36 H	228	43.4	2.0
5	#10580.00	55.9 PK	68.2	-12.3	1.98 H	92	40.5	15.4

Antenna Polarity & Test Distance : Vertical at 3 m

No	Frequency (MHz)	Emission Level (dBuV/m)	Limit (dBuV/m)	Margin (dB)	Antenna Height (m)	Table Angle (Degree)	Raw Value (dBuV)	Correction Factor (dB/m)
1	*5290.00	100.2 PK			1.99 V	205	64.1	36.1
2	*5290.00	90.5 AV			1.99 V	205	54.4	36.1
3	5350.00	59.5 PK	74.0	-14.5	2.18 V	281	57.5	2.0
4	5350.00	47.5 AV	54.0	-6.5	2.18 V	281	45.5	2.0
5	#10580.00	56.2 PK	68.2	-12.0	1.99 V	93	40.8	15.4

Remarks:

1. Emission Level(dBuV/m) = Raw Value(dBuV) + Correction Factor(dB/m)
2. Correction Factor(dB/m) = Antenna Factor(dB/m) + Cable Factor(dB) – Pre-Amplifier Factor(dB)
3. Margin value = Emission Level – Limit value
4. The other emission levels were very low against the limit.
5. " * " : Fundamental frequency.
6. " # " : The radiated frequency is out of the restricted band.

RF Mode	TX 802.11ac (VHT80)	Channel	CH 106 : 5530 MHz
Frequency Range	1GHz ~ 40GHz	Detector Function	Peak (PK) Average (AV)

Antenna Polarity & Test Distance : Horizontal at 3 m

No	Frequency (MHz)	Emission Level (dBuV/m)	Limit (dBuV/m)	Margin (dB)	Antenna Height (m)	Table Angle (Degree)	Raw Value (dBuV)	Correction Factor (dB/m)
1	5460.00	53.1 PK	74.0	-20.9	1.39 H	281	50.5	2.6
2	5460.00	41.3 AV	54.0	-12.7	1.39 H	281	38.7	2.6
3	#5470.00	55.1 PK	68.2	-13.1	1.39 H	281	52.5	2.6
4	*5530.00	100.2 PK			1.31 H	274	63.2	37.0
5	*5530.00	90.0 AV			1.31 H	274	53.0	37.0
6	#5725.00	53.8 PK	68.2	-14.4	1.39 H	281	50.8	3.0
7	11060.00	56.5 PK	74.0	-17.5	1.92 H	100	40.4	16.1
8	11060.00	43.5 AV	54.0	-10.5	1.92 H	100	27.4	16.1

Antenna Polarity & Test Distance : Vertical at 3 m

No	Frequency (MHz)	Emission Level (dBuV/m)	Limit (dBuV/m)	Margin (dB)	Antenna Height (m)	Table Angle (Degree)	Raw Value (dBuV)	Correction Factor (dB/m)
1	5460.00	53.6 PK	74.0	-20.4	2.23 V	261	51.0	2.6
2	5460.00	41.9 AV	54.0	-12.1	2.23 V	261	39.3	2.6
3	#5470.00	56.6 PK	68.2	-11.6	2.23 V	261	54.0	2.6
4	*5530.00	100.8 PK			2.31 V	277	63.8	37.0
5	*5530.00	91.5 AV			2.31 V	277	54.5	37.0
6	#5725.00	54.3 PK	68.2	-13.9	2.23 V	261	51.3	3.0
7	11060.00	56.8 PK	74.0	-17.2	1.45 V	63	40.7	16.1
8	11060.00	43.4 AV	54.0	-10.6	1.45 V	63	27.3	16.1

Remarks:

1. Emission Level(dBuV/m) = Raw Value(dBuV) + Correction Factor(dB/m)
2. Correction Factor(dB/m) = Antenna Factor(dB/m) + Cable Factor(dB) – Pre-Amplifier Factor(dB)
3. Margin value = Emission Level – Limit value
4. The other emission levels were very low against the limit.
5. " * ": Fundamental frequency.
6. " # ": The radiated frequency is out of the restricted band.

RF Mode	TX 802.11ac (VHT80)	Channel	CH 122 : 5610 MHz
Frequency Range	1GHz ~ 40GHz	Detector Function	Peak (PK) Average (AV)

Antenna Polarity & Test Distance : Horizontal at 3 m

No	Frequency (MHz)	Emission Level (dBuV/m)	Limit (dBuV/m)	Margin (dB)	Antenna Height (m)	Table Angle (Degree)	Raw Value (dBuV)	Correction Factor (dB/m)
1	5460.00	52.3 PK	74.0	-21.7	1.44 H	288	49.7	2.6
2	5460.00	40.0 AV	54.0	-14.0	1.44 H	288	37.4	2.6
3	#5470.00	53.1 PK	68.2	-15.1	1.44 H	288	50.5	2.6
4	*5610.00	98.5 PK			1.42 H	283	61.5	37.0
5	*5610.00	89.3 AV			1.42 H	283	52.3	37.0
6	#5725.00	52.5 PK	68.2	-15.7	1.44 H	288	49.5	3.0
7	11220.00	56.3 PK	74.0	-17.7	1.92 H	104	40.6	15.7
8	11220.00	43.1 AV	54.0	-10.9	1.92 H	104	27.4	15.7

Antenna Polarity & Test Distance : Vertical at 3 m

No	Frequency (MHz)	Emission Level (dBuV/m)	Limit (dBuV/m)	Margin (dB)	Antenna Height (m)	Table Angle (Degree)	Raw Value (dBuV)	Correction Factor (dB/m)
1	5460.00	52.6 PK	74.0	-21.4	2.26 V	289	50.0	2.6
2	5460.00	40.1 AV	54.0	-13.9	2.26 V	289	37.5	2.6
3	#5470.00	52.9 PK	68.2	-15.3	2.26 V	289	50.3	2.6
4	*5610.00	101.0 PK			2.34 V	276	64.0	37.0
5	*5610.00	91.3 AV			2.34 V	276	54.3	37.0
6	#5725.00	52.8 PK	68.2	-15.4	2.26 V	289	49.8	3.0
7	11220.00	56.2 PK	74.0	-17.8	1.29 V	64	40.5	15.7
8	11220.00	42.9 AV	54.0	-11.1	1.29 V	64	27.2	15.7

Remarks:

1. Emission Level(dBuV/m) = Raw Value(dBuV) + Correction Factor(dB/m)
2. Correction Factor(dB/m) = Antenna Factor(dB/m) + Cable Factor(dB) – Pre-Amplifier Factor(dB)
3. Margin value = Emission Level – Limit value
4. The other emission levels were very low against the limit.
5. " * ": Fundamental frequency.
6. " # ": The radiated frequency is out of the restricted band.

RF Mode	TX 802.11ac (VHT80)	Channel	CH 138 : 5690 MHz
Frequency Range	1GHz ~ 40GHz	Detector Function	Peak (PK) Average (AV)

Antenna Polarity & Test Distance : Horizontal at 3 m

No	Frequency (MHz)	Emission Level (dBuV/m)	Limit (dBuV/m)	Margin (dB)	Antenna Height (m)	Table Angle (Degree)	Raw Value (dBuV)	Correction Factor (dB/m)
1	*5690.00	100.0 PK			1.40 H	281	62.8	37.2
2	*5690.00	91.0 AV			1.40 H	281	53.8	37.2
3	#5850.00	52.9 PK	68.2	-15.3	1.21 H	279	49.4	3.5
4	11380.00	57.7 PK	74.0	-16.3	1.95 H	95	41.2	16.5
5	11380.00	43.8 AV	54.0	-10.2	1.95 H	95	27.3	16.5

Antenna Polarity & Test Distance : Vertical at 3 m

No	Frequency (MHz)	Emission Level (dBuV/m)	Limit (dBuV/m)	Margin (dB)	Antenna Height (m)	Table Angle (Degree)	Raw Value (dBuV)	Correction Factor (dB/m)
1	*5690.00	101.7 PK			2.33 V	276	64.5	37.2
2	*5690.00	92.3 AV			2.33 V	276	55.1	37.2
3	#5850.00	53.0 PK	68.2	-15.2	2.47 V	297	49.5	3.5
4	11380.00	57.2 PK	74.0	-16.8	1.29 V	74	40.7	16.5
5	11380.00	43.7 AV	54.0	-10.3	1.29 V	74	27.2	16.5

Remarks:

1. Emission Level(dBuV/m) = Raw Value(dBuV) + Correction Factor(dB/m)
2. Correction Factor(dB/m) = Antenna Factor(dB/m) + Cable Factor(dB) – Pre-Amplifier Factor(dB)
3. Margin value = Emission Level – Limit value
4. The other emission levels were very low against the limit.
5. " * " : Fundamental frequency.
6. " # " : The radiated frequency is out of the restricted band.

RF Mode	TX 802.11ac (VHT80)	Channel	CH 155 : 5775 MHz
Frequency Range	1GHz ~ 40GHz	Detector Function	Peak (PK) Average (AV)

Antenna Polarity & Test Distance : Horizontal at 3 m

No	Frequency (MHz)	Emission Level (dBuV/m)	Limit (dBuV/m)	Margin (dB)	Antenna Height (m)	Table Angle (Degree)	Raw Value (dBuV)	Correction Factor (dB/m)
1	#5636.80	50.5 PK	68.2	-17.7	1.13 H	284	47.8	2.7
2	*5775.00	97.9 PK			1.00 H	296	60.4	37.5
3	*5775.00	88.8 AV			1.00 H	296	51.3	37.5
4	#5943.20	52.6 PK	68.2	-15.6	1.13 H	284	49.1	3.5
5	11550.00	53.7 PK	74.0	-20.3	1.94 H	99	37.6	16.1
6	11550.00	42.2 AV	54.0	-11.8	1.94 H	99	26.1	16.1

Antenna Polarity & Test Distance : Vertical at 3 m

No	Frequency (MHz)	Emission Level (dBuV/m)	Limit (dBuV/m)	Margin (dB)	Antenna Height (m)	Table Angle (Degree)	Raw Value (dBuV)	Correction Factor (dB/m)
1	#5630.00	52.1 PK	68.2	-16.1	2.20 V	258	49.4	2.7
2	*5775.00	102.9 PK			2.35 V	275	65.4	37.5
3	*5775.00	92.2 AV			2.35 V	275	54.7	37.5
4	#5938.80	52.9 PK	68.2	-15.3	2.20 V	258	49.4	3.5
5	11550.00	55.0 PK	74.0	-19.0	1.35 V	56	38.9	16.1
6	11550.00	42.7 AV	54.0	-11.3	1.35 V	56	26.6	16.1

Remarks:

1. Emission Level(dBuV/m) = Raw Value(dBuV) + Correction Factor(dB/m)
2. Correction Factor(dB/m) = Antenna Factor(dB/m) + Cable Factor(dB) – Pre-Amplifier Factor(dB)
3. Margin value = Emission Level – Limit value
4. The other emission levels were very low against the limit.
5. " * " : Fundamental frequency.
6. " # " : The radiated frequency is out of the restricted band.

Below 1GHz Worst-Case Data:

RF Mode	TX 802.11a	Channel	CH 36 : 5180 MHz
Frequency Range	30MHz ~ 1GHz	Detector Function	Quasi-Peak (QP)
Test Mode	A		

Antenna Polarity & Test Distance : Horizontal at 3 m								
No	Frequency (MHz)	Emission Level (dBuV/m)	Limit (dBuV/m)	Margin (dB)	Antenna Height (m)	Table Angle (Degree)	Raw Value (dBuV)	Correction Factor (dB/m)
1	56.19	35.1 QP	40.0	-4.9	1.00 H	169	44.1	-9.0
2	102.75	25.4 QP	43.5	-18.1	1.25 H	28	38.0	-12.6
3	145.43	23.1 QP	43.5	-20.4	1.50 H	235	31.6	-8.5
4	290.93	22.7 QP	46.0	-23.3	1.00 H	209	29.8	-7.1
5	473.29	25.0 QP	46.0	-21.0	2.00 H	232	28.0	-3.0
6	907.85	33.6 QP	46.0	-12.4	1.00 H	206	28.3	5.3

Remarks:

1. Emission Level(dBuV/m) = Raw Value(dBuV) + Correction Factor(dB/m)
2. Correction Factor(dB/m) = Antenna Factor(dB/m) + Cable Factor(dB) – Pre-Amplifier Factor(dB)
3. Margin value = Emission Level – Limit value
4. The other emission levels were very low against the limit of frequency range 30MHz~1000MHz.
5. The emission levels were very low against the limit of frequency range 9kHz~30MHz: the amplitude of spurious emissions attenuated more than 20 dB below the permissible value to be report.

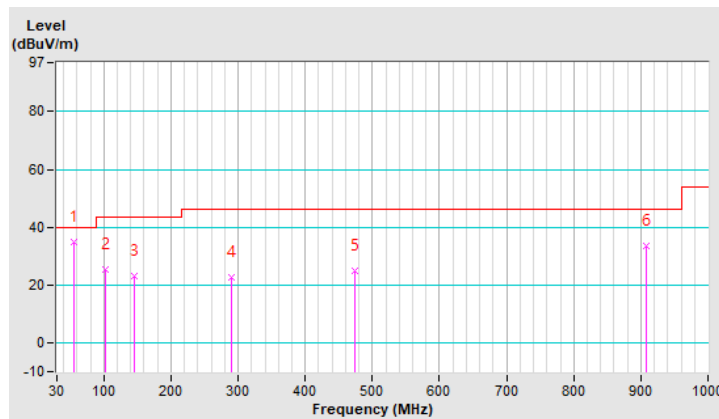

RF Mode	TX 802.11a	Channel	CH 36 : 5180 MHz
Frequency Range	30MHz ~ 1GHz	Detector Function	Quasi-Peak (QP)
Test Mode	A		

Antenna Polarity & Test Distance : Vertical at 3 m								
No	Frequency (MHz)	Emission Level (dBuV/m)	Limit (dBuV/m)	Margin (dB)	Antenna Height (m)	Table Angle (Degree)	Raw Value (dBuV)	Correction Factor (dB/m)
1	69.77	25.7 QP	40.0	-14.3	1.25 V	124	36.5	-10.8
2	104.69	22.8 QP	43.5	-20.7	1.25 V	107	35.0	-12.2
3	275.41	19.7 QP	46.0	-26.3	1.00 V	6	27.1	-7.4
4	390.84	23.8 QP	46.0	-22.2	1.50 V	20	28.7	-4.9
5	552.83	27.0 QP	46.0	-19.0	1.00 V	87	28.8	-1.8
6	883.60	31.3 QP	46.0	-14.7	2.00 V	342	26.8	4.5

Remarks:

1. Emission Level(dBuV/m) = Raw Value(dBuV) + Correction Factor(dB/m)
2. Correction Factor(dB/m) = Antenna Factor(dB/m) + Cable Factor(dB) – Pre-Amplifier Factor(dB)
3. Margin value = Emission Level – Limit value
4. The other emission levels were very low against the limit of frequency range 30MHz~1000MHz.
5. The emission levels were very low against the limit of frequency range 9kHz~30MHz: the amplitude of spurious emissions attenuated more than 20 dB below the permissible value to be report.

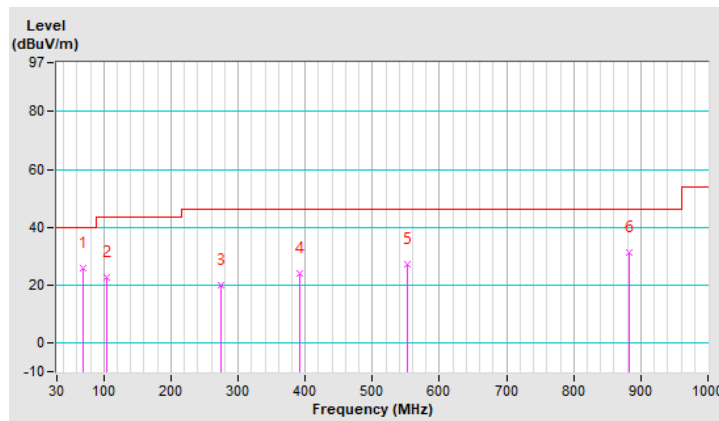

RF Mode	TX 802.11a	Channel	CH 36 : 5180 MHz
Frequency Range	30MHz ~ 1GHz	Detector Function	Quasi-Peak (QP)
Test Mode	B		

Antenna Polarity & Test Distance : Horizontal at 3 m

No	Frequency (MHz)	Emission Level (dBuV/m)	Limit (dBuV/m)	Margin (dB)	Antenna Height (m)	Table Angle (Degree)	Raw Value (dBuV)	Correction Factor (dB/m)
1	34.85	24.2 QP	40.0	-15.8	2.00 H	331	34.4	-10.2
2	89.17	30.6 QP	43.5	-12.9	1.00 H	6	44.9	-14.3
3	142.52	23.5 QP	43.5	-20.0	1.25 H	274	32.1	-8.6
4	224.97	24.4 QP	46.0	-21.6	1.25 H	283	35.3	-10.9
5	426.73	29.2 QP	46.0	-16.8	1.00 H	292	33.3	-4.1
6	632.37	29.5 QP	46.0	-16.5	1.50 H	127	29.3	0.2

Remarks:

1. Emission Level(dBuV/m) = Raw Value(dBuV) + Correction Factor(dB/m)
2. Correction Factor(dB/m) = Antenna Factor(dB/m) + Cable Factor(dB) – Pre-Amplifier Factor(dB)
3. Margin value = Emission Level – Limit value
4. The other emission levels were very low against the limit of frequency range 30MHz~1000MHz.
5. The emission levels were very low against the limit of frequency range 9kHz~30MHz: the amplitude of spurious emissions attenuated more than 20 dB below the permissible value to be report.

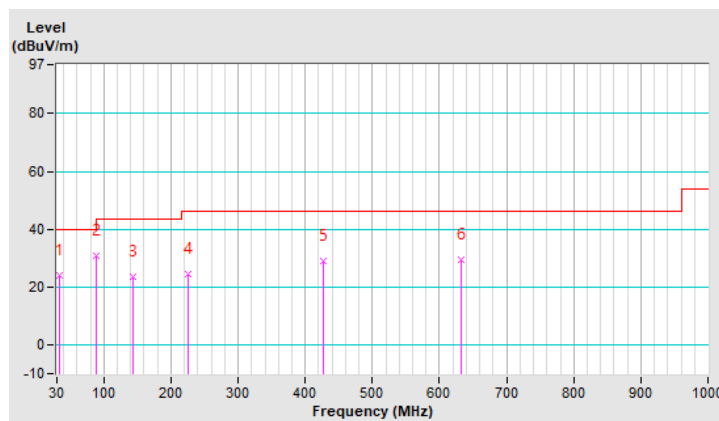

RF Mode	TX 802.11a	Channel	CH 36 : 5180 MHz
Frequency Range	30MHz ~ 1GHz	Detector Function	Quasi-Peak (QP)
Test Mode	B		

Antenna Polarity & Test Distance : Vertical at 3 m								
No	Frequency (MHz)	Emission Level (dBuV/m)	Limit (dBuV/m)	Margin (dB)	Antenna Height (m)	Table Angle (Degree)	Raw Value (dBuV)	Correction Factor (dB/m)
1	30.97	33.8 QP	40.0	-6.2	1.00 V	308	44.4	-10.6
2	54.25	30.0 QP	40.0	-10.0	1.50 V	252	39.2	-9.2
3	120.21	35.6 QP	43.5	-7.9	1.50 V	121	46.4	-10.8
4	324.88	23.7 QP	46.0	-22.3	1.00 V	172	29.9	-6.2
5	432.55	29.1 QP	46.0	-16.9	1.25 V	152	33.0	-3.9
6	612.97	29.3 QP	46.0	-16.7	1.00 V	277	29.5	-0.2

Remarks:

1. Emission Level(dBuV/m) = Raw Value(dBuV) + Correction Factor(dB/m)
2. Correction Factor(dB/m) = Antenna Factor(dB/m) + Cable Factor(dB) – Pre-Amplifier Factor(dB)
3. Margin value = Emission Level – Limit value
4. The other emission levels were very low against the limit of frequency range 30MHz~1000MHz.
5. The emission levels were very low against the limit of frequency range 9kHz~30MHz: the amplitude of spurious emissions attenuated more than 20 dB below the permissible value to be report.

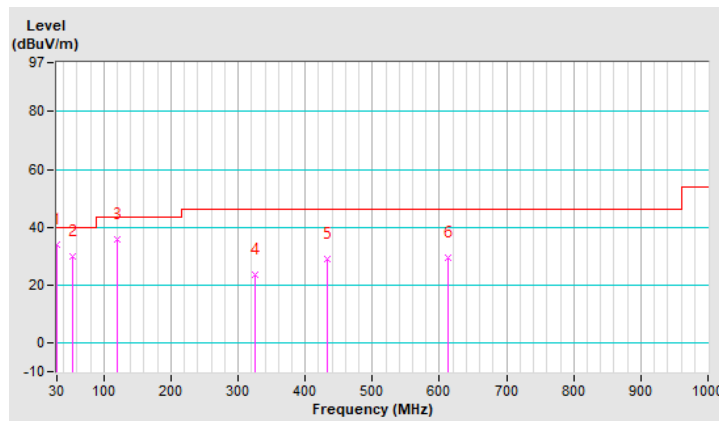

4.2 Conducted Emission Measurement

4.2.1 Limits of Conducted Emission Measurement

Frequency (MHz)	Conducted Limit (dBuV)	
	Quasi-peak	Average
0.15 - 0.5	66 - 56	56 - 46
0.50 - 5.0	56	46
5.0 - 30.0	60	50

Note: 1. The lower limit shall apply at the transition frequencies.

2. The limit decreases in line with the logarithm of the frequency in the range of 0.15 to 0.50MHz.

4.2.2 Test Instruments

Description & Manufacturer	Model No.	Serial No.	Cal. Date	Cal. Due
Test Receiver ROHDE & SCHWARZ	ESR3	102783	Dec. 21, 2020	Dec. 20, 2021
RF signal cable (with 10dB PAD) Woken	5D-FB	Cable-cond2-01	Sep. 04, 2020	Sep. 03, 2021
LISN ROHDE & SCHWARZ (EUT)	ESH2-Z5	100100	Jan. 28, 2021	Jan. 27, 2022
LISN ROHDE & SCHWARZ (Peripheral)	ESH3-Z5	100312	Aug. 18, 2020	Aug. 17, 2021
Software ADT	BV ADT_Cond_ V7.3.7.4	NA	NA	NA

Note: 1. The calibration interval of the above test instruments is 12 months and the calibrations are traceable to NML/ROC and NIST/USA.

2. The test was performed in HwaYa Shielded Room 2 (Conduction 2).

3. The VCCI Site Registration No. is C-12047.

4.2.3 Test Procedures

- The EUT was placed 0.4 meters from the conducting wall of the shielded room with EUT being connected to the power mains through a line impedance stabilization network (LISN). Other support units were connected to the power mains through another LISN. The two LISNs provide 50 ohm/ 50uH of coupling impedance for the measuring instrument.
- Both lines of the power mains connected to the EUT were checked for maximum conducted interference.
- The frequency range from 150kHz to 30MHz was searched. Emission levels under (Limit - 20dB) was not recorded.

Note: The resolution bandwidth and video bandwidth of test receiver is 9kHz for quasi-peak detection (QP) and average detection (AV) at frequency 0.15MHz-30MHz.

4.2.4 Deviation from Test Standard

No deviation.

4.2.5 Test Setup

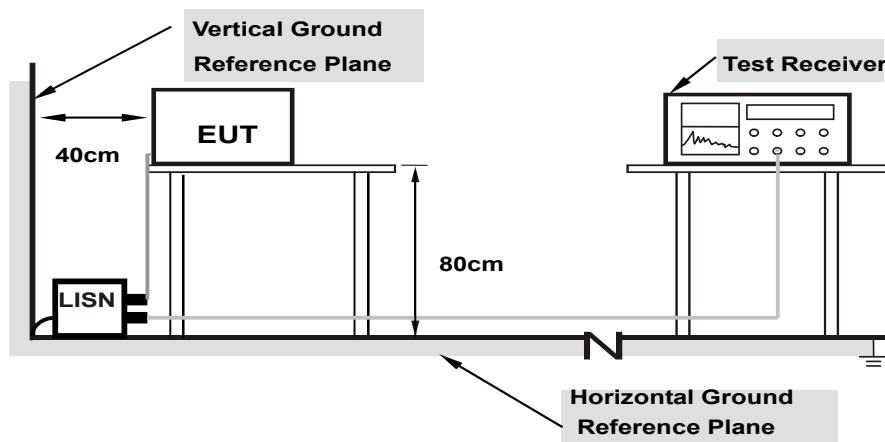

Note: 1.Support units were connected to second LISN.

For the actual test configuration, please refer to the attached file (Test Setup Photo).

4.2.6 EUT Operating Conditions

Same as 4.1.6.

4.2.7 Test Results

Worst-case data:

802.11a

Phase	Line (L)	Detector Function	Quasi-Peak (QP) / Average (AV)
Test Mode	A		

No	Freq. [MHz]	Corr. Factor (dB)	Reading Value [dB (uV)]		Emission Level [dB (uV)]		Limit [dB (uV)]		Margin (dB)	
			Q.P.	AV.	Q.P.	AV.	Q.P.	AV.	Q.P.	AV.
			1	0.17737	10.10	20.13	13.92	30.23	24.02	64.61
2	0.34926	10.16	35.03	9.01	45.19	19.17	58.98	48.98	-13.79	-29.81
3	0.62689	10.21	37.28	25.34	47.49	35.55	56.00	46.00	-8.51	-10.45
4	1.40511	10.27	21.06	7.83	31.33	18.10	56.00	46.00	-24.67	-27.90
5	5.31902	10.40	21.69	11.08	32.09	21.48	60.00	50.00	-27.91	-28.52
6	9.22120	10.47	25.20	15.75	35.67	26.22	60.00	50.00	-24.33	-23.78

Remarks:

1. Q.P. and AV. are abbreviations of quasi-peak and average individually.
2. The emission levels of other frequencies were very low against the limit.
3. Margin value = Emission level - Limit value
4. Correction factor = Insertion loss + Cable loss
5. Emission Level = Correction Factor + Reading Value.

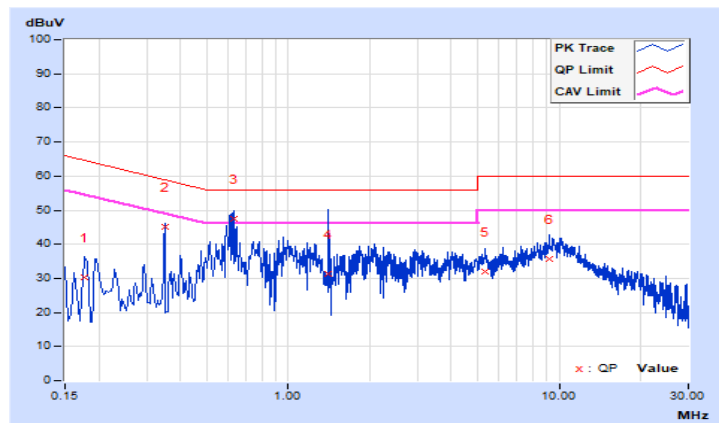

Phase	Neutral (N)	Detector Function	Quasi-Peak (QP) / Average (AV)
Test Mode	A		

No	Freq. [MHz]	Corr. Factor (dB)	Reading Value [dB (uV)]		Emission Level [dB (uV)]		Limit [dB (uV)]		Margin (dB)	
			Q.P.	AV.	Q.P.	AV.	Q.P.	AV.	Q.P.	AV.
			1	0.20474	10.12	33.65	21.38	43.77	31.50	63.42
2	0.28685	10.15	39.06	15.75	49.21	25.90	60.62	50.62	-11.41	-24.72
3	0.62702	10.23	40.53	31.58	50.76	41.81	56.00	46.00	-5.24	-4.19
4	1.21743	10.29	32.51	19.24	42.80	29.53	56.00	46.00	-13.20	-16.47
5	3.06295	10.38	29.29	18.19	39.67	28.57	56.00	46.00	-16.33	-17.43
6	10.26517	10.61	31.77	21.10	42.38	31.71	60.00	50.00	-17.62	-18.29

Remarks:

1. Q.P. and AV. are abbreviations of quasi-peak and average individually.
2. The emission levels of other frequencies were very low against the limit.
3. Margin value = Emission level - Limit value
4. Correction factor = Insertion loss + Cable loss
5. Emission Level = Correction Factor + Reading Value.

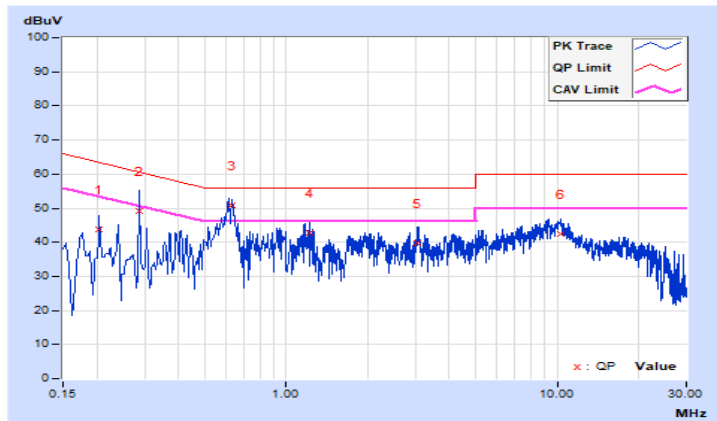

Phase	Line (L)	Detector Function	Quasi-Peak (QP) / Average (AV)
Test Mode	B		

No	Freq. [MHz]	Corr. Factor (dB)	Reading Value		Emission Level		Limit		Margin	
			[dB (uV)]		[dB (uV)]		[dB (uV)]		(dB)	
			Q.P.	AV.	Q.P.	AV.	Q.P.	AV.	Q.P.	AV.
1	0.17328	10.10	45.99	17.04	56.09	27.14	64.80	54.80	-8.71	-27.66
2	0.30214	10.15	25.10	8.30	35.25	18.45	60.18	50.18	-24.93	-31.73
3	0.61529	10.21	38.72	24.86	48.93	35.07	56.00	46.00	-7.07	-10.93
4	0.87372	10.24	29.09	16.94	39.33	27.18	56.00	46.00	-16.67	-18.82
5	1.95251	10.29	25.10	13.06	35.39	23.35	56.00	46.00	-20.61	-22.65
6	8.38837	10.46	23.91	14.16	34.37	24.62	60.00	50.00	-25.63	-25.38

Remarks:

1. Q.P. and AV. are abbreviations of quasi-peak and average individually.
2. The emission levels of other frequencies were very low against the limit.
3. Margin value = Emission level - Limit value
4. Correction factor = Insertion loss + Cable loss
5. Emission Level = Correction Factor + Reading Value.

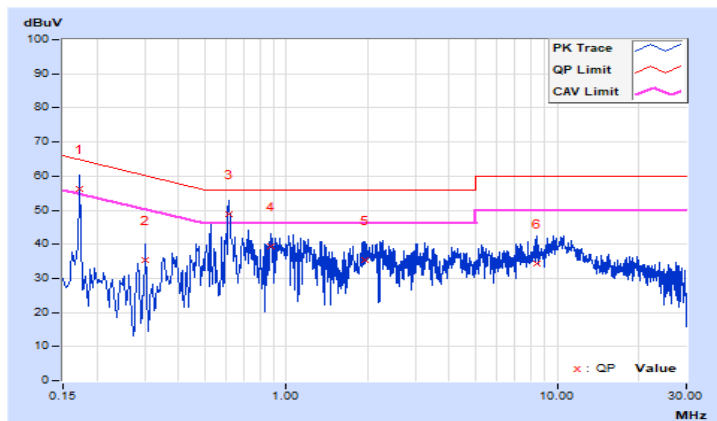

Phase	Neutral (N)	Detector Function	Quasi-Peak (QP) / Average (AV)
Test Mode	B		

No	Freq. [MHz]	Corr. Factor (dB)	Reading Value [dB (uV)]		Emission Level [dB (uV)]		Limit [dB (uV)]		Margin (dB)	
			Q.P.	AV.	Q.P.	AV.	Q.P.	AV.	Q.P.	AV.
			1	0.15782	10.10	48.19	18.49	58.29	28.59	65.58
2	0.22820	10.13	44.43	19.17	54.56	29.30	62.51	52.51	-7.95	-23.21
3	0.62689	10.23	41.22	32.28	51.45	42.51	56.00	46.00	-4.55	-3.49
4	1.23307	10.29	33.37	18.87	43.66	29.16	56.00	46.00	-12.34	-16.84
5	3.03949	10.38	29.65	19.51	40.03	29.89	56.00	46.00	-15.97	-16.11
6	10.53496	10.62	34.43	22.96	45.05	33.58	60.00	50.00	-14.95	-16.42

Remarks:

1. Q.P. and AV. are abbreviations of quasi-peak and average individually.
2. The emission levels of other frequencies were very low against the limit.
3. Margin value = Emission level - Limit value
4. Correction factor = Insertion loss + Cable loss
5. Emission Level = Correction Factor + Reading Value.

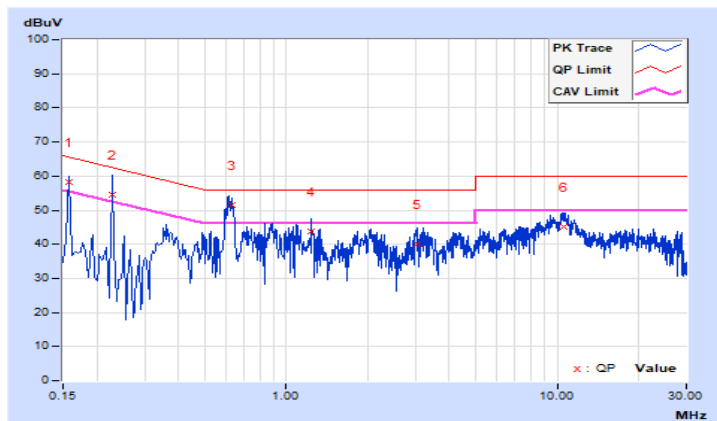

4.3 Transmit Power Measurement

4.3.1 Limits of Transmit Power Measurement

Operation Band	EUT Category		Limit
U-NII-1		Outdoor Access Point	1 Watt (30 dBm) (Max. e.i.r.p \leq 125mW(21 dBm) at any elevation angle above 30 degrees as measured from the horizon)
		Fixed point-to-point Access Point	1 Watt (30 dBm)
		Indoor Access Point	1 Watt (30 dBm)
	√	Mobile and Portable client device	250mW (24 dBm)
U-NII-2A	√		250mW (24 dBm) or 11 dBm+10 log B*
U-NII-2C	√		250mW (24 dBm) or 11 dBm+10 log B*
U-NII-3	√		1 Watt (30 dBm)

*B is the 26 dB emission bandwidth in megahertz

Per KDB 662911 Method of conducted output power measurement on IEEE 802.11 devices,

Array Gain = 0 dB (i.e., no array gain) for $N_{ANT} \leq 4$;

Array Gain = 0 dB (i.e., no array gain) for channel widths ≥ 40 MHz for any N_{ANT} ;

Array Gain = $5 \log(N_{ANT}/N_{SS})$ dB or 3 dB, whichever is less for 20-MHz channel widths with $N_{ANT} \geq 5$.

For power measurements on all other devices: Array Gain = $10 \log(N_{ANT}/N_{SS})$ dB.

4.3.2 Test Setup

For Power Output

802.11a, 802.11ac (VHT20), 802.11ac (VHT40)

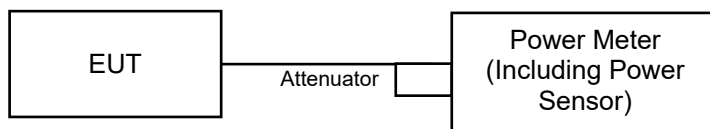

For 802.11ac (VHT80) and straddle channels

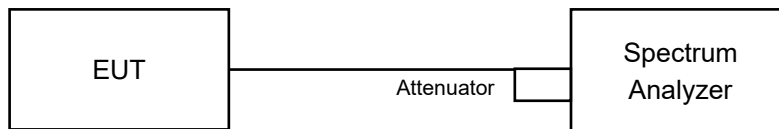

For 26dB Bandwidth

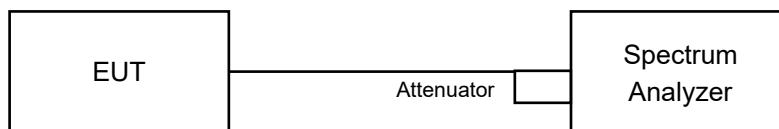

4.3.3 Test Instruments

Refer to section 4.1.2 to get information of above instrument.

4.3.4 Test Procedure

For Average Power Measurement

Method PM is used to perform output power measurement, trigger and gating function of wide band power meter is enabled to measure max output power of TX on burst and set the detector to average. Duty factor is not added to measured value.

For 802.11a, 802.11ac (VHT20), 802.11ac (VHT40)

Method PM is used to perform output power measurement, trigger and gating function of wide band power meter is enabled to measure max output power of TX on burst. Duty factor is not added to measured value.

For 802.11ac (VHT80) and straddle channels

Method SA-1 (trace averaging with the EUT transmitting at full power throughout each sweep):

- a. Set span to encompass the entire emission bandwidth (EBW) (or, alternatively, the entire 99% occupied bandwidth) of the signal.
- b. Set RBW = 1 MHz.
- c. Set VBW \geq 3 MHz.
- d. Number of points in sweep $\geq 2 \times$ span / RBW. (This ensures that bin-to-bin spacing is \leq RBW/2, so that narrowband signals are not lost between frequency bins.)
- e. Sweep time = auto.
- f. Detector = power averaging (rms), if available. Otherwise, use sample detector mode.
- g. If transmit duty cycle $<$ 98%, use a video trigger with the trigger level set to enable triggering only on full power pulses. Transmitter must operate at maximum power control level for the entire duration of every sweep. If the EUT transmits continuously (i.e., with no off intervals) or at duty cycle \geq 98%, and if each transmission is entirely at the maximum power control level, then the trigger shall be set to "free run."
- h. Trace average at least 100 traces in power averaging (rms) mode.
- i. Compute power by integrating the spectrum across the EBW (or, alternatively, the entire 99% occupied bandwidth) of the signal using the instrument's band power measurement function with band limits set equal to the EBW (or occupied bandwidth) band edges. If the instrument does not have a band power function, sum the spectrum levels (in power units) at 1 MHz intervals extending across the EBW (or, alternatively, the entire 99% occupied bandwidth) of the spectrum.

For 26dB Bandwidth

- a. Set RBW = approximately 1% of the emission bandwidth.
- b. Set the VBW $>$ RBW.
- c. Detector = Peak.
- d. Trace mode = max hold.
- e. Measure the maximum width of the emission that is 26 dB down from the peak of the emission. Compare this with the RBW setting of the analyzer. Readjust RBW and repeat measurement as needed until the RBW/EBW ratio is approximately 1%.
- f. For channel aggregation (channel 138, 142, 144) measurement refer to KDB 789033 D02 Section III. CHANNEL AGGREGATION.

4.3.5 Deviation from Test Standard

No deviation.

4.3.6 EUT Operating Conditions

The software provided by client to enable the EUT under transmission condition continuously at lowest, middle and highest channel frequencies individually.

4.3.7 Test Result

Power Output:
802.11a

Chan.	Freq. (MHz)	Maximum Conducted Power (dBm)		Total Power (mW)	Total Power (dBm)	Power Limit (dBm)	Pass / Fail
		Chain 0	Chain 1				
36	5180	9.68	11.51	23.448	13.70	24.00	Pass
40	5200	10.04	11.39	23.865	13.78	24.00	Pass
48	5240	10.00	11.54	24.256	13.85	24.00	Pass
52	5260	13.22	14.83	51.398	17.11	24.00	Pass
60	5300	13.22	14.72	50.638	17.04	24.00	Pass
64	5320	13.21	14.82	51.280	17.10	24.00	Pass
100	5500	14.31	14.12	52.800	17.23	24.00	Pass
116	5580	14.27	14.19	52.972	17.24	24.00	Pass
140	5700	14.40	14.24	54.088	17.33	24.00	Pass
144	5720 (For U-NII-2C)	13.59	13.69	46.244	16.65	23.23	Pass
144	5720 (For U-NII-3)	5.93	4.62	6.815	8.33	30.00	Pass
149	5745	13.76	14.41	51.374	17.11	30.00	Pass
157	5785	12.67	15.17	51.378	17.11	30.00	Pass
165	5825	13.62	14.57	51.656	17.13	30.00	Pass

Note:

For U-NII-2A, U-NII-2C Band:

Chain 0

1. $11\text{dBm} + 10\log(23.93) = 24.78 > 24\text{dBm}$
2. $11\text{dBm} + 10\log(24.23) = 24.84 > 24\text{dBm}$
3. $11\text{dBm} + 10\log(24.00) = 24.80 > 24\text{dBm}$
4. $11\text{dBm} + 10\log(24.23) = 24.84 > 24\text{dBm}$
5. $11\text{dBm} + 10\log(23.76) = 24.75 > 24\text{dBm}$
6. $11\text{dBm} + 10\log(23.59) = 24.72 > 24\text{dBm}$
7. $11\text{dBm} + 10\log(5725.00 - 5708.02) = 23.29 < 24\text{dBm}$

Chain 1

1. $11\text{dBm} + 10\log(23.62) = 24.73 > 24\text{dBm}$
2. $11\text{dBm} + 10\log(23.83) = 24.77 > 24\text{dBm}$
3. $11\text{dBm} + 10\log(23.48) = 24.70 > 24\text{dBm}$
4. $11\text{dBm} + 10\log(23.77) = 24.76 > 24\text{dBm}$
5. $11\text{dBm} + 10\log(24.64) = 24.91 > 24\text{dBm}$
6. $11\text{dBm} + 10\log(24.04) = 24.80 > 24\text{dBm}$
7. $11\text{dBm} + 10\log(5725.00 - 5708.27) = 23.23 < 24\text{dBm}$

802.11ac (VHT20)

Chan.	Freq. (MHz)	Maximum Conducted Power (dBm)		Total Power (mW)	Total Power (dBm)	Power Limit (dBm)	Pass / Fail
		Chain 0	Chain 1				
36	5180	9.90	11.75	24.735	13.93	24.00	Pass
40	5200	9.89	11.83	24.990	13.98	24.00	Pass
48	5240	10.04	11.84	25.368	14.04	24.00	Pass
52	5260	12.24	14.07	42.276	16.26	24.00	Pass
60	5300	12.34	14.03	42.433	16.28	24.00	Pass
64	5320	12.86	13.72	42.870	16.32	24.00	Pass
100	5500	13.29	13.10	41.748	16.21	24.00	Pass
116	5580	13.33	13.21	42.469	16.28	24.00	Pass
140	5700	13.44	13.34	43.657	16.40	24.00	Pass
144	5720 (For U-NII-2C)	12.51	12.63	36.147	15.58	23.44	Pass
144	5720 (For U-NII-3)	4.50	4.21	5.455	7.37	30.00	Pass
149	5745	12.85	13.93	43.992	16.43	30.00	Pass
157	5785	12.15	14.36	43.696	16.40	30.00	Pass
165	5825	13.08	13.79	44.257	16.46	30.00	Pass

Note:

For U-NII-2A, U-NII-2C Band:

Chain 0

1. $11\text{dBm} + 10\log(24.69) = 24.92 > 24\text{dBm}$
2. $11\text{dBm} + 10\log(24.81) = 24.94 > 24\text{dBm}$
3. $11\text{dBm} + 10\log(24.26) = 24.84 > 24\text{dBm}$
4. $11\text{dBm} + 10\log(24.55) = 24.90 > 24\text{dBm}$
5. $11\text{dBm} + 10\log(24.94) = 24.96 > 24\text{dBm}$
6. $11\text{dBm} + 10\log(25.19) = 25.01 > 24\text{dBm}$
7. $11\text{dBm} + 10\log(5725.00 - 5707.45) = 23.44 < 24\text{dBm}$

Chain 1

1. $11\text{dBm} + 10\log(25.60) = 25.08 > 24\text{dBm}$
2. $11\text{dBm} + 10\log(24.90) = 24.96 > 24\text{dBm}$
3. $11\text{dBm} + 10\log(24.13) = 24.82 > 24\text{dBm}$
4. $11\text{dBm} + 10\log(24.95) = 24.97 > 24\text{dBm}$
5. $11\text{dBm} + 10\log(25.22) = 25.01 > 24\text{dBm}$
6. $11\text{dBm} + 10\log(25.38) = 25.04 > 24\text{dBm}$
7. $11\text{dBm} + 10\log(5725.00 - 5707.43) = 23.44 < 24\text{dBm}$

802.11ac (VHT40)

Chan.	Freq. (MHz)	Maximum Conducted Power (dBm)		Total Power (mW)	Total Power (dBm)	Power Limit (dBm)	Pass / Fail
		Chain 0	Chain 1				
38	5190	11.44	12.76	32.811	15.16	24.00	Pass
46	5230	11.84	12.97	35.091	15.45	24.00	Pass
54	5270	11.83	12.92	34.829	15.42	24.00	Pass
62	5310	11.38	12.72	32.447	15.11	24.00	Pass
102	5510	12.43	12.32	34.559	15.39	24.00	Pass
110	5550	12.25	12.09	32.969	15.18	24.00	Pass
134	5670	12.23	12.06	32.780	15.16	24.00	Pass
142	5710 (For U-NII-2C)	10.98	11.56	26.853	14.29	24.00	Pass
142	5710 (For U-NII-3)	3.40	2.85	4.115	6.14	30.00	Pass
151	5755	12.39	12.29	34.281	15.35	30.00	Pass
159	5795	10.73	13.27	33.063	15.19	30.00	Pass

Note:

For U-NII-2A, U-NII-2C Band:

Chain 0

1. $11\text{dBm} + 10\log(42.53) = 27.28 > 24\text{dBm}$
2. $11\text{dBm} + 10\log(42.51) = 27.28 > 24\text{dBm}$
3. $11\text{dBm} + 10\log(42.59) = 27.29 > 24\text{dBm}$
4. $11\text{dBm} + 10\log(42.51) = 27.28 > 24\text{dBm}$
5. $11\text{dBm} + 10\log(42.47) = 27.28 > 24\text{dBm}$
6. $11\text{dBm} + 10\log(5725.00 - 5688.77) = 26.59 > 24\text{dBm}$

Chain 1

1. $11\text{dBm} + 10\log(42.36) = 27.26 > 24\text{dBm}$
2. $11\text{dBm} + 10\log(42.67) = 27.30 > 24\text{dBm}$
3. $11\text{dBm} + 10\log(42.58) = 27.29 > 24\text{dBm}$
4. $11\text{dBm} + 10\log(42.31) = 27.26 > 24\text{dBm}$
5. $11\text{dBm} + 10\log(42.35) = 27.26 > 24\text{dBm}$
6. $11\text{dBm} + 10\log(5725.00 - 5688.87) = 26.57 > 24\text{dBm}$

802.11ac (VHT80)

Chan.	Freq. (MHz)	Maximum Conducted Power (dBm)		Total Power (mW)	Total Power (dBm)	Power Limit (dBm)	Pass / Fail
		Chain 0	Chain 1				
42	5210	11.73	12.96	34.663	15.40	24.00	Pass
58	5290	12.22	12.04	32.668	15.14	24.00	Pass
106	5530	12.26	12.21	33.461	15.25	24.00	Pass
122	5610	12.23	12.04	32.706	15.15	24.00	Pass
138	5690 (For U-NII-2C)	11.80	11.63	29.690	14.73	24.00	Pass
138	5690 (For U-NII-3)	1.50	1.39	2.790	4.46	30.00	Pass
155	5775	11.52	13.16	34.892	15.43	30.00	Pass

Note:

For U-NII-2A, U-NII-2C Band:

Chain 0

1. $11\text{dBm} + 10\log(84.44) = 30.26 > 24\text{dBm}$
2. $11\text{dBm} + 10\log(83.83) = 30.23 > 24\text{dBm}$
3. $11\text{dBm} + 10\log(84.25) = 30.25 > 24\text{dBm}$
4. $11\text{dBm} + 10\log(5725.00 - 5648.25) = 29.85 > 24\text{dBm}$

Chain 1

1. $11\text{dBm} + 10\log(84.96) = 30.29 > 24\text{dBm}$
2. $11\text{dBm} + 10\log(84.67) = 30.27 > 24\text{dBm}$
3. $11\text{dBm} + 10\log(84.70) = 30.27 > 24\text{dBm}$
4. $11\text{dBm} + 10\log(5725.00 - 5648.12) = 29.85 > 24\text{dBm}$

Straddle channel power plots:

802.11a

Chain 0

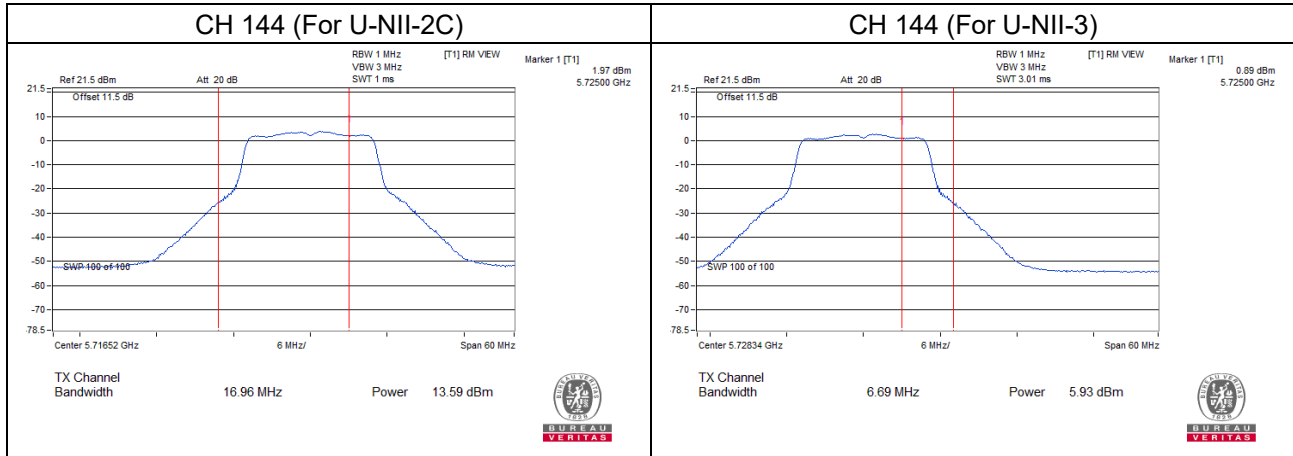

Chain 1

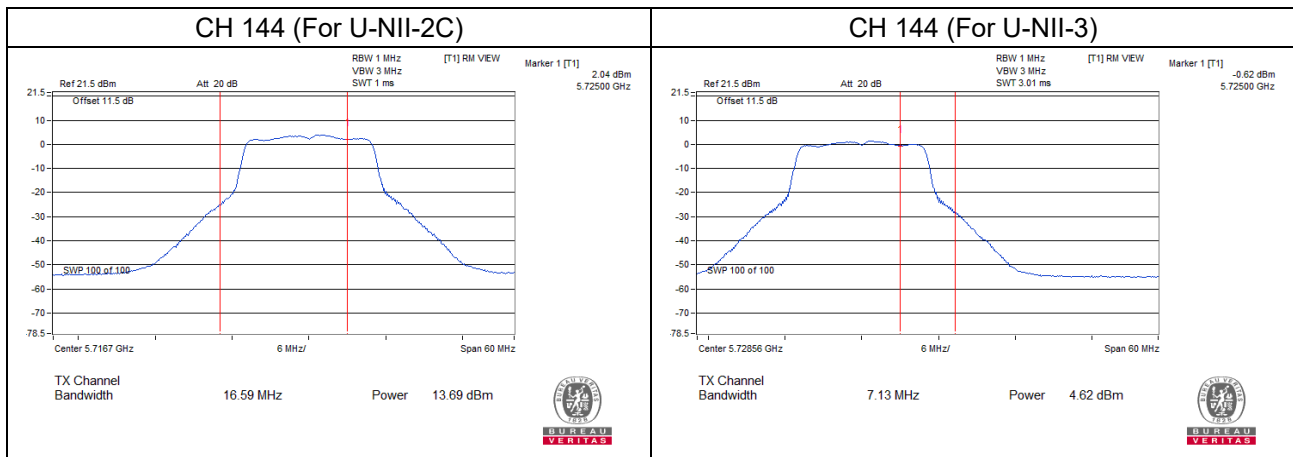

802.11ac (VHT20)

Chain 0

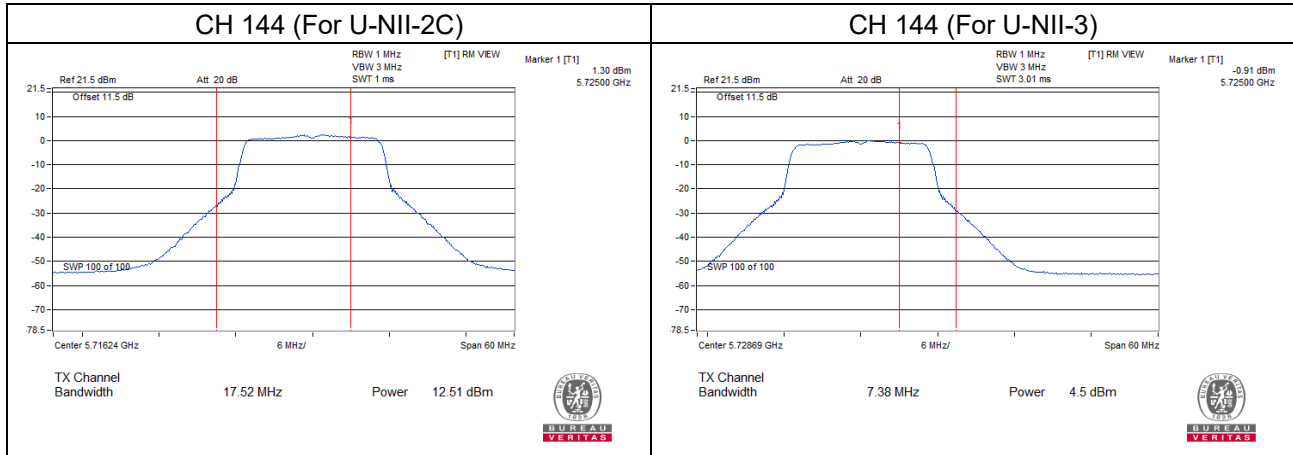

Chain 1

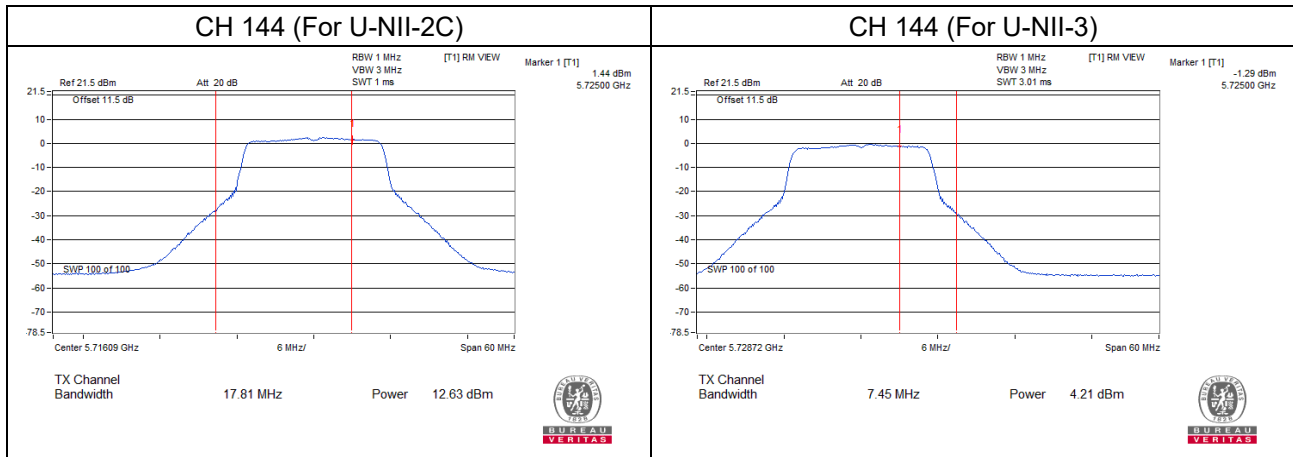

802.11ac (VHT40)
Chain 0

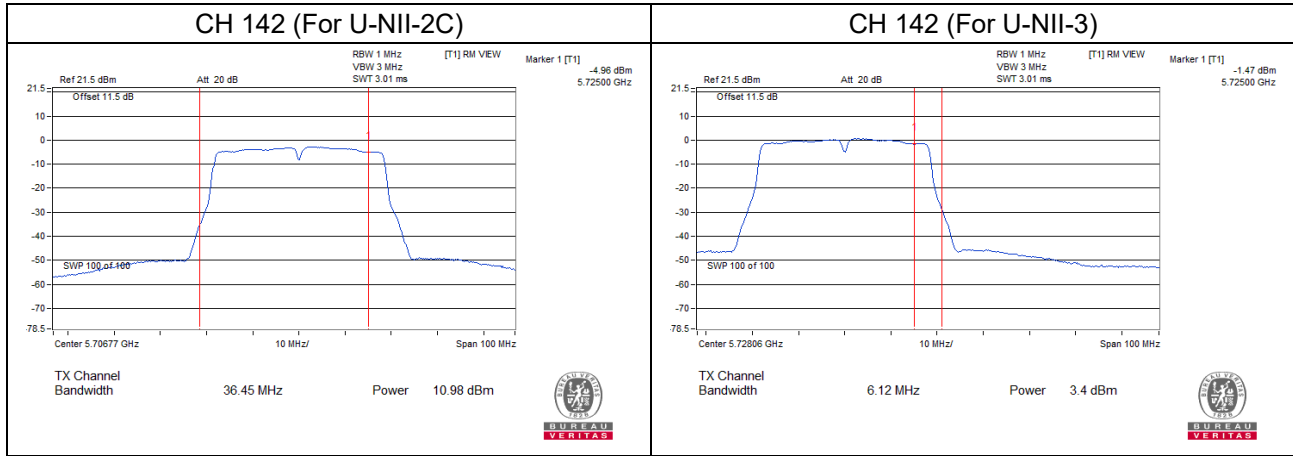

Chain 1

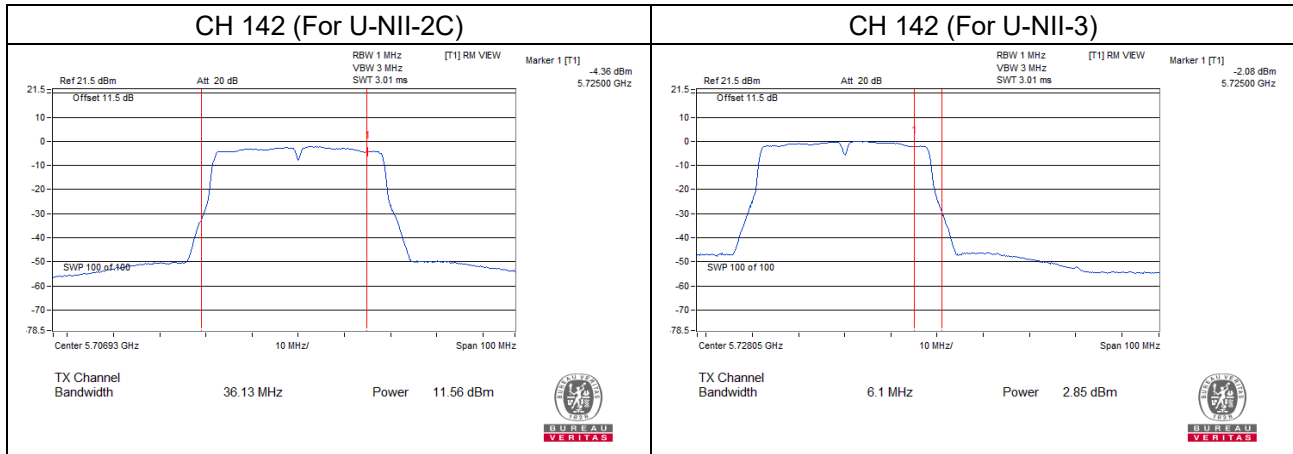

802.11ac (VHT80)
Chain 0

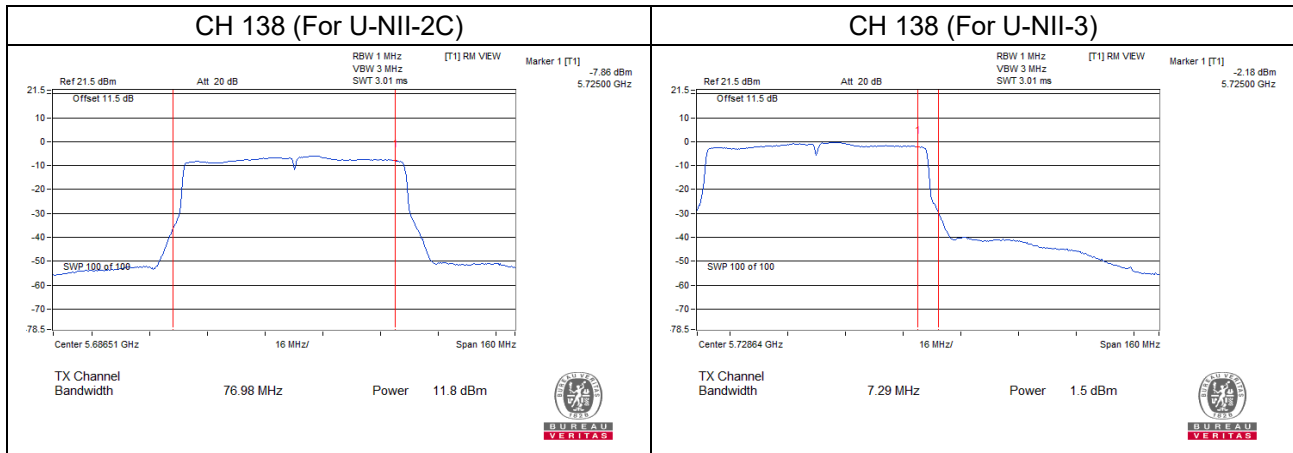

Chain 1

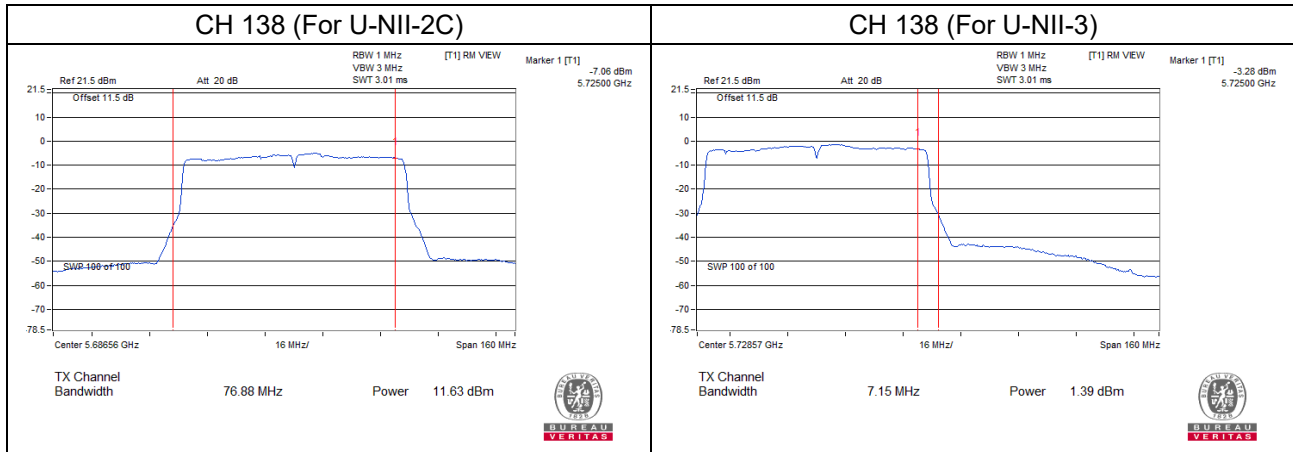

26dB Bandwidth:

802.11a

Chan.	Freq. (MHz)	26dBc Bandwidth (MHz)	
		Chain 0	Chain 1
52	5260	23.93	23.62
60	5300	24.23	23.83
64	5320	24.00	23.48
100	5500	24.23	23.77
116	5580	23.76	24.64
140	5700	23.59	24.04
144	5720 (For U-NII-2C)	16.98	16.73
144	5720 (For U-NII-3)	7.16	7.04

802.11ac (VHT20)

Chan.	Freq. (MHz)	26dBc Bandwidth (MHz)	
		Chain 0	Chain 1
52	5260	24.69	25.60
60	5300	24.81	24.90
64	5320	24.26	24.13
100	5500	24.55	24.95
116	5580	24.94	25.22
140	5700	25.19	25.38
144	5720 (For U-NII-2C)	17.55	17.57
144	5720 (For U-NII-3)	7.46	7.52

802.11ac (VHT40)

Chan.	Freq. (MHz)	26dBc Bandwidth (MHz)	
		Chain 0	Chain 1
54	5270	42.53	42.36
62	5310	42.51	42.67
102	5510	42.59	42.58
110	5550	42.51	42.31
134	5670	42.47	42.35
142	5710 (For U-NII-2C)	36.23	36.13
142	5710 (For U-NII-3)	6.00	6.10

802.11ac (VHT80)

Chan.	Freq. (MHz)	26dBc Bandwidth (MHz)	
		Chain 0	Chain 1
58	5290	84.44	84.96
106	5530	83.83	84.67
122	5610	84.25	84.70
138	5690 (For U-NII-2C)	76.75	76.88
138	5690 (For U-NII-3)	7.03	7.15

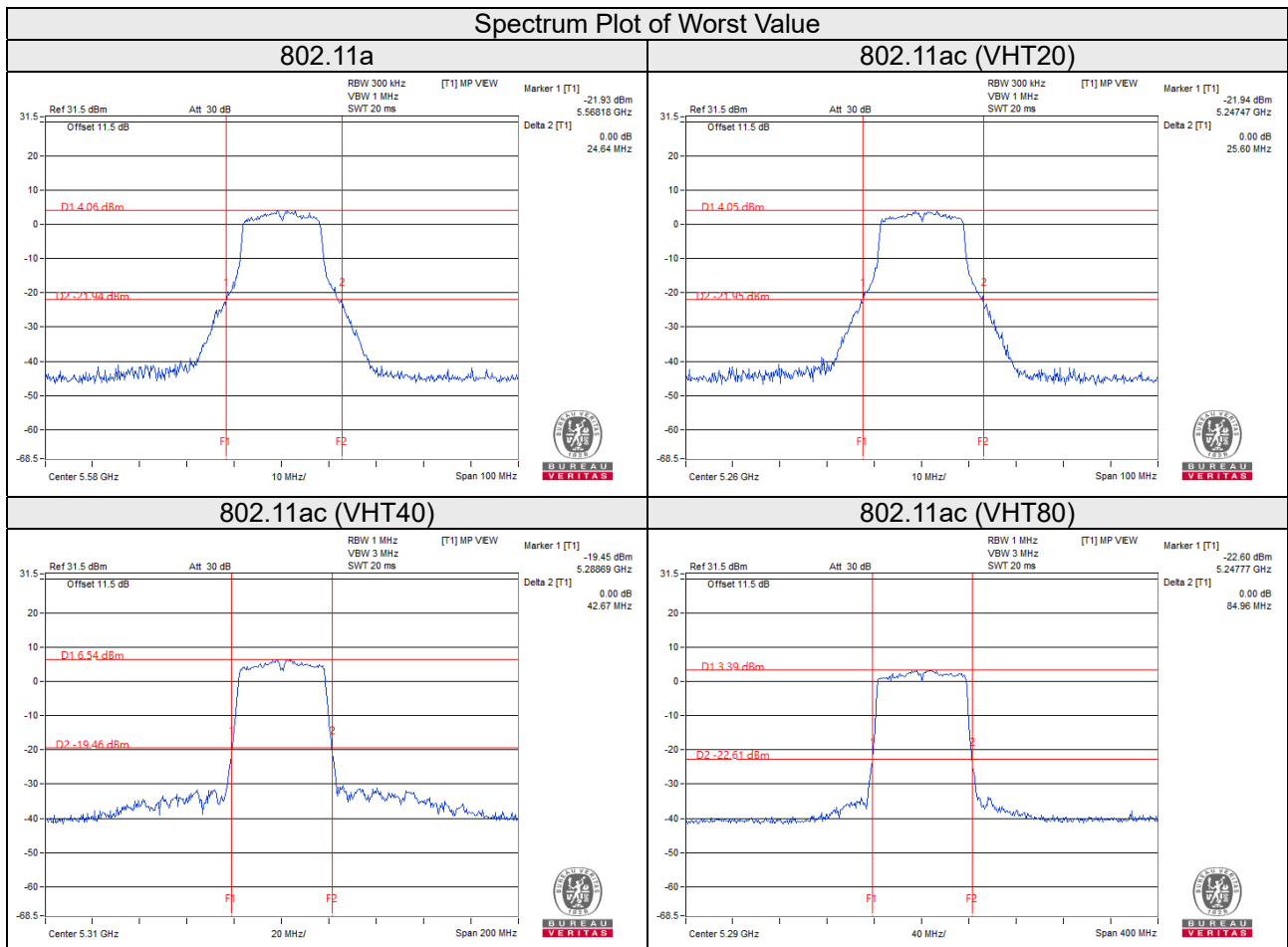

EUT Maximum Conducted Power

802.11a

Frequency Band (MHz)	Max. Power	
	Output Power (mW)	Output Power (dBm)
5250~5350	51.398	17.11
5470~5725	54.088	17.33

802.11ac (VHT20)

Frequency Band (MHz)	Max. Power	
	Output Power (mW)	Output Power (dBm)
5250~5350	42.870	16.32
5470~5725	43.657	16.40

802.11ac (VHT40)

Frequency Band (MHz)	Max. Power	
	Output Power (mW)	Output Power (dBm)
5250~5350	34.829	15.42
5470~5725	34.559	15.39

802.11ac (VHT80)

Frequency Band (MHz)	Max. Power	
	Output Power (mW)	Output Power (dBm)
5250~5350	32.668	15.14
5470~5725	33.461	15.25

4.4 Occupied Bandwidth Measurement

4.4.1 Test Setup

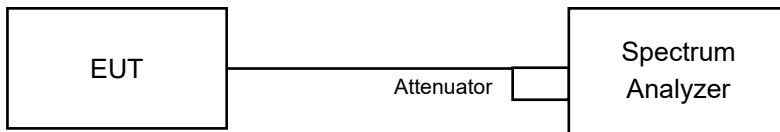

4.4.2 Test Instruments

Refer to section 4.1.2 to get information of above instrument.

4.4.3 Test Procedure

The transmitter output was connected to the spectrum analyzer through an attenuator. The bandwidth of the fundamental frequency was measured by spectrum analyzer with resolution bandwidth in the range of 1% to 5% of the anticipated emission bandwidth, and a video bandwidth at least 3x the resolution bandwidth and set the detector to sampling. The width of a frequency band such that, below the lower and above the upper frequency limits, the mean powers emitted are each equal to a specified percentage 0.5 %of the total mean power of a given emission.

4.4.4 Test Result

802.11a

Chan.	Freq. (MHz)	Occupied Bandwidth (MHz)	
		Chain 0	Chain 1
36	5180	16.80	16.68
40	5200	16.92	16.68
48	5240	16.80	16.68
52	5260	16.92	16.92
60	5300	16.80	16.80
64	5320	16.80	16.80
100	5500	16.68	16.80
116	5580	16.92	16.92
140	5700	16.92	16.80
144	5720 (For U-NII-2C)	13.52	13.52
144	5720 (For U-NII-3)	3.40	3.40
149	5745	16.80	16.92
157	5785	16.92	16.92
165	5825	16.68	16.92

802.11ac (VHT20)

Chan.	Freq. (MHz)	Occupied Bandwidth (MHz)	
		Chain 0	Chain 1
36	5180	17.88	17.88
40	5200	17.88	17.88
48	5240	17.88	17.88
52	5260	17.88	17.88
60	5300	17.88	17.88
64	5320	17.88	17.88
100	5500	17.88	17.88
116	5580	17.88	17.88
140	5700	17.88	18.00
144	5720 (For U-NII-2C)	14.00	14.12
144	5720 (For U-NII-3)	4.00	3.88
149	5745	17.88	17.88
157	5785	17.88	18.00
165	5825	17.88	18.12

802.11ac (VHT40)

Chan.	Freq. (MHz)	Occupied Bandwidth (MHz)	
		Chain 0	Chain 1
38	5190	36.48	36.60
46	5230	36.48	36.60
54	5270	36.60	36.60
62	5310	36.60	36.60
102	5510	36.60	36.60
110	5550	36.60	36.60
134	5670	36.48	36.60
142	5710 (For U-NII-2C)	33.36	33.24
142	5710 (For U-NII-3)	3.12	3.00
151	5755	36.60	36.60
159	5795	36.60	36.60

802.11ac (VHT80)

Chan.	Freq. (MHz)	Occupied Bandwidth (MHz)	
		Chain 0	Chain 1
42	5210	75.84	75.84
58	5290	75.84	75.84
106	5530	75.84	75.84
122	5610	75.60	75.60
138	5690 (For U-NII-2C)	72.92	72.92
138	5690 (For U-NII-3)	2.68	2.92
155	5775	76.08	76.08

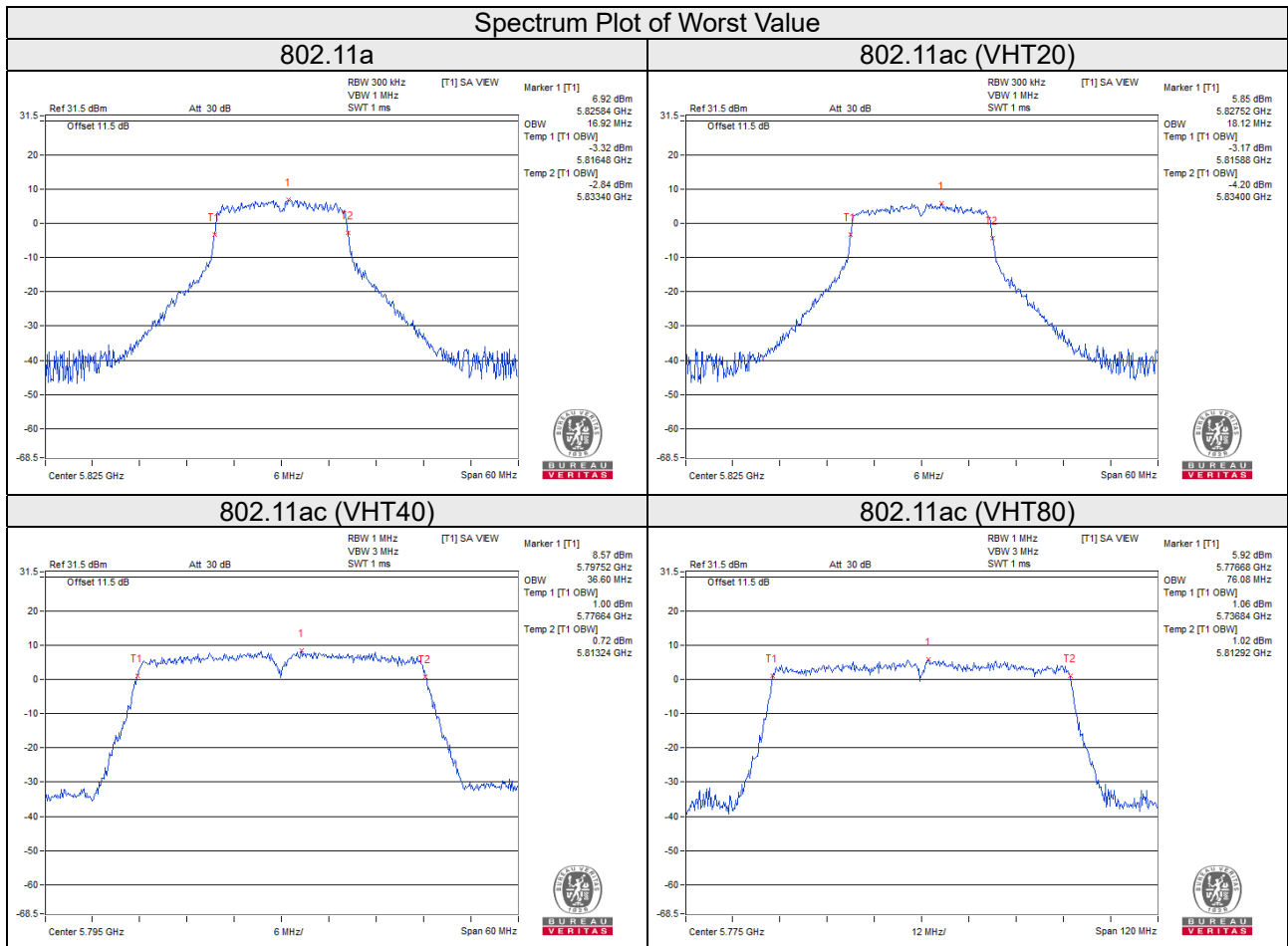

Spectrum Plot for near By DFS Band

802.11a / Chain 0 / CH 48

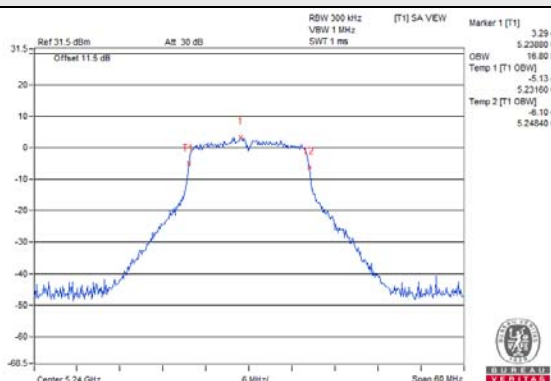

802.11a / Chain 1 / CH 48

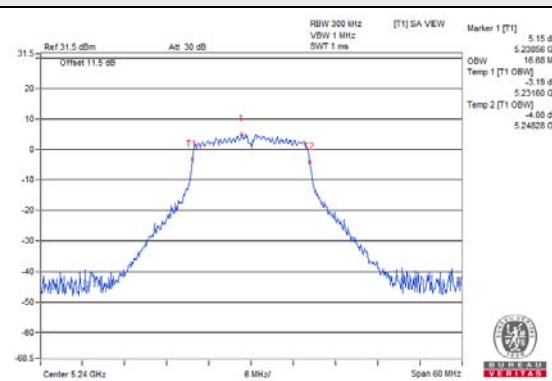

802.11ac (VHT20) / Chain 0 / CH 48

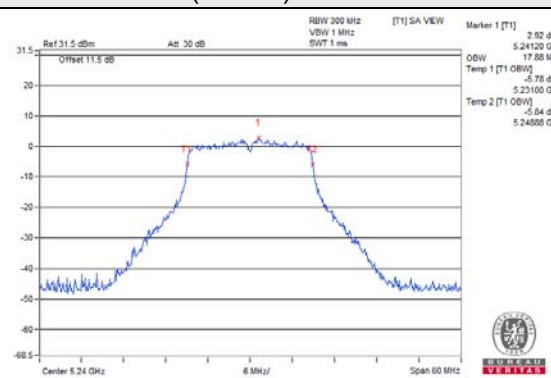

802.11ac (VHT20) / Chain 1 / CH 48

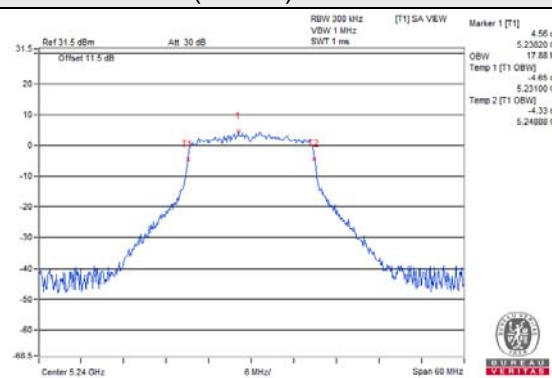

802.11ac (VHT40) / Chain 0 / CH 46

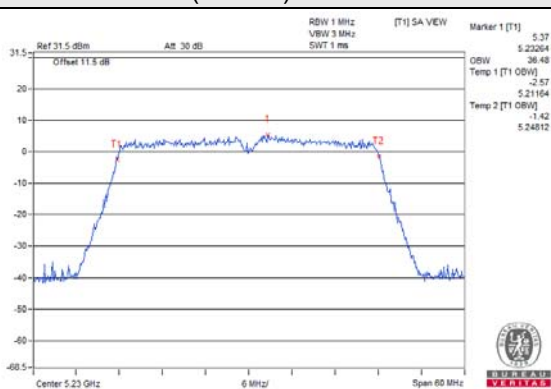

802.11ac (VHT40) / Chain 1 / CH 46

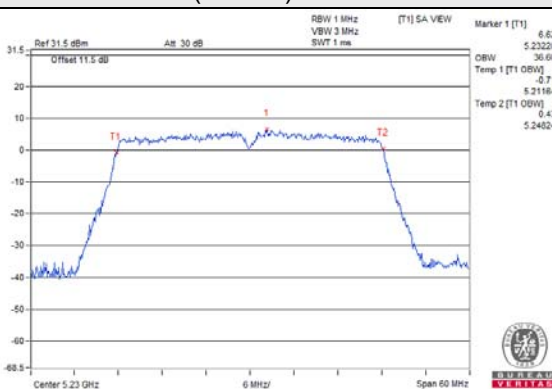

802.11ac (VHT80) / Chain 0 / CH 42

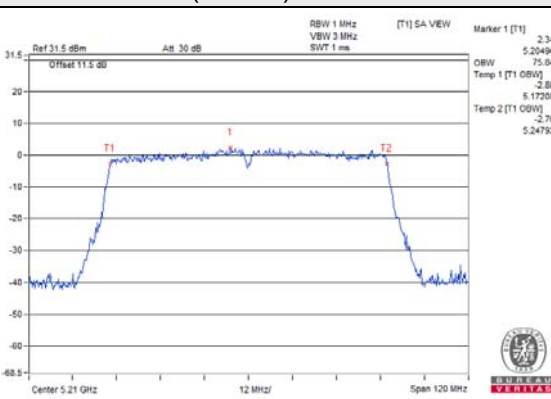

802.11ac (VHT80) / Chain 1 / CH 42

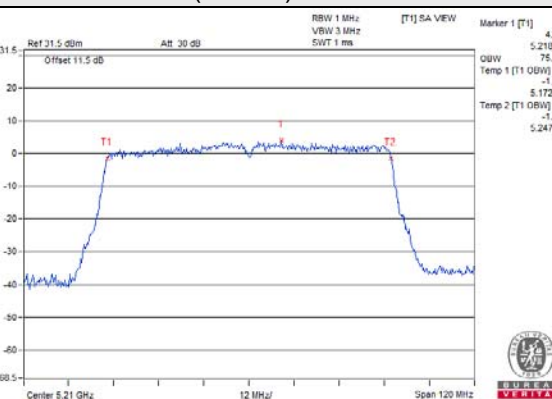

Spectrum Plot for near By DFS Band

802.11a / Chain 0 / CH 149

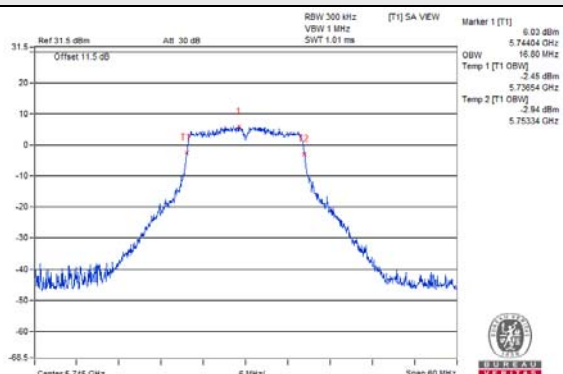

802.11a / Chain 1 / CH 149

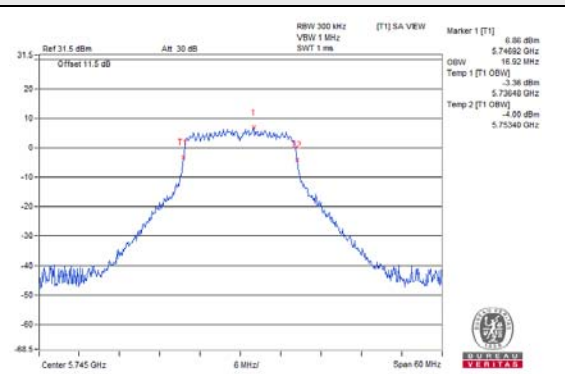

802.11ac (VHT20) / Chain 0 / CH 149

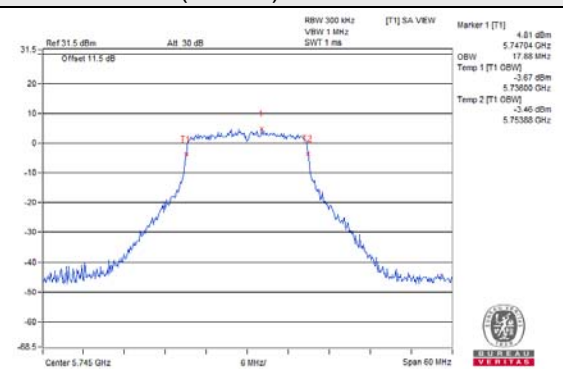

802.11ac (VHT20) / Chain 1 / CH 149

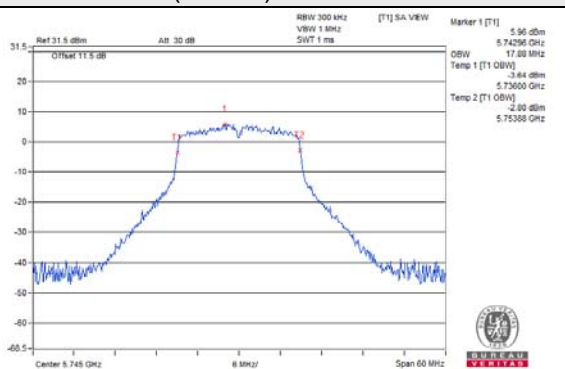

802.11ac (VHT40) / Chain 0 / CH 151

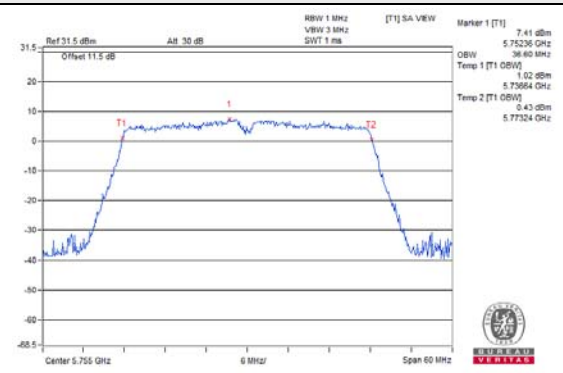

802.11ac (VHT40) / Chain 1 / CH 151

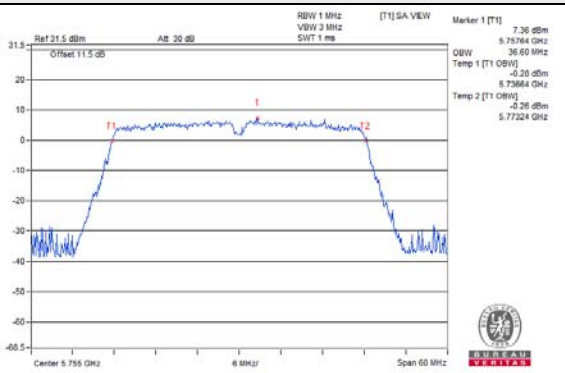

802.11ac (VHT80) / Chain 0 / CH 155

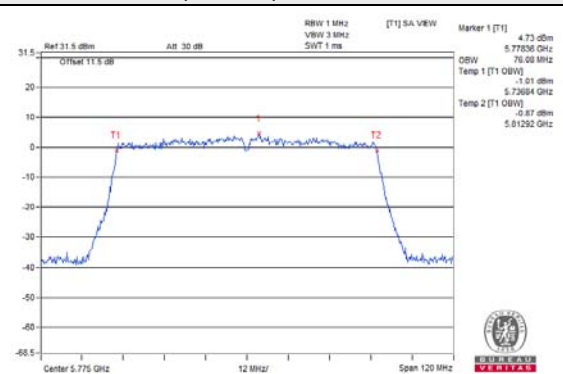

802.11ac (VHT80) / Chain 1 / CH 155

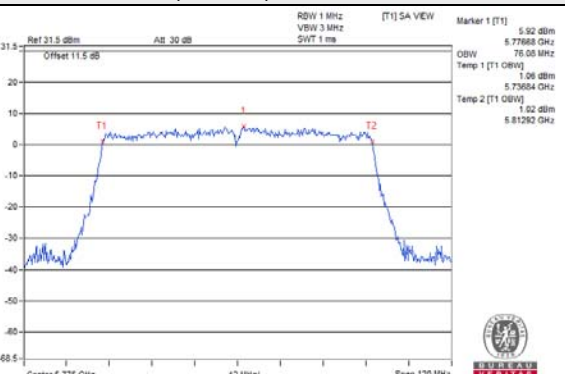

Spectrum Plot of straddle channels

802.11a / Chain 0 / CH 144

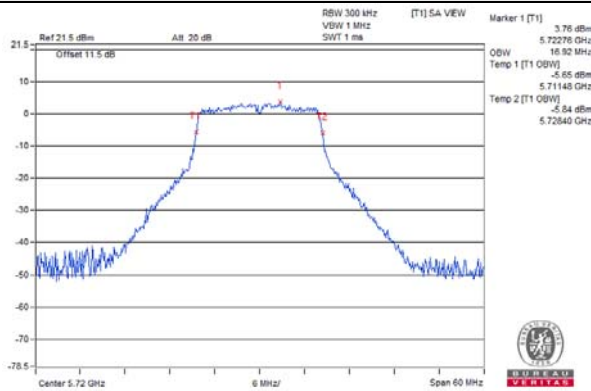

802.11a / Chain 1 / CH 144

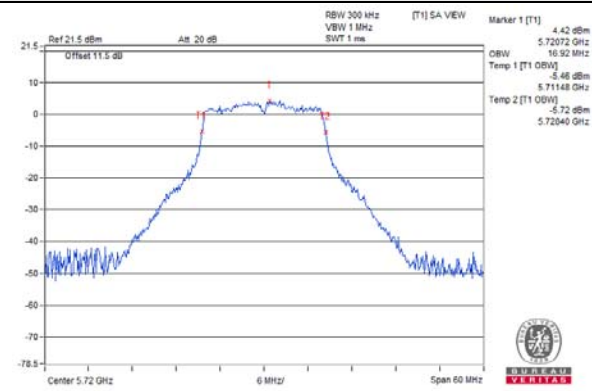

802.11ac (VHT20) / Chain 0 / CH 144

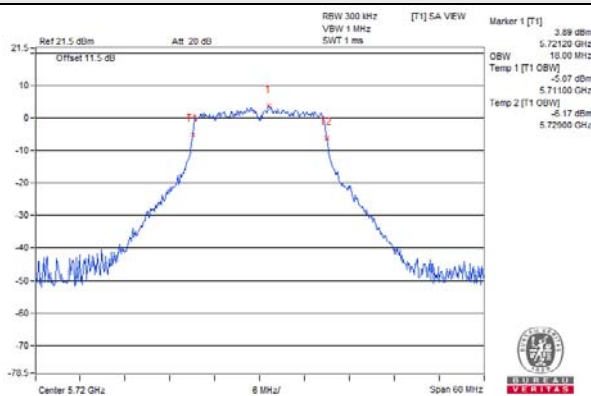

802.11ac (VHT20) / Chain 1 / CH 144

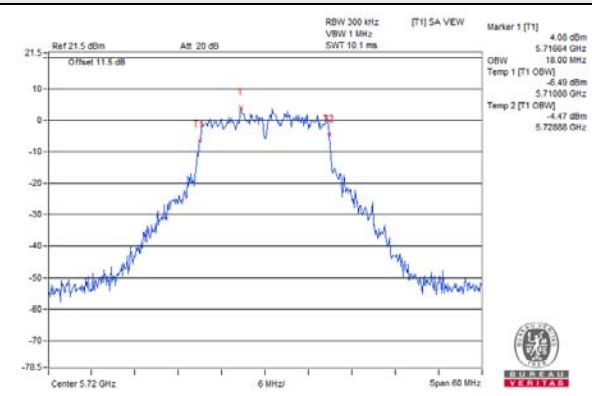

802.11ac (VHT40) / Chain 0 / CH 142

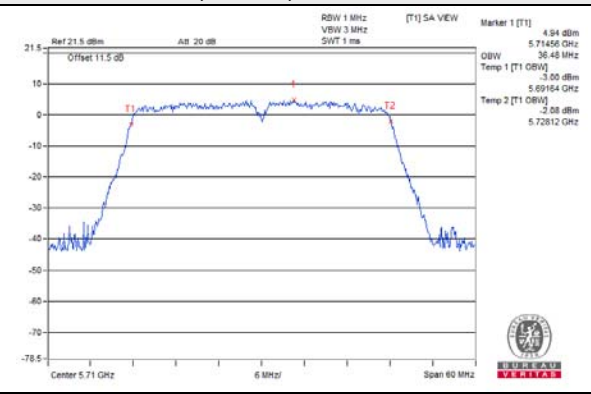

802.11ac (VHT40) / Chain 1 / CH 142

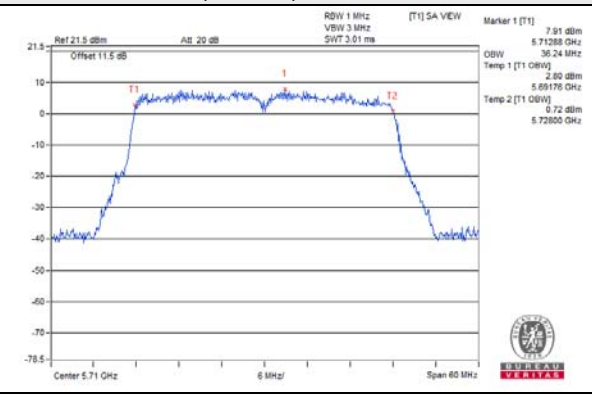

802.11ac (VHT80) / Chain 0 / CH 138

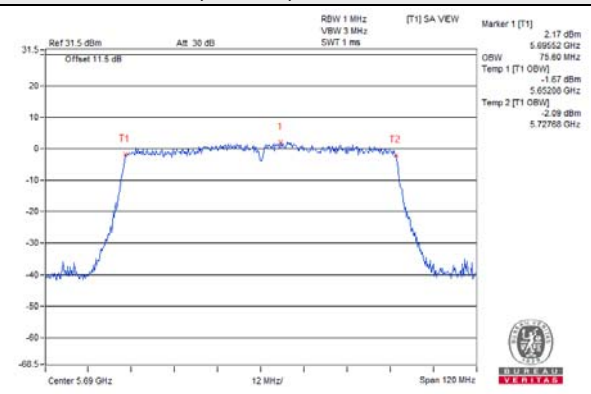

802.11ac (VHT80) / Chain 1 / CH 138

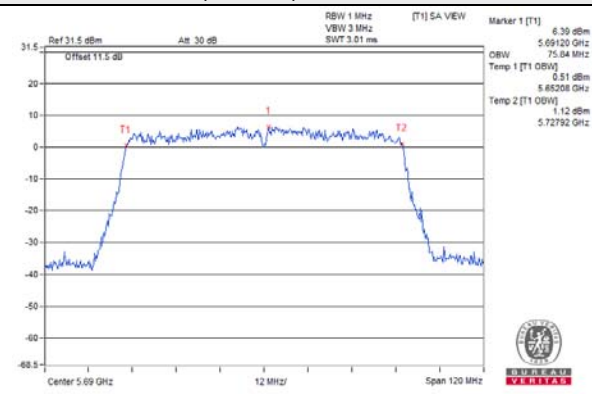

4.5 Peak Power Spectral Density Measurement

4.5.1 Limits of Peak Power Spectral Density Measurement

Operation Band	EUT Category		Limit
U-NII-1		Outdoor Access Point	17dBm/ MHz
		Fixed point-to-point Access Point	
		Indoor Access Point	
	√	Mobile and Portable client device	11dBm/ MHz
U-NII-2A	√		11dBm/ MHz
U-NII-2C	√		11dBm/ MHz
U-NII-3	√		30dBm/ 500kHz

4.5.2 Test Setup

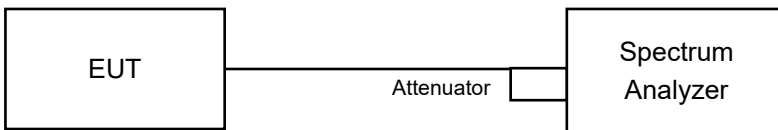

4.5.3 Test Instruments

Refer to section 4.1.2 to get information of above instrument.

4.5.4 Test Procedures

For U-NII-1, U-NII-2A and U-NII-2C band:

Duty cycle of test signal is > 98%

Using method SA-1

- Set span to encompass the entire emission bandwidth (EBW) of the signal.
- Set RBW = 1 MHz, Set VBW ≥ 3 MHz, Detector = RMS
- Sweep time = auto, trigger set to “free run”.
- Trace average at least 100 traces in power averaging mode.
- Record the max value

Duty cycle of test signal is < 98%

Using method SA-2

- Set span to encompass the entire emission bandwidth (EBW) of the signal.
- Set RBW = 1MHz, Set VBW ≥ 3 MHz, Detector = RMS
- Set Channel power measure = 1MHz
- Sweep time = auto, trigger set to “free run”.
- Trace average at least 100 traces in power averaging mode.
- Record the max value and add 10 log (1/duty cycle)

For U-NII-3 band:

Duty cycle of test signal is > 98%

- a. Set span to encompass the entire emission bandwidth (EBW) of the signal.
- b. Set RBW = 300 kHz, Set VBW \geq 1 MHz, Detector = RMS
- c. Use the peak marker function to determine the maximum power level in any 300 kHz band segment within the fundamental EBW.
- d. Scale the observed power level to an equivalent value in 500 kHz by adjusting (increasing) the measured power by a bandwidth correction factor (BWCF) where $BWCF = 10\log(500 \text{ kHz}/300\text{kHz})$
- e. Sweep time = auto, trigger set to "free run".
- f. Trace average at least 100 traces in power averaging mode.
- g. Record the max value

Duty cycle of test signal is < 98%

- a. Set span to encompass the entire emission bandwidth (EBW) of the signal.
- b. Set RBW = 300 kHz, Set VBW \geq 1 MHz, Detector = RMS
- c. Use the peak marker function to determine the maximum power level in any 300 kHz band segment within the fundamental EBW.
- d. Scale the observed power level to an equivalent value in 500 kHz by adjusting (increasing) the measured power by a bandwidth correction factor (BWCF) where $BWCF = 10\log(500 \text{ kHz} / 300 \text{ kHz})$
- e. Sweep time = auto, trigger set to "free run".
- f. Trace average at least 100 traces in power averaging mode.
- g. Record the max value and add $10 \log (1/\text{duty cycle})$

4.5.5 Deviation from Test Standard

No deviation.

4.5.6 EUT Operating Conditions

Same as 4.3.6.

4.5.7 Test Results

For U-NII-1, U-NII-2A and U-NII-2C band:

802.11a

Chan.	Freq. (MHz)	PSD w/o Duty Factor (dBm/MHz)		Duty Factor (dB)	Total PSD with Duty Factor (dBm/MHz)	Max. Limit (dBm/MHz)	Pass / Fail
		Chain 0	Chain 1				
36	5180	-3.31	-1.32	0.54	1.34	9.46	Pass
40	5200	-3.22	-1.34	0.54	1.37	9.46	Pass
48	5240	-3.30	-1.32	0.54	1.35	9.46	Pass
52	5260	0.43	1.69	0.54	4.65	10.60	Pass
60	5300	0.43	2.08	0.54	4.88	10.60	Pass
64	5320	0.27	1.36	0.54	4.39	10.60	Pass
100	5500	1.41	1.28	0.54	4.89	10.47	Pass
116	5580	1.01	0.90	0.54	4.50	10.47	Pass
140	5700	1.44	1.44	0.54	4.99	10.47	Pass
144	5720 (For U-NII-2C)	1.13	1.15	0.54	4.68	10.47	Pass

Note:

- Method E) 2) a) of power density measurement of KDB 662911 is using for calculating total power density. Total power density is summing entire spectra across corresponding frequency bins on the various outputs by computer.
- For U-NII-1 band: Directional gain = $10 \log[(10^{G1/10} + 10^{G2/10} + \dots + 10^{GN/10})/N_{ANT}] = 7.54\text{dBi} > 6\text{dBi}$, so the power density limit shall be reduced to $11-(7.54-6) = 9.46\text{dBm}$.
For U-NII-2A band: Directional gain = $10 \log[(10^{G1/10} + 10^{G2/10} + \dots + 10^{GN/10})/N_{ANT}] = 6.40\text{dBi} > 6\text{dBi}$, so the power density limit shall be reduced to $11-(6.40-6) = 10.60\text{dBm}$.
For U-NII-2C band: Directional gain = $10 \log[(10^{G1/10} + 10^{G2/10} + \dots + 10^{GN/10})/N_{ANT}] = 6.53\text{dBi} > 6\text{dBi}$, so the power density limit shall be reduced to $11-(6.53-6) = 10.47\text{dBm}$.
- Refer to section 3.3 for duty cycle spectrum plot.

802.11ac (VHT20)

Chan.	Freq. (MHz)	PSD w/o Duty Factor (dBm/MHz)		Duty Factor (dB)	Total PSD with Duty Factor (dBm/MHz)	Max. Limit (dBm/MHz)	Pass / Fail
		Chain 0	Chain 1				
36	5180	-3.15	-1.34	0.29	1.15	9.46	Pass
40	5200	-3.12	-1.38	0.29	1.14	9.46	Pass
48	5240	-3.06	-1.14	0.29	1.31	9.46	Pass
52	5260	-0.62	0.70	0.29	3.39	10.60	Pass
60	5300	-0.20	0.80	0.29	3.63	10.60	Pass
64	5320	0.05	0.73	0.29	3.71	10.60	Pass
100	5500	0.52	0.52	0.29	3.82	10.47	Pass
116	5580	0.25	0.22	0.29	3.54	10.47	Pass
140	5700	0.72	0.62	0.29	3.97	10.47	Pass
144	5720 (For U-NII-2C)	0.36	0.37	0.29	3.67	10.47	Pass

Note:

- Method E) 2) a) of power density measurement of KDB 662911 is using for calculating total power density. Total power density is summing entire spectra across corresponding frequency bins on the various outputs by computer.
- For U-NII-1 band: Directional gain = $10 \log[(10^{G1/10} + 10^{G2/10} + \dots + 10^{GN/10})/N_{ANT}] = 7.54\text{dBi} > 6\text{dBi}$, so the power density limit shall be reduced to $11-(7.54-6) = 9.46\text{dBm}$.
For U-NII-2A band: Directional gain = $10 \log[(10^{G1/10} + 10^{G2/10} + \dots + 10^{GN/10})/N_{ANT}] = 6.40\text{dBi} > 6\text{dBi}$, so the power density limit shall be reduced to $11-(6.40-6) = 10.60\text{dBm}$.
For U-NII-2C band: Directional gain = $10 \log[(10^{G1/10} + 10^{G2/10} + \dots + 10^{GN/10})/N_{ANT}] = 6.53\text{dBi} > 6\text{dBi}$, so the power density limit shall be reduced to $11-(6.53-6) = 10.47\text{dBm}$.
- Refer to section 3.3 for duty cycle spectrum plot.

802.11ac (VHT40)

Chan.	Freq. (MHz)	PSD w/o Duty Factor (dBm/MHz)		Duty Factor (dB)	Total PSD with Duty Factor (dBm/MHz)	Max. Limit (dBm/MHz)	Pass / Fail
		Chain 0	Chain 1				
38	5190	-4.34	-3.17	0.89	0.19	9.46	Pass
46	5230	-4.07	-2.87	0.89	0.48	9.46	Pass
54	5270	-4.10	-3.12	0.89	0.32	10.60	Pass
62	5310	-4.50	-3.17	0.89	0.12	10.60	Pass
102	5510	-3.87	-3.56	0.89	0.19	10.47	Pass
110	5550	-3.63	-3.58	0.89	0.30	10.47	Pass
134	5670	-3.62	-3.40	0.89	0.40	10.47	Pass
142	5710 (For U-NII-2C)	-4.22	-3.25	0.89	0.20	10.47	Pass

Note:

- Method E) 2) a) of power density measurement of KDB 662911 is using for calculating total power density. Total power density is summing entire spectra across corresponding frequency bins on the various outputs by computer.
- For U-NII-1 band: Directional gain = $10 \log[(10^{G1/10} + 10^{G2/10} + \dots + 10^{GN/10})/N_{ANT}] = 7.54\text{dBi} > 6\text{dBi}$, so the power density limit shall be reduced to $11-(7.54-6) = 9.46\text{dBm}$.
For U-NII-2A band: Directional gain = $10 \log[(10^{G1/10} + 10^{G2/10} + \dots + 10^{GN/10})/N_{ANT}] = 6.40\text{dBi} > 6\text{dBi}$, so the power density limit shall be reduced to $11-(6.40-6) = 10.60\text{dBm}$.
For U-NII-2C band: Directional gain = $10 \log[(10^{G1/10} + 10^{G2/10} + \dots + 10^{GN/10})/N_{ANT}] = 6.53\text{dBi} > 6\text{dBi}$, so the power density limit shall be reduced to $11-(6.53-6) = 10.47\text{dBm}$.
- Refer to section 3.3 for duty cycle spectrum plot.

802.11ac (VHT80)

Chan.	Freq. (MHz)	PSD w/o Duty Factor (dBm/MHz)		Duty Factor (dB)	Total PSD with Duty Factor (dBm/MHz)	Max. Limit (dBm/MHz)	Pass / Fail
		Chain 0	Chain 1				
42	5210	-7.08	-5.95	0.90	-2.56	9.46	Pass
58	5290	-6.78	-6.41	0.90	-2.68	10.60	Pass
106	5530	-6.49	-6.64	0.90	-2.65	10.47	Pass
122	5610	-6.49	-6.45	0.90	-2.56	10.47	Pass
138	5690 (For U-NII-2C)	-7.12	-6.60	0.90	-2.94	10.47	Pass

Note:

- Method E) 2) a) of power density measurement of KDB 662911 is using for calculating total power density. Total power density is summing entire spectra across corresponding frequency bins on the various outputs by computer.
- For U-NII-1 band: Directional gain = $10 \log[(10^{G1/10} + 10^{G2/10} + \dots + 10^{GN/10})/N_{ANT}] = 7.54\text{dBi} > 6\text{dBi}$, so the power density limit shall be reduced to $11-(7.54-6) = 9.46\text{dBm}$.
For U-NII-2A band: Directional gain = $10 \log[(10^{G1/10} + 10^{G2/10} + \dots + 10^{GN/10})/N_{ANT}] = 6.40\text{dBi} > 6\text{dBi}$, so the power density limit shall be reduced to $11-(6.40-6) = 10.60\text{dBm}$.
For U-NII-2C band: Directional gain = $10 \log[(10^{G1/10} + 10^{G2/10} + \dots + 10^{GN/10})/N_{ANT}] = 6.53\text{dBi} > 6\text{dBi}$, so the power density limit shall be reduced to $11-(6.53-6) = 10.47\text{dBm}$.
- Refer to section 3.3 for duty cycle spectrum plot.

Spectrum Plot of Worst Value

802.11a / Chain 1 / CH 60

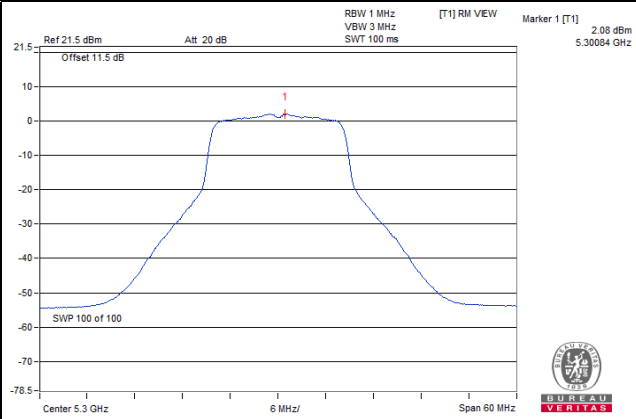

802.11ac (VHT20) / Chain 1 / CH 60

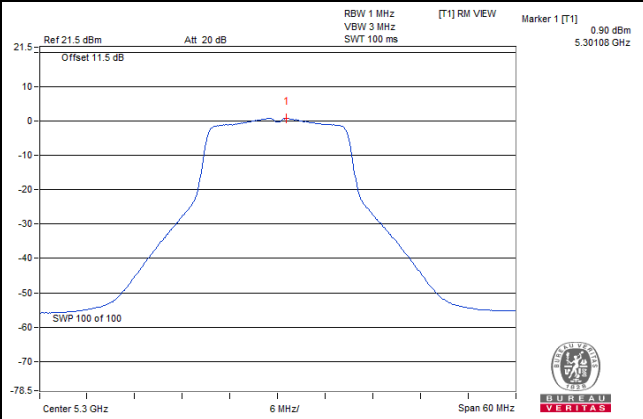

802.11ac (VHT40) / Chain 1 / CH 46

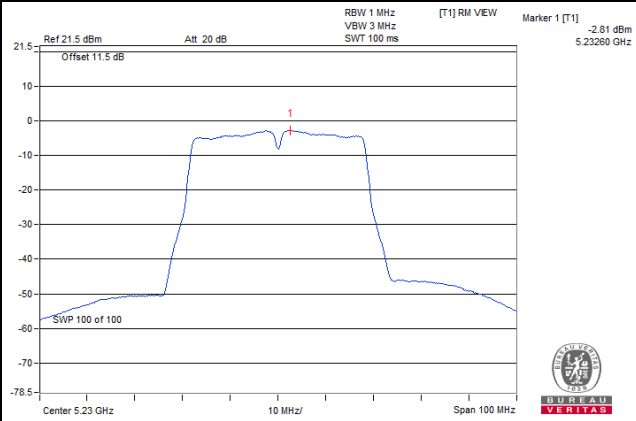

802.11ac (VHT80) / Chain 1 / CH 42

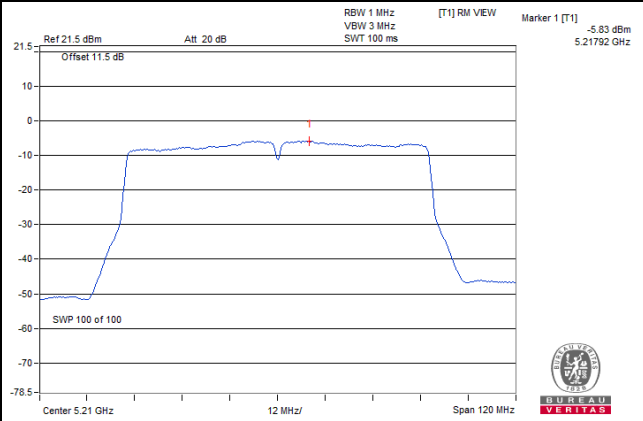

For U-NII-3 band:

802.11a

TX chain	Chan.	Freq. (MHz)	PSD W/O Duty Factor		10 log (N=2) dB	Duty Factor (dB)	Total PSD With Duty Factor (dBm/500kHz)	Limit (dBm/500kHz)	Pass / Fail
			(dBm/300kHz)	(dBm/500kHz)					
0	144	5720 (For U-NII-3)	-5.41	-3.19	3.01	0.54	0.36	29.27	Pass
	149	5745	-1.64	0.58	3.01	0.54	4.13	29.27	Pass
	157	5785	-2.88	-0.66	3.01	0.54	2.89	29.27	Pass
	165	5825	-1.89	0.33	3.01	0.54	3.88	29.27	Pass
1	144	5720 (For U-NII-3)	-5.29	-3.07	3.01	0.54	0.48	29.27	Pass
	149	5745	-1.57	0.65	3.01	0.54	4.20	29.27	Pass
	157	5785	-0.56	1.66	3.01	0.54	5.21	29.27	Pass
	165	5825	-0.90	1.32	3.01	0.54	4.87	29.27	Pass

Note:

1. Method E) 2) c) of power density measurement of KDB 662911 is using for calculating total power density.
2. Directional gain = $10 \log[(10^{G1/10} + 10^{G2/10} + \dots + 10^{GN/10})/N_{ANT}] = 6.73\text{dBi} > 6\text{dBi}$, so the power density limit shall be reduced to $30-(6.73-6) = 29.27\text{dBm}$.
3. Refer to section 3.3 for duty cycle spectrum plot.

802.11ac (VHT20)

TX chain	Chan.	Freq. (MHz)	PSD W/O Duty Factor		10 log (N=2) dB	Duty Factor (dB)	Total PSD With Duty Factor (dBm/500kHz)	Limit (dBm/500kHz)	Pass / Fail
			(dBm/300kHz)	(dBm/500kHz)					
0	144	5720 (For U-NII-3)	-5.72	-3.50	3.01	0.29	-0.20	29.27	Pass
	149	5745	-3.62	-1.40	3.01	0.29	1.90	29.27	Pass
	157	5785	-3.95	-1.73	3.01	0.29	1.57	29.27	Pass
	165	5825	-3.03	-0.81	3.01	0.29	2.49	29.27	Pass
1	144	5720 (For U-NII-3)	-5.71	-3.49	3.01	0.29	-0.19	29.27	Pass
	149	5745	-2.12	0.10	3.01	0.29	3.40	29.27	Pass
	157	5785	-1.61	0.61	3.01	0.29	3.91	29.27	Pass
	165	5825	-1.91	0.31	3.01	0.29	3.61	29.27	Pass

Note:

1. Method E) 2) c) of power density measurement of KDB 662911 is using for calculating total power density.
2. Directional gain = $10 \log[(10^{G1/10} + 10^{G2/10} + \dots + 10^{GN/10})/N_{ANT}] = 6.73\text{dBi} > 6\text{dBi}$, so the power density limit shall be reduced to $30-(6.73-6) = 29.27\text{dBm}$.
3. Refer to section 3.3 for duty cycle spectrum plot.

802.11ac (VHT40)

TX chain	Chan.	Freq. (MHz)	PSD W/O Duty Factor		10 log (N=2) dB	Duty Factor (dB)	Total PSD With Duty Factor (dBm/500kHz)	Limit (dBm/500kHz)	Pass / Fail
			(dBm/300kHz)	(dBm/500kHz)					
0	142	5710 (For U-NII-3)	-11.41	-9.19	3.01	0.89	-5.29	29.27	Pass
	151	5755	-6.46	-4.24	3.01	0.89	-0.34	29.27	Pass
	159	5795	-7.74	-5.52	3.01	0.89	-1.62	29.27	Pass
1	142	5710 (For U-NII-3)	-10.18	-7.96	3.01	0.89	-4.06	29.27	Pass
	151	5755	-7.16	-4.94	3.01	0.89	-1.04	29.27	Pass
	159	5795	-5.79	-3.57	3.01	0.89	0.33	29.27	Pass

Note:

1. Method E) 2) c) of power density measurement of KDB 662911 is using for calculating total power density.
2. Directional gain = $10 \log[(10^{G1/10} + 10^{G2/10} + \dots + 10^{GN/10})/N_{ANT}] = 6.73\text{dBi} > 6\text{dBi}$, so the power density limit shall be reduced to $30-(6.73-6) = 29.27\text{dBm}$.
3. Refer to section 3.3 for duty cycle spectrum plot.

802.11ac (VHT80)

TX chain	Chan.	Freq. (MHz)	PSD W/O Duty Factor		10 log (N=2) dB	Duty Factor (dB)	Total PSD With Duty Factor (dBm/500kHz)	Limit (dBm/500kHz)	Pass / Fail
			(dBm/300kHz)	(dBm/500kHz)					
0	138	5690 (For U-NII-3)	-14.13	-11.91	3.01	0.90	-8.00	29.27	Pass
	155	5775	-10.46	-8.24	3.01	0.90	-4.33	29.27	Pass
1	138	5690 (For U-NII-3)	-13.53	-11.31	3.01	0.90	-7.40	29.27	Pass
	155	5775	-8.50	-6.28	3.01	0.90	-2.37	29.27	Pass

Note:

1. Method E) 2) c) of power density measurement of KDB 662911 is using for calculating total power density.
2. Directional gain = $10 \log[(10^{G1/10} + 10^{G2/10} + \dots + 10^{GN/10})/N_{ANT}] = 6.73\text{dBi} > 6\text{dBi}$, so the power density limit shall be reduced to $30-(6.73-6) = 29.27\text{dBm}$.
3. Refer to section 3.3 for duty cycle spectrum plot.

Spectrum Plot of Worst Value

802.11a

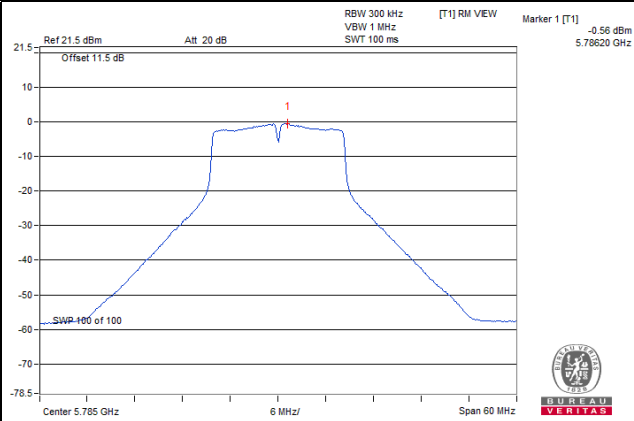

802.11ac (VHT20)

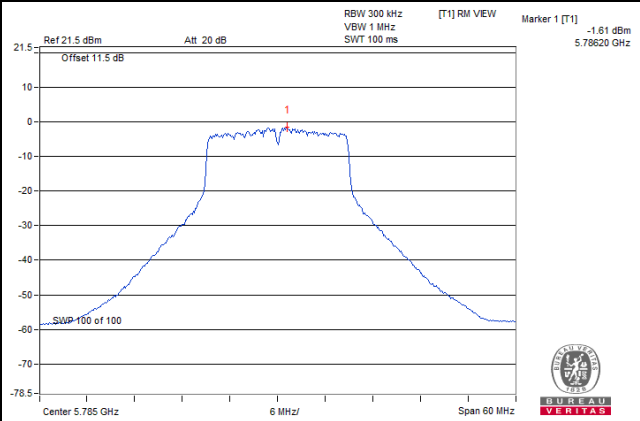

802.11ac (VHT40)

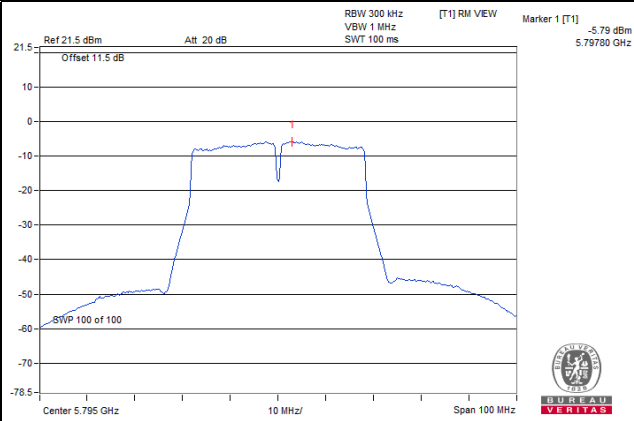

802.11ac (VHT80)

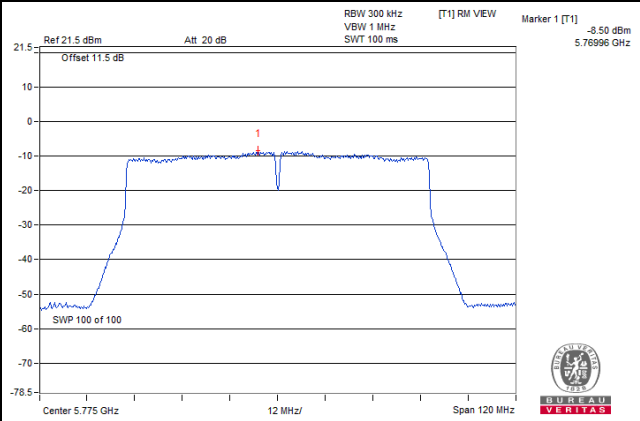

4.6 Frequency Stability

4.6.1 Limits of Frequency Stability Measurement

The frequency of the carrier signal shall be maintained within band of operation

4.6.2 Test Setup

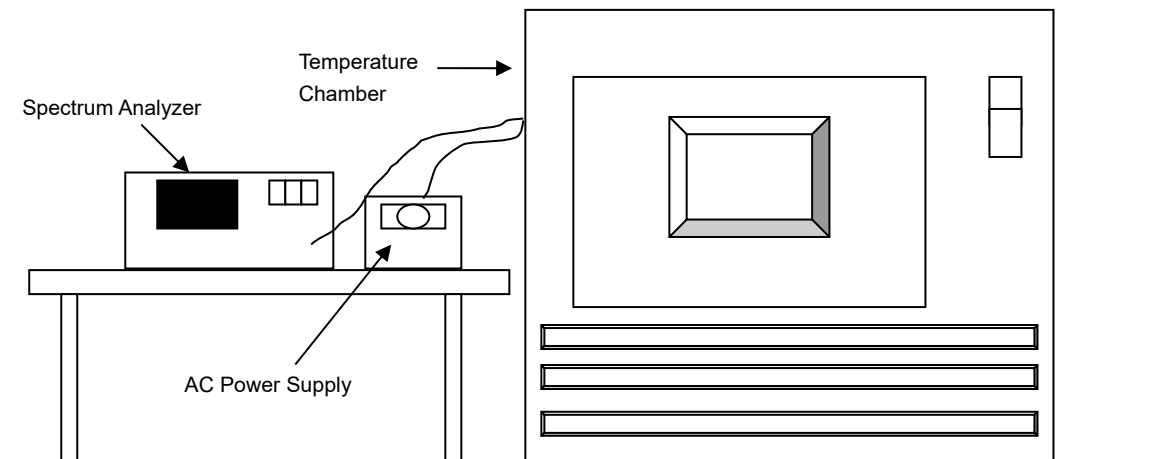

4.6.3 Test Instruments

Description & Manufacturer	Model No.	Serial No.	Cal. Date	Cal. Due
Spectrum Analyzer ROHDE & SCHWARZ	FSP40	100269	Jun. 09, 2020	Jun. 08, 2021
Standard Temperature And Humidity Chamber GIANT FORCE	GTH-120-40-CP-AR	MAA1306-019	Sep. 09, 2020	Sep. 08, 2021
Digital Multimeter Fluke	87-III	70360742	Jun. 23, 2020	Jun. 22, 2021
DC Power Supply Topward	6306A	727263	NA	NA

Note: 1. The calibration interval of the above test instruments is 12 months and the calibrations are traceable to NML/ROC and NIST/USA.

4.6.4 Test Procedure

- The EUT was placed inside the environmental test chamber and powered by nominal AC voltage.
- Turn the EUT on and couple its output to a spectrum analyzer.
- Turn the EUT off and set the chamber to the highest temperature specified.
- Allow sufficient time (approximately 30 min) for the temperature of the chamber to stabilize, turn the EUT on and measure the operating frequency after 2, 5, and 10 minutes.
- Repeat step 2 and 3 with the temperature chamber set to the lowest temperature.
- The test chamber was allowed to stabilize at +20 degree C for a minimum of 30 minutes. The supply voltage was then adjusted on the EUT from 85% to 115% and the frequency record.

4.6.5 Deviation from Test Standard

No deviation.

4.6.6 EUT Operating Condition

Set the EUT transmit at un-modulation mode to test frequency stability.

4.6.7 Test Results

Frequency Stability Versus Temp.									
Operating Frequency: 5180MHz									
Temp. (°C)	Power Supply (Vdc)	0 Minute		2 Minute		5 Minute		10 Minute	
		Measured Frequency (MHz)	Result	Measured Frequency (MHz)	Result	Measured Frequency (MHz)	Result	Measured Frequency (MHz)	Result
50	3.85	5179.9934	PASS	5179.9978	PASS	5179.9945	PASS	5179.9938	PASS
40	3.85	5180.0047	PASS	5180.0086	PASS	5180.0079	PASS	5180.0078	PASS
30	3.85	5179.9845	PASS	5179.9872	PASS	5179.9836	PASS	5179.9822	PASS
20	3.85	5179.9864	PASS	5179.9882	PASS	5179.9869	PASS	5179.9916	PASS
10	3.85	5179.9979	PASS	5179.9967	PASS	5179.9977	PASS	5179.9962	PASS
0	3.85	5180.0183	PASS	5180.0205	PASS	5180.0166	PASS	5180.0201	PASS
-10	3.85	5180.0092	PASS	5180.0077	PASS	5180.0083	PASS	5180.0087	PASS

Frequency Stability Versus Voltage									
Operating Frequency: 5180MHz									
Temp. (°C)	Power Supply (Vdc)	0 Minute		2 Minute		5 Minute		10 Minute	
		Measured Frequency (MHz)	Result	Measured Frequency (MHz)	Result	Measured Frequency (MHz)	Result	Measured Frequency (MHz)	Result
20	4.4275	5179.9861	PASS	5179.9888	PASS	5179.9864	PASS	5179.9922	PASS
	3.85	5179.9864	PASS	5179.9882	PASS	5179.9869	PASS	5179.9916	PASS
	3.2725	5179.9863	PASS	5179.9877	PASS	5179.9878	PASS	5179.9926	PASS

4.7 6dB Bandwidth Measurement

4.7.1 Limits of 6dB Bandwidth Measurement

The minimum of 6dB Bandwidth Measurement is 0.5MHz.

4.7.2 Test Setup

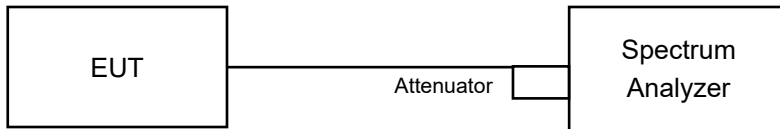

4.7.3 Test Instruments

Refer to section 4.1.2 to get information of above instrument.

4.7.4 Test Procedure

- Set resolution bandwidth (RBW) = 100kHz
- Set the video bandwidth (VBW) $\geq 3 \times$ RBW, Detector = Peak.
- Trace mode = max hold.
- Sweep = auto couple.
- Measure the maximum width of the emission that is constrained by the frequencies associated with the two amplitude points (upper and lower) that are attenuated by 6 dB relative to the maximum level measured in the fundamental emission

4.7.5 Deviation from Test Standard

No deviation.

4.7.6 EUT Operating Condition

The software provided by client to enable the EUT under transmission condition continuously at lowest, middle and highest channel frequencies individually.

4.7.7 Test Results

802.11a

Channel	Frequency (MHz)	6dB Bandwidth (MHz)		Minimum Limit (MHz)	Pass / Fail
		Chain 0	Chain 1		
144	5720 (For U-NII-3)	3.15	2.92	0.5	Pass
149	5745	16.08	16.32	0.5	Pass
157	5785	16.36	16.33	0.5	Pass
165	5825	15.39	16.32	0.5	Pass

802.11ac (VHT20)

Channel	Frequency (MHz)	6dB Bandwidth (MHz)		Minimum Limit (MHz)	Pass / Fail
		Chain 0	Chain 1		
144	5720 (For U-NII-3)	3.16	3.15	0.5	Pass
149	5745	16.07	16.58	0.5	Pass
157	5785	15.16	16.81	0.5	Pass
165	5825	15.37	16.57	0.5	Pass

802.11ac (VHT40)

Channel	Frequency (MHz)	6dB Bandwidth (MHz)		Minimum Limit (MHz)	Pass / Fail
		Chain 0	Chain 1		
142	5710 (For U-NII-3)	2.92	2.90	0.5	Pass
151	5755	36.12	36.15	0.5	Pass
159	5795	35.82	35.88	0.5	Pass

802.11ac (VHT80)

Channel	Frequency (MHz)	6dB Bandwidth (MHz)		Minimum Limit (MHz)	Pass / Fail
		Chain 0	Chain 1		
138	5690 (For U-NII-3)	2.74	2.74	0.5	Pass
155	5775	75.43	75.47	0.5	Pass

Spectrum Plot of Worst Value

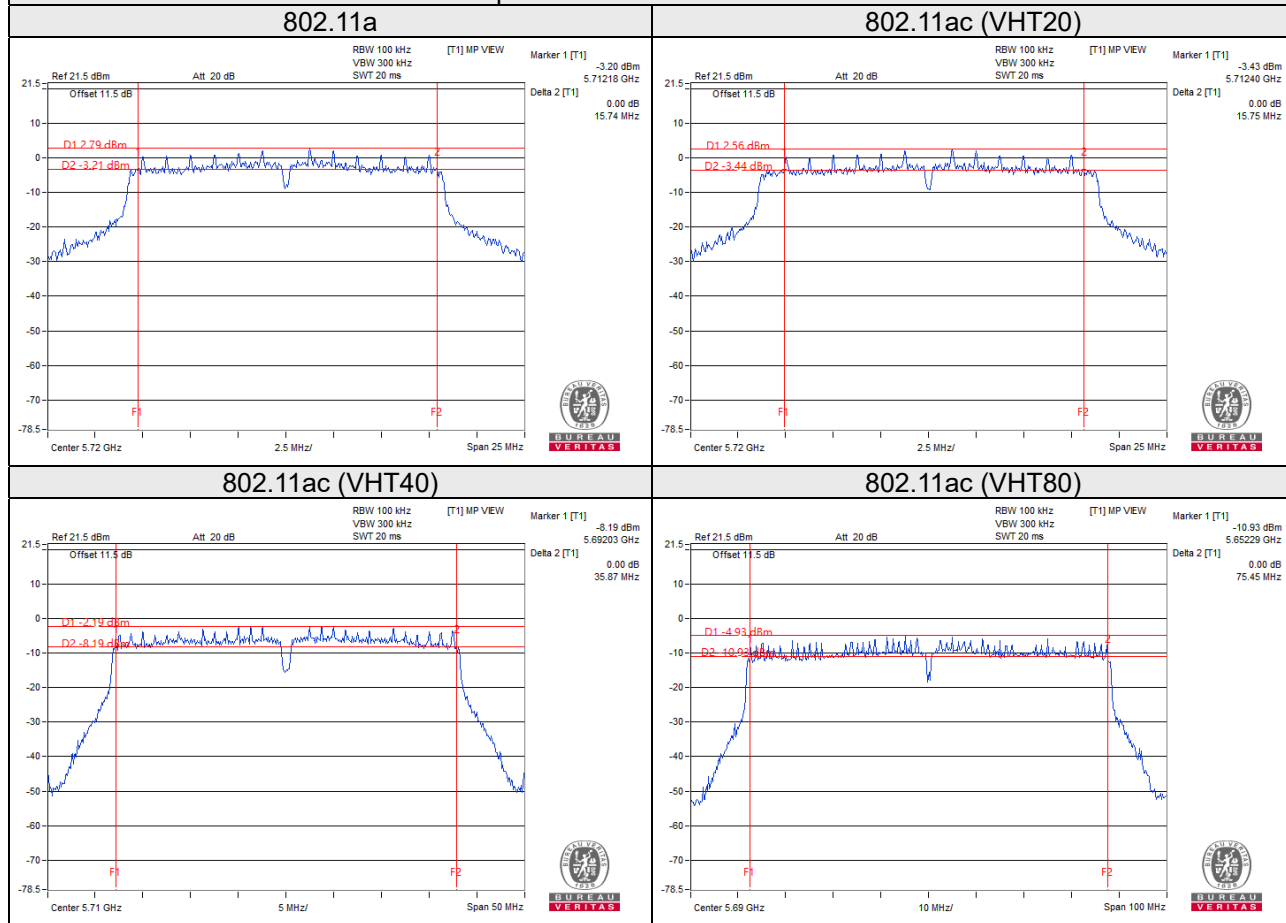

Note:

For CH144 (UNII-3 Band): The 6dB bandwidth above 5725MHz = Marker 1 + Delta 2 - 5725MHz

For CH142 (UNII-3 Band): The 6dB bandwidth above 5725MHz = Marker 1 + Delta 2 - 5725MHz

For CH138 (UNII-3 Band): The 6dB bandwidth above 5725MHz = Marker 1 + Delta 2 - 5725MHz

5 Pictures of Test Arrangements

Please refer to the attached file (Test Setup Photo).

Annex A- Radiated out of Band Emission (OOBE) Measurement (For U-NII-3 band)

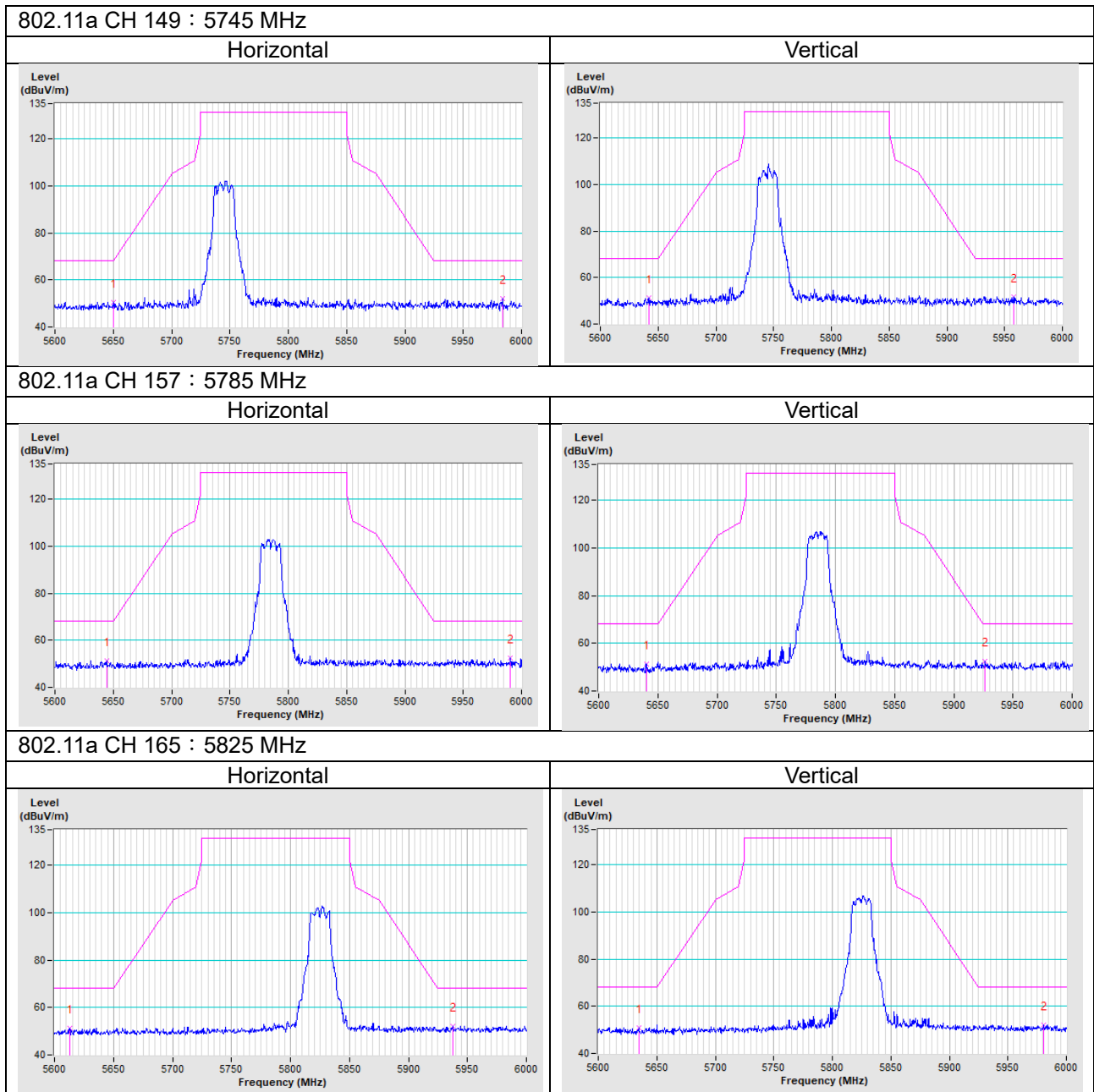

802.11ac (VHT20) CH 149 : 5745 MHz

Horizontal

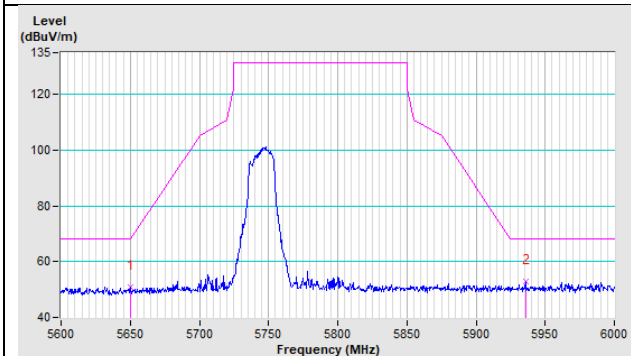

Vertical

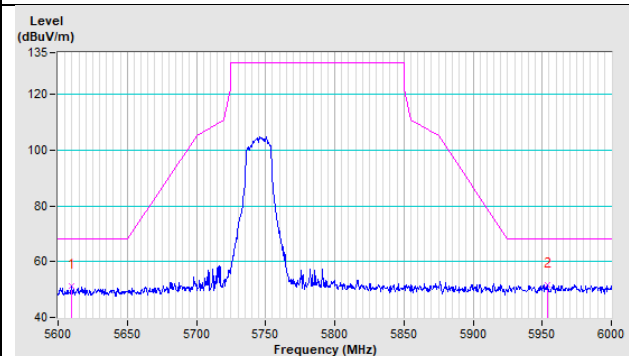

802.11ac (VHT20) CH 157 : 5785 MHz

Horizontal

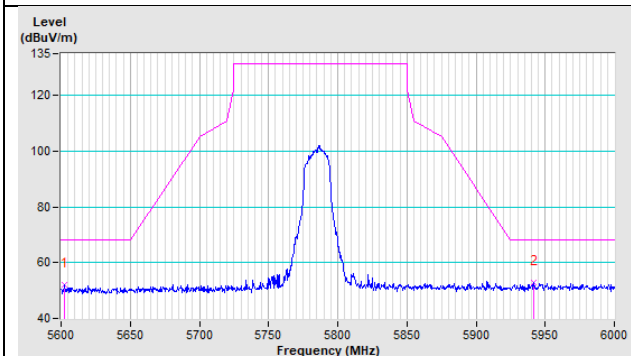

Vertical

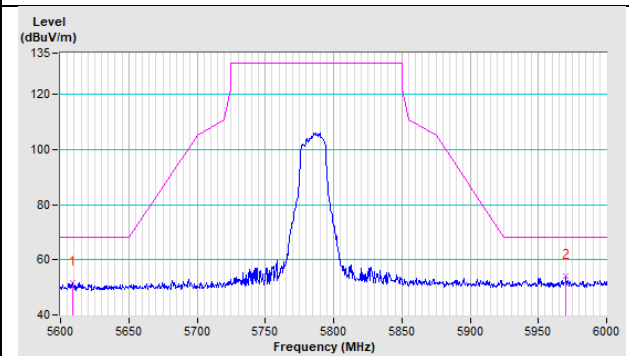

802.11ac (VHT20) CH 165 : 5825 MHz

Horizontal

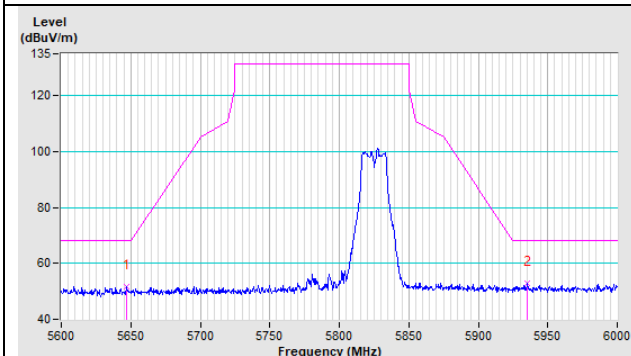

Vertical

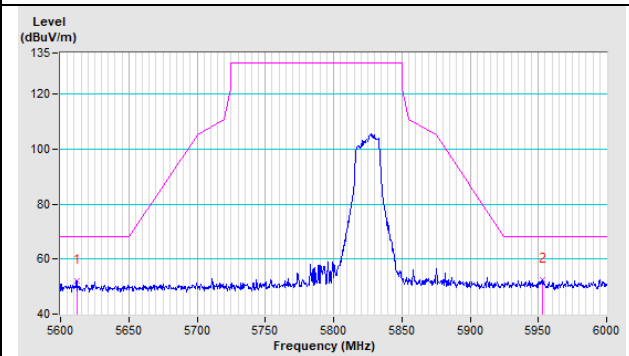

802.11ac (VHT40) CH 151 : 5755 MHz

Horizontal

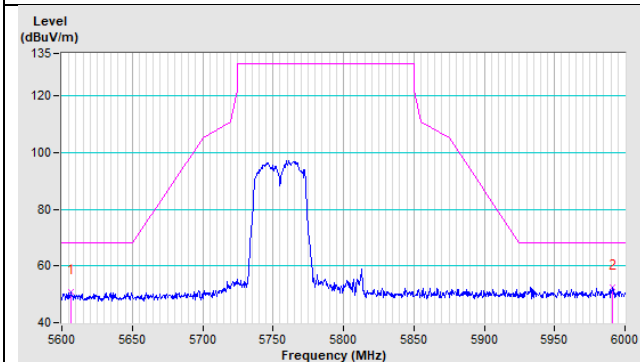

Vertical

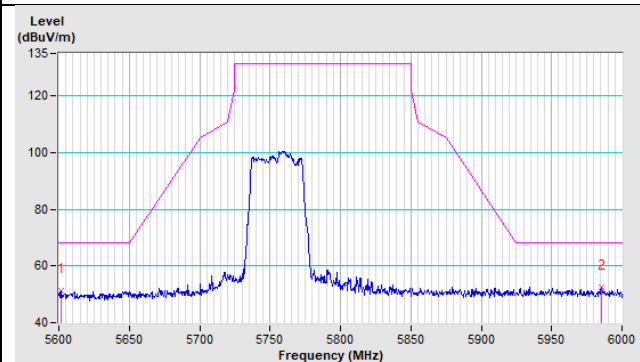

802.11ac (VHT40) CH 159 : 5795 MHz

Horizontal

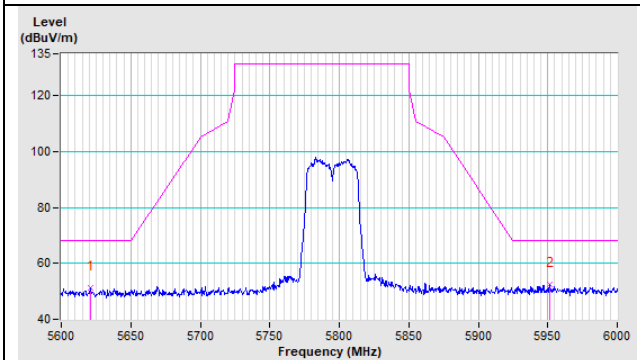

Vertical

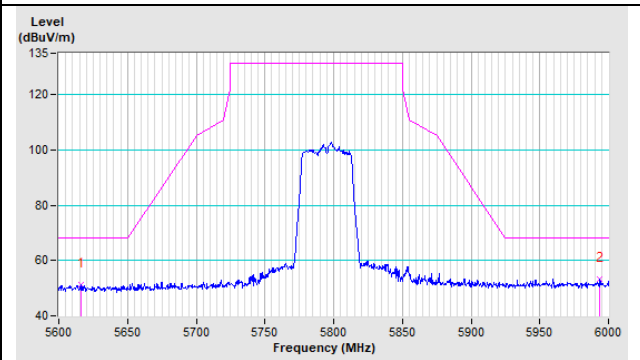

802.11ac (VHT80) CH 155 : 5775 MHz

Horizontal

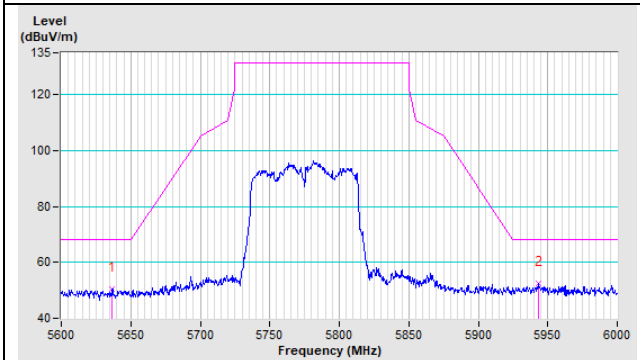

Vertical

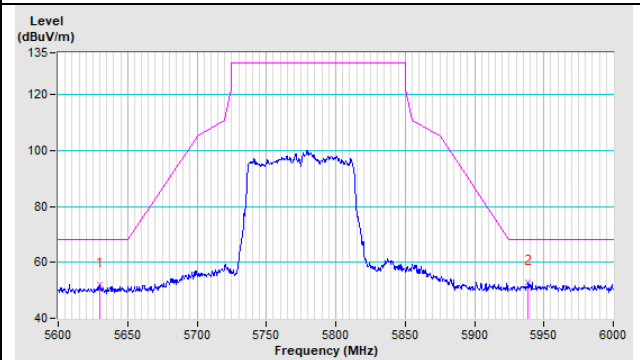

Annex B- Band Edge Measurement

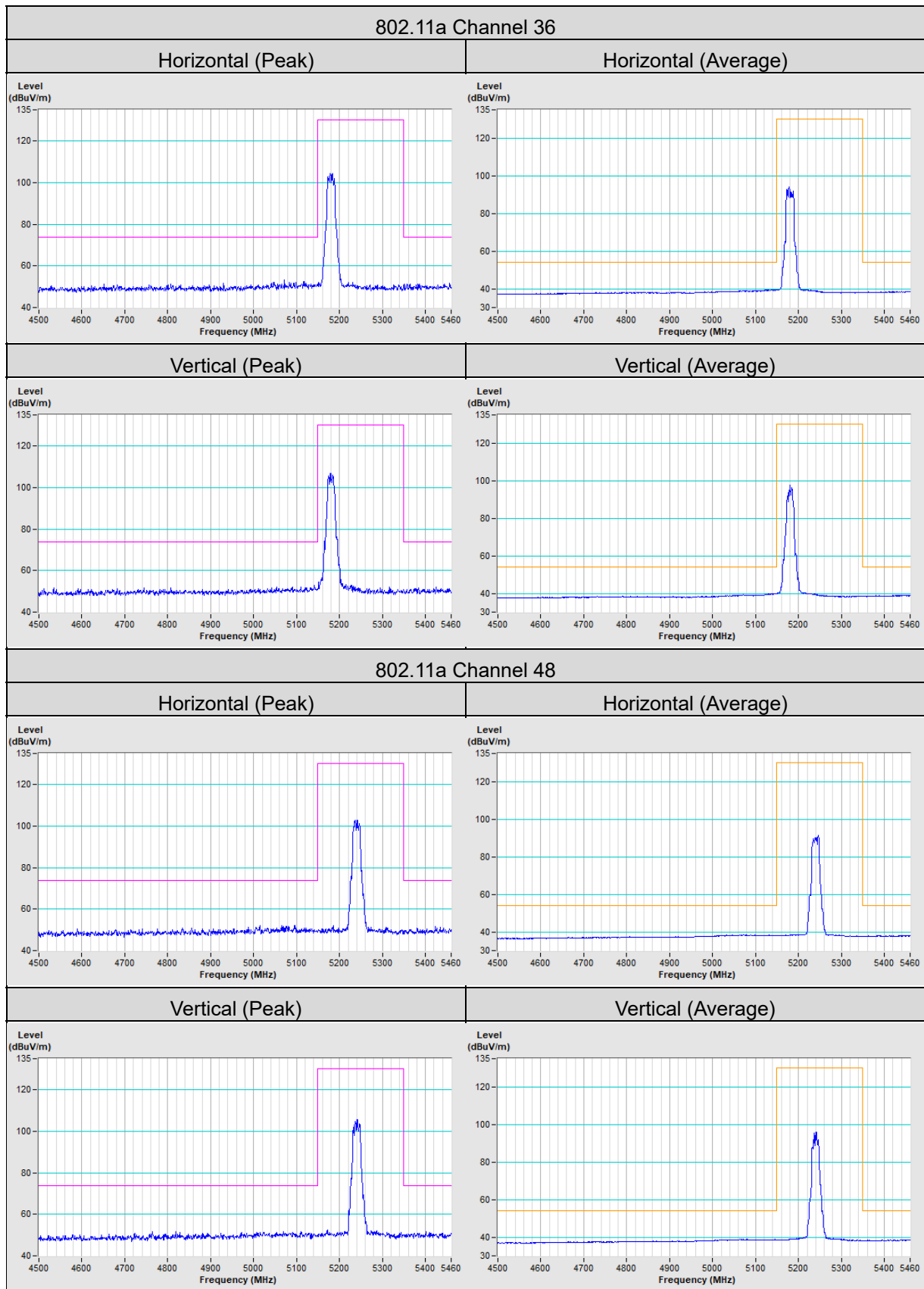

802.11a Channel 52

Horizontal (Peak)

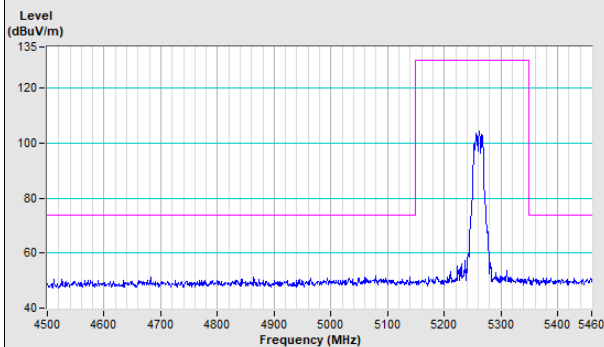

Horizontal (Average)

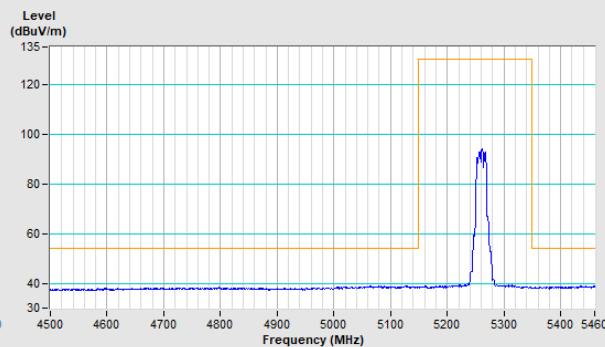

Vertical (Peak)

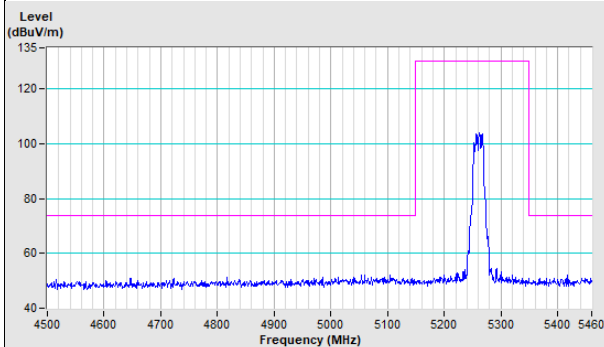

Vertical (Average)

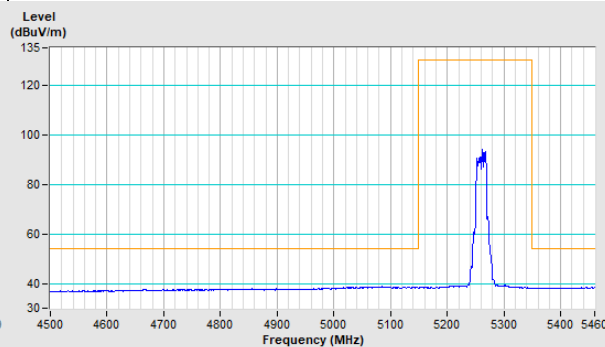

802.11a Channel 64

Horizontal (Peak)

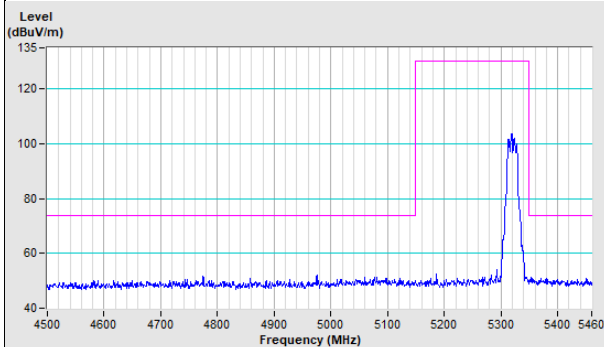

Horizontal (Average)

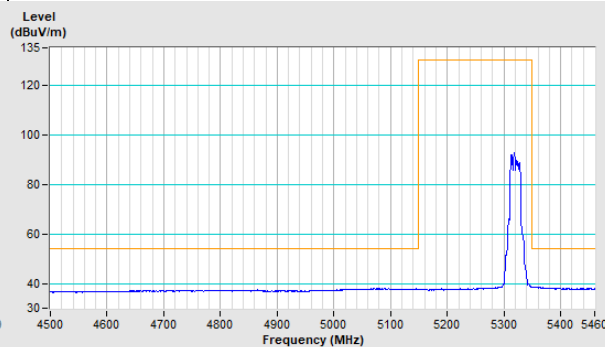

Vertical (Peak)

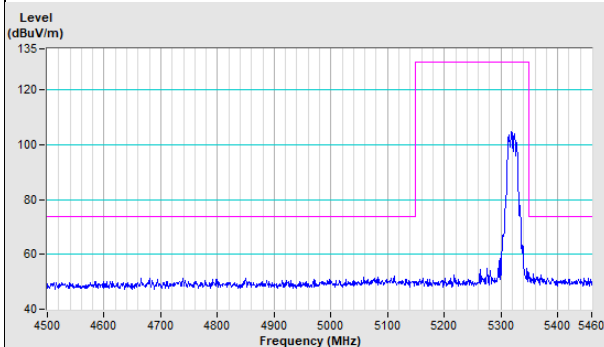

Vertical (Average)

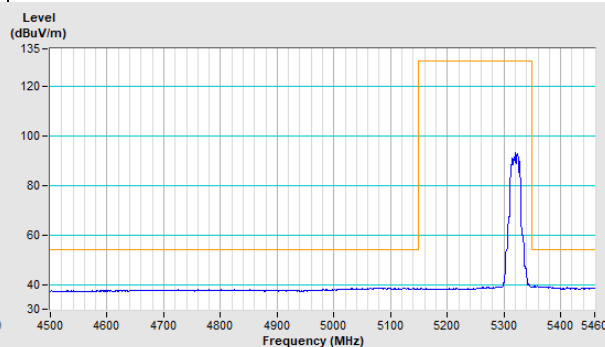

802.11a Channel 100

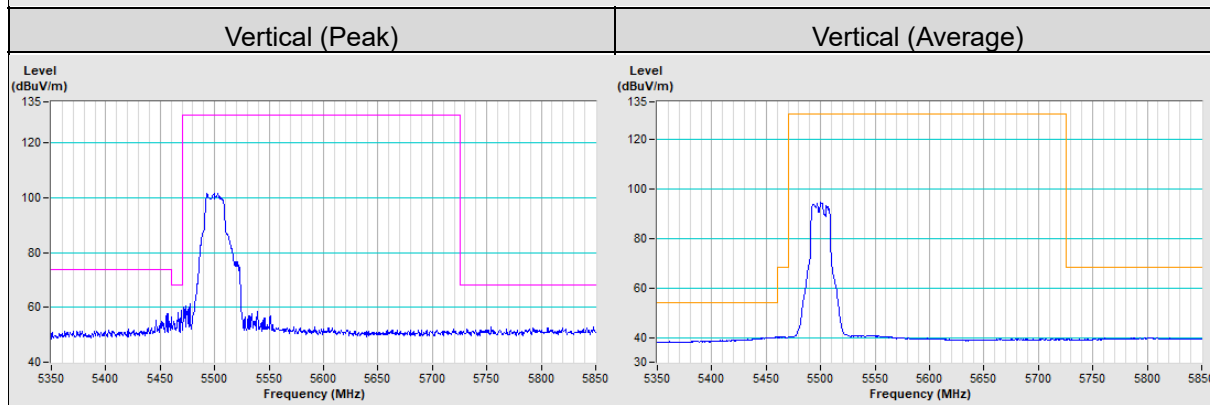
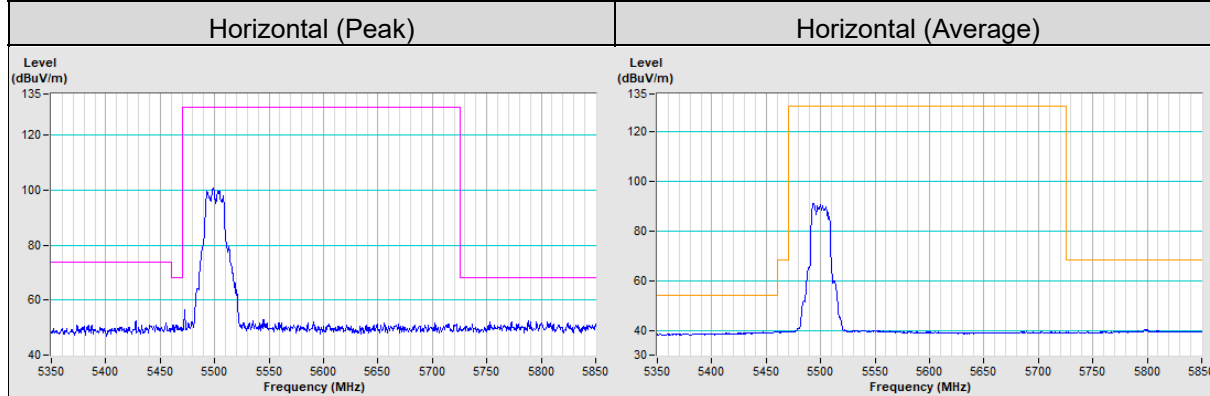

802.11a Channel 140

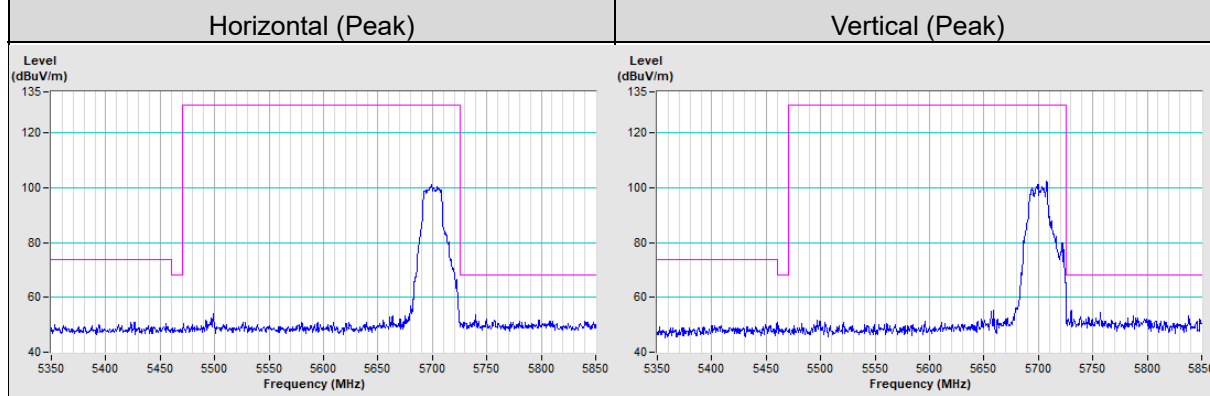

802.11a Channel 144

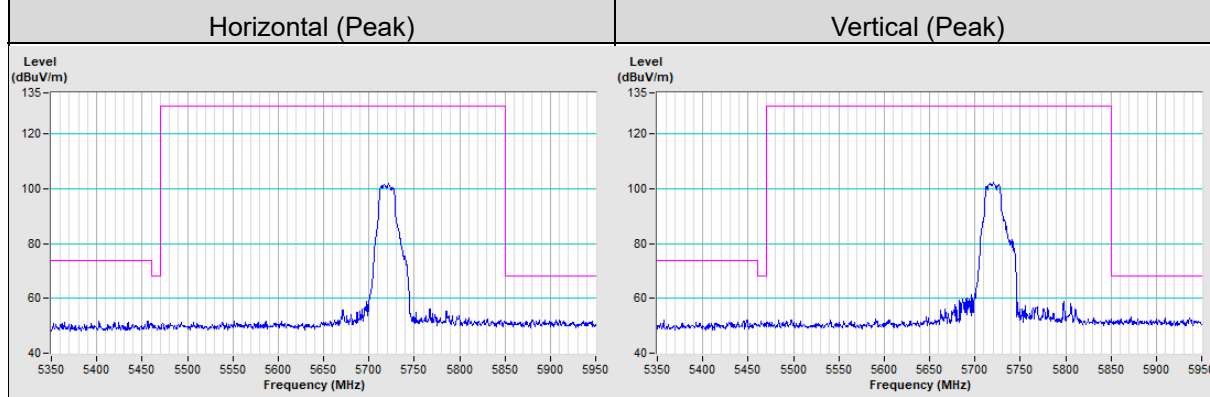

802.11ac (VHT20) Channel 36

Horizontal (Peak)	Horizontal (Average)
--------------------------	-----------------------------

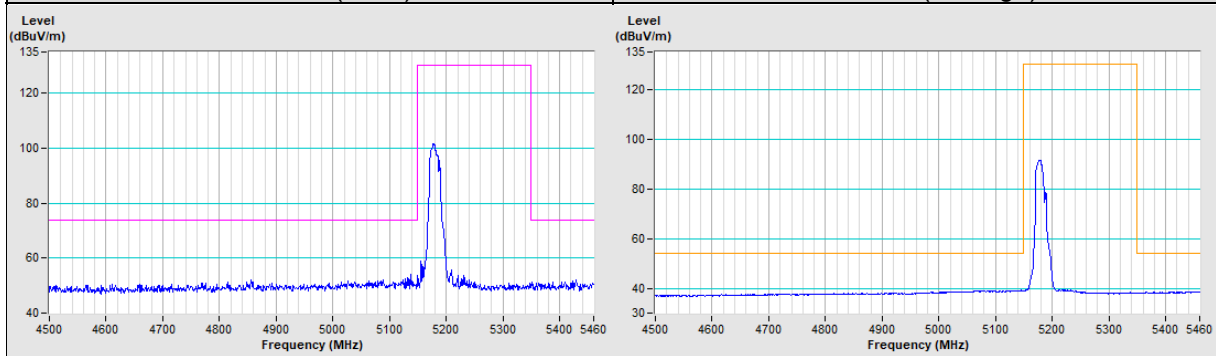

Vertical (Peak)	Vertical (Average)
------------------------	---------------------------

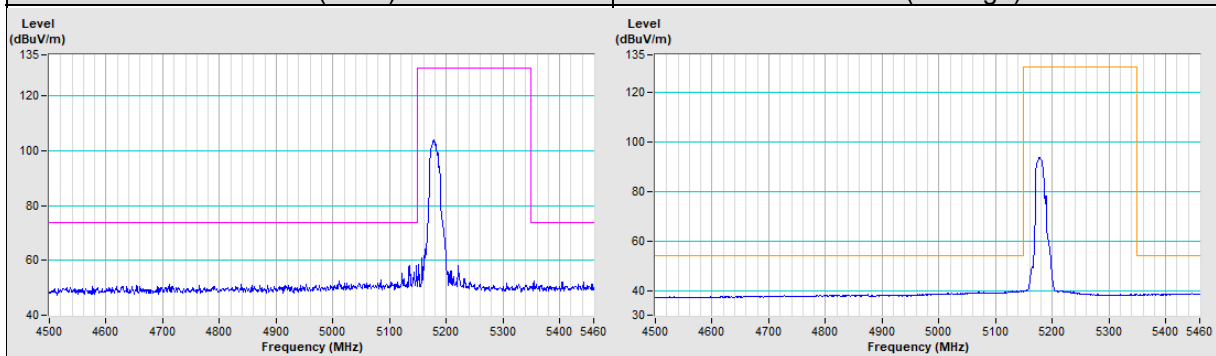

802.11ac (VHT20) Channel 48

Horizontal (Peak)	Horizontal (Average)
--------------------------	-----------------------------

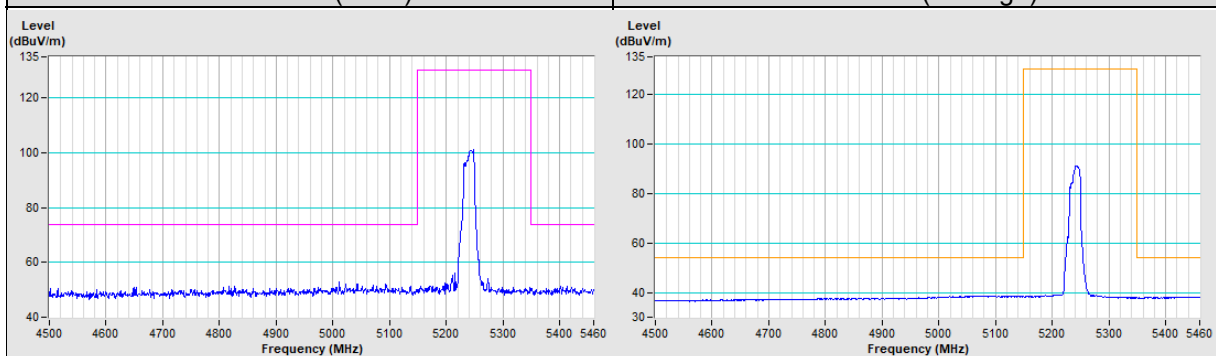

Vertical (Peak)	Vertical (Average)
------------------------	---------------------------

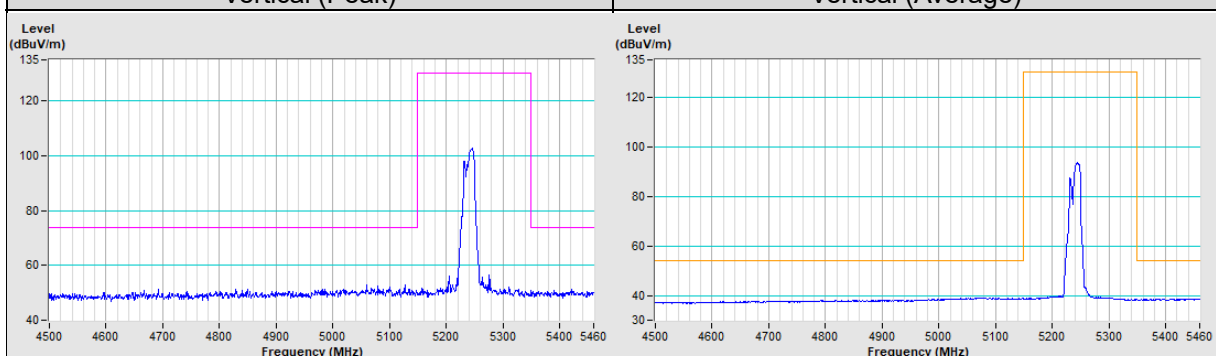

802.11ac (VHT20) Channel 52

Horizontal (Peak)	Horizontal (Average)
-------------------	----------------------

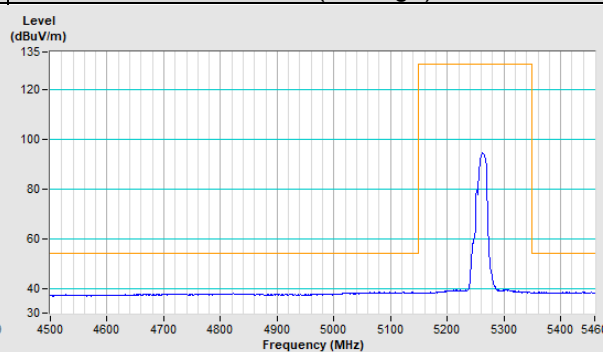
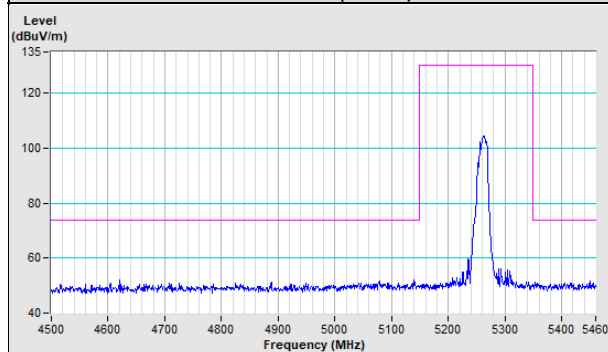

Vertical (Peak)	Vertical (Average)
-----------------	--------------------

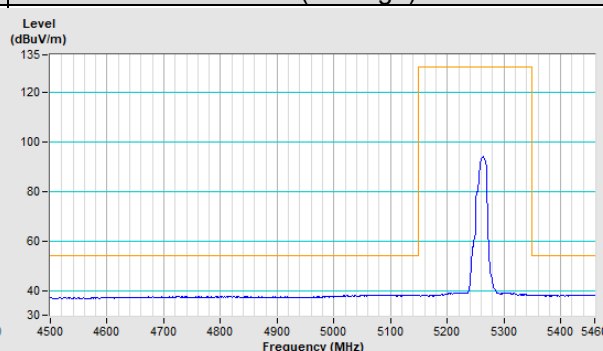
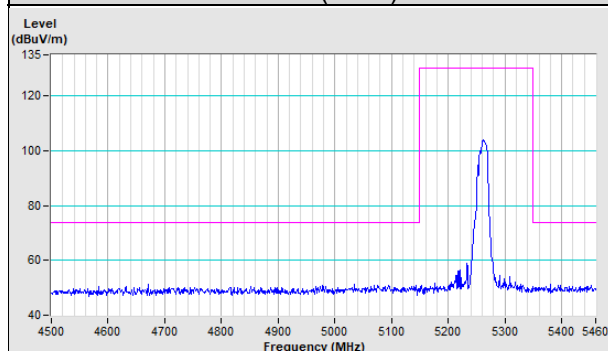

802.11ac (VHT20) Channel 64

Horizontal (Peak)	Horizontal (Average)
-------------------	----------------------

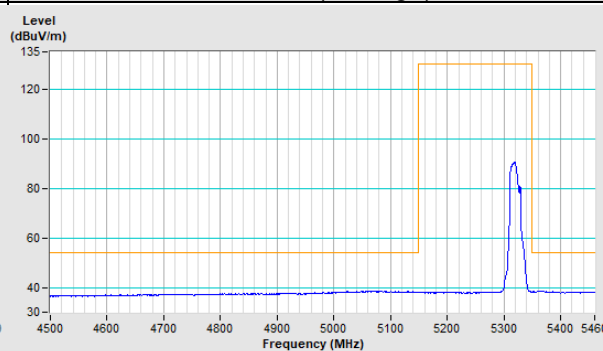
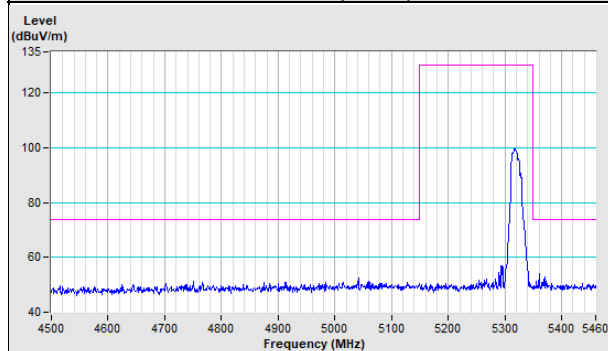

Vertical (Peak)	Vertical (Average)
-----------------	--------------------

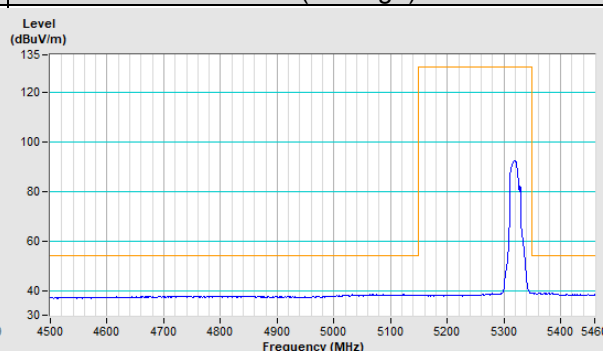
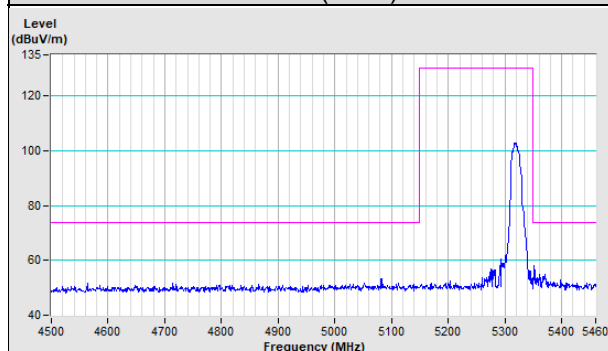

802.11ac (VHT20) Channel 100

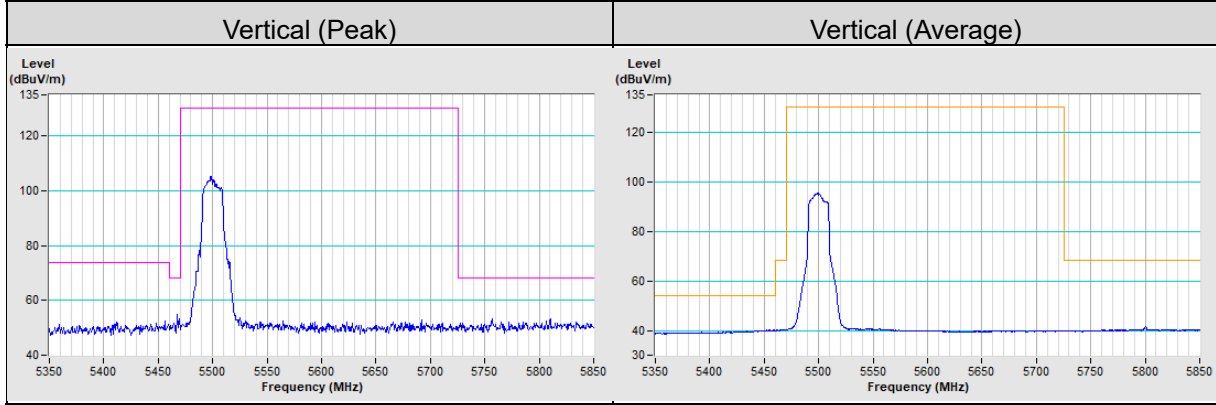
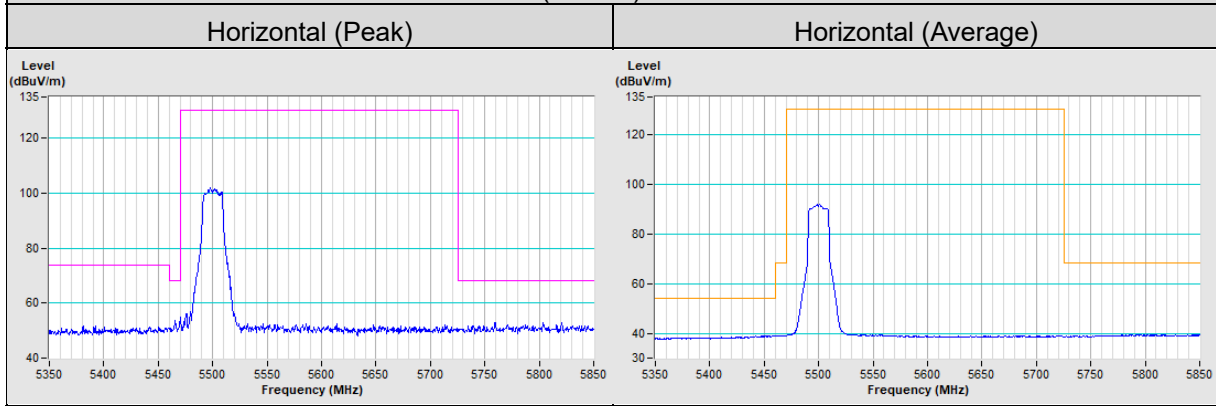

802.11ac (VHT20) Channel 140

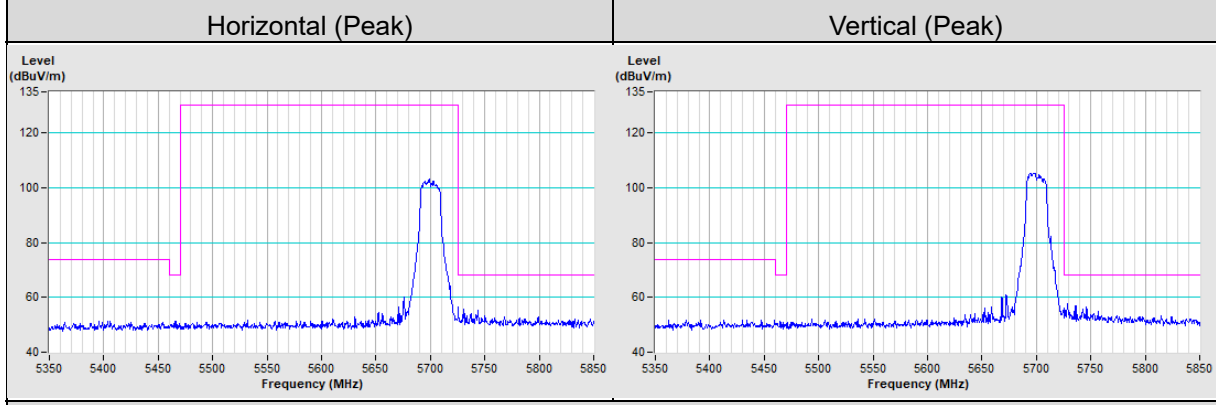

802.11ac (VHT20) Channel 144

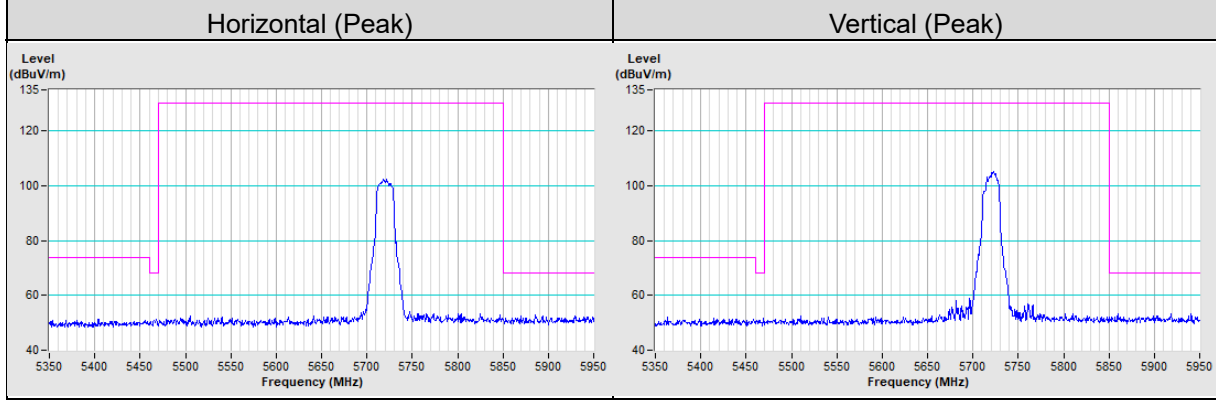

802.11ac (VHT40) Channel 38

Horizontal (Peak)	Horizontal (Average)
--------------------------	-----------------------------

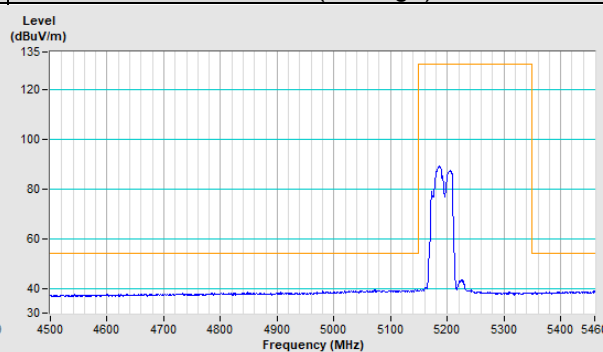
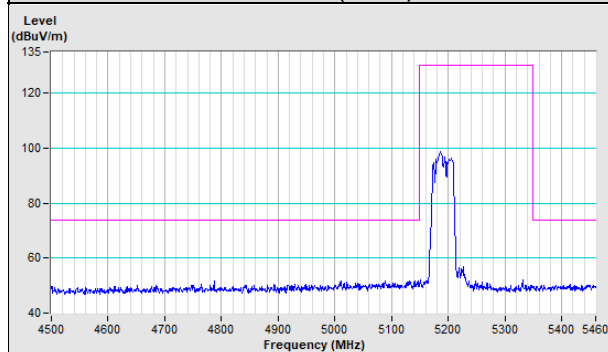

Vertical (Peak)	Vertical (Average)
------------------------	---------------------------

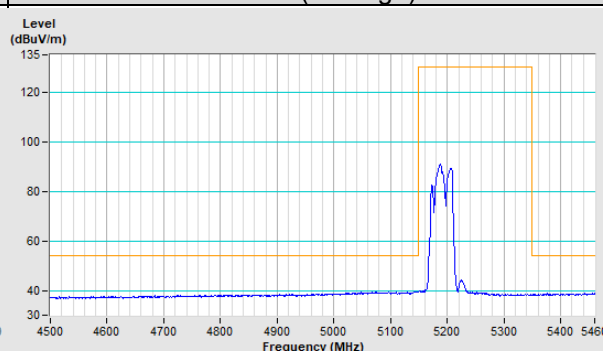
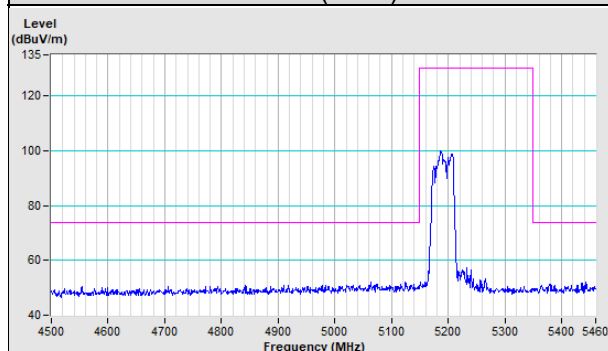

802.11ac (VHT40) Channel 46

Horizontal (Peak)	Horizontal (Average)
--------------------------	-----------------------------

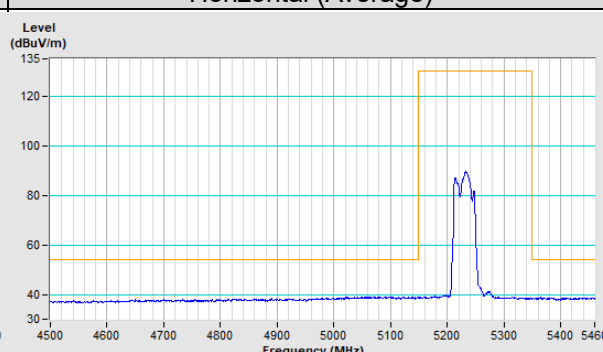
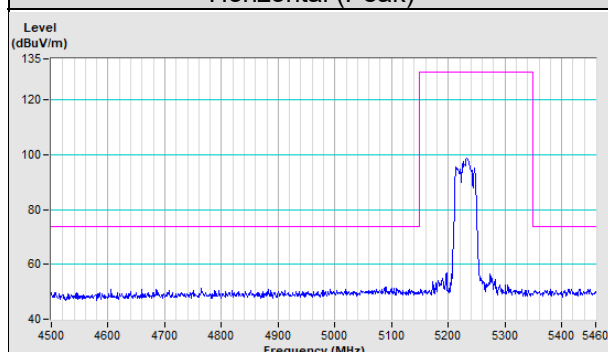

Vertical (Peak)	Vertical (Average)
------------------------	---------------------------

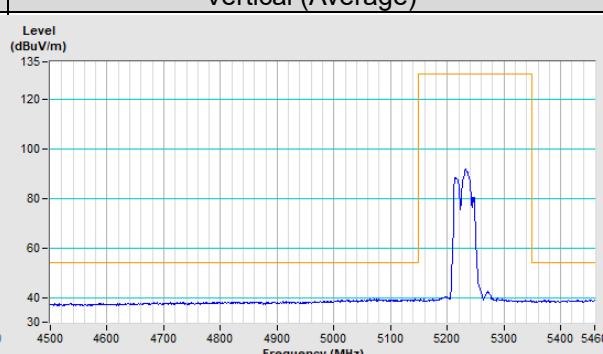
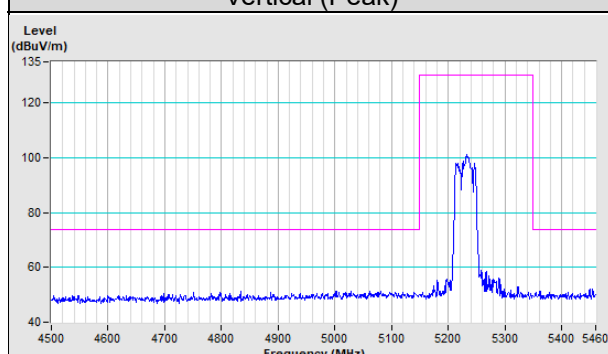

802.11ac (VHT40) Channel 54

Horizontal (Peak)	Horizontal (Average)
-------------------	----------------------

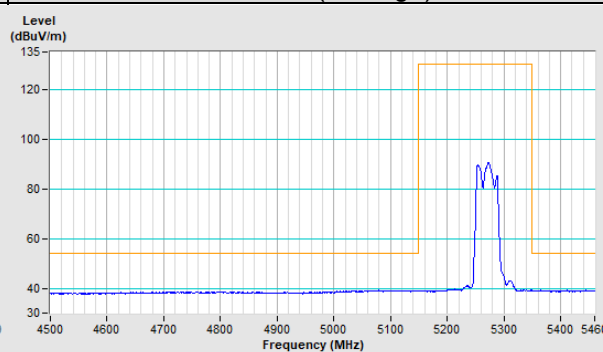
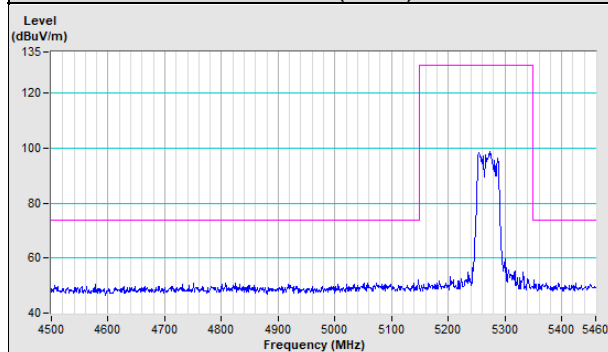

Vertical (Peak)	Vertical (Average)
-----------------	--------------------

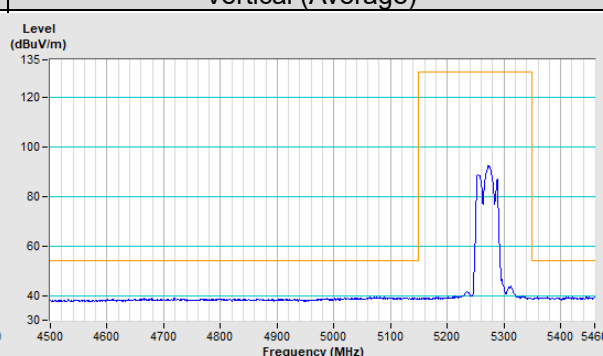
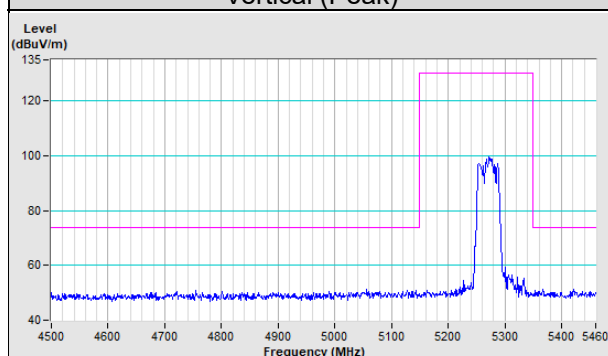

802.11ac (VHT40) Channel 62

Horizontal (Peak)	Horizontal (Average)
-------------------	----------------------

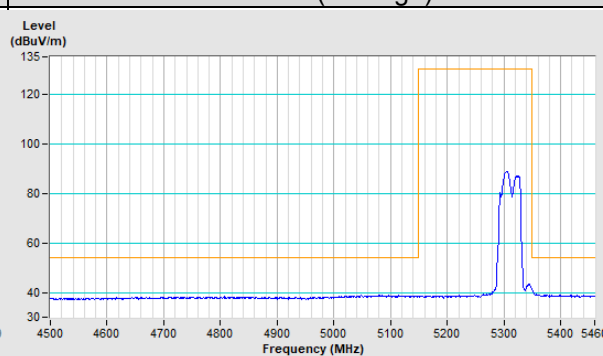
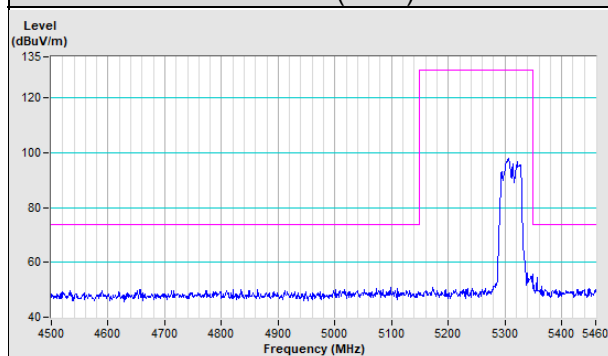

Vertical (Peak)	Vertical (Average)
-----------------	--------------------

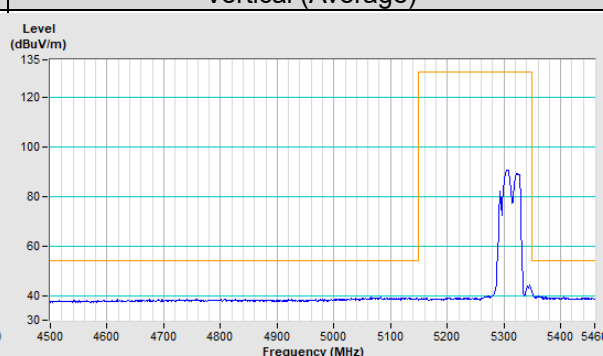
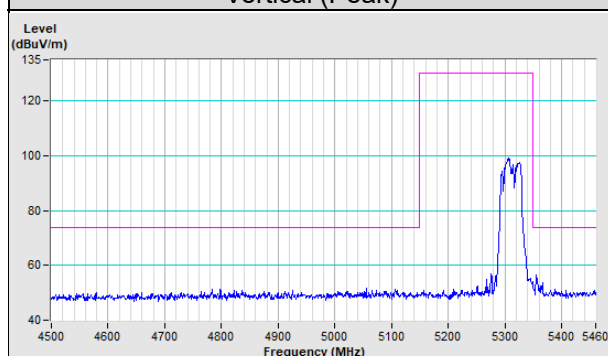

802.11ac (VHT40) Channel 102

Horizontal (Peak)

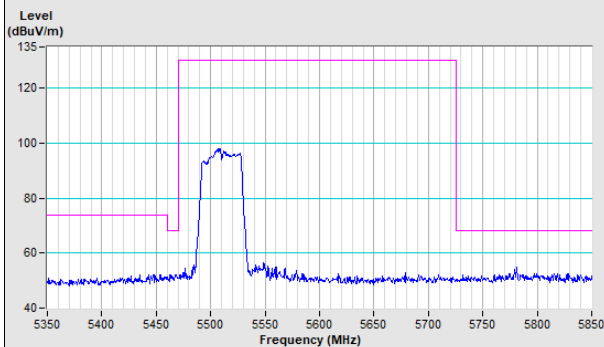

Horizontal (Average)

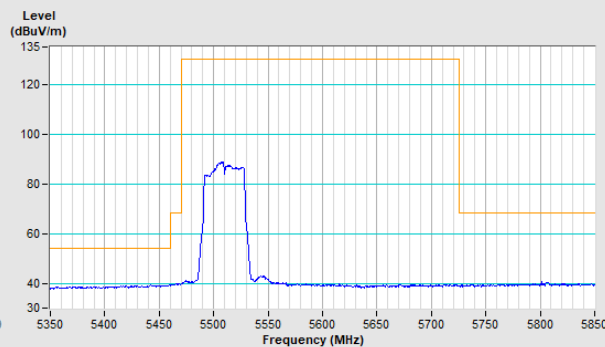

Vertical (Peak)

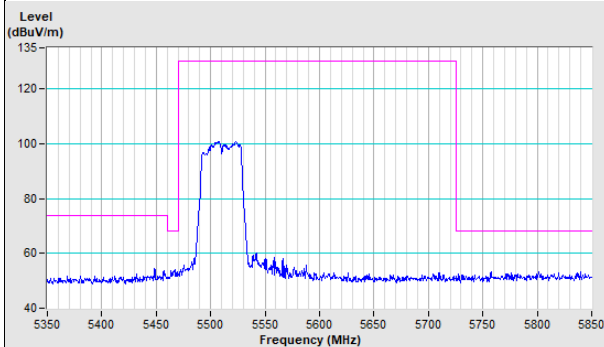

Vertical (Average)

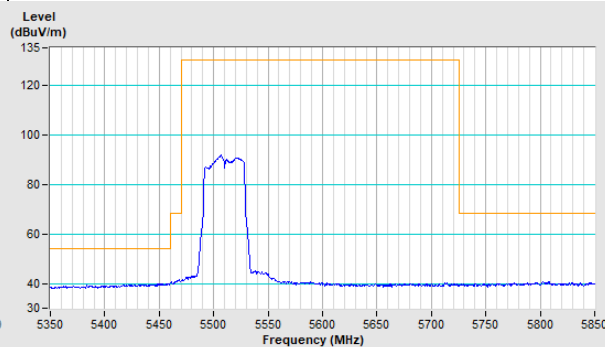

802.11ac (VHT40) Channel 134

Horizontal (Peak)

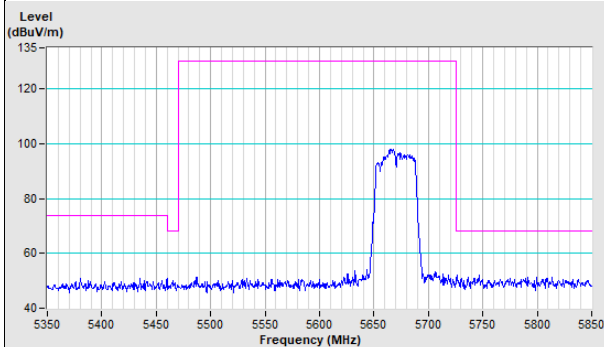

Vertical (Peak)

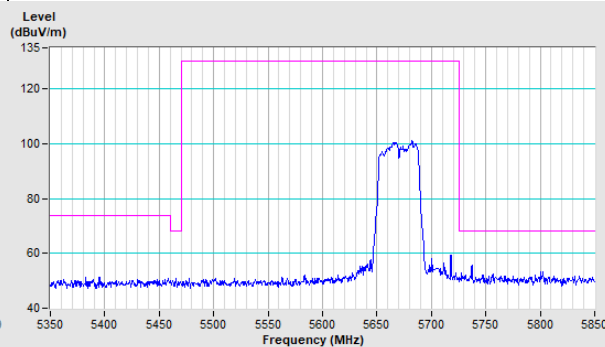

802.11ac (VHT40) Channel 142

Horizontal (Peak)

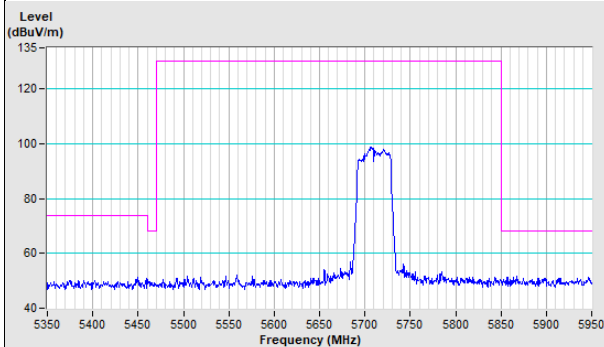

Vertical (Peak)

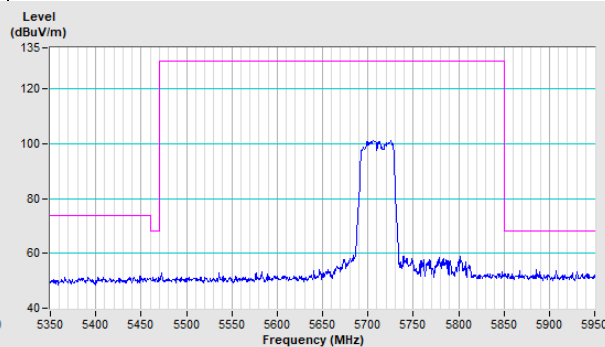

802.11ac (VHT80) Channel 42

Horizontal (Peak)	Horizontal (Average)
--------------------------	-----------------------------

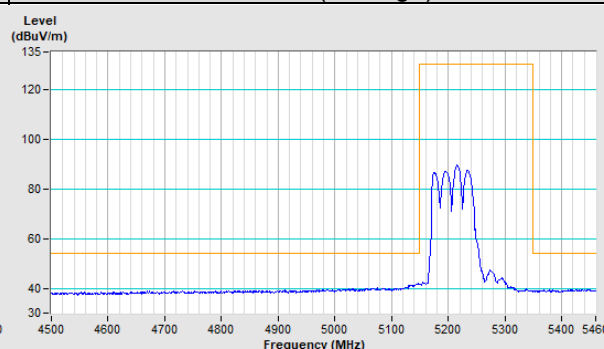
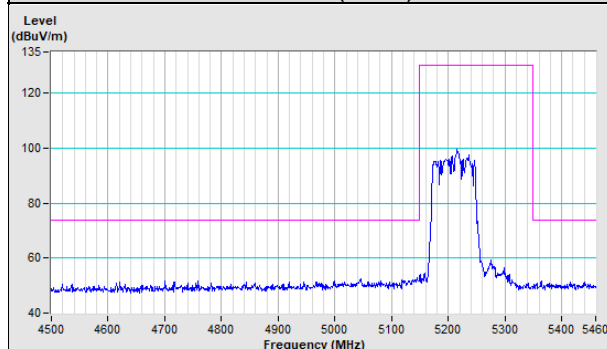

Vertical (Peak)	Vertical (Average)
------------------------	---------------------------

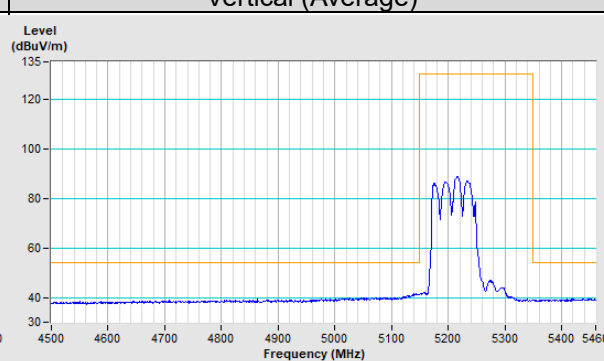
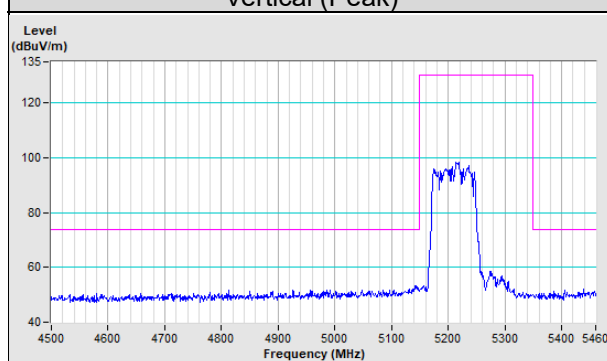

802.11ac (VHT80) Channel 58

Horizontal (Peak)	Horizontal (Average)
--------------------------	-----------------------------

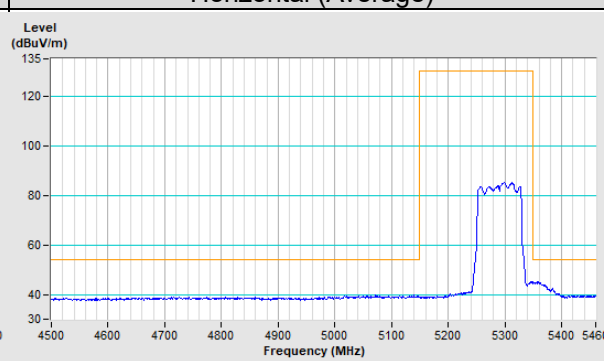
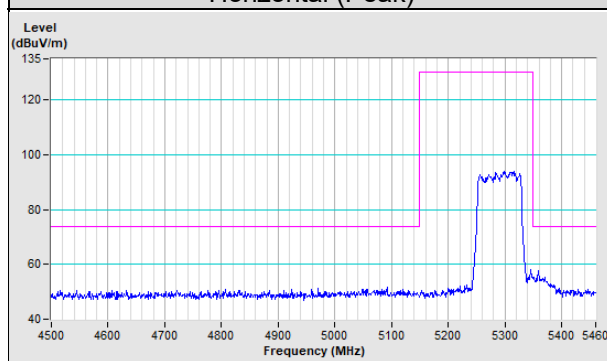

Vertical (Peak)	Vertical (Average)
------------------------	---------------------------

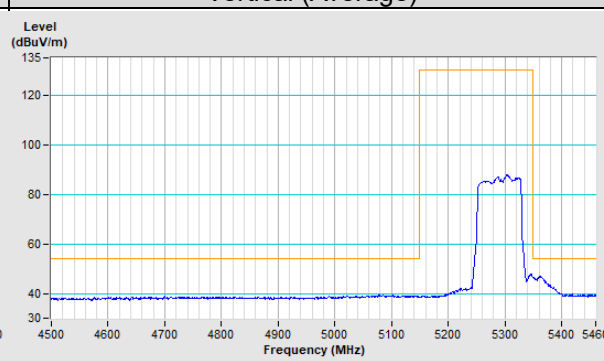
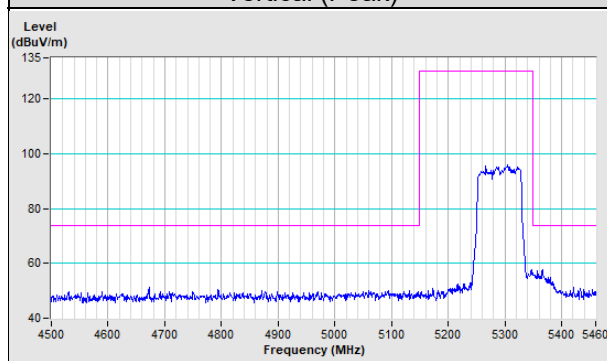

802.11ac (VHT80) Channel 106

Horizontal (Peak)	Horizontal (Average)
--------------------------	-----------------------------

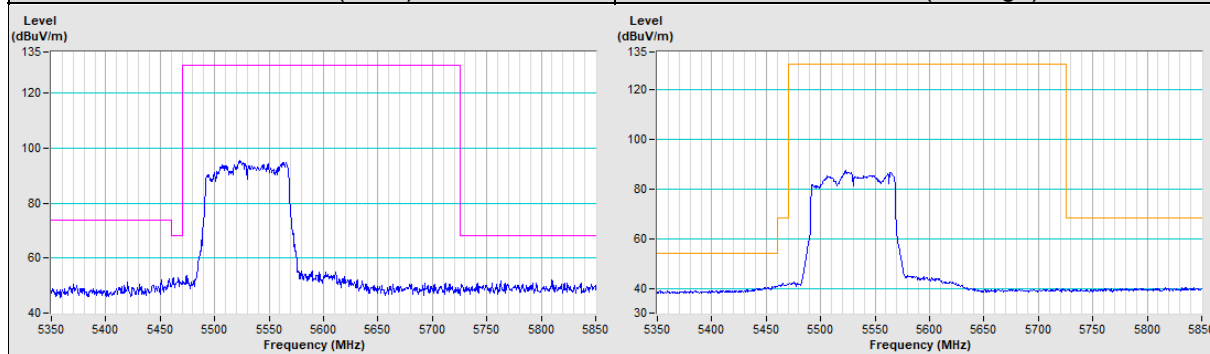

Vertical (Peak)	Vertical (Average)
------------------------	---------------------------

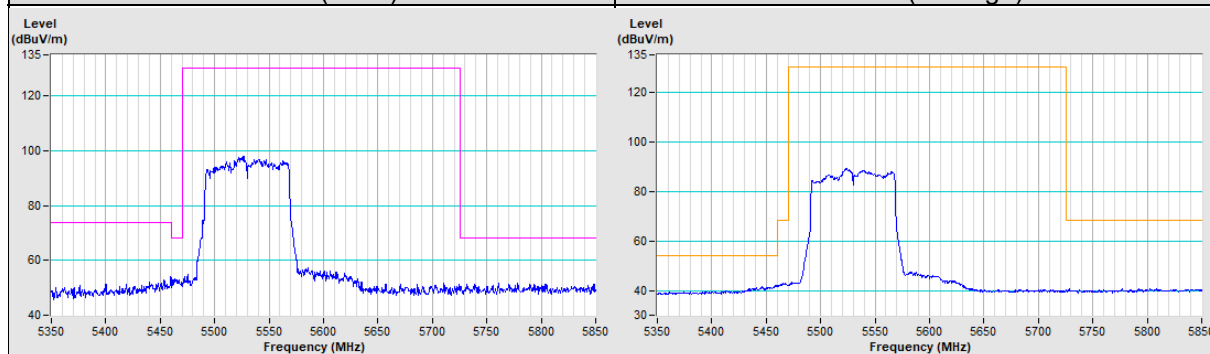

802.11ac (VHT80) Channel 122

Horizontal (Peak)	Horizontal (Average)
--------------------------	-----------------------------

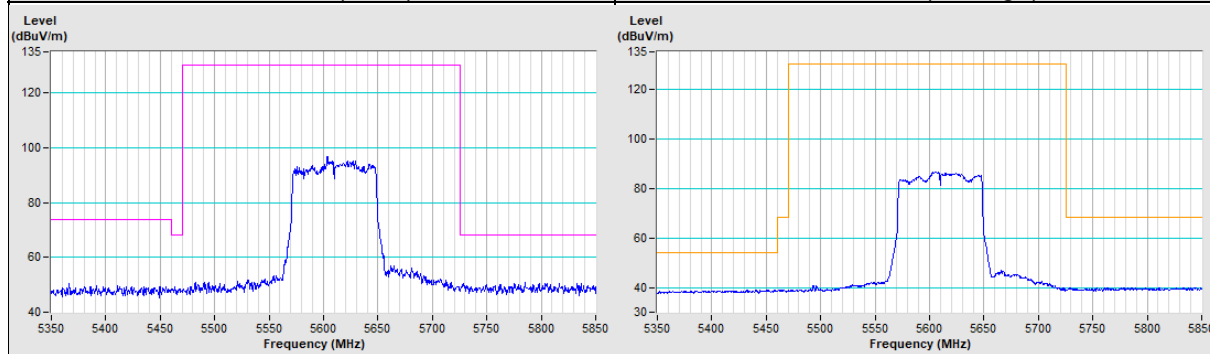

Vertical (Peak)	Vertical (Average)
------------------------	---------------------------

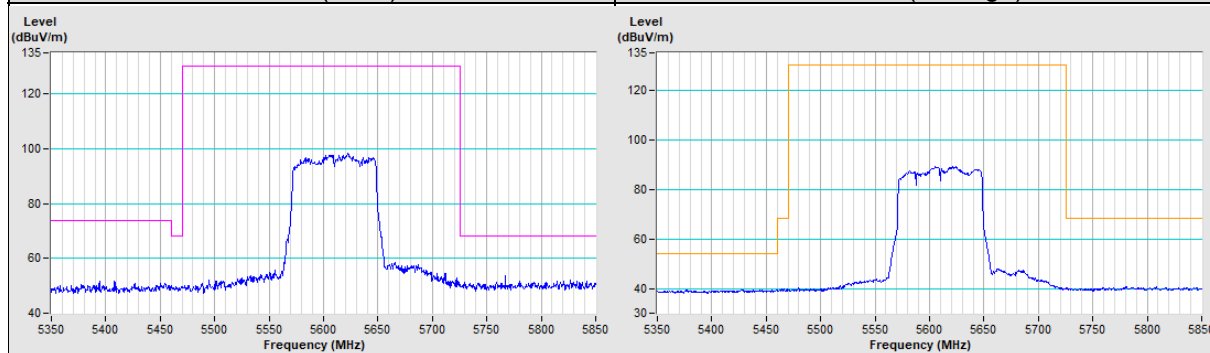

802.11ac (VHT80) Channel 138

Horizontal (Peak)

Vertical (Peak)

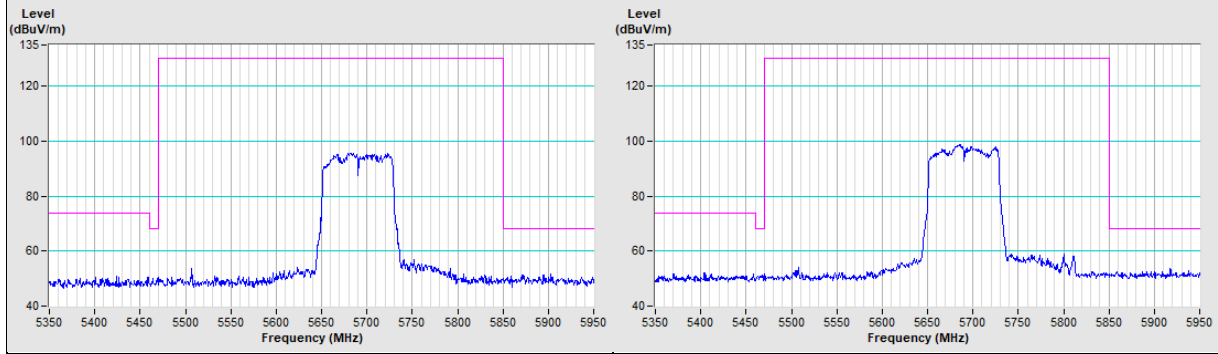

Appendix – Information of the Testing Laboratories

We, Bureau Veritas Consumer Products Services (H.K.) Ltd., Taoyuan Branch, were founded in 1988 to provide our best service in EMC, Radio, Telecom and Safety consultation. Our laboratories are FCC recognized accredited test firms and accredited and approved according to ISO/IEC 17025.

If you have any comments, please feel free to contact us at the following:

Lin Kou EMC/RF Lab

Tel: 886-2-26052180

Fax: 886-2-26051924

Hsin Chu EMC/RF/Telecom Lab

Tel: 886-3-6668565

Fax: 886-3-6668323

Hwa Ya EMC/RF/Safety Lab

Tel: 886-3-3183232

Fax: 886-3-3270892

Email: service.adt@tw.bureauveritas.com

Web Site: www.bureauveritas-adt.com

The address and road map of all our labs can be found in our web site also.

--- END ---