

FCC SAR Test Report

Equipment : 7777-01YY
Brand Name : Orderman
Model No. : 7777-01YY
Marketing Name : NCR Orderman7 MSR,NCR Orderman7 SC
FCC ID : JEH-7777-01YY
Standard : FCC 47 CFR Part 2 (2.1093)
IEEE 1528-2003
Applicant : NCR Corporation
Address : 2651 Satellite Blvd. Duluth, GA 30096 USA
Manufacturer : Universal Global Scientific Industrial Co., Ltd.
Address : 141, Lane 351, Sec.1, Taiping Road,
Tsaotuen, Nantou 54261, Taiwan

The product sample received on Nov. 5, 2014 and completely tested on Dec. 8, 2014. We, SPORTON INTERNATIONAL INC., would like to declare that the tested sample has been evaluated in accordance with the procedures and shown the compliance with the applicable technical standards.

The test results in this report apply exclusively to the tested model / sample. Without written approval of SPORTON INTERNATIONAL INC., the test report shall not be reproduced except in full.

Reviewed by:



Kevin Liang / Assistant Manager





Table of Contents

1	STATEMENT OF COMPLIANCE	5
1.1	Guidance Standard	5
1.2	Testing Location Information	5
1.3	Device Category and SAR Limits	6
2	EQUIPMENT UNDER TEST (EUT)	7
2.1	General Information	7
3	RF EXPOSURE LIMITS	8
3.1	Uncontrolled Environment	8
3.2	Controlled Environment	8
4	SPECIFIC ABSORPTION RATE (SAR)	9
4.1	Introduction	9
4.2	SAR Definition	9
5	SYSTEM DESCRIPTION AND SETUP	10
5.1	E-Field Probe	11
5.2	E-Field Probe Specification	11
5.3	E-Field Probe Calibration	12
5.4	Data Acquisition Electronics (DAE)	12
5.5	Robot	13
5.6	Measurement Server	14
5.7	Phantom	14
6	MEASUREMENT PROCEDURES	15
6.1	Spatial Peak SAR Evaluation	15
6.2	Power Reference Measurement	16
6.3	Area Scan	16
6.4	Zoom Scan	17
6.5	Volume Scan Procedures	17
6.6	Power Drift Monitoring	17
7	TEST EQUIPMENT LIST	18
8	SYSTEM VERIFICATION	19
8.1	Tissue Simulating Liquids	19
8.2	Tissue Verification	20
8.3	Test Conditions	20
8.4	System Performance Check Results	21
9	RF EXPOSURE POSITIONS	22
9.1	SAR Testing for Bar-code scanner	22



10	CONDUCTED RF OUTPUT POWER (UNIT: DBM)	23
11	SAR EXCLUSION CALCULATIONS	28
12	ANTENNA LOCATION	30
13	SAR TEST RESULTS	31
13.1	Test Records for Hands SAR Test.....	31
14	SIMULTANEOUS TRANSMISSION SAR ANALYSIS	32
15	UNCERTAINTY ASSESSMENT	35
16	REFERENCES	38

APPENDIX A. Plots of System Performance Check

APPENDIX B. Plots of SAR Measurement

Appendix C. DASYS Calibration Certificate

Appendix D. Test setup Photos

1 Statement of Compliance

The maximum results of Specific Absorption Rate (SAR) found during testing as follows.

Exposure Position	Frequency Band	Reported 1g SAR (W/kg)	Reported 10g SAR (W/kg)	Equipment Class	Highest Reported 1g SAR (W/kg)	Highest Reported 10g SAR (W/kg)
Body	U-NII-1	0.221	0.245	NII	0.268	0.302
	U-NII-2A	0.241	0.302			
	U-NII-2C	0.268	0.245			
	U-NII-3	0.227	0.191			
	WLAN2.4GHz Band	0.187	0.641	DTS	0.187	0.641

Remark: According to FCC KDB 447498 D01, v05r02)4.3.1) 1), the NFC, OSR and Bluetooth don't need to perform the SAR testing.

For excluding the 125kHz, 902-928MHz and NFC transmitters, they can be referred to Part 2 of FCC rules which state these devices operate under Part 15C rule parts are categorically excluded from RF exposure evaluation.

This device is in compliance with Specific Absorption Rate (SAR) for general population/uncontrolled exposure limits (4.0 W/kg@10g, 1.6W/kg@1g) specified in FCC 47 CFR part 2 (2.1093) and ANSI/IEEE C95.1-1992, and had been tested in accordance with the measurement methods and procedures specified in IEEE 1528-2003.

1.1 Guidance Standard

The Specific Absorption Rate (SAR) testing specification, method, and procedure for this device is in accordance with the following standards:

- FCC 47 CFR Part 2 (2.1093)
- IEEE 1528-2003
- FCC KDB 865664 D01 SAR Measurement 100 MHz to 6 GHz v01r03
- FCC KDB 865664 D02 SAR Reporting v01r01
- FCC KDB 447498 D01 General RF Exposure Guidance v05r02
- FCC KDB 248227 D01 SAR means for 802 11abg v01r02
- FCC KDB 941225 D07 UMPC Mini Tablet v01r01

1.2 Testing Location Information

Testing Location	
HWA YA	ADD : No. 52, Hwa Ya 1 st Rd., Hwa Ya Technology Park, Kwei-Shan Hsiang, Tao Yuan Hsien, Taiwan, R.O.C.
	TEL : 886-3-327-3456 FAX : 886-3-327-0973



1.3 Device Category and SAR Limits

This device belongs to portable device category because its radiating structure is allowed to be used within 20 cm of hands of user. Limit for General Population/Uncontrolled exposure applied for this device is 4.0W/kg as averaged over any 10 gram of tissue and 1.6W/kg as averaged over any 1 gram of tissue.

1.3.1 Test Configuration

During WLAN SAR testing EUT is configured with the WLAN continuous TX tool, and the transmission duty factor was monitored on the spectrum analyzer with zero-span setting Duty factor observed as below:

- 802.11a, 6Mbps: 100%
- 802.11b, 1Mbps: 100%

For WLAN SAR testing, the test device has been configured to transmit continuously at the required data rate, channel bandwidth and signal modulation.



2 Equipment Under Test (EUT)

2.1 General Information

Product Feature & Specification	
Equipment Name	7777-01YY
Brand Name	Orderman
Model Name	7777-01YY
Frequency Range	U-NII-1 : 5150 MHz ~ 5250 MHz U-NII-2A : 5250 MHz ~ 5350 MHz U-NII-2C : 5470 MHz ~ 5725 MHz U-NII-3 : 5725 MHz ~ 5850 MHz WLAN 2.4GHz Band : 2400 MHz ~ 2483.5 MHz
EUT Stage	Production Unit

Specification of Accessory		
Battery	Brand Name	NCR
	Model Name	7777-0105-8801
	Power Rating	3.7V  3150mAh



3 RF Exposure Limits

3.1 Uncontrolled Environment

Uncontrolled Environments are defined as locations where there is the exposure of individuals who have no knowledge or control of their exposure. The general population/uncontrolled exposure limits are applicable to situations in which the general public may be exposed or in which persons who are exposed as a consequence of their employment may not be made fully aware of the potential for exposure or cannot exercise control over their exposure. Members of the general public would come under this category when exposure is not employment-related; for example, in the case of a wireless transmitter that exposes persons in its vicinity.

3.2 Controlled Environment

Controlled Environments are defined as locations where there is exposure that may be incurred by persons who are aware of the potential for exposure, (i.e. as a result of employment or occupation). In general, occupational/controlled exposure limits are applicable to situations in which persons are exposed as a consequence of their employment, who have been made fully aware of the potential for exposure and can exercise control over their exposure. The exposure category is also applicable when the exposure is of a transient nature due to incidental passage through a location where the exposure levels may be higher than the general population/uncontrolled limits, but the exposed person is fully aware of the potential for exposure and can exercise control over his or her exposure by leaving the area or by some other appropriate means.

Limits for Occupational/Controlled Exposure (W/kg)

Whole-Body	Partial-Body	Hands, Wrists, Feet and Ankles
0.4	8.0	20.0

Limits for General Population/Uncontrolled Exposure (W/kg)

Whole-Body	Partial-Body	Hands, Wrists, Feet and Ankles
0.08	1.6	4.0

Whole-Body SAR is averaged over the entire body, partial-body SAR is averaged over any 1gram of tissue defined as a tissue volume in the shape of a cube. SAR for hands, wrists, feet and ankles is averaged over any 10 grams of tissue defined as a tissue volume in the shape of a cube.

4 Specific Absorption Rate (SAR)

4.1 Introduction

SAR is related to the rate at which energy is absorbed per unit mass in an object exposed to a radio field. The SAR distribution in a biological body is complicated and is usually carried out by experimental techniques or numerical modeling. The standard recommends limits for two tiers of groups, occupational/controlled and general population/uncontrolled, based on a person's awareness and ability to exercise control over his or her exposure. In general, occupational/controlled exposure limits are higher than the limits for general population/uncontrolled.

4.2 SAR Definition

The SAR definition is the time derivative (rate) of the incremental energy (dW) absorbed by (dissipated in) an incremental mass (dm) contained in a volume element (dv) of a given density (ρ). The equation description is as below:

$$\mathbf{SAR} = \frac{d}{dt} \left(\frac{dW}{dm} \right) = \frac{d}{dt} \left(\frac{dW}{\rho dv} \right)$$

SAR is expressed in units of Watts per kilogram (W/kg)

$$\mathbf{SAR} = \frac{\sigma |E|^2}{\rho}$$

Where: σ is the conductivity of the tissue, ρ is the mass density of the tissue and E is the RMS electrical field strength.

5 System Description and Setup

The DASY system used for performing compliance tests consists of the following items:

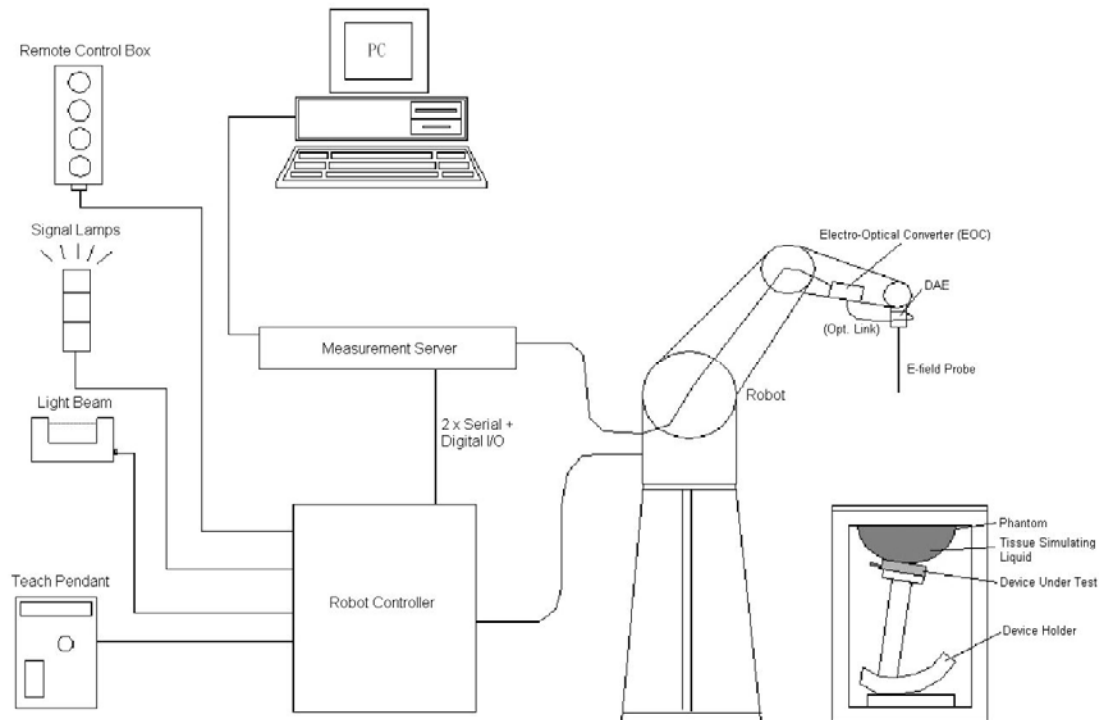

- A standard high precision 6-axis robot with controller, teach pendant and software. An arm extension for accommodating the data acquisition electronics (DAE).
- An isotropic Field probe optimized and calibrated for the targeted measurement.
- A data acquisition electronics (DAE) which performs the signal amplification, signal multiplexing, AD-conversion, offset measurements, mechanical surface detection, collision detection, etc. The unit is battery powered with standard or rechargeable batteries. The signal is optically transmitted to the EOC.
- The Electro-optical converter (EOC) performs the conversion from optical to electrical signals for the digital communication to the DAE. To use optical surface detection, a special version of the EOC is required. The EOC signal is transmitted to the measurement server.
- The function of the measurement server is to perform the time critical tasks such as signal filtering, control of the robot operation and fast movement interrupts.
- The Light Beam used is for probe alignment. This improves the (absolute) accuracy of the probe positioning.
- A computer running WinXP or Win7 and the DASY5 software.
- Remote control and teach pendant as well as additional circuitry for robot safety such as warning lamps, etc.
- The phantom, the device holder and other accessories according to the targeted measurement.

5.1 E-Field Probe

The SAR measurement is conducted with the dosimetric probe (manufactured by SPEAG).The probe is specially designed and calibrated for use in liquid with high permittivity. The dosimetric probe has special calibration in liquid at different frequency. This probe has a built in optical surface detection system to prevent from collision with phantom.

5.2 E-Field Probe Specification

<EX3DV4 Probe>

Construction	Symmetrical design with triangular core Built-in shielding against static charges PEEK enclosure material (resistant to organic solvents, e.g., DGBE)
Frequency	10 MHz to 6 GHz; Linearity: ± 0.2 dB
Directivity	± 0.3 dB in HSL (rotation around probe axis) ± 0.5 dB in tissue material (rotation normal to probe axis)
Dynamic Range	10 μ W/g to 100 mW/g; Linearity: ± 0.2 dB (noise: typically < 1 μ W/g)
Dimensions	Overall length: 330 mm (Tip: 20 mm) Tip diameter: 2.5 mm (Body: 12 mm) Typical distance from probe tip to dipole centers: 1 mm



5.3 E-Field Probe Calibration

Each probe needs to be calibrated according to a dosimetric assessment procedure with accuracy better than $\pm 10\%$. The spherical isotropy shall be evaluated and within $\pm 0.25\text{dB}$. The sensitivity parameters (NormX, NormY, and NormZ), the diode compression parameter (DCP) and the conversion factor (ConvF) of the probe are tested. The calibration data can be referred to appendix C of this report.

5.4 Data Acquisition Electronics (DAE)

The data acquisition electronics (DAE) consists of a highly sensitive electrometer-grade preamplifier with auto-zeroing, a channel and gain-switching multiplexer, a fast 16 bit AD-converter and a command decoder and control logic unit. Transmission to the measurement server is accomplished through an optical downlink for data and status information as well as an optical uplink for commands and the clock. The input impedance of the DAE is 200 MOhm; the inputs are symmetrical and floating. Common mode rejection is above 80 dB.



5.5 Robot

The SPEAG DASY system uses the high precision robots (DASY4: RX90BL; DASY5: TX90XL) type from Stäubli SA (France). The Stäubli robot series have many features that are important for our application:

- High precision (repeatability ± 0.035 mm)
- High reliability (industrial design)
- Jerk-free straight movements
- Low ELF interference (the closed metallic construction shields against motor control fields)



5.6 Measurement Server

The measurement server is based on a PC/104 CPU board with CPU (DASY5: 400 MHz, Intel Celeron), chipdisk (DASY5: 128 MB), RAM (DASY5: 128 MB). The necessary circuits for communication with the DAE electronic box, as well as the 16 bit AD converter system for optical detection and digital I/O interface are contained on the DASY I/O board, which is directly connected to the PC/104 bus of the CPU board. The measurement server performs all the real-time data evaluation for field measurements and surface detection, controls robot movements and handles safety operations.



5.7 Phantom

Shell Thickness	2 ± 0.2 mm (sagging: <1%)
Filling Volume	Approx. 30 liters
Dimensions	Major ellipse axis: 600 mm Minor axis: 400 mm



The ELI4 phantom is intended for compliance testing of handheld and body-mounted wireless devices in the frequency range of 30 MHz to 6 GHz. ELI4 is fully compatible with standard and all known tissue simulating liquids.

6 Measurement Procedures

The measurement procedures are as follows:

<Conducted power measurement>

- (a) For WLAN/BT power measurement, use engineering software to configure EUT WLAN/BT continuously transmission, at maximum RF power in each supported wireless interface and frequency band
- (b) Connect EUT RF port through RF cable to the power meter, and measure WLAN/BT output power

<SAR measurement>

- (a) Place the EUT in the positions as Appendix D demonstrates.
- (b) Set scan area, grid size and other setting on the DASY software.
- (c) Measure SAR results for the highest power channel on each testing position.
- (d) Find out the largest SAR result on these testing positions of each band
- (e) Measure SAR results for other channels in worst SAR testing position if the reported SAR of highest power channel is larger than 0.8 W/kg

According to the test standard, the recommended procedure for assessing the peak spatial-average SAR value consists of the following steps:

- (a) Area scan
- (b) Power reference measurement
- (c) Zoom scan
- (d) Power drift measurement

6.1 Spatial Peak SAR Evaluation

The procedure for spatial peak SAR evaluation has been implemented according to the test standard. It can be conducted for 1g and 10g, as well as for user-specific masses. The DASY software includes all numerical procedures necessary to evaluate the spatial peak SAR value.

The base for the evaluation is a "cube" measurement. The measured volume must include the 1g and 10g cubes with the highest averaged SAR values. For that purpose, the center of the measured volume is aligned to the interpolated peak SAR value of a previously performed area scan.

The entire evaluation of the spatial peak values is performed within the post-processing engine (SEMCAD). The system always gives the maximum values for the 1g and 10g cubes. The algorithm to find the cube with highest averaged SAR is divided into the following stages:

- (a) Extraction of the measured data (grid and values) from the Zoom Scan
- (f) Calculation of the SAR value at every measurement point based on all stored data (A/D values and measurement parameters)
- (b) Generation of a high-resolution mesh within the measured volume
- (c) Interpolation of all measured values from the measurement grid to the high-resolution grid
- (d) Extrapolation of the entire 3-D field distribution to the phantom surface over the distance from sensor to surface
- (e) Calculation of the averaged SAR within masses of 1g and 10g

6.2 Power Reference Measurement

The Power Reference Measurement and Power Drift Measurements are for monitoring the power drift of the device under test in the batch process. The minimum distance of probe sensors to surface determines the closest measurement point to phantom surface. This distance cannot be smaller than the distance of sensor calibration points to probe tip as defined in the probe properties.

6.3 Area Scan

The area scan is used as a fast scan in two dimensions to find the area of high field values, before doing a fine measurement around the hot spot. The sophisticated interpolation routines implemented in DASY software can find the maximum found in the scanned area, within a range of the global maximum. The range (in dB) is specified in the standards for compliance testing. For example, a 2 dB range is required in IEEE standard 1528 and IEC 62209 standards, whereby 3 dB is a requirement when compliance is assessed in accordance with the ARIB standard (Japan), if only one zoom scan follows the area scan, then only the absolute maximum will be taken as reference. For cases where multiple maximums are detected, the number of zoom scans has to be increased accordingly.

Area scan parameters extracted from FCC KDB 865664 D01v01r03 SAR measurement 100 MHz to 6 GHz v01r01.

	≤ 3 GHz	> 3 GHz
Maximum distance from closest measurement point (geometric center of probe sensors) to phantom surface	5 ± 1 mm	$\frac{1}{2} \cdot \delta \cdot \ln(2) \pm 0.5$ mm
Maximum probe angle from probe axis to phantom surface normal at the measurement location	30° ± 1°	20° ± 1°
Maximum area scan spatial resolution: $\Delta x_{Area}, \Delta y_{Area}$	≤ 2 GHz: ≤ 15 mm 2 – 3 GHz: ≤ 12 mm	3 – 4 GHz: ≤ 12 mm 4 – 6 GHz: ≤ 10 mm
	When the x or y dimension of the test device, in the measurement plane orientation, is smaller than the above, the measurement resolution must be ≤ the corresponding x or y dimension of the test device with at least one measurement point on the test device.	

6.4 Zoom Scan

Zoom scans are used assess the peak spatial SAR values within a cubic averaging volume containing 1 gram and 10 gram of simulated tissue. The zoom scan measures points (refer to table below) within a cube shoes base faces are centered on the maxima found in a preceding area scan job within the same procedure. When the measurement is done, the zoom scan evaluates the averaged SAR for 1 gram and 10 gram and displays these values next to the job's label.

Zoom scan parameters extracted from FCC KDB 865664 D01v01r03 SAR measurement 100 MHz to 6 GHz v01r01.

		≤ 3 GHz	> 3 GHz	
Maximum zoom scan spatial resolution: $\Delta x_{Zoom}, \Delta y_{Zoom}$		≤ 2 GHz: ≤ 8 mm 2 – 3 GHz: ≤ 5 mm*	3 – 4 GHz: ≤ 5 mm* 4 – 6 GHz: ≤ 4 mm*	
Maximum zoom scan spatial resolution, normal to phantom surface	uniform grid: $\Delta z_{Zoom}(n)$	≤ 5 mm	3 – 4 GHz: ≤ 4 mm 4 – 5 GHz: ≤ 3 mm 5 – 6 GHz: ≤ 2 mm	
	graded grid	$\Delta z_{Zoom}(1)$: between 1 st two points closest to phantom surface	≤ 4 mm	3 – 4 GHz: ≤ 3 mm 4 – 5 GHz: ≤ 2.5 mm 5 – 6 GHz: ≤ 2 mm
		$\Delta z_{Zoom}(n>1)$: between subsequent points	$\leq 1.5 \cdot \Delta z_{Zoom}(n-1)$	
Minimum zoom scan volume	x, y, z	≥ 30 mm	3 – 4 GHz: ≥ 28 mm 4 – 5 GHz: ≥ 25 mm 5 – 6 GHz: ≥ 22 mm	
Note: δ is the penetration depth of a plane-wave at normal incidence to the tissue medium; see draft standard IEEE P1528-2011 for details. * When zoom scan is required and the <i>reported</i> SAR from the <i>area scan based 1-g SAR estimation</i> procedures of KDB 447498 is ≤ 1.4 W/kg, ≤ 8 mm, ≤ 7 mm and ≤ 5 mm zoom scan resolution may be applied, respectively, for 2 GHz to 3 GHz, 3 GHz to 4 GHz and 4 GHz to 6 GHz.				

6.5 Volume Scan Procedures

The volume scan is used for assess overlapping SAR distributions for antennas transmitting in different frequency bands. It is equivalent to an oversized zoom scan used in standalone measurements. The measurement volume will be used to enclose all the simultaneous transmitting antennas. For antennas transmitting simultaneously in different frequency bands, the volume scan is measured separately in each frequency band. In order to sum correctly to compute the 1g aggregate SAR, the EUT remain in the same test position for all measurements and all volume scan use the same spatial resolution and grid spacing. When all volume scan were completed, the software, SEMCAD postprocessor can combine and subsequently superpose these measurement data to calculating the multiband SAR.

6.6 Power Drift Monitoring

All SAR testing is under the EUT install full charged battery and transmit maximum output power. In DASY measurement software, the power reference measurement and power drift measurement procedures are used for monitoring the power drift of EUT during SAR test. Both these procedures measure the field at a specified reference position before and after the SAR testing. The software will calculate the field difference in dB. If the power drifts more than 5%, the SAR will be retested.



7 Test Equipment List

Manufacturer	Name of Equipment	Type/Model	Serial Number	Calibration	
				Last Cal.	Due Date
SPEAG	Data Acquisition Electronics	DAE4	1424	2014/2/11	2015/2/10
SPEAG	Dosimetric E-Field Probe	EX3DV4	3976_01	2014/2/17	2015/2/16
SPEAG	2450MHz System Validation Kit	D2450V2	929_01	2014/2/12	2015/2/11
SPEAG	5000MHz System Validation Kit	D5GHzV2	1171_01	2014/2/13	2015/2/12
SPEAG	Device Holder	N/A	N/A	NCR	NCR
Mini-Circuits	Power Amplifier	ZHL-42W+	15542	NCR	NCR
Mini-Circuits	Power Amplifier	ZVE-8G+	605601404	NCR	NCR
Agilent	ENA Series Network Analyzer	E5071C	MY46419201	2014/1/15	2015/1/14
Agilent	EXA Signal Analyzer	N9010A	MY54200432	2014/8/16	2015/8/15
Agilent	MXG-B RF Vector Signal Generator	N5182B	MY53050081	2014/4/8	2015/4/7
SPEAG	Dielectric Probe Kit	SM DAK 040CA	1146	NCR	NCR
Anritsu	Power Meter	ML2495A	949003	2014/1/28	2015/1/27
Anritsu	Power sensor	MA2411B	917017	2014/1/28	2015/1/27
Anritsu	Radio Communication Analyzer	MT8820C	6201240341	2014/3/18	2015/3/17
SPEAG	Flat Phantom ELI5.0	QD OVA 002 AA	1238	NCR	NCR
Wisewind	Themometer	HTC1	HTC1	2013/12/25	2014/12/24
Wisewind	Themometer	YF-160A	130504609	2013/12/25	2014/12/24

General Note:

1. The calibration certificate of DASY can be referred to appendix C of this report.
2. The Insertion Loss calibration of Dual Directional Coupler and Attenuator were characterized via the network analyzer and compensated during system check.
3. In system check we need to monitor the level on the power meter, and adjust the power amplifier level to have precise power level to the dipole; the measured SAR will be normalized to 1W input power according to the ratio of 1W to the input power to the dipole. For system check, the calibration of the power amplifier is deemed not critically required for correct measurement; the power meter is critical and we do have calibration for it
4. Attenuator 1 insertion loss is calibrated by the network Analyzer, which the calibration is valid, before system check.
5. NCR: No calibration request.

8 System Verification

8.1 Tissue Simulating Liquids

For the measurement of the field distribution inside the phantom with DASY, the phantom must be filled with around 25 liters of homogeneous body tissue simulating liquid. For body SAR testing, the liquid height from the center of the flat phantom to the liquid top surface is larger than 15 cm, which is shown in Fig. 8.1.



Fig 8.1 Photo of Liquid Height for Body SAR

8.2 Tissue Verification

The following tissue formulations are provided for reference only as some of the parameters have not been thoroughly verified. The composition of ingredients may be modified accordingly to achieve the desired target tissue parameters required for routine SAR evaluation.

Frequency (MHz)	Water (%)	Sugar (%)	Cellulose (%)	Salt (%)	Preventol (%)	DGBE (%)	Conductivity (σ)	Permittivity (ϵ_r)
750	41.1	57.0	0.2	1.4	0.2	0	0.89	41.9
835	40.3	57.9	0.2	1.4	0.2	0	0.90	41.5
900	40.3	57.9	0.2	1.4	0.2	0	0.97	41.5
1800, 1900, 2000	55.2	0	0	0.3	0	44.5	1.40	40.0
2450	55.0	0	0	0	0	45.0	1.80	39.2
2600	54.8	0	0	0.1	0	45.1	1.96	39.0

Simulating Liquid for 5GHz, Manufactured by SPEAG

Ingredients	(% by weight)
Water	64~78%
Mineral oil	11~18%
Emulsifiers	9~15%
Additives and Salt	2~3%

8.3 Test Conditions

<Ambient Condition>

Ambient Temperature	23 to 24 °C
Humidity	63 to 65%

<Tissue Dielectric Parameter Check Results>

Frequency (MHz)	Liquid Temp. (°C)	Conductivity (σ)	Permittivity (ϵ_r)	Conductivity Target (σ)	Permittivity Target (ϵ_r)	Delta (σ) (%)	Delta (ϵ_r) (%)	Limit (%)	SAR (1g or 10g)	Date
2450	22.7	2.002	51.299	2.002	51.299	2.67	-2.66	±5	10g	2014/11/25
2450	22.9	1.999	51.348	1.999	51.348	2.51	-2.57	±5	10g	2014/12/2
2450	22.9	1.997	51.352	1.997	51.352	2.41	-2.56	±5	1g	2014/12/8
5200	22.8	5.288	47.486	5.288	47.486	-0.23	-3.09	±5	10g	2014/12/3
5200	22.9	5.296	47.633	5.296	47.633	-0.08	-2.79	±5	1g	2014/12/8
5300	22.8	5.416	47.311	5.416	47.311	-0.07	-3.25	±5	10g	2014/12/3
5300	22.9	5.424	47.459	5.424	47.459	0.07	-2.95	±5	1g	2014/12/8
5600	22.8	5.817	46.818	5.817	46.818	0.81	-3.47	±5	10g	2014/12/3
5600	22.9	5.827	46.964	5.827	46.964	0.99	-3.17	±5	1g	2014/12/8
5800	22.8	6.089	46.49	6.089	46.49	1.48	-3.55	±5	10g	2014/12/3
5800	22.9	6.098	46.631	6.098	46.631	1.63	-3.26	±5	1g	2014/12/8

8.4 System Performance Check Results

Comparing to the original SAR value provided by SPEAG, the verification data should be within its specification of 10 %. Below table shows the target SAR and measured SAR after normalized to 1W input power. The table below indicates the system performance check can meet the variation criterion and the plots can be referred to Appendix A of this report.

Frequency (MHz)	Input Power (mW)	Targeted SAR (W/kg)	Measured SAR (W/kg)	Normalized SAR (W/kg)	Deviation (%)	Probe S/N	DAE S/N	Dipole S/N	SAR (1g or 10g)	Date
2450	250mW	23.9	5.55	22.20	-7.113	3976	1424	929	10g	2014/11/25
2450	250mW	23.9	5.50	22.00	-7.950	3976	1424	929	10g	2014/12/2
2450	250mW	51.4	11.80	47.20	-8.171	3976	1424	929	1g	2014/12/8
5200	100mW	20.7	2.06	20.60	-0.483	3976	1424	1171	10g	2014/12/3
5200	100mW	74.0	7.19	71.90	-2.838	3976	1424	1171	1g	2014/12/8
5300	100mW	21.1	2.12	21.20	0.474	3976	1424	1171	10g	2014/12/3
5300	100mW	75.1	7.43	21.20	0.474	3976	1424	1171	1g	2014/12/8
5600	100mW	22.1	2.04	20.40	-7.692	3976	1424	1171	10g	2014/12/3
5600	100mW	79.7	7.82	78.20	-1.882	3976	1424	1171	1g	2014/12/8
5800	100mW	20.5	1.99	19.90	-2.927	3976	1424	1171	10g	2014/12/3
5800	100mW	74.1	6.84	68.40	-7.692	3976	1424	1171	1g	2014/12/8

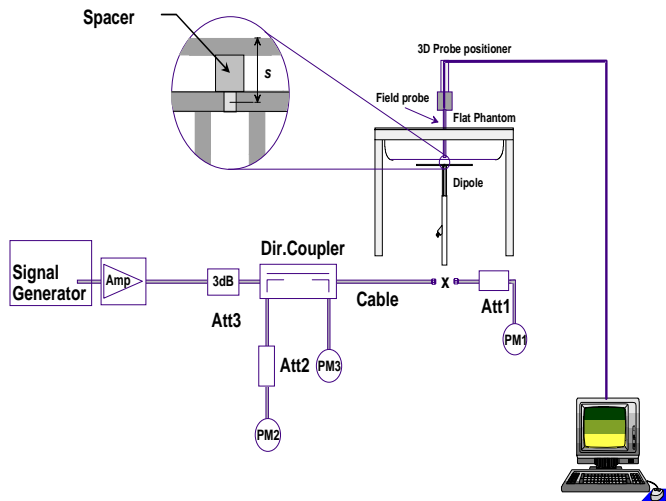

System Performance Check Setup



Setup Photo



9 RF Exposure Positions

9.1 SAR Testing for Bar-code scanner

Please refer to Appendix D. for the test setup photos.



10 Conducted RF Output Power (Unit: dBm)

<WLAN Conducted Power>

General Note:

1. Per FCC KDB 248227 D01 v01r02, choose the highest output power channel to test SAR and determine further SAR exclusion.
2. For each frequency band, testing at higher data rates and higher order modulations is not required when the maximum average output power for each of these configurations is less than 1/4dB higher than those measured at the lowest data rate.

<2.4GHz WLAN Antenna>

WLAN 2.4GHz 802.11b Average Power (dBm)			Tune up Limit (dBm)
Power vs. Channel			
Channel	Frequency (MHz)	Data Rate 1Mbps	
CH 1	2412	17.11	17.50
CH 6	2437	17.18	
CH 11	2462	17.23	

WLAN 2.4GHz 802.11g Average Power (dBm)			Tune up Limit (dBm)
Power vs. Channel			
Channel	Frequency (MHz)	Data Rate 6Mbps	
CH 1	2412	14.16	14.50
CH 6	2437	13.84	
CH 11	2462	13.82	

WLAN 2.4GHz 802.11n-HT20 Average Power (dBm)			Tune up Limit (dBm)
Power vs. Channel			
Channel	Frequency (MHz)	Data Rate MCS0	
CH 1	2412	12.81	13.00
CH 6	2437	12.98	
CH 11	2462	12.98	



General Note:

1. Per FCC KDB 248227 D01 v01r02, choose the highest output power channel to test SAR and determine further SAR exclusion
2. For each frequency band, testing at higher data rates and higher order modulations is not required when the maximum average output power for each of these configurations is less than 1/4dB higher than those measured at the lowest data rate.
3. Per FCC KDB 248227 D01 v01r02, 11n-HT20 output power is less than 1/4dB higher than 11a mode, thus the SAR can be excluded.

<U-NII-1 Antenna>

WLAN 5.2GHz 802.11a Average Power (dBm)			Tune up Limit (dBm)
Power vs. Channel			
Channel	Frequency (MHz)	Data Rate 6Mbps	
CH 36	5180	14.15	14.50
CH 40	5200	14.19	
CH 44	5220	14.06	
CH 48	5240	14.09	

WLAN 5.2GHz 802.11n-HT20 Average Power (dBm)			Tune up Limit (dBm)
Power vs. Channel			
Channel	Frequency (MHz)	MCS Index MCS0	
CH 36	5180	13.24	13.50
CH 40	5200	12.97	
CH 44	5220	13.11	
CH 48	5240	13.18	



<U-NII-2A Antenna>

WLAN 5.3GHz 802.11a Average Power (dBm)			Tune up Limit (dBm)
Power vs. Channel			
Channel	Frequency (MHz)	Data Rate 6Mbps	
CH 52	5260	14.03	14.50
CH 56	5280	14.02	
CH 60	5300	14.08	
CH 64	5320	13.90	

WLAN 5.3GHz 802.11n-HT20 Average Power (dBm)			Tune up Limit (dBm)
Power vs. Channel			
Channel	Frequency (MHz)	MCS Index MCS0	
CH 52	5260	13.13	13.50
CH 56	5280	13.08	
CH 60	5300	13.21	
CH 64	5320	13.10	



<U-NII-2C Antenna>

WLAN 5.6GHz 802.11a Average Power (dBm)			Tune up Limit (dBm)
Power vs. Channel			
Channel	Frequency (MHz)	Data Rate 6Mbps	
CH 100	5500	14.24	14.50
CH 104	5520	14.20	
CH 108	5540	14.17	
CH 112	5560	14.21	
CH 116	5580	14.11	
CH 120	5600	13.87	
CH 124	5620	13.97	
CH 128	5640	13.83	
CH 132	5660	13.94	
CH 136	5680	13.90	
CH 140	5700	13.92	

WLAN 5.6GHz 802.11n-HT20 Average Power (dBm)			Tune up Limit (dBm)
Power vs. Channel			
Channel	Frequency (MHz)	MCS Index MCS0	
CH 100	5500	12.84	13.50
CH 104	5520	12.79	
CH 108	5540	12.83	
CH 112	5560	12.79	
CH 116	5580	13.03	
CH 120	5600	12.75	
CH 124	5620	12.96	
CH 128	5640	12.84	
CH 132	5660	12.89	
CH 136	5680	12.85	
CH 140	5700	13.01	



<U-NII-3 Antenna>

WLAN 5.8GHz 802.11a Average Power (dBm)			Tune up Limit (dBm)
Power vs. Channel			
Channel	Frequency (MHz)	Data Rate 6Mbps	
CH 149	5745	14.22	14.50
CH 153	5765	14.18	
CH 157	5785	14.24	
CH 161	5805	14.06	
CH 165	5825	14.02	

WLAN 5.8GHz 802.11n-HT20 Average Power (dBm)			Tune up Limit (dBm)
Power vs. Channel			
Channel	Frequency (MHz)	MCS Index MCS0	
CH 149	5745	13.00	13.50
CH 153	5765	12.77	
CH 157	5785	12.98	
CH 161	5805	12.89	
CH 165	5825	13.08	

11 SAR Exclusion Calculations

<1g-SAR Exclusion Calculations for Wi-Fi Antenna < 50mm from the User>

According to KDB 447498 v05 r02 in section 4.3.1:

The 1-g SAR test exclusion thresholds for 100 MHz to 6 GHz at *test separation distances* ≤ 50 mm are determined by:

$$[(\text{max. power of channel, including tune-up tolerance, mW}) / (\text{min. test separation distance, mm})] \cdot$$

$$[\sqrt{f_{(\text{GHz})}}] \leq 3.0 \text{ for 1-g SAR, where}$$

- $f_{(\text{GHz})}$ is the RF channel transmit frequency in GHz
- Power and distance are rounded to the nearest mW and mm before calculation
- The result is rounded to one decimal place for comparison

Antenna	Band	Mode	Frequency (MHz)	Output Power		Separation Distances(mm)			Calculated Threshold Value		
				dBm	mW	Front Face	Rear Face	Left Side	Front Face	Rear Face	Left Side
Wi-Fi Main	2.4GHz	802.11b	2437	17.5	56	5.0	5.0	5.0	9.6	9.6	9.6
	2.4GHz	802.11g	2437	14.5	28	5.0	5.0	5.0	9.6	9.6	9.6
	2.4GHz	802.11n HT20	2437	13.0	20	5.0	5.0	5.0	9.6	9.6	9.6
	U-NII-1	802.11a	5200	14.5	28	5.0	5.0	5.0	6.6	6.6	6.6
	U-NII-2A		5300	14.5	28	5.0	5.0	5.0	6.5	6.5	6.5
	U-NII-C		5600	14.5	28	5.0	5.0	5.0	6.3	6.3	6.3
	U-NII-3		5800	14.5	28	5.0	5.0	5.0	6.2	6.2	6.2
	U-NII-1	802.11n HT20	5200	13.5	22	5.0	5.0	5.0	6.6	6.6	6.6
	U-NII-2A		5300	13.5	22	5.0	5.0	5.0	6.5	6.5	6.5
	U-NII-C		5600	13.5	22	5.0	5.0	5.0	6.3	6.3	6.3
U-NII-3	5800		13.5	22	5.0	5.0	5.0	6.2	6.2	6.2	
Bluetooth	2.0	EDR	2402	1.0	1	5.0	5.0	5.0	9.7	9.7	9.7
Bluetooth	4.0	LE	2402	1.0	1	5.0	5.0	5.0	9.7	9.7	9.7

Notes:

1. The bluetooth don't need be performed the SAR measurement, because the tune-up power is less than the SAR exclusion threshold.

<10-g-SAR Exclusion Calculations for Wi-Fi Antenna < 50mm from the User>

According to KDB 447498 v05 r02 in section 4.3.1:

The 10-g SAR test exclusion thresholds for 100 MHz to 6 GHz at *test separation distances* ≤ 50 mm are determined by:

[Formula]

$$[(\text{max. power of channel, including tune-up tolerance, mW}) / (\text{min. test separation distance, mm})] \cdot$$

$$[\sqrt{f_{(\text{GHz})}}] \leq 7.5 \text{ for 10-g extremity SAR, where}$$

- $f_{(\text{GHz})}$ is the RF channel transmit frequency in GHz
- Power and distance are rounded to the nearest mW and mm before calculation
- The result is rounded to one decimal place for comparison

Antenna	Band	Mode	Frequency (MHz)	Output Power		Separation Distances(mm)			Calculated Threshold Value		
				dBm	mW	Front Face	Rear Face	Left Side	Front Face	Rear Face	Left Side
Wi-Fi Main	2.4GHz	802.11b	2437	17.5	56	5.0	5.0	5.0	24.0	24.0	24.0
	2.4GHz	802.11g	2437	14.5	28	5.0	5.0	5.0	24.0	24.0	24.0
	2.4GHz	802.11n HT20	2437	13.0	20	5.0	5.0	5.0	24.0	24.0	24.0
	U-NII-1	802.11a	5200	14.5	28	5.0	5.0	5.0	16.4	16.4	16.4
	U-NII-2A		5300	14.5	28	5.0	5.0	5.0	16.3	16.3	16.3
	U-NII-C		5600	14.5	28	5.0	5.0	5.0	15.8	15.8	15.8
	U-NII-3		5800	14.5	28	5.0	5.0	5.0	15.6	15.6	15.6
	U-NII-1	802.11n HT20	5200	13.5	22	5.0	5.0	5.0	16.4	16.4	16.4
	U-NII-2A		5300	13.5	22	5.0	5.0	5.0	16.3	16.3	16.3
	U-NII-C		5600	13.5	22	5.0	5.0	5.0	15.8	15.8	15.8
	U-NII-3		5800	13.5	22	5.0	5.0	5.0	15.6	15.6	15.6
	Bluetooth	2.0	EDR	2402	1	1	5.0	5.0	5.0	24.2	24.2
Bluetooth	4.0	LE	2402	1	1	5.0	5.0	5.0	24.2	24.2	24.2

Notes:

1. The bluetooth don't need be performed the SAR measurement, because the tune-up power is less than the SAR exclusion threshold.

12 Antenna Location

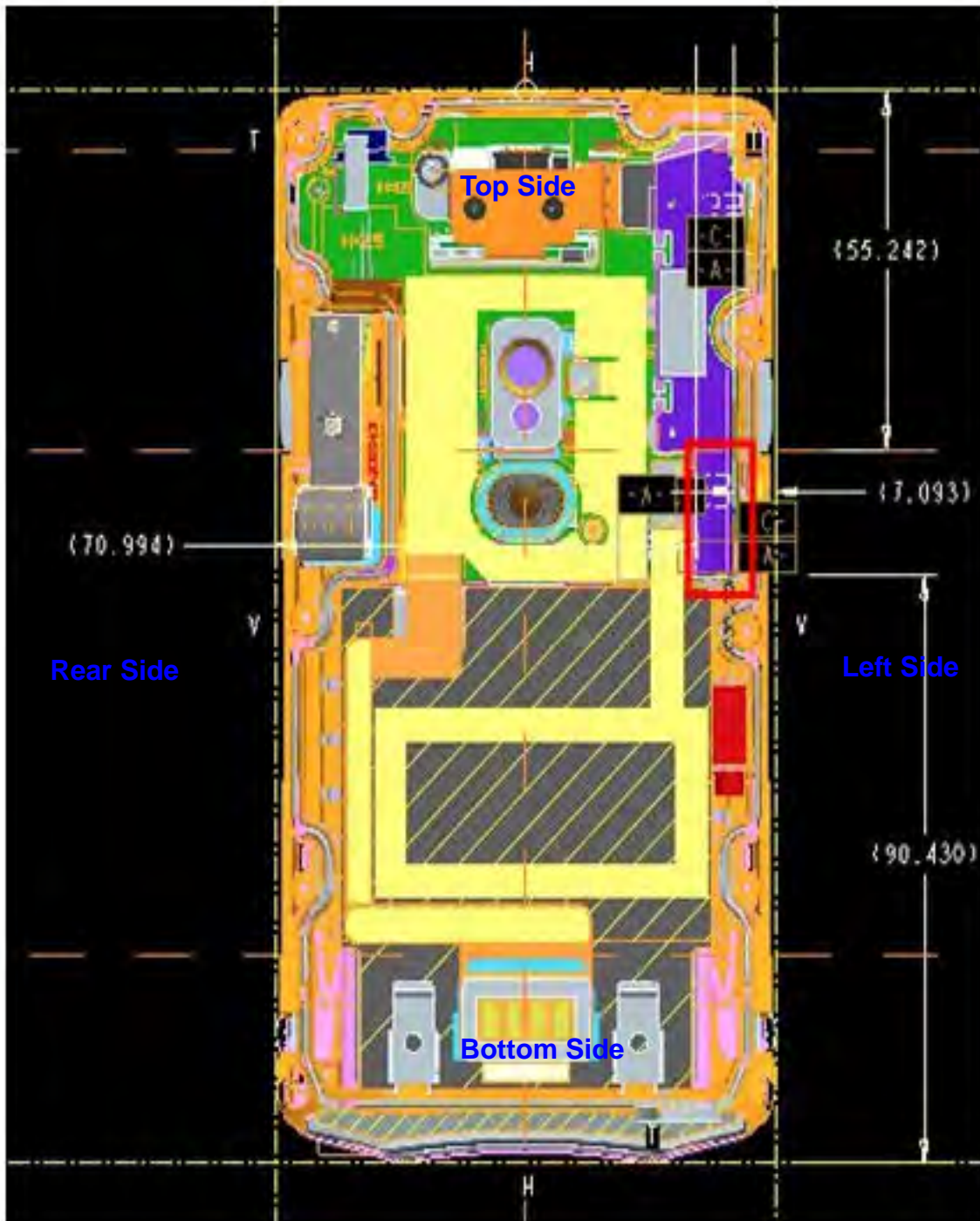

13 SAR Test Results

General Note:

1. Per KDB 447498 D01v05r02, the reported SAR is the measured SAR value adjusted for maximum tune-up tolerance.
 - a. Tune-up scaling Factor = tune-up limit power (mW) / EUT RF power (mW), where tune-up limit is the maximum rated power among all production units.
 - b. For SAR testing of WLAN signal with non-100% duty cycle, the measured SAR is scaled-up by the duty cycle scaling factor which is equal to "1/(duty cycle)"
 - c. For WLAN: Reported SAR(W/kg)= Measured SAR(W/kg)*Tune-up Scaling Factor
2. Per KDB 447498 D01v05r02, for each exposure position, testing of other required channels within the operating mode of a frequency band is not required when the *reported* 1-g or 10-g SAR for the mid-band or highest output power channel is:
 - ≤ 0.8 W/kg or 2.0 W/kg, for 1-g or 10-g respectively, when the transmission band is ≤ 100 MHz
 - ≤ 0.6 W/kg or 1.5 W/kg, for 1-g or 10-g respectively, when the transmission band is between 100 MHz and 200 MHz
 - ≤ 0.4 W/kg or 1.0 W/kg, for 1-g or 10-g respectively, when the transmission band is ≥ 200 MHz
3. When the WLAN transmission was verified using a spectrum analyzer.

13.1 Test Records for Hands SAR Test

<WLAN SAR>

Plot No.	Sample	Band	Test Position	Gap (cm)	Ch.	Freq. (MHz)	Tune-Up Limit (dBm)	Average Power (dBm)	Power Drift (dB)	Measured 1g SAR (W/kg)	Measured 10g SAR (W/kg)	Tune-up Scaling Factor	Reported SAR	
													1g SAR (W/kg)	10g SAR (W/kg)
1	Scan	802.11b	Front Face	0	11	2462	17.5	17.23	-0.04	-	0.045	1.06	-	0.048
2	Scan	802.11b	Rear Face	0	11	2462	17.5	17.23	-0.04	-	0.106	1.06	-	0.113
5	Scan	802.11b	Left Side	0	11	2462	17.5	17.23	0.02	-	0.602	1.06	-	0.641
4	MSR	802.11b	Left Side	0	11	2462	17.5	17.23	0.10	-	0.573	1.06	-	0.610
51	Scan	802.11b	Left Side	1	11	2462	17.5	17.23	-0.10	0.176	-	1.06	0.187	-
10	Scan	802.11a	Front Face	0	40	5200	14.5	14.19	-0.01	-	0.033	1.07	-	0.035
11	Scan	802.11a	Rear Face	0	40	5200	14.5	14.19	-0.12	-	0.139	1.07	-	0.149
12	Scan	802.11a	Left Side	0	40	5200	14.5	14.19	-0.08	-	0.228	1.07	-	0.245
13	MSR	802.11a	Left Side	0	40	5200	14.5	14.19	0.01	-	0.195	1.07	-	0.209
52	Scan	802.11a	Left Side	1	40	5200	14.5	14.19	-0.03	0.206	-	1.07	0.221	-
18	Scan	802.11a	Front Face	0	60	5300	14.5	14.08	0.17	-	0.027	1.10	-	0.030
19	Scan	802.11a	Rear Face	0	60	5300	14.5	14.08	-0.05	-	0.161	1.10	-	0.177
20	Scan	802.11a	Left Side	0	60	5300	14.5	14.08	-0.14	-	0.274	1.10	-	0.302
21	MSR	802.11a	Left Side	0	60	5300	14.5	14.08	-0.10	-	0.199	1.10	-	0.219
53	Scan	802.11a	Left Side	1	60	5300	14.5	14.08	0.05	0.219	-	1.10	0.241	-
26	Scan	802.11a	Front Face	0	100	5500	14.5	14.24	-0.09	-	0.034	1.06	-	0.036
27	Scan	802.11a	Rear Face	0	100	5500	14.5	14.24	-0.02	-	0.115	1.06	-	0.122
28	Scan	802.11a	Left Side	0	100	5500	14.5	14.24	0.06	-	0.222	1.06	-	0.236
29	MSR	802.11a	Left Side	0	100	5500	14.5	14.24	0.01	-	0.231	1.06	-	0.245
54	MSR	802.11a	Left Side	1	100	5500	14.5	14.24	-0.03	0.252	-	1.06	0.268	-
38	Scan	802.11a	Front Face	0	157	5785	14.5	14.24	-0.09	-	0.021	1.06	-	0.022
39	Scan	802.11a	Rear Face	0	157	5785	14.5	14.24	-0.01	-	0.099	1.06	-	0.105
40	Scan	802.11a	Left Side	0	157	5785	14.5	14.24	0.04	-	0.180	1.06	-	0.191
41	MSR	802.11a	Left Side	0	157	5785	14.5	14.24	0.05	-	0.179	1.06	-	0.190
55	Scan	802.11a	Left Side	1	157	5785	14.5	14.24	0	0.214	-	1.06	0.227	-

Note(s):

1. Sample Scan means that it includes the scanner function.
2. Sample MSR means that it doesn't include the scanner function.

14 Simultaneous Transmission SAR Analysis

KDB 447498 D01 General RF Exposure Guidance v05, introduces a new formula for calculating the SAR to Peak Location Ratio (SPLSR) between pairs of simultaneously transmitting antennas:

$$SPLSR = (SAR_1 + SAR_2)^{1.5} / R_i$$

Where:

1. **SAR₁** is the highest Reported or estimated SAR for the first of a pair of simultaneous transmitting antennas, in a specific test operating mode and exposure condition
2. **SAR₂** is the highest Reported or estimated SAR for the second of a pair of simultaneous transmitting antennas, in the same test operating mode and exposure condition as the first
3. **R_i** is the separation distance between the pair of simultaneous transmitting antennas. When the SAR is measured, for both antennas in the pair, it is determined by the actual x, y and z coordinates in the 1-g SAR for each SAR peak location, based on the extrapolated and interpolated result in the zoom scan measurement, using the formula of $[(x_1-x_2)^2 + (y_1-y_2)^2 + (z_1-z_2)^2]$
4. A new threshold of 0.04 is also introduced in the draft KDB. Thus, in order for a pair of simultaneous transmitting antennas with the sum of 1-g SAR > 1.6 W/kg to qualify for exemption from Simultaneous Transmission

$$(SAR_1 + SAR_2)^{1.5} / R_i < 0.04$$



Estimated SAR for Simultaneous Transmission SAR Analysis

Considerations for SAR estimation

1. When standalone SAR test exclusion applies, standalone SAR must also be estimated to determine simultaneous transmission SAR test exclusion.
2. Dedicated Host Approach criteria for SAR test exclusion is likewise applied to SAR estimation, with certain distinctions between test exclusion and SAR estimation:
 - When the separation distance from the antenna to an adjacent edge is ≤ 5 mm, a distance of 5 mm is applied for SAR estimation; this is the same between test exclusion and SAR estimation calculations.
 - When the separation distance from the antenna to an adjacent edge is > 5 mm but ≤ 50 mm, the actual antenna-to-edge separation distance is applied for SAR estimation.
 - When the minimum test separation distance is > 50 mm, the estimated SAR value is 0.4 W/kg

<Estimated SAR>

Antenna	Band	Frequency (MHz)	Output Power		Separation Distances(mm)						Estimated 1-g SAR (W/Kg)					
			dBm	mW	Front Face	Rear Face	Top Side	Left Side	Bottom Side	Right Side	Front Face	Rear Face	Top Side	Left Side	Bottom Side	Right Side
Bluetooth	2.4GHz	2441	1	1	5.0	5.0	50.2	5.0	90.8	70.4	0.07	0.07		0.07		

Antenna	Band	Frequency (MHz)	Output Power		Separation Distances(mm)						Estimated 10-g SAR (W/Kg)					
			dBm	mW	Front Face	Rear Face	Top Side	Left Side	Bottom Side	Right Side	Front Face	Rear Face	Top Side	Left Side	Bottom Side	Right Side
Bluetooth	2.4GHz	2441	1	1	5.0	5.0	50.2	5.0	90.8	70.4	0.03	0.03		0.03		

<Sum of the SAR for Simultaneous Transmission Analysis>

Band	Test Position	Simultaneous Transmission Scenario				∑ 1-g SAR (W/kg)	∑ 10-g SAR (W/kg)	SPLSR (Yes/No)
		WLAN	Bluetooth	WLAN	Bluetooth			
		1g-SAR	1g-SAR	10g-SAR	10g-SAR			
2.4GHz	Front Face			0.048	0.03		0.078	No
	Rear Face			0.113	0.03		0.143	No
	Left Side	0.187	0.070	0.641	0.03	0.257	0.671	No
5.2GHz	Front Face			0.035	0.03		0.065	No
	Rear Face			0.149	0.03		0.179	No
	Left Side	0.221	0.070	0.245	0.03	0.291	0.275	No
5.3GHz	Front Face			0.030	0.03		0.060	No
	Rear Face			0.177	0.03		0.207	No
	Left Side	0.241	0.070	0.302	0.03	0.311	0.332	No
5.5GHz	Front Face			0.036	0.03		0.066	No
	Rear Face			0.122	0.03		0.152	No
	Left Side	0.268	0.070	0.236	0.03	0.338	0.266	No
5.8GHz	Front Face			0.022	0.03		0.052	No
	Rear Face			0.105	0.03		0.135	No
	Left Side	0.227	0.070	0.191	0.03	0.297	0.221	No

15 Uncertainty Assessment

The component of uncertainty may generally be categorized according to the methods used to evaluate them. The evaluation of uncertainty by the statistical analysis of a series of observations is termed a Type A evaluation of uncertainty. The evaluation of uncertainty by means other than the statistical analysis of a series of observation is termed a Type B evaluation of uncertainty. Each component of uncertainty, however evaluated, is represented by an estimated standard deviation, termed standard uncertainty, which is determined by the positive square root of the estimated variance.

A Type A evaluation of standard uncertainty may be based on any valid statistical method for treating data. This includes calculating the standard deviation of the mean of a series of independent observations; using the method of least squares to fit a curve to the data in order to estimate the parameter of the curve and their standard deviations; or carrying out an analysis of variance in order to identify and quantify random effects in certain kinds of measurement.

A type B evaluation of standard uncertainty is typically based on scientific judgment using all of the relevant information available. These may include previous measurement data, experience, and knowledge of the behavior and properties of relevant materials and instruments, manufacture's specification, data provided in calibration reports and uncertainties assigned to reference data taken from handbooks. Broadly speaking, the uncertainty is either obtained from an outdoor source or obtained from an assumed distribution, such as the normal distribution, rectangular or triangular distributions indicated in Table 14.1

Uncertainty Distributions	Normal	Rectangular	Triangular	U-Shape
Multi-plying Factor ^(a)	1/k ^(b)	1/√3	1/√6	1/√2

(a) standard uncertainty is determined as the product of the multiplying factor and the estimated range of variations in the measured quantity

(b) κ is the coverage factor

Standard Uncertainty for Assumed Distribution

The combined standard uncertainty of the measurement result represents the estimated standard deviation of the result. It is obtained by combining the individual standard uncertainties of both Type A and Type B evaluation using the usual "root-sum-squares" (RSS) methods of combining standard deviations by taking the positive square root of the estimated variances.

Expanded uncertainty is a measure of uncertainty that defines an interval about the measurement result within which the measured value is confidently believed to lie. It is obtained by multiplying the combined standard uncertainty by a coverage factor. Typically, the coverage factor ranges from 2 to 3. Using a coverage factor allows the true value of a measured quantity to be specified with a defined probability within the specified uncertainty range. For purpose of this document, a coverage factor two is used, which corresponds to confidence interval of about 95 %. The DASY uncertainty Budget is shown in the following tables.



Error Description	Uncertainty Value (±%)	Probability Distribution	Divisor	Ci (1g)	Standard Uncertainty (±%) (1g)
Measurement System					
Probe Calibration	6.0	Normal	1.0	1.0	6.0
Axial Isotropy	4.7	Rectangular	$\sqrt{3}$	0.7	1.9
Hemispherical Isotropy	9.6	Rectangular	$\sqrt{3}$	0.7	3.9
Boundary effects	1.0	Rectangular	$\sqrt{3}$	1.0	0.6
Linearity	4.7	Rectangular	$\sqrt{3}$	1.0	2.7
System Detection Limits	1.0	Rectangular	$\sqrt{3}$	1.0	0.6
Modulation Response	2.4	Rectangular	$\sqrt{3}$	1.0	1.4
Readout Electronics	0.3	Normal	1.0	1.0	0.3
Response Time	0.8	Rectangular	$\sqrt{3}$	1.0	0.5
Integration Time	2.6	Rectangular	$\sqrt{3}$	1.0	1.5
RF Ambient Noise	3.0	Rectangular	$\sqrt{3}$	1.0	1.7
RF Ambient Reflections	3.0	Rectangular	$\sqrt{3}$	1.0	1.7
Probe Positioner	0.4	Rectangular	$\sqrt{3}$	1.0	0.2
Probe Positioning	2.9	Rectangular	$\sqrt{3}$	1.0	1.7
Max. SAR Eval.	2.0	Rectangular	$\sqrt{3}$	1.0	1.2
Dipole Related					
Device Positioning	2.9	Normal	1.0	1.0	2.9
Device Holder	3.6	Normal	1.0	1.0	3.6
Power Drift	5.0	Rectangular	$\sqrt{3}$	1.0	2.9
Power Scaling	0.0	Rectangular	$\sqrt{3}$	1.0	0.0
Phantom and Tissue parameters					
Phantom Uncertainty	6.1	Rectangular	$\sqrt{3}$	1.0	3.5
SAR correction	1.9	Normal	1.0	1.0	1.9
Liquid Conductivity (measurement)	2.0	Normal	1.0	0.8	1.6
Liquid Permittivity (measurement)	2.1	Normal	1.0	0.3	0.5
Temp. unc. - Conduct	3.4	Rectangular	$\sqrt{3}$	0.8	1.5
Temp. unc. - Permittivity	0.4	Rectangular	$\sqrt{3}$	0.2	0.1
Combined Standard Uncertainty					11.2
Coverage Factor for 95 %					Kp=2
Expanded Uncertainty					22.4

Uncertainty Budget for frequency range 30 MHz to 3 GHz



Error Description	Uncertainty Value (±%)	Probability Distribution	Divisor	Ci (1g)	Standard Uncertainty (±%) (1g)
Measurement System					
Probe Calibration	6.6	Normal	1.0	1.0	6.6
Axial Isotropy	4.7	Rectangular	$\sqrt{3}$	0.7	1.9
Hemispherical Isotropy	9.6	Rectangular	$\sqrt{3}$	0.7	3.9
Boundary effects	2.0	Rectangular	$\sqrt{3}$	1.0	1.2
Linearity	4.7	Rectangular	$\sqrt{3}$	1.0	2.7
System Detection Limits	1.0	Rectangular	$\sqrt{3}$	1.0	0.6
Modulation Response	2.4	Rectangular	$\sqrt{3}$	1.0	1.4
Readout Electronics	0.3	Normal	1.0	1.0	0.3
Response Time	0.8	Rectangular	$\sqrt{3}$	1.0	0.5
Integration Time	2.6	Rectangular	$\sqrt{3}$	1.0	1.5
RF Ambient Noise	3.0	Rectangular	$\sqrt{3}$	1.0	1.7
RF Ambient Reflections	3.0	Rectangular	$\sqrt{3}$	1.0	1.7
Probe Positioner	0.8	Rectangular	$\sqrt{3}$	1.0	0.5
Probe Positioning	6.7	Rectangular	$\sqrt{3}$	1.0	3.9
Max. SAR Eval.	4.0	Rectangular	$\sqrt{3}$	1.0	2.3
Dipole Related					
Device Positioning	2.9	Normal	1.0	1.0	2.9
Device Holder	3.6	Normal	1.0	1.0	3.6
Power Drift	5.0	Rectangular	$\sqrt{3}$	1.0	2.9
Power Scaling	0.0	Rectangular	$\sqrt{3}$	1.0	0.0
Phantom and Tissue parameters					
Phantom Uncertainty	6.6	Rectangular	$\sqrt{3}$	1.0	3.8
SAR correction	1.9	Normal	1.0	1.0	1.9
Liquid Conductivity (measurement)	2.0	Normal	1.0	0.8	1.6
Liquid Permittivity (measurement)	2.1	Normal	1.0	0.3	0.5
Temp. unc. - Conduct	3.4	Rectangular	$\sqrt{3}$	0.8	1.5
Temp. unc. - Permittivity	0.4	Rectangular	$\sqrt{3}$	0.2	0.1
Combined Standard Uncertainty					12.3
Coverage Factor for 95 %					Kp=2
Expanded Uncertainty					24.7

Uncertainty Budget for frequency range 3 GHz to 6 GHz

16 References

- [1] Council Recommendation 1999/519/EC of July 1999 on the limitation of exposure of the general public to electromagnetic fields (0 Hz to 300 GHz)
- [2] EN 50566:2013, "Product standard to demonstrate compliance of radio frequency fields from handheld and body-mounted wireless communication devices used by the general public (30 MHz - 6 GHz)" March 2013.
- [3] EN 62311:2008, "Assessment of electronic and electrical equipment related to human exposure restrictions for electromagnetic fields (0 Hz – 300 GHz)", January 2008
- [4] EN 62209-2:2010, "Human exposure to radio frequency fields from hand-held and body-mounted wireless communication devices. Human models, instrumentation, and procedures. Procedure to determine the specific absorption rate (SAR) for wireless communication devices used in close proximity to the human body (frequency range of 30 MHz to 6 GHz)", August 2010
- [5] EN 62479:2010 "Assessment of the compliance of low power electronic and electrical equipment with the basic restrictions related to human exposure to electromagnetic fields (10 MHz to 300 GHz)", December 2010
- [6] SPEAG DASY System Handbook

System Check_B2450_141125

DUT: Dipole 2450 MHz_SN: 929

Communication System: CW; Frequency: 2450 MHz; Duty Cycle: 1:1

Medium: B2450_141125 Medium parameters used: $f = 2450$ MHz; $\sigma = 2.002$ S/m; $\epsilon_r = 51.299$; $\rho = 1000$ kg/m³

Ambient Temperature : 22.9 °C; Liquid Temperature : 22.7 °C

DASY5 Configuration:

- Probe: EX3DV4 - SN3976; ConvF(7.4, 7.4, 7.4); Calibrated: 2014/2/17;
- Sensor-Surface: 2mm (Mechanical Surface Detection)
- Electronics: DAE4 Sn1424; Calibrated: 2014/2/11
- Phantom: ELI v5.0; Type: QDOVA002AA; Serial: TP:1238
- Measurement SW: DASY52, Version 52.8 (8); SEMCAD X Version 14.6.10 (7331)

Pin=250mW/Area Scan (81x81x1): Interpolated grid: dx=1.200 mm, dy=1.200 mm

Maximum value of SAR (interpolated) = 18.6 W/kg

Pin=250mW/Zoom Scan (7x7x7)/Cube 0: Measurement grid: dx=5mm, dy=5mm, dz=5mm

Reference Value = 97.58 V/m; Power Drift = -0.04 dB

Peak SAR (extrapolated) = 25.4 W/kg

SAR(1 g) = 12.1 W/kg; SAR(10 g) = 5.55 W/kg

Maximum value of SAR (measured) = 18.7 W/kg

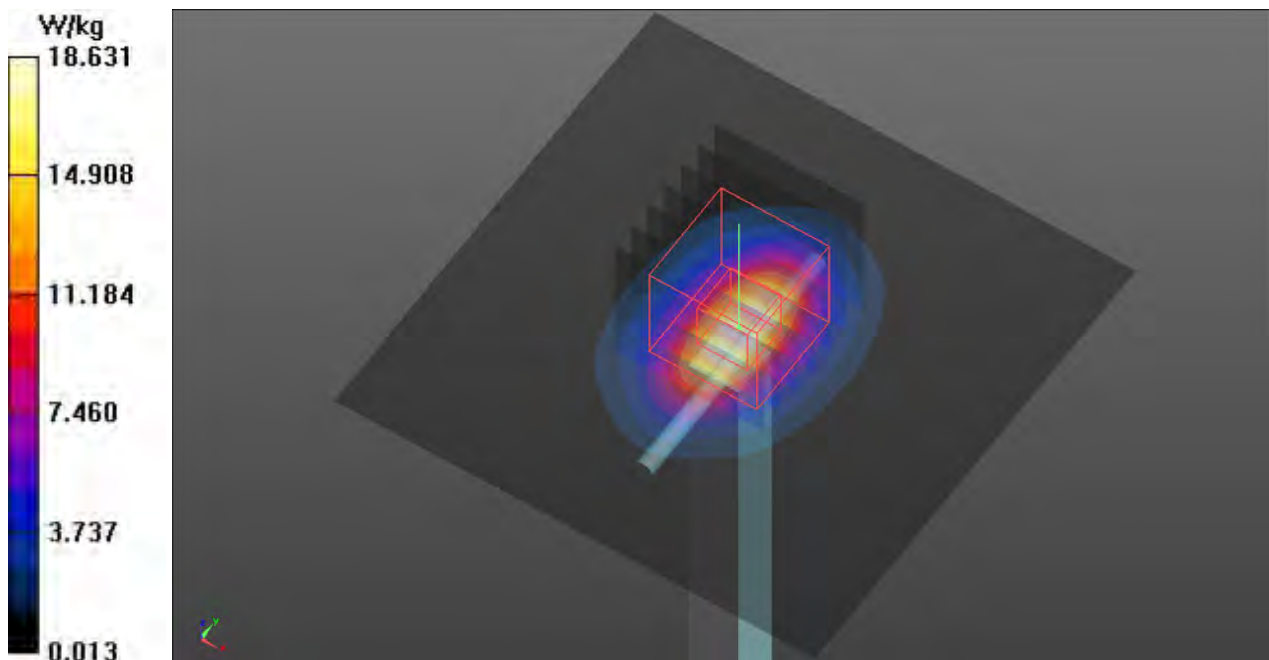

System Check_B2450_141202

DUT: Dipole 2450 MHz_SN: 929

Communication System: CW; Frequency: 2450 MHz; Duty Cycle: 1:1

Medium: B2450_141202 Medium parameters used: $f = 2450$ MHz; $\sigma = 1.999$ S/m; $\epsilon_r = 51.348$; $\rho = 1000$ kg/m³

Ambient Temperature : 23.1 °C; **Liquid Temperature** : 22.9 °C

DASY5 Configuration:

- Probe: EX3DV4 - SN3976; ConvF(7.4, 7.4, 7.4); Calibrated: 2014/2/17;
- Sensor-Surface: 2mm (Mechanical Surface Detection)
- Electronics: DAE4 Sn1424; Calibrated: 2014/2/11
- Phantom: ELI v5.0; Type: QDOVA002AA; Serial: TP:1238
- Measurement SW: DASY52, Version 52.8 (8); SEMCAD X Version 14.6.10 (7331)

Pin=250mW/Area Scan (81x81x1): Interpolated grid: dx=1.200 mm, dy=1.200 mm

Maximum value of SAR (interpolated) = 18.4 W/kg

Pin=250mW/Zoom Scan (7x7x7)/Cube 0: Measurement grid: dx=5mm, dy=5mm, dz=5mm

Reference Value = 96.48 V/m; Power Drift = -0.01 dB

Peak SAR (extrapolated) = 24.9 W/kg

SAR(1 g) = 11.9 W/kg; SAR(10 g) = 5.5 W/kg

Maximum value of SAR (measured) = 18.4 W/kg

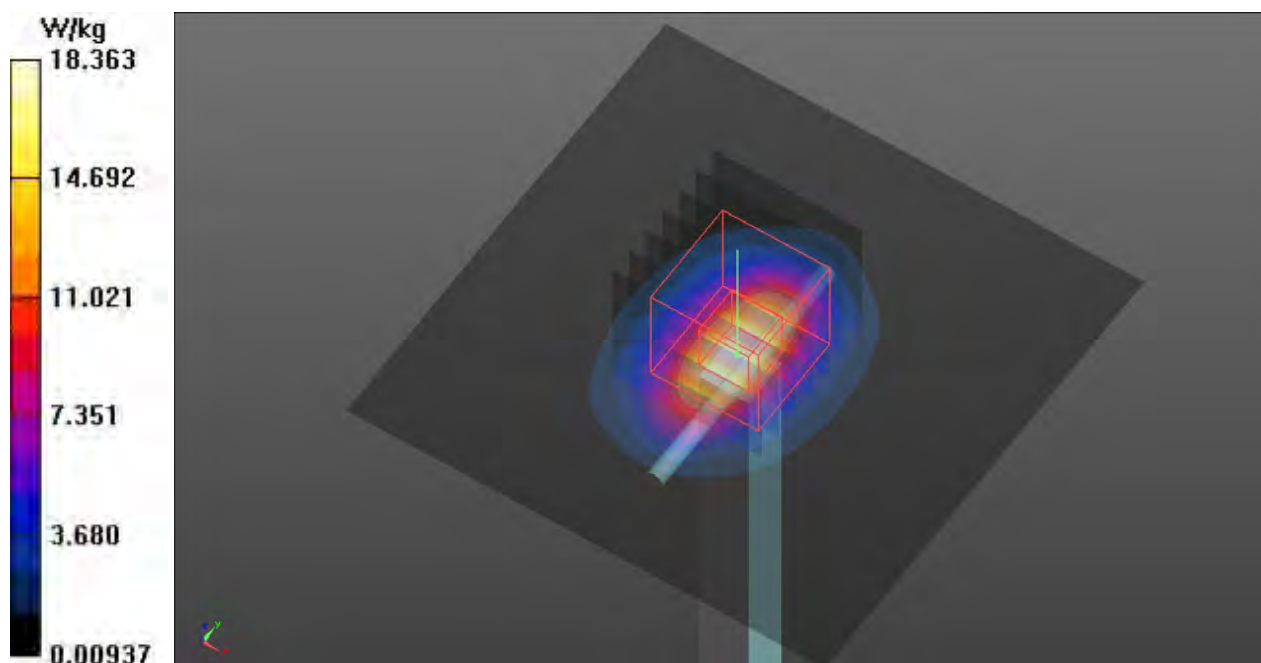

System Check_B2450_141208

DUT: Dipole 2450 MHz_SN: 929

Communication System: CW; Frequency: 2450 MHz; Duty Cycle: 1:1

Medium: B2450_141208 Medium parameters used: $f = 2450$ MHz; $\sigma = 1.997$ S/m; $\epsilon_r = 51.352$; $\rho = 1000$ kg/m³

Ambient Temperature : 23.3 °C; Liquid Temperature : 22.9 °C

DASY5 Configuration:

- Probe: EX3DV4 - SN3976; ConvF(7.4, 7.4, 7.4); Calibrated: 2014/2/17;
- Sensor-Surface: 2mm (Mechanical Surface Detection)
- Electronics: DAE4 Sn1424; Calibrated: 2014/2/11
- Phantom: ELI v5.0; Type: QDOVA002AA; Serial: TP:1238
- Measurement SW: DASY52, Version 52.8 (8); SEMCAD X Version 14.6.10 (7331)

Pin=250mW/Area Scan (81x81x1): Interpolated grid: dx=1.200 mm, dy=1.200 mm

Maximum value of SAR (interpolated) = 18.4 W/kg

Pin=250mW/Zoom Scan (7x7x7)/Cube 0: Measurement grid: dx=5mm, dy=5mm, dz=5mm

Reference Value = 96.48 V/m; Power Drift = -0.01 dB

Peak SAR (extrapolated) = 24.9 W/kg

SAR(1 g) = 11.8 W/kg; SAR(10 g) = 5.8 W/kg

Maximum value of SAR (measured) = 18.4 W/kg

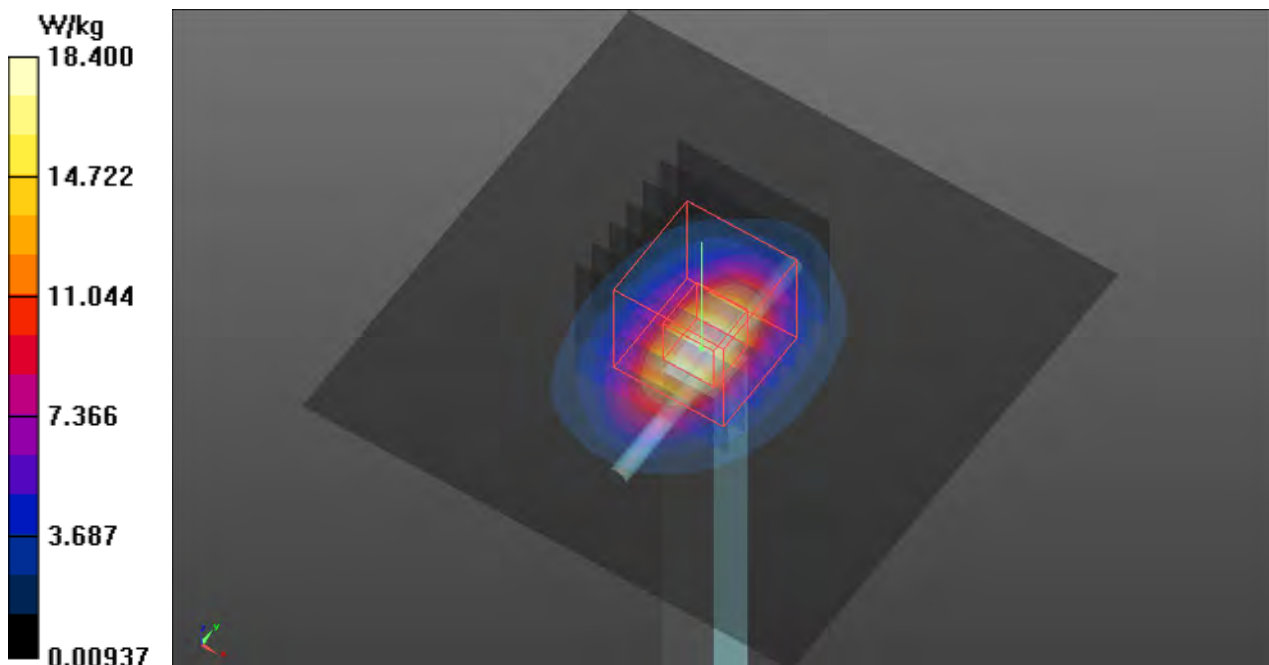

System Check_B5200_141203

DUT: Dipole 5 GHz_SN: 1171

Communication System: CW; Frequency: 5200 MHz; Duty Cycle: 1:1

Medium: B5G_141203 Medium parameters used: $f = 5200$ MHz; $\sigma = 5.288$ S/m; $\epsilon_r = 47.486$; $\rho = 1000$ kg/m³

Ambient Temperature : 23.1 °C; Liquid Temperature : 22.8 °C

DASY5 Configuration:

- Probe: EX3DV4 - SN3976; ConvF(4.61, 4.61, 4.61); Calibrated: 2014/2/17;
- Sensor-Surface: 2mm (Mechanical Surface Detection)
- Electronics: DAE4 Sn1424; Calibrated: 2014/2/11
- Phantom: ELI v5.0; Type: QDOVA002AA; Serial: TP:1238
- Measurement SW: DASY52, Version 52.8 (8); SEMCAD X Version 14.6.10 (7331)

Pin=100mW/Area Scan (91x91x1): Interpolated grid: dx=1.000 mm, dy=1.000 mm

Maximum value of SAR (interpolated) = 14.3 W/kg

Pin=100mW/Zoom Scan (7x7x12)/Cube 0: Measurement grid: dx=4mm, dy=4mm, dz=2mm

Reference Value = 57.38 V/m; Power Drift = 0.04 dB

Peak SAR (extrapolated) = 30.4 W/kg

SAR(1 g) = 7.26 W/kg; SAR(10 g) = 2.06 W/kg

Maximum value of SAR (measured) = 15.3 W/kg

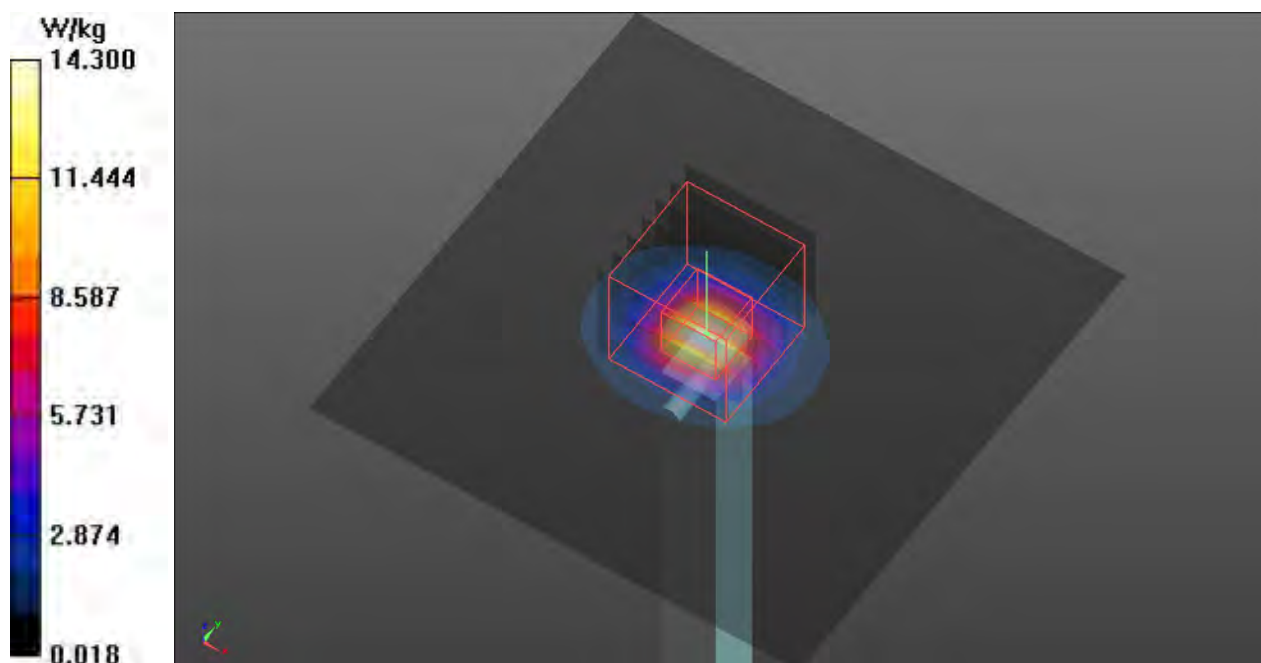

System Check_B5200_141208

DUT: Dipole 5 GHz_SN: 1171

Communication System: CW; Frequency: 5200 MHz; Duty Cycle: 1:1

Medium: B5G_141208 Medium parameters used: $f = 5200$ MHz; $\sigma = 5.296$ S/m; $\epsilon_r = 47.633$; $\rho = 1000$ kg/m³

Ambient Temperature : 23.2 °C; Liquid Temperature : 22.9 °C

DASY5 Configuration:

- Probe: EX3DV4 - SN3976; ConvF(4.61, 4.61, 4.61); Calibrated: 2014/2/17;
- Sensor-Surface: 2mm (Mechanical Surface Detection)
- Electronics: DAE4 Sn1424; Calibrated: 2014/2/11
- Phantom: ELI v5.0; Type: QDOVA002AA; Serial: TP:1238
- Measurement SW: DASY52, Version 52.8 (8); SEMCAD X Version 14.6.10 (7331)

Pin=100mW/Area Scan (91x91x1): Interpolated grid: dx=1.000 mm, dy=1.000 mm

Maximum value of SAR (interpolated) = 14.9 W/kg

Pin=100mW/Zoom Scan (7x7x12)/Cube 0: Measurement grid: dx=4mm, dy=4mm, dz=2mm

Reference Value = 58.04 V/m; Power Drift = 0.04 dB

Peak SAR (extrapolated) = 28.5 W/kg

SAR(1 g) = 7.19 W/kg; SAR(10 g) = 2.03 W/kg

Maximum value of SAR (measured) = 15.1 W/kg

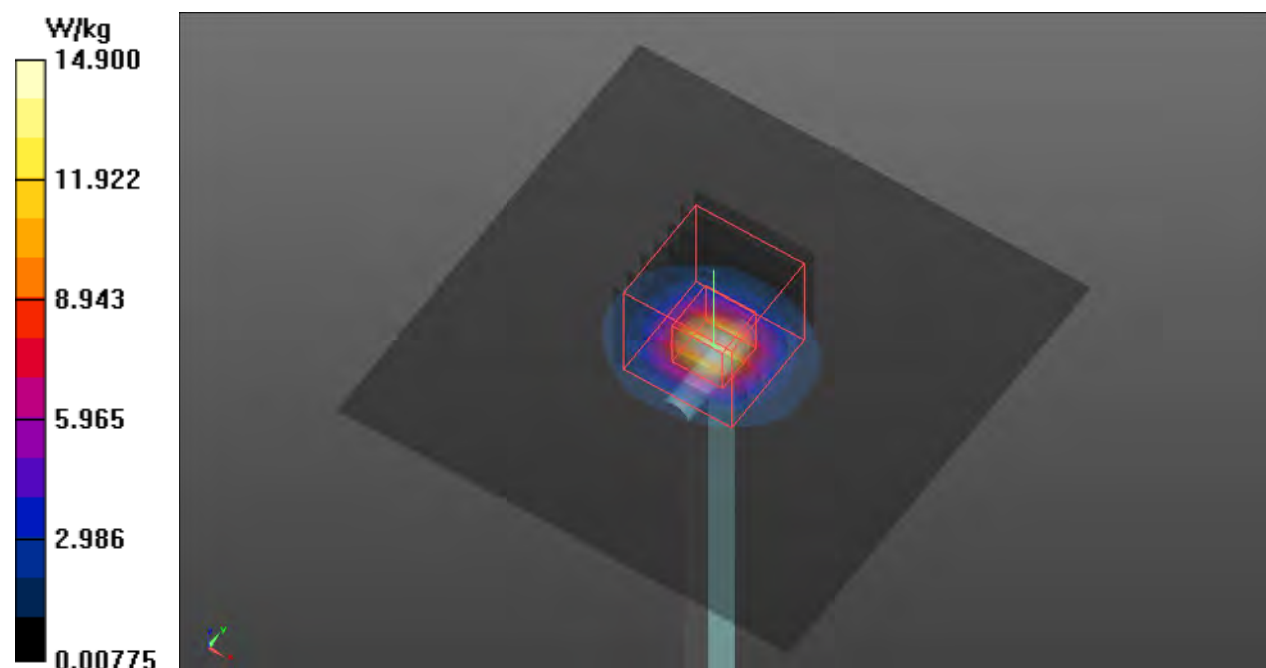

System Check_B5300_141203

DUT: Dipole 5 GHz_SN: 1171

Communication System: CW; Frequency: 5300 MHz; Duty Cycle: 1:1

Medium: B5G_141203 Medium parameters used: $f = 5300$ MHz; $\sigma = 5.416$ S/m; $\epsilon_r = 47.311$; $\rho = 1000$ kg/m³

Ambient Temperature : 23.1 °C; Liquid Temperature : 22.8 °C

DASY5 Configuration:

- Probe: EX3DV4 - SN3976; ConvF(4.39, 4.39, 4.39); Calibrated: 2014/2/17;
- Sensor-Surface: 2mm (Mechanical Surface Detection)
- Electronics: DAE4 Sn1424; Calibrated: 2014/2/11
- Phantom: ELI v5.0; Type: QDOVA002AA; Serial: TP:1238
- Measurement SW: DASY52, Version 52.8 (8); SEMCAD X Version 14.6.10 (7331)

Pin=100mW/Area Scan (91x91x1): Interpolated grid: dx=1.000 mm, dy=1.000 mm

Maximum value of SAR (interpolated) = 14.9 W/kg

Pin=100mW/Zoom Scan (7x7x12)/Cube 0: Measurement grid: dx=4mm, dy=4mm, dz=2mm

Reference Value = 57.43 V/m; Power Drift = 0.02 dB

Peak SAR (extrapolated) = 31.9 W/kg

SAR(1 g) = 7.53 W/kg; SAR(10 g) = 2.12 W/kg

Maximum value of SAR (measured) = 15.8 W/kg

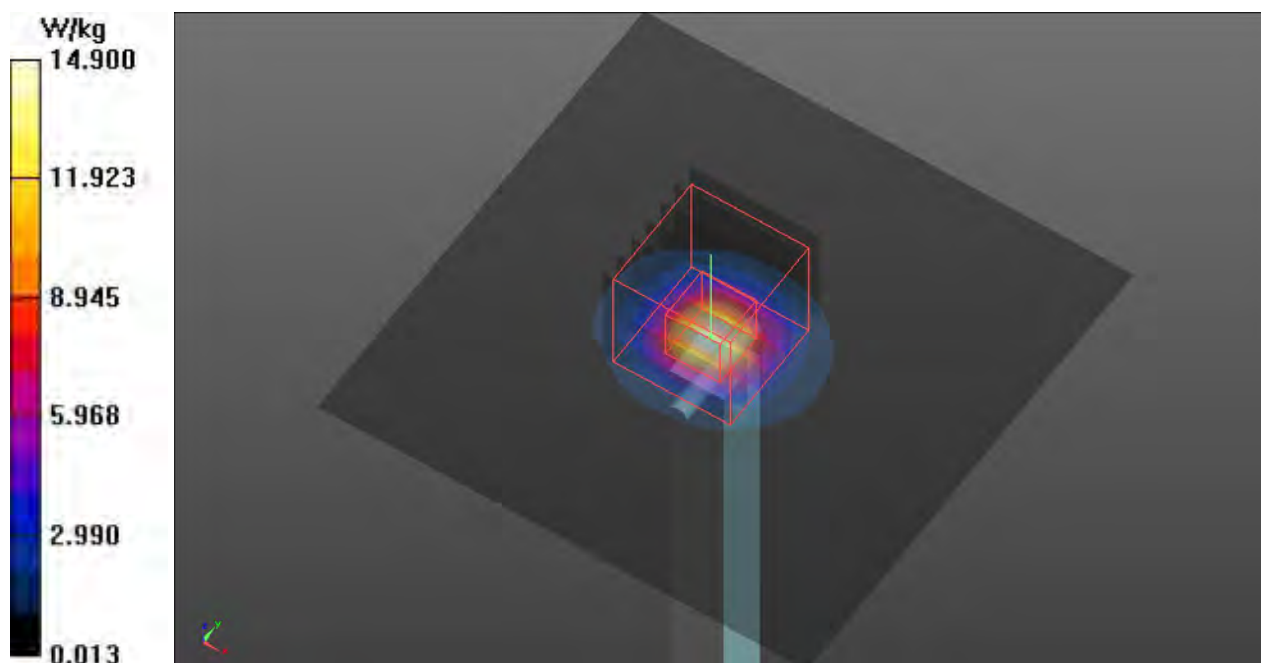

System Check_B5300_141208

DUT: Dipole 5 GHz_SN: 1171

Communication System: CW; Frequency: 5300 MHz; Duty Cycle: 1:1

Medium: B5G_141208 Medium parameters used: $f = 5300$ MHz; $\sigma = 5.424$ S/m; $\epsilon_r = 47.459$; $\rho = 1000$ kg/m³

Ambient Temperature : 23.2 °C; Liquid Temperature : 22.9 °C

DASY5 Configuration:

- Probe: EX3DV4 - SN3976; ConvF(4.39, 4.39, 4.39); Calibrated: 2014/2/17;
- Sensor-Surface: 2mm (Mechanical Surface Detection)
- Electronics: DAE4 Sn1424; Calibrated: 2014/2/11
- Phantom: ELI v5.0; Type: QDOVA002AA; Serial: TP:1238
- Measurement SW: DASY52, Version 52.8 (8); SEMCAD X Version 14.6.10 (7331)

Pin=100mW/Area Scan (91x91x1): Interpolated grid: dx=1.000 mm, dy=1.000 mm

Maximum value of SAR (interpolated) = 14.7 W/kg

Pin=100mW/Zoom Scan (7x7x12)/Cube 0: Measurement grid: dx=4mm, dy=4mm, dz=2mm

Reference Value = 58.48 V/m; Power Drift = 0.05 dB

Peak SAR (extrapolated) = 30.7 W/kg

SAR(1 g) = 7.43 W/kg; SAR(10 g) = 2.07 W/kg

Maximum value of SAR (measured) = 15.8 W/kg

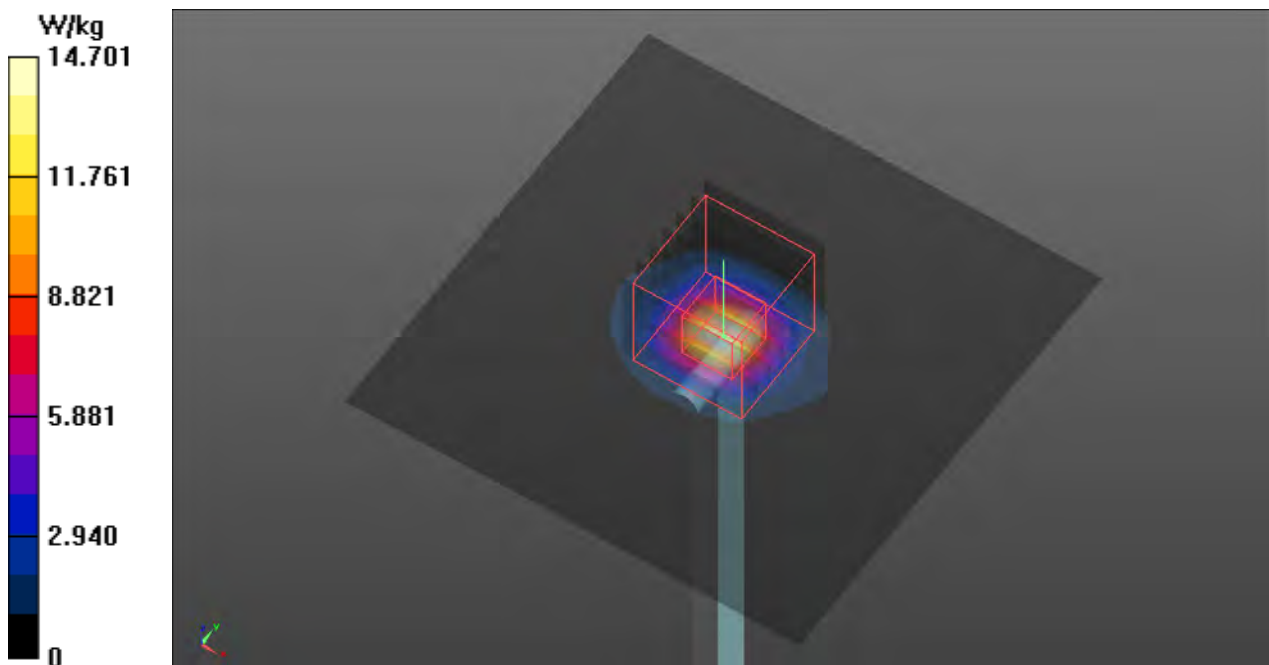

System Check_B5600_141203

DUT: Dipole 5 GHz_SN: 1171

Communication System: CW; Frequency: 5600 MHz; Duty Cycle: 1:1

Medium: B5G_141203 Medium parameters used: $f = 5600$ MHz; $\sigma = 5.817$ S/m; $\epsilon_r = 46.818$; $\rho = 1000$ kg/m³

Ambient Temperature : 23.1 °C; Liquid Temperature : 22.8 °C

DASY5 Configuration:

- Probe: EX3DV4 - SN3976; ConvF(3.69, 3.69, 3.69); Calibrated: 2014/2/17;
- Sensor-Surface: 2mm (Mechanical Surface Detection)
- Electronics: DAE4 Sn1424; Calibrated: 2014/2/11
- Phantom: ELI v5.0; Type: QDOVA002AA; Serial: TP:1238
- Measurement SW: DASY52, Version 52.8 (8); SEMCAD X Version 14.6.10 (7331)

Pin=100mW/Area Scan (91x91x1): Interpolated grid: dx=1.000 mm, dy=1.000 mm

Maximum value of SAR (interpolated) = 15.9 W/kg

Pin=100mW/Zoom Scan (7x7x12)/Cube 0: Measurement grid: dx=4mm, dy=4mm, dz=2mm

Reference Value = 55.96 V/m; Power Drift = 0.09 dB

Peak SAR (extrapolated) = 27.7 W/kg

SAR(1 g) = 7.2 W/kg; SAR(10 g) = 2.04 W/kg

Maximum value of SAR (measured) = 15.1 W/kg

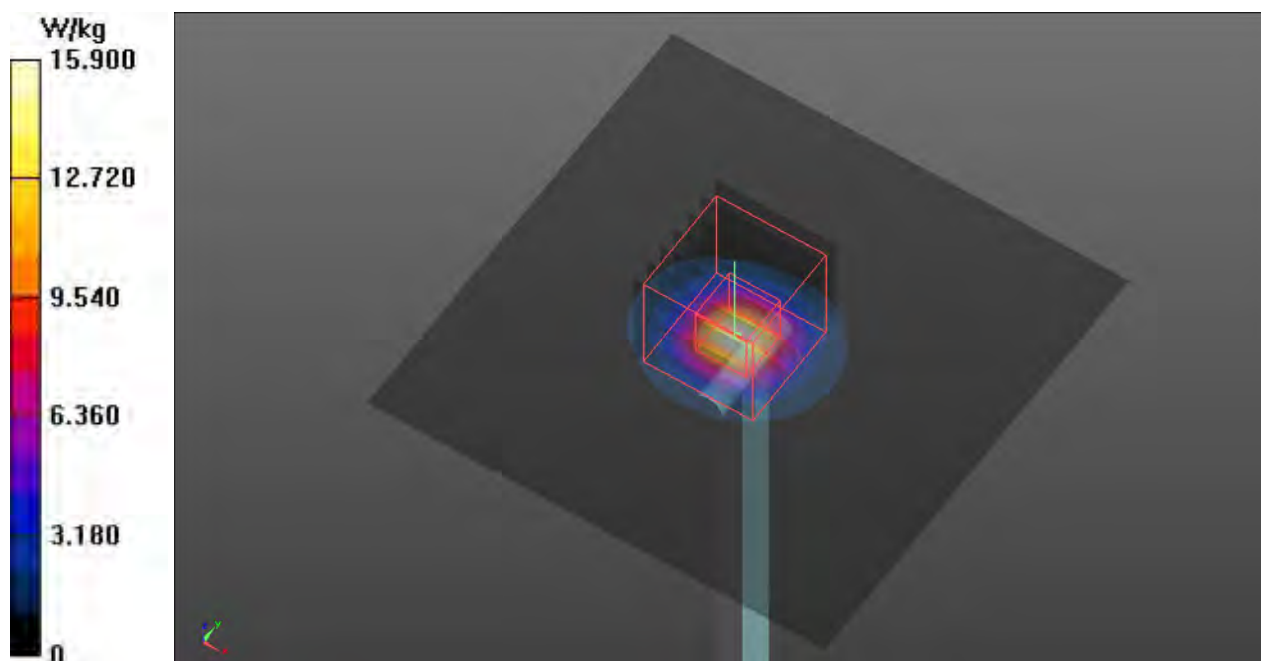

System Check_B5600_141208

DUT: Dipole 5 GHz_SN: 1171

Communication System: CW; Frequency: 5600 MHz; Duty Cycle: 1:1

Medium: B5G_141208 Medium parameters used: $f = 5600$ MHz; $\sigma = 5.827$ S/m; $\epsilon_r = 46.964$; $\rho = 1000$ kg/m³

Ambient Temperature : 23.2 °C; Liquid Temperature : 22.9 °C

DASY5 Configuration:

- Probe: EX3DV4 - SN3976; ConvF(3.69, 3.69, 3.69); Calibrated: 2014/2/17;
- Sensor-Surface: 2mm (Mechanical Surface Detection)
- Electronics: DAE4 Sn1424; Calibrated: 2014/2/11
- Phantom: ELI v5.0; Type: QDOVA002AA; Serial: TP:1238
- Measurement SW: DASY52, Version 52.8 (8); SEMCAD X Version 14.6.10 (7331)

Pin=100mW/Area Scan (91x91x1): Interpolated grid: dx=1.000 mm, dy=1.000 mm

Maximum value of SAR (interpolated) = 16.3 W/kg

Pin=100mW/Zoom Scan (7x7x12)/Cube 0: Measurement grid: dx=4mm, dy=4mm, dz=2mm

Reference Value = 60.61 V/m; Power Drift = -0.02 dB

Peak SAR (extrapolated) = 31.2 W/kg

SAR(1 g) = 7.82 W/kg; SAR(10 g) = 2.19 W/kg

Maximum value of SAR (measured) = 16.7 W/kg

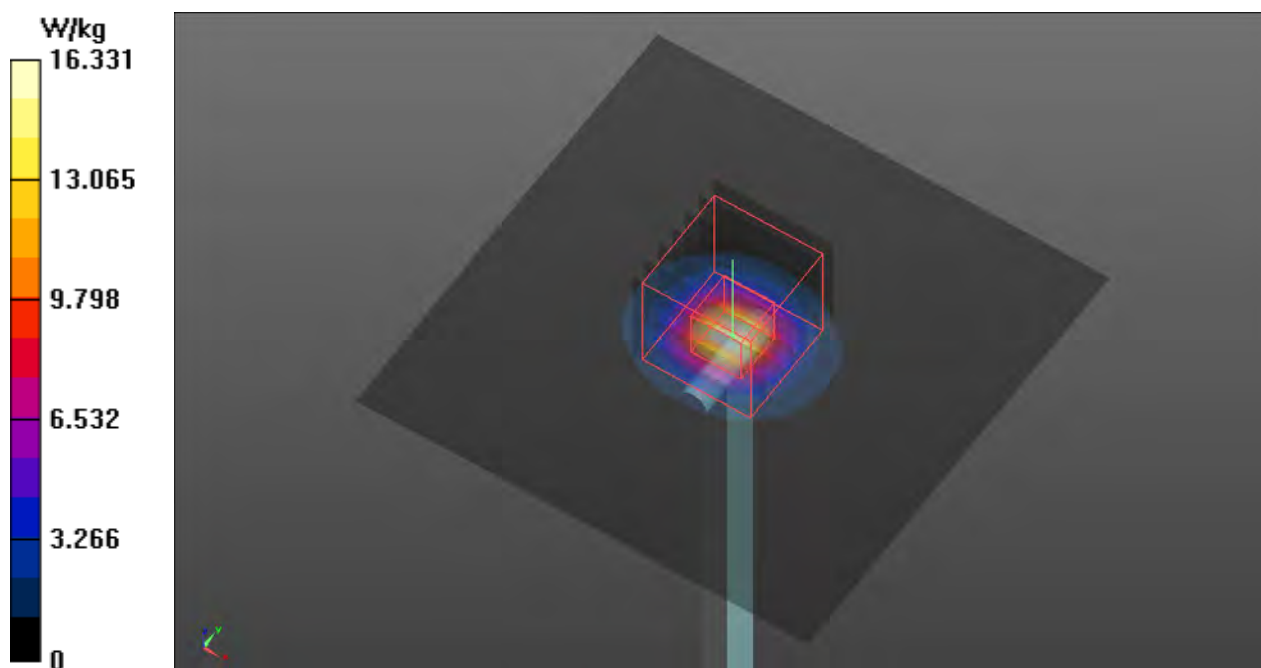

System Check_B5800_141203

DUT: Dipole 5 GHz_SN: 1171

Communication System: CW; Frequency: 5800 MHz; Duty Cycle: 1:1

Medium: B5G_141203 Medium parameters used: $f = 5800$ MHz; $\sigma = 6.089$ S/m; $\epsilon_r = 46.49$; $\rho = 1000$ kg/m³

Ambient Temperature : 23.1 °C; Liquid Temperature : 22.8 °C

DASY5 Configuration:

- Probe: EX3DV4 - SN3976; ConvF(4.26, 4.26, 4.26); Calibrated: 2014/2/17;
- Sensor-Surface: 2mm (Mechanical Surface Detection)
- Electronics: DAE4 Sn1424; Calibrated: 2014/2/11
- Phantom: ELI v5.0; Type: QDOVA002AA; Serial: TP:1238
- Measurement SW: DASY52, Version 52.8 (8); SEMCAD X Version 14.6.10 (7331)

Pin=100mW/Area Scan (91x91x1): Interpolated grid: dx=1.000 mm, dy=1.000 mm

Maximum value of SAR (interpolated) = 14.1 W/kg

Pin=100mW/Zoom Scan (7x7x12)/Cube 0: Measurement grid: dx=4mm, dy=4mm, dz=2mm

Reference Value = 55.38 V/m; Power Drift = -0.03 dB

Peak SAR (extrapolated) = 30.1 W/kg

SAR(1 g) = 7.06 W/kg; SAR(10 g) = 1.99 W/kg

Maximum value of SAR (measured) = 14.9 W/kg

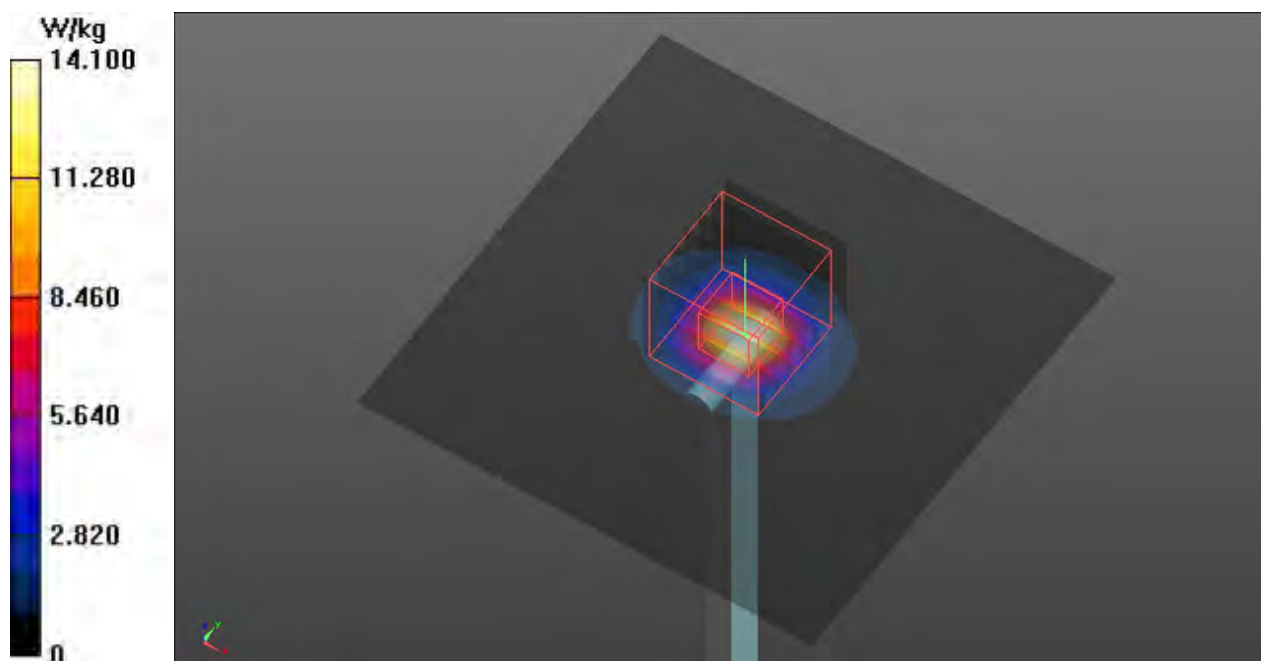

System Check_B5800_141208

DUT: Dipole 5 GHz_SN: 1171

Communication System: CW; Frequency: 5800 MHz; Duty Cycle: 1:1

Medium: B5G_141208 Medium parameters used: $f = 5800$ MHz; $\sigma = 6.098$ S/m; $\epsilon_r = 46.631$; $\rho = 1000$ kg/m³

Ambient Temperature : 23.2 °C; Liquid Temperature : 22.9 °C

DASY5 Configuration:

- Probe: EX3DV4 - SN3976; ConvF(4.26, 4.26, 4.26); Calibrated: 2014/2/17;
- Sensor-Surface: 2mm (Mechanical Surface Detection)
- Electronics: DAE4 Sn1424; Calibrated: 2014/2/11
- Phantom: ELI v5.0; Type: QDOVA002AA; Serial: TP:1238
- Measurement SW: DASY52, Version 52.8 (8); SEMCAD X Version 14.6.10 (7331)

Pin=100mW/Area Scan (91x91x1): Interpolated grid: dx=1.000 mm, dy=1.000 mm

Maximum value of SAR (interpolated) = 13.9 W/kg

Pin=100mW/Zoom Scan (7x7x12)/Cube 0: Measurement grid: dx=4mm, dy=4mm, dz=2mm

Reference Value = 52.52 V/m; Power Drift = 0.02 dB

Peak SAR (extrapolated) = 28.9 W/kg

SAR(1 g) = 6.84 W/kg; SAR(10 g) = 1.92 W/kg

Maximum value of SAR (measured) = 14.7 W/kg

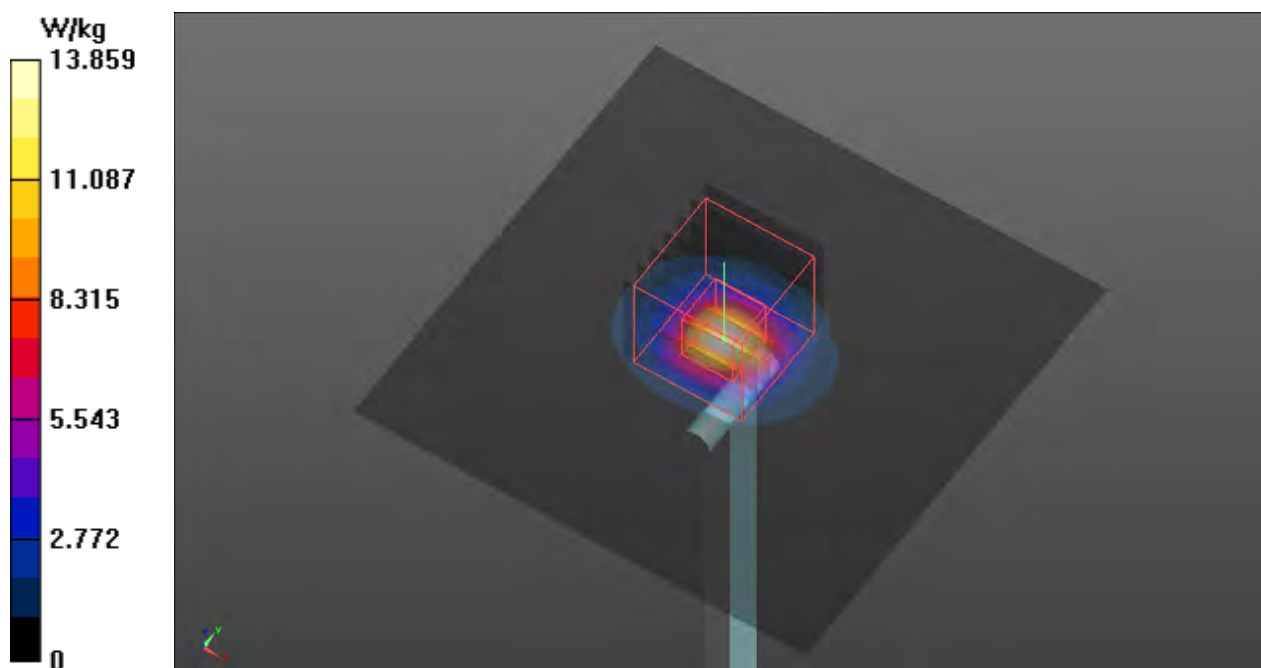

P01 802.11b_Front Face_0cm_Ch11_Scan**DUT: 4N0432-01**

Communication System: WLAN_2.4G; Frequency: 2462 MHz; Duty Cycle: 1:1

Medium: B2450_141202 Medium parameters used: $f = 2462$ MHz; $\sigma = 2.015$ S/m; $\epsilon_r = 51.315$; $\rho = 1000$ kg/m³**Ambient Temperature : 23.1 °C; Liquid Temperature : 22.9 °C**

DASY5 Configuration:

- Probe: EX3DV4 - SN3976; ConvF(7.4, 7.4, 7.4); Calibrated: 2014/2/17;
- Sensor-Surface: 2mm (Mechanical Surface Detection)
- Electronics: DAE4 Sn1424; Calibrated: 2014/2/11
- Phantom: ELI v5.0; Type: QDOVA002AA; Serial: TP:1238
- Measurement SW: DASY52, Version 52.8 (8); SEMCAD X Version 14.6.10 (7331)

Ch11/Area Scan (151x71x1): Interpolated grid: dx=1.200 mm, dy=1.200 mm

Maximum value of SAR (interpolated) = 0.121 W/kg

Ch11/Zoom Scan (5x5x7)/Cube 0: Measurement grid: dx=8mm, dy=8mm, dz=5mm

Reference Value = 7.045 V/m; Power Drift = -0.04 dB

Peak SAR (extrapolated) = 0.206 W/kg

SAR(1 g) = 0.094 W/kg; SAR(10 g) = 0.045 W/kg

Maximum value of SAR (measured) = 0.143 W/kg

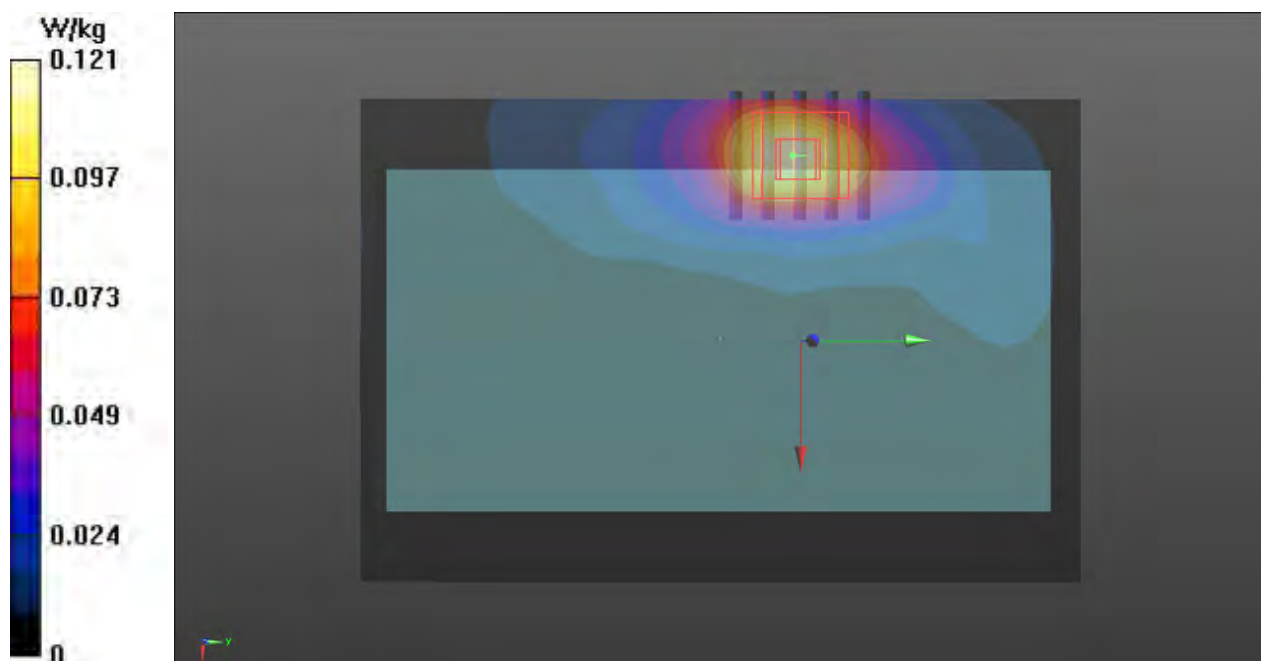

P02 802.11b_Rear Face_0cm_Ch11_Scan

DUT: 4N0432-01

Communication System: WLAN_2.4G; Frequency: 2462 MHz; Duty Cycle: 1:1

Medium: B2450_141202 Medium parameters used: $f = 2462$ MHz; $\sigma = 2.015$ S/m; $\epsilon_r = 51.315$; $\rho = 1000$ kg/m³

Ambient Temperature : 23.1 °C; Liquid Temperature : 22.9 °C

DASY5 Configuration:

- Probe: EX3DV4 - SN3976; ConvF(7.4, 7.4, 7.4); Calibrated: 2014/2/17;
- Sensor-Surface: 2mm (Mechanical Surface Detection)
- Electronics: DAE4 Sn1424; Calibrated: 2014/2/11
- Phantom: ELI v5.0; Type: QDOVA002AA; Serial: TP:1238
- Measurement SW: DASY52, Version 52.8 (8); SEMCAD X Version 14.6.10 (7331)

Ch11/Area Scan (151x71x1): Interpolated grid: dx=1.200 mm, dy=1.200 mm

Maximum value of SAR (interpolated) = 0.257 W/kg

Ch11/Zoom Scan (5x5x7)/Cube 0: Measurement grid: dx=8mm, dy=8mm, dz=5mm

Reference Value = 10.78 V/m; Power Drift = -0.04 dB

Peak SAR (extrapolated) = 0.401 W/kg

SAR(1 g) = 0.199 W/kg; SAR(10 g) = 0.106 W/kg

Maximum value of SAR (measured) = 0.281 W/kg

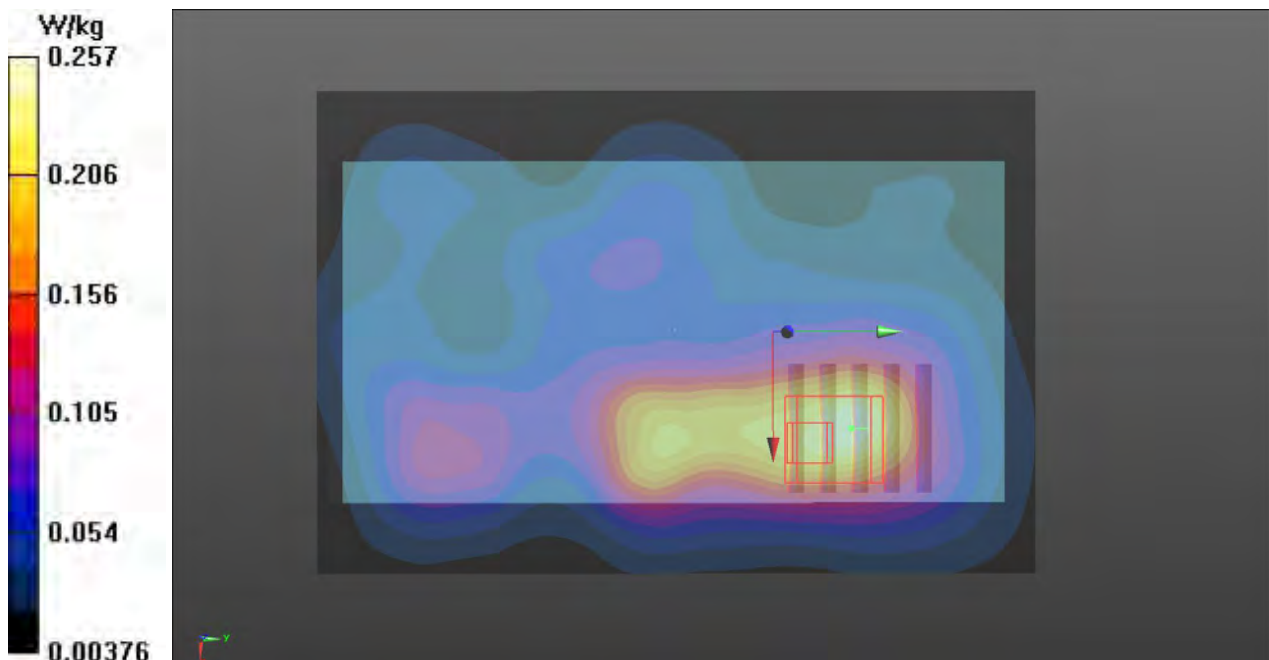

P05 802.11b_Left Side_0cm_Ch11_Scan

DUT: 4N0432-01

Communication System: WLAN_2.4G; Frequency: 2462 MHz; Duty Cycle: 1:1
Medium: B2450_141125 Medium parameters used: $f = 2462$ MHz; $\sigma = 2.018$ S/m; $\epsilon_r = 51.266$; $\rho = 1000$ kg/m³

Ambient Temperature : 22.9 °C; Liquid Temperature : 22.7 °C

DASY5 Configuration:

- Probe: EX3DV4 - SN3976; ConvF(7.4, 7.4, 7.4); Calibrated: 2014/2/17;
- Sensor-Surface: 2mm (Mechanical Surface Detection)
- Electronics: DAE4 Sn1424; Calibrated: 2014/2/11
- Phantom: ELI v5.0; Type: QDOVA002AA; Serial: TP:1238
- Measurement SW: DASY52, Version 52.8 (8); SEMCAD X Version 14.6.10 (7331)

Ch11/Area Scan (151x51x1): Interpolated grid: dx=1.200 mm, dy=1.200 mm

Maximum value of SAR (interpolated) = 1.34 W/kg

Ch11/Zoom Scan (5x5x7)/Cube 0: Measurement grid: dx=8mm, dy=8mm, dz=5mm

Reference Value = 23.58 V/m; Power Drift = 0.02 dB

Peak SAR (extrapolated) = 4.27 W/kg

SAR(1 g) = 1.61 W/kg; SAR(10 g) = 0.602 W/kg

Maximum value of SAR (measured) = 2.96 W/kg

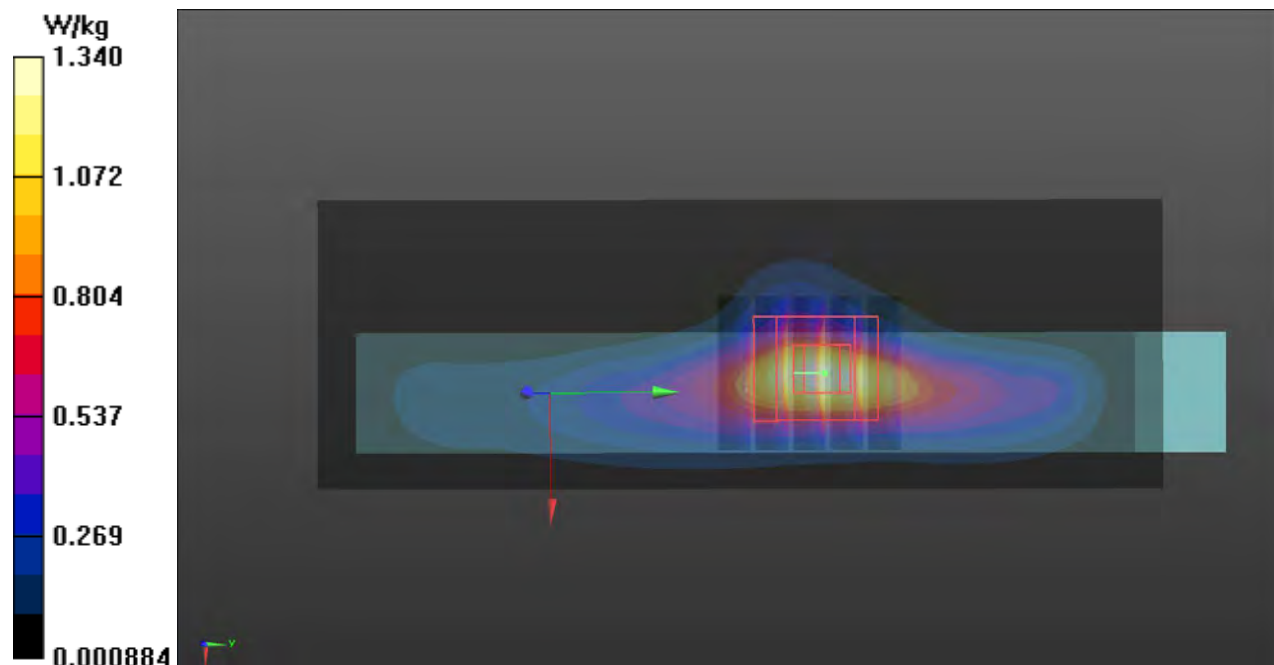

1g/10g Averaged SAR

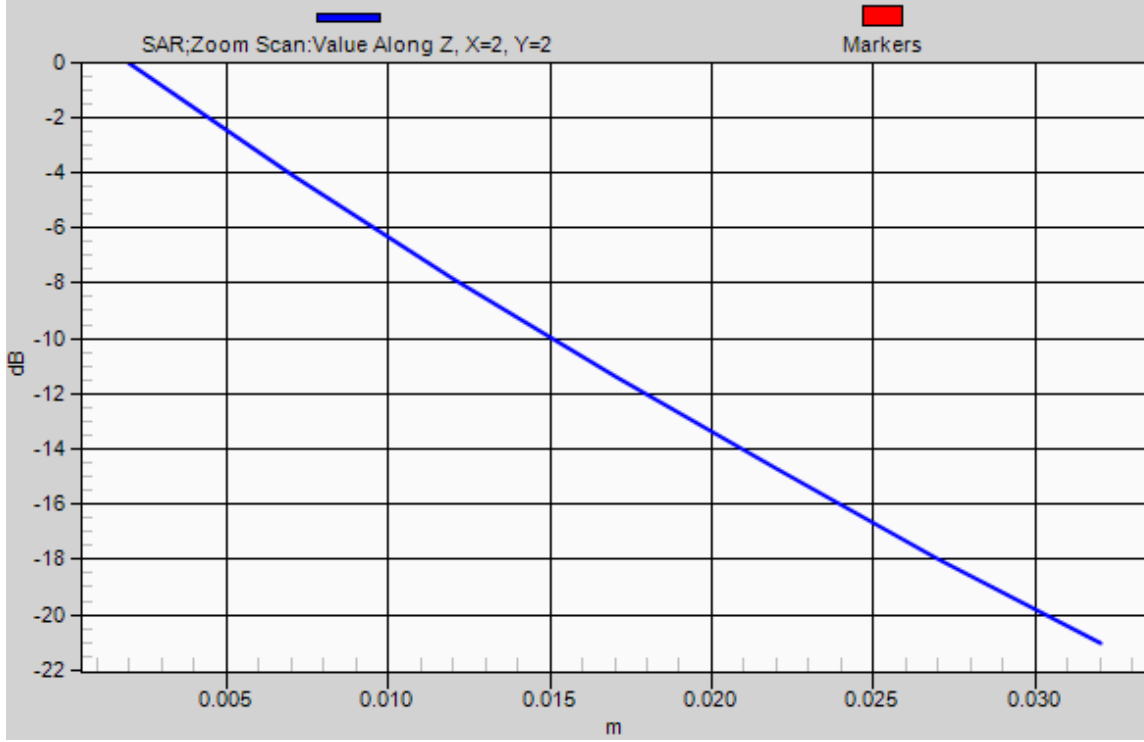

P04 802.11b_Left Side_0cm_Ch11_MSR

DUT: 4N0432-01

Communication System: WLAN_2.4G; Frequency: 2462 MHz; Duty Cycle: 1:1
 Medium: B2450_141125 Medium parameters used: $f = 2462$ MHz; $\sigma = 2.018$ S/m; $\epsilon_r = 51.266$; $\rho = 1000$ kg/m³

Ambient Temperature : 22.9 °C; Liquid Temperature : 22.7 °C

DASY5 Configuration:

- Probe: EX3DV4 - SN3976; ConvF(7.4, 7.4, 7.4); Calibrated: 2014/2/17;
- Sensor-Surface: 2mm (Mechanical Surface Detection)
- Electronics: DAE4 Sn1424; Calibrated: 2014/2/11
- Phantom: ELI v5.0; Type: QDOVA002AA; Serial: TP:1238
- Measurement SW: DASY52, Version 52.8 (8); SEMCAD X Version 14.6.10 (7331)

Ch11/Area Scan (151x71x1): Interpolated grid: dx=1.200 mm, dy=1.200 mm

Maximum value of SAR (interpolated) = 1.36 W/kg

Ch11/Zoom Scan (5x5x7)/Cube 0: Measurement grid: dx=8mm, dy=8mm, dz=5mm

Reference Value = 24.55 V/m; Power Drift = 0.10 dB

Peak SAR (extrapolated) = 3.98 W/kg

SAR(1 g) = 1.52 W/kg; SAR(10 g) = 0.573 W/kg

Maximum value of SAR (measured) = 2.61 W/kg

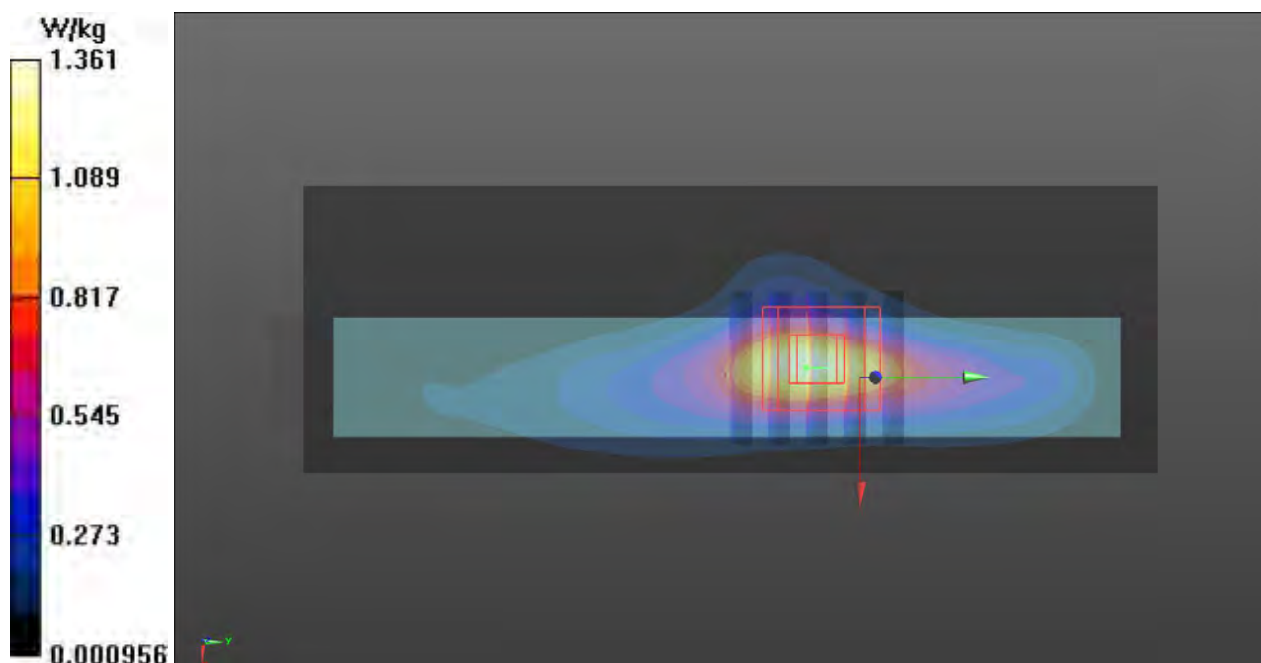

P51 802.11b_Left Side_1cm_Ch11_Scan

DUT: 4N0432-01

Communication System: WLAN_2.4G; Frequency: 2462 MHz; Duty Cycle: 1:1

Medium: B2450_141208 Medium parameters used: $f = 2462$ MHz; $\sigma = 2.015$ S/m; $\epsilon_r = 51.315$; $\rho = 1000$ kg/m³

Ambient Temperature : 23.3 °C; Liquid Temperature : 22.9 °C

DASY5 Configuration:

- Probe: EX3DV4 - SN3976; ConvF(7.4, 7.4, 7.4); Calibrated: 2014/2/17;
- Sensor-Surface: 2mm (Mechanical Surface Detection)
- Electronics: DAE4 Sn1424; Calibrated: 2014/2/11
- Phantom: ELI v5.0; Type: QDOVA002AA; Serial: TP:1238
- Measurement SW: DASY52, Version 52.8 (8); SEMCAD X Version 14.6.10 (7331)

Ch11/Area Scan (51x151x1): Interpolated grid: dx=1.200 mm, dy=1.200 mm

Maximum value of SAR (interpolated) = 0.201 W/kg

Ch11/Zoom Scan (5x5x7)/Cube 0: Measurement grid: dx=8mm, dy=8mm, dz=5mm

Reference Value = 9.454 V/m; Power Drift = -0.10 dB

Peak SAR (extrapolated) = 0.348 W/kg

SAR(1 g) = 0.176 W/kg; SAR(10 g) = 0.090 W/kg

Maximum value of SAR (measured) = 0.250 W/kg

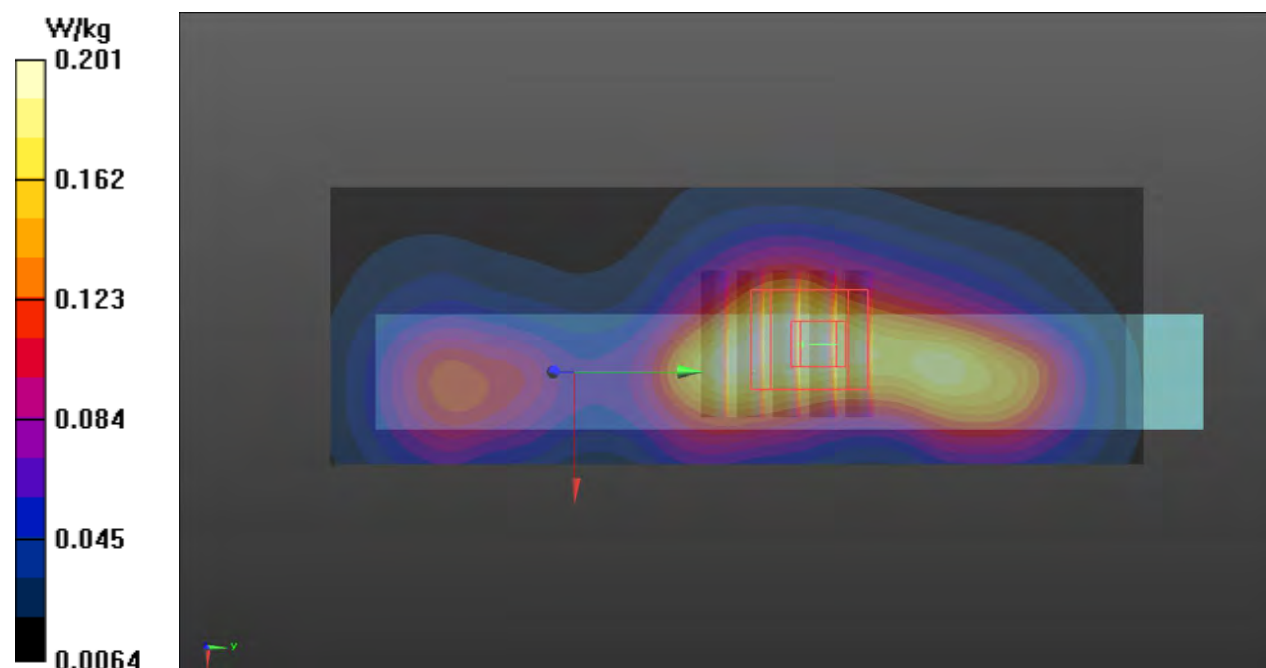

P10 802.11a_Front Face_0cm_Ch40_Scan

DUT: 4N0432-01

Communication System: WLAN_5G; Frequency: 5200 MHz; Duty Cycle: 1:1

Medium: B5G_141203 Medium parameters used: $f = 5200$ MHz; $\sigma = 5.288$ S/m; $\epsilon_r = 47.486$; $\rho = 1000$ kg/m³

Ambient Temperature : 23.1 °C; Liquid Temperature : 22.8 °C

DASY5 Configuration:

- Probe: EX3DV4 - SN3976; ConvF(4.61, 4.61, 4.61); Calibrated: 2014/2/17;
- Sensor-Surface: 2mm (Mechanical Surface Detection)
- Electronics: DAE4 Sn1424; Calibrated: 2014/2/11
- Phantom: ELI v5.0; Type: QDOVA002AA; Serial: TP:1238
- Measurement SW: DASY52, Version 52.8 (8); SEMCAD X Version 14.6.10 (7331)

Ch40/Area Scan (121x181x1): Interpolated grid: dx=1.000 mm, dy=1.000 mm

Maximum value of SAR (interpolated) = 0.257 W/kg

Ch40/Zoom Scan (6x6x12)/Cube 0: Measurement grid: dx=5mm, dy=5mm, dz=2mm

Reference Value = 4.934 V/m; Power Drift = -0.01 dB

Peak SAR (extrapolated) = 0.295 W/kg

SAR(1 g) = 0.079 W/kg; SAR(10 g) = 0.033 W/kg

Maximum value of SAR (measured) = 0.138 W/kg

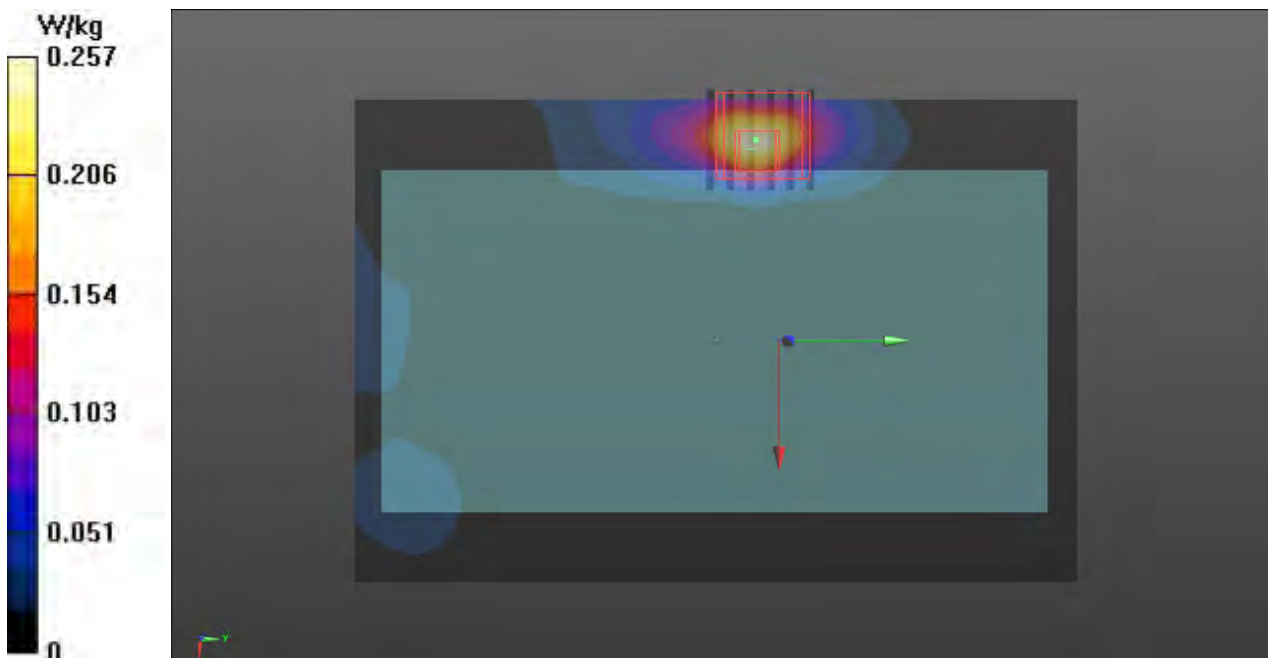

P11 802.11a_Rear Face_0cm_Ch40_Scan**DUT: 4N0432-01**

Communication System: WLAN_5G; Frequency: 5200 MHz; Duty Cycle: 1:1

Medium: B5G_141203 Medium parameters used: $f = 5200$ MHz; $\sigma = 5.288$ S/m; $\epsilon_r = 47.486$; $\rho = 1000$ kg/m³**Ambient Temperature : 23.1 °C; Liquid Temperature : 22.8 °C**

DASY5 Configuration:

- Probe: EX3DV4 - SN3976; ConvF(4.61, 4.61, 4.61); Calibrated: 2014/2/17;
- Sensor-Surface: 2mm (Mechanical Surface Detection)
- Electronics: DAE4 Sn1424; Calibrated: 2014/2/11
- Phantom: ELI v5.0; Type: QDOVA002AA; Serial: TP:1238
- Measurement SW: DASY52, Version 52.8 (8); SEMCAD X Version 14.6.10 (7331)

Ch40/Area Scan (121x181x1): Interpolated grid: dx=1.000 mm, dy=1.000 mm

Maximum value of SAR (interpolated) = 0.750 W/kg

Ch40/Zoom Scan (6x6x12)/Cube 0: Measurement grid: dx=5mm, dy=5mm, dz=2mm

Reference Value = 12.12 V/m; Power Drift = -0.12 dB

Peak SAR (extrapolated) = 1.54 W/kg

SAR(1 g) = 0.377 W/kg; SAR(10 g) = 0.139 W/kg

Maximum value of SAR (measured) = 0.746 W/kg

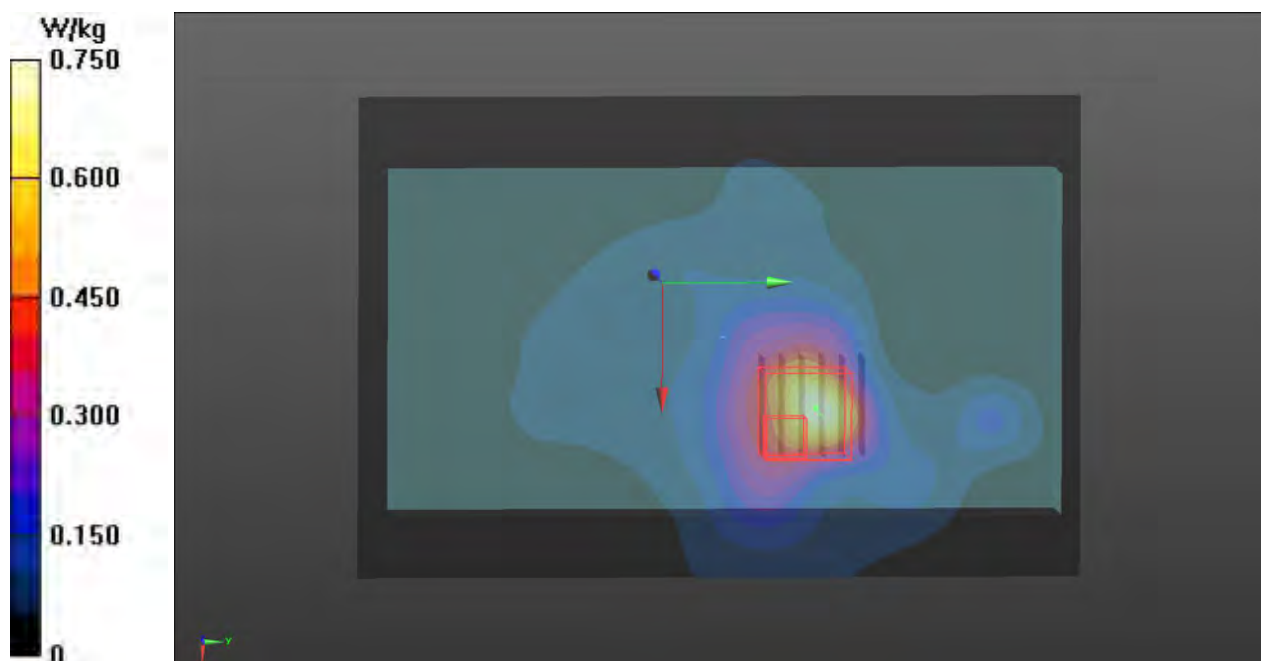

P12 802.11a_Left Side_0cm_Ch40_Scan

DUT: 4N0432-01

Communication System: WLAN_5G; Frequency: 5200 MHz; Duty Cycle: 1:1

Medium: B5G_141203 Medium parameters used: $f = 5200$ MHz; $\sigma = 5.288$ S/m; $\epsilon_r = 47.486$; $\rho = 1000$ kg/m³

Ambient Temperature : 23.1 °C; Liquid Temperature : 22.8 °C

DASY5 Configuration:

- Probe: EX3DV4 - SN3976; ConvF(4.61, 4.61, 4.61); Calibrated: 2014/2/17;
- Sensor-Surface: 2mm (Mechanical Surface Detection)
- Electronics: DAE4 Sn1424; Calibrated: 2014/2/11
- Phantom: ELI v5.0; Type: QDOVA002AA; Serial: TP:1238
- Measurement SW: DASY52, Version 52.8 (8); SEMCAD X Version 14.6.10 (7331)

Ch40/Area Scan (81x181x1): Interpolated grid: dx=1.000 mm, dy=1.000 mm

Maximum value of SAR (interpolated) = 1.31 W/kg

Ch40/Zoom Scan (6x6x12)/Cube 0: Measurement grid: dx=5mm, dy=5mm, dz=2mm

Reference Value = 16.54 V/m; Power Drift = -0.08 dB

Peak SAR (extrapolated) = 3.44 W/kg

SAR(1 g) = 0.783 W/kg; SAR(10 g) = 0.228 W/kg

Maximum value of SAR (measured) = 1.62 W/kg

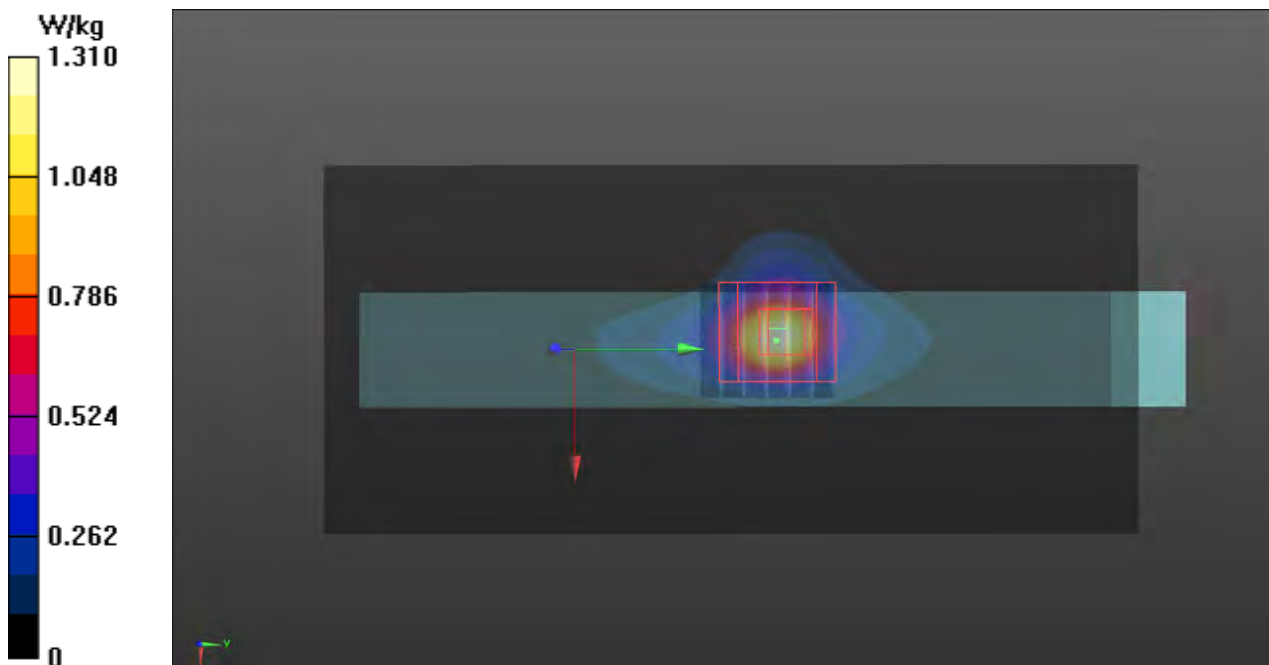

1g/10g Averaged SAR

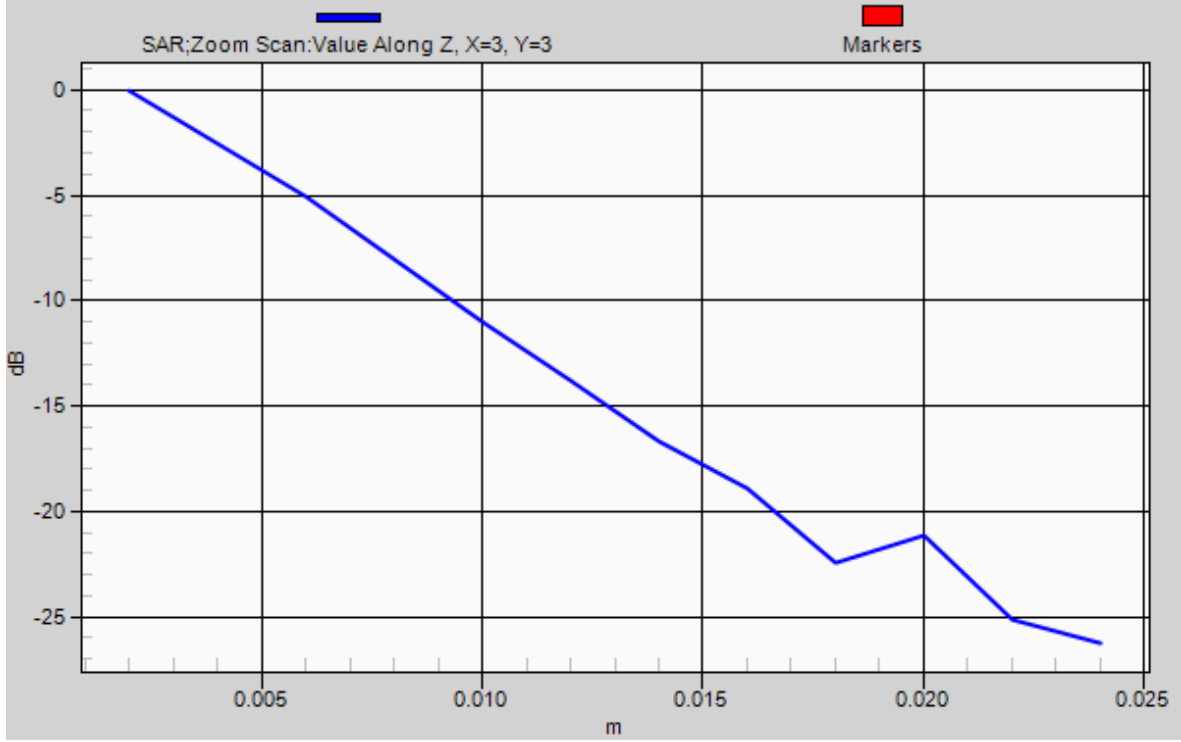

P13 802.11a_Left Side_0cm_Ch40_MSR**DUT: 4N0432-01**

Communication System: WLAN_5G; Frequency: 5200 MHz; Duty Cycle: 1:1

Medium: B5G_141203 Medium parameters used: $f = 5200$ MHz; $\sigma = 5.288$ S/m; $\epsilon_r = 47.486$; $\rho = 1000$ kg/m³**Ambient Temperature : 23.1 °C; Liquid Temperature : 22.8 °C**

DASY5 Configuration:

- Probe: EX3DV4 - SN3976; ConvF(4.61, 4.61, 4.61); Calibrated: 2014/2/17;
- Sensor-Surface: 2mm (Mechanical Surface Detection)
- Electronics: DAE4 Sn1424; Calibrated: 2014/2/11
- Phantom: ELI v5.0; Type: QDOVA002AA; Serial: TP:1238
- Measurement SW: DASY52, Version 52.8 (8); SEMCAD X Version 14.6.10 (7331)

Ch40/Area Scan (61x181x1): Interpolated grid: dx=1.000 mm, dy=1.000 mm

Maximum value of SAR (interpolated) = 1.03 W/kg

Ch40/Zoom Scan (6x6x12)/Cube 0: Measurement grid: dx=5mm, dy=5mm, dz=2mm

Reference Value = 14.43 V/m; Power Drift = 0.01 dB

Peak SAR (extrapolated) = 3.00 W/kg

SAR(1 g) = 0.675 W/kg; SAR(10 g) = 0.195 W/kg

Maximum value of SAR (measured) = 1.36 W/kg

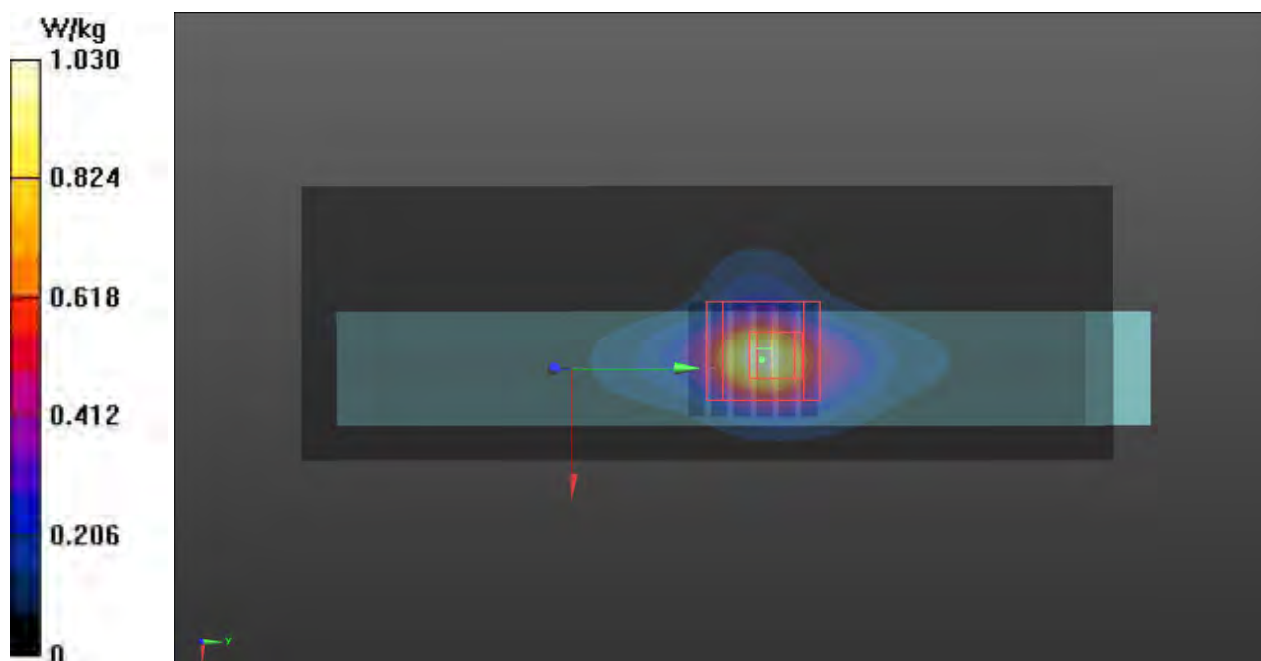

P52 802.11a_Left Side_1cm_Ch40_Scan

DUT: 4N0432-01

Communication System: WLAN_5G; Frequency: 5200 MHz; Duty Cycle: 1:1

Medium: B5G_141208 Medium parameters used: $f = 5200$ MHz; $\sigma = 5.296$ S/m; $\epsilon_r = 47.633$; $\rho = 1000$ kg/m³

Ambient Temperature : 23.2 °C; Liquid Temperature : 22.9 °C

DASY5 Configuration:

- Probe: EX3DV4 - SN3976; ConvF(4.61, 4.61, 4.61); Calibrated: 2014/2/17;
- Sensor-Surface: 2mm (Mechanical Surface Detection)
- Electronics: DAE4 Sn1424; Calibrated: 2014/2/11
- Phantom: ELI v5.0; Type: QDOVA002AA; Serial: TP:1238
- Measurement SW: DASY52, Version 52.8 (8); SEMCAD X Version 14.6.10 (7331)

Ch40/Area Scan (61x181x1): Interpolated grid: dx=1.000 mm, dy=1.000 mm

Maximum value of SAR (interpolated) = 0.321 W/kg

Ch40/Zoom Scan (6x6x12)/Cube 0: Measurement grid: dx=5mm, dy=5mm, dz=2mm

Reference Value = 7.605 V/m; Power Drift = -0.03 dB

Peak SAR (extrapolated) = 0.743 W/kg

SAR(1 g) = 0.206 W/kg; SAR(10 g) = 0.080 W/kg

Maximum value of SAR (measured) = 0.378 W/kg

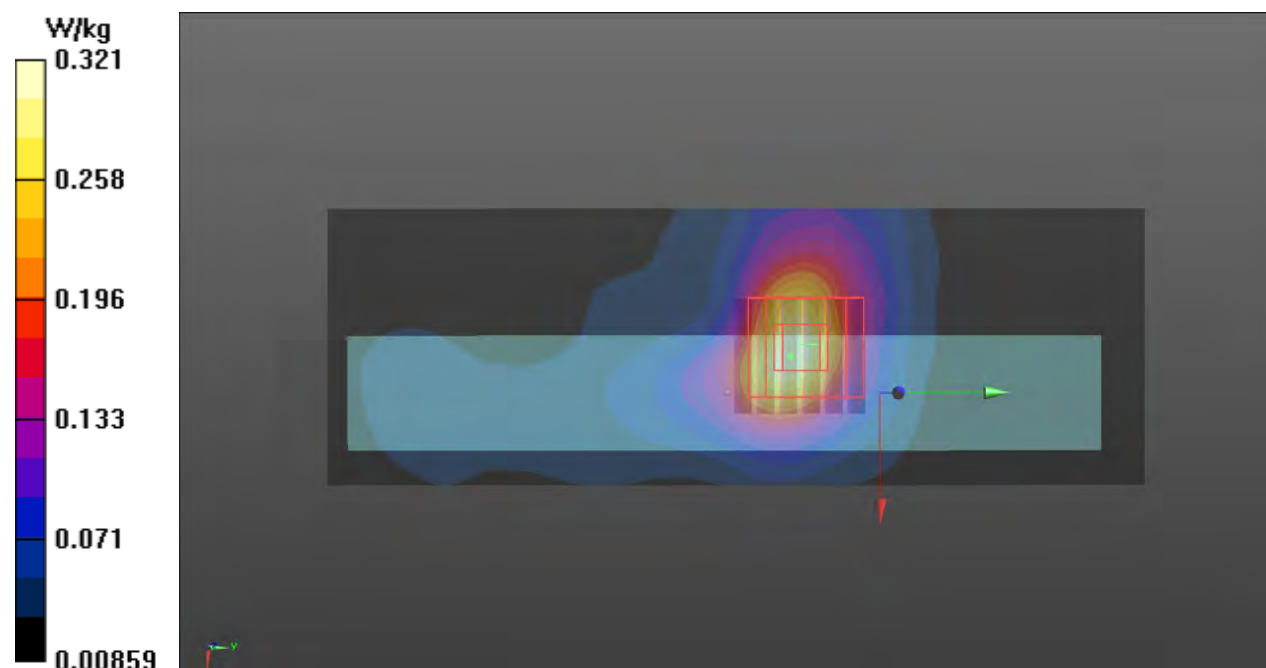

P18 802.11a_Front Face_0cm_Ch60_Scan**DUT: 4N0432-01**

Communication System: WLAN_5G; Frequency: 5300 MHz; Duty Cycle: 1:1

Medium: B5G_141203 Medium parameters used: $f = 5300$ MHz; $\sigma = 5.416$ S/m; $\epsilon_r = 47.311$; $\rho = 1000$ kg/m³**Ambient Temperature : 23.1 °C; Liquid Temperature : 22.8 °C**

DASY5 Configuration:

- Probe: EX3DV4 - SN3976; ConvF(4.39, 4.39, 4.39); Calibrated: 2014/2/17;
- Sensor-Surface: 2mm (Mechanical Surface Detection)
- Electronics: DAE4 Sn1424; Calibrated: 2014/2/11
- Phantom: ELI v5.0; Type: QDOVA002AA; Serial: TP:1238
- Measurement SW: DASY52, Version 52.8 (8); SEMCAD X Version 14.6.10 (7331)

Ch60/Area Scan (141x181x1): Interpolated grid: dx=1.000 mm, dy=1.000 mm

Maximum value of SAR (interpolated) = 0.212 W/kg

Ch60/Zoom Scan (6x6x12)/Cube 0: Measurement grid: dx=5mm, dy=5mm, dz=2mm

Reference Value = 4.484 V/m; Power Drift = 0.17 dB

Peak SAR (extrapolated) = 0.257 W/kg

SAR(1 g) = 0.070 W/kg; SAR(10 g) = 0.027 W/kg

Maximum value of SAR (measured) = 0.136 W/kg

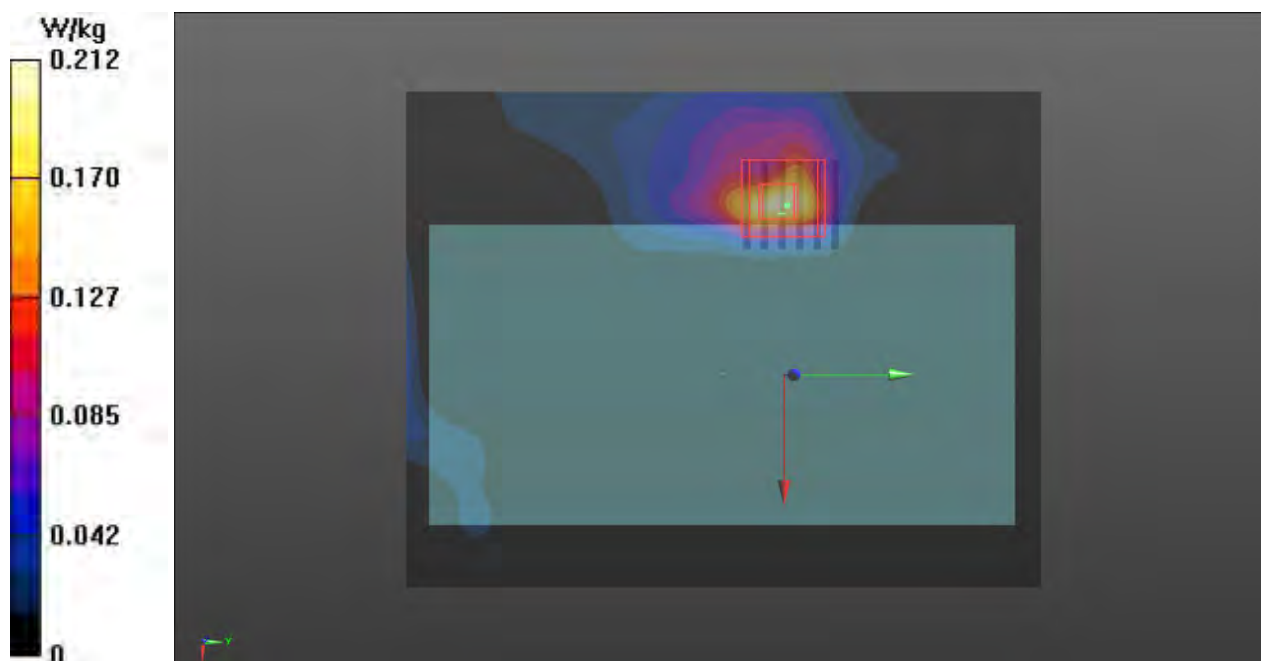

P19 802.11a_Rear Face_0cm_Ch60_Scan

DUT: 4N0432-01

Communication System: WLAN_5G; Frequency: 5300 MHz; Duty Cycle: 1:1

Medium: B5G_141203 Medium parameters used: $f = 5300$ MHz; $\sigma = 5.416$ S/m; $\epsilon_r = 47.311$; $\rho = 1000$ kg/m³

Ambient Temperature : 23.1 °C; Liquid Temperature : 22.8 °C

DASY5 Configuration:

- Probe: EX3DV4 - SN3976; ConvF(4.39, 4.39, 4.39); Calibrated: 2014/2/17;
- Sensor-Surface: 2mm (Mechanical Surface Detection)
- Electronics: DAE4 Sn1424; Calibrated: 2014/2/11
- Phantom: ELI v5.0; Type: QDOVA002AA; Serial: TP:1238
- Measurement SW: DASY52, Version 52.8 (8); SEMCAD X Version 14.6.10 (7331)

Ch60/Area Scan (121x181x1): Interpolated grid: dx=1.000 mm, dy=1.000 mm

Maximum value of SAR (interpolated) = 0.872 W/kg

Ch60/Zoom Scan (6x6x12)/Cube 0: Measurement grid: dx=5mm, dy=5mm, dz=2mm

Reference Value = 13.00 V/m; Power Drift = -0.05 dB

Peak SAR (extrapolated) = 2.18 W/kg

SAR(1 g) = 0.472 W/kg; SAR(10 g) = 0.161 W/kg

Maximum value of SAR (measured) = 1.03 W/kg

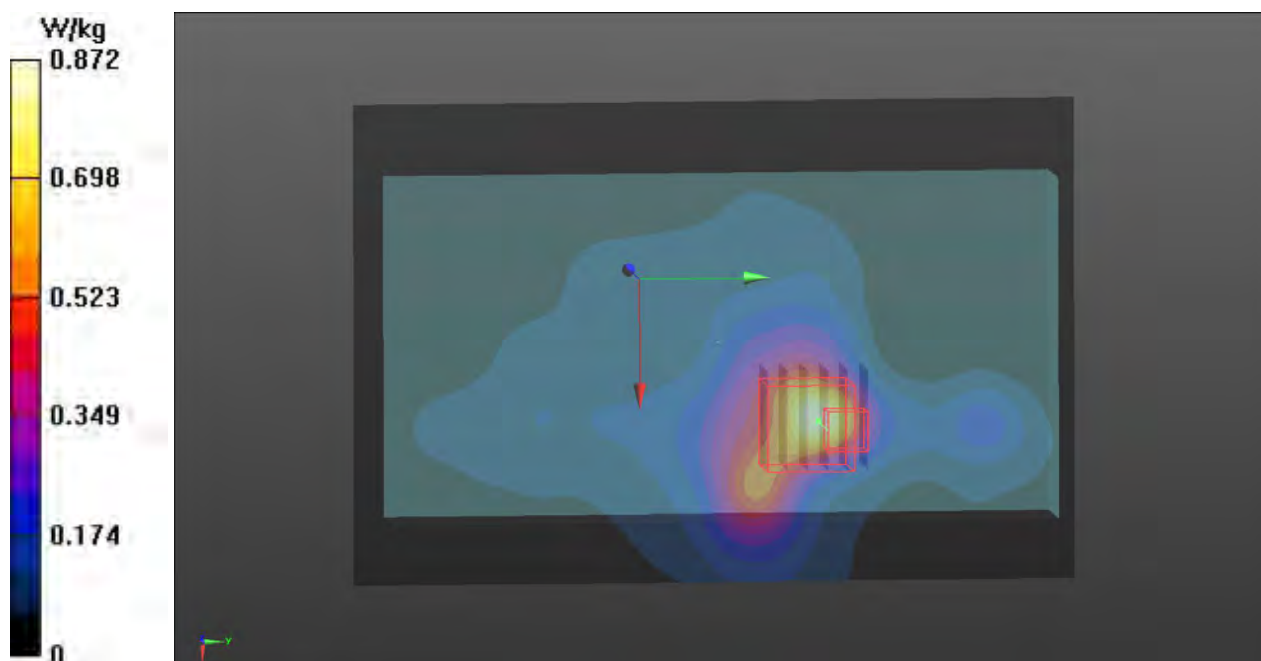

P20 802.11a_Left Side_0cm_Ch60_Scan

DUT: 4N0432-01

Communication System: WLAN_5G; Frequency: 5300 MHz; Duty Cycle: 1:1

Medium: B5G_141203 Medium parameters used: $f = 5300$ MHz; $\sigma = 5.416$ S/m; $\epsilon_r = 47.311$; $\rho = 1000$ kg/m³

Ambient Temperature : 23.1 °C; Liquid Temperature : 22.8 °C

DASY5 Configuration:

- Probe: EX3DV4 - SN3976; ConvF(4.39, 4.39, 4.39); Calibrated: 2014/2/17;
- Sensor-Surface: 2mm (Mechanical Surface Detection)
- Electronics: DAE4 Sn1424; Calibrated: 2014/2/11
- Phantom: ELI v5.0; Type: QDOVA002AA; Serial: TP:1238
- Measurement SW: DASY52, Version 52.8 (8); SEMCAD X Version 14.6.10 (7331)

Ch60/Area Scan (61x181x1): Interpolated grid: dx=1.000 mm, dy=1.000 mm

Maximum value of SAR (interpolated) = 1.74 W/kg

Ch60/Zoom Scan (6x6x12)/Cube 0: Measurement grid: dx=5mm, dy=5mm, dz=2mm

Reference Value = 19.07 V/m; Power Drift = -0.14 dB

Peak SAR (extrapolated) = 4.46 W/kg

SAR(1 g) = 0.980 W/kg; SAR(10 g) = 0.274 W/kg

Maximum value of SAR (measured) = 1.93 W/kg

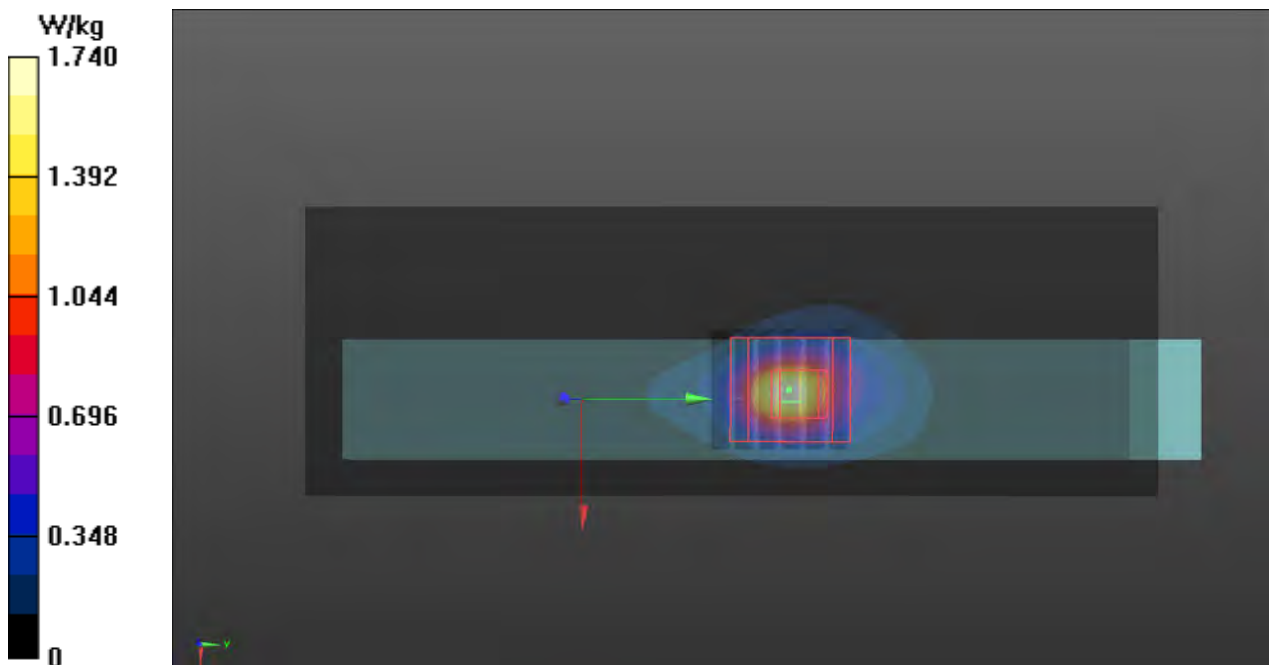

1g/10g Averaged SAR

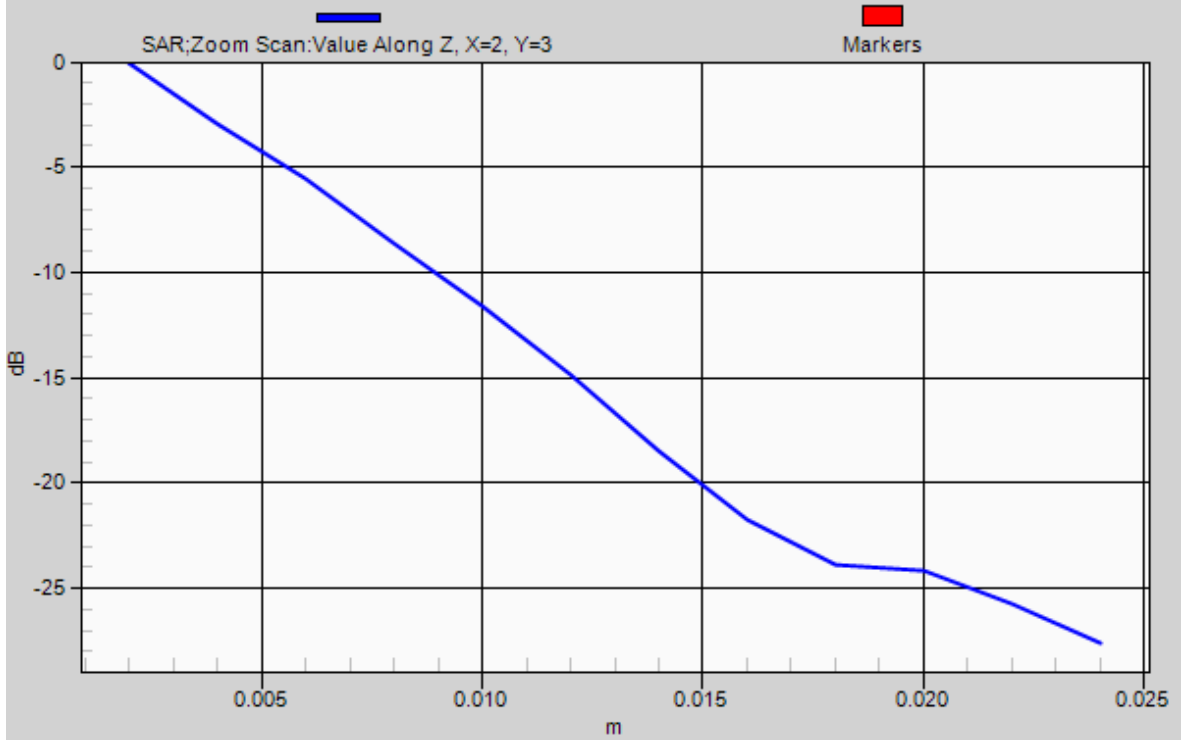

P21 802.11a_Left Side_0cm_Ch60_MSR

DUT: 4N0432-01

Communication System: WLAN_5G; Frequency: 5300 MHz; Duty Cycle: 1:1

Medium: B5G_141203 Medium parameters used: $f = 5300$ MHz; $\sigma = 5.416$ S/m; $\epsilon_r = 47.311$; $\rho = 1000$ kg/m³

Ambient Temperature : 23.1 °C; Liquid Temperature : 22.8 °C

DASY5 Configuration:

- Probe: EX3DV4 - SN3976; ConvF(4.39, 4.39, 4.39); Calibrated: 2014/2/17;
- Sensor-Surface: 2mm (Mechanical Surface Detection)
- Electronics: DAE4 Sn1424; Calibrated: 2014/2/11
- Phantom: ELI v5.0; Type: QDOVA002AA; Serial: TP:1238
- Measurement SW: DASY52, Version 52.8 (8); SEMCAD X Version 14.6.10 (7331)

Ch60/Area Scan (61x181x1): Interpolated grid: dx=1.000 mm, dy=1.000 mm

Maximum value of SAR (interpolated) = 1.10 W/kg

Ch60/Zoom Scan (6x6x12)/Cube 0: Measurement grid: dx=5mm, dy=5mm, dz=2mm

Reference Value = 14.38 V/m; Power Drift = -0.10 dB

Peak SAR (extrapolated) = 3.54 W/kg

SAR(1 g) = 0.761 W/kg; SAR(10 g) = 0.199 W/kg

Maximum value of SAR (measured) = 1.41 W/kg

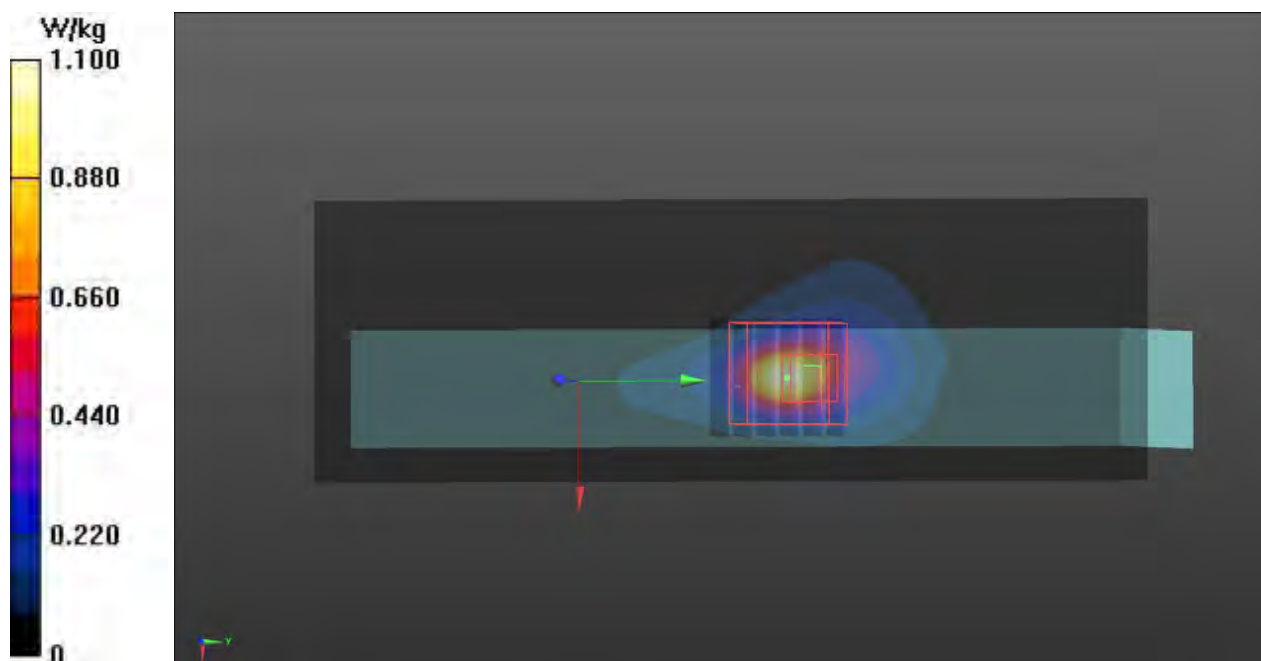

P53 802.11a_Left Side_1cm_Ch60_Scan

DUT: 4N0432-01

Communication System: WLAN_5G; Frequency: 5300 MHz; Duty Cycle: 1:1

Medium: B5G_141208 Medium parameters used: $f = 5300$ MHz; $\sigma = 5.424$ S/m; $\epsilon_r = 47.459$; $\rho = 1000$ kg/m³

Ambient Temperature : 23.2 °C; Liquid Temperature : 22.9 °C

DASY5 Configuration:

- Probe: EX3DV4 - SN3976; ConvF(4.39, 4.39, 4.39); Calibrated: 2014/2/17;
- Sensor-Surface: 2mm (Mechanical Surface Detection)
- Electronics: DAE4 Sn1424; Calibrated: 2014/2/11
- Phantom: ELI v5.0; Type: QDOVA002AA; Serial: TP:1238
- Measurement SW: DASY52, Version 52.8 (8); SEMCAD X Version 14.6.10 (7331)

Ch60/Area Scan (61x181x1): Interpolated grid: dx=1.000 mm, dy=1.000 mm

Maximum value of SAR (interpolated) = 0.333 W/kg

Ch60/Zoom Scan (6x6x12)/Cube 0: Measurement grid: dx=5mm, dy=5mm, dz=2mm

Reference Value = 7.831 V/m; Power Drift = 0.05 dB

Peak SAR (extrapolated) = 0.840 W/kg

SAR(1 g) = 0.219 W/kg; SAR(10 g) = 0.084 W/kg

Maximum value of SAR (measured) = 0.392 W/kg

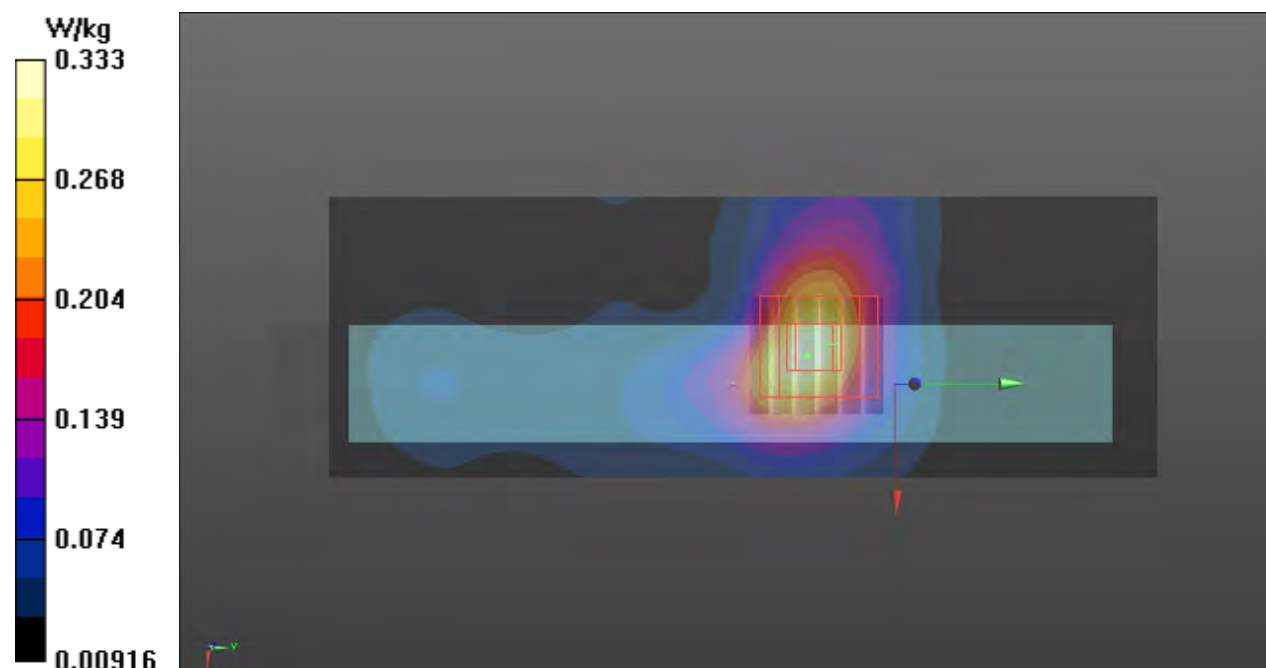

P26 802.11a_Front Face_0cm_Ch100_Scan

DUT: 4N0432-01

Communication System: WLAN_5G; Frequency: 5500 MHz; Duty Cycle: 1:1

Medium: B5G_141203 Medium parameters used: $f = 5500$ MHz; $\sigma = 5.676$ S/m; $\epsilon_r = 46.988$; $\rho = 1000$ kg/m³

Ambient Temperature : 23.1 °C; Liquid Temperature : 22.8 °C

DASY5 Configuration:

- Probe: EX3DV4 - SN3976; ConvF(4.17, 4.17, 4.17); Calibrated: 2014/2/17;
- Sensor-Surface: 2mm (Mechanical Surface Detection)
- Electronics: DAE4 Sn1424; Calibrated: 2014/2/11
- Phantom: ELI v5.0; Type: QDOVA002AA; Serial: TP:1238
- Measurement SW: DASY52, Version 52.8 (8); SEMCAD X Version 14.6.10 (7331)

Ch100/Area Scan (141x181x1): Interpolated grid: dx=1.000 mm, dy=1.000 mm

Maximum value of SAR (interpolated) = 0.274 W/kg

Ch100/Zoom Scan (6x6x12)/Cube 0: Measurement grid: dx=5mm, dy=5mm, dz=2mm

Reference Value = 4.670 V/m; Power Drift = -0.09 dB

Peak SAR (extrapolated) = 0.527 W/kg

SAR(1 g) = 0.092 W/kg; SAR(10 g) = 0.034 W/kg

Maximum value of SAR (measured) = 0.163 W/kg

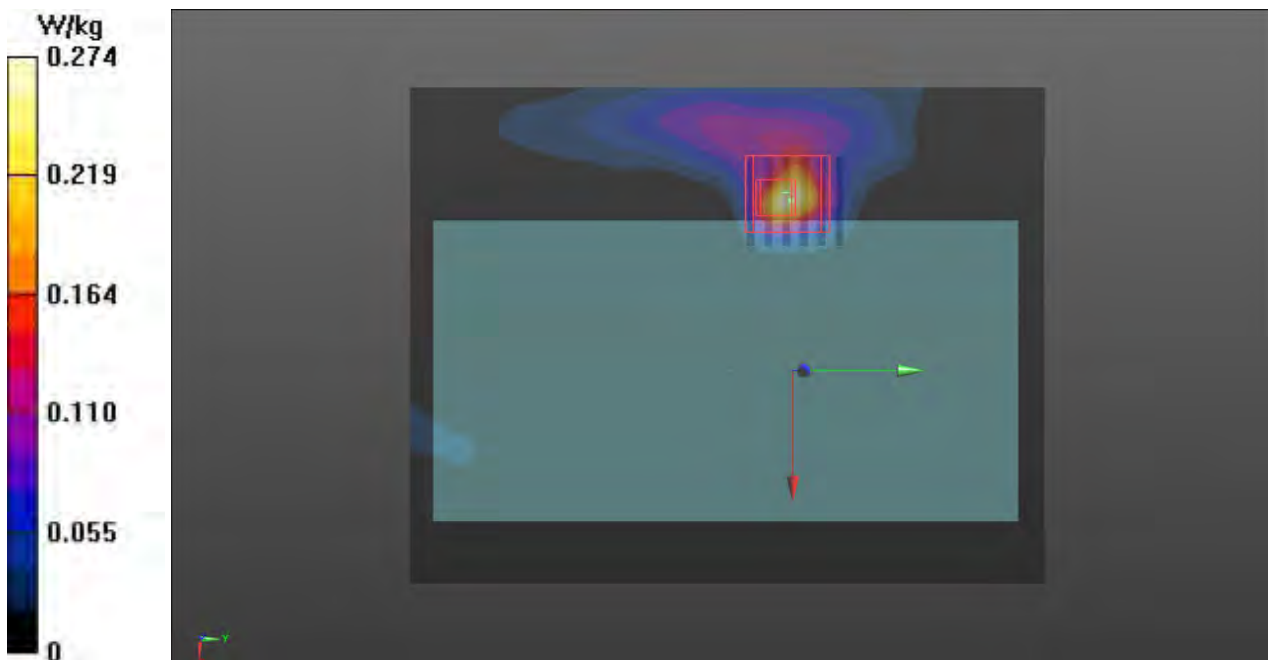

P27 802.11a_Rear Face_0cm_Ch100_Scan**DUT: 4N0432-01**

Communication System: WLAN_5G; Frequency: 5500 MHz; Duty Cycle: 1:1

Medium: B5G_141203 Medium parameters used: $f = 5500$ MHz; $\sigma = 5.676$ S/m; $\epsilon_r = 46.988$; $\rho = 1000$ kg/m³**Ambient Temperature : 23.1 °C; Liquid Temperature : 22.8 °C**

DASY5 Configuration:

- Probe: EX3DV4 - SN3976; ConvF(4.17, 4.17, 4.17); Calibrated: 2014/2/17;
- Sensor-Surface: 2mm (Mechanical Surface Detection)
- Electronics: DAE4 Sn1424; Calibrated: 2014/2/11
- Phantom: ELI v5.0; Type: QDOVA002AA; Serial: TP:1238
- Measurement SW: DASY52, Version 52.8 (8); SEMCAD X Version 14.6.10 (7331)

Ch100/Area Scan (121x181x1): Interpolated grid: dx=1.000 mm, dy=1.000 mm

Maximum value of SAR (interpolated) = 0.534 W/kg

Ch100/Zoom Scan (6x6x12)/Cube 0: Measurement grid: dx=5mm, dy=5mm, dz=2mm

Reference Value = 9.634 V/m; Power Drift = -0.02 dB

Peak SAR (extrapolated) = 1.26 W/kg

SAR(1 g) = 0.313 W/kg; SAR(10 g) = 0.115 W/kg

Maximum value of SAR (measured) = 0.595 W/kg

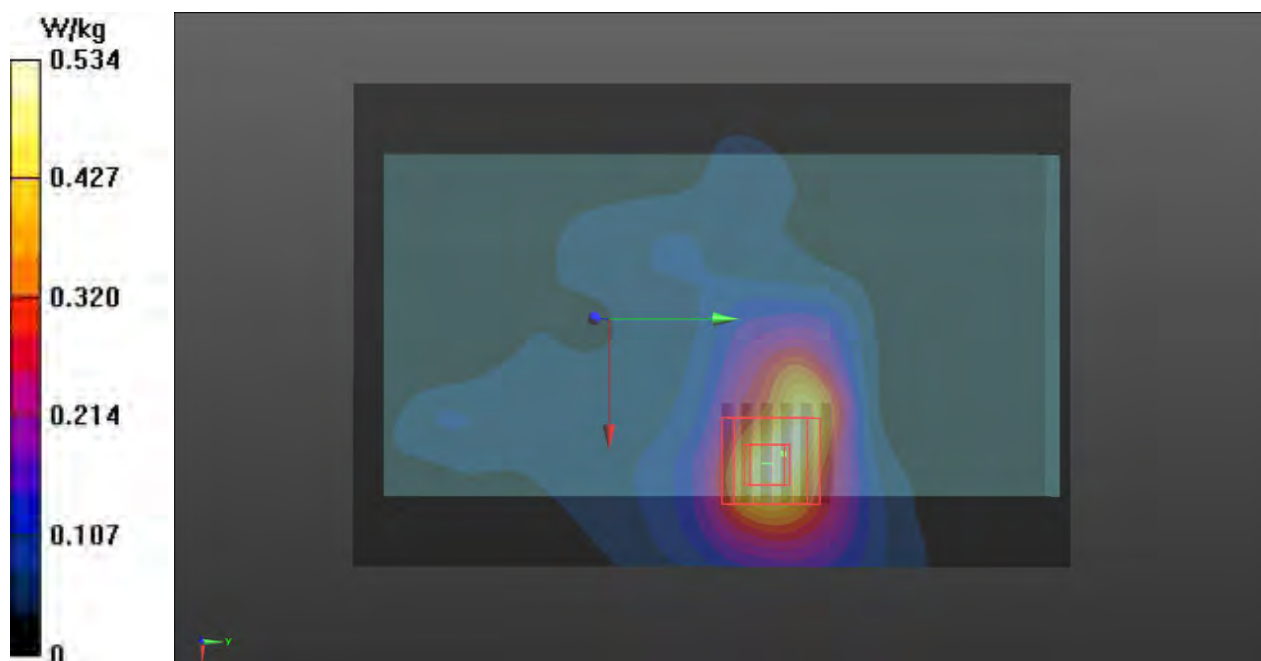

P28 802.11a_Left Side_0cm_Ch100_Scan

DUT: 4N0432-01

Communication System: WLAN_5G; Frequency: 5500 MHz; Duty Cycle: 1:1

Medium: B5G_141203 Medium parameters used: $f = 5500$ MHz; $\sigma = 5.676$ S/m; $\epsilon_r = 46.988$; $\rho = 1000$ kg/m³

Ambient Temperature : 23.1 °C; Liquid Temperature : 22.8 °C

DASY5 Configuration:

- Probe: EX3DV4 - SN3976; ConvF(4.17, 4.17, 4.17); Calibrated: 2014/2/17;
- Sensor-Surface: 2mm (Mechanical Surface Detection)
- Electronics: DAE4 Sn1424; Calibrated: 2014/2/11
- Phantom: ELI v5.0; Type: QDOVA002AA; Serial: TP:1238
- Measurement SW: DASY52, Version 52.8 (8); SEMCAD X Version 14.6.10 (7331)

Ch100/Area Scan (61x181x1): Interpolated grid: dx=1.000 mm, dy=1.000 mm

Maximum value of SAR (interpolated) = 1.04 W/kg

Ch100/Zoom Scan (6x6x12)/Cube 0: Measurement grid: dx=5mm, dy=5mm, dz=2mm

Reference Value = 12.60 V/m; Power Drift = 0.06 dB

Peak SAR (extrapolated) = 3.82 W/kg

SAR(1 g) = 0.796 W/kg; SAR(10 g) = 0.222 W/kg

Maximum value of SAR (measured) = 1.67 W/kg

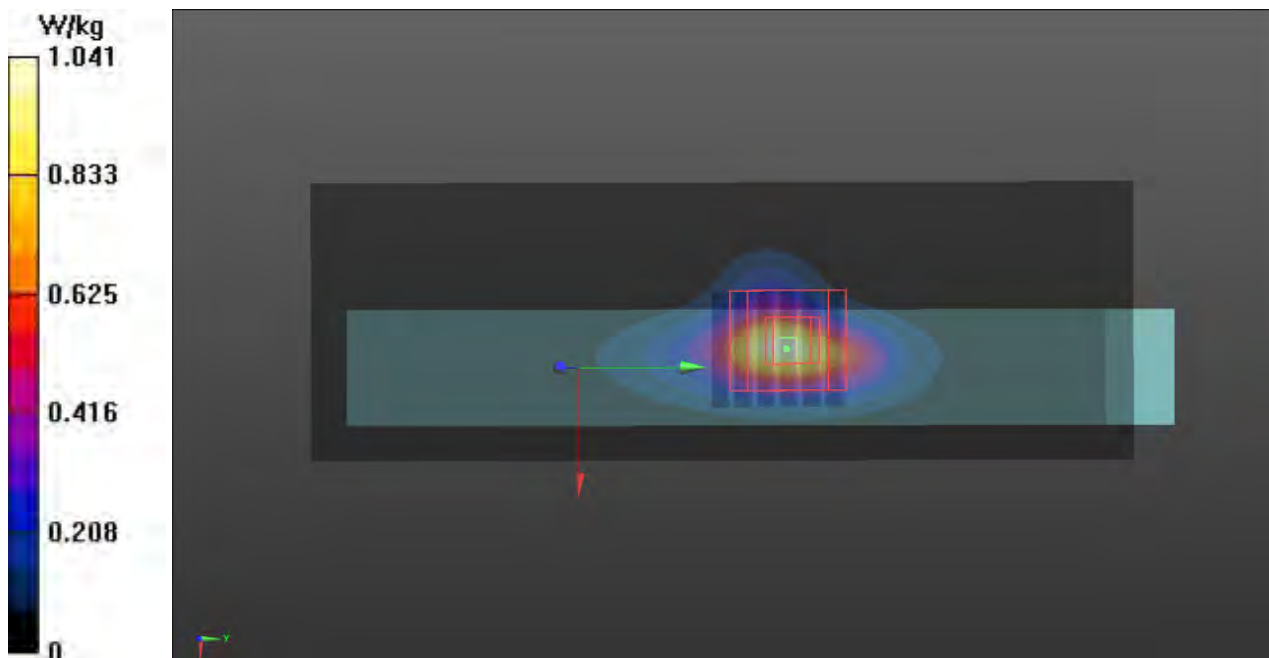

P29 802.11a_Left Side_0cm_Ch100_MSR**DUT: 4N0432-01**

Communication System: WLAN_5G; Frequency: 5500 MHz; Duty Cycle: 1:1

Medium: B5G_141203 Medium parameters used: $f = 5500$ MHz; $\sigma = 5.676$ S/m; $\epsilon_r = 46.988$; $\rho = 1000$ kg/m³**Ambient Temperature : 23.1 °C; Liquid Temperature : 22.8 °C**

DASY5 Configuration:

- Probe: EX3DV4 - SN3976; ConvF(4.17, 4.17, 4.17); Calibrated: 2014/2/17;
- Sensor-Surface: 2mm (Mechanical Surface Detection)
- Electronics: DAE4 Sn1424; Calibrated: 2014/2/11
- Phantom: ELI v5.0; Type: QDOVA002AA; Serial: TP:1238
- Measurement SW: DASY52, Version 52.8 (8); SEMCAD X Version 14.6.10 (7331)

Ch100/Area Scan (61x181x1): Interpolated grid: dx=1.000 mm, dy=1.000 mm

Maximum value of SAR (interpolated) = 1.15 W/kg

Ch100/Zoom Scan (6x6x12)/Cube 0: Measurement grid: dx=5mm, dy=5mm, dz=2mm

Reference Value = 13.38 V/m; Power Drift = 0.01 dB

Peak SAR (extrapolated) = 3.97 W/kg

SAR(1 g) = 0.828 W/kg; SAR(10 g) = 0.231 W/kg

Maximum value of SAR (measured) = 1.71 W/kg

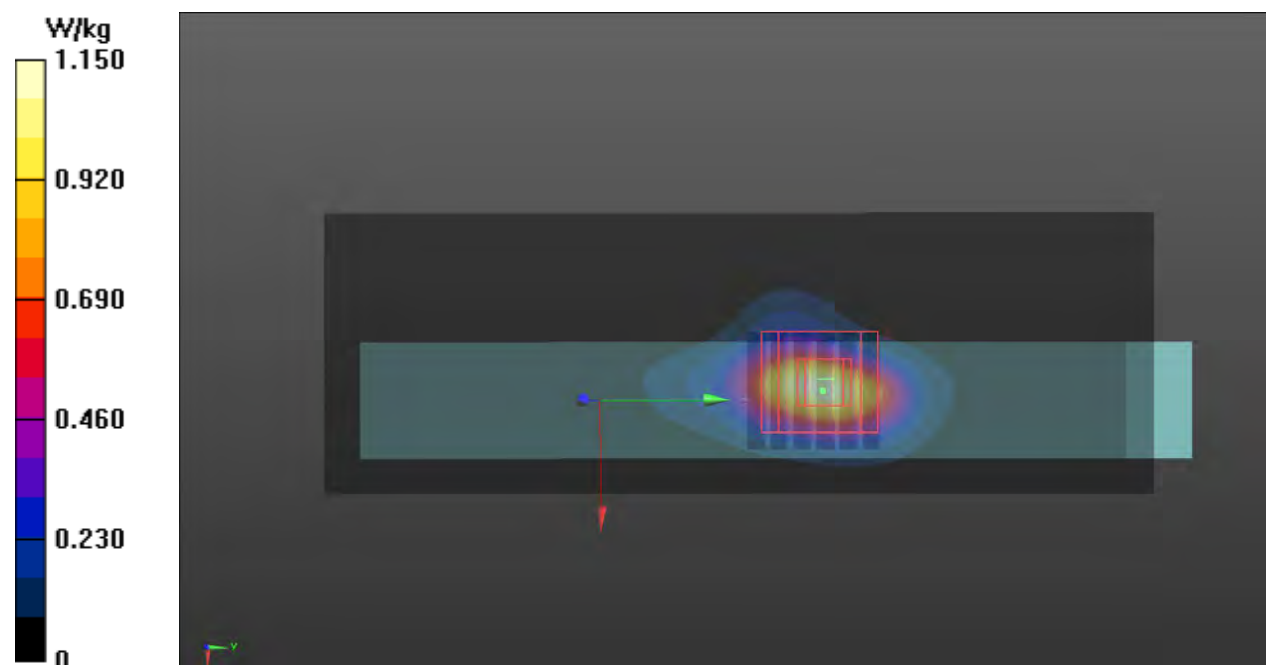

P54 802.11a_Left Side_1cm_Ch100_MSR

DUT: 4N0432-01

Communication System: WLAN_5G; Frequency: 5500 MHz; Duty Cycle: 1:1

Medium: B5G_141208 Medium parameters used: $f = 5500$ MHz; $\sigma = 5.685$ S/m; $\epsilon_r = 47.135$; $\rho = 1000$ kg/m³

Ambient Temperature : 23.2 °C; Liquid Temperature : 22.9 °C

DASY5 Configuration:

- Probe: EX3DV4 - SN3976; ConvF(4.17, 4.17, 4.17); Calibrated: 2014/2/17;
- Sensor-Surface: 2mm (Mechanical Surface Detection)
- Electronics: DAE4 Sn1424; Calibrated: 2014/2/11
- Phantom: ELI v5.0; Type: QDOVA002AA; Serial: TP:1238
- Measurement SW: DASY52, Version 52.8 (8); SEMCAD X Version 14.6.10 (7331)

Ch100/Area Scan (61x181x1): Interpolated grid: dx=1.000 mm, dy=1.000 mm

Maximum value of SAR (interpolated) = 0.417 W/kg

Ch100/Zoom Scan (6x6x12)/Cube 0: Measurement grid: dx=5mm, dy=5mm, dz=2mm

Reference Value = 9.034 V/m; Power Drift = -0.03 dB

Peak SAR (extrapolated) = 0.983 W/kg

SAR(1 g) = 0.252 W/kg; SAR(10 g) = 0.095 W/kg

Maximum value of SAR (measured) = 0.458 W/kg

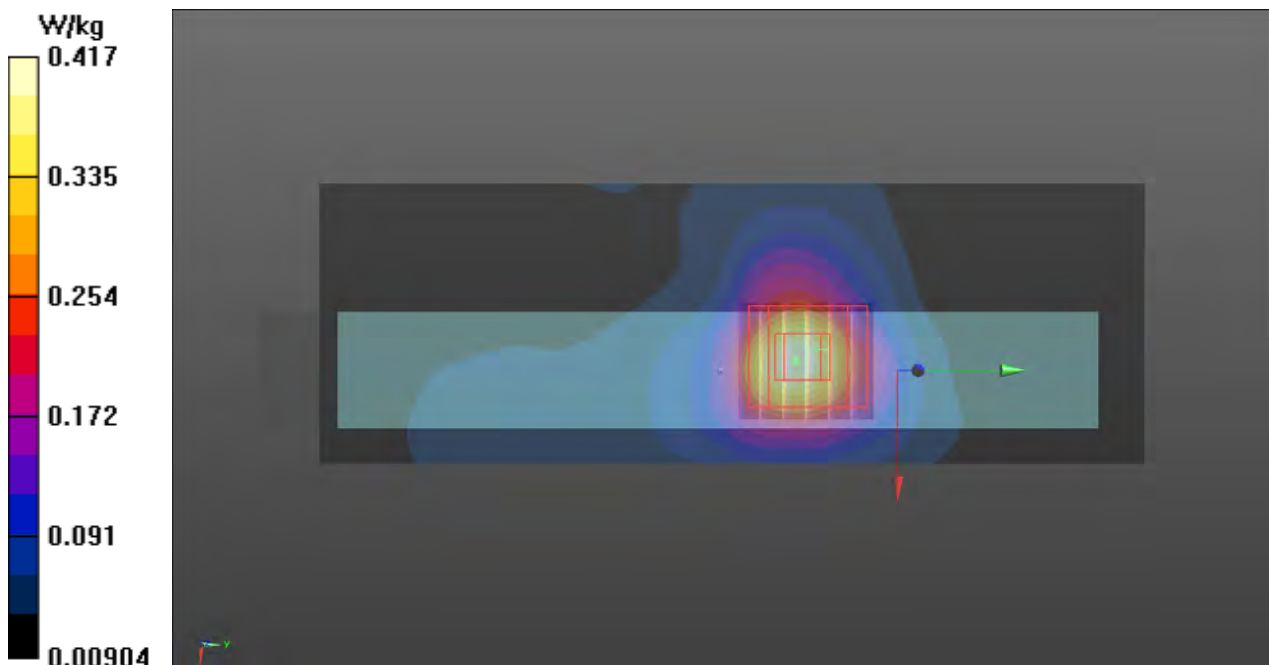

1g/10g Averaged SAR

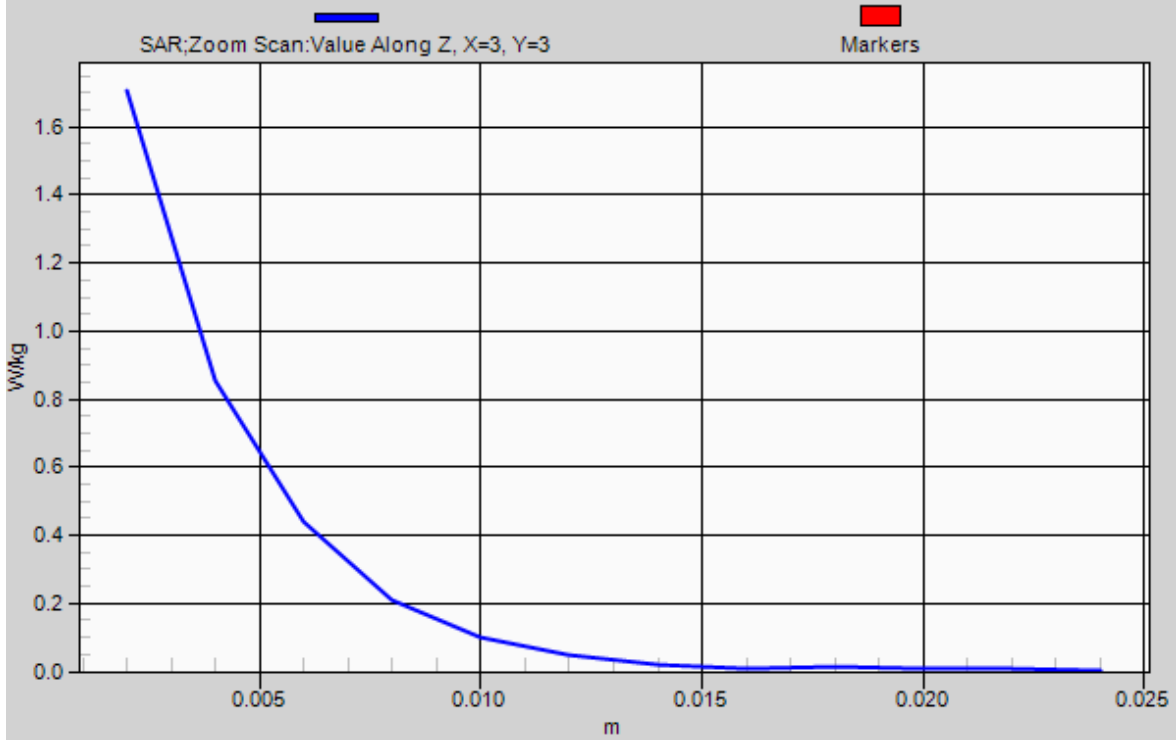

P38 802.11a_Front Face_0cm_Ch157_Scan**DUT: 4N0432-01**

Communication System: WLAN_5G; Frequency: 5785 MHz; Duty Cycle: 1:1

Medium: B5G_141203 Medium parameters used: $f = 5785$ MHz; $\sigma = 6.07$ S/m; $\epsilon_r = 46.526$; $\rho = 1000$ kg/m³**Ambient Temperature : 23.1 °C; Liquid Temperature : 22.8 °C**

DASY5 Configuration:

- Probe: EX3DV4 - SN3976; ConvF(4.26, 4.26, 4.26); Calibrated: 2014/2/17;
- Sensor-Surface: 2mm (Mechanical Surface Detection)
- Electronics: DAE4 Sn1424; Calibrated: 2014/2/11
- Phantom: ELI v5.0; Type: QDOVA002AA; Serial: TP:1238
- Measurement SW: DASY52, Version 52.8 (8); SEMCAD X Version 14.6.10 (7331)

Ch157/Area Scan (141x181x1): Interpolated grid: dx=1.000 mm, dy=1.000 mm

Maximum value of SAR (interpolated) = 0.163 W/kg

Ch157/Zoom Scan (6x6x12)/Cube 0: Measurement grid: dx=5mm, dy=5mm, dz=2mm

Reference Value = 3.879 V/m; Power Drift = -0.09 dB

Peak SAR (extrapolated) = 0.202 W/kg

SAR(1 g) = 0.054 W/kg; SAR(10 g) = 0.021 W/kg

Maximum value of SAR (measured) = 0.105 W/kg

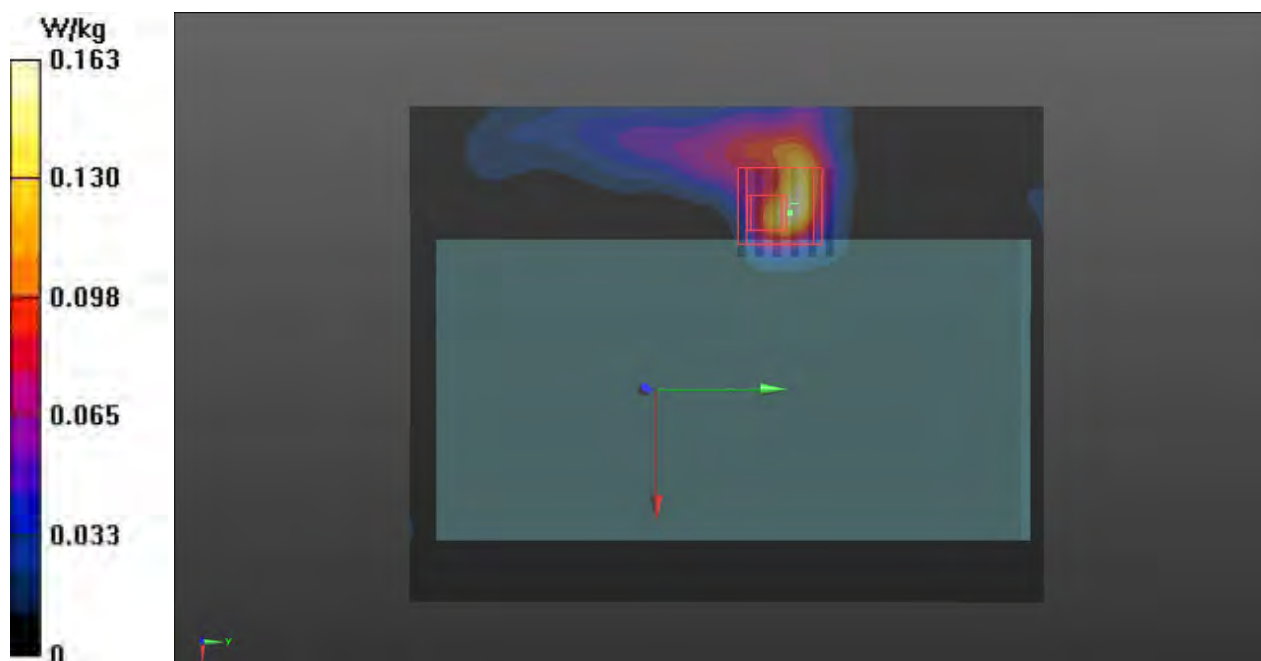

P39 802.11a_Rear Face_0cm_Ch157_Scan**DUT: 4N0432-01**

Communication System: WLAN_5G; Frequency: 5785 MHz; Duty Cycle: 1:1

Medium: B5G_141203 Medium parameters used: $f = 5785$ MHz; $\sigma = 6.07$ S/m; $\epsilon_r = 46.526$; $\rho = 1000$ kg/m³**Ambient Temperature : 23.1 °C; Liquid Temperature : 22.8 °C**

DASY5 Configuration:

- Probe: EX3DV4 - SN3976; ConvF(4.26, 4.26, 4.26); Calibrated: 2014/2/17;
- Sensor-Surface: 2mm (Mechanical Surface Detection)
- Electronics: DAE4 Sn1424; Calibrated: 2014/2/11
- Phantom: ELI v5.0; Type: QDOVA002AA; Serial: TP:1238
- Measurement SW: DASY52, Version 52.8 (8); SEMCAD X Version 14.6.10 (7331)

Ch157/Area Scan (121x181x1): Interpolated grid: dx=1.000 mm, dy=1.000 mm

Maximum value of SAR (interpolated) = 0.409 W/kg

Ch157/Zoom Scan (6x6x12)/Cube 0: Measurement grid: dx=5mm, dy=5mm, dz=2mm

Reference Value = 8.413 V/m; Power Drift = -0.01 dB

Peak SAR (extrapolated) = 1.22 W/kg

SAR(1 g) = 0.290 W/kg; SAR(10 g) = 0.099 W/kg

Maximum value of SAR (measured) = 0.568 W/kg

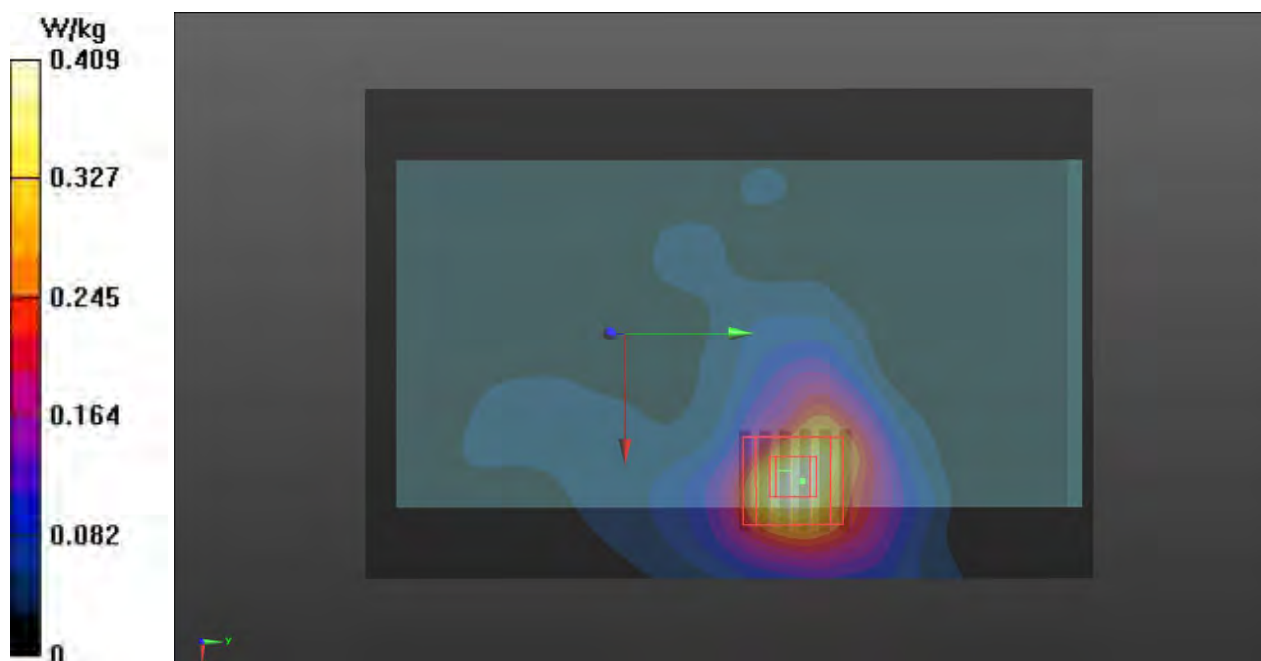

P40 802.11a_Left Side_0cm_Ch157_Scan**DUT: 4N0432-01**

Communication System: WLAN_5G; Frequency: 5785 MHz; Duty Cycle: 1:1

Medium: B5G_141203 Medium parameters used: $f = 5785$ MHz; $\sigma = 6.07$ S/m; $\epsilon_r = 46.526$; $\rho = 1000$ kg/m³**Ambient Temperature : 23.1 °C; Liquid Temperature : 22.8 °C**

DASY5 Configuration:

- Probe: EX3DV4 - SN3976; ConvF(4.26, 4.26, 4.26); Calibrated: 2014/2/17;
- Sensor-Surface: 2mm (Mechanical Surface Detection)
- Electronics: DAE4 Sn1424; Calibrated: 2014/2/11
- Phantom: ELI v5.0; Type: QDOVA002AA; Serial: TP:1238
- Measurement SW: DASY52, Version 52.8 (8); SEMCAD X Version 14.6.10 (7331)

Ch157/Area Scan (61x181x1): Interpolated grid: dx=1.000 mm, dy=1.000 mm

Maximum value of SAR (interpolated) = 1.07 W/kg

Ch157/Zoom Scan (6x6x12)/Cube 0: Measurement grid: dx=5mm, dy=5mm, dz=2mm

Reference Value = 12.93 V/m; Power Drift = 0.04 dB

Peak SAR (extrapolated) = 3.17 W/kg

SAR(1 g) = 0.649 W/kg; SAR(10 g) = 0.180 W/kg

Maximum value of SAR (measured) = 1.30 W/kg

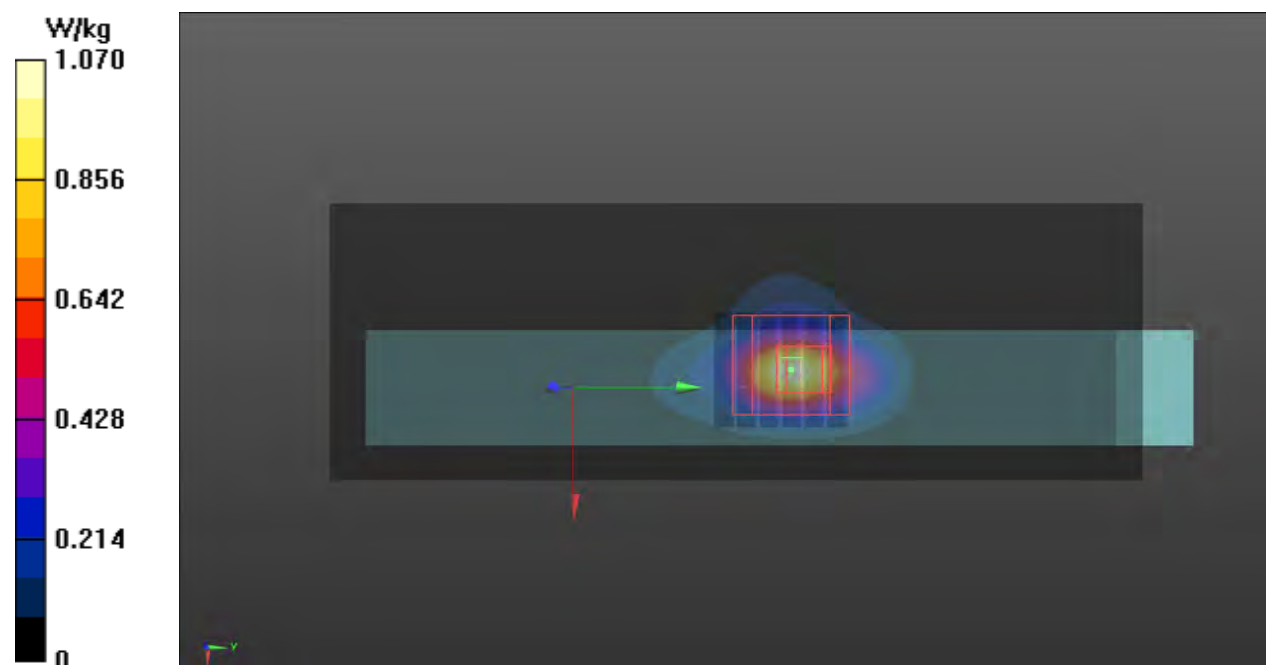

1g/10g Averaged SAR

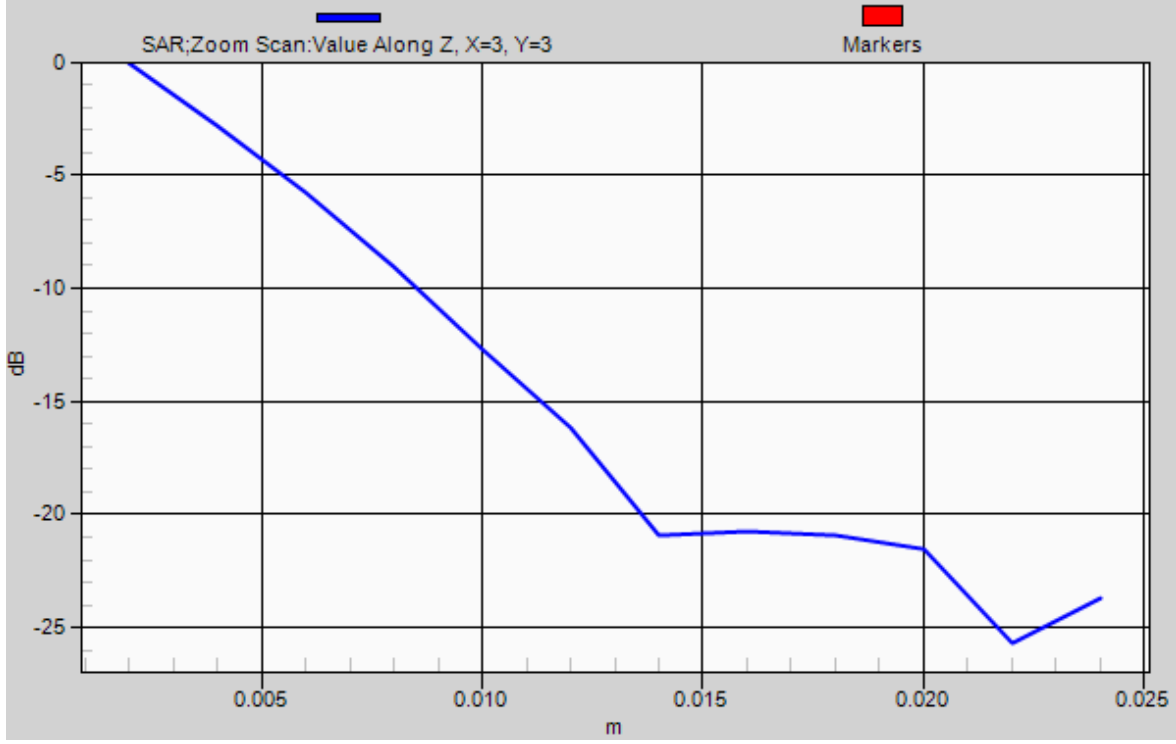

P41 802.11a_Left Side_0cm_Ch157_MSR**DUT: 4N0432-01**

Communication System: WLAN_5G; Frequency: 5785 MHz; Duty Cycle: 1:1

Medium: B5G_141203 Medium parameters used: $f = 5785$ MHz; $\sigma = 6.07$ S/m; $\epsilon_r = 46.526$; $\rho = 1000$ kg/m³**Ambient Temperature : 23.1 °C; Liquid Temperature : 22.8 °C**

DASY5 Configuration:

- Probe: EX3DV4 - SN3976; ConvF(4.26, 4.26, 4.26); Calibrated: 2014/2/17;
- Sensor-Surface: 2mm (Mechanical Surface Detection)
- Electronics: DAE4 Sn1424; Calibrated: 2014/2/11
- Phantom: ELI v5.0; Type: QDOVA002AA; Serial: TP:1238
- Measurement SW: DASY52, Version 52.8 (8); SEMCAD X Version 14.6.10 (7331)

Ch157/Area Scan (61x181x1): Interpolated grid: dx=1.000 mm, dy=1.000 mm

Maximum value of SAR (interpolated) = 1.03 W/kg

Ch157/Zoom Scan (6x6x12)/Cube 0: Measurement grid: dx=5mm, dy=5mm, dz=2mm

Reference Value = 12.30 V/m; Power Drift = 0.05 dB

Peak SAR (extrapolated) = 3.08 W/kg

SAR(1 g) = 0.629 W/kg; SAR(10 g) = 0.179 W/kg

Maximum value of SAR (measured) = 1.26 W/kg

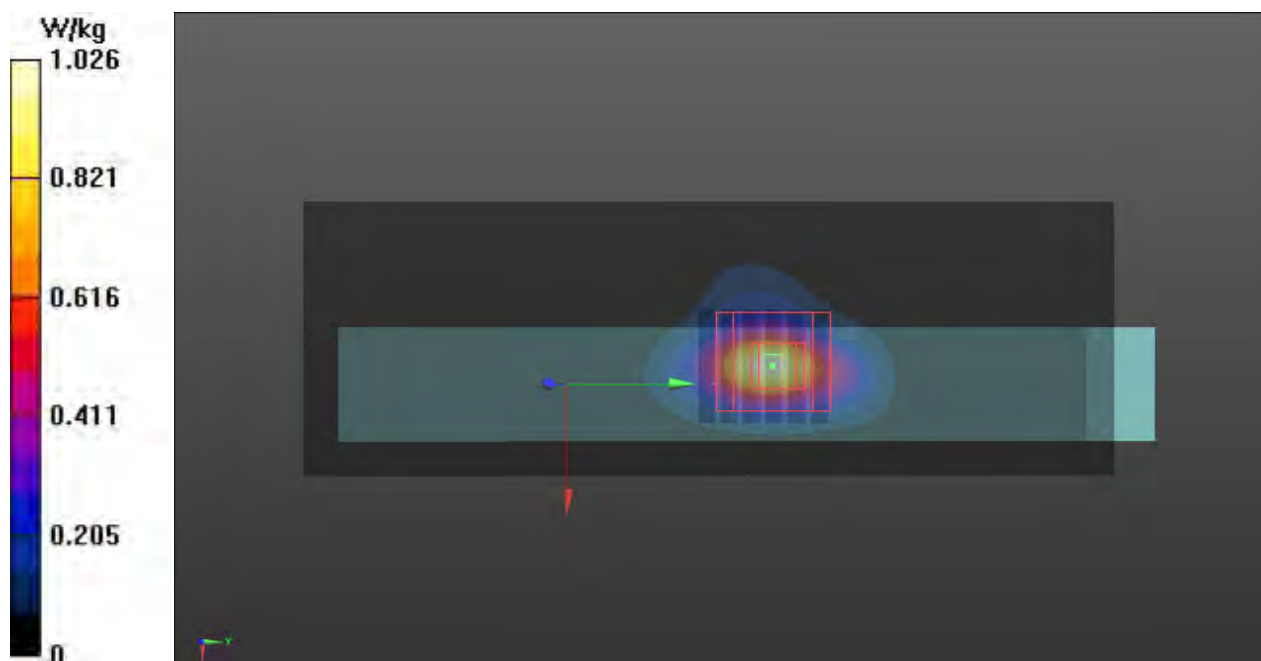

P55 802.11a_Left Side_1cm_Ch157_MSR

DUT: 4N0432-01

Communication System: WLAN_5G; Frequency: 5785 MHz; Duty Cycle: 1:1
Medium: B5G_141208 Medium parameters used: $f = 5785$ MHz; $\sigma = 6.08$ S/m; $\epsilon_r = 46.666$; $\rho = 1000$ kg/m³
Ambient Temperature : 23.2 °C; Liquid Temperature : 22.9 °C

DASY5 Configuration:

- Probe: EX3DV4 - SN3976; ConvF(4.26, 4.26, 4.26); Calibrated: 2014/2/17;
- Sensor-Surface: 2mm (Mechanical Surface Detection)
- Electronics: DAE4 Sn1424; Calibrated: 2014/2/11
- Phantom: ELI v5.0; Type: QDOVA002AA; Serial: TP:1238
- Measurement SW: DASY52, Version 52.8 (8); SEMCAD X Version 14.6.10 (7331)

Ch157/Area Scan (61x181x1): Interpolated grid: dx=1.000 mm, dy=1.000 mm
Maximum value of SAR (interpolated) = 0.358 W/kg

Ch157/Zoom Scan (6x6x12)/Cube 0: Measurement grid: dx=5mm, dy=5mm, dz=2mm
Reference Value = 7.873 V/m; Power Drift = -0.00 dB
Peak SAR (extrapolated) = 0.901 W/kg
SAR(1 g) = 0.214 W/kg; SAR(10 g) = 0.081 W/kg
Maximum value of SAR (measured) = 0.389 W/kg

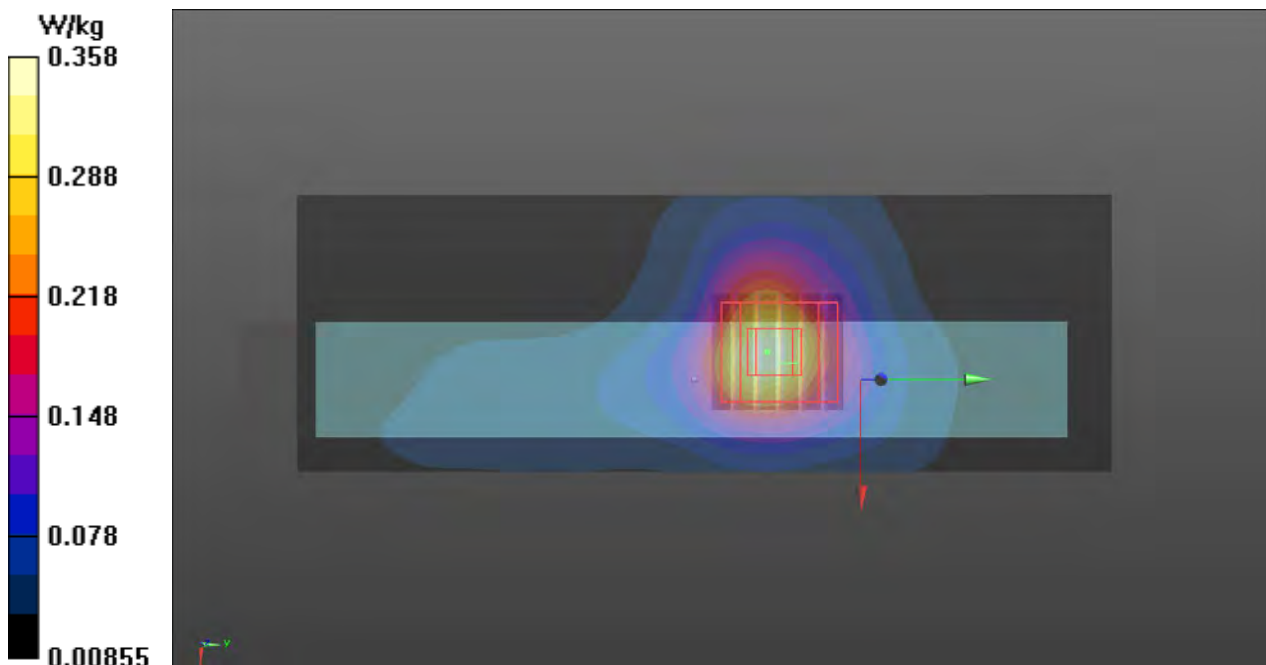

IMPORTANT NOTICE

USAGE OF THE DAE 4

The DAE unit is a delicate, high precision instrument and requires careful treatment by the user. There are no serviceable parts inside the DAE. Special attention shall be given to the following points:

Battery Exchange: The battery cover of the DAE4 unit is closed using a screw, over tightening the screw may cause the threads inside the DAE to wear out.

Shipping of the DAE: Before shipping the DAE to SPEAG for calibration, remove the batteries and pack the DAE in an antistatic bag. This antistatic bag shall then be packed into a larger box or container which protects the DAE from impacts during transportation. The package shall be marked to indicate that a fragile instrument is inside.

E-Stop Failures: Touch detection may be malfunctioning due to broken magnets in the E-stop. Rough handling of the E-stop may lead to damage of these magnets. Touch and collision errors are often caused by dust and dirt accumulated in the E-stop. To prevent E-stop failure, the customer shall always mount the probe to the DAE carefully and keep the DAE unit in a non-dusty environment if not used for measurements.

Repair: Minor repairs are performed at no extra cost during the annual calibration. However, SPEAG reserves the right to charge for any repair especially if rough unprofessional handling caused the defect.

DASY Configuration Files: Since the exact values of the DAE input resistances, as measured during the calibration procedure of a DAE unit, are not used by the DASY software, a nominal value of 200 MOhm is given in the corresponding configuration file.

Important Note:

Warranty and calibration is void if the DAE unit is disassembled partly or fully by the Customer.

Important Note:

Never attempt to grease or oil the E-stop assembly. Cleaning and readjusting of the E-stop assembly is allowed by certified SPEAG personnel only and is part of the annual calibration procedure.

Important Note:

To prevent damage of the DAE probe connector pins, use great care when installing the probe to the DAE. Carefully connect the probe with the connector notch oriented in the mating position. Avoid any rotational movement of the probe body versus the DAE while turning the locking nut of the connector. The same care shall be used when disconnecting the probe from the DAE.



Accredited by the Swiss Accreditation Service (SAS)
The Swiss Accreditation Service is one of the signatories to the EA
Multilateral Agreement for the recognition of calibration certificates

Accreditation No.: **SCS 108**

Client **Sporton TW (Auden)**

Certificate No: **DAE4-1424_Feb14**

CALIBRATION CERTIFICATE

Object: **DAE4 - SD 000 D04 BM - SN: 1424**

Calibration procedure(s): **QA CAL-06.v26
Calibration procedure for the data acquisition electronics (DAE)**

Calibration date: **February 11, 2014**

This calibration certificate documents the traceability to national standards, which realize the physical units of measurements (SI).
The measurements and the uncertainties with confidence probability are given on the following pages and are part of the certificate.

All calibrations have been conducted in the closed laboratory facility: environment temperature (22 ± 3)°C and humidity < 70%.

Calibration Equipment used (M&TE critical for calibration)

Primary Standards	ID #	Cal Date (Certificate No.)	Scheduled Calibration
Keithley Multimeter Type 2001	SN: 0810278	01-Oct-13 (No:13976)	Oct-14
Secondary Standards	ID #	Check Date (in house)	Scheduled Check
Auto DAE Calibration Unit	SE UWS 053 AA 1001	07-Jan-14 (in house check)	In house check: Jan-15
Calibrator Box V2.1	SE UMS 006 AA 1002	07-Jan-14 (in house check)	In house check: Jan-15

Calibrated by:	Name R. Mayoraz	Function Technician	Signature <i>R. Mayoraz</i>
Approved by:	Name Fin Bomholt	Function Deputy Technical Manager	Signature <i>F. Bomholt</i>

Issued: February 11, 2014

This calibration certificate shall not be reproduced except in full without written approval of the laboratory.



Accredited by the Swiss Accreditation Service (SAS)

The Swiss Accreditation Service is one of the signatories to the EA
Multilateral Agreement for the recognition of calibration certificates

Accreditation No.: **SCS 108**

Glossary

DAE	data acquisition electronics
Connector angle	information used in DASY system to align probe sensor X to the robot coordinate system.

Methods Applied and Interpretation of Parameters

- *DC Voltage Measurement:* Calibration Factor assessed for use in DASY system by comparison with a calibrated instrument traceable to national standards. The figure given corresponds to the full scale range of the voltmeter in the respective range.
- *Connector angle:* The angle of the connector is assessed measuring the angle mechanically by a tool inserted. Uncertainty is not required.
- The following parameters as documented in the Appendix contain technical information as a result from the performance test and require no uncertainty.
 - *DC Voltage Measurement Linearity:* Verification of the Linearity at +10% and -10% of the nominal calibration voltage. Influence of offset voltage is included in this measurement.
 - *Common mode sensitivity:* Influence of a positive or negative common mode voltage on the differential measurement.
 - *Channel separation:* Influence of a voltage on the neighbor channels not subject to an input voltage.
 - *AD Converter Values with inputs shorted:* Values on the internal AD converter corresponding to zero input voltage
 - *Input Offset Measurement:* Output voltage and statistical results over a large number of zero voltage measurements.
 - *Input Offset Current:* Typical value for information; Maximum channel input offset current, not considering the input resistance.
 - *Input resistance:* Typical value for information: DAE input resistance at the connector, during internal auto-zeroing and during measurement.
 - *Low Battery Alarm Voltage:* Typical value for information. Below this voltage, a battery alarm signal is generated.
 - *Power consumption:* Typical value for information. Supply currents in various operating modes.

DC Voltage Measurement

A/D - Converter Resolution nominal

High Range: 1LSB = 6.1 μ V, full range = -100...+300 mV

Low Range: 1LSB = 61nV, full range = -1.....+3mV

DASY measurement parameters: Auto Zero Time: 3 sec; Measuring time: 3 sec

Calibration Factors	X	Y	Z
High Range	403.049 \pm 0.02% (k=2)	403.528 \pm 0.02% (k=2)	403.106 \pm 0.02% (k=2)
Low Range	3.96725 \pm 1.50% (k=2)	3.96894 \pm 1.50% (k=2)	3.98334 \pm 1.50% (k=2)

Connector Angle

Connector Angle to be used in DASY system	359.0 \pm 1 $^{\circ}$
---	--------------------------

Appendix

1. DC Voltage Linearity

High Range		Reading (μV)	Difference (μV)	Error (%)
Channel X	+ Input	200030.76	-3.28	-0.00
Channel X	+ Input	20005.77	1.83	0.01
Channel X	- Input	-20003.61	1.53	-0.01
Channel Y	+ Input	200031.93	-2.16	-0.00
Channel Y	+ Input	20003.24	-0.56	-0.00
Channel Y	- Input	-20004.71	0.63	-0.00
Channel Z	+ Input	200033.53	-0.36	-0.00
Channel Z	+ Input	20002.24	-1.53	-0.01
Channel Z	- Input	-20006.39	-1.21	0.01

Low Range		Reading (μV)	Difference (μV)	Error (%)
Channel X	+ Input	2000.59	-0.04	-0.00
Channel X	+ Input	201.05	0.35	0.17
Channel X	- Input	-198.64	0.66	-0.33
Channel Y	+ Input	2000.93	0.43	0.02
Channel Y	+ Input	200.09	-0.39	-0.19
Channel Y	- Input	-199.95	-0.46	0.23
Channel Z	+ Input	2000.45	-0.11	-0.01
Channel Z	+ Input	199.23	-1.27	-0.64
Channel Z	- Input	-200.99	-1.60	0.80

2. Common mode sensitivity

DASY measurement parameters: Auto Zero Time: 3 sec; Measuring time: 3 sec

	Common mode Input Voltage (mV)	High Range Average Reading (μV)	Low Range Average Reading (μV)
Channel X	200	-0.83	-2.31
	- 200	3.44	1.74
Channel Y	200	-13.76	-13.63
	- 200	12.11	11.98
Channel Z	200	-8.79	-9.23
	- 200	6.47	6.33

3. Channel separation

DASY measurement parameters: Auto Zero Time: 3 sec; Measuring time: 3 sec

	Input Voltage (mV)	Channel X (μV)	Channel Y (μV)	Channel Z (μV)
Channel X	200	-	3.73	-3.69
Channel Y	200	8.92	-	4.56
Channel Z	200	9.64	7.23	-

4. AD-Converter Values with inputs shorted

DASY measurement parameters: Auto Zero Time: 3 sec; Measuring time: 3 sec

	High Range (LSB)	Low Range (LSB)
Channel X	15956	15499
Channel Y	15857	16025
Channel Z	15899	16257

5. Input Offset Measurement

DASY measurement parameters: Auto Zero Time: 3 sec; Measuring time: 3 sec

Input 10M Ω

	Average (μ V)	min. Offset (μ V)	max. Offset (μ V)	Std. Deviation (μ V)
Channel X	0.88	-0.25	2.52	0.43
Channel Y	1.07	-1.41	2.26	0.49
Channel Z	-0.74	-1.63	0.51	0.41

6. Input Offset Current

Nominal Input circuitry offset current on all channels: <25fA

7. Input Resistance (Typical values for information)

	Zeroing (kOhm)	Measuring (MOhm)
Channel X	200	200
Channel Y	200	200
Channel Z	200	200

8. Low Battery Alarm Voltage (Typical values for information)

Typical values	Alarm Level (VDC)
Supply (+ Vcc)	+7.9
Supply (- Vcc)	-7.6

9. Power Consumption (Typical values for information)

Typical values	Switched off (mA)	Stand by (mA)	Transmitting (mA)
Supply (+ Vcc)	+0.01	+6	+14
Supply (- Vcc)	-0.01	-8	-9



Accredited by the Swiss Accreditation Service (SAS)
The Swiss Accreditation Service is one of the signatories to the EA
Multilateral Agreement for the recognition of calibration certificates

Accreditation No.: **SCS 108**

Client **Sporton-TW (Auden)**

Certificate No: **EX3-3976_Feb14**

CALIBRATION CERTIFICATE

Object **EX3DV4 - SN:3976**

Calibration procedure(s) **QA CAL-01.v9, QA CAL-14.v4, QA CAL-23.v5, QA CAL-25.v6
Calibration procedure for dosimetric E-field probes**

Calibration date: **February 17, 2014**

This calibration certificate documents the traceability to national standards, which realize the physical units of measurements (SI).
The measurements and the uncertainties with confidence probability are given on the following pages and are part of the certificate.

All calibrations have been conducted in the closed laboratory facility: environment temperature (22 ± 3)°C and humidity < 70%.

Calibration Equipment used (M&TE critical for calibration)

Primary Standards	ID	Cal Date (Certificate No.)	Scheduled Calibration
Power meter E4419B	GB41293874	04-Apr-13 (No. 217-01733)	Apr-14
Power sensor E4412A	MY41498087	04-Apr-13 (No. 217-01733)	Apr-14
Reference 3 dB Attenuator	SN: S5054 (3c)	04-Apr-13 (No. 217-01737)	Apr-14
Reference 20 dB Attenuator	SN: S5277 (20x)	04-Apr-13 (No. 217-01735)	Apr-14
Reference 30 dB Attenuator	SN: S5129 (30b)	04-Apr-13 (No. 217-01738)	Apr-14
Reference Probe ES3DV2	SN: 3013	30-Dec-13 (No. ES3-3013_Dec13)	Dec-14
DAE4	SN: 660	13-Dec-13 (No. DAE4-660_Dec13)	Dec-14
Secondary Standards	ID	Check Date (in house)	Scheduled Check
RF generator HP 8648C	US3642U01700	4-Aug-99 (in house check Apr-13)	In house check: Apr-16
Network Analyzer HP 8753E	US37390585	18-Oct-01 (in house check Oct-13)	In house check: Oct-14

	Name	Function	Signature
Calibrated by:	Jeton Kastrati	Laboratory Technician	
Approved by:	Katja Pokovic	Technical Manager	

Issued: February 19, 2014

This calibration certificate shall not be reproduced except in full without written approval of the laboratory.



Accredited by the Swiss Accreditation Service (SAS)

The Swiss Accreditation Service is one of the signatories to the EA
Multilateral Agreement for the recognition of calibration certificates

Accreditation No.: **SCS 108**

Glossary:

TSL	tissue simulating liquid
NORM _{x,y,z}	sensitivity in free space
ConvF	sensitivity in TSL / NORM _{x,y,z}
DCP	diode compression point
CF	crest factor (1/duty_cycle) of the RF signal
A, B, C, D	modulation dependent linearization parameters
Polarization φ	φ rotation around probe axis
Polarization ϑ	ϑ rotation around an axis that is in the plane normal to probe axis (at measurement center), i.e., $\vartheta = 0$ is normal to probe axis
Connector Angle	information used in DASY system to align probe sensor X to the robot coordinate system

Calibration is Performed According to the Following Standards:

- IEEE Std 1528-2013, "IEEE Recommended Practice for Determining the Peak Spatial-Averaged Specific Absorption Rate (SAR) in the Human Head from Wireless Communications Devices: Measurement Techniques", June 2013
- IEC 62209-1, "Procedure to measure the Specific Absorption Rate (SAR) for hand-held devices used in close proximity to the ear (frequency range of 300 MHz to 3 GHz)", February 2005

Methods Applied and Interpretation of Parameters:

- NORM_{x,y,z}**: Assessed for E-field polarization $\vartheta = 0$ ($f \leq 900$ MHz in TEM-cell; $f > 1800$ MHz: R22 waveguide). NORM_{x,y,z} are only intermediate values, i.e., the uncertainties of NORM_{x,y,z} does not affect the E²-field uncertainty inside TSL (see below ConvF).
- NORM(f)_{x,y,z} = NORM_{x,y,z} * frequency_response** (see Frequency Response Chart). This linearization is implemented in DASY4 software versions later than 4.2. The uncertainty of the frequency response is included in the stated uncertainty of ConvF.
- DCP_{x,y,z}**: DCP are numerical linearization parameters assessed based on the data of power sweep with CW signal (no uncertainty required). DCP does not depend on frequency nor media.
- PAR**: PAR is the Peak to Average Ratio that is not calibrated but determined based on the signal characteristics
- A_{x,y,z}; B_{x,y,z}; C_{x,y,z}; D_{x,y,z}; VR_{x,y,z}**: A, B, C, D are numerical linearization parameters assessed based on the data of power sweep for specific modulation signal. The parameters do not depend on frequency nor media. VR is the maximum calibration range expressed in RMS voltage across the diode.
- ConvF and Boundary Effect Parameters**: Assessed in flat phantom using E-field (or Temperature Transfer Standard for $f \leq 800$ MHz) and inside waveguide using analytical field distributions based on power measurements for $f > 800$ MHz. The same setups are used for assessment of the parameters applied for boundary compensation (alpha, depth) of which typical uncertainty values are given. These parameters are used in DASY4 software to improve probe accuracy close to the boundary. The sensitivity in TSL corresponds to NORM_{x,y,z} * ConvF whereby the uncertainty corresponds to that given for ConvF. A frequency dependent ConvF is used in DASY version 4.4 and higher which allows extending the validity from ± 50 MHz to ± 100 MHz.
- Spherical isotropy (3D deviation from isotropy)**: in a field of low gradients realized using a flat phantom exposed by a patch antenna.
- Sensor Offset**: The sensor offset corresponds to the offset of virtual measurement center from the probe tip (on probe axis). No tolerance required.
- Connector Angle**: The angle is assessed using the information gained by determining the NORM_x (no uncertainty required).

Probe EX3DV4

SN:3976

Manufactured: November 5, 2013
Calibrated: February 17, 2014

Calibrated for DASY/EASY Systems
(Note: non-compatible with DASY2 system!)

DASY/EASY - Parameters of Probe: EX3DV4 - SN:3976

Basic Calibration Parameters

	Sensor X	Sensor Y	Sensor Z	Unc (k=2)
Norm ($\mu\text{V}/(\text{V}/\text{m})^2$) ^A	0.49	0.51	0.55	$\pm 10.1 \%$
DCP (mV) ^B	100.4	99.2	98.0	

Modulation Calibration Parameters

UID	Communication System Name		A dB	B dB $\sqrt{\mu\text{V}}$	C	D dB	VR mV	Unc ^E (k=2)
0	CW	X	0.0	0.0	1.0	0.00	143.0	$\pm 2.5 \%$
		Y	0.0	0.0	1.0		132.3	
		Z	0.0	0.0	1.0		129.8	

The reported uncertainty of measurement is stated as the standard uncertainty of measurement multiplied by the coverage factor $k=2$, which for a normal distribution corresponds to a coverage probability of approximately 95%.

^A The uncertainties of NormX,Y,Z do not affect the E²-field uncertainty inside TSL (see Page 5).

^B Numerical linearization parameter: uncertainty not required.

^E Uncertainty is determined using the max. deviation from linear response applying rectangular distribution and is expressed for the square of the field value.

DASY/EASY - Parameters of Probe: EX3DV4 - SN:3976

Calibration Parameter Determined in Body Tissue Simulating Media

f (MHz) ^C	Relative Permittivity ^F	Conductivity (S/m) ^F	ConvF X	ConvF Y	ConvF Z	Alpha ^G	Depth (mm) ^G	Unct. (k=2)
750	55.5	0.96	10.12	10.12	10.12	0.27	1.15	± 12.0 %
835	55.2	0.97	10.00	10.00	10.00	0.50	0.78	± 12.0 %
900	55.0	1.05	9.78	9.78	9.78	0.25	1.21	± 12.0 %
1750	53.4	1.49	8.21	8.21	8.21	0.54	0.77	± 12.0 %
1900	53.3	1.52	7.89	7.89	7.89	0.27	1.12	± 12.0 %
2000	53.3	1.52	7.91	7.91	7.91	0.47	0.75	± 12.0 %
2450	52.7	1.95	7.40	7.40	7.40	0.80	0.58	± 12.0 %
2600	52.5	2.16	7.03	7.03	7.03	0.76	0.57	± 12.0 %
3500	37.9	2.91	6.79	6.79	6.79	0.37	1.14	± 13.1 %
3700	37.7	3.12	6.56	6.56	6.56	0.27	1.62	± 13.1 %
5200	36.0	4.66	4.61	4.61	4.61	0.45	1.90	± 13.1 %
5300	35.9	4.76	4.39	4.39	4.39	0.45	1.90	± 13.1 %
5500	35.6	4.96	4.17	4.17	4.17	0.45	1.90	± 13.1 %
5600	35.5	5.07	3.69	3.69	3.69	0.60	1.90	± 13.1 %
5800	35.3	5.27	4.26	4.26	4.26	0.50	1.90	± 13.1 %

^C Frequency validity of ± 100 MHz only applies for DASY v4.4 and higher (see Page 2), else it is restricted to ± 50 MHz. The uncertainty is the RSS of the ConvF uncertainty at calibration frequency and the uncertainty for the indicated frequency band.

^F At frequencies below 3 GHz, the validity of tissue parameters (ϵ and σ) can be relaxed to ± 10% if liquid compensation formula is applied to measured SAR values. At frequencies above 3 GHz, the validity of tissue parameters (ϵ and σ) is restricted to ± 5%. The uncertainty is the RSS of the ConvF uncertainty for indicated target tissue parameters.

^G Alpha/Depth are determined during calibration. SPEAG warrants that the remaining deviation due to the boundary effect after compensation is always less than ± 1% for frequencies below 3 GHz and below ± 2% for frequencies between 3-6 GHz at any distance larger than half the probe tip diameter from the boundary.

Frequency Response of E-Field (TEM-Cell:ifi1110 EXX, Waveguide: R22)

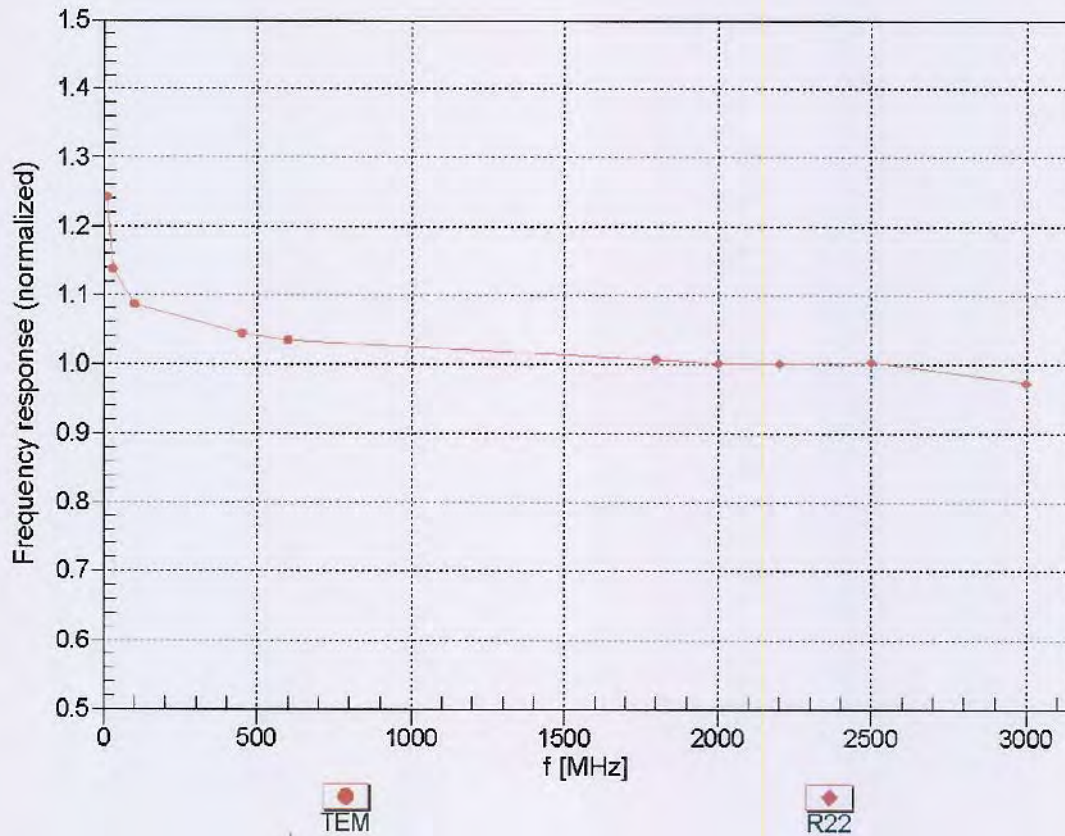

Uncertainty of Frequency Response of E-field: $\pm 6.3\%$ (k=2)

Receiving Pattern (ϕ), $\theta = 0^\circ$

f=600 MHz, TEM

f=1800 MHz, R22

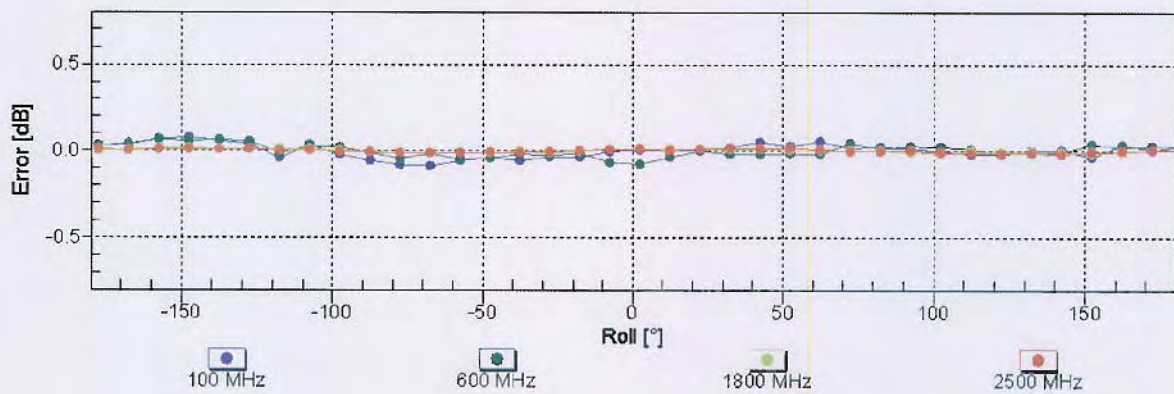
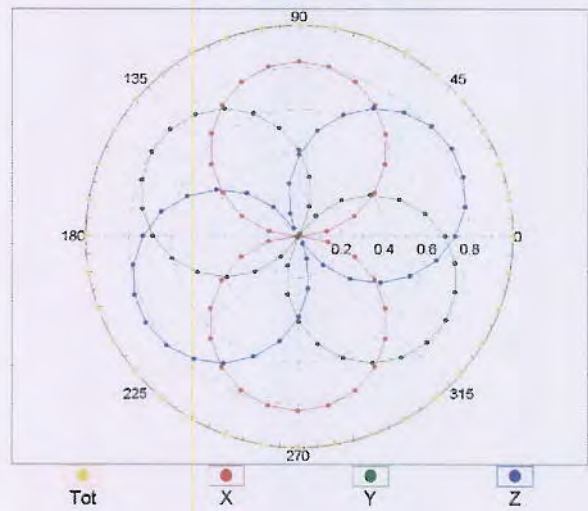
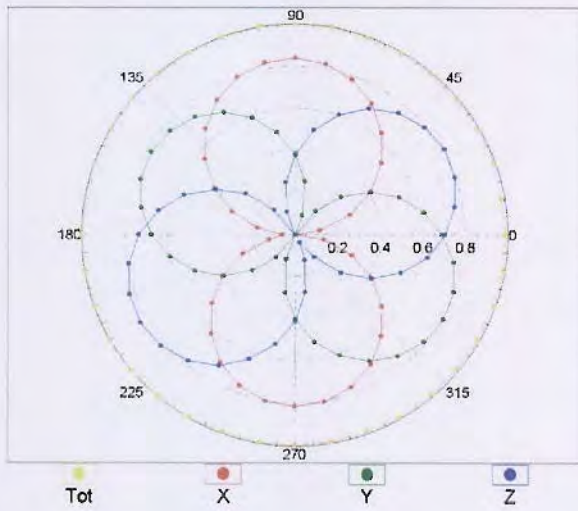

Uncertainty of Axial Isotropy Assessment: $\pm 0.5\%$ (k=2)

Dynamic Range $f(SAR_{head})$ (TEM cell , $f_{eval} = 1900$ MHz)

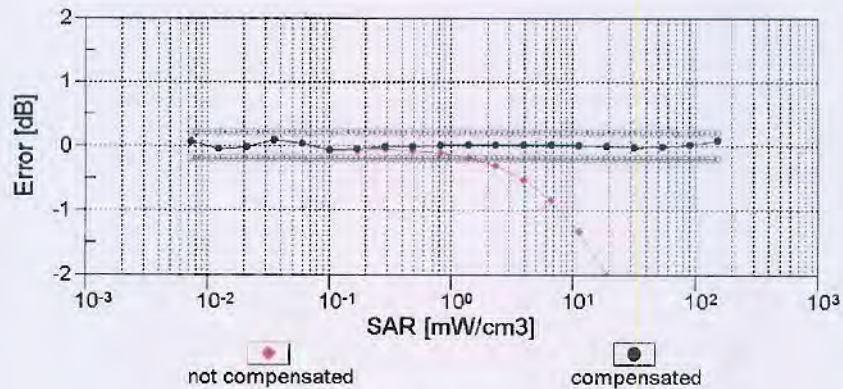
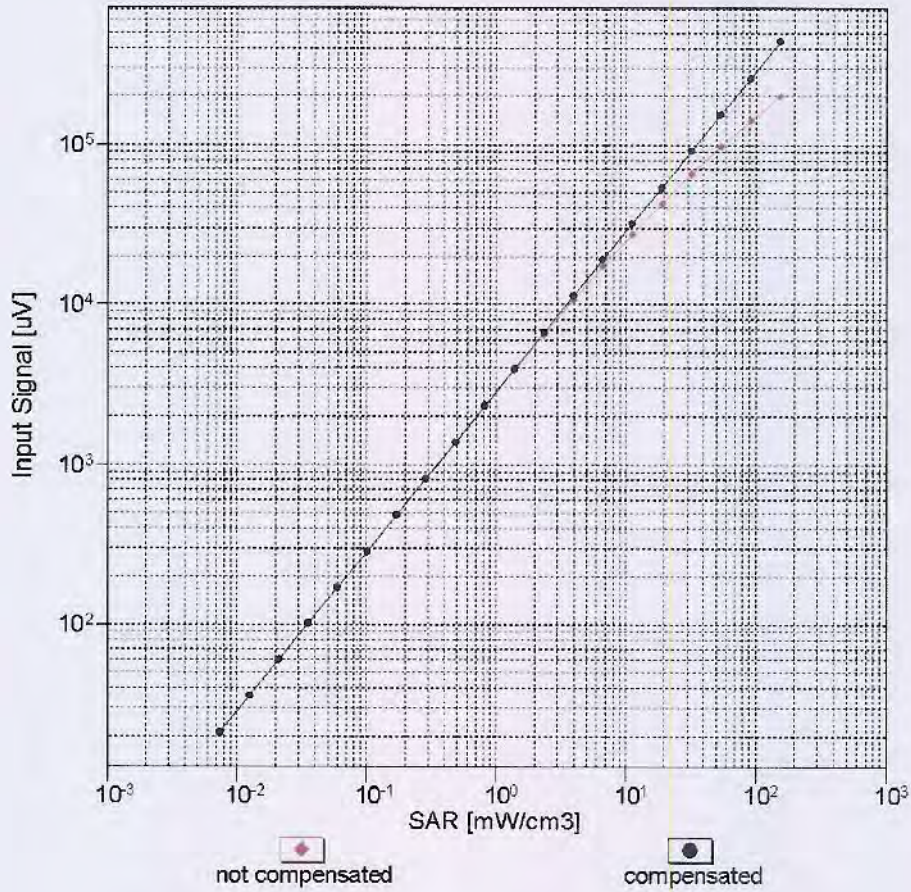

Uncertainty of Linearity Assessment: $\pm 0.6\%$ ($k=2$)

Conversion Factor Assessment

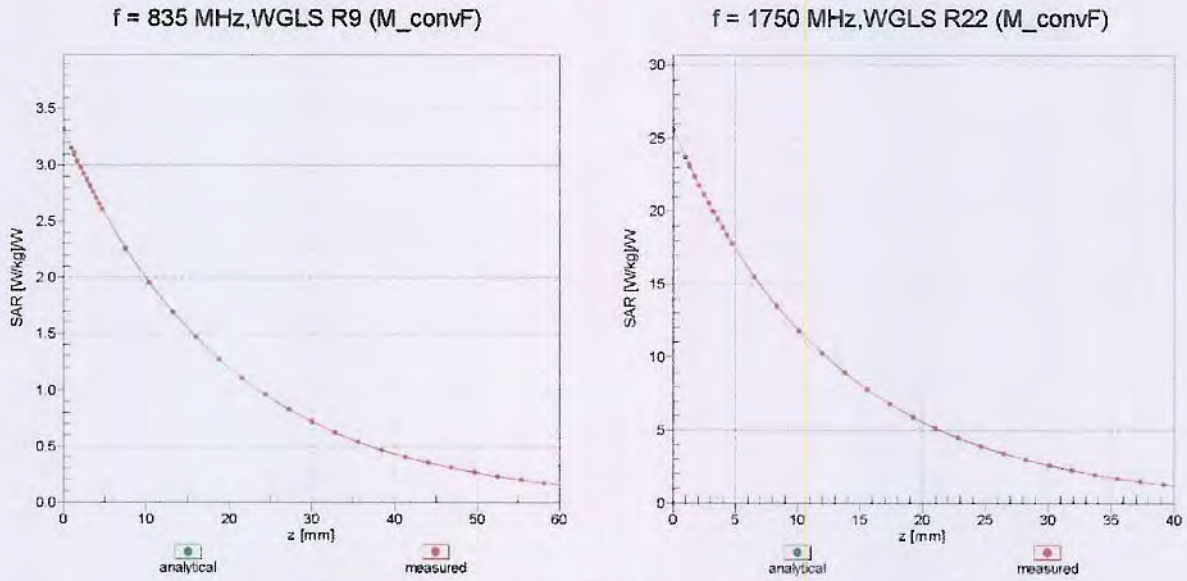

Deviation from Isotropy in Liquid Error (ϕ, ϑ), f = 900 MHz

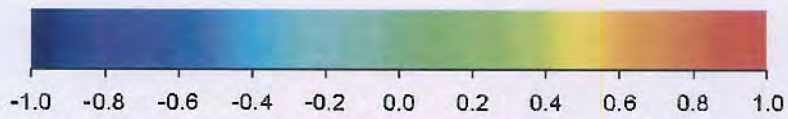
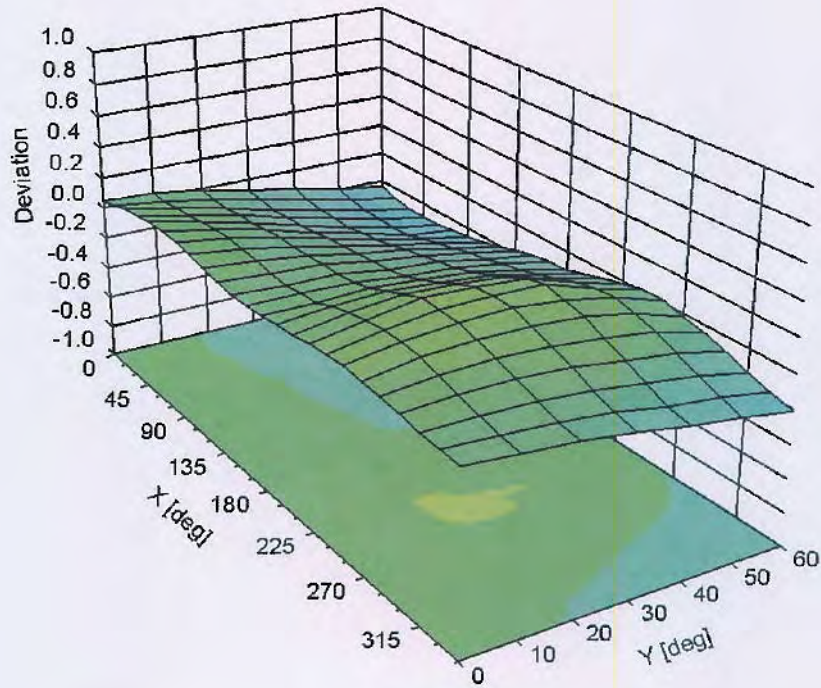

Uncertainty of Spherical Isotropy Assessment: $\pm 2.6\%$ (k=2)

DASY/EASY - Parameters of Probe: EX3DV4 - SN:3976

Other Probe Parameters

Sensor Arrangement	Triangular
Connector Angle (°)	-7.6
Mechanical Surface Detection Mode	enabled
Optical Surface Detection Mode	disabled
Probe Overall Length	337 mm
Probe Body Diameter	10 mm
Tip Length	9 mm
Tip Diameter	2.5 mm
Probe Tip to Sensor X Calibration Point	1 mm
Probe Tip to Sensor Y Calibration Point	1 mm
Probe Tip to Sensor Z Calibration Point	1 mm
Recommended Measurement Distance from Surface	2 mm



S
C
S

Schweizerischer Kalibrierdienst
Service suisse d'étalonnage
Servizio svizzero di taratura
Swiss Calibration Service

Accredited by the Swiss Accreditation Service (SAS)
The Swiss Accreditation Service is one of the signatories to the EA
Multilateral Agreement for the recognition of calibration certificates

Accreditation No.: **SCS 108**

Client **Sporton-TW (Auden)**

Certificate No: **D2450V2-929_Feb14**

CALIBRATION CERTIFICATE

Object **D2450V2 - SN: 929**

Calibration procedure(s) **QA CAL-05.v9
Calibration procedure for dipole validation kits above 700 MHz**

Calibration date: **February 12, 2014**

This calibration certificate documents the traceability to national standards, which realize the physical units of measurements (SI).
The measurements and the uncertainties with confidence probability are given on the following pages and are part of the certificate.

All calibrations have been conducted in the closed laboratory facility: environment temperature $(22 \pm 3)^\circ\text{C}$ and humidity $< 70\%$.

Calibration Equipment used (M&TE critical for calibration)

Primary Standards	ID #	Cal Date (Certificate No.)	Scheduled Calibration
Power meter EPM-442A	GB37480704	09-Oct-13 (No. 217-01827)	Oct-14
Power sensor HP 8481A	US37292783	09-Oct-13 (No. 217-01827)	Oct-14
Power sensor HP 8481A	MY41092317	09-Oct-13 (No. 217-01828)	Oct-14
Reference 20 dB Attenuator	SN: 5058 (20k)	04-Apr-13 (No. 217-01736)	Apr-14
Type-N mismatch combination	SN: 5047.3 / 06327	04-Apr-13 (No. 217-01739)	Apr-14
Reference Probe ES3DV3	SN: 3205	30-Dec-13 (No. ES3-3205_Dec13)	Dec-14
DAE4	SN: 601	25-Apr-13 (No. DAE4-601_Apr13)	Apr-14
Secondary Standards	ID #	Check Date (in house)	Scheduled Check
RF generator R&S SMT-06	100005	04-Aug-99 (in house check Oct-13)	In house check: Oct-16
Network Analyzer HP 8753E	US37390585 S4206	18-Oct-01 (in house check Oct-13)	In house check: Oct-14

Calibrated by: **Leif Klysner** Name: **Leif Klysner** Function: **Laboratory Technician**

Approved by: **Katja Pokovic** Name: **Katja Pokovic** Technical Manager

Signature

Issued: February 14, 2014

This calibration certificate shall not be reproduced except in full without written approval of the laboratory.



Accredited by the Swiss Accreditation Service (SAS)
The Swiss Accreditation Service is one of the signatories to the EA
Multilateral Agreement for the recognition of calibration certificates

Accreditation No.: **SCS 108**

Glossary:

TSL	tissue simulating liquid
ConvF	sensitivity in TSL / NORM x,y,z
N/A	not applicable or not measured

Calibration is Performed According to the Following Standards:

- IEEE Std 1528-2013, "IEEE Recommended Practice for Determining the Peak Spatial-Averaged Specific Absorption Rate (SAR) in the Human Head from Wireless Communications Devices: Measurement Techniques", June 2013
- IEC 62209-1, "Procedure to measure the Specific Absorption Rate (SAR) for hand-held devices used in close proximity to the ear (frequency range of 300 MHz to 3 GHz)", February 2005
- KDB 865664, "SAR Measurement Requirements for 100 MHz to 6 GHz"

Additional Documentation:

- DASY4/5 System Handbook

Methods Applied and Interpretation of Parameters:

- Measurement Conditions:* Further details are available from the Validation Report at the end of the certificate. All figures stated in the certificate are valid at the frequency indicated.
- Antenna Parameters with TSL:* The dipole is mounted with the spacer to position its feed point exactly below the center marking of the flat phantom section, with the arms oriented parallel to the body axis.
- Feed Point Impedance and Return Loss:* These parameters are measured with the dipole positioned under the liquid filled phantom. The impedance stated is transformed from the measurement at the SMA connector to the feed point. The Return Loss ensures low reflected power. No uncertainty required.
- Electrical Delay:* One-way delay between the SMA connector and the antenna feed point. No uncertainty required.
- SAR measured:* SAR measured at the stated antenna input power.
- SAR normalized:* SAR as measured, normalized to an input power of 1 W at the antenna connector.
- SAR for nominal TSL parameters:* The measured TSL parameters are used to calculate the nominal SAR result.

The reported uncertainty of measurement is stated as the standard uncertainty of measurement multiplied by the coverage factor $k=2$, which for a normal distribution corresponds to a coverage probability of approximately 95%.

Measurement Conditions

DASY system configuration, as far as not given on page 1.

DASY Version	DASY5	V52.8.7
Extrapolation	Advanced Extrapolation	
Phantom	Modular Flat Phantom	
Distance Dipole Center - TSL	10 mm	with Spacer
Zoom Scan Resolution	dx, dy, dz = 5 mm	
Frequency	2450 MHz \pm 1 MHz	

Body TSL parameters

The following parameters and calculations were applied.

	Temperature	Permittivity	Conductivity
Nominal Body TSL parameters	22.0 °C	52.7	1.95 mho/m
Measured Body TSL parameters	(22.0 \pm 0.2) °C	51.3 \pm 6 %	2.04 mho/m \pm 6 %
Body TSL temperature change during test	< 0.5 °C	----	----

SAR result with Body TSL

SAR averaged over 1 cm³ (1 g) of Body TSL	Condition	
SAR measured	250 mW input power	13.2 W/kg
SAR for nominal Body TSL parameters	normalized to 1W	51.4 W/kg \pm 17.0 % (k=2)

SAR averaged over 10 cm³ (10 g) of Body TSL	condition	
SAR measured	250 mW input power	6.06 W/kg
SAR for nominal Body TSL parameters	normalized to 1W	23.9 W/kg \pm 16.5 % (k=2)

Appendix

Antenna Parameters with Body TSL

Impedance, transformed to feed point	49.4 Ω + 4.7 j Ω
Return Loss	- 26.5 dB

General Antenna Parameters and Design

Electrical Delay (one direction)	1.125 ns
----------------------------------	----------

After long term use with 100W radiated power, only a slight warming of the dipole near the feedpoint can be measured.

The dipole is made of standard semirigid coaxial cable. The center conductor of the feeding line is directly connected to the second arm of the dipole. The antenna is therefore short-circuited for DC-signals. On some of the dipoles, small end caps are added to the dipole arms in order to improve matching when loaded according to the position as explained in the "Measurement Conditions" paragraph. The SAR data are not affected by this change. The overall dipole length is still according to the Standard.

No excessive force must be applied to the dipole arms, because they might bend or the soldered connections near the feedpoint may be damaged.

Additional EUT Data

Manufactured by	SPEAG
Manufactured on	September 26, 2013

DASY5 Validation Report for Body TSL

Date: 12.02.2014

Test Laboratory: SPEAG, Zurich, Switzerland

DUT: Dipole 2450 MHz; Type: D2450V2; Serial: D2450V2 - SN: 929

Communication System: UID 0 - CW; Frequency: 2450 MHz

Medium parameters used: $f = 2450$ MHz; $\sigma = 2.04$ S/m; $\epsilon_r = 51.3$; $\rho = 1000$ kg/m³

Phantom section: Flat Section

Measurement Standard: DASY5 (IEEE/IEC/ANSI C63.19-2007)

DASY52 Configuration:

- Probe: ES3DV3 - SN3205; ConvF(4.35, 4.35, 4.35); Calibrated: 30.12.2013;
- Sensor-Surface: 3mm (Mechanical Surface Detection)
- Electronics: DAE4 Sn601; Calibrated: 25.04.2013
- Phantom: Flat Phantom 5.0 (back); Type: QD000P50AA; Serial: 1002
- DASY52 52.8.7(1137); SEMCAD X 14.6.10(7164)

Dipole Calibration for Body Tissue/Pin=250 mW, d=10mm/Zoom Scan (7x7x7)/Cube 0:

Measurement grid: dx=5mm, dy=5mm, dz=5mm

Reference Value = 95.294 V/m; Power Drift = 0.03 dB

Peak SAR (extrapolated) = 27.6 W/kg

SAR(1 g) = 13.2 W/kg; SAR(10 g) = 6.06 W/kg

Maximum value of SAR (measured) = 17.5 W/kg

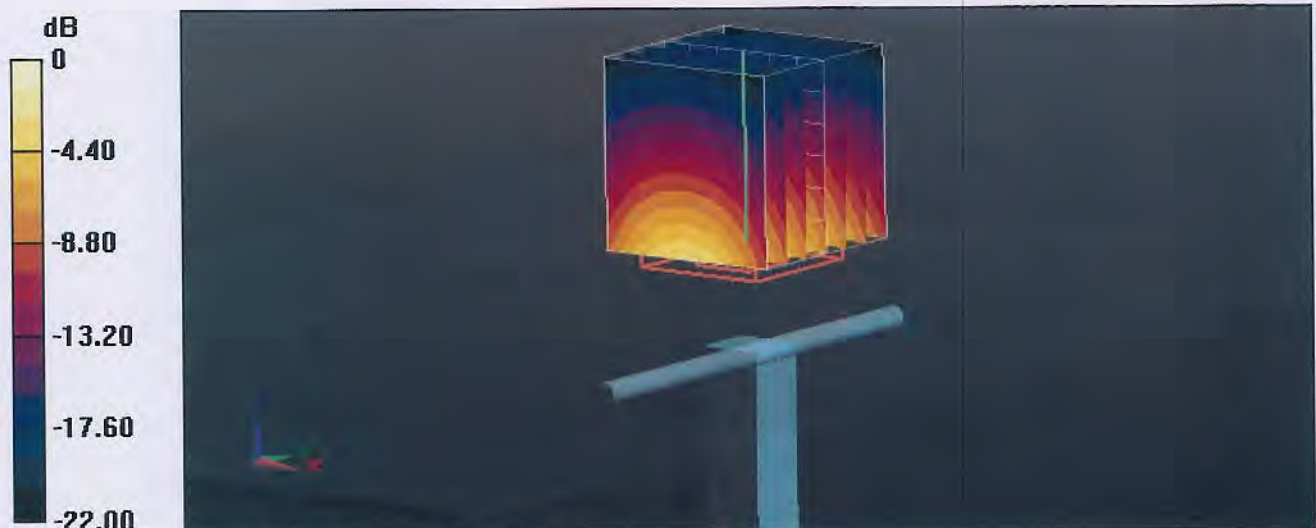

0 dB = 17.5 W/kg = 12.43 dBW/kg

Impedance Measurement Plot for Body TSL

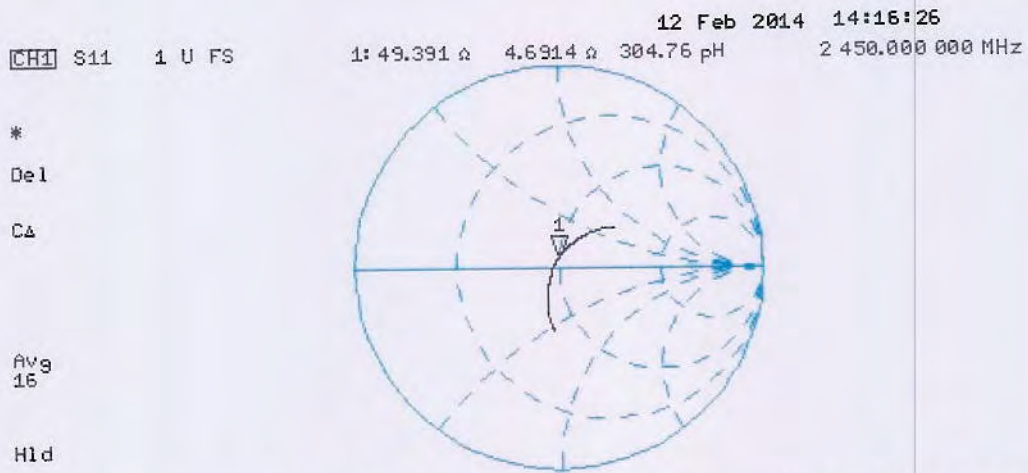



Accredited by the Swiss Accreditation Service (SAS)
The Swiss Accreditation Service is one of the signatories to the EA
Multilateral Agreement for the recognition of calibration certificates

Accreditation No.: **SCS 108**

Client **Sporton-TW (Auden)**

Certificate No: **D5GHzV2-1171_Feb14**

CALIBRATION CERTIFICATE

Object: **D5GHzV2 - SN: 1171**

Calibration procedure(s): **QA CAL-22.v2
Calibration procedure for dipole validation kits between 3-6 GHz**

Calibration date: **February 13, 2014**

This calibration certificate documents the traceability to national standards, which realize the physical units of measurements (SI).
The measurements and the uncertainties with confidence probability are given on the following pages and are part of the certificate.

All calibrations have been conducted in the closed laboratory facility: environment temperature (22 ± 3)°C and humidity < 70%.

Calibration Equipment used (M&TE critical for calibration)

Primary Standards	ID #	Cal Date (Certificate No.)	Scheduled Calibration
Power meter EPM-442A	GB37480704	09-Oct-13 (No. 217-01827)	Oct-14
Power sensor HP 8481A	US37292783	09-Oct-13 (No. 217-01827)	Oct-14
Power sensor HP 8481A	MY41092317	09-Oct-13 (No. 217-01828)	Oct-14
Reference 20 dB Attenuator	SN: 5058 (20k)	04-Apr-13 (No. 217-01736)	Apr-14
Type-N mismatch combination	SN: 5047.3 / 06327	04-Apr-13 (No. 217-01739)	Apr-14
Reference Probe EX3DV4	SN: 3503	30-Dec-13 (No. EX3-3503_Dec13)	Dec-14
DAE4	SN: 601	25-Apr-13 (No. DAE4-601_Apr13)	Apr-14
Secondary Standards	ID #	Check Date (in house)	Scheduled Check
RF generator R&S SMT-06	100005	04-Aug-99 (in house check Oct-13)	In house check: Oct-16
Network Analyzer HP 8753E	US37390585 S4206	18-Oct-01 (in house check Oct-13)	In house check: Oct-14

Calibrated by: **Claudio Leuler** (Name) / **Laboratory Technician** (Function)

Signature:

Approved by: **Katja Pokovic** (Name) / **Technical Manager** (Function)

Signature:

Issued: February 17, 2014

This calibration certificate shall not be reproduced except in full without written approval of the laboratory.



Accredited by the Swiss Accreditation Service (SAS)

The Swiss Accreditation Service is one of the signatories to the EA
Multilateral Agreement for the recognition of calibration certificates

Accreditation No.: **SCS 108**

Glossary:

TSL	tissue simulating liquid
ConvF	sensitivity in TSL / NORM x,y,z
N/A	not applicable or not measured

Calibration is Performed According to the Following Standards:

- IEC 62209-2, "Evaluation of Human Exposure to Radio Frequency Fields from Handheld and Body-Mounted Wireless Communication Devices in the Frequency Range of 30 MHz to 6 GHz: Human models, Instrumentation, and Procedures"; Part 2: "Procedure to determine the Specific Absorption Rate (SAR) for including accessories and multiple transmitters", March 2010
- KDB 865664, "SAR Measurement Requirements for 100 MHz to 6 GHz"
- IEEE Std 1528-2013, "IEEE Recommended Practice for Determining the Peak Spatial-Averaged Specific Absorption Rate (SAR) in the Human Head from Wireless Communications Devices: Measurement Techniques", June 2013

Additional Documentation:

- DASY4/5 System Handbook

Methods Applied and Interpretation of Parameters:

- Measurement Conditions:** Further details are available from the Validation Report at the end of the certificate. All figures stated in the certificate are valid at the frequency indicated.
- Antenna Parameters with TSL:** The dipole is mounted with the spacer to position its feed point exactly below the center marking of the flat phantom section, with the arms oriented parallel to the body axis.
- Feed Point Impedance and Return Loss:** These parameters are measured with the dipole positioned under the liquid filled phantom. The impedance stated is transformed from the measurement at the SMA connector to the feed point. The Return Loss ensures low reflected power. No uncertainty required.
- Electrical Delay:** One-way delay between the SMA connector and the antenna feed point. No uncertainty required.
- SAR measured:** SAR measured at the stated antenna input power.
- SAR normalized:** SAR as measured, normalized to an input power of 1 W at the antenna connector.
- SAR for nominal TSL parameters:** The measured TSL parameters are used to calculate the nominal SAR result.

The reported uncertainty of measurement is stated as the standard uncertainty of measurement multiplied by the coverage factor $k=2$, which for a normal distribution corresponds to a coverage probability of approximately 95%.

Measurement Conditions

DASY system configuration, as far as not given on page 1.

DASY Version	DASY5	V52.8.7
Extrapolation	Advanced Extrapolation	
Phantom	Modular Flat Phantom V5.0	
Distance Dipole Center - TSL	10 mm	with Spacer
Zoom Scan Resolution	dx, dy = 4.0 mm, dz = 1.4 mm	Graded Ratio = 1.4 (Z direction)
Frequency	5200 MHz ± 1 MHz 5300 MHz ± 1 MHz 5600 MHz ± 1 MHz 5800 MHz ± 1 MHz	

Body TSL parameters at 5200 MHz

The following parameters and calculations were applied.

	Temperature	Permittivity	Conductivity
Nominal Body TSL parameters	22.0 °C	49.0	5.30 mho/m
Measured Body TSL parameters	(22.0 ± 0.2) °C	47.8 ± 6 %	5.40 mho/m ± 6 %
Body TSL temperature change during test	< 0.5 °C	----	----

SAR result with Body TSL at 5200 MHz

SAR averaged over 1 cm³ (1 g) of Body TSL	Condition	
SAR measured	100 mW input power	7.43 W/kg
SAR for nominal Body TSL parameters	normalized to 1W	74.0 W/kg ± 19.9 % (k=2)

SAR averaged over 10 cm³ (10 g) of Body TSL	condition	
SAR measured	100 mW input power	2.08 W/kg
SAR for nominal Body TSL parameters	normalized to 1W	20.7 W/kg ± 19.5 % (k=2)

Body TSL parameters at 5300 MHz

The following parameters and calculations were applied.

	Temperature	Permittivity	Conductivity
Nominal Body TSL parameters	22.0 °C	48.9	5.42 mho/m
Measured Body TSL parameters	(22.0 ± 0.2) °C	47.6 ± 6 %	5.53 mho/m ± 6 %
Body TSL temperature change during test	< 0.5 °C	----	----

SAR result with Body TSL at 5300 MHz

SAR averaged over 1 cm ³ (1 g) of Body TSL	Condition	
SAR measured	100 mW input power	7.55 W/kg
SAR for nominal Body TSL parameters	normalized to 1W	75.1 W/kg ± 19.9 % (k=2)

SAR averaged over 10 cm ³ (10 g) of Body TSL	condition	
SAR measured	100 mW input power	2.12 W/kg
SAR for nominal Body TSL parameters	normalized to 1W	21.1 W/kg ± 19.5 % (k=2)

Body TSL parameters at 5600 MHz

The following parameters and calculations were applied.

	Temperature	Permittivity	Conductivity
Nominal Body TSL parameters	22.0 °C	48.5	5.77 mho/m
Measured Body TSL parameters	(22.0 ± 0.2) °C	47.1 ± 6 %	5.94 mho/m ± 6 %
Body TSL temperature change during test	< 0.5 °C	----	----

SAR result with Body TSL at 5600 MHz

SAR averaged over 1 cm ³ (1 g) of Body TSL	Condition	
SAR measured	100 mW input power	8.01 W/kg
SAR for nominal Body TSL parameters	normalized to 1W	79.7 W/kg ± 19.9 % (k=2)

SAR averaged over 10 cm ³ (10 g) of Body TSL	condition	
SAR measured	100 mW input power	2.22 W/kg
SAR for nominal Body TSL parameters	normalized to 1W	22.1 W/kg ± 19.5 % (k=2)

Body TSL parameters at 5800 MHz

The following parameters and calculations were applied.

	Temperature	Permittivity	Conductivity
Nominal Body TSL parameters	22.0 °C	48.2	6.00 mho/m
Measured Body TSL parameters	(22.0 ± 0.2) °C	46.8 ± 6 %	6.21 mho/m ± 6 %
Body TSL temperature change during test	< 0.5 °C	----	----

SAR result with Body TSL at 5800 MHz

SAR averaged over 1 cm ³ (1 g) of Body TSL	Condition	
SAR measured	100 mW input power	7.44 W/kg
SAR for nominal Body TSL parameters	normalized to 1W	74.1 W/kg ± 19.9 % (k=2)

SAR averaged over 10 cm ³ (10 g) of Body TSL	condition	
SAR measured	100 mW input power	2.06 W/kg
SAR for nominal Body TSL parameters	normalized to 1W	20.5 W/kg ± 19.5 % (k=2)

Appendix

Antenna Parameters with Body TSL at 5200 MHz

Impedance, transformed to feed point	49.3 Ω - 9.0 j Ω
Return Loss	- 20.9 dB

Antenna Parameters with Body TSL at 5300 MHz

Impedance, transformed to feed point	51.1 Ω - 5.3 j Ω
Return Loss	- 25.4 dB

Antenna Parameters with Body TSL at 5600 MHz

Impedance, transformed to feed point	54.8 Ω - 4.3 j Ω
Return Loss	- 24.2 dB

Antenna Parameters with Body TSL at 5800 MHz

Impedance, transformed to feed point	56.1 Ω - 2.7 j Ω
Return Loss	- 24.0 dB

General Antenna Parameters and Design

Electrical Delay (one direction)	1.204 ns
----------------------------------	----------

After long term use with 100W radiated power, only a slight warming of the dipole near the feedpoint can be measured.

The dipole is made of standard semirigid coaxial cable. The center conductor of the feeding line is directly connected to the second arm of the dipole. The antenna is therefore short-circuited for DC-signals. On some of the dipoles, small end caps are added to the dipole arms in order to improve matching when loaded according to the position as explained in the "Measurement Conditions" paragraph. The SAR data are not affected by this change. The overall dipole length is still according to the Standard.

No excessive force must be applied to the dipole arms, because they might bend or the soldered connections near the feedpoint may be damaged.

Additional EUT Data

Manufactured by	SPEAG
Manufactured on	December 09, 2013

DASY5 Validation Report for Body TSL

Date: 13.02.2014

Test Laboratory: SPEAG, Zurich, Switzerland

DUT: Dipole 5GHz; Type: D5GHzV2; Serial: D5GHzV2 - SN: 1171

Communication System: UID 0 - CW; Frequency: 5200 MHz, Frequency: 5300 MHz, Frequency: 5600 MHz, Frequency: 5800 MHz

Medium parameters used: $f = 5200$ MHz; $\sigma = 5.4$ S/m; $\epsilon_r = 47.8$; $\rho = 1000$ kg/m³, Medium parameters used: $f = 5300$ MHz; $\sigma = 5.53$ S/m; $\epsilon_r = 47.6$; $\rho = 1000$ kg/m³, Medium parameters used: $f = 5600$ MHz; $\sigma = 5.94$ S/m; $\epsilon_r = 47.1$; $\rho = 1000$ kg/m³, Medium parameters used: $f = 5800$ MHz; $\sigma = 6.21$ S/m; $\epsilon_r = 46.8$; $\rho = 1000$ kg/m³

Phantom section: Flat Section

Measurement Standard: DASY5 (IEEE/IEC/ANSI C63.19-2007)

DASY52 Configuration:

- Probe: EX3DV4 - SN3503; ConvF(5.01, 5.01, 5.01); Calibrated: 30.12.2013, ConvF(4.76, 4.76, 4.76); Calibrated: 30.12.2013, ConvF(4.3, 4.3, 4.3); Calibrated: 30.12.2013, ConvF(4.47, 4.47, 4.47); Calibrated: 30.12.2013;
- Sensor-Surface: 1.4mm (Mechanical Surface Detection)
- Electronics: DAE4 Sn601; Calibrated: 25.04.2013
- Phantom: Flat Phantom 5.0 (back); Type: QD000P50AA; Serial: 1002
- DASY52 52.8.7(1137); SEMCAD X 14.6.10(7164)

Dipole Calibration for Body Tissue/Pin=100mW, dist=10mm, f=5200 MHz/Zoom Scan, dist=1.4mm (8x8x7)/Cube 0: Measurement grid: dx=4mm, dy=4mm, dz=1.4mm

Reference Value = 58.329 V/m; Power Drift = -0.04 dB

Peak SAR (extrapolated) = 29.5 W/kg

SAR(1 g) = 7.43 W/kg; SAR(10 g) = 2.08 W/kg

Maximum value of SAR (measured) = 17.3 W/kg

Dipole Calibration for Body Tissue/Pin=100mW, dist=10mm, f=5300 MHz/Zoom Scan, dist=1.4mm (8x8x7)/Cube 0: Measurement grid: dx=4mm, dy=4mm, dz=1.4mm

Reference Value = 58.232 V/m; Power Drift = -0.05 dB

Peak SAR (extrapolated) = 30.8 W/kg

SAR(1 g) = 7.55 W/kg; SAR(10 g) = 2.12 W/kg

Maximum value of SAR (measured) = 17.8 W/kg

Dipole Calibration for Body Tissue/Pin=100mW, dist=10mm, f=5600 MHz/Zoom Scan, dist=1.4mm (8x8x7)/Cube 0: Measurement grid: dx=4mm, dy=4mm, dz=1.4mm

Reference Value = 58.298 V/m; Power Drift = -0.05 dB

Peak SAR (extrapolated) = 35.9 W/kg

SAR(1 g) = 8.01 W/kg; SAR(10 g) = 2.22 W/kg

Maximum value of SAR (measured) = 19.5 W/kg

Dipole Calibration for Body Tissue/Pin=100mW, dist=10mm, f=5800 MHz/Zoom Scan, dist=1.4mm (8x8x7)/Cube 0: Measurement grid: dx=4mm, dy=4mm, dz=1.4mm
Reference Value = 54.894 V/m; Power Drift = -0.03 dB
Peak SAR (extrapolated) = 35.0 W/kg
SAR(1 g) = 7.44 W/kg; SAR(10 g) = 2.06 W/kg
Maximum value of SAR (measured) = 18.3 W/kg

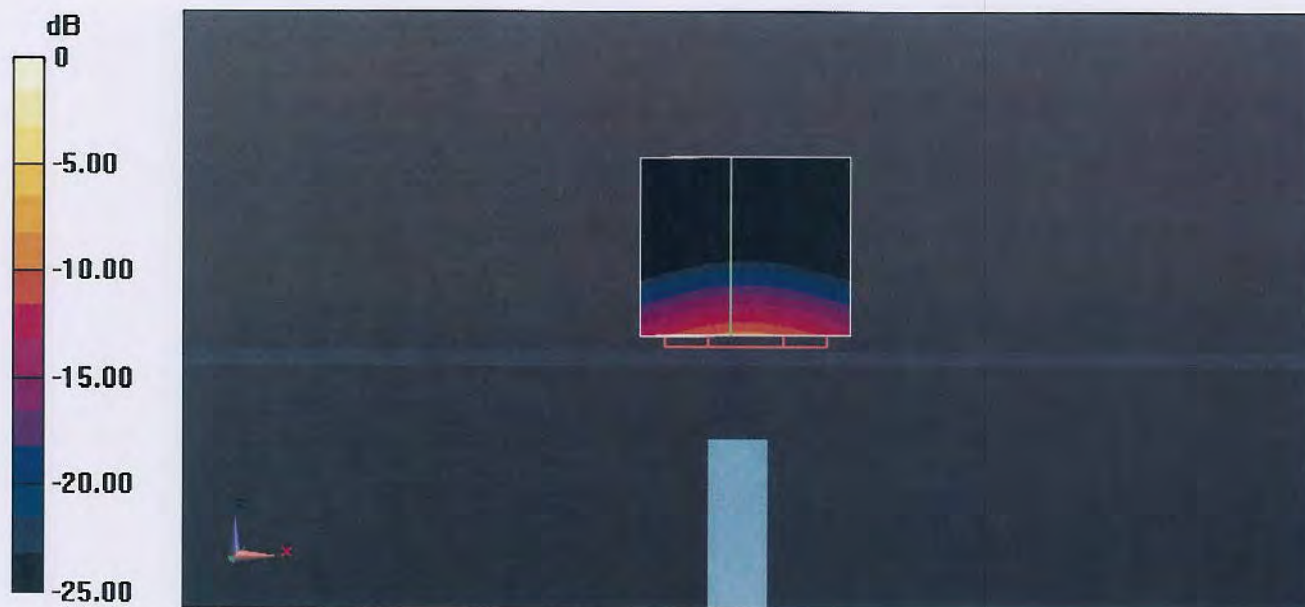

0 dB = 18.3 W/kg = 12.62 dBW/kg

Impedance Measurement Plot for Body TSL

13 Feb 2014 16:03:54

CH1 S11 1 U FS 1: 49.293 Ω -8.9512 Ω 3.4193 pF 5 200.000 000 MHz

*
Del
Cor
Avg
16
H1d

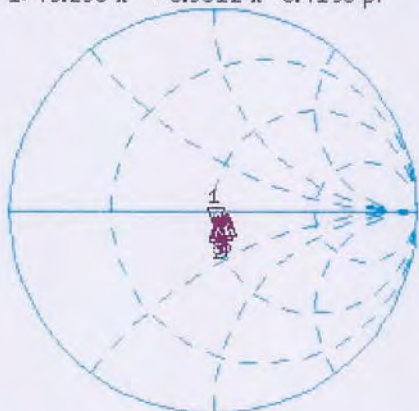

CH1 Markers
2: 51.084 Ω
-5.3164 Ω
5.30000 GHz
3: 51.566 Ω
-2.9824 Ω
5.50000 GHz
4: 54.840 Ω
-4.2539 Ω
5.60000 GHz
5: 56.082 Ω
-2.7227 Ω
5.80000 GHz

CH2 S11 LOG 5 dB/REF -20 dB 1:-20.907 dB 5 200.000 000 MHz

Cor
Avg
16
H1d

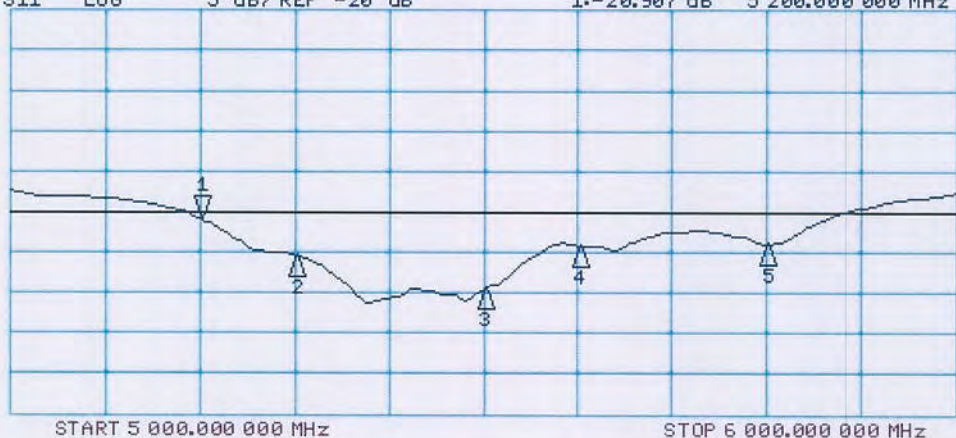

CH2 Markers
2: -25.412 dB
5.30000 GHz
3: -29.592 dB
5.50000 GHz
4: -24.228 dB
5.60000 GHz
5: -24.044 dB
5.80000 GHz