



EXHIBIT B

Test Report

Report No.	M1274982
Specifications	FCC Part 74 – Certification
Test Method	ANSI C63.4 1992
Applicant address	NO. 85, CHANG HSING FIRST STREET, TAI-TZU VILLAGE, JEN-TE HSIAN, TAINAN HSIEN , TAIWAN, R.O.C.
Applicant	WA-GOL INDUSTRIAL CO., LTD.
Items tested	Wireless Microphone
Model No.	UF-16 (Sample # M12982)
Results	Compliance (As detailed within this report)
Date	07/11/2000 (month / day / year)(Sample received) 07/18/2000 (month / day / year)(Test)
Prepared by	 Project Engineer
Authorized by	 General Manager (Frank Tsai)
Issue date	August 15, 2000 (month / day / year)
Modifications	None
Tested by	Training Research Co., Ltd.
Office at	2, Lane 194, Huan-Ho Street, Hsichih, Taipei Hsien 221, Taiwan
Anechoic Chamber at	2, Lane 194, Huan-Ho Street, Hsichih, Taipei Hsien 221, Taiwan

Conditions of issue:

- (1) This test report shall not be reproduced except in full, without written approval of TRC. And the test result contained within this report only relate to the sample submitted for testing.
- (2) This report must not be used by the client to claim product endorsement by NVLAP or nay agency of U.S. Government.

★ FCC ID : JEBUF-16

Contents

Chapter 0	Application for Certification	4
Chapter 1	General	
1.1	Introduction	5
1.2	Description of Support Equipment	5
1.3	Configuration of System Under Test	6
1.4	Location of the Measurement Site	6
1.5	General Test Condition	6
Chapter 2	Power Output Measurement	
2.1	Rules and Specification Limits	7
2.2	Measurement Condition and Setup	7
2.3	List of Measurement Instrument	8
2.4	Measurement Configuration	9
2.5	Measurement Result	10
Chapter 3	Modulation Characteristics Measurement	
3.1	Rules and Specification Limits	11
3.2	Test Configuration & List of Test Instruments	11
3.3	Measurement Condition & Setup	12
3.4	Frequency Response of Audio Low Pass Filter Measurement Condition & Setup	12
3.5	Modulation Limiting Measurement Condition & Setup	12
Chapter 4	Occupied Bandwidth Measurement & Calculation	
4.1	Rules and Specification Limits	15
4.2	Test Condition & Test Instruments	15
4.3	Measurement Procedure	16
4.4	Measurement Result	16

Chapter 5 Field Strength of Spurious Radiation Measurement

5.1 Rules and Specification Limits..... 17
5.2 Measurement Condition & Setup..... 17
5.3 List of Measurement Instruments..... 18
5.4 Measurement Configuration..... 19
5.5 Measurement Result 21

Chapter 6 Frequency Stability Tolerance Measurement

6.1 Rules and Specification limits 33
6.2 Measurement Condition & Setup with Temperature Variation..... 33
6.3 List of Measurement Instruments with Temperature Variation 33
6.4 Measurement Configuration with Temperature Variation..... 34
6.5 Measurement Result with Temperature Variation..... 35
6.6 Measurement Condition & Setup with Voltage Variation..... 36
6.7 List of Measurement Instruments with Voltage Variation..... 36
6.8 Measurement Configuration with Voltage Variation 36
6.9 Measurement Result with Voltage Variation 37

Chapter 0 Application for Certification

- 2.1033 (c)(1) : **WA-GOL INDUSTRIAL CO., LTD.**– applicant and manufacturer
- 2.1033 (c)(2) : The equipment is a transmitter, wireless microphone
Model No.: UF-16
- 2.1033 (c)(3) : Quantity production is planned. See Exhibit C.
- 2.1033 (c)(4) : Type of emission – F3E- FM Modulation
- 2.1033 (c)(5) : 100Hz ~ 26.98KHz
- 2.1033 (c)(6) : 1.436 mW
- 2.1033 (c)(7) : Specification of 250 mW is met by the equipment in the applicable part 74.861 (e)(1)
- 2.1033 (c)(8) : Final RF amplifier stage current : 3V, UM-3*2
- 2.1033 (c)(9) : Description follows
- 2.1033 (c)(10) : Complete circuit diagrams are included. No modification was made
- 2.1033 (c)(11) : See Exhibit A. Instruction sheet to user included
- 2.1033 (c)(12) : See Exhibit F.
- 2.1033 (c)(13) : N/A
- 2.1033 (c)(14) : Description follows.
- 2.1033 (c)(15) : N/A
- 2.1033 (c)(16) : N/A
- 2.1033 (c)(17) : N/A

Chapter 1 GENERAL

1.1 Introduction :

The following measurement report is submitted on behalf of **WA-GOL INDUSTRIAL CO., LTD.** in support of a wireless microphone certification in accordance with FCC Rules. 2.1031, 2.1046, 2.1047, 2.1049, 2.1053, 2.1055, 74.801 and 74.861.

Description of EUT :

EUT	:	WIRELESS MICROPHONE
Model No.	:	UF-16
Carrier Frequency Range	:	790 ~ 806 MHz
RF Power Output	:	1.436 mW
Supply Voltage	:	DC 3V
Supply Current	:	65 mA
Frequency Response	:	100Hz ~ 26.98KHz
Frequency Stability	:	0.005%
Operating Temperature	:	- 30 to + 50 degree centigrade

Wireless microphone is a transmitter which operates in the frequency range of 790 ~ 806 MHz. (790.375MHz, 798.375MHz and 805.375MHz tested) This microphone is worn by a performer and other participants in a program, filming, reporting ...etc.

1.2 Description of Support Equipment :

N/A

1.3 Configuration of test setup

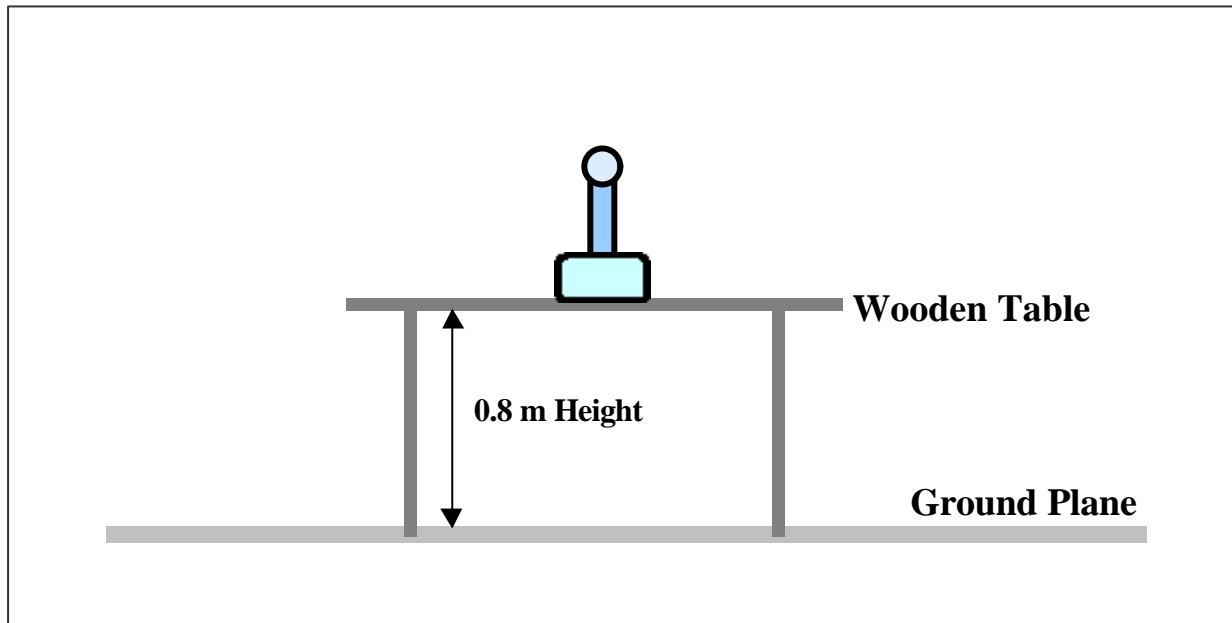

1.4 Location of the Measurement Site :

The radiated emissions measurements required by the Rules were performed on the Three-meter, anechoic chamber at test site maintained by **Training Research Co., Ltd.**, No. 2, Lane 194, Huan-Ho Street, Hsichih, Taipei Hsien 221, Taiwan. Complete description and measurement data have been placed on file with the Commission. The conducted power line Emissions tests were performed in a shielded enclosure also located at the above facility.

Training Research Co., Ltd. is listed by the FCC (Registration Number: 93906) as a facility available to do measurement work for others on a contract basis.

1.5 General Test Condition :

The conditions under which the EUT operates were varied to determine their effect on the equipment's emission characteristics. The final configuration of the test system and the mode of operation used during these tests were chosen as that which produced the highest emission levels. However, only those conditions, which the EUT was considered likely to encounter in normal use were investigated.

Chapter 2 Power Output Measurement

2.1 Rules and Specification Limits

2.1046

74.861 (e)(1) : The power of the measured unmodulated carrier power at output of the transmitter power amplifier (antenna input power) may not exceed the following:

1. 54 – 72, 76 – 88 and 174 – 216 MHz band 50 mW.
2. 470 – 608 AND 614 – 806 MHz band 250 mW.

2.2 Test condition and setup :

1. Measurement was made on open-field test site. The EUT system was placed on non-conductive turntable which is 0.8 meters height, top surface 1.0 X 1.5 meter. The EUT was placed in three direction of the space in order to obtain maximum emission.
2. A SCHAFFNER whole range antenna with horizontal and vertical polarization was raised from 1 – 4 meter as well as the turntable was rotate from 0 to 360 degree to search for the maximum Field Strength Spectrum where the spectrum analyzer was operated in the quasi-peak detection mode. Recorded all the values, which measured under horizontal and vertical position for the biconical antenna.
3. The following procedures were used to convert the emission levels measured in decibels referenced to 1 micro volt (dBμV) into field intensity in Watt.
 - (1) The actual field intensity in decibels referenced to 1 micro volt per meter (dBμV/m) is determined by algebraically adding the measured reading in dBμV, the antenna factor (dB), and cable loss (dB) at the appropriate frequency.
 - (2) The field intensity in Volt can then be determined by the following equation:

$$FI(\text{Volt}) = 10^{FI(\text{dB}\mu\text{V}/\text{m}) / 20} \times 10^{-6}$$

$$FI_a(\text{dBmV}/\text{m}) = FI_r(\text{dBmV}) - \text{Corrected (dB)}$$

$$\text{Corrected (dB)} = AF(\text{dB}) + [CL(\text{dB}) - \text{Amplitude Gain}]$$

FI_a : Actual Field Intensity

FI_r : Reading of the Field Intensity

AF : Antenna Factor

CL : Cable Loss

The field intensity in Watt can then be determined by the following equation :

$$P \text{ (watt)} = FI^2 \text{ (Volt)} \times d^2 \text{ (meter)} / 49.2$$

P : Power in Watt

D : Measurement Distance (3 m)

2.3 List of test Instrument :

<u>Instrument Name</u>	<u>Model No.</u>	<u>Brand</u>	<u>Serial No.</u>	<u>Calibration Date</u>	
				<u>Last time</u>	<u>Next time</u>
EMI Receiver	8546A	H P	3520A00242	10/01/99	10/01/00
RF Filter Section	85460A	H P	3448A00217	10/01/99	10/01/00
Bi-log Antenna	CBL6141A	Schaffner	4151	06/28/00	06/28/01
Switch/Control Unit (> 30MHz)	3488A	HP	N/A	11/20/99	11/20/00
Auto Switch Box (> 30MHz)	ASB-01	TRC	9904-01	11/20/99	11/20/20
Spectrum Analyzer	8564E	HP	US36433002	08/03/99	08/03/00
Microwave Preamplifier	83051A	HP	3232A00347	08/04/99	08/04/00
Horn Antenna	3115	EMCO	9704 – 5178	08/09/99	08/09/00

The level of confidence of 95%, the uncertainty of measurement of radiated emission is ± 4.96 dB.

2.4 Measurement Configuration

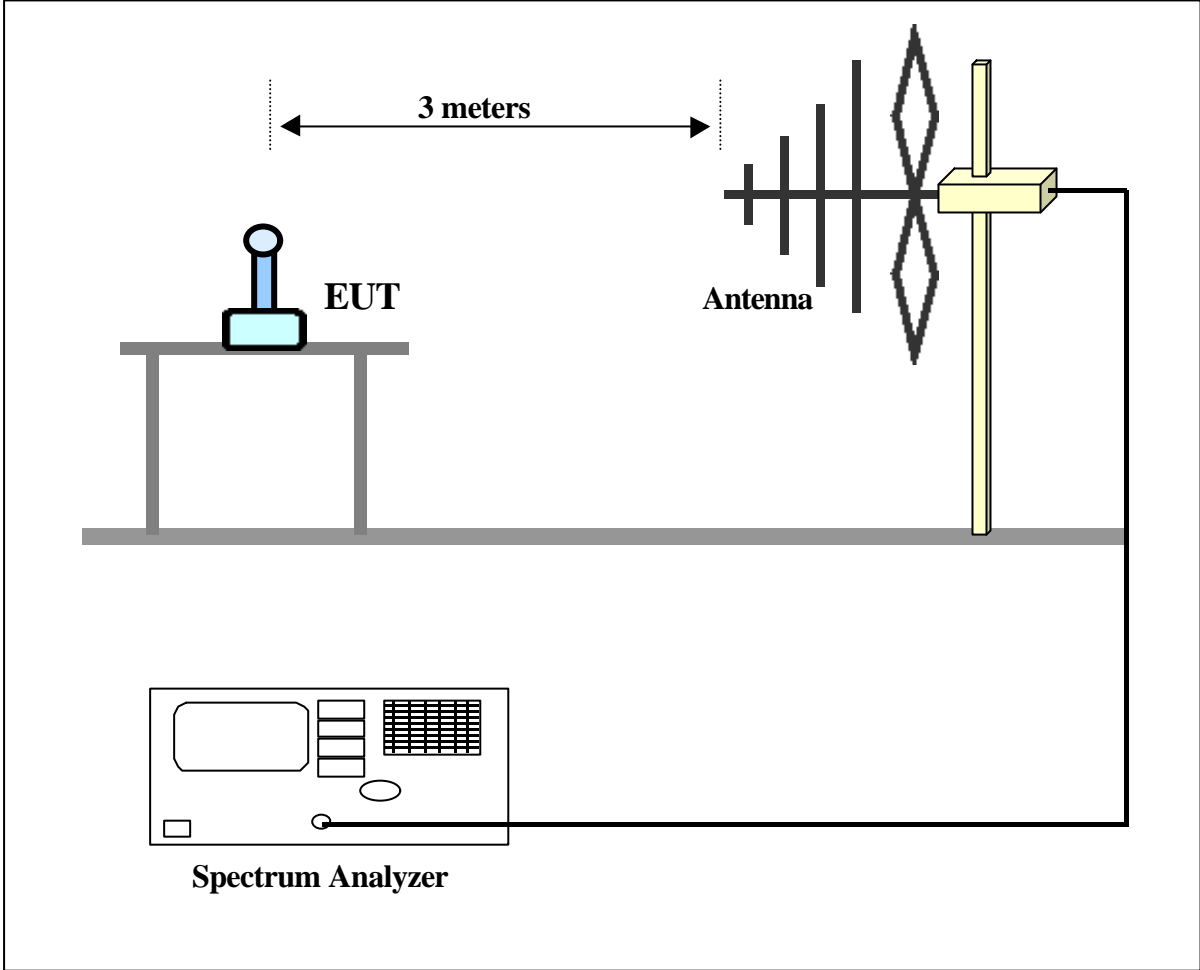

2.5 Measurement Result

(1) Frequency: 790.375 MHz

$$\begin{aligned} \text{Corrected (dB)} &= \text{AF(dB)} + [\text{CL(dB)} - \text{Amplitude Gain}] \\ &= -26.14 \text{ dB/m} \end{aligned}$$

$$\begin{aligned} \text{FI}_a \text{ (dBmV/m)} &= \text{FI}_r \text{ (DbmV)} - \text{Corrected (dB)} \\ &= 72.55 - (-26.14) \\ &= 98.69 \text{ dB}\mu\text{V/m} \end{aligned}$$

The maximum field measured is 98.69 dB μ V/m

$$\text{FI (Volt)} = 10^{98.69/20} \times 10^{-6} = 0.08600 \text{ V}$$

$$\text{FI (mW)} = (0.08600 \times 3)^2 / 49.2 = 1.352936 \text{ mW}$$

(2) Frequency: 798.375 MHz

$$\begin{aligned} \text{Corrected (dB)} &= \text{AF(dB)} + [\text{CL(dB)} - \text{Amplitude Gain}] \\ &= -26.26 \text{ dB/m} \end{aligned}$$

$$\begin{aligned} \text{FI}_a \text{ (dBmV/m)} &= \text{FI}_r \text{ (DbmV)} - \text{Corrected (dB)} \\ &= 72.69 - (-26.26) \\ &= 98.95 \text{ dB}\mu\text{V/m} \end{aligned}$$

The maximum field measured is 98.95 dB μ V/m

$$\text{FI (Volt)} = 10^{98.95/20} \times 10^{-6} = 0.08861 \text{ V}$$

$$\text{FI (mW)} = (0.08861 \times 3)^2 / 49.2 = 1.436407 \text{ mW}$$

(3) Frequency: 805.375 MHz

$$\begin{aligned} \text{Corrected (dB)} &= \text{AF(dB)} + [\text{CL(dB)} - \text{Amplitude Gain}] \\ &= -26.16 \text{ dB/m} \end{aligned}$$

$$\begin{aligned} \text{FI}_a \text{ (dBmV/m)} &= \text{FI}_r \text{ (DbmV)} - \text{Corrected (dB)} \\ &= 71.45 - (-26.16) \\ &= 97.61 \text{ dB}\mu\text{V/m} \end{aligned}$$

The maximum field measured is 97.61 dB μ V/m

$$\text{FI (Volt)} = 10^{97.61/20} \times 10^{-6} = 0.07595 \text{ V}$$

$$\text{FI (mW)} = (0.07595 \times 3)^2 / 49.2 = 1.055061 \text{ mW}$$

Chapter 3 Modulation Characteristics Measurement

3.1 Rules and Specification Limits

- 2.1047 (a): Voice modulated communication equipment
- (b): Equipment which employs modulation limiting

3.2 Test Configuration & List of Test Instruments

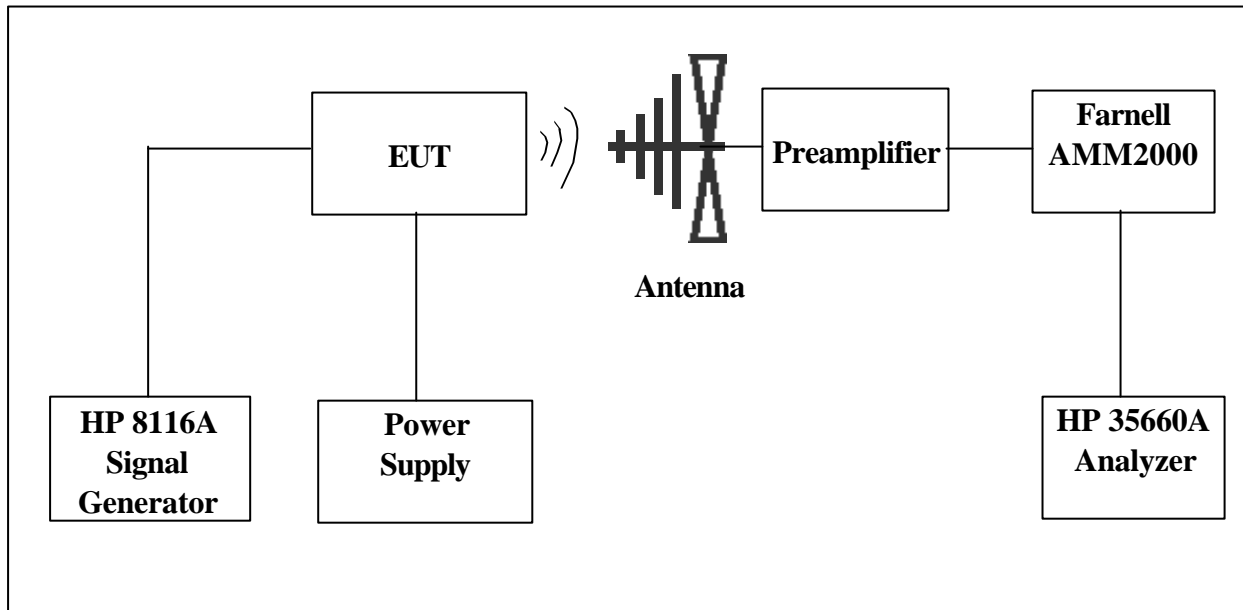

List of test instrument:

Manufacturer	Device	Model No.	Input Impedance
HP	Dynamic Signal Analyzer	HP35660A	50
HP	Signal Generator 50 MHz	HP8116A	50
SCHAFFNER	Bi-log Antenna	CBL6141A	50
Farnell	Modulation Meter	AMM2000	50
TRC	Preamplifier	TRC001	50

3.3 Frequency Response of Audio Modulation Circuit Measurement Condition & Setup

2.1047 (a)

1. The EUT and test equipment were set up as shown on the Section 4.2.
2. T The Plus/Function generator was connected to the audio input circuit/microphone of the EUT.
3. The audio signal input was adjusted to obtain 50% modulation at 1 KHz.
4. With input levels held constant and below limiting at all frequencies, the generator was varied from 100 Hz to 51.3 kHz.
5. The response in dBVrms relative to 1kHz was then measured, using the HP 35660A Dynamic Signal Analyzer as follow page.

3.4 Frequency Response of Audio Low Pass Filter Measurement Condition & Setup

1. The measurement condition and setup as Section 3.3.
2. With input levels held constant and below limiting at all frequencies, the generator was varied from 1KHz to 102.5KHz.
3. The response in dBVrms relative to 1kHz was then measured, using the HP 35660A Dynamic Signal Analyzer as follow page.

3.5 Modulation Limiting Measurement Condition & Setup

2.1047 (b)

1. The Plus/Function generator was connected to the audio input circuit/microphone of the EUT.
2. The modulation response was measured for each of four frequencies: 100Hz, 1.508KHz, 11.108KHz, 14.948KHz, 16.868KHz and 26.980KHz.
3. The input level was varied from 30% modulation to at least 20 dB higher than the saturation point.
4. Measurements were performed for both negative and positive modulation and the respective results were recorded.
5. Measurement results as Chart 3.1 to 3.2

Number: 10
Overlap: 0%

Update Rate: 5

AVERAGE IN PROGRESS

Meas

Marker X: 26.98 kHz Y: -16.611 dBm

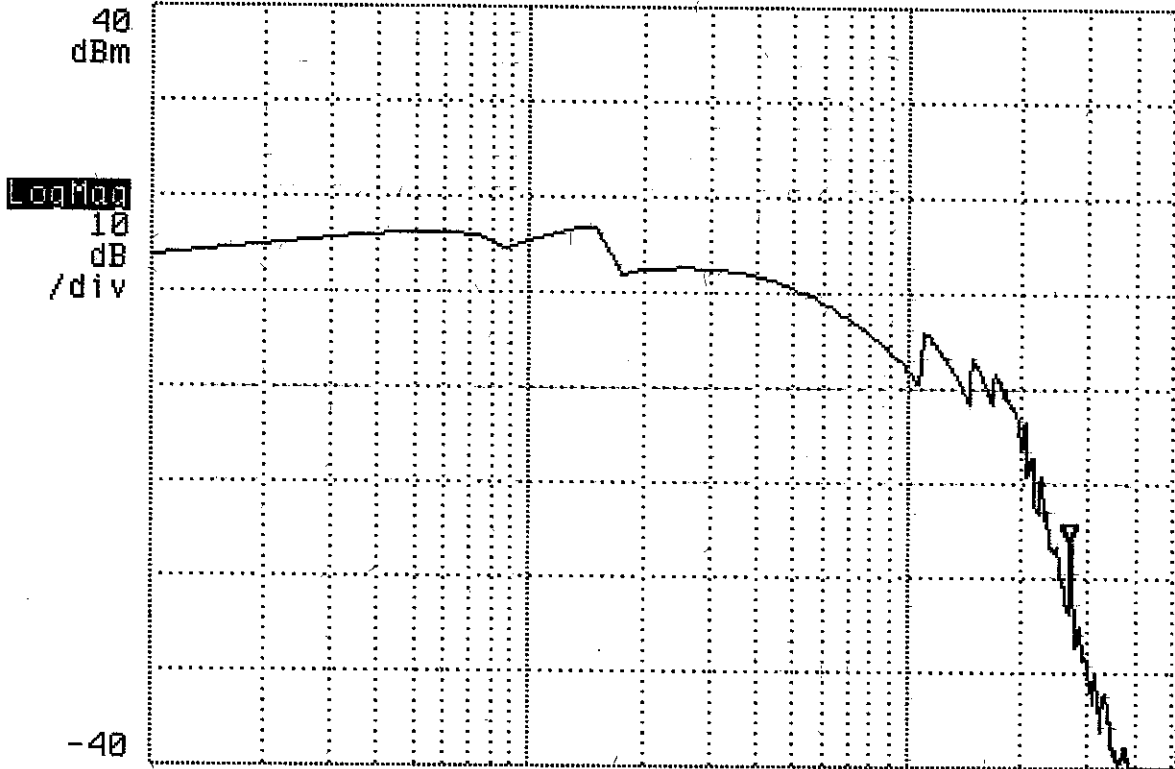

Start: 100 Hz
Spectrum Chan 1

Stop: 51.3 kHz
PEAK: 1414

Offset: OFF
X Ref: 51.2 kHz

Y Ref: -26.99 dBm

Meas

Marker X: 42.34 kHz Y: -34.261 dBm

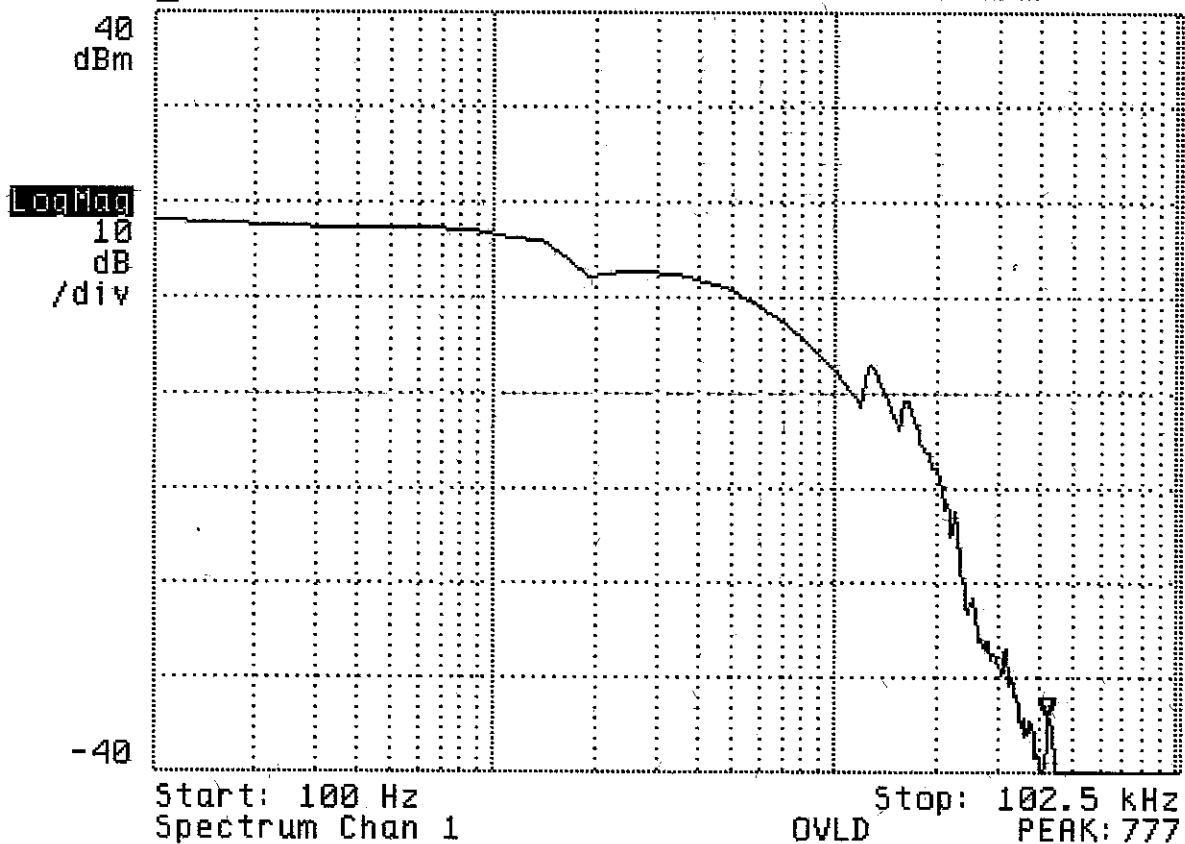

Chart 3.1 Modulation Limiting Measurement Negative

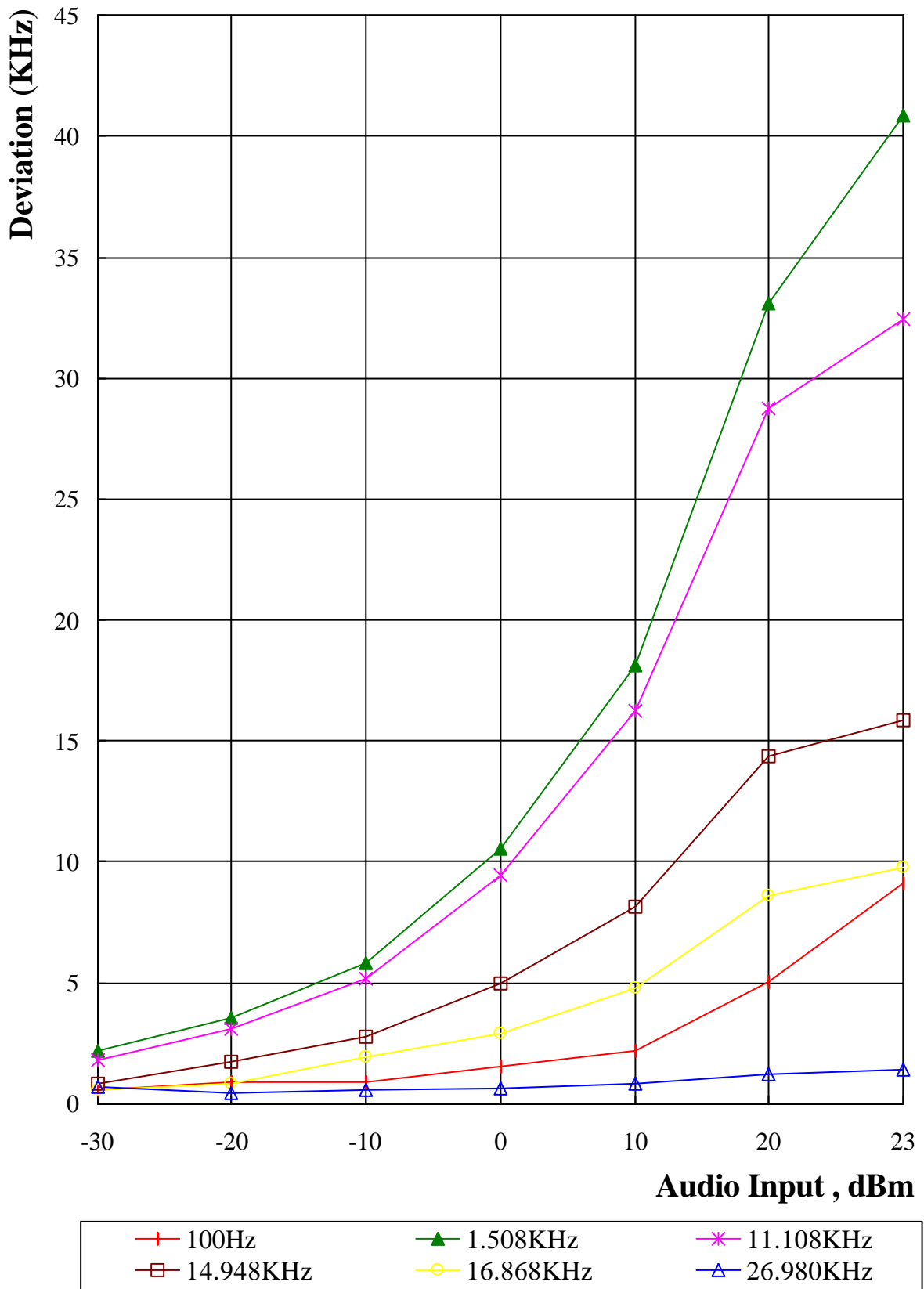
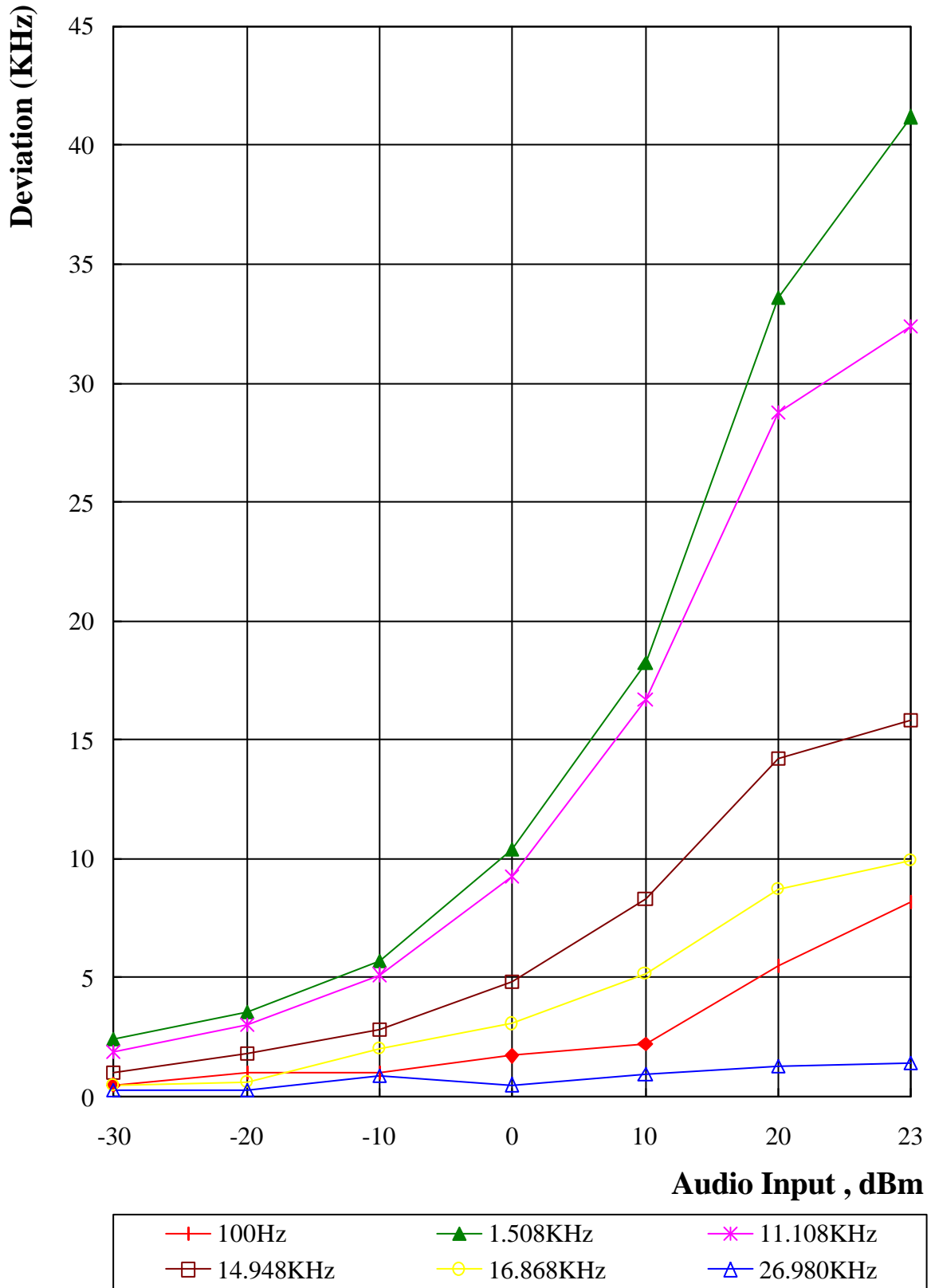

Chart 3.2 Modulation Limiting Measurement Positive



Chapter 4 Occupied Bandwidth Measurement

4.1 Rules and Specification Limits

2.1049.

74.861 (e)(3): Any form of modulation may be used. A maximum deviation of ± 75 KHz is permitted when frequency modulation is employed.

74.861 (e)(5): The operation bandwidth shall not exceed 200 KHz.

4.2 Test Configuration & List of Test Instruments

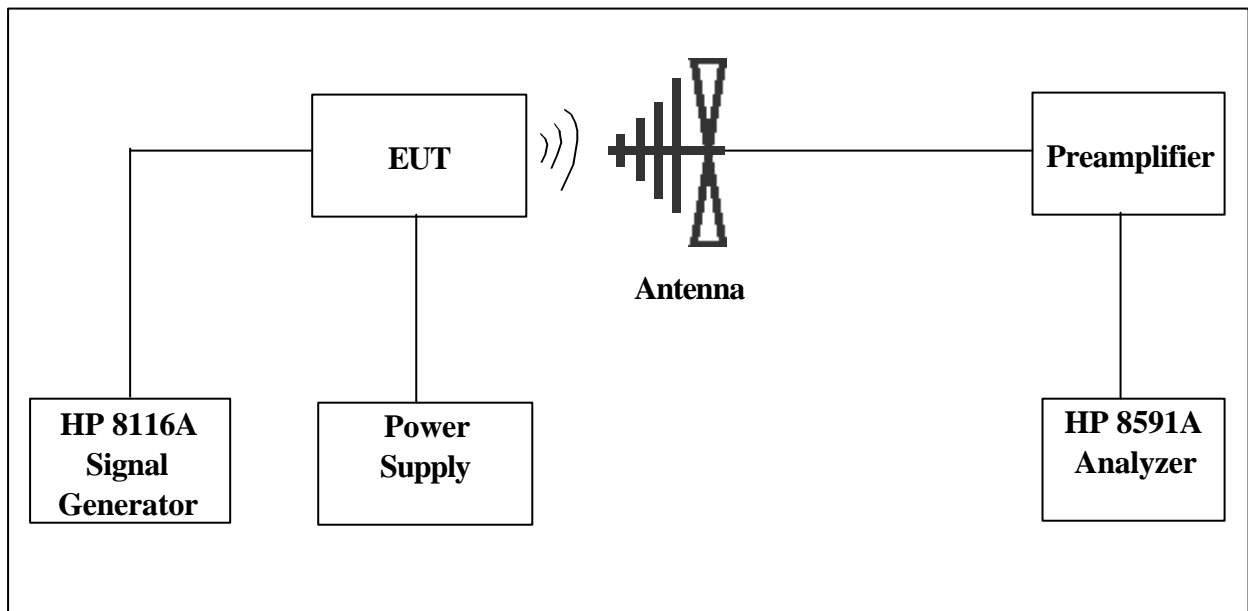

List of test Instrument :

<u>Instrument Name</u>	<u>Model No.</u>	<u>Brand</u>	<u>Input Impedance</u>
Spectrum analyzer (9K~1.8GHz)	8591A	HP	50
Pre-amplifier (30MHz~1GHz)	TRC001	TRC	50
Signal Generator 50 MHz	HP8116A	HP	50
Bi-log Antenna	CBL6141A	SCHAFFNER	50

4.3 Measurement Procedure

1. Connect the EUT as Section 4.2 .
2. Plot the unmodulated chart shows on spectrum.
3. Set the output of the signal generator to 100Hz, 1.508KHz, 11.108KHz, 14.948KHz, 16.868KHz and 26.980KHz. Increase the amplitude of the signal, while monitoring the modulation meter. Until modulation is max. Measure the bandwidth under 26 dB compared to the unmodulated fundamental carrier peak level of the modulated signal displayed on the spectrum analyzer.
4. The occupied Bandwidth was measured as follow pages.

4.4 Measurement Result

The occupied bandwidth's plot is presented on following pager, which illustrates compliance with the rules.

Calculation of Necessary Bandwidth (Bn)

$$B_n = 2M + 2D$$

$$M = \text{Max. Modulation Frequency} = 26.980\text{KHz}$$

$$D = \text{Peak Frequency Deviation} = 41.190\text{KHz} \text{ (Chart 3-1)}$$

$$K = 1$$

$$B_n = 136.340\text{KHz}$$

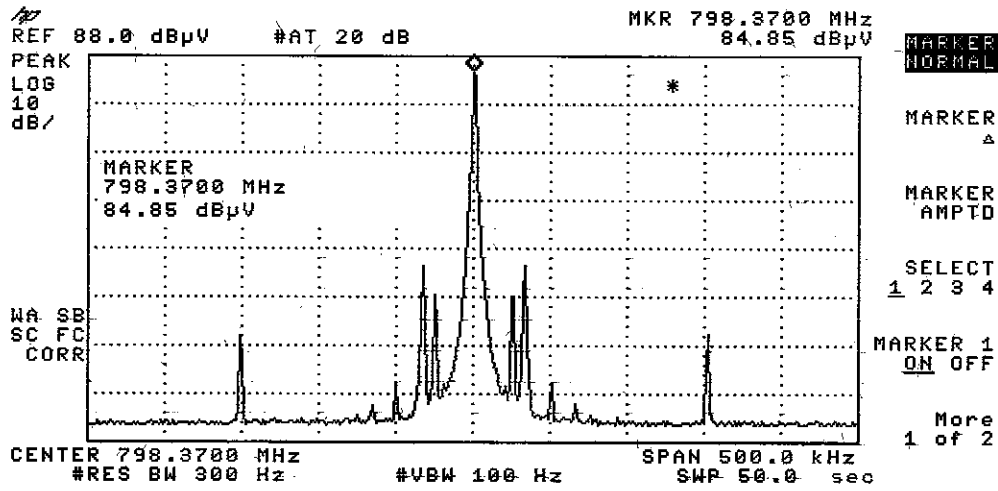

Unmodulatio

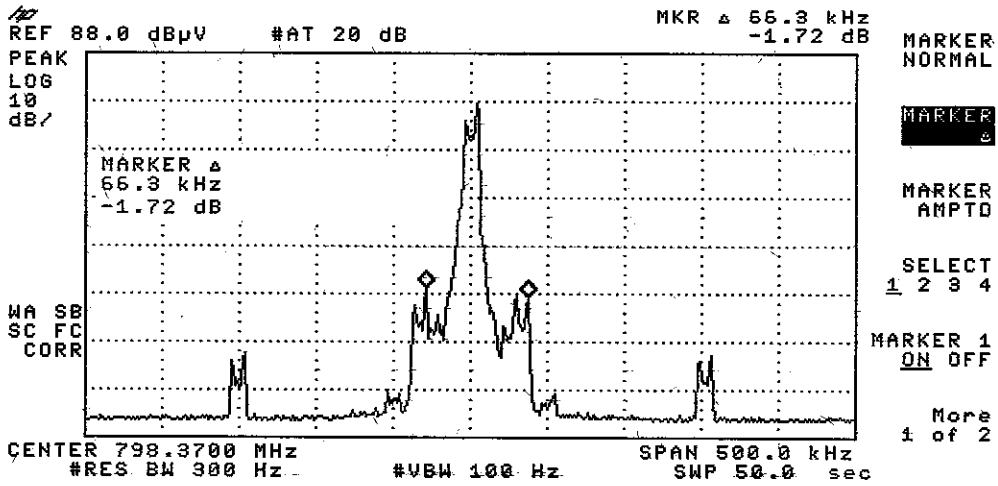

100Hz

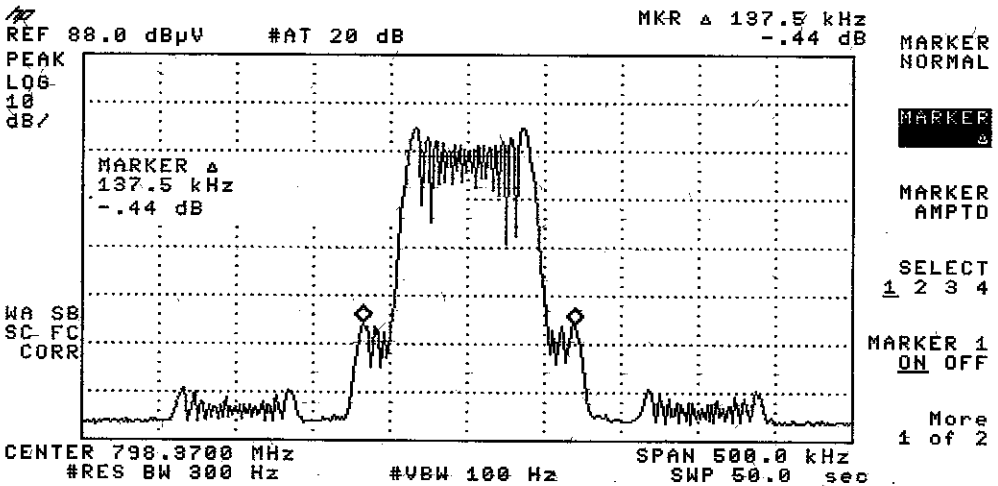

1.508KHz

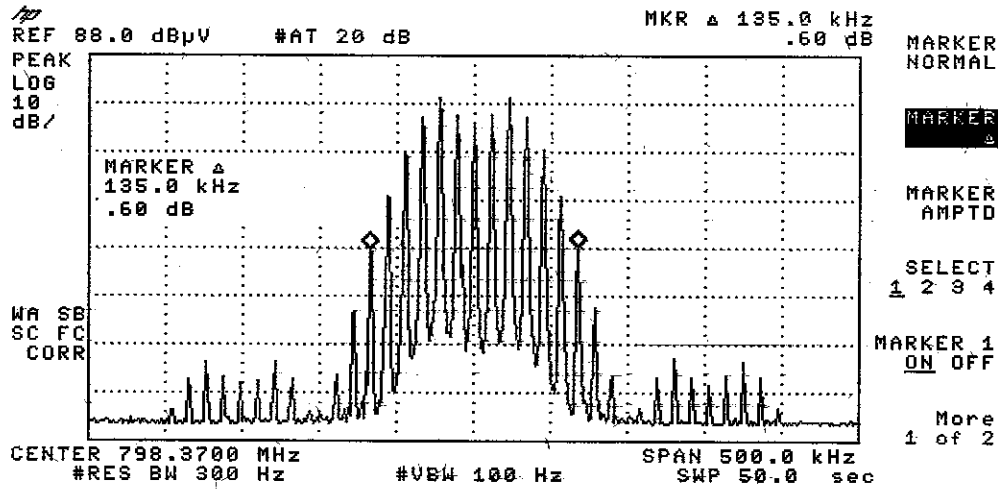

11.108KHz

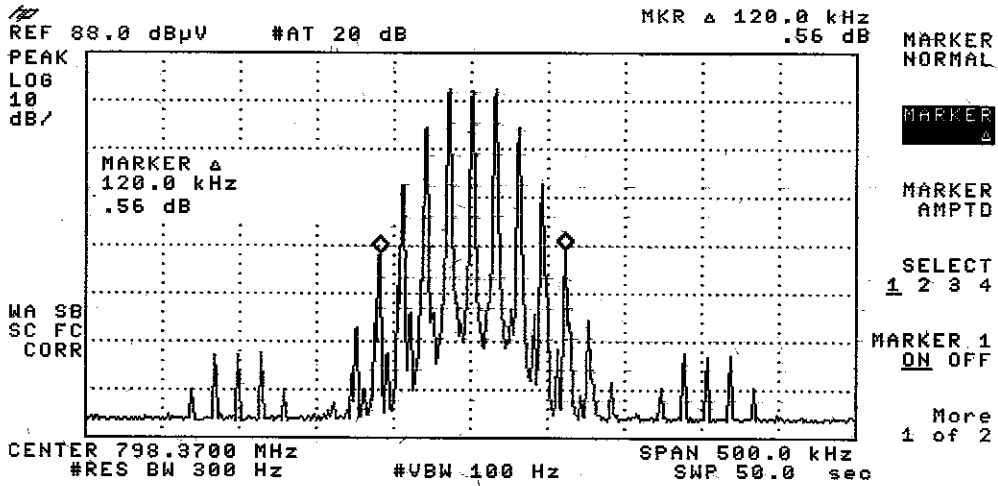

14.948KHz

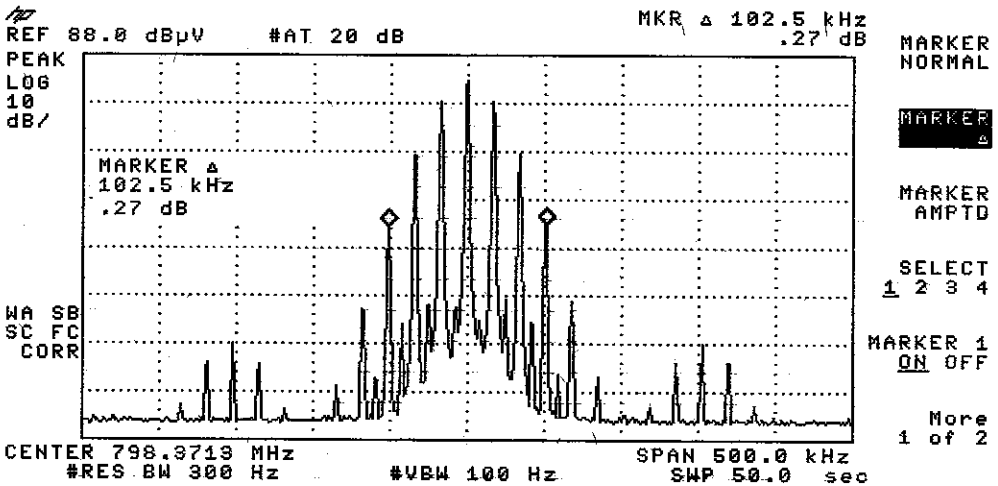

16.868KHz

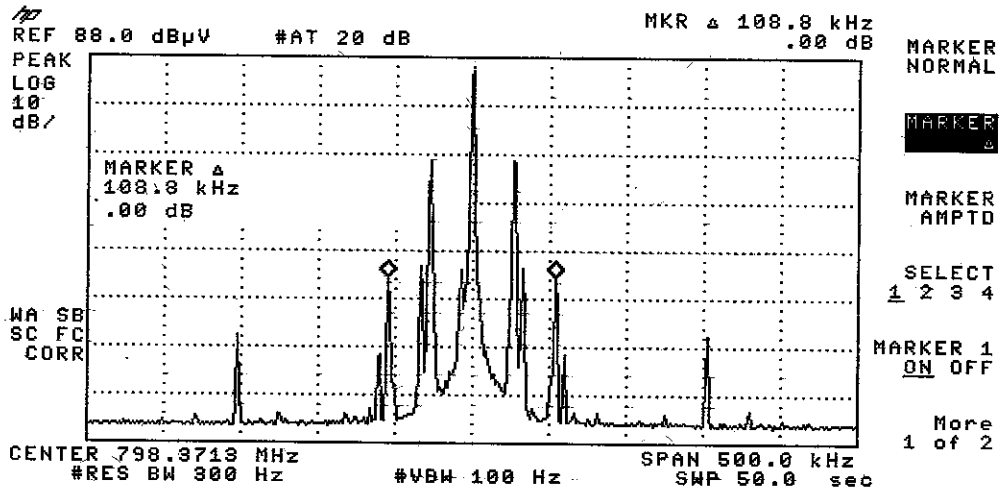

26.980KHz

Chapter 5 Field Strength of Spurious Radiation Measurement

5.1 Rules and Specification Limits

2.1053 (a) : Measurements shall be made to detect spurious emissions that may be radiated directly from the cabinet, control circuits, Power leads, or intermediate circuit elements under normal conditions of installation and operation.

74.861(e)(6)(iii) : Spurious and harmonics must be at least $43 + 10 \log (\text{Output Power})$ below the Carrier peak

2.1057 : In all measurements set forth , the spectrum should be investigated from the lowest radio frequency generated in the equipment up to at least the 10th harmonic of the carrier frequency.

5.2 Measurement Condition & Setup

Pretest : The EUT is placed in a anechoic chamber, and scan from 30MHz to 1GHz. This is done to ensure the radiation exactly emits form the EUT.

Final test : Final radiation measurements is made on a **3 - meter, anechoic chamber.** The EUT is placed on a nonconductive table, which is 0.8m height, the top surface is 1.0 x 1.5 meter. All the placement is according to ANSI C63.4 - 1992.

The spectrum is examined from 30 MHz to 18 GHz measured by HP spectrum.

The SCHAFFNER and EMCO whole range Antenna is used to measure frequency from 30 MHz to 18 GHz. The final test is used the spectrum HP 8546A, HP 85460A and 8564E.

Measure more than six top marked frequencies generated form pretest by computer step by step at each frequency. The EUT is rotated 360 degrees, and antenna is raised and lowered from 1 to 4 meter to find the maximum emission levels. The antenna is used with both horizontal and vertical polarization.

Appropriated preamplifier which is made by TRC is used for improving sensitivity and precautions is taken to avoid overloading .The spectrum analyzer's 6dB bandwidth is set to 120 K Hz , and the EUT is measured at quasi-peak mode.

If the emission is close to the frequency band of ambient, the tester will recheck the data and the corrected data will be written in the test data sheet. If the emission is just within the ambient, the data from anechoic will be taken as the final data.

The actual field intensity in decibels referenced to 1 micro volt per meter (dBµV/m) is determined by algebraically adding the measured reading in dBµV, the antenna factor (dB) and cable loss (dB) at the appropriate frequency.

(1) Band of Frequency: (30M Hz ~ 1G Hz)

$$FI_a \text{ (dB}\mu\text{V/m)} = FI_r \text{ (dB}\mu\text{V)} - \text{Corrected (dB)}$$

$$\text{Corrected (dB)} = \text{AF(dB)} + \text{CL (dB)} - \text{Amplifier Gain}$$

FI_a : Actual Field Intensity

FI_r : Reading of the Field Intensity

AF : Antenna Factor

CL : Cable Loss

(2) Band of Frequency: (1G Hz ~ 18 G Hz)

$$FI_a \text{ (dB}\mu\text{V/m)} = FI_r \text{ (dB}\mu\text{V)} + \text{AF (dB)} + \text{CL(dB)}$$

FI_a : Actual Field Intensity

FI_r : Reading of the Field Intensity

AF : Antenna Factor

CL : Cable Loss

5.3 List of Measurement Instruments

Instrument Name	Model No.	Brand	Serial No.	Calibration Date	
				Last time	Next time
EMI Receiver	8546A	H P	3520A00242	10/01/99	10/01/00
RF Filter Section	85460A	H P	3448A00217	10/01/99	10/01/00
Bi-log Antenna	CBL6141A	Schaffner	4151	06/28/00	06/28/01
Switch/Control Unit	3488A	HP	N/A	11/20/99	11/20/00
(> 30MHz)					
Auto Switch Box	ASB-01	TRC	9904-01	11/20/99	11/20/00
(> 30MHz)					
Spectrum Analyzer	8564E	HP	US36433002	08/03/99	08/03/00
Microwave Preamplifier	83051A	HP	3232A00347	08/04/99	08/04/00
Horn Antenna	3115	EMCO	9704 – 5178	08/09/99	08/09/00
Anechoic Chamber & cable calibrated together				05/20/00	05/20/01

The level of confidence of 95%, the uncertainty of measurement of radiated emission is ± 4.96 dB.

5.4 Measurement Configuration

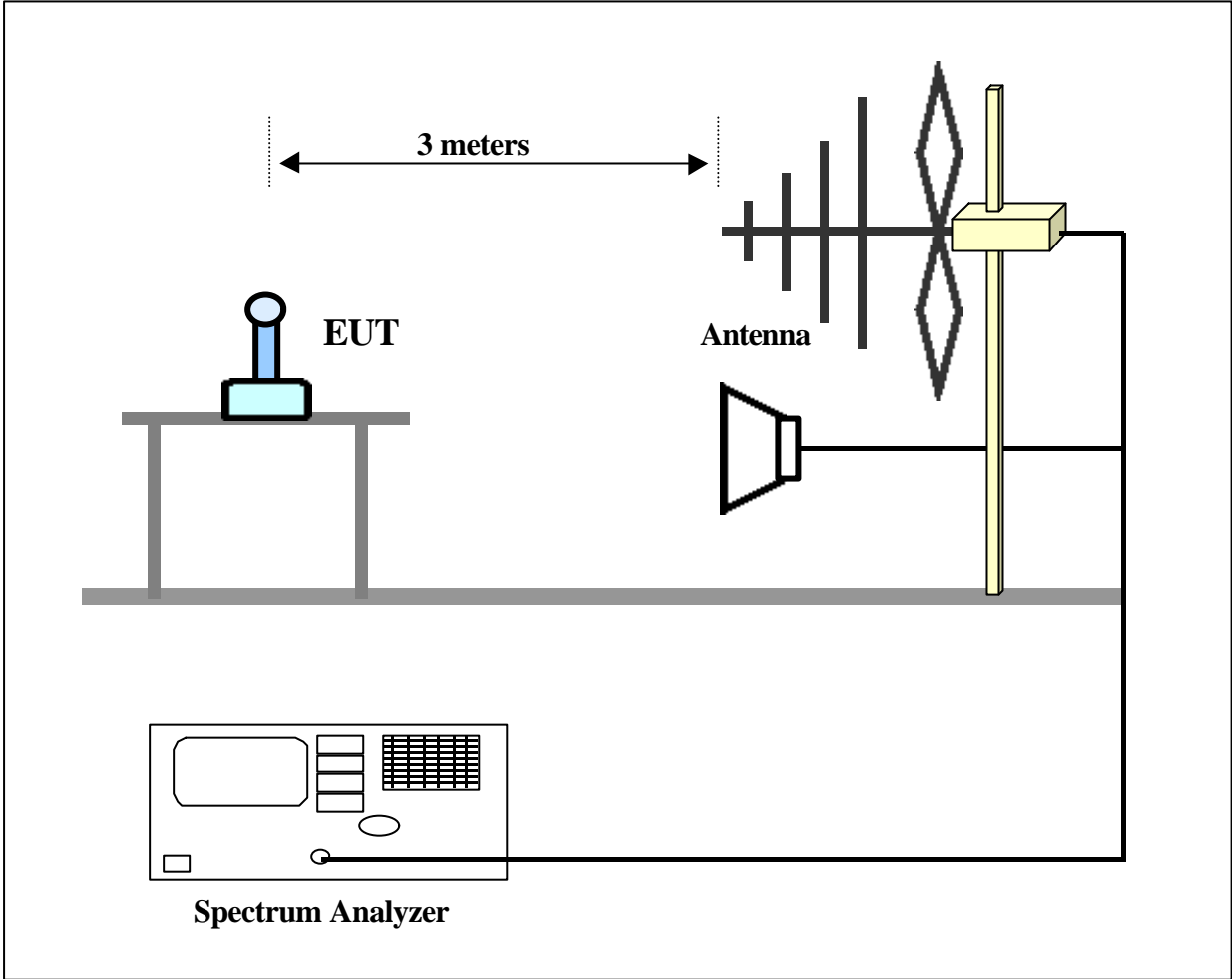



Pic 1 Front View of Test Configuration



Pic 2 Rear View of the Test Configuration

5.5 Measurement Result:

(Test Frequency: 790.375MHz , Horizontal , 30 MHz ~ 1 GHz)

Test Conditions:

Testing room : Temperature : 26 °C Humidity : 73 % RH

Testing site : Temperature : 31 °C Humidity : 75 % RH

<i>Frequency</i>	<i>Reading Amplitude</i>	<i>Ant. Height</i>	<i>Table</i>	<i>Correction Factors</i>	<i>Corrected Amplitude</i>	<i>Limit</i>	<i>Margin</i>
MHz	dBμV	m	degree	dB/m	dBμV/m	dBμV/m	dB

****The emissions of this polarity are all under the limits more than twenty dB.***

Note: Attenuation required = $43 + 10 \log (1.352936 \text{ mW}) = 14.31$

Limit = $98.69 - (14.31) = 84.38$

Measurement Result:

(Test Frequency: 790.375MHz , Horizontal , 1GHz ~ 18GHz)

Radiated Emission				Correction Factors	Corrected Amplitude (dBμV/m)	FCC Class B (3 m)	
Frequency (GHz)	Amplitude (dBμV/m)	Ant. H. (cm)	Table (°)	(dB)		Limit (dBμV/m)	Margin (dB)

1.570	58.20	1.00	42	-8.67	49.53	84.38	-34.85
2.350	65.37	1.00	116	-8.67	56.70	84.38	-27.68
3.160	63.04	1.00	97	-6.84	56.20	84.38	-28.18
3.955	71.17	1.00	304	-5.64	65.53	84.38	-18.85
4.750	53.29	1.00	182	3.91	57.20	84.38	-27.18
5.530	45.15	1.00	90	9.72	54.87	84.38	-29.51
6.325	37.98	1.00	342	9.72	47.70	84.38	-36.68
7.105	35.15	1.00	16	9.72	44.87	84.38	-39.51
7.900	35.31	1.00	297	9.72	45.03	84.38	-39.35
8.710	32.81	1.00	74	9.72	42.53	84.38	-41.85
9.490	34.81	1.00	82	9.72	44.53	84.38	-39.85

Note:

1. Margin = Corrected - Limit.
2. Peak Amplitude + Correction Factor = Corrected

Radiated Emission Test Result:

(Test Frequency: 790.375MHz , Vertical , 30MHz ~ 1GHz)

<i>Frequency</i>	<i>Reading Amplitude</i>	<i>Ant. Height</i>	<i>Table</i>	<i>Correction Factors</i>	<i>Corrected Amplitude</i>	<i>Limit</i>	<i>Margin</i>
MHz	dBμV	m	degree	dB/m	dBμV/m	dBμV/m	dB

**The emissions of this polarity are all under the limits more than twenty dB.*

Radiated Emission Test Result:

(Test Frequency: 790.375MHz , Vertical , 1GHz ~ 18GHz)

Radiated Emission				Correction Factors	Corrected Amplitude (dBμV/m)	FCC Class B (3 m)	
Frequency (GHz)	Amplitude (dBμV/m)	Ant. H. (cm)	Table (°)	(dB)		Limit (dBμV/m)	Margin (dB)

1.570	51.04	1.00	57	-8.67	42.37	84.38	-42.01
2.350	77.54	1.00	116	-8.67	68.87	84.38	-15.51
3.160	56.71	1.00	69	-6.84	49.87	84.38	-34.51
3.955	75.51	1.00	189	-5.64	69.87	84.38	-14.51
4.750	51.29	1.00	101	3.91	55.20	84.38	-29.18
5.530	60.81	1.00	257	9.72	70.53	84.38	-13.85
6.325	49.15	1.00	110	9.72	58.87	84.38	-25.51
7.105	60.81	1.00	120	9.72	70.53	84.38	-13.85
7.900	50.81	1.00	85	9.72	60.53	84.38	-23.85
8.710	58.81	1.00	331	9.72	68.53	84.38	-15.85
9.490	52.48	1.00	8	9.72	62.20	84.38	-22.18

Measurement Result:

(Test Frequency: 798.375MHz , Horizontal , 1GHz ~ 18GHz)

Radiated Emission				Correction Factors	Corrected Amplitude (dBμV/m)	FCC Class B (3 m)	
Frequency (GHz)	Amplitude (dBμV/m)	Ant. H. (cm)	Table (°)	(dB)		Limit (dBμV/m)	Margin (dB)

1.585	58.37	1.00	87	-8.67	49.70	84.38	-34.68
2.380	70.20	1.00	352	-8.67	61.53	84.38	-22.85
3.190	62.87	1.00	258	-6.84	56.03	84.38	-28.35
4.000	71.17	1.00	107	-5.64	65.53	84.38	-18.85
4.795	52.62	1.00	225	3.91	56.53	84.38	-27.85
5.590	45.15	1.00	4	9.72	54.87	84.38	-29.51
6.385	40.98	1.00	98	9.72	50.70	84.38	-33.68
7.180	36.31	1.00	169	9.72	46.03	84.38	-38.35
7.990	37.15	1.00	228	9.72	46.87	84.38	-37.51
8.785	36.31	1.00	86	9.72	46.03	84.38	-38.35
9.580	33.48	1.00	147	9.72	43.20	84.38	-41.18

Radiated Emission Test Result:

(Test Frequency: 798.375MHz , Vertical , 30MHz ~ 1GHz)

<i>Frequency</i>	<i>Reading Amplitude</i>	<i>Ant. Height</i>	<i>Table</i>	<i>Correction Factors</i>	<i>Corrected Amplitude</i>	<i>Limit</i>	<i>Margin</i>
MHz	dBμV	m	degree	dB/m	dBμV/m	dBμV/m	dB

**The emissions of this polarity are all under the limits more than twenty dB.*

Radiated Emission Test Result:

(Test Frequency: 798.375MHz , Vertical , 1GHz ~ 18GHz)

<i>Radiated Emission</i>				<i>Correction Factors</i>	<i>Corrected Amplitude</i> (dBμV/m)	<i>FCC Class B (3 m)</i>	
<i>Frequency</i> (GHz)	<i>Amplitude</i> (dBμV/m)	<i>Ant. H.</i> (cm)	<i>Table</i> (°)	(dB)		<i>Limit</i> (dBμV/m)	<i>Margin</i> (dB)

1.585	51.20	1.00	225	-8.67	42.53	84.38	-41.85
2.380	78.04	1.00	107	-8.67	69.37	84.38	-15.01
3.190	56.71	1.00	69	-6.84	49.87	84.38	-34.51
4.000	75.51	1.00	215	-5.64	69.87	84.38	-14.51
4.795	51.46	1.00	334	3.91	55.37	84.38	-29.01
5.590	60.98	1.00	192	9.72	70.70	84.38	-13.68
6.385	49.31	1.00	324	9.72	59.03	84.38	-25.35
7.180	61.98	1.00	80	9.72	71.70	84.38	-12.68
7.990	50.98	1.00	58	9.72	60.70	84.38	-23.68
8.785	58.98	1.00	261	9.72	68.70	84.38	-15.68
9.580	51.45	1.00	92	9.72	61.17	84.38	-23.21

Measurement Result:

(Test Frequency: 805.375MHz , Horizontal , 30MHz ~ 1GHz)

<i>Frequency</i>	<i>Reading Amplitude</i>	<i>Ant. Height</i>	<i>Table</i>	<i>Correction Factors</i>	<i>Corrected Amplitude</i>	<i>Limit</i>	<i>Margin</i>
MHz	dBμV	m	degree	dB/m	dBμV/m	dBμV/m	dB

****The emissions of this polarity are all under the limits more than twenty dB.***

Note: Attenuation required = $43 + 10 \log (1.055061 \text{ mW}) = 24.69$

Limit = $97.61 - (13.23) = 84.38$

Measurement Result:

(Test Frequency: 805.375MHz , Horizontal , 1GHz ~ 18GHz)

Radiated Emission				Correction Factors	Corrected Amplitude (dBμV/m)	FCC Class B (3 m)	
Frequency (GHz)	Amplitude (dBμV/m)	Ant. H. (cm)	Table (°)	(dB)		Limit (dBμV/m)	Margin (dB)

1.600	58.37	1.00	337	-8.67	49.70	84.38	-34.68
2.410	66.20	1.00	208	-8.67	57.53	84.38	-26.85
3.220	62.54	1.00	46	-6.84	55.70	84.38	-28.68
4.030	68.84	1.00	52	-5.64	63.20	84.38	-21.18
4.840	51.29	1.00	196	3.91	55.20	84.38	-29.18
5.635	44.81	1.00	208	9.72	54.53	84.38	-29.85
6.445	39.65	1.00	24	9.72	49.37	84.38	-35.01
7.255	37.31	1.00	259	9.72	47.03	84.38	-37.35
8.065	34.48	1.00	167	9.72	44.20	84.38	-40.18
8.860	33.93	1.00	182	9.72	43.65	84.38	-40.73
9.655	33.15	1.00	90	9.72	42.87	84.38	-41.51

Radiated Emission Test Result:

(Test Frequency: 805.375MHz , Vertical , 30MHz ~ 1GHz)

<i>Frequency</i>	<i>Reading Amplitude</i>	<i>Ant. Height</i>	<i>Table</i>	<i>Correction Factors</i>	<i>Corrected Amplitude</i>	<i>Limit</i>	<i>Margin</i>
MHz	dBμV	m	degree	dB/m	dBμV/m	dBμV/m	dB

**The emissions of this polarity are all under the limits more than twenty dB.*

Radiated Emission Test Result:

(Test Frequency: 805.375MHz , Vertical , 1GHz ~ 18GHz)

Radiated Emission				Correction Factors	Corrected Amplitude (dBμV/m)	FCC Class B (3 m)	
Frequency (GHz)	Amplitude (dBμV/m)	Ant. H. (cm)	Table (°)	(dB)		Limit (dBμV/m)	Margin (dB)

1.600	49.87	1.00	82	-8.67	41.20	84.38	-43.18
2.410	78.04	1.00	109	-8.67	69.37	84.38	-15.01
3.220	55.37	1.00	156	-6.84	48.53	84.38	-35.85
4.030	75.01	1.00	207	-5.64	69.37	84.38	-15.01
4.840	50.29	1.00	32	3.91	54.20	84.38	-30.18
5.635	60.81	1.00	57	9.72	70.53	84.38	-13.85
6.445	49.15	1.00	106	9.72	58.87	84.38	-25.51
7.255	62.48	1.00	207	9.72	72.20	84.38	-12.18
8.065	51.15	1.00	331	9.72	60.87	84.38	-23.51
8.860	58.98	1.00	94	9.72	68.70	84.38	-15.68
9.655	49.81	1.00	5	9.72	59.53	84.38	-24.85

Chapter 6 Frequency Stability Tolerance Measurement

6.1 Rules and Specification Limits

2.1055

74.861(e)(4): The frequency tolerance of the transmitter shall be 0.005 percent.

6.2 Measurement Condition & Setup with Temperature Variation

1. Place the EUT in the chamber, powered in its normal operation.
2. Set the temperature of the chamber -30 degree Centigrade. Allow the equipment to stabilize at that temperature.
3. Measured the carrier frequency using preamplifier and frequency counter.
4. Repeated procedures 1 to 3 from -20 to 50 degree Centigrade at intervals of 10 degree.

6.3 List of Measurement Instruments with Temperature Variation List of test Instrument :

<u>Instrument Name</u>	<u>Model No.</u>	<u>Brand</u>	<u>Remark</u>
Spectrum Analyzer	8591A	H P	1.8GHz
Temperature Chamber	THS-MV2	King Son	
Near field Probe	7405-901	EMCO	
Power Supply	GPR-6030	Good Will	
Auto Transformer	Powerstat	Supprior Elec. Co.	

6.4 Measurement Configuration of Temperature Variation Test:

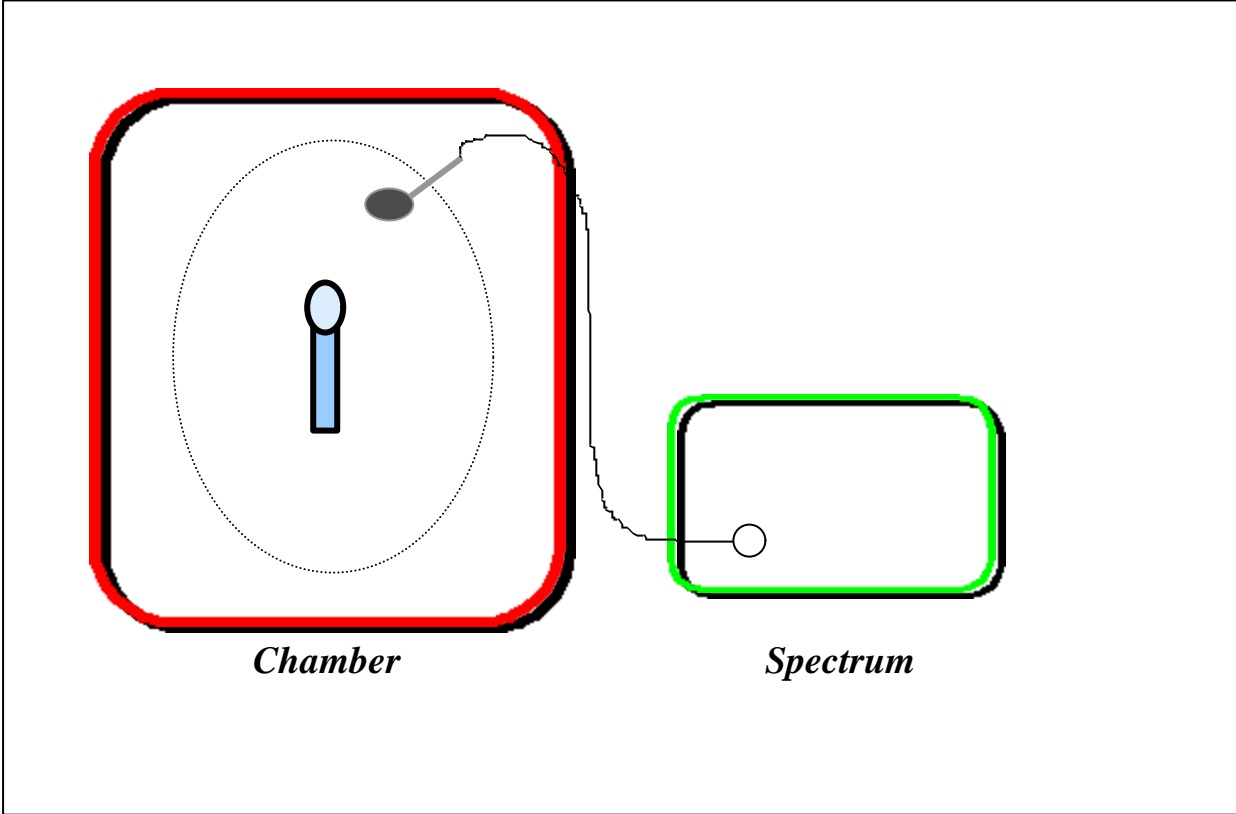

6.5 Measurement Result with Temperature Variation

A plot and table is presented which illustrates compliance with the rule where the center frequency is 798.375MHz.

Temperature Variation Table

<i>Temperature (Centigrade)</i>	<i>Frequency (MHz)</i>	<i>Tolerance (MHz)</i>
-30	798.3594012	798.3350813 ~ 798.4149188
-20	798.3648568	798.3350813 ~ 798.4149188
-10	798.3682175	798.3350813 ~ 798.4149188
0	798.3700601	798.3350813 ~ 798.4149188
10	798.3707713	798.3350813 ~ 798.4149188
20	798.3711243	798.3350813 ~ 798.4149188
30	798.3711669	798.3350813 ~ 798.4149188
40	798.3712507	798.3350813 ~ 798.4149188
50	798.3717815	798.3350813 ~ 798.4149188

Temperatuer Variation Vs. Frequency Chart

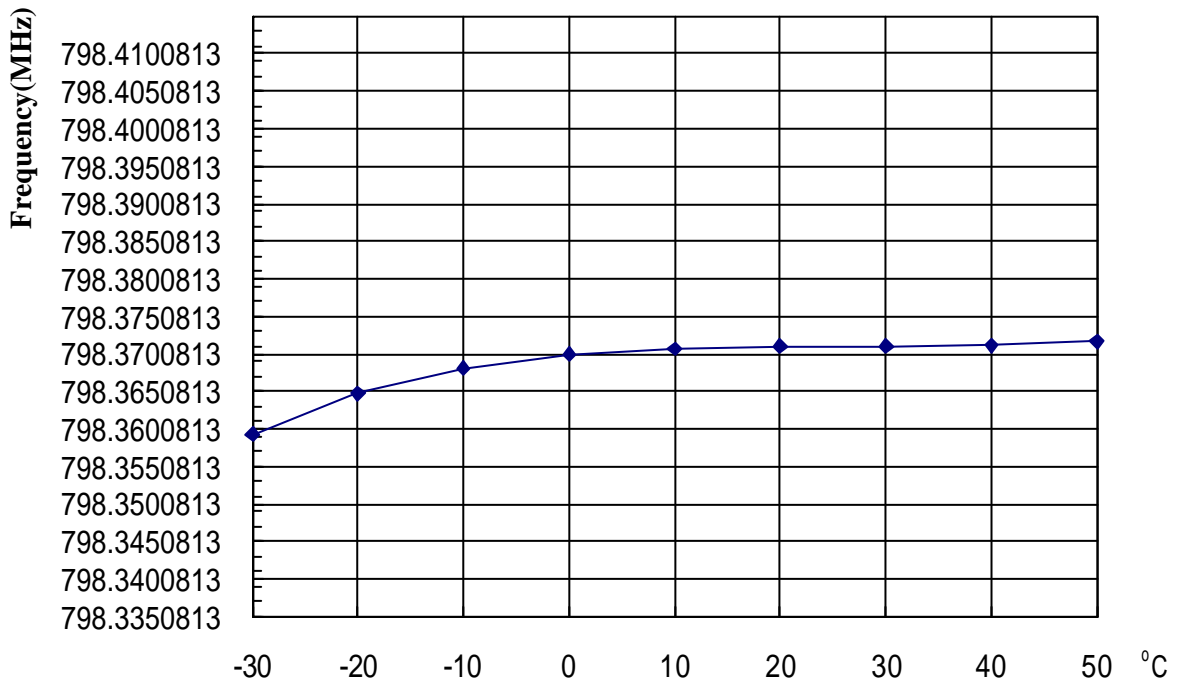

6.6 Measurement Condition & Setup with Voltage Variation

1. Attached the power line of the power supply to the battery position of the EUT.
2. Tuned the output power level to battery end point, 85 %, 100%, 115% of the normal operation power of EUT.
3. Recorded the frequency with a frequency counter.

6.7 List of Test Instrument :

<u>Instrument Name</u>	<u>Model No.</u>	<u>Brand</u>	<u>Remark</u>
Spectrum Analyzer	8591A	H P	1.8GHz
Temperature Chamber	THS-MV2	King Son	
Near field Probe	7405-901	EMCO	
Power Supply	GPR-6030	Good Will	
Auto Transformer	Powerstat	Supprior Elec. Co.	

6.8 Configuration of Voltage Variation Test :

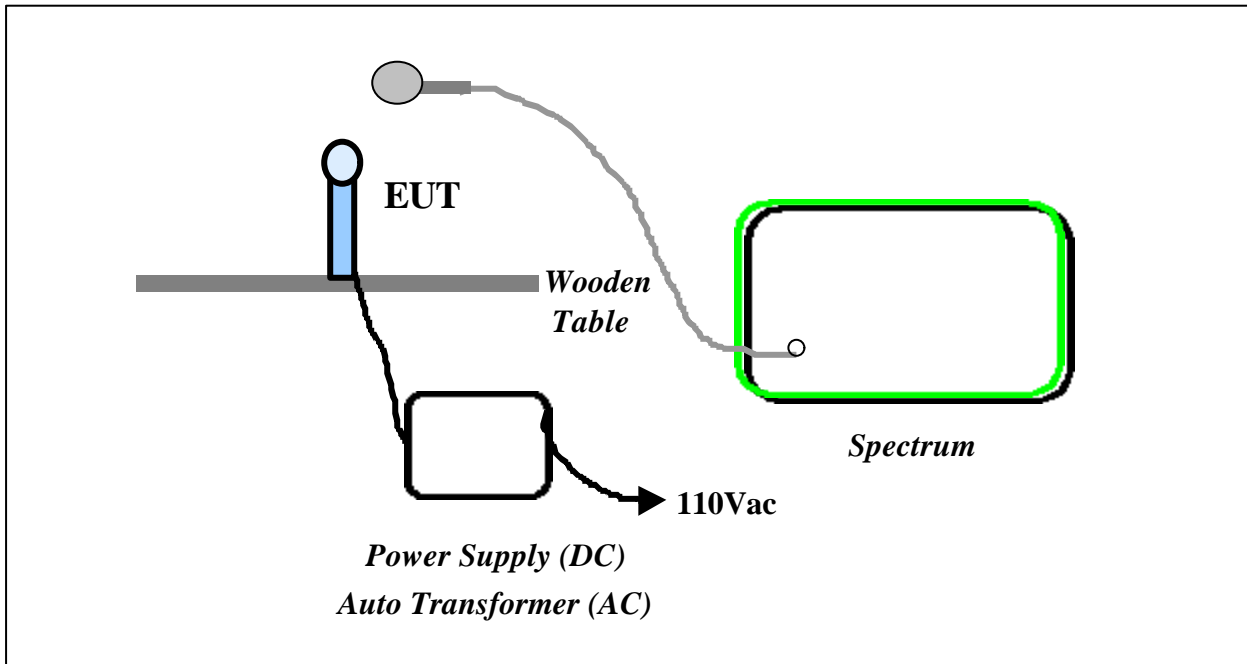

6.9 Measurement Result with Voltage Variation

Frequency Stability of Voltage Variation Measurement Table

<i>Supply Voltage (Volt)</i>	<i>Frequency (MHz)</i>	<i>Tolerance (MHz)</i>
2.55 (85%)	798.3712307	798.3350813 ~ 798.4149188
3 (100%)	798.3712435	798.3350813 ~ 798.4149188
3.45 (115%)	798.3712389	798.3350813 ~ 798.4149188
Endpoint-Voltage: 1.56V		

Voltage Variation Vs. Frequency Chart

