

USER'S MANUAL

UHF BAND

WIRELESS MICROPHONE SYSTEM

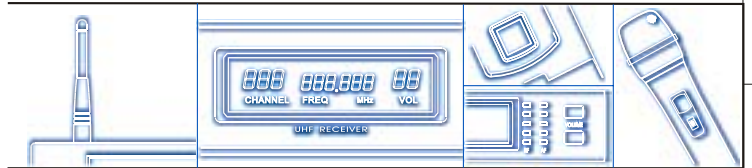

WIRELESS MICROPHONE SYSTEM

<u>Table of Contents</u>	<u>Page</u>
1. Introduction	1
2. Safety	1
3. Environment	1
4. Wireless Note	1
5. Product Description	2
5.1 Receiver	
5.1.1 True-diversity type	
5.1.2 Switching-diversity type	
5.2 Handheld Microphone	
5.3 Bodypack Transmitter	
6. Basic Connections	8
7. Setting Up	10
7.1 Connecting the receiver to power	
7.2 Connecting the receiver to an audio mixer or an amplifier	
7.3 Inserting batteries into the handheld / bodypack transmitter	
7.4 Setting up the handheld transmitter	
7.5 Setting up the bodypack transmitter	
8. Trouble-shooting	11
9. System Feature	12
10. System Specification	12

WIRELESS NOTE

FCC Statement

This device complies with part 15 of the FCC rules. Operation is subject to the following two conditions: (1) This device may not cause harmful interference and (2) This device must accept any interference received, including interference that may cause undesired operation.

Notice : The changes or modifications not expressly approved by the party responsible for compliance could void the user's authority to operate the equipment.

IMPORTANT NOTE: To comply with the FCC RF exposure compliance requirements, no change to the antenna or the device is permitted. Any change to the antenna or the device could result in the device exceeding the RF exposure requirements and void user's authority to operate the device.

1. Introduction

Thank you for purchasing our product. This wireless microphone system operates in UHF band frequency with synthesizer controlled. The system with 700 selectable frequencies via Phase Locked Loop (PLL) circuitry makes it easy to choose non-interfered channels. Please read this instruction manual carefully before operating the system. This manual covers the function and operation of the wireless microphone system.

2. Safety

- Do not spill liquid on the appliance and do not drop it on a hard concrete floor.
- Do not place the appliance near heat sources such as radiators, amplifier, or etc.
- Do not expose it to direct sunlight, extremely dust, excessive moisture, or vibration.
- Take out the battery from transmitter, if the appliance has been not used for a longer period. This will avoid the damage resulting from a defective leaking battery.

3. Environment

- Do not throw used batteries into a fire or garbage bin with domestic rubbish. Be sure to dispose of used batteries in accordance with local waste disposal rules.
- When disposing the equipment, remove the batteries, separate the case, circuit boards, and cables, and dispose of all components in accordance with local waste disposal rules.

4. Wireless Note

- Before setting up, make sure that the transmitter and receiver are tuned to the same frequency.
- Do not use two transmitters in the same frequency.
- When two or above transmitters are operated simultaneously, please arrange at least with 10-channel spaces between each channels.
- Use good quality batteries to avoid the damage resulting from a defective leaking battery.
- Push the volume button on the receiver to adjust receiver output level to match input level requirements of an audio mixer or an amplifier.
- To avoid interference, do not put the receiver too near metal object and avoid obstructions between transmitter and receiver.
- Avoid the interference from TV, radio, other wireless appliances and etc.

PRODUCT DESCRIPTION

5. Product Description**5.1 Receivers**

The receivers are used with our 700 selectable channels transmitters. The receiver operates in UHF band frequency with PLL synthesized control. Powered by 12V DC.

5.1.1 True-diversity type

Single channel, 1/2 rack

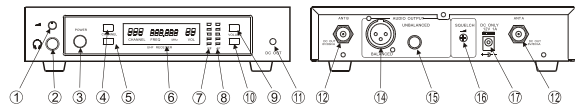

Single channel, full rack

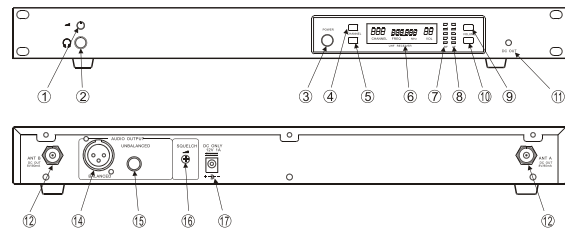

Dual channel, full rack

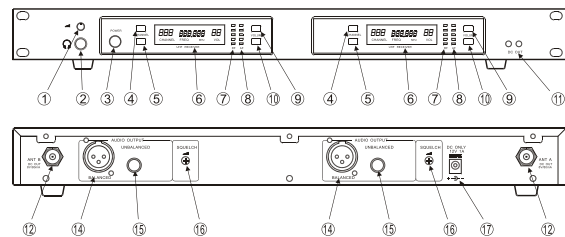

PRODUCT DESCRIPTION

5.1.2 Switching-diversity type

Single channel, 1/2 rack, fixed antennas

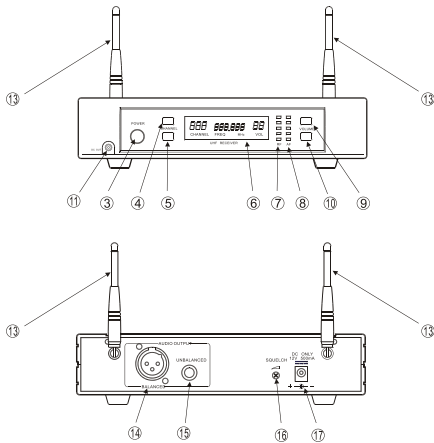

Single channel, 1/2 rack, detachable antennas

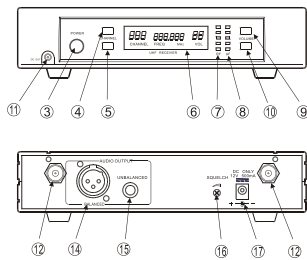

PRODUCT DESCRIPTION

1. **Headphone Monitor Volume Control:** Rotate this knob to control headphone volume level.
2. **Headphone Input Connector:** Plug headphone into this 6.3φ connector to monitor receiver audio.
3. **Power:** Pushes the receiver on and off.
4. **Channel + Button:** Press this button to change channel forward.
5. **Channel - Button:** Press this button to change channel backward.
6. **Programmable Display:** Displays channel number, frequency and volume level.
7. **RF Level Indicators:** Five LEDs per RF antenna channel glow to indicate RF signal strength. The more LEDs that glow, the stronger the received signal. If none of these LEDs glow, no signal is being received.
8. **AF Level Indicators:** Five LEDs glow to indicate audio signal strength. Green indicates normal operation. RED indicates approaching overload condition.
9. **Volume + Button:** Press this button to increase the receiver output level to match the input sensitivity of an audio mixer or an amplifier.
10. **Volume - Button:** Press this button to decrease the receiver output level to match the input sensitivity of an audio mixer or an amplifier.
11. **DC Out:** Connect the supplied cable to the receiver and the microphone, and it takes around 10 hours to charge.
12. **Antenna Input Connector:** TNC-type connectors provide connection to the supplied antennas or to coaxial cable used with an antenna divider, antenna boosters or remote antennas.
13. **Antenna:** Fixed-length UHF antenna permanently mounted on rear panel.
14. **Balanced Output:** 3-pin XLR connector provides balanced low-impedance output
15. **Unbalanced Output:** 6.3 φphone jack provides unbalanced low-impedance output
16. **Squelch:** The squelch adjusts the output level to suppress the noise. The higher squelch control, the lower the sensitivity of the receiver and decrease the service area of the system. Set the squelch to minimum before turning the receiver on.
17. **DC IN:** Input connector for the supplied AC adapter.

PRODUCT DESCRIPTION

To combine two receivers in a 19" standard rack by using 2 short L type plastic racks (L2) and 2 metal connecting plates (C1). (Each system includes a L2 and a C1.)

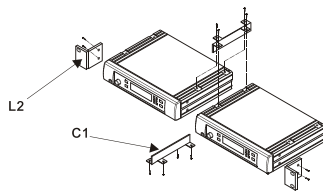

To mount a receiver in a 19" standard rack by using 2 long L type metal racks (L1). (L1 is an optional product, so please purchase extra in local shops.)

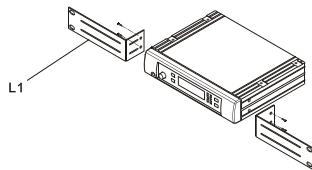

Charging Connecting Diagram

Connect the supplied DC cable to the receiver and the microphone, and it takes around 10 hours to charge and the LED of transmitter is flashing all the time.

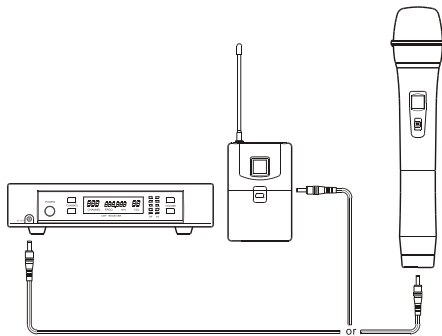

PRODUCT DESCRIPTION

5.2 Handheld Microphone

The handheld microphone operates in UHF band frequency with PLL synthesized control. UHF 700 preprogrammed selectable frequencies to avoid interference. Uni-directional dynamic or uni-directional electret condenser cartridges feature different characters for various choices. Use DC1.5V x 2 AA size dry or rechargeable batteries for cost-saving and environmental protection.

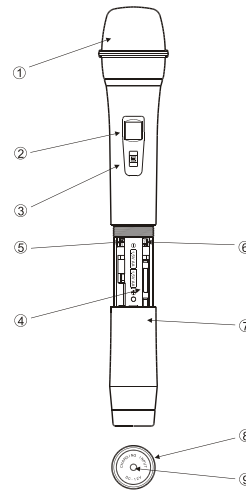

1. **Grille:** Protects the microphone capsule and helps reduce breath sounds and wind noise.
2. **Programmable Display:** Displays channel number and battery power level
3. **On/off Switch:** Turns transmitter power on and off.
4. **Battery Compartment:** Insert DC1.5V x 2 AA dry or rechargeable batteries into the compartment and make sure that the polarity of batteries is correct.
5. **Channel + Button:** Press this button to change channel forward.
6. **Channel - Button:** Press this button to change channel backward.
7. **Battery Cover:** Unscrew to expose battery compartment and channel buttons.
8. **Color Clip:** This color clip helps to identify the frequency for multi-channel operation.
9. **Charging Input:** The inserted rechargeable batteries are charged by using the supplied DC-plug cable connection to DC Out on the receiver. It takes up to 10 hours for charging.

PRODUCT DESCRIPTION

5.3 Bodypack Transmitter

The bodypack transmitter operates in UHF band frequency with PLL synthesized control. UHF 700 preprogrammed selectable frequencies to avoid interference. Various uni-directional electret condenser cartridge options. Use DC1.5V x 2 AA size dry or rechargeable batteries for low operating cost.

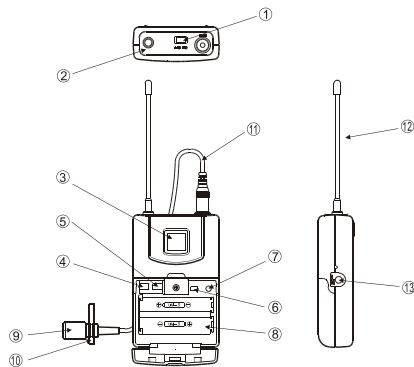

1. **On/Off Switch:** Turns transmitter power on and off.
2. **3-pin Mini XLR Connector:** The included electret laval microphone is inserted into the connector on transmitter.
3. **Programmable Display:** Displays channel number and battery power level
4. **Channel + Button:** Press this button to change channel forward.
5. **Channel - Button:** Press this button to change channel backward.
6. **Mic/Line Selector:** The switch sets the audio input either to microphone level or line level.
7. **Gain.:** The rotary control adjusts the sensitivity of the transmitter's audio to the level of the connected laval microphone or instrument.
8. **Battery Compartment:** Insert DC1.5V x 2 AA dry or rechargeable batteries into the compartment and make sure that the polarity of batteries is correct.
9. **Mic Unit:** The uni-directional electret condenser unit features the wide frequency response for warm, rich bass and clear sound.
10. **Tie Clip:** To clip on the tie or lapel for free-movement.
11. **Cable:** With 3-pin mini XLR connector cable to connect the transmitter.
12. **Antenna:** Permanently connected, helical antenna.
13. **Charging Input:** The inserted rechargeable batteries are charged by using the supplied DC-plug cable connection to DC Out on the receiver. It takes up to 10 hours for charging.

BASIC CONNECTIONS

6. Basic Connections

Connect the receiver output to the audio mixer or amplifier input, using a standard audio cable with 3-pin XLR connectors or 6.3φ phone plugs. Never use the balanced and unbalanced audio outputs at the same time! This may cause signal loss or increased noise.

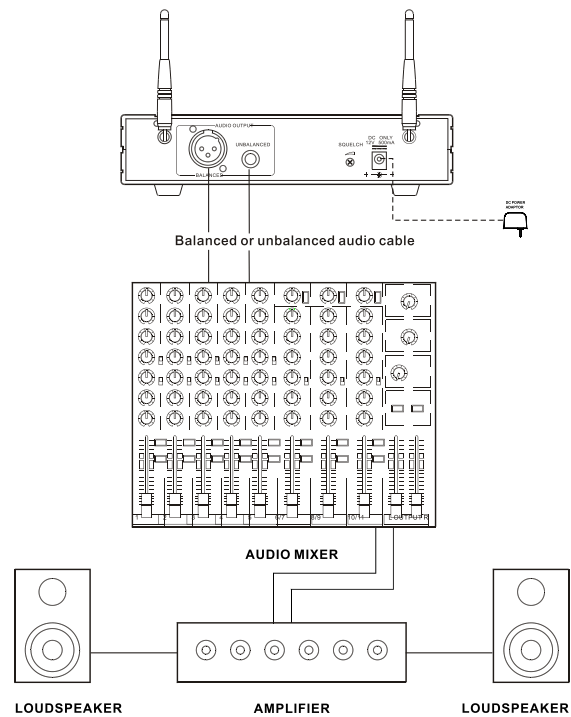

BASIC CONNECTIONS

AB-8A, the antenna booster is highly recommended for long-distance purpose, such as in stadium or in auditorium. By means of antenna holder, the antenna and booster can put wherever you want. It is ideal design for multi-channel application. Antenna boosters are applied to the receivers, which have detachable antennas.

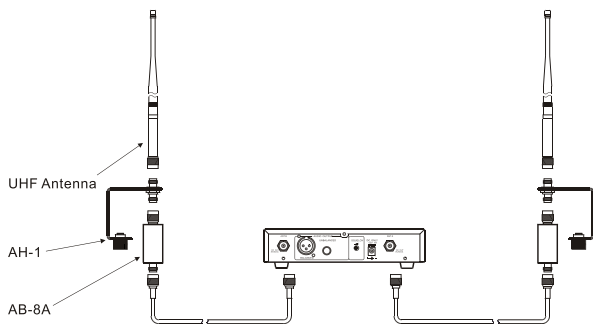

Antenna holder makes it easy to fix wherever for connection antenna and booster. AH-1 can be assembled on the mic stand or on the wall.

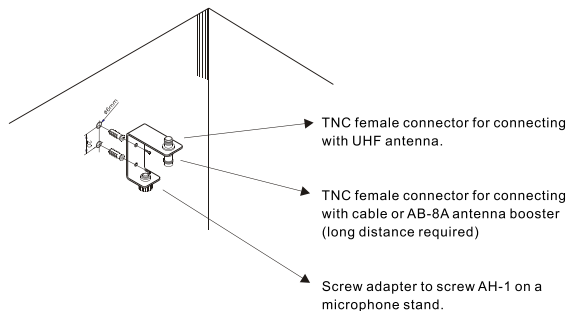

SETTING UP

7. Setting Up

NOTICE: Prior to setting up, check that the transmitter and receiver are tuned to the same frequency. Two or above transmitters operating in the same frequency can not be used at the same time and area, so please arrange at least with 10-channel spaces between each channels.

7.1 Connecting the receiver to power

- Plug the antennas into the TNC socket on the receiver, if the antennas are detachable. Point the antennas upward.
- Check that the voltage of the supplied AC adapter conforms to the voltage available (AC110 or AC220) in local area. Using the wrong AC adapter may cause irreparable damage to the unit.
- Plug the feeder cable of the supplied AC adapter into DC IN socket on the receiver. Then plug the AC adapter into a power outlet.

7.2 Connecting the receiver to an audio mixer or an amplifier

In order to make sure the sound quality and avoid distortion, please adjust the volume level according to following instructions.

- When using a standard audio cable with 3-pin XLR connectors or 6.3 ϕ phone plugs to plug into the **MIC IN** on the audio mixer or on the amplifier, please push the Volume Button on the receiver to **20** (approx.), the output level for balanced and unbalanced output is around at **77mV**.
- When using a standard audio cable with 3-pin XLR connectors or 6.3 ϕ phone plugs to plug into the **LINE IN** on the audio mixer or on the amplifier, please push the Volume Button on the receiver to **32**, the output level for unbalanced and balanced output is about at **770mV**.

Never use the balanced and unbalanced audio outputs at the same time! This may cause signal loss or increased noise.

7.3 Inserting batteries into the handheld / bodypack transmitter

- Open the battery cover and insert batteries into the battery compartment conforming to the polarity (+)(-) marks. The transmitter can not work with incorrectly inserted batteries.
- When push the ON/OFF switch to "ON" to switch the power on, LCD shows battery power level. If it displays insufficient power, the inserted rechargeable batteries can be charged by using the supplied DC 1.5 ϕ plug cable directly connection to DC Out on the receiver and charging input on the transmitter. It should take up to 10 hours for charging.
- Close the battery cover.

7.4 Setting up the handheld microphone transmitter

- Switch the receiver power on and check the frequency and volume level.
- Switch the transmitter and hi-fi appliance (amplifier, tape deck etc.) power on.
- Test the microphone and adjust the levels on your audio mixer or amplifier.

TROUBLE SHOOTING

7.5 Setting up the bodypack transmitter

A. Connecting a microphone

- Open the battery cover. Push the MIC/LINE switch to "MIC" and use the supplied screwdriver to adjust the GAIN at appropriate position.
- Plug the 3-pin mini XLR connector end of the microphone cable into the audio input connector on the bodypack transmitter.
- Switch the transmitter and hi-fi appliance (amplifier, tape deck etc.) power on.
- Test the microphone and adjust the levels on your audio mixer or amplifier.

B. Connecting an instrument

- Open the battery cover. Push the MIC/LINE switch to "LINE" and use the supplied screwdriver to adjust the GAIN at appropriate position.
- Plug the 6.3 ϕ phone plug of the optional guitar cable to the output jack on the instrument and the 3-pin mini XLR into audio input connector on the bodypack transmitter.
- Switch the transmitter and hi-fi appliance (amplifier, tape deck etc.) power on.
- Play the instrument for testing and adjust the levels on your audio mixer or amplifier.

8. Trouble-shooting

Problem	Solution
No sound	<ul style="list-style-type: none"> • Check the power supply of the microphone and receiver. • Check that the transmitter and receiver are tuned to the same frequency. • Check whether the hi-fi appliance is switched on and the receiver output is connected to audio mixer or amplifier input. • Check whether transmitter is too far away from receiver or SQUELCH control set too high. • Check whether receiver is located too near metal object or there are obstructions between transmitter and receiver.
Sound interference	<ul style="list-style-type: none"> • Check the antenna location. • When using 2 or above microphone sets simultaneously, make sure that the chosen frequencies are not interfered. • Check whether the interference comes from other wireless microphones, TV, radio and etc.
Distortion	<ul style="list-style-type: none"> • Check the receiver volume level is set too high or too low. • Check whether the interference comes from other wireless microphones, TV, radio and etc.

FEATURES & SPECIFICATIONS

9. System Feature

- Operating in UHF band frequency with synthesizer controlled.
- The wireless microphone system with 700 selectable frequencies via Phase Locked Loop (PLL) circuitry makes it easy to choose non-interfered channels.
- Super high sensitivity, extremely low noise transmission and reception.
- Diversity technology ensures the reception quality.

10. System Specification

Receiver

Carrier Frequency Range	: UHF band 630-806 MHz
Oscillator	: PLL synthesized
Modulation	: FM
Frequency Stability	: $\pm 0.005\%$
S/N ratio	: > 94dB, at 48KHz deviation and 60dB μ V antenna input
Image and Spurious Rejection	: 80 dB minimum
Receiving Sensitivity	: 6 dB μ V.
Selectivity	: > 50dB
AF Response	: 50Hz to 15KHz (± 3 dB)
T.H.D.	: < 1% (at 1KHz)
IF Frequency	: 1st: 56MHz; 2nd: 10.7MHz
Dynamic Range	: > 96dB
Tone Signal	: 32.768KHz
Audio Output	: Balanced and unbalanced audio outputs
Power Supply	: 12V DC
Current Consumption	: Single Channel: about 500mA Dual Channel: about 1000mA

Handheld/Bodypack Transmitter

Carrier Frequency Range	: UHF band 630-806MHz
RF Power Output	: 10mW (max.)
Oscillator	: PLL synthesized
Frequency Stability	: $\pm 0.005\%$
Maximum Deviation	: ± 48 KHz
Spurious Emission	: > 60dB below carrier frequency
T.H.D.	: < 1% (at 1KHz)
Tone Signal	: 32.768KHz
Microphone Cartridge	: Handheld: uni-directional dynamic or uni-directional electret condenser unit Lavalier: uni-directional electret condenser unit
Operating Voltage	: DC1.5V x 2 AA size dry or rechargeable batteries
Current Consumption	: 70mA \pm 5mA
Dimension (mm)	: Handheld: 266mm x 55 ϕ Bodypack: 100(L) x 65(W) x 27(D)

DESIGN AND SPECIFICATIONS SUBJECT TO CHANGE WITHOUT NOTICE.