

EXHIBIT B

Test Report

Report No.	M1215948
Specifications Test Method	FCC Part 74 – Type Acceptance ANSI C63.4 1992
Applicant address	NO. 85, CHANG HSING FIRST STREET, TAI-TZU VILLAGE, JEN-TE HSIAN, TAINAN HSIEN, TAIWAN
Applicant Items tested Model No.	WA-GOL INDUSTRIAL CO., LTD WIRELESS MICROPHONE TRANSMITTER UB-82L
Results Sample received date	As detailed within this report 02 / 26 /1998 (month / day / year)
Prepared by	<u>Stephen Chen</u> project engineer
Authorized by	<u>Jacob Lin</u> Vice General Manager (Jacob Lin)
Issue date	<u>June 8, 1998</u> (month / day / year)
Modifications	None
Tested by	Training Research Co., Ltd.
Office at	2F, No. 571, Chung Hsiao E. Road, Sec.7, Taipei, Taiwan
Open site at	No. 5-3, Lane 21, Yen Chiu Yuan Rd., Sec.4, Taipei Taiwan

Conditions of issue:

- (1). **This test report shall not be reproduced except in full, without written approval of TRC. And the test result contained within this report only relate to the sample submitted for testing.**
- (2). **This report must not be used by the client to claim product endorsement by NVLAP or nay agency of U.S. Government.**

★ FCC ID : JEBUB-82L

Contents

Chapter 0 Application for Type Acceptance.....	3
Chapter 1 General	
1.1 Introduction.....	4
1.2 Description of Support Equipment	4
1.3 Configuration of System Under Test.....	5
Chapter 2 Power Output Measurement	
2.1 Rules and Specification Limits	6
2.2 Measurement Condition & Setup.....	6
2.3 List of Measurement Instruments.....	7
2.4 Measurement Configuration.....	7
2.5 Measurement Result	8
Chapter 3 Modulation Characteristics Measurement	
3.1 Rules and Specification Limits.....	9
3.2 Test Configuration & List Of Test Instruments.....	9
3.3 Measurement Condition & Setup	10
Chapter 4 Occupied Bandwidth Measurement & Calculation	
4.1 Rules and Specification Limits.....	12
4.2 Measurement Condition & Setup	12
4.3 Measurement Result	12
Chapter 5 Field Strength of Spurious Radiation Measurement	
5.1 Rules and Specification Limits.....	15
5.2 Measurement Condition & Setup	15
5.3 List of Measurement Instruments	16
5.4 Measurement Configuration.....	16
5.5 Measurement Result	18
Chapter 6 Frequency Stability Measurement	
6.1 Rules and Specification limits	20
6.2 Measurement Condition & Setup with Temperature Variation	20
6.3 List of Measurement Instruments with Temperature Variation	20
6.4 Measurement Configuration with Temperature Variation	20
6.5 Measurement Result with Temperature Variation	21
6.6 Measurement Condition & Setup with Voltage Variation	22
6.7 List of Measurement Instruments with Voltage Variation	22
6.8 Measurement Configuration with Voltage Variation	22
6.9 Measurement Result with Voltage Variation	23

Chapter 0 Application for Type Acceptance

- 2.983 (a) : WA-GOL INDUSTRIAL CO., LTD. –applicant and manufacturer
- 2.983 (b) : The equipment is a transmitter, wireless microphone
Model : UB-82L
- 2.983 (c) : Quantity production is planned
- 2.983 (d) (1) : Type of emission – F3E- FM Modulation
- 2.983 (d) (2) : 200 Hz – 13 KHz
- 2.983 (d) (3) : 2.86 mW
- 2.983 (d) (4) : Specification of 250 mW is met by the equipment in the applicable part 74.861 (e)(1)
- 2.983 (d) (5) : Final RF amplifier stage current : 25mA, 9V Battery
- 2.983 (d) (6) : Description follows
- 2.983 (d) (7) : Complete circuit diagrams are included . No modification was made.
- 2.983 (d) (8) : Instruction sheet to user included.
- 2.983 (d) (9) : Tune up procedure follows
- 2.983 (d) (11) : Description follows
- 2.983 (d) (12) : N/A

Chapter 1 GENERAL

1.1 Introduction :

The following measurement report is submitted on behalf of WA-GOL INDUSTRIAL CO., LTD in support of a wireless microphone certification in accordance with FCC Rules . 2.981 through 2.999 and 74.861 .

Description of EUT :

EUT	:	WIRELESS MICROPHONE
Model	:	UB-82L
Carrier Frequency Range	:	614-806 MHz
RF Power Output	:	2.86 mW
Supply Voltage	:	DC 9V
Supply Current	:	25 mA
Frequency Response	:	200 Hz- 13 KHz
Frequency Stability	:	0.005%
Operating Temperature	:	-30 to +50 degree centigrade

Wireless microphone is a transmitter which operates in the frequency range of 614-806 MHz (800.75 MHz tested). This microphone is worn by a performer and other participants in a program, filming , reportingetc. The relative receiver of this microphone's FCCID : JEBUH-820 is in applying.

1.3 Configuration of test setup

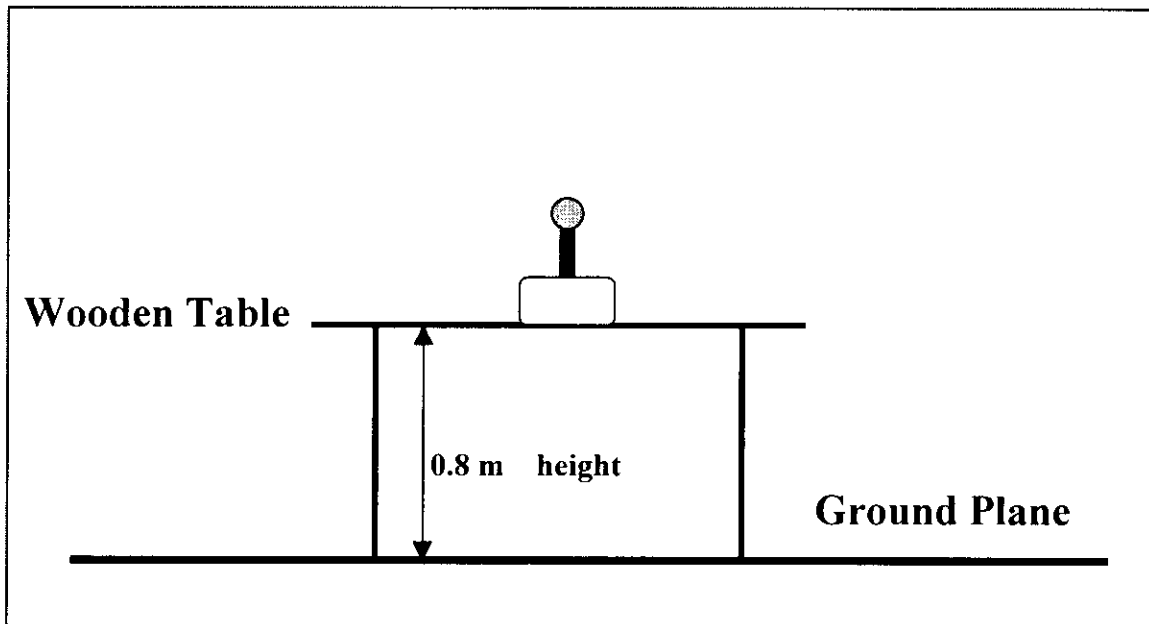

1.4 Location of the Measurement Site :

The radiated emissions measurements required by the Rules were performed on the Three-meter, open-field test site maintained by Training Research CO., Ltd., No. 5-3, Lane 21, Yen-Chiu-Yuan Rd., Sec. 4, Taipei , Taiwan , R.O.C. . Complete description and measurement data have been placed on file with the Commission. The conducted power line Emissions tests were performed in a shielded enclosure also located at the above facility . Training Research Co., Ltd. is listed by the FCC as a facility available to do measurement work for others on a contract basis .

1.5 General Test Condition :

The conditions under which the EUT operates were varied to determine their effect on the equipment's emission characteristics. The final configuration of the test system and the mode of operation used during these tests was chosen as that which produced the highest emission levels . However, only those conditions which the EUT was considered likely to encounter in normal use were investigated.

Chapter 2 Power Output Measurement

2.1 Rules and Specification Limits

2.985

74.861 (e) (1) : The power of the measured unmodulated carrier power at output of the transmitter power amplifier (antenna input power) may not exceed the following :

1. 54 – 72, 76 –88 and 174 – 216 MHz band 50mW .
2. 470 – 608 AND 614 – 806 MHz BAND 250 W.

2.2 Test condition and setup :

1. Measurement was made on open-field test site. The EUT system was placed on non-conductive turntable which is 0.8 meters height, top surface 1.0 X 1.5 meter. The EUT was placed in three direction of the space in order to obtain maximum emission.
2. A EMCO whole range antenna with horizontal and vertical polarization was raised from 1 – 4 meter as well as the turntable was rotate from 0 to 360 degree to search for the maximum Field Strength Spectrum where the spectrum analyzer was operated in the quasi-peak detection mode . Recorded all the values which measured under horizontal and vertical position for the biconical antenna .
3. The following procedures were used to convert the emission levels measured in decibels referenced to 1 microvolt (dBuV) into field intensity in Watt.

- (1) The actual field intensity in decibels referenced to 1 micro volt per meter (dBuV/m) is determined by algebraically adding the measured reading in dBuV, the antenna factor (dB), and cable loss (dB) at the appropriate frequency.

$$\mathbf{FI_a(dBuV/m) = FI_r(dBuV) + Corrected (dB)}$$

$$\mathbf{Corrected (dB) = AF(dB) + CL(dB)}$$

FI_a : Actual Field Intensity

FI_r : Reading of the Field Intensity

AF : Antenna Factor

CL : Cable Loss

- (2) The field intensity in Volt can then be determined by the following equation:

$$FI(\text{Volt}) = 10^{FI(\text{dBuV/m})/20} \times 10^{-6}$$

The field intensity in Watt can then be determined by the following equation :

$$P (\text{watt}) = FI^2(\text{ Volt}) \times d^2(\text{meter}) / 49.2$$

P : Power in Watt

D : Measurement Distance (3 M)

2.3 List of test Instrument :

Instrument name	Model No.	Brand	Serial No.	Calibration Date	
				Last	Next
Spectrum analyzer	8568B	H P	3004A18617	05/15/97	05/15/98
Quasi-peak Adapter	85650A	H P	2521A00984	05/15/97	05/15/98
RF Pre-selector	85685A	H P	2947A01011	05/15/97	05/15/98
Spectrum analyzer	8594EM	H P	3619A00198	08/07/97	08/07/98
Antenna(30M-2G Hz)	3142	EMCO	9610-1094	10/30/97	10/30/98
Open test side (Antenna ,Amplify, cable calibrated together)				05/15/97	05/15/98

The level of confidence of 95% ,the uncertainty of measurement of radiated emission is ± 4.96 dB .

2.4 Measurement Configuration

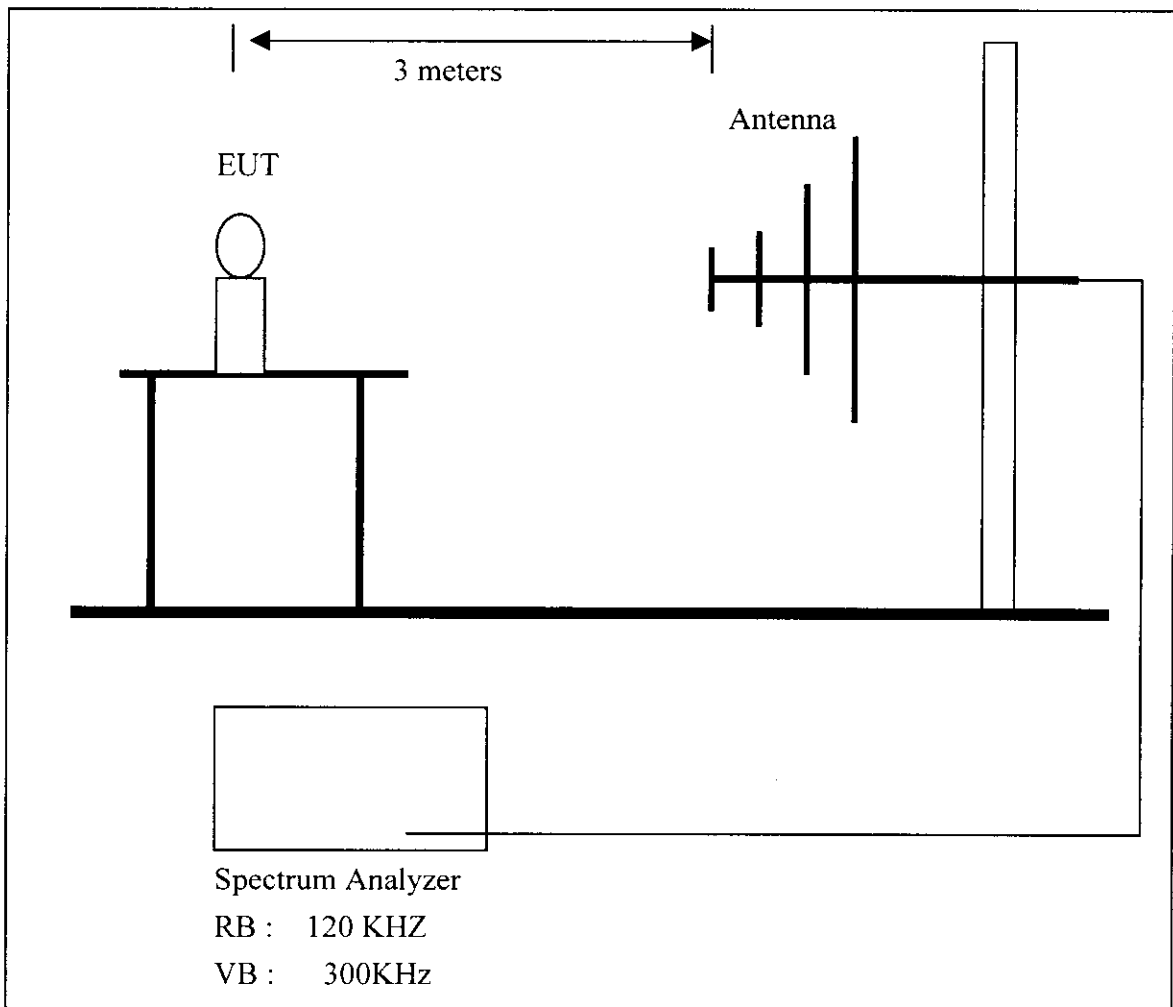

2.5 Measurement Result

$$\begin{aligned}\text{Corrected (dB)} &= \text{AF(dB)} + \text{CL(dB)} \\ &= -6.68 \text{ dB/m}\end{aligned}$$

$$\begin{aligned}\text{FI}_a(\text{dBuV/m}) &= \text{FI}_r(\text{dBuV}) + \text{Corrected (dB)} \\ &= 108.63 - 6.68 = 101.95 \text{ dBuV/m}\end{aligned}$$

The maximum field measured is 101.95 dBuV/m .

$$\text{FI (Volt)} = 10^{101.95/20} \times 10^{-6} = 0.12516\text{V}$$

$$\text{FI (mW)} = (0.12516 \times 3)^2 / 49.2 = 2.86 \text{ mW}$$

Chapter 3 Modulation Characteristics Measurement

3.1 Rules and Specification Limits

- 2.987(a) Voice modulated communication equipment
- 2.987(b) Equipment which employs modulation limiting

3.2 Test Configuration & List of Test Instruments

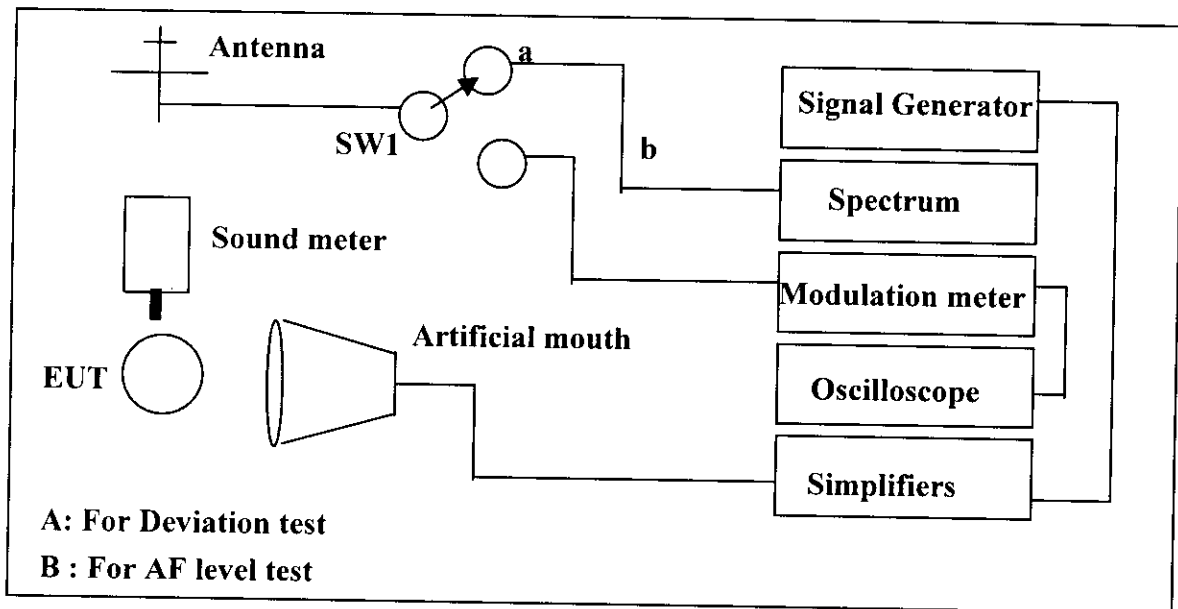

List of test instrument :

Manufacturer	Device	Model	Input Impedance
HP	100 Hz- 1.5GHz Spectrum Analyzer	HP85568B	50
HP	Signal Generator 50 MHz	HP8116A	50
Tekronix	Oscilloscope	2465B	50
Farnell	Modulation Meter	AMM2000	----
B & K	Sound meter	2235	----
Welton	Amplifier	AV-600II	----

3.3 Measurement Condition & Setup

2.987 (b)

1. SW1 switch to (a) .
2. Adjust the SG's frequency from 100 Hz to 20 KHz with the max deviation .
3. Record the deviation reading from spectrum and make a plot as chart 3-1 .
4. Adjust the SG's to frequency 600Hz with level 90.95, 100, 110 ,115, 120, 125 Dbspl.
5. Record the deviation reading showing on the spectrum at each level , and make a plot as chart 3-2 .
6. Repeat step 4 – 5 using frequency 7KHz and 12 KHz, make plots as chart 3-2, 3-3 .

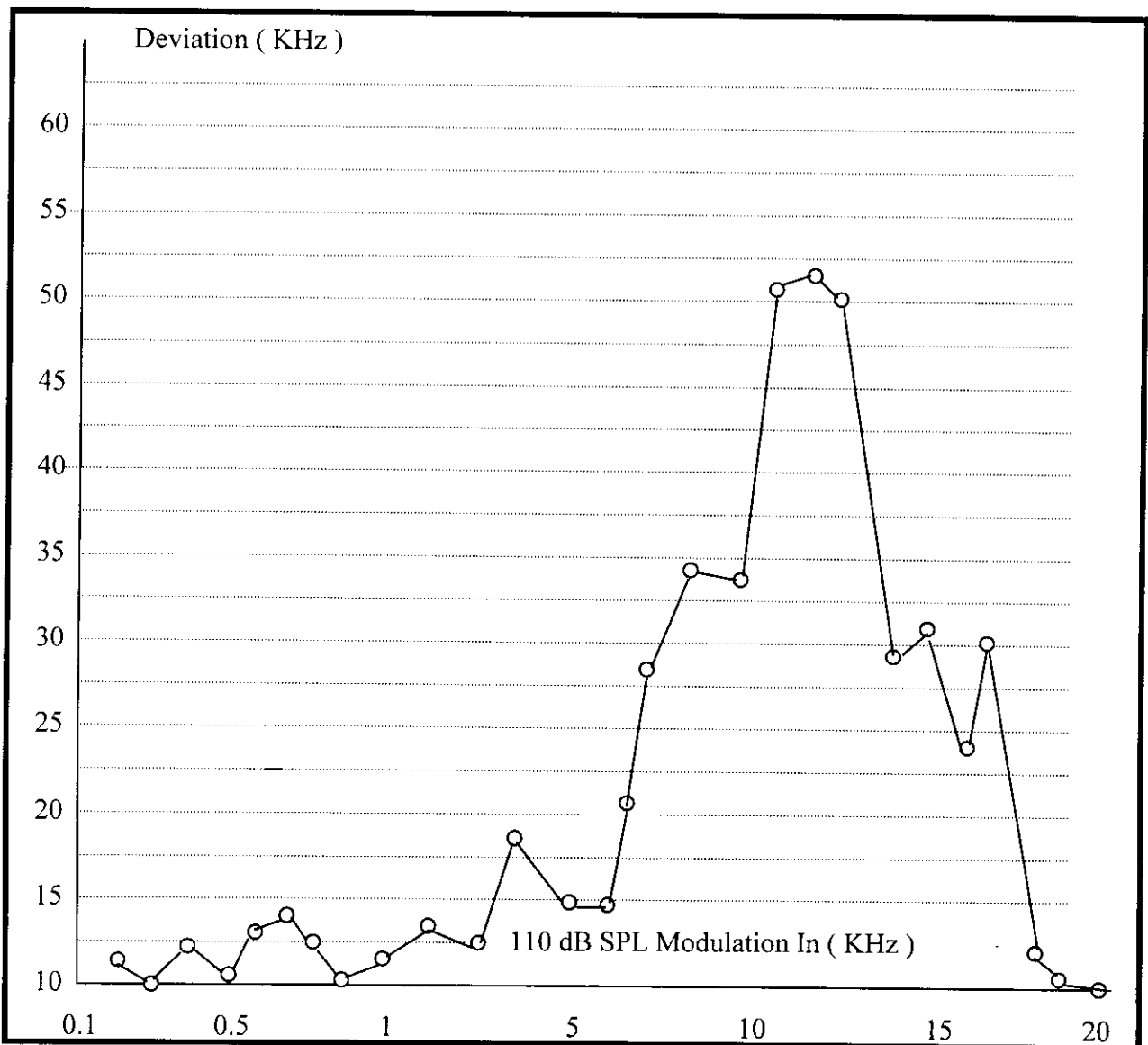
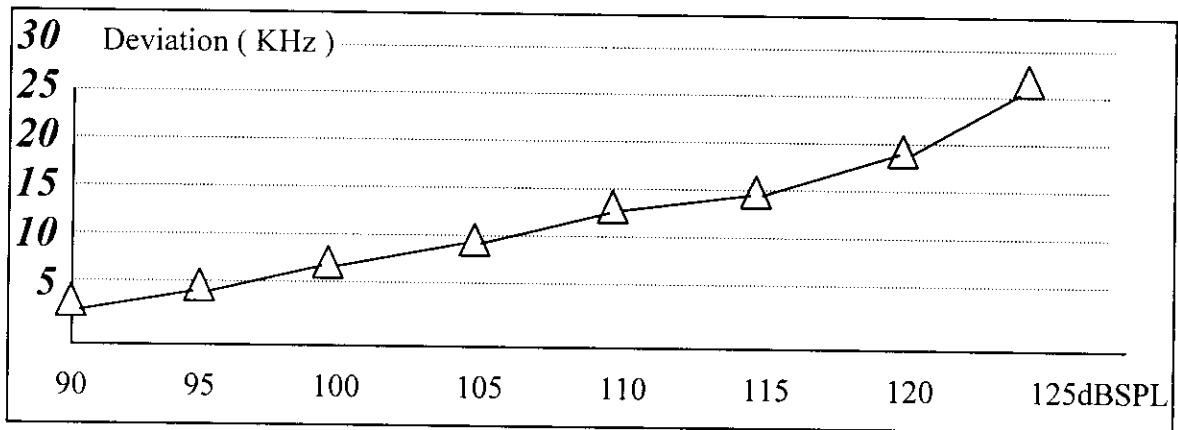

Chart 3-1 Modulation Limiting

Modulating Limiting 600 Hz

Chart 3.2



7KHz

Chart 3-3

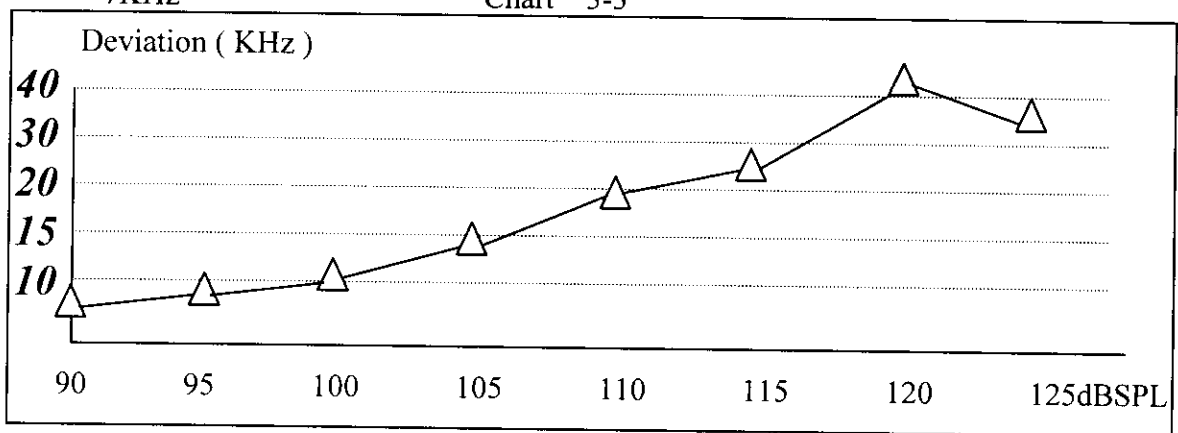

12KHz

Chart 3-4

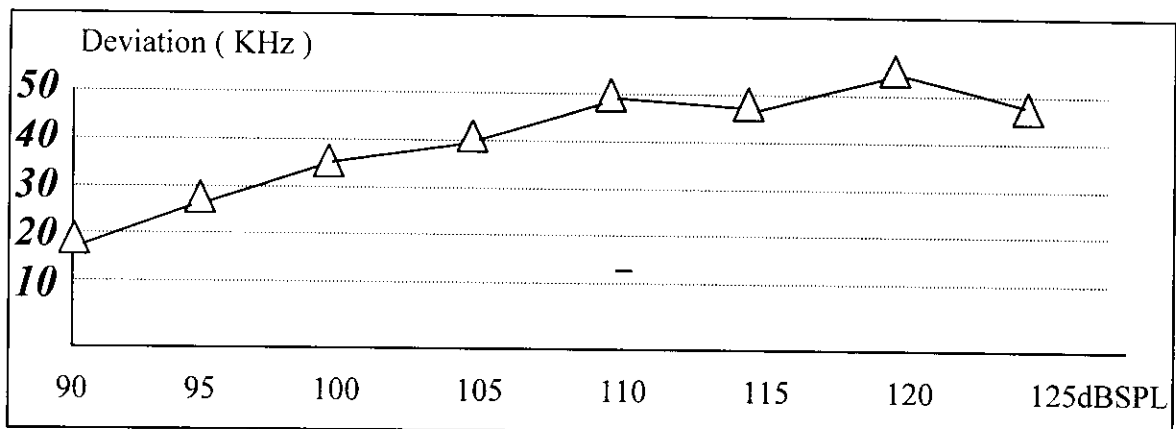

Chart 4 Occupied Bandwidth Measurement

4.1 Rules and Specification Limits

2.989 .

74.861 (e) (3) : Any form of modulation may be used . A maximum deviation of ± 75 KHz is permitted when frequency modulation is employed.

74.861 (e) (5) : The operation bandwidth shall not exceed 200 KHz .

4.2 Measurement Condition & Setup

1. Connect the EUT as Fig. SW1 switch to (a)
2. Plot the unmodulated chart shows on spectrum .
3. Set the output of the signal generator to 600Hz, 7KHz, 12KHz. Increase the amplitude of the signal, while monitoring the modulation meter .Until modulation is max. Measure the bandwidth under 26 dB compared to the unmodulated fundamental carrier peak level of the modulated signal displayed on the spectrum analyzer.

4.3 Measurement Result

The occupied bandwidth's plot is presented on following pages which illustrates compliance with the rules.

Calculation of Necessary Bandwidth (Bn)

$$B_n = 2M + 2D$$

$$M = \text{Max. Modulation Frequency} = 13 \text{ KHz (Chart 3-1)}$$

$$D = \text{Peak Frequency Deviation} = 53.11 \text{ KHz (Chart 3-4)}$$

$$K = 1$$

$$B_n = 132.22 \text{ KHz}$$

19:38:23 APR 08, 1998

REF 100.0 dBµV AT 10 dB

MKR 800.7490 MHz 88.81 dBµV

PEAK
LOG
10
dB/

CLEAR
WRITE A

MAX
HOLD A

VIEW A

BLANK A

Trace
A B C

More
1 of 4

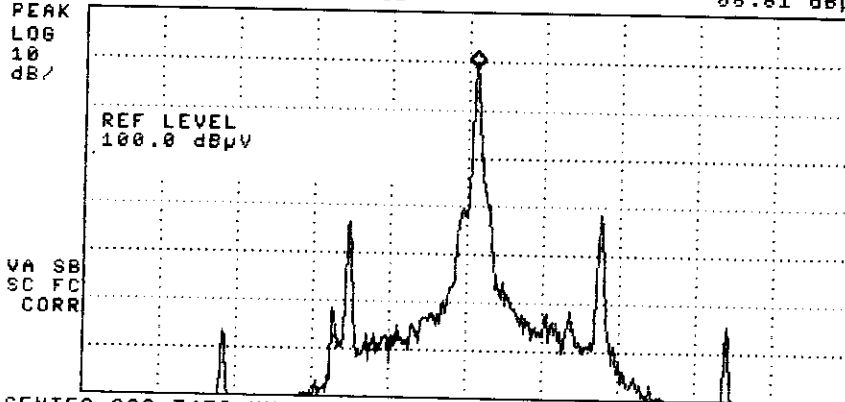

CENTER 800.7470 MHz #RES BW 300 Hz #VBW 300 Hz SPAN 200.0 kHz SWP 5.67 sec

19:39:33 APR 08, 1998

REF 100.0 dBµV AT 10 dB

MKR 82.5 kHz -1.42 dB

PEAK
LOG
10
dB/

MARKER
NORMAL

MARKER
AMPTD

SELECT
1 2 3 4

MARKER 1
ON OFF

More
1 of 3

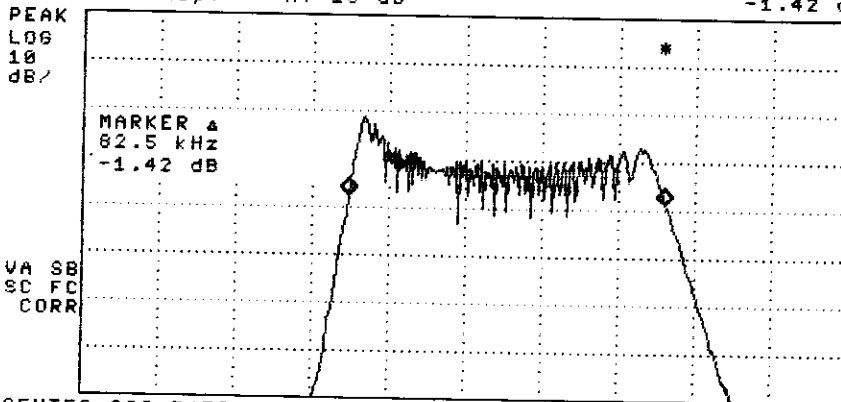

CENTER 800.7470 MHz #RES BW 300 Hz #VBW 300 Hz SPAN 200.0 kHz SWP 5.67 sec

600 Hz

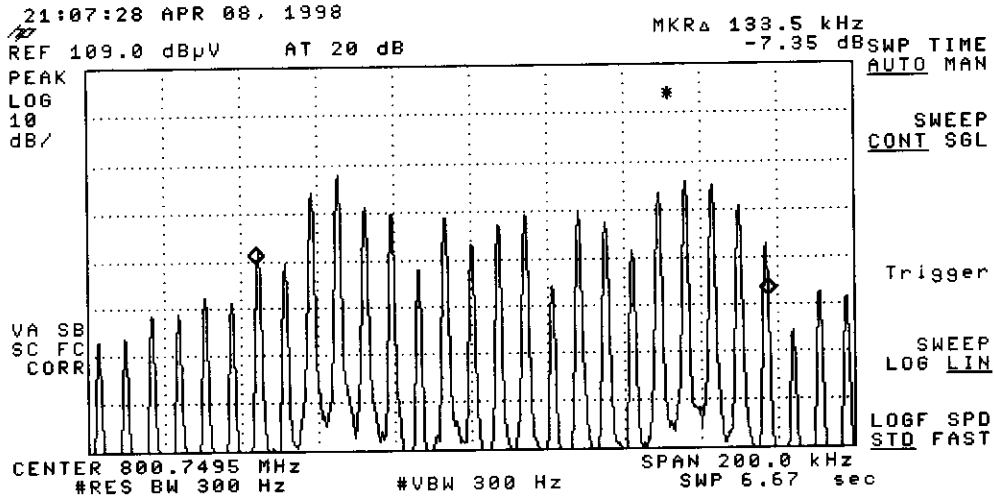

7 KHz

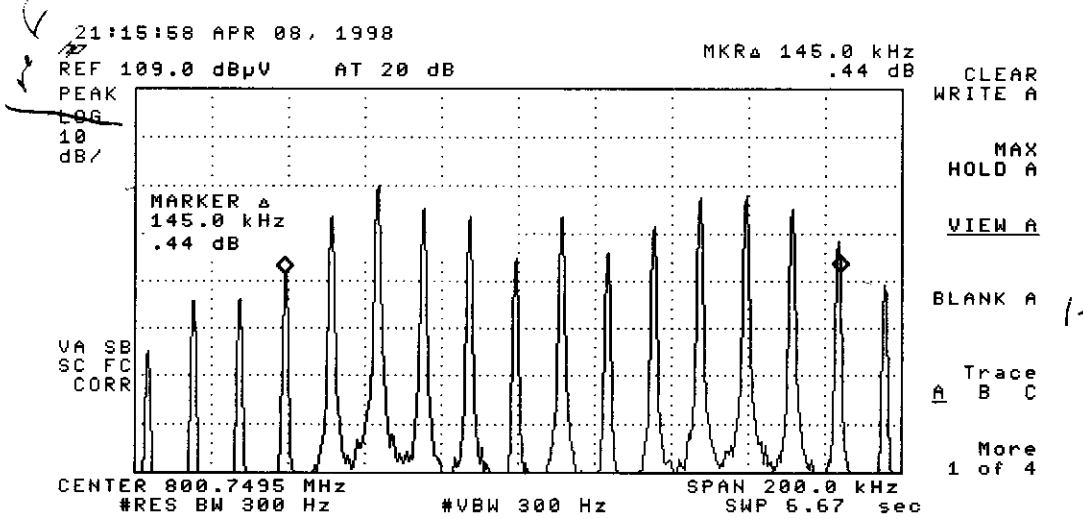

12 KHz

Chart 5. Field Strength of Spurious Radiation Measurement

5.1 Rules and Specification Limits

2.993 (a) : Measurements shall be made to detect spurious emissions that may be radiated directly from the cabinet, control circuits,. Power leads, or intermediate circuit elements under normal conditions of installation and operation.

74.861(e)(b)(iii) : Spurious and harmonics must be at least 43 + 10 log(Output Power) below the Carrier peak

2.997 : In all measurements set forth , the spectrum should be investigated from the lowest radio frequency generated in the equipment up to at least the 10th harmonic of the carrier frequency.

5.2 Measurement Condition & Setup

Pretest : Prior to the final test (OATS test) ,the EUT is placed in a shielded enclosure ,GTEM, and scan from 30MHz to 1GHz.This is done to ensure the radiation exactly emits form the EUT.

Final test : Final radiation measurements is made on a **3 - meter, open-field** test site. The EUT is placed on a nonconductive table which is 0.8 m height, the top surface is 1.0 x 1.5 meter. All the placement is according to ANSI C63.4 - 1992.

The spectrum is examined from 30 MHz to 1000 MHz measured by HP spectrum.

The EMCO whole range Antenna is used to measure frequency from 30 MHz to 1GHz.The final test is used the spectrum HP 8594EM .

Measure more than six top marked frequencies generated form pretest by computer step by step at each frequency . The EUT is rotated 360 degrees, and antenna is raised and lowered from 1 to 4 meter to find the maximum emission levels. The antenna is used with both horizontal and vertical polarization.

Appropriated preamplifier which is made by TRC is used for improving sensitivity and precautions is taken to avoid overloading .The spectrum analyzer’s 6dB bandwidth is set to 120 K Hz , and the EUT is measured at quasi-peak mode.

If the emission is close to the frequency band of ambient ,the data will be rechecked by the tester and the corrected data will be written in the test data sheet. If the emission is just within the ambient ,the data from GTEM will be taken as the final data.

The actual field intensity in decibels referenced to 1 microvolt per meter (dBuV/m) is determined by algebraically adding the measured reading in dBuV, the antenna factor (dB) and cable loss (dB) at the appropriate frequency .

$$FI_a (\text{dBuV/m}) = FI_r (\text{dBuV}) + AF (\text{dB}) + CL(\text{dB})$$

FI_a : Actual Field Intensity

FI_r : Reading of the Field Intensity

AF : Antenna Factor CL : Cable Loss

5.3 List of Measurement Instruments

Instrument name	Model No.	Brand	Serial No.	Calibration Date	
				Last	Next
Spectrum analyzer	8568B	HP	3004A18617	05/15/97	05/15/98
Quasi-peak Adapter	85650A	HP	2521A00984	05/15/97	05/15/98
RF Pre-selector	85685A	HP	2947A01011	05/15/97	05/15/98
Spectrum analyzer	8594EM	HP	3619A00198	08/07/97	08/07/98
Antenna(30M-2G Hz)	3142	EMCO	9610-1094	10/30/97	10/30/98
Open test side (Antenna ,Amplify, cable calibrated together)				05/15/97	05/15/98

The level of confidence of 95% ,the uncertainty of measurement of radiated emission is ± 4.96 dB .

5.4 Measurement Configuration

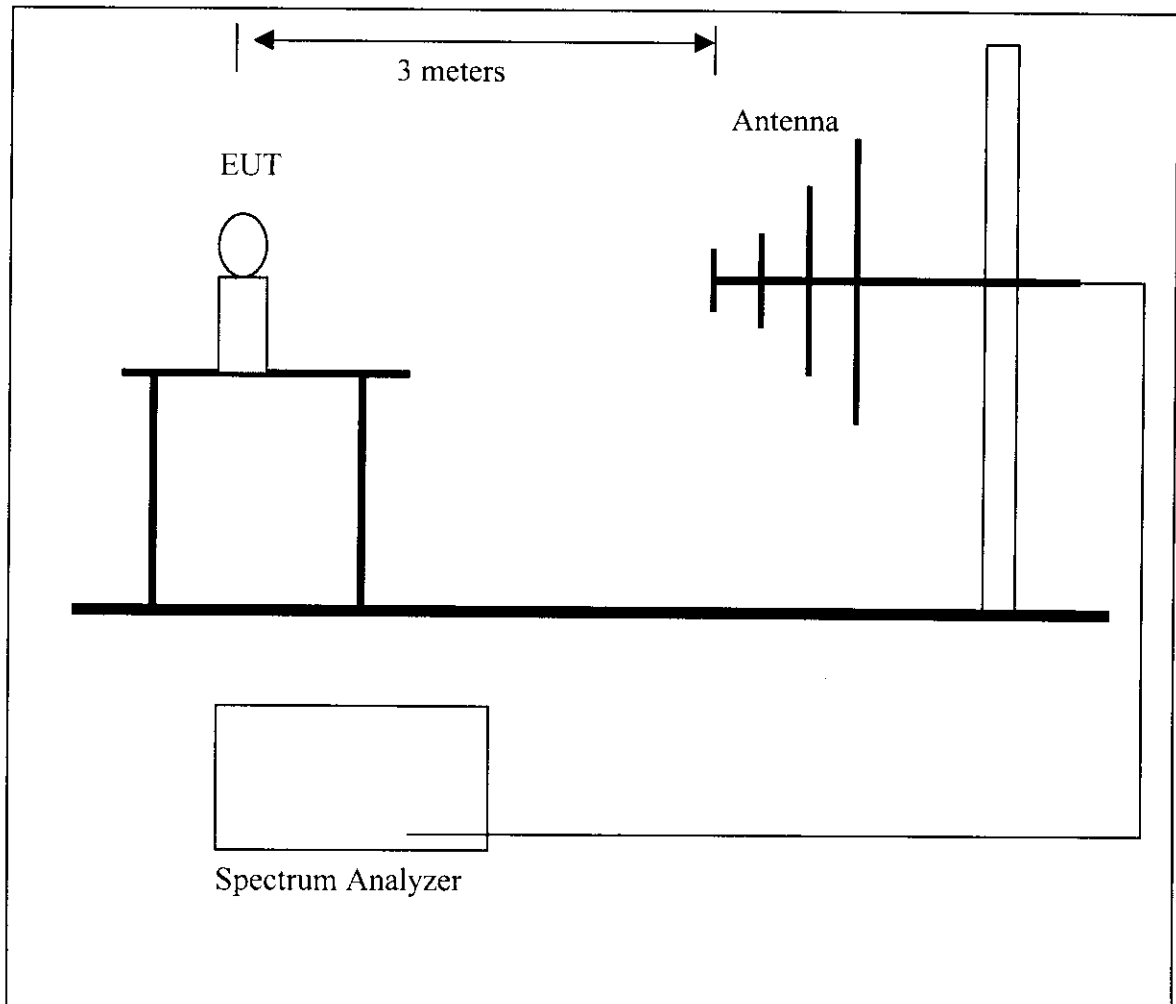

5.5 Measurement Result :(Horizontal)

Test Conditions:

Testing room : Temperature : 20° C Humidity : 71% RH
 Testing site : Temperature : 16 ° C Humidity : 85 % RH

Frequency	Reading	Ant.	Table	Correction	Corrected		Margin
	Amplitude	Height		Factors	Amplitude	limit	
MHz	dBuV	m	degree	dB/m	dBuV/m	dBuV/m	dB
276.848	39.97	1	318	-6.06	33.91	84.39	-50.48
400.376	58.46	1	292	-16.96	41.50	84.39	-42.89
600.566	53.29	1	13	-9.91	43.38	84.39	-41.01
750.705	47.01	1	240	-6.90	40.11	84.39	-44.28
784.069	41.49	1	138	-6.73	34.76	84.39	-49.63
817.433	44.16	1	59	-6.60	37.56	84.39	-46.83
850.799	48.33	1	61	-6.25	42.08	84.39	-42.31
900.844	45.87	1	313	-5.59	40.28	84.39	-44.11

Note:

1. Margin = Amplitude - limit, *if margin is minus means under limit.*
2. Corrected Amplitude = Reading Amplitude - Correction Factors
3. Correction factor = Antenna factor + (Cable Loss - Amplitude gain)
- (For example : 30MHz correction factor = 15.5 + (-15.26) = 0.24 dB/m)
4. Attenuation required = 43 + 10 log (2.86 mW) = 17.56

Limit = 101.95 - 17.56 = 84.39

L₁₉

L₁₉ = 65 (everything is below carrier ref)

limit also

Radiated Emission Test Result :(Vertical)

Frequency	Reading	Ant. Table	Correction	Corrected	Margin		
MHz	Amplitude	Height	Factors	Amplitude	limit		
	dBuV	m	degree	dB/m	dBuV/m	dB	
276.848	40.53	1	189	-6.06	34.47	84.39	-49.92
400.376	72.24	1	49	-16.96	55.28	84.39	-29.11
600.566	51.56	1	165	-9.91	41.65	84.39	-42.74
750.705	52.31	1	86	-6.90	45.41	84.39	-38.98
784.069	52.97	1	200	-6.73	46.24	84.39	-38.15
817.433	55.33	1	125	-6.60	48.73	84.39	-35.66
850.799	61.74	1	119	-6.25	55.49	84.39	-28.90
900.844	57.39	1	211	-5.59	51.80	84.39	-32.59

Chart 6 Frequency Stability Tolerance Measurement

6.1 Rules and Specification Limits

2.995

74.861(e)(4): The frequency tolerance of the transmitter shall be 0.005 percent.

6.2 Measurement Condition & Setup with Temperature Variation

1. Place the EUT in the chamber, powered in its normal operation .
2. Set the temperature of the chamber –30 degree Centigrade. Allow the equipment to stabilize at that temperature .
3. Measured the carrier frequency using preamplifier and frequency counter.
4. Repeated procedures 1 to 3 from –20 to 50 degree Centigrade at internals of 10 degree.

6.3 List of Measurement Instruments with Temperature Variation

List of test Instrument :

Instrument name	Model No.	Brand	Remark
Spectrum Analyzer	8591A	H P	1.8GHz
Temperature Chamber	THS-MV2	King Son	
Near field Probe	7405-901	EMCO	
Power Supply			
Auto Transformer	Powerstat	Supprior Elec. Co.	

6.4 Measurement Configuration of Temperature variation test :

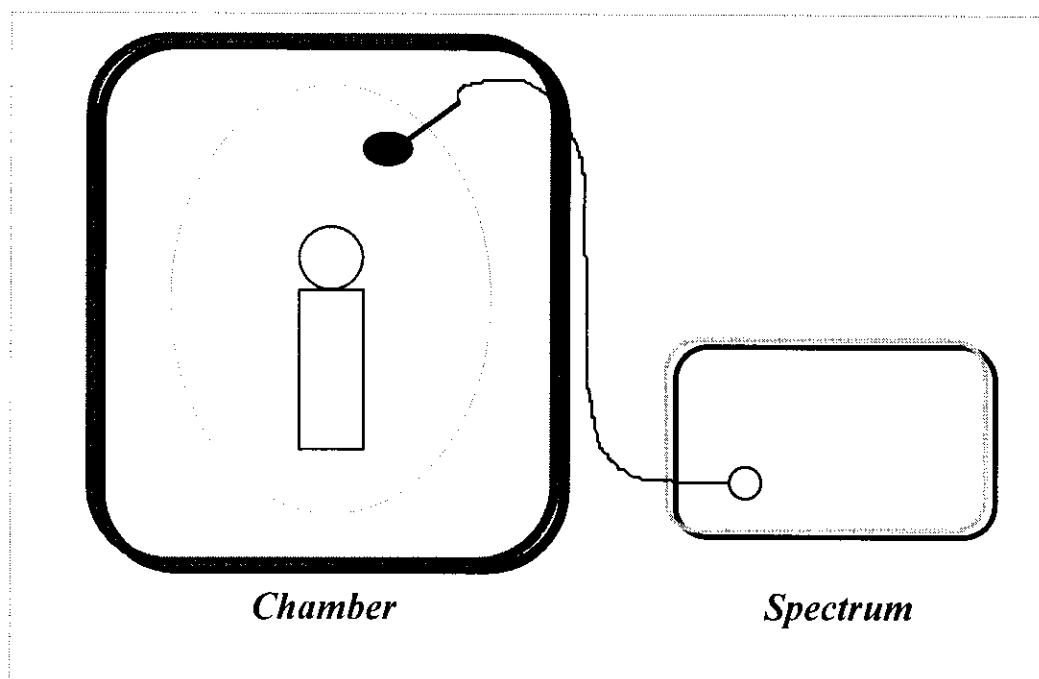

6.5 Measurement Result with Temperature Variation

A plot and table is presented which illustrates compliance with the rule where the center frequency is 800.75 MHz.

Temperature Variation Table

Temperature (Centigrade)	Frequency (MHz)	Tolerance (MHz)
-30	800.75872	800.35000~801.15000
-20	800.75304	800.35000~801.15000
-10	800.75189	800.35000~801.15000
0	800.75136	800.35000~801.15000
10	800.75274	800.35000~801.15000
20	800.75073	800.35000~801.15000
30	800.74975	800.35000~801.15000
40	800.74876	800.35000~801.15000
50	800.74764	800.35000~801.15000

Temperature Variation Vs. Frequency Chart

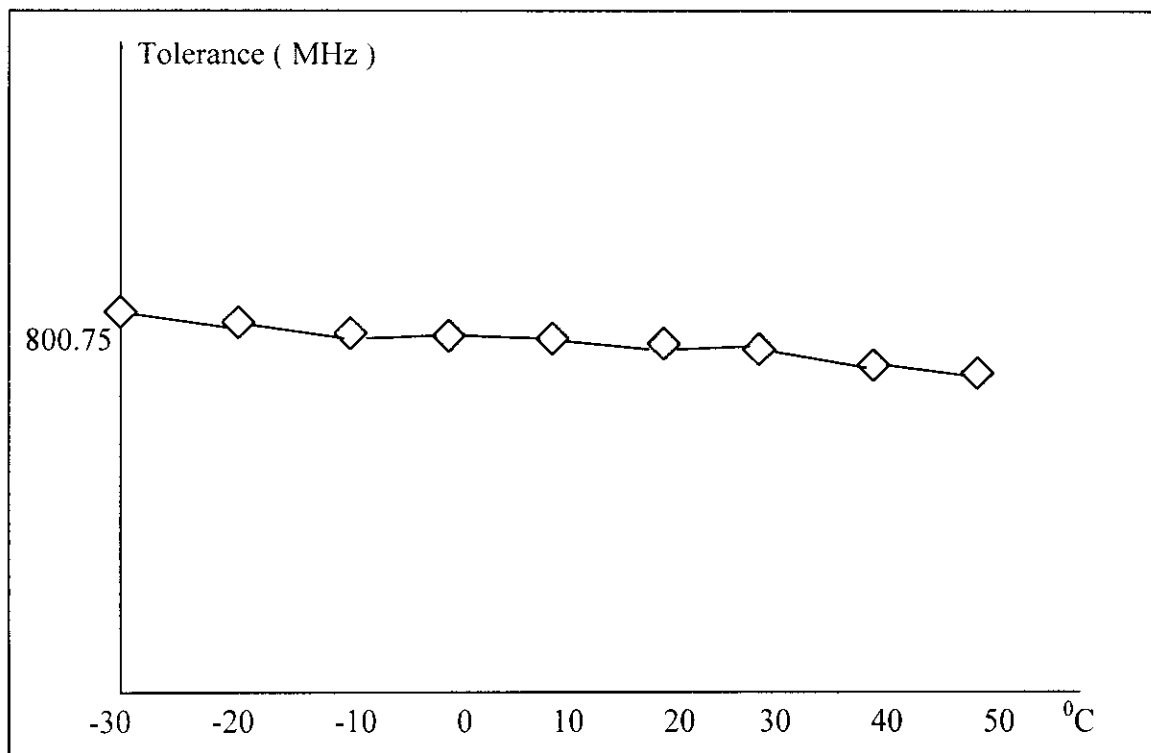

6.6 Measurement Condition & Setup with Voltage Variation

1. Attached the power line of the power supply to the battery position of the EUT.
2. Tuned the output power level to battery end point , 85 % , 100%, 115% of the normal operation power of EUT.
3. Recorded the frequency with a frequency counter .

6.7 List of test Instrument :

Instrument name	Model No.	Brand	Remark
Spectrum Analyzer	8591A	H P	1.8GHz
Temperature Chamber	THS-MV2	King Son	
Near field Probe	7405-901	EMCO	
Power Supply			
Auto Transformer	Powerstat	Supprior Elec. Co.	

6.8 Configuration of Voltage variation test :

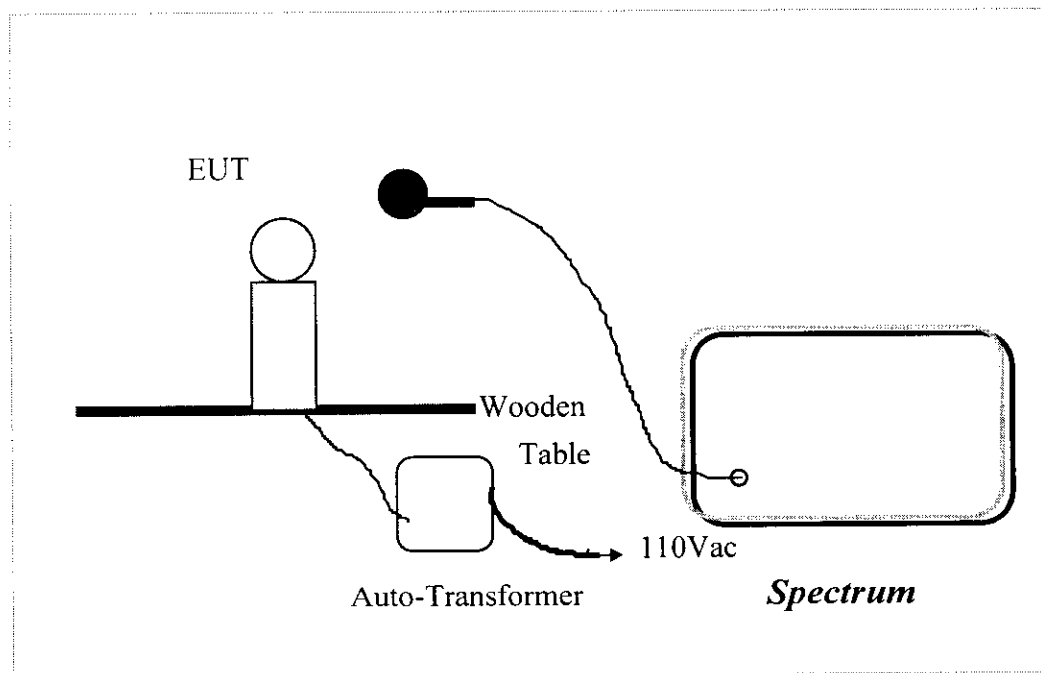

6.9 Measurement Result with Voltage Variation

Frequency Stability of Voltage Variation Measurement Table

Supply Voltage (Volt)	Frequency (MHz)	Tolerance (MHz)
7.65 (85%)	800.75681	800.35000~801.15000
9.00 (100%)	800.75063	800.35000~801.15000
10.35 (115%)	800.75281	800.35000~801.15000
Endpoint-Voltage 3.94V		

Voltage Variation Vs. Frequency Chart

