

EXHIBIT B

Test Report

Report No.	M1274232
Specifications	FCC Part 74 – Certification
Test Method	ANSI C63.4 1992
Applicant address	NO. 85, CHANG HSING FIRST STREET, TAI-TZU VILLAGE, JEN-TE HSIAN, TAINAN HSIEN, TAIWAN, R.O.C.
Applicant Items tested	WA-GOL INDUSTRIAL CO., LTD. WIRELESS MICROPHONE TRANSMITTER
Model No.	MX-N15G
Results	Compliance (As detailed within this report)
Sample received date	04/23/1999 (month / day / year)
Prepared by	 project engineer
Authorized by	 General Manager (Frank Tsai)
Issue date	Nov. 30, 1999 (month / day / year)
Modifications	None
Tested by	Training Research Co., Ltd.
Office at	2F, No. 571, Chung Hsiao E. Road, Sec.7, Taipei, Taiwan
Open site at	No. 5-3, Lane 21, Yen Chiu Yuan Rd., Sec.4, Taipei Taiwan

Conditions of issue:

- (1) This test report shall not be reproduced except in full, without written approval of TRC. And the test result contained within this report only relate to the sample submitted for testing.**
- (2) This report must not be used by the client to claim product endorsement by NVLAP or nay agency of U.S. Government.**

★ FCC ID : JEBMX-N15G

Contents

Chapter 0 Application for Certification	4
Chapter 1 General	
1.1 Introduction	5
1.2 Description of Support Equipment.....	5
1.3 Configuration of System Under Test.....	6
1.4 Location of the Measurement Site	6
1.5 General Test Condition	6
Chapter 2 Power Output Measurement	
2.1 Rules and Specification Limits	7
2.2 Measurement Condition and Setup	7
2.3 List of Measurement Instrument	8
2.4 Measurement Configuration.....	9
2.5 Measurement Result.....	10
Chapter 3 Modulation Characteristics Measurement	
3.1 Rules and Specification Limits	11
3.2 Test Configuration & List of Test Instruments	11
3.3 Measurement Condition & Setup.....	12
3.4 Frequency Response of Audio Low Pass Filter Measurement Condition & Setup ...	12
3.5 Modulation Limiting Measurement Condition & Setup	12
Chapter 4 Occupied Bandwidth Measurement & Calculation	
4.1 Rules and Specification Limits	15
4.2 Test Condition & Test Instruments	15
4.3 Measurement Procedure.....	16
4.4 Measurement Result.....	16

Chapter 5 Field Strength of Spurious Radiation Measurement

5.1 Rules and Specification Limits	17
5.2 Measurement Condition & Setup.....	17
5.3 List of Measurement Instruments.....	18
5.4 Measurement Configuration.....	19
5.5 Measurement Result.....	21

Chapter 6 Frequency Stability Tolerance Measurement

6.1 Rules and Specification limits.....	33
6.2 Measurement Condition & Setup with Temperature Variation	33
6.3 List of Measurement Instruments with Temperature Variation	33
6.4 Measurement Configuration with Temperature Variation	34
6.5 Measurement Result with Temperature Variation	35
6.6 Measurement Condition & Setup with Voltage Variation	36
6.7 List of Measurement Instruments with Voltage Variation.....	36
6.8 Measurement Configuration with Voltage Variation.....	36
6.9 Measurement Result with Voltage Variation	37

Chapter 0 Application for Certification

- 2.983 (a) : WA-GOL INDUSTRIAL CO., LTD. – applicant and manufacturer
- 2.983 (b) : The equipment is a transmitter, wireless microphone
Model No.: MX-N15G
- 2.983 (c) : Quantity production is planned
- 2.983 (d) (1) : Type of emission – F3E- FM Modulation
- 2.983 (d) (2) : 100 Hz ~ 3.044 KHz
- 2.983 (d) (3) : 0.029 mW
- 2.983 (d) (4) : Specification of 250 mW is met by the equipment in the applicable part 74.861 (e)(1)
- 2.983 (d) (5) : Final RF amplifier stage current : 25mA, 9V Battery
- 2.983 (d) (6) : Description follows
- 2.983 (d) (7) : Complete circuit diagrams are included . No modification was made.
- 2.983 (d) (8) : Instruction sheet to user included.
- 2.983 (d) (9) : Tune up procedure follows
- 2.983 (d) (11) : Description follows
- 2.983 (d) (12) : N/A

Chapter 1 GENERAL

1.1 Introduction :

The following measurement report is submitted on behalf of **WA-GOL INDUSTRIAL CO., LTD** in support of a wireless microphone certification in accordance with FCC Rules. 2.981 through 2.999 and 74.861.

Description of EUT :

EUT	:	WIRELESS MICROPHONE TRANSMITTER
Model No.	:	MX-N15G
Carrier Frequency Range	:	174 ~ 216 MHz
RF Power Output	:	0.029 mW
Supply Voltage	:	DC 9V
Supply Current	:	25 mA
Frequency Response	:	100 Hz ~ 3.044 KHz
Frequency Stability	:	0.005%
Operating Temperature	:	- 30 to + 50 degree centigrade

Wireless microphone is a transmitter which operates in the frequency range of 174 ~ 216 MHz. (174.600MHz, 195.600MHz, 215.600MHz tested) This microphone is worn by a performer and other participants in a program, filming, reporting ...etc. The relative receiver of this microphone's Model No.: MR-H12Bis in applying.

1.2 Description of Support Equipment :

N/A

1.3 Configuration of test setup

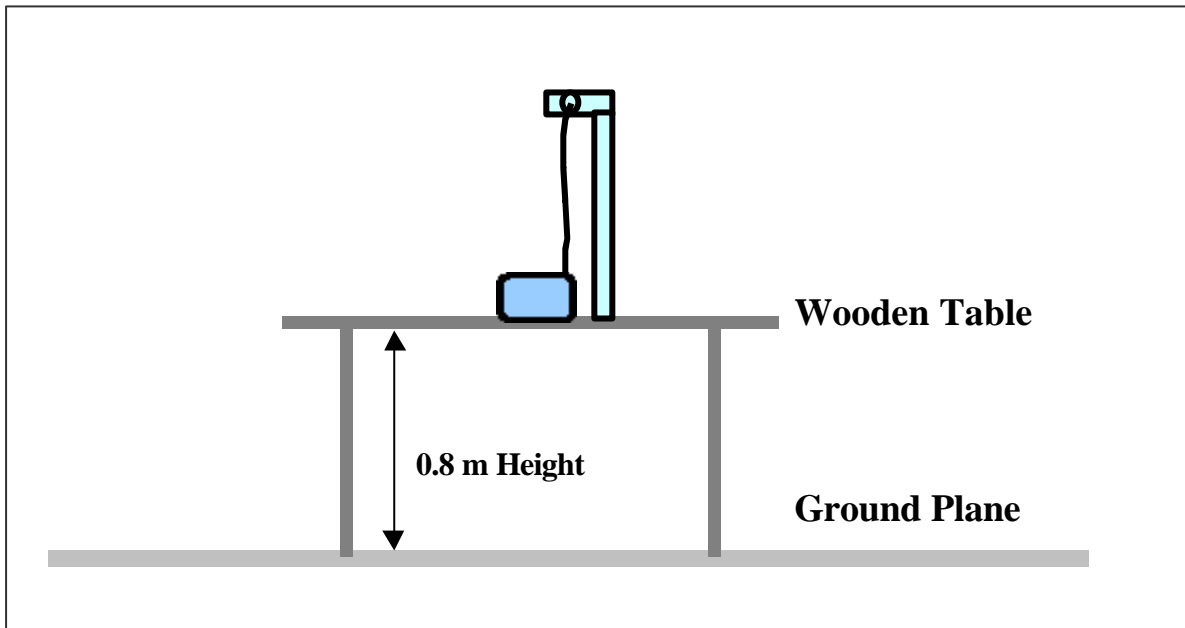

1.4 Location of the Measurement Site :

The radiated emissions measurements required by the Rules were performed on the Three-meter, open-field test site maintained by *Training Research CO., Ltd., No. 5-3, Lane 21, Yen-Chiu-Yuan Rd., Sec. 4, Taipei, Taiwan, R.O.C.* Complete description and measurement data have been placed on file with the Commission. The conducted power line Emissions tests were performed in a shielded enclosure also located at the above facility.

Training Research Co., Ltd. is listed by the FCC as a facility available to do measurement work for others on a contract basis.

1.5 General Test Condition :

The conditions under which the EUT operates were varied to determine their effect on the equipment's emission characteristics. The final configuration of the test system and the mode of operation used during these tests was chosen as that which produced the highest emission levels. However, only those conditions, which the EUT was considered likely to encounter in normal use were investigated.

Chapter 2 Power Output Measurement

2.1 Rules and Specification Limits

2.985

74.861 (e)(1): The power of the measured unmodulated carrier power at output of the transmitter power amplifier (antenna input power) may not exceed the following:

1. 54 – 72, 76 – 88 and 174 – 216 MHz band 50 mW.
2. 470 – 608 AND 614 – 806 MHz band 250 mW.

2.2 Test condition and setup :

1. Measurement was made on open-field test site. The EUT system was placed on non-conductive turntable which is 0.8 meters height, top surface 1.0 X 1.5 meter. The EUT was placed in three direction of the space in order to obtain maximum emission.
2. A EMCO whole range antenna with horizontal and vertical polarization was raised from 1 – 4 meter as well as the turntable was rotate from 0 to 360 degree to search for the maximum Field Strength Spectrum where the spectrum analyzer was operated in the quasi-peak detection mode. Recorded all the values, which measured under horizontal and vertical position for the biconical antenna.
3. The following procedures were used to convert the emission levels measured in decibels referenced to 1 microvolt (dB μ V) into field intensity in Watt.
 - (1) The actual field intensity in decibels referenced to 1 micro volt per meter (dB μ V/m) is determined by algebraically adding the measured reading in dB μ V, the antenna factor (dB), and cable loss (dB) at the appropriate frequency.
 - (2) The field intensity in Volt can then be determined by the following equation:
$$FI(\text{Volt}) = 10^{FI(\text{dB}\mu\text{V}/\text{m}) / 20} \times 10^{-6}$$

$$FI_a(\text{dB}\mu\text{V}/\text{m}) = FI_r(\text{dB}\mu\text{V}) + \text{Corrected (dB)}$$

$$\text{Corrected (dB)} = AF(\text{dB}) + CL(\text{dB})$$

FI_a : Actual Field Intensity

FI_r : Reading of the Field Intensity

AF : Antenna Factor

CL : Cable Loss

The field intensity in Watt can then be determined by the following equation :

$$P (\text{watt}) = FI^2 (\text{ Volt}) \times d^2 (\text{meter}) / 49.2$$

P : Power in Watt

D : Measurement Distance (3 m)

2.3 List of test Instrument :

Instrument Name	Model No.	Brand	Serial No.	Calibration Date	
				Last time	Next time
Spectrum analyzer	8568B	H P	3004A18617	05/15/99	05/15/00
Quasi-peak Adapter	85650A	H P	2521A00984	05/15/99	05/15/00
RF Pre-selector	85685A	H P	2947A01011	05/15/99	05/15/00
Spectrum analyzer	8591A	H P	2919A00263	01/07/99	01/07/00
Antenna (30M-2G Hz)	3142	EMCO	1296	06/10/99	06/10/00
Open test side (Antenna, Amplify, cable calibrated together)				05/15/99	05/15/00

The level of confidence of 95%, the uncertainty of measurement of radiated emission is ± 4.96 dB.

2.4 Measurement Configuration

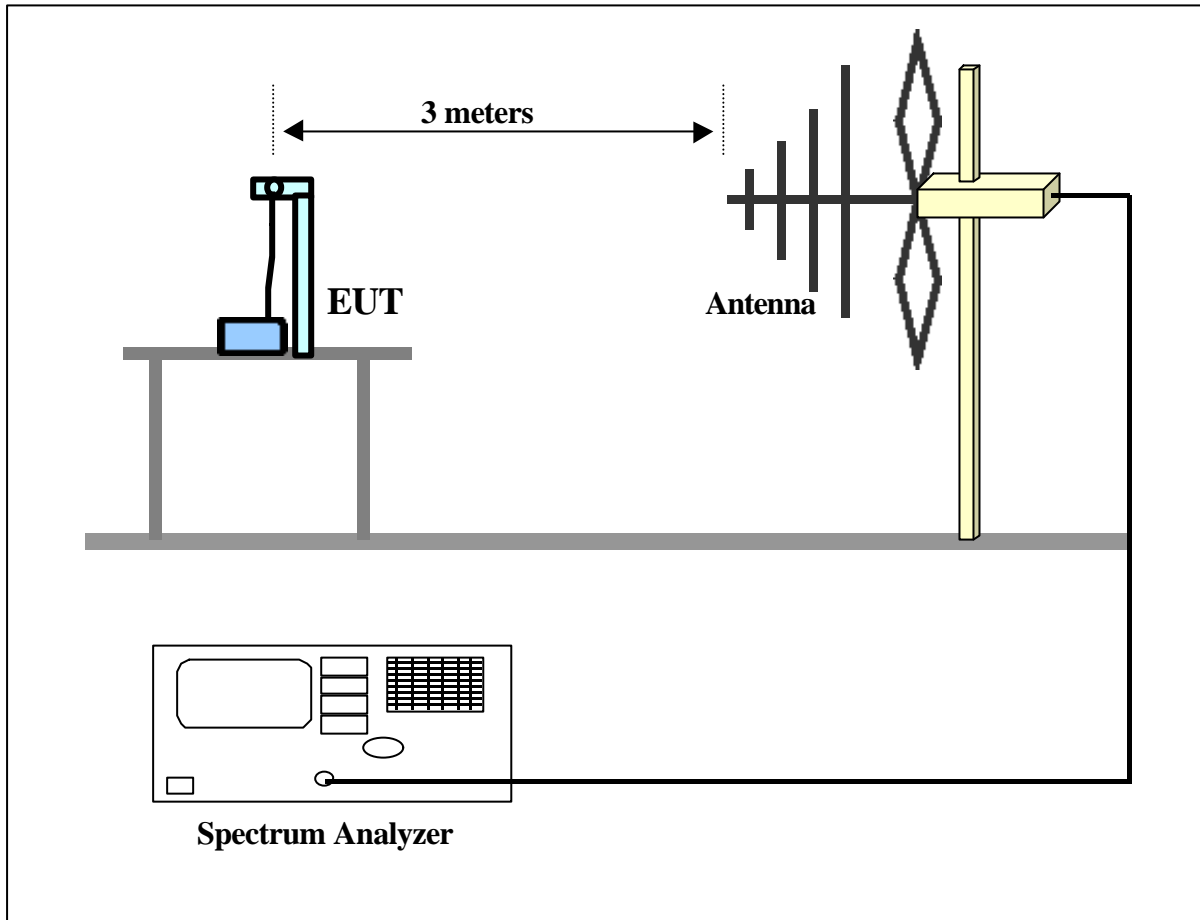

2.5 Measurement Result

(1) Frequency: 174.600 MHz

$$\begin{aligned}\text{Corrected (dB)} &= \text{AF(dB)} + \text{CL(dB)} \\ &= -12.85 \text{ dB/m}\end{aligned}$$

$$\begin{aligned}\text{FI}_a \text{ (dB}\mu\text{V/m)} &= \text{FI}_r \text{ (dB}\mu\text{V)} - \text{Corrected (dB)} \\ &= 37.60 - (-12.85) \\ &= 50.45 \text{ dB}\mu\text{V/m}\end{aligned}$$

The maximum field measured is 50.45 dB μ V/m

$$\text{FI (Volt)} = 10^{50.45/20} \times 10^{-6} = 0.00033 \text{ V}$$

$$\text{FI (mW)} = (0.00033 \times 3)^2 / 49.2 = 0.000020 \text{ mW}$$

(2) Frequency: 195.600 MHz

$$\begin{aligned}\text{Corrected (dB)} &= \text{AF(dB)} + \text{CL(dB)} \\ &= -13.13 \text{ dB/m}\end{aligned}$$

$$\begin{aligned}\text{FI}_a \text{ (dB}\mu\text{V/m)} &= \text{FI}_r \text{ (dB}\mu\text{V)} - \text{Corrected (dB)} \\ &= 51.01 - (-13.13) \\ &= 64.31 \text{ dB}\mu\text{V/m}\end{aligned}$$

The maximum field measured is 64.31 dB μ V/m

$$\text{FI (Volt)} = 10^{64.31/20} \times 10^{-6} = 0.00164 \text{ V}$$

$$\text{FI (mW)} = (0.00164 \times 3)^2 / 49.2 = 0.000493 \text{ mW}$$

(3) Frequency: 215.600 MHz

$$\begin{aligned}\text{Corrected (dB)} &= \text{AF(dB)} + \text{CL(dB)} \\ &= -14.73 \text{ dB/m}\end{aligned}$$

$$\begin{aligned}\text{FI}_a \text{ (dB}\mu\text{V/m)} &= \text{FI}_r \text{ (dB}\mu\text{V)} - \text{Corrected (dB)} \\ &= 67.20 - (-14.73) \\ &= 81.93 \text{ dB}\mu\text{V/m}\end{aligned}$$

The maximum field measured is 81.93 dB μ V/m

$$\text{FI (Volt)} = 10^{81.93/20} \times 10^{-6} = 0.01249 \text{ V}$$

$$\text{FI (mW)} = (0.01249 \times 3)^2 / 49.2 = 0.028528 \text{ mW}$$

Chapter 3 Modulation Characteristics Measurement

3.1 Rules and Specification Limits

1. 987(a): Voice modulated communication equipment
2. 987(b): Equipment which employs modulation limiting

3.2 Test Configuration & List of Test Instruments

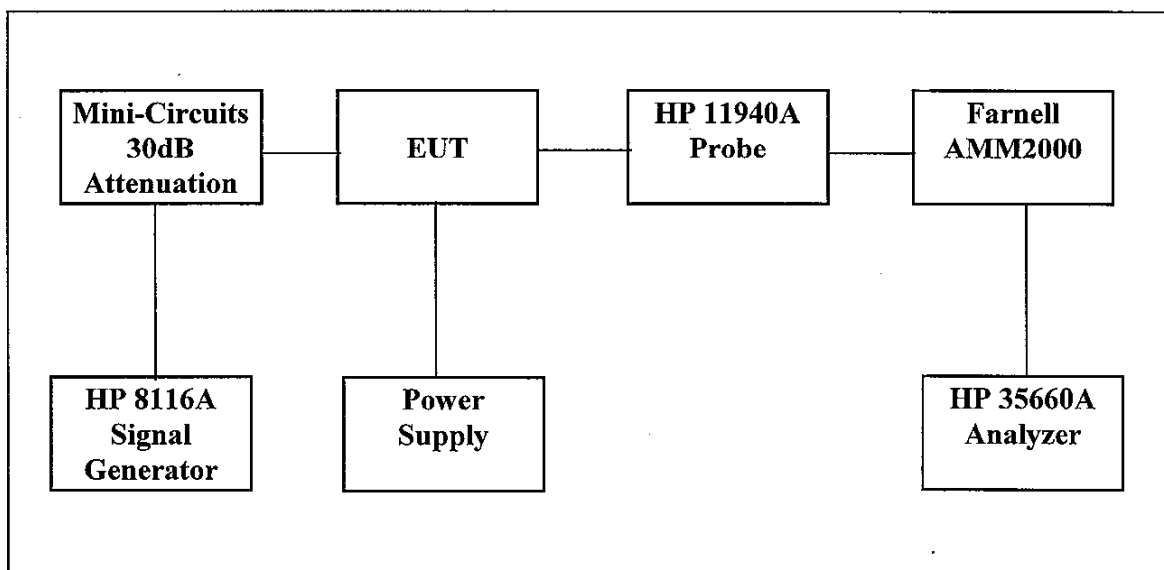

List of test instrument :

Manufacturer	Device	Model No.	Input Impedance
HP	Dynamic Signal Analyzer	HP35660A	50
HP	Signal Generator 50 MHz	HP8116A	50
Farnell	Modulation Meter	AMM2000	---
HP	Close-Field Probe 30M~1GHz	11940A	---

3.3 Frequency Response of Audio Modulation Circuit Measurement

Condition & Setup

2.987 (a)

1. The EUT and test equipment were set up as shown on the Section 4.2 .
2. The Plus/Function generator was connected to the audio input circuit/microphone of the EUT.
3. The audio signal input was adjusted to obtain 50% modulation at 1 KHz.
4. With input levels held constant and below limiting at all frequencies, the generator was varied from 100 Hz to 51.3 kHz.
5. The response in dBVrms relative to 1kHz was then measured, using the HP 35660A Dynamic Signal Analyzer as follow page.

3.4 Frequency Response of Audio Low Pass Filter Measurement Condition & Setup

1. The measurement condition and setup as Section 3.3 .
2. With input levels held constant and below limiting at all frequencies, the generator was varied from 100Hz to 102.5kHz.
3. The response in dBVrms relative to 1kHz was then measured, using the HP 35660A Dynamic Signal Analyzer as follow page.

3.5 Modulation Limiting Measurement Condition & Setup

1. The signal generator was connected to the input of the EUT as for “Frequency Response of the Modulating Circuit”.
2. The modulation response was measured for each of three frequencies: 100Hz, 600Hz, 996Hz, 2.020KHz and 3.044KHz.
3. The input level was varied from 30% modulation to at least 20 dB higher than the saturation point.
4. Measurements were performed for both negative and positive modulation and the respective results were recorded.
5. Measurement results as Chart 3.1 to 3.2

Number: 10
Overlap: 0%

Update Rate: 5

AVERAGE IN PROGRESS

Meas

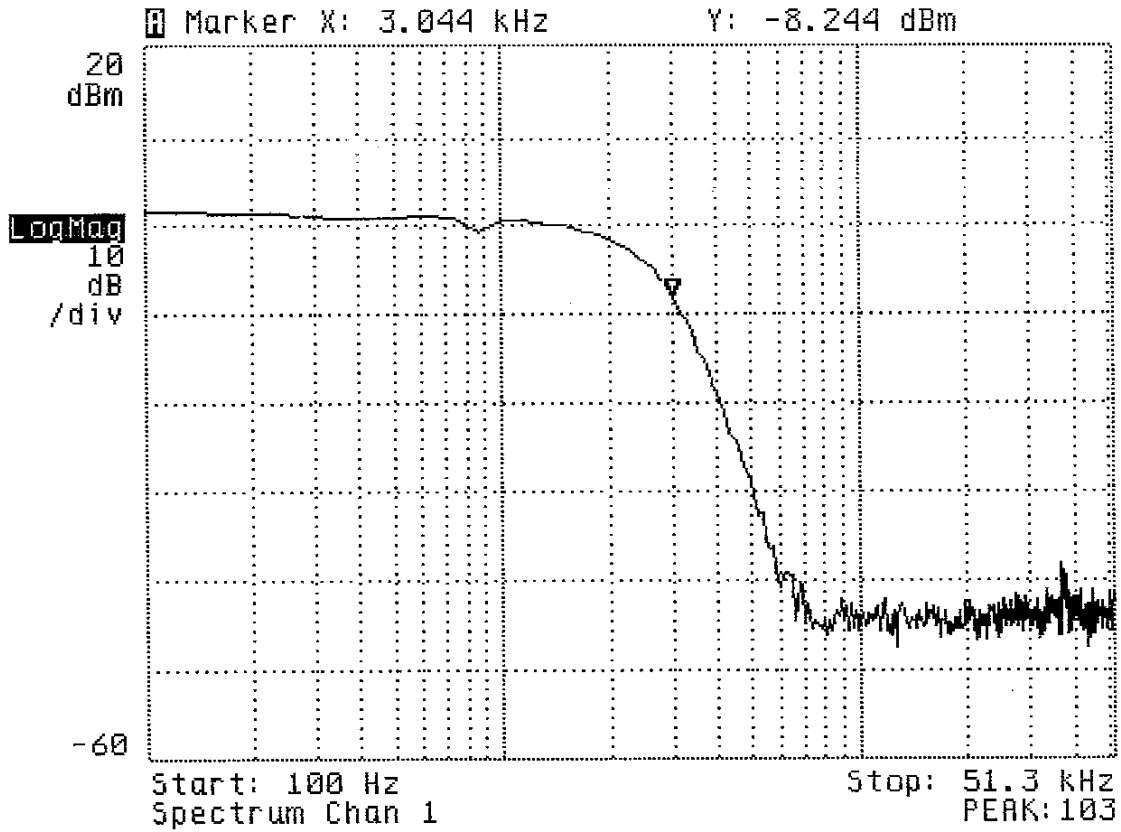

Number: 10
Overlap: 0%

Update Rate: 5

AVERAGE IN PROGRESS

Heas

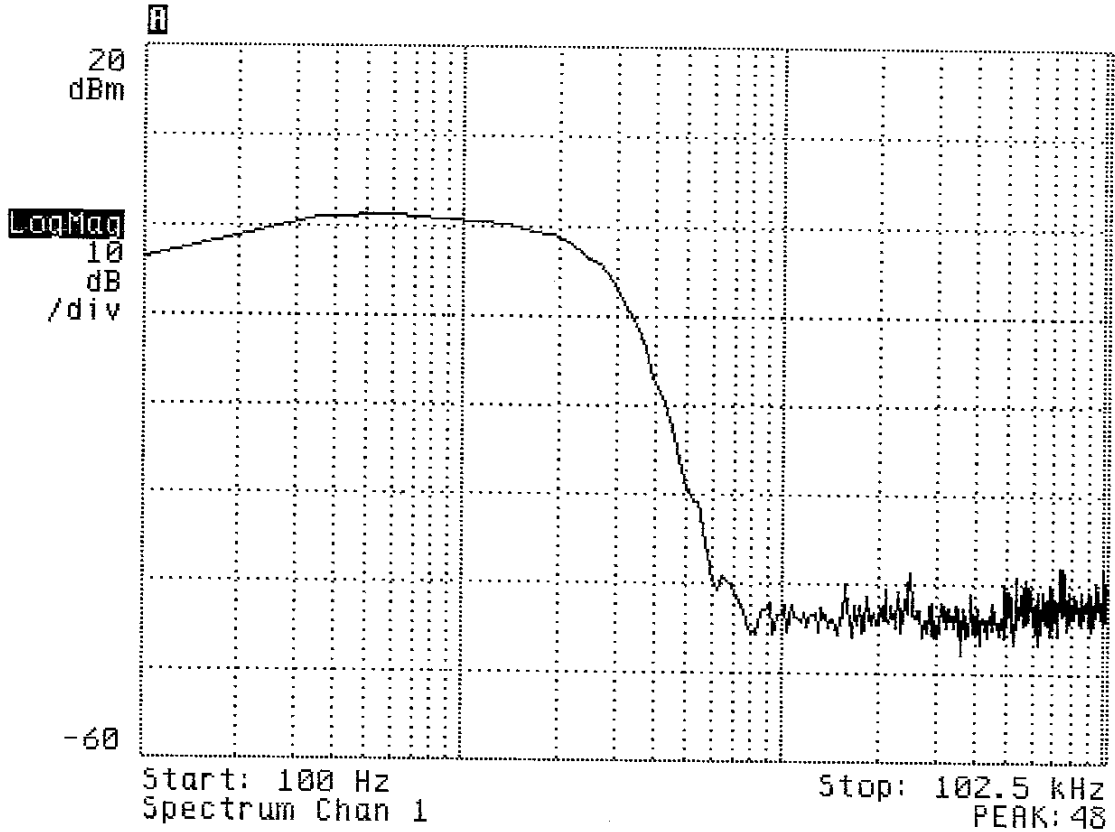

Chart 3.1 Modulation Limiting Measurement Negative

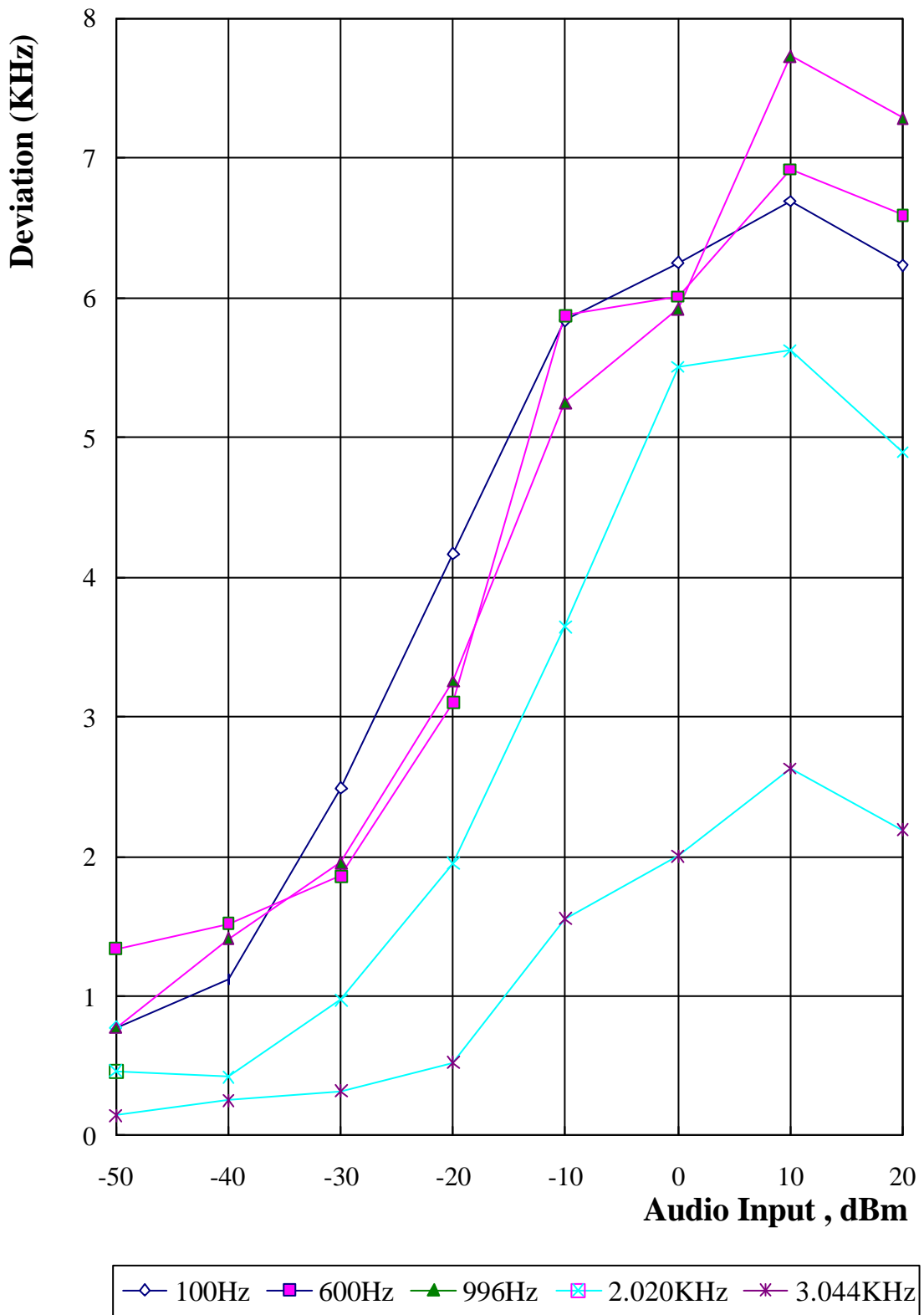
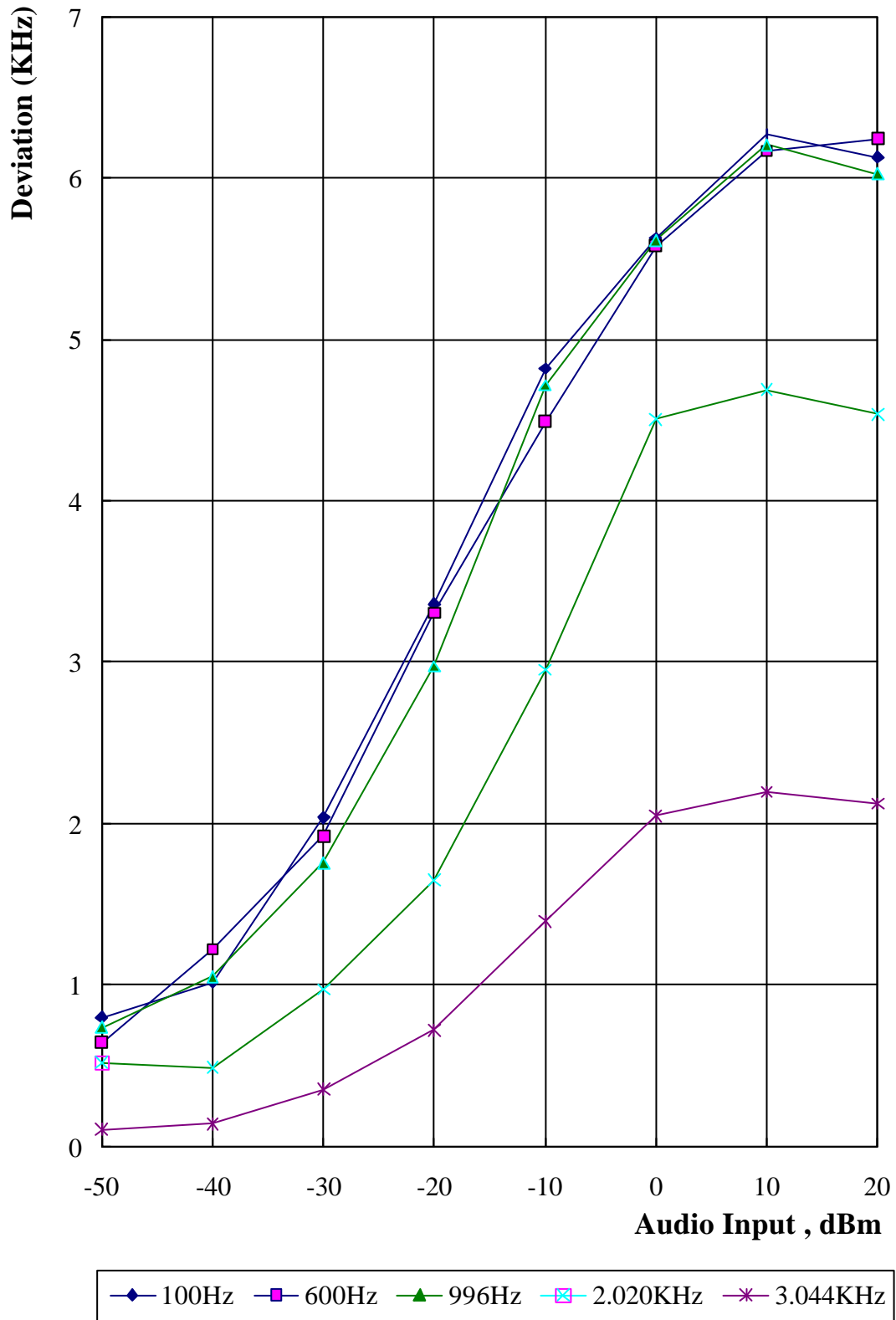

Chart 3.2 Modulation Limiting Measurement Positive



Chapter 4 Occupied Bandwidth Measurement

4.1 Rules and Specification Limits

2.989 .

74.861 (e)(3): Any form of modulation may be used. A maximum deviation of ± 75 KHz is permitted when frequency modulation is employed.

74.861 (e)(5): The operation bandwidth shall not exceed 200 KHz.

4.2 Test Configuration & List of Test Instruments

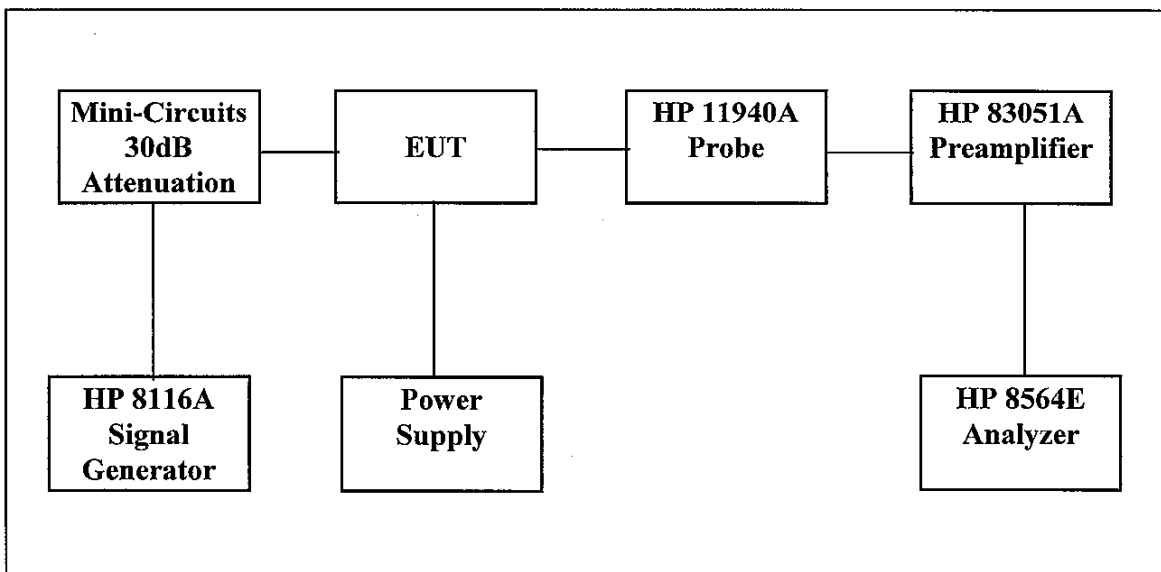

List of test Instrument :

<u>Instrument Name</u>	<u>Model No.</u>	<u>Brand</u>	<u>Serial No.</u>
Spectrum analyzer (9K ~ 40G Hz)	8564E	HP	
Preamplifier (45M ~ 50G Hz)	83051A	HP	VS36433002
Close-Field Probe 30M ~ 1G Hz	11940A	HP	---

4.3 Measurement Procedure

1. Connect the EUT as Section 4.2 .
2. Plot the unmodulated chart shows on spectrum.
3. Set the output of the signal generator to 100Hz, 600Hz, 996Hz, 2.020KHz and 3.044KHz. Increase the amplitude of the signal, while monitoring the modulation meter. Until modulation is max. Measure the bandwidth under 26 dB compared to the unmodulated fundamental carrier peak level of the modulated signal displayed on the spectrum analyzer.
4. The occupied Bandwidth was measured as follow pages.

4.4 Measurement Result

The occupied bandwidth's plot is presented on following pager which illustrates compliance with the rules.

Calculation of Necessary Bandwidth (Bn)

$$B_n = 2M + 2D$$

$$M = \text{Max. Modulation Frequency} = 3.044 \text{ KHz}$$

$$D = \text{Peak Frequency Deviation} = 7.732 \text{ KHz (Chart 3-1)}$$

$$K = 1$$

$$B_n = 21.552 \text{ KHz}$$

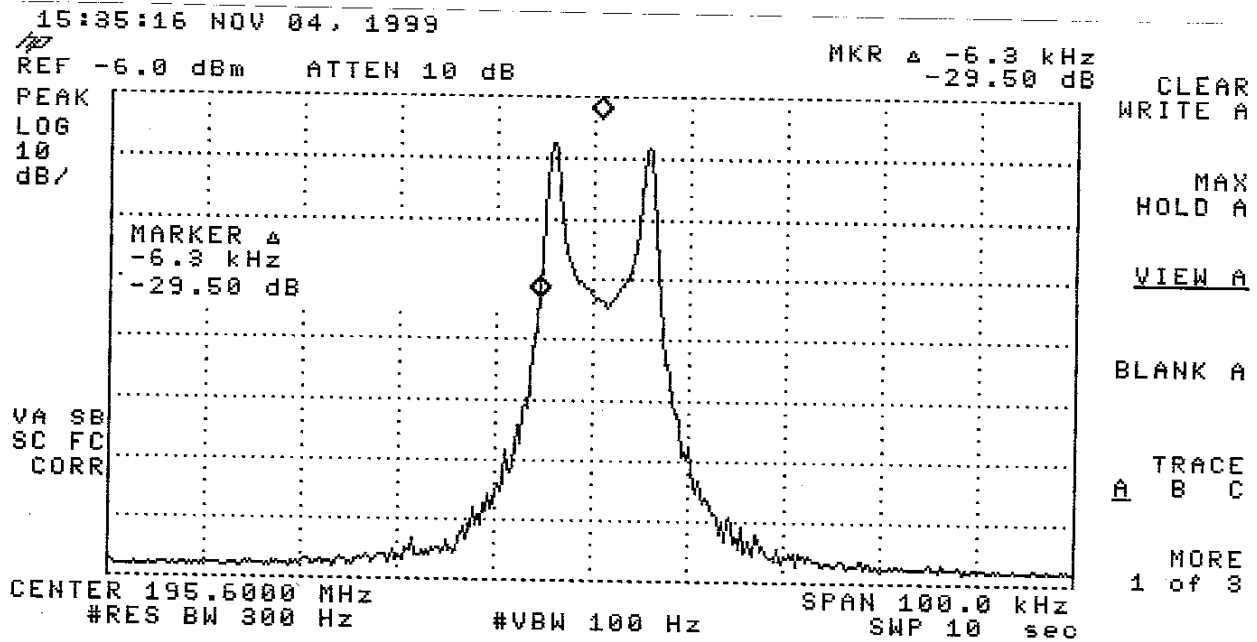

Modulation 100Hz

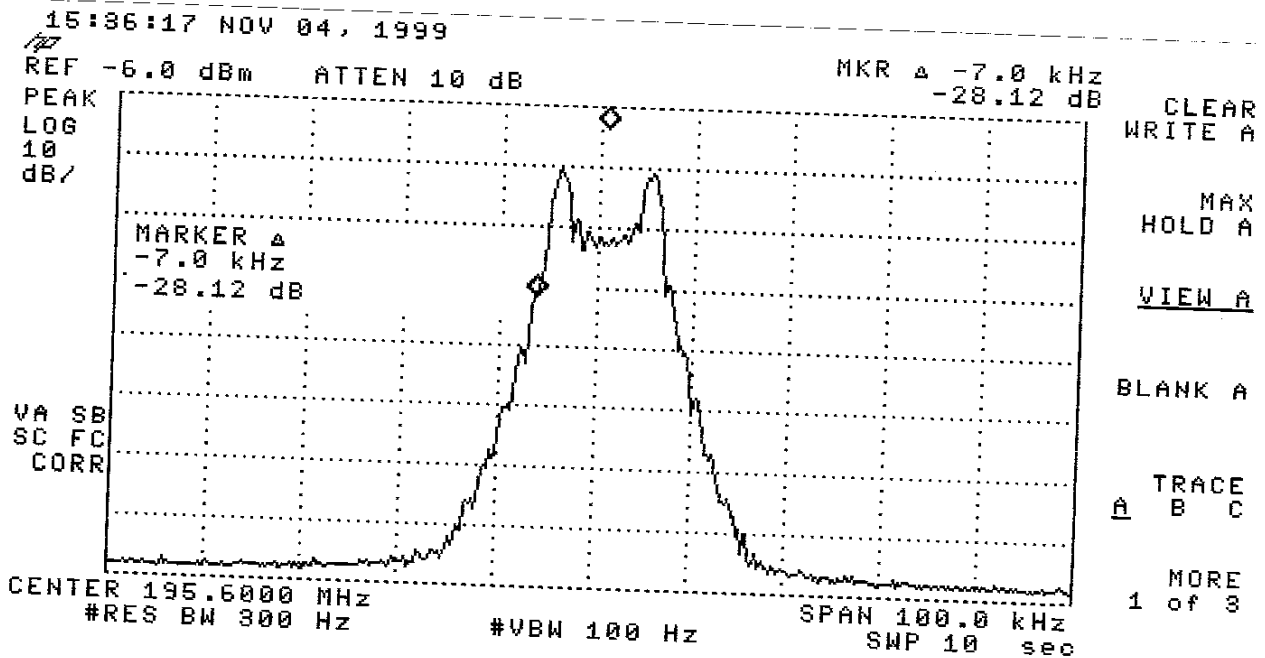

Modulation 600Hz

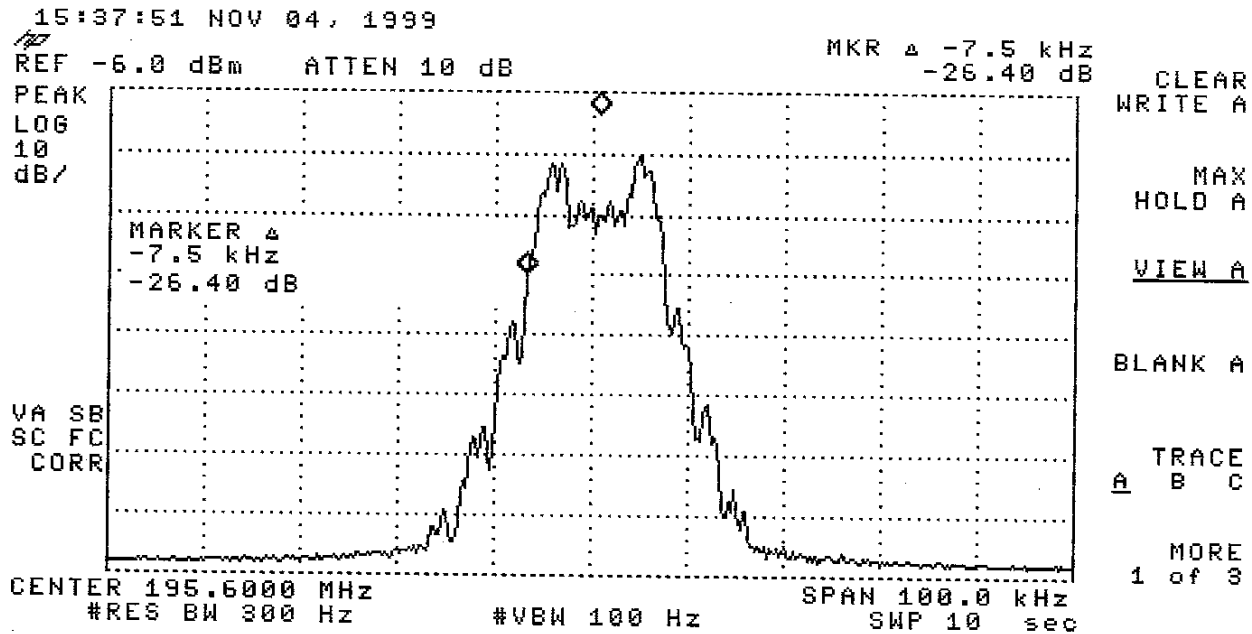

Modulation 996Hz

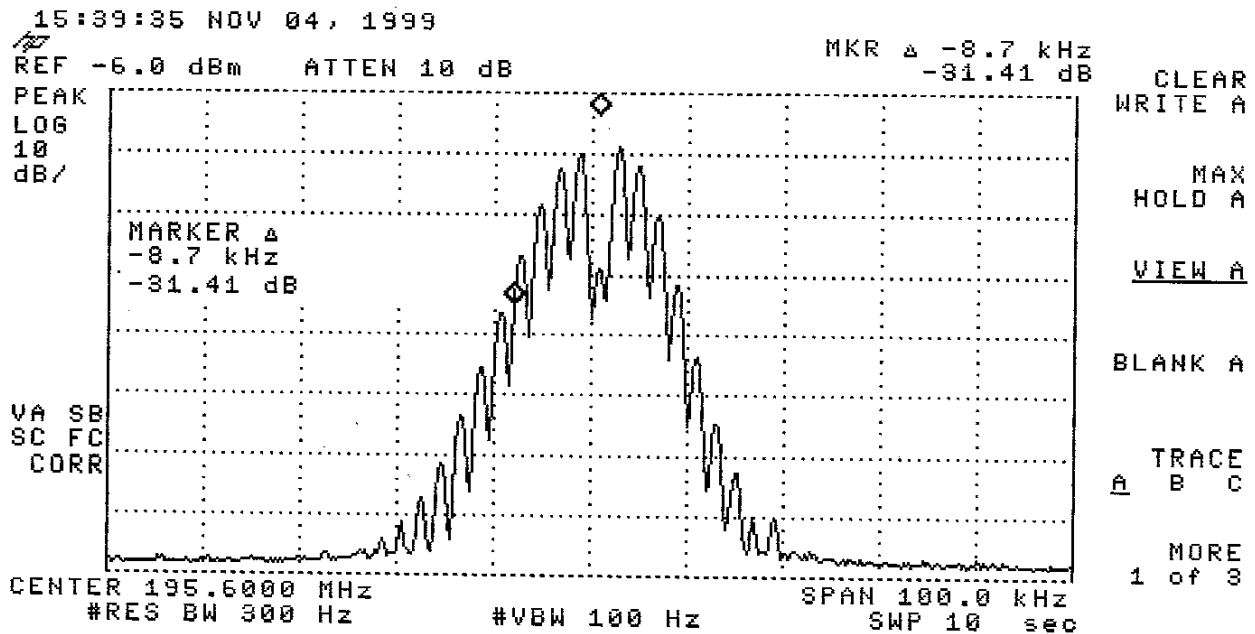

Modulation 2.020KHz

Chapter 5 Field Strength of Spurious Radiation Measurement

5.1 Rules and Specification Limits

2.993 (a) : Measurements shall be made to detect spurious emissions that may be radiated directly from the cabinet, control circuits, Power leads, or intermediate circuit elements under normal conditions of installation and operation.

74.861(e)(b)(iii) : Spurious and harmonics must be at least $43 + 10 \log (\text{Output Power})$ below the Carrier peak

2.997 : In all measurements set forth , the spectrum should be investigated from the lowest radio frequency generated in the equipment up to at least the 10th harmonic of the carrier frequency.

5.2 Measurement Condition & Setup

Pretest : Prior to the final test (OATS test) ,the EUT is placed in a shielded enclosure ,GTEM, and scan from 30MHz to 1GHz.This is done to ensure the radiation exactly emits form the EUT.

Final test : Final radiation measurements is made on a **3 - meter**, open-field test site. The EUT is placed on a nonconductive table, which is 0.8m height, the top surface is 1.0 x 1.5 meter. All the placement is according to ANSI C63.4 - 1992.

The spectrum is examined from 30 MHz to 18 GHz measured by HP spectrum.

The EMCO whole range Antenna is used to measure frequency from 30 MHz to 18 GHz. The final test is used the spectrum HP 8591A & HP 8564E.

Measure more than six top marked frequencies generated form pretest by computer step by step at each frequency. The EUT is rotated 360 degrees, and antenna is raised and lowered from 1 to 4 meter to find the maximum emission levels. The antenna is used with both horizontal and vertical polarization.

Appropriated preamplifier which is made by TRC is used for improving sensitivity and precautions is taken to avoid overloading .The spectrum analyzer's 6dB bandwidth is set to 120 K Hz , and the EUT is measured at quasi-peak mode.

If the emission is close to the frequency band of ambient, the data will be rechecked by the tester and the corrected data will be written in the test data sheet. If the emission is just within the ambient, the data from GTEM will be taken as the final data.

The actual field intensity in decibels referenced to 1 microvolt per meter (dB μ V/m) is determined by algebraically adding the measured reading in dB μ V, the antenna factor (dB) and cable loss (dB) at the appropriate frequency .

$$FI_a \text{ (dB}\mu\text{V/m)} = FI_r \text{ (dB}\mu\text{V)} + AF \text{ (dB)} + CL \text{ (dB)}$$

- FI_a : Actual Field Intensity
- FI_r : Reading of the Field Intensity
- AF : Antenna Factor
- CL : Cable Loss

5.3 List of Measurement Instruments

Instrument Name	Model No.	Brand	Serial No.	Calibration Date	
				Last time	Next time
Spectrum analyzer	8568B	H P	3004A18617	05/15/99	05/15/00
Quasi-peak Adapter	85650A	H P	2521A00984	05/15/99	05/15/00
RF Pre-selector	85685A	H P	2947A01011	05/15/99	05/15/00
Spectrum analyzer	8591A	H P	2919A00263	01/07/99	01/07/00
Spectrum analyzer	8564E	H P	US36433002	08/09/99	08/09/00
Antenna (30M-2G Hz)	3142	EMCO	1296	06/10/99	06/10/00
Antenna (1G-18G Hz)	3142	EMCO	5178	08/09/99	08/09/00
Open test side (Antenna, Amplify, cable calibrated together)				05/15/99	05/15/00

The level of confidence of 95%, the uncertainty of measurement of radiated emission is ± 4.96 dB.

5.4 Measurement Configuration

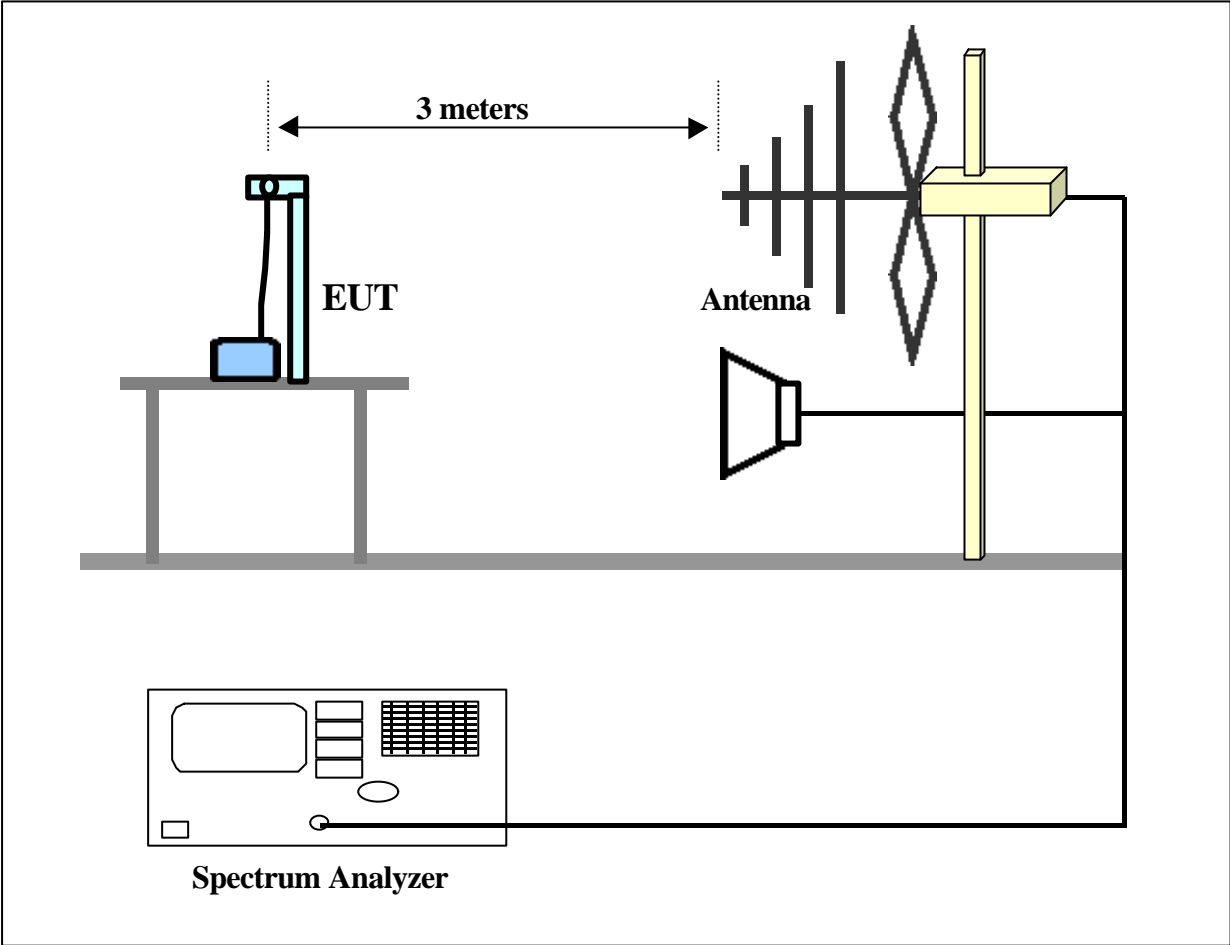

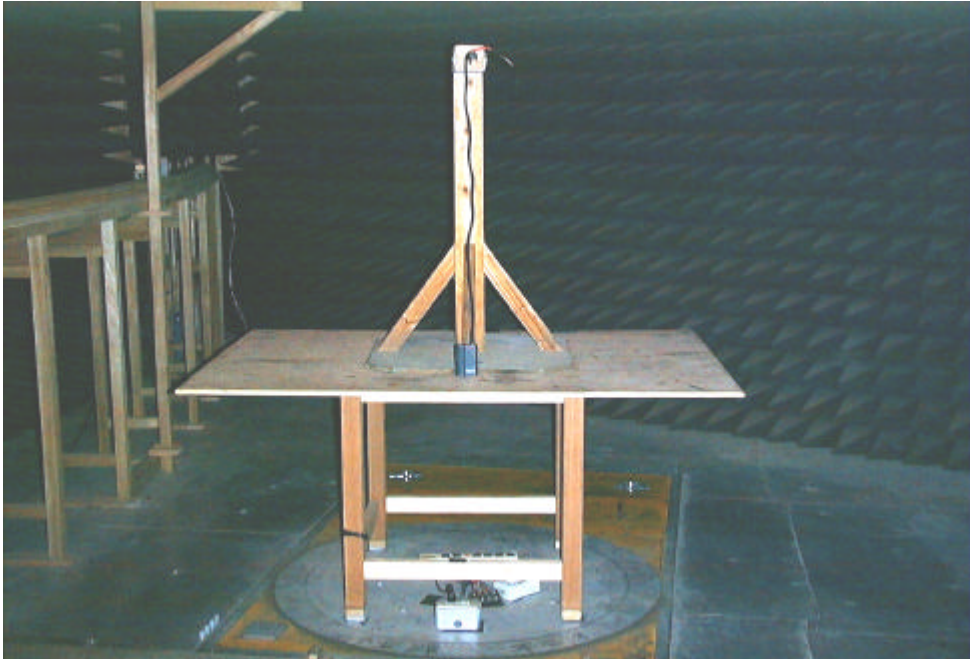

Pic 1 Front View of Test Configuration

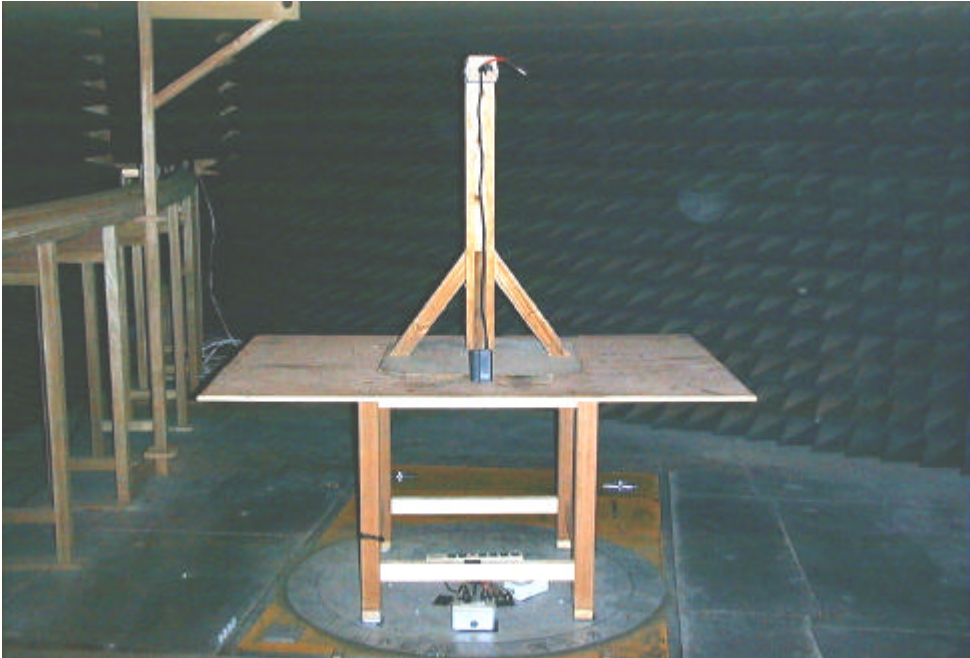

Pic 2 Rear View of the Test Configuration

5.5 Measurement Result:

(Test Frequency: 174.600MHz , Horizontal , 30 MHz ~ 1 GHz)

Test Conditions:

Testing room : Temperature : 26 °C Humidity : 73 % RH
 Testing site : Temperature : 31 °C Humidity : 75 % RH

<i>Frequency</i>	<i>Reading Amplitude</i>	<i>Ant. Height</i>	<i>Table</i>	<i>Correction Factors</i>	<i>Corrected Amplitude</i>	<i>Limit</i>	<i>Margin</i>
MHz	dBμV	m	degree	dB/m	dBμV/m	dBμV/m	dB

159.427	-5.53	1.00	65	-14.30	8.77	84.38	-75.61
211.210	-1.23	1.94	23	-14.19	12.96	84.38	-71.42
220.800	3.89	1.94	68	-15.46	19.35	84.38	-65.03
247.018	-5.44	1.94	54	-15.40	9.96	84.38	-74.42
334.320	-6.01	1.94	1	-17.37	11.36	84.38	-73.02

Note:

1. Margin = Amplitude - limit, *if margin is minus means under limit.*
2. Corrected Amplitude = Reading Amplitude - Correction Factors
3. Correction factor = Antenna factor + (Cable Loss - Amplitude gain)
 (For example : 30MHz correction factor = 15.5 + (-15.26) = 0.24 dB/m)
4. Attenuation required = 43 + 10 log (0.00002 mW) = -33.93
 Limit = 50.45 - (-33.93) = 84.38

Measurement Result:

(Test Frequency: 174.600MHz , Horizontal , 1 GHz ~ 18 GHz)

Radiated Emission				Correction Factors (dB)	Corrected Amplitude (dBμV/m)	FCC Class B (3 m)	
Frequency (GHz)	Amplitude (dBμV/m)	Ant. H. (cm)	Table (°)			Limit (dBμV/m)	Margin (dB)
1.423	35.30	100.00	93	-8.67	26.63	54.00	-27.37
1.510	38.46	100.00	100	-8.67	29.79	54.00	-24.21
1.590	41.63	100.00	212	-8.67	32.96	54.00	-21.04
1.663	38.63	100.00	56	-8.67	29.96	54.00	-24.04

Note:

1. Margin = Corrected - Limit.
2. Peak Amplitude + Correction Factor = Corrected

Radiated Emission Test Result:

(Test Frequency: 174.600MHz , Vertical , 30 MHz ~ 1 GHz)

<i>Frequency</i>	<i>Reading Amplitude</i>	<i>Ant. Height</i>	<i>Table</i>	<i>Correction Factors</i>	<i>Corrected Amplitude</i>	<i>Limit</i>	<i>Margin</i>
MHz	dBμV	m	degree	dB/m	dBμV/m	dBμV/m	dB

159.560	-1.48	1.95	28	-13.42	11.94	84.38	-72.44
246.990	-5.39	1.95	2	-15.42	10.03	84.38	-74.35
254.460	8.21	2.93	0	-15.87	24.08	84.38	-60.30
334.380	10.46	1.95	0	-17.23	27.69	84.38	-56.69
501.640	-3.64	1.00	80	-21.86	18.22	84.38	-66.16

Radiated Emission Test Result:

(Test Frequency: 174.600MHz , Vertical , 1 GHz ~ 18 GHz)

<i>Radiated Emission</i>				<i>Correction Factors</i>	<i>Corrected Amplitude</i> (dB μ V/m)	<i>FCC Class B (3 m)</i>	
<i>Frequency</i> (GHz)	<i>Amplitude</i> (dB μ V/m)	<i>Ant. H.</i> (cm)	<i>Table</i> ($^{\circ}$)	(dB)		<i>Limit</i> (dB μ V/m)	<i>Margin</i> (dB)
1.423	35.30	100.00	203	-8.67	26.63	54.00	-27.37
1.510	35.30	100.00	107	-8.67	26.63	54.00	-27.37
1.590	37.13	100.00	281	-8.67	28.46	54.00	-25.54

Measurement Result:

(Test Frequency: 195.600MHz , Horizontal , 30 MHz ~ 1 GHz)

Frequency	Reading Amplitude	Ant. Height	Table	Correction Factors	Corrected Amplitude	Limit	Margin
MHz	dBμV	m	degree	dB/m	dBμV/m	dBμV/m	dB

97.800	12.44	3.95	92	-12.18	24.62	84.38	-59.76
147.710	-5.08	3.95	0	-14.62	9.54	84.38	-74.84
211.210	1.67	1.00	10	-14.19	15.86	84.38	-68.52
244.752	-5.37	1.93	12	-15.33	9.96	84.38	-74.42
293.827	-5.89	1.93	49	-15.92	10.03	84.38	-74.35

Note:

1. Margin = Amplitude - limit, *if margin is minus means under limit.*
2. Corrected Amplitude = Reading Amplitude - Correction Factors
3. Correction factor = Antenna factor + (Cable Loss - Amplitude gain)
 (For example : 30MHz correction factor = 15.5 + (-15.26) = 0.24 dB/m)
4. Attenuation required = 43 + 10 log (0.00049 mW) = -20.07
 Limit = 64.31 - (-20.07) = 84.38

Measurement Result:

(Test Frequency: 195.600MHz , Horizontal , 1 GHz ~ 18 GHz)

<i>Radiated Emission</i>				<i>Correction Factors</i>	<i>Corrected Amplitude</i> (dBμV/m)	<i>FCC Class B (3 m)</i>	
<i>Frequency</i> (GHz)	<i>Amplitude</i> (dBμV/m)	<i>Ant. H.</i> (cm)	<i>Table</i> (°)	(dB)		<i>Limit</i> (dBμV/m)	<i>Margin</i> (dB)

Radiated Emission Test Result:
 (Test Frequency: 195.600MHz , Vertical , 30 MHz ~ 1 GHz)

<i>Frequency</i>	<i>Reading Amplitude</i>	<i>Ant. Height</i>	<i>Table</i>	<i>Correction Factors</i>	<i>Corrected Amplitude</i>	<i>Limit</i>	<i>Margin</i>
MHz	dBμV	m	degree	dB/m	dBμV/m	dBμV/m	dB

97.790	26.60	1.00	69	-11.31	37.91	84.38	-46.47
146.700	13.87	1.94	74	-13.91	27.78	84.38	-56.60
211.210	1.35	1.94	35	-14.33	15.68	84.38	-68.70
244.510	2.77	2.93	131	-15.29	18.06	84.38	-66.32
293.400	-1.45	1.00	60	-16.81	15.36	84.38	-69.02

Radiated Emission Test Result:

(Test Frequency: 195.600MHz , Vertical , 1 GHz ~ 18 GHz)

<i>Radiated Emission</i>				<i>Correction Factors</i>	<i>Corrected Amplitude</i> (dBμV/m)	<i>FCC Class B (3 m)</i>	
<i>Frequency</i> (GHz)	<i>Amplitude</i> (dBμV/m)	<i>Ant. H.</i> (cm)	<i>Table</i> (°)	(dB)		<i>Limit</i> (dBμV/m)	<i>Margin</i> (dB)

Measurement Result:

(Test Frequency: 215.600MHz , Horizontal , 30 MHz ~ 1 GHz)

Frequency	Reading Amplitude	Ant. Height	Table	Correction Factors	Corrected Amplitude	Limit	Margin
MHz	dBμV	m	degree	dB/m	dBμV/m	dBμV/m	dB

85.660	-4.63	2.93	78	-10.81	6.18	84.38	-78.20
107.780	11.77	1.93	104	-13.18	24.95	84.38	-59.43
161.680	2.95	2.93	59	-14.15	17.10	84.38	-67.28
323.390	9.02	1.00	26	-17.21	26.23	84.38	-58.15
780.900	-5.42	1.00	149	-26.25	20.83	84.38	-63.55

Note:

1. Margin = Amplitude - limit, *if margin is minus means under limit.*
2. Corrected Amplitude = Reading Amplitude - Correction Factors
3. Correction factor = Antenna factor + (Cable Loss - Amplitude gain)
 (For example : 30MHz correction factor = 15.5 + (-15.26) = 0.24 dB/m)
4. Attenuation required = $43 + 10 \log (0.028528 \text{ mW}) = -2.45$
 Limit = $81.93 - (-2.45) = 84.38$

Measurement Result:

(Test Frequency: 215.600MHz , Horizontal , 1 GHz ~ 18 GHz)

<i>Radiated Emission</i>				<i>Correction Factors</i>	<i>Corrected Amplitude</i> (dBμV/m)	<i>FCC Class B (3 m)</i>	
<i>Frequency</i> (GHz)	<i>Amplitude</i> (dBμV/m)	<i>Ant. H.</i> (cm)	<i>Table</i> (°)	(dB)		<i>Limit</i> (dBμV/m)	<i>Margin</i> (dB)

Radiated Emission Test Result:

(Test Frequency: 215.600MHz , Vertical , 30 MHz ~ 1 GHz)

<i>Frequency</i>	<i>Reading Amplitude</i>	<i>Ant. Height</i>	<i>Table</i>	<i>Correction Factors</i>	<i>Corrected Amplitude</i>	<i>Limit</i>	<i>Margin</i>
MHz	dBμV	m	degree	dB/m	dBμV/m	dBμV/m	dB

107.790	24.46	1.00	77	-12.13	36.59	84.38	-47.79
161.690	20.03	1.94	37	-13.31	33.34	84.38	-51.04
323.380	18.22	1.94	66	-17.64	35.86	84.38	-48.52
431.190	0.97	1.00	138	-19.92	20.89	84.38	-63.49
488.882	-5.39	2.93	75	-21.67	16.28	84.38	-68.10

Radiated Emission Test Result:

(Test Frequency: 215.600MHz , Vertical , 1 GHz ~ 18 GHz)

<i>Radiated Emission</i>				<i>Correction Factors</i>	<i>Corrected Amplitude</i> (dB μ V/m)	<i>FCC Class B (3 m)</i>	
<i>Frequency</i> (GHz)	<i>Amplitude</i> (dB μ V/m)	<i>Ant. H.</i> (cm)	<i>Table</i> (°)	(dB)		<i>Limit</i> (dB μ V/m)	<i>Margin</i> (dB)

Chapter 6 Frequency Stability Tolerance Measurement

6.1 Rules and Specification Limits

2.995

74.861(e)(4): The frequency tolerance of the transmitter shall be 0.005 percent.

6.2 Measurement Condition & Setup with Temperature Variation

1. Place the EUT in the chamber, powered in its normal operation.
2. Set the temperature of the chamber -30 degree Centigrade. Allow the equipment to stabilize at that temperature.
3. Measured the carrier frequency using preamplifier and frequency counter.
4. Repeated procedures 1 to 3 from -20 to 50 degree Centigrade at intervals of 10 degree.

6.3 List of Measurement Instruments with Temperature Variation List of test Instrument :

<u>Instrument Name</u>	<u>Model No.</u>	<u>Brand</u>	<u>Remark</u>
Spectrum Analyzer	8591A	H P	1.8GHz
Temperature Chamber	THS-MV2	King Son	
Near field Probe	7405-901	EMCO	
Power Supply			
Auto Transformer	Powerstat	Supprior Elec. Co.	

6.4 Measurement Configuration of Temperature Variation Test:

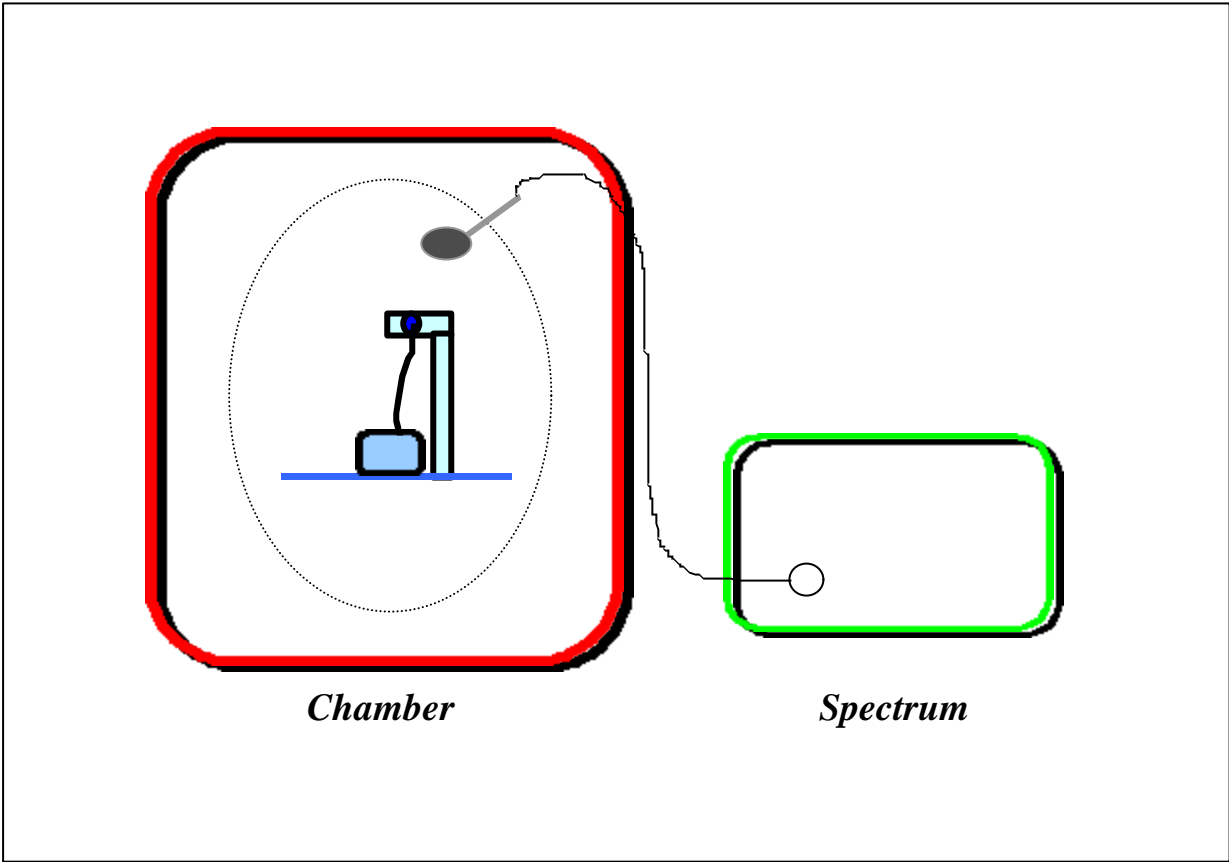

6.5 Measurement Result with Temperature Variation

A plot and table is presented which illustrates compliance with the rule where the center frequency is 195.600 MHz.

Temperature Variation Table

<i>Temperature (Centigrade)</i>	<i>Frequency (MHz)</i>	<i>Tolerance (MHz)</i>
-30	195.608364	195.590220 ~ 195.609780
-20	195.606480	195.590220 ~ 195.609780
-10	195.604733	195.590220 ~ 195.609780
0	195.601889	195.590220 ~ 195.609780
10	195.599459	195.590220 ~ 195.609780
20	195.598684	195.590220 ~ 195.609780
30	195.600109	195.590220 ~ 195.609780
40	195.599876	195.590220 ~ 195.609780
50	195.598180	195.590220 ~ 195.609780

Temperature Variation Vs. Frequency Chart

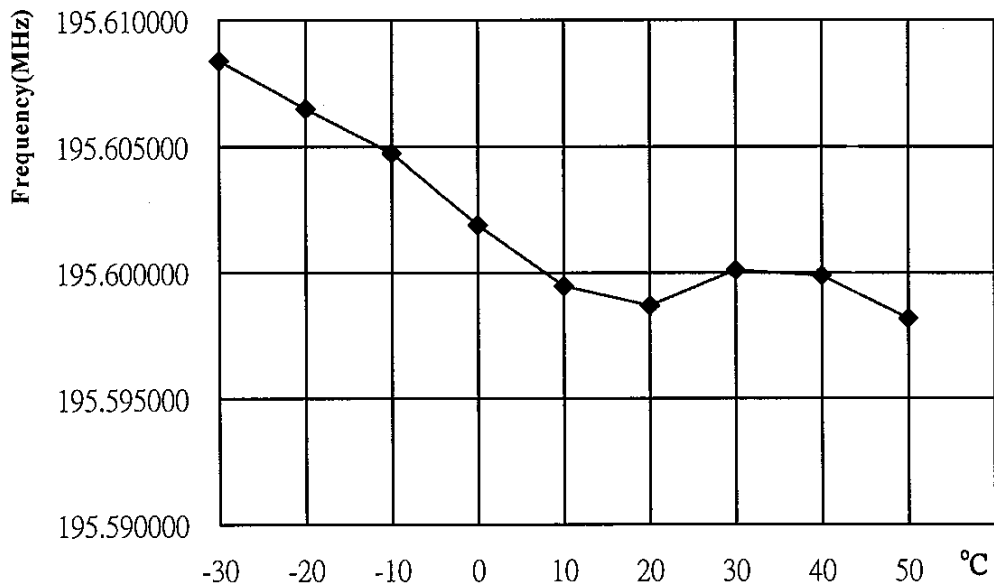

6.6 Measurement Condition & Setup with Voltage Variation

1. Attached the power line of the power supply to the battery position of the EUT.
2. Tuned the output power level to battery end point, 85 %, 100%, 115% of the normal operation power of EUT.
3. Recorded the frequency with a frequency counter.

6.7 List of Test Instrument :

<u>Instrument Name</u>	<u>Model No.</u>	<u>Brand</u>	<u>Remark</u>
Spectrum Analyzer	8591A	H P	1.8GHz
Temperature Chamber	THS-MV2	King Son	
Near field Probe	7405-901	EMCO	
Power Supply			
Auto Transformer	Powerstat	Supprior Elec. Co.	

6.8 Configuration of Voltage Variation Test :

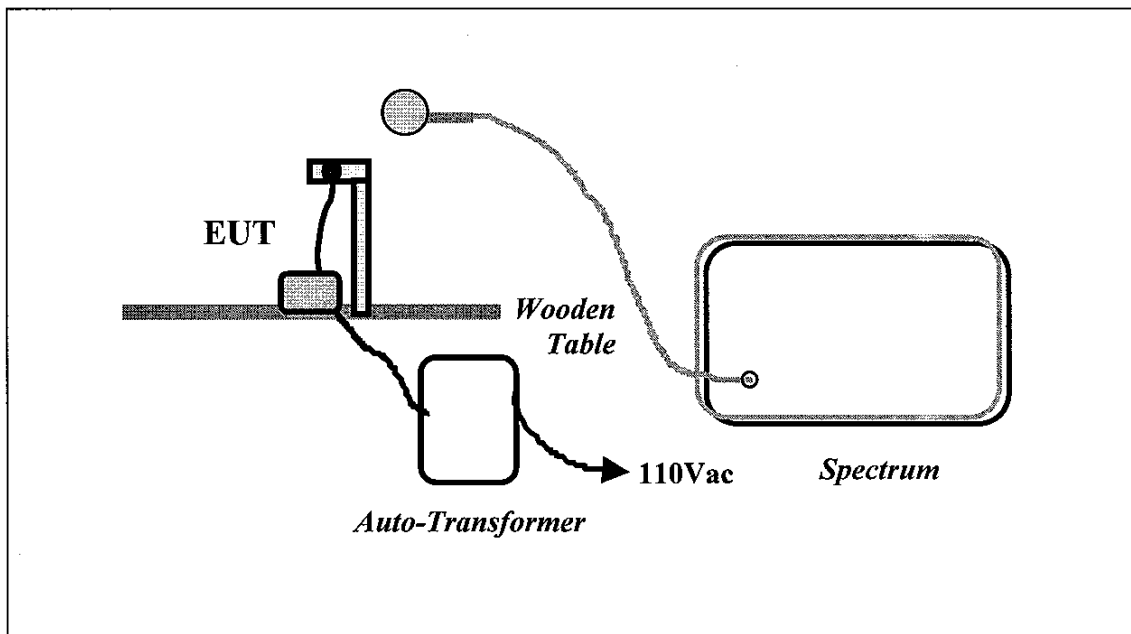

6.9 Measurement Result with Voltage Variation

Frequency Stability of Voltage Variation Measurement Table

<i>Supply Voltage (Volt)</i>	<i>Frequency (MHz)</i>	<i>Tolerance (MHz)</i>
7.65 (85%)	195.599642	195.590220 ~ 195.609780
9.00 (100%)	195.600203	195.590220 ~ 195.609780
10.35 (115%)	195.600246	195.590220 ~ 195.609780
Endpoint-Voltage : 6.50 V		

Voltage Variation Vs. Frequency Chart

