

USER'S MANUAL

2.4GHz Digital
WIRELESS MICROPHONE SYSTEM

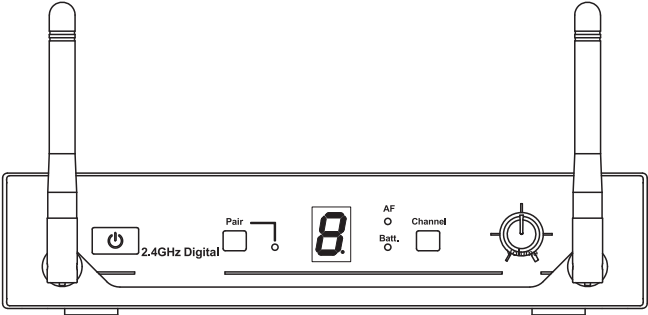
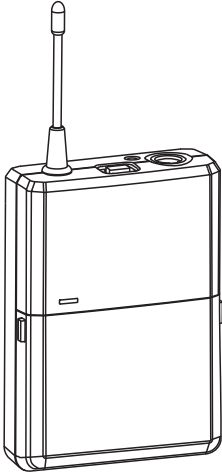
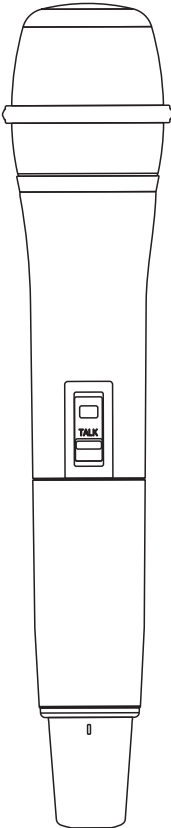

Contents:

Introduction	1
Quick Start Guide	2
Product Description	4
System Operation	7
Color Label Identification	12
Trouble Shooting	13
Specification	14

● Introduction

Thank you for purchasing our product. This wireless microphone system operates in 2.4GHz frequency with 8 selectable channels. Please read this instruction manual carefully before operating the system. This manual covers the function and operation of the wireless microphone system.

● Federal Communication Commission Interference Statement

This equipment has been tested and found to comply with the limits for a Class B digital device, pursuant to Part 15 of the FCC Rules. These limits are designed to provide reasonable protection against harmful interference in a residential installation. This equipment generates, uses and can radiate radio frequency energy and, if not installed and used in accordance with the instructions, may cause harmful interference to radio communications. However, there is no guarantee that interference will not occur in a particular installation. If this equipment does cause harmful interference to radio or television reception, which can be determined by turning the equipment off and on, the user is encouraged to try to correct the interference by one of the following measures:

- . Reorient or relocate the receiving antenna.
- . Increase the separation between the equipment and receiver.
- . Connect the equipment into an outlet on a circuit different from that to which the receiver is connected.
- . Consult the dealer or an experienced radio/TV technician for help.

FCC Caution: To assure continued compliance, any changes or modifications not expressly approved by the party responsible for compliance could void the user's authority to operate this equipment. (Example - use only shielded interface cables when connecting to computer or peripheral devices).

FCC Radiation Exposure Statement

This equipment complies with FCC RF radiation exposure limits set forth for an uncontrolled environment. This equipment should be installed and operated with a minimum distance of 0.5 centimeters between the radiator and your body.

This transmitter must not be co-located or operating in conjunction with any other antenna or transmitter.

The antennas used for this transmitter must be installed to provide a separation distance of at least 0.5 cm from all persons and must not be co-located or operating in conjunction with any other antenna or transmitter.

This device complies with Part 15 of the FCC Rules. Operation is subject to the following two conditions: (1) This device may not cause harmful interference, and (2) This device must accept any interference received, including interference that may cause undesired operation.

Quick Start Guide

1. Connected Receiver Power Cable

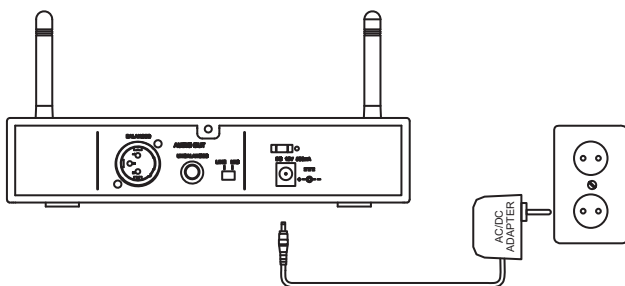

2. Connect Mixer or Amplifier

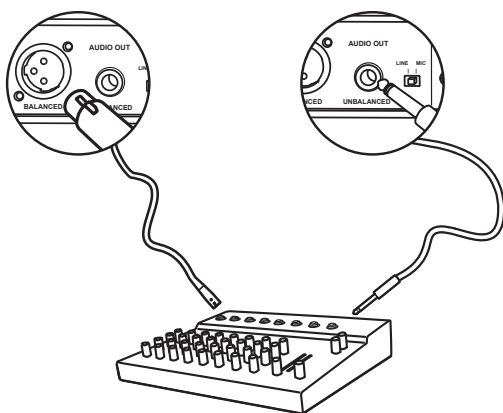

3. Select Channel

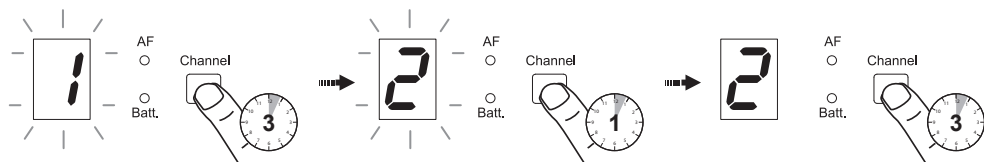

Quick Start Guide

4. Insert Batteries

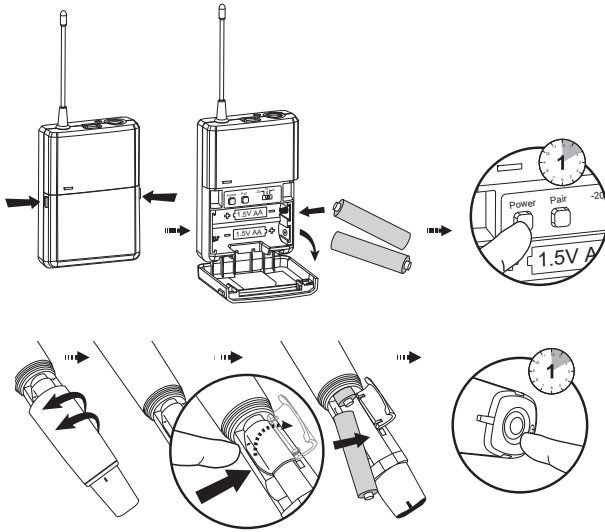

5. SYNC

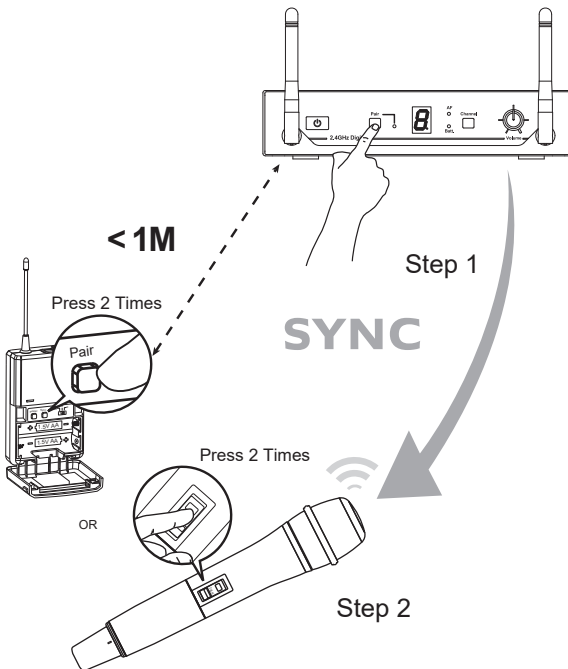

● **Receiver**

Front :

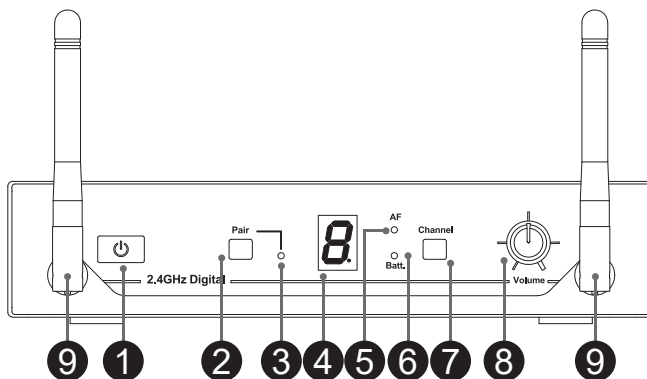

1. Power Button
2. Pair Button: Press the button to activate pair function with transmitter.
3. RF Indicator: The LED lights to indicate that RF signal has been received.
4. LED Display: Display selected channel.
5. AF Indicator: The LED lights to indicate that AF signal has been received.
6. Battery LED: If the Red LED stays flashing, it indicate the batteries on transmitter will out of power soon, and should be changed.
7. Channel Selector: Tap the channel backward.
8. Volume Control: Adjust the receiver output level.
9. Fixed 2.4GHz Antenna

Rear :

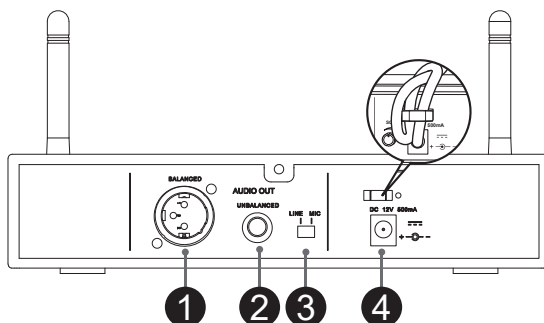

1. Balanced XLR Audio Output
2. Unbalanced 6.3mm Audio Output
3. MIC/LINE Switch: Use this switch to adjust audio output level for MIC level (-20dB) or LINE level (0dB).
4. Power Adapter Connector

● **Handheld Microphone**

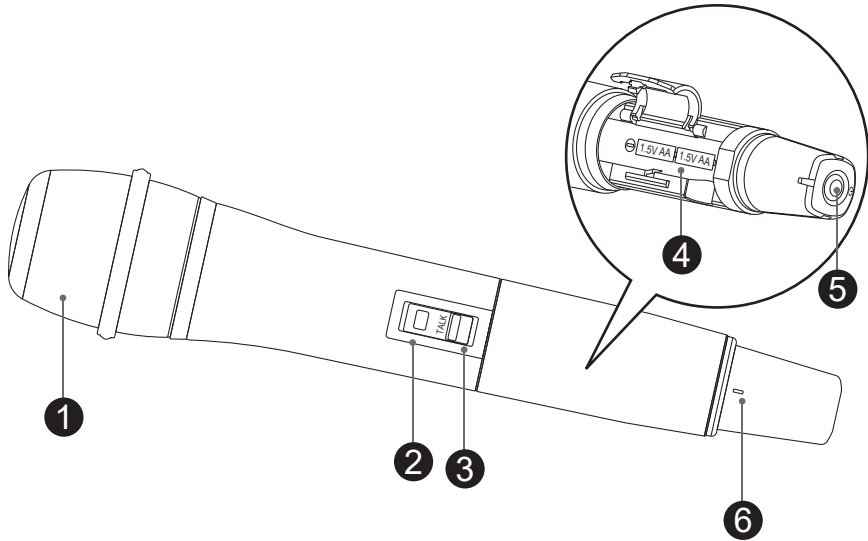

1. Grille: Protects the microphone capsule and helps reduce breath sounds and wind noise.
2. Pair Button: Press the button to activate pair function with receiver.
3. Talk Button: Push the button up to talk. Push the button down for mute.
4. Battery compartment: Insert two AA size batteries into the compartment and make sure that the polarity of batteries is correct.
5. Power Button: Press for 1 second to power microphone on or press for 3 seconds to power microphone off.
6. Power LED: Indicate the power / low battery level status.

LED Indicator	Status
Green	Ready
Flashing Green	The synchronization process is actuated.
Flashing Red	Low battery power when less than 10 minutes operation

● **Bodypack Transmitter**

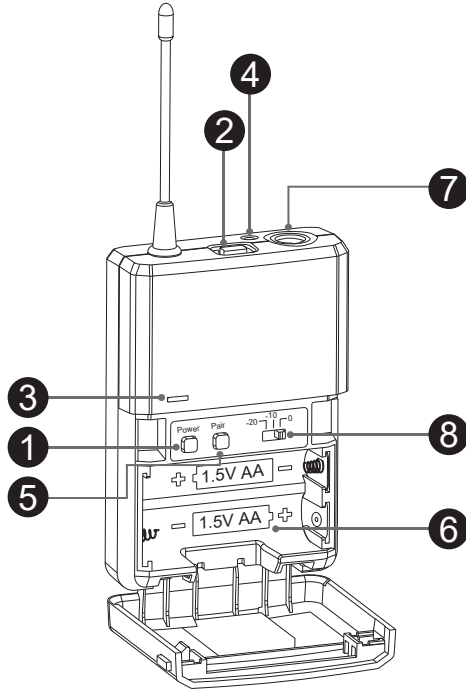

1. Power Button: Press for 1 second to power transmitter on or press for 3 seconds to power transmitter off.
2. Mute Button: With the transmitter on, a slight press for button will toggle between mute and unmute function.
3. Power LED: Indicate the power / low battery level status.

LED Indicator	Status
Green	Ready
Flashing Green	The synchronization process is actuated.
Flashing Red	Low battery power when less than 10 minutes operation

4. MUTE LED: Blue LED light on in mute status.
5. Pair Button: Press the button to activate pair function with receiver.
6. Battery compartment: Insert two AA size batteries into the compartment and make sure that the polarity of batteries is correct.
7. Mini XLR Connector: Connect to the lapel microphone or headset microphone.
8. Gain Switch: The switch sets the audio input to -20dB, -10dB, 0dB.

● Connecting the receiver

Prior to setting up, please check that the transmitter and receiver are tuned to the same channel. Two or more transmitters operating in the same channel can not be used at the same time and area.

1

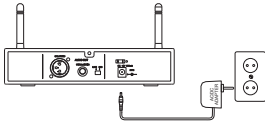

- Connected the provided DC power supply to the receiver power input with an appropriate AC power source. The LED display will light and the receiver is on.

2

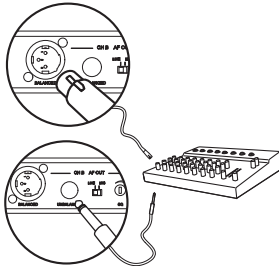

- Using a standard audio cable with 3-pin XLR connectors or 6.3mm phone plugs to connect the mixer or amplifier.
- ✧ Never use the balanced and unbalanced audio outputs at the same time! This may cause signal loss or increased noise.

3

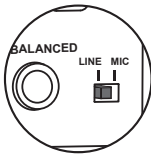

- Set the audio output level for
MIC: -20dB
LINE: 0dB (Default Setting)

4



- Using the Volume Controller to adjust the AF audio level to the input of the amplifier or mixer.
- ✧ Default Setting: In minimum VOLUME position.

● Channel setting on receiver

Notice: Do not put two or more transmitters operating nearby when setting up the channel. Please keep transmitter at least one meter away from receiver.

Setting interference-free channel by manual operation.

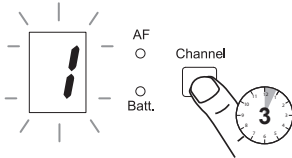

- Press "Channel" button for 3 seconds till LED display is flashing.

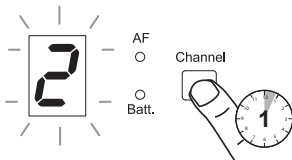

- Slight press "Channel" button to change the channel forward.

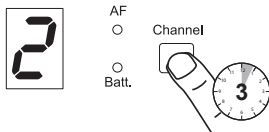

- Press "Channel" button for 3 seconds to lock the setting.
- ✧ If you do not press "Channel" button for 3 seconds to lock the setting, the LED will keep flashing for a while and revert to the last set channel.

- **Set up the handheld microphone / bodypack transmitter**

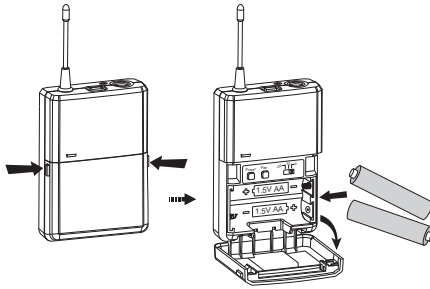

- Open the battery cover and insert batteries into the battery compartment conforming to the polarity (+)(-) marks.

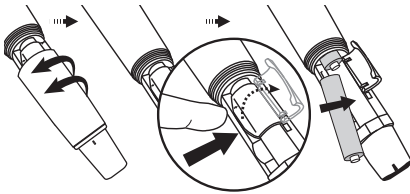

- Unscrew the handheld Mic and open the battery cover to insert the battery into the battery compartment and confirm the marks of the polarity (+) (-).

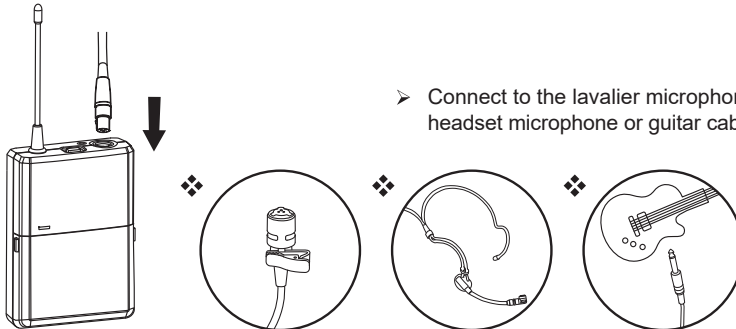

- Connect to the lavalier microphone, headset microphone or guitar cable.

NOTE: When you don't use this device for a long term period, please switch the power "off" in order to save more electricity.

● **Set up the handheld microphone / bodypack transmitter**

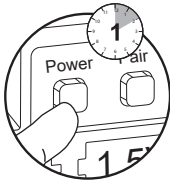

Bodypack

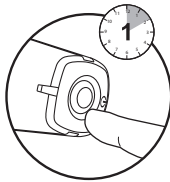

Handheld

- Press for 1 seconds to turn the Handheld/ Bodypack transmitter on.
- ✦ If the LED stays flashing , it indicates that the battery will out of power soon and should be changed.

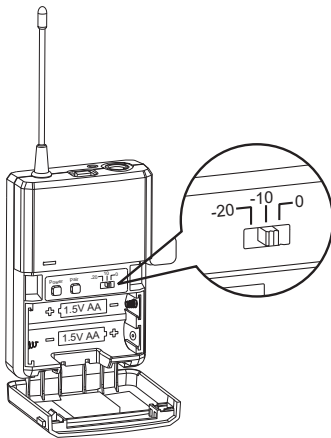

- Adjust the audio input level.
 - 0dB
 - -10dB (Default Setting)
 - -20dB



• 0dB



• -10dB



• -20dB

NOTE: When you don't use this device for a long term period, please switch the power switch to "off" mode to save more electric power.

● Pairing a transmitter with a receiver

Automatic frequency synchronization via remote channel for easy setup.

- First, switch the transmitter and the receiver on.
Press the Pair button on the front panel of receiver.
The Pair LED flashes on the receiver.

Then, press 2 times on the Pair button of the transmitter to set the selected channel automatically.

- When using Pair button setting, the distance of receiver and transmitter is within 1 M.

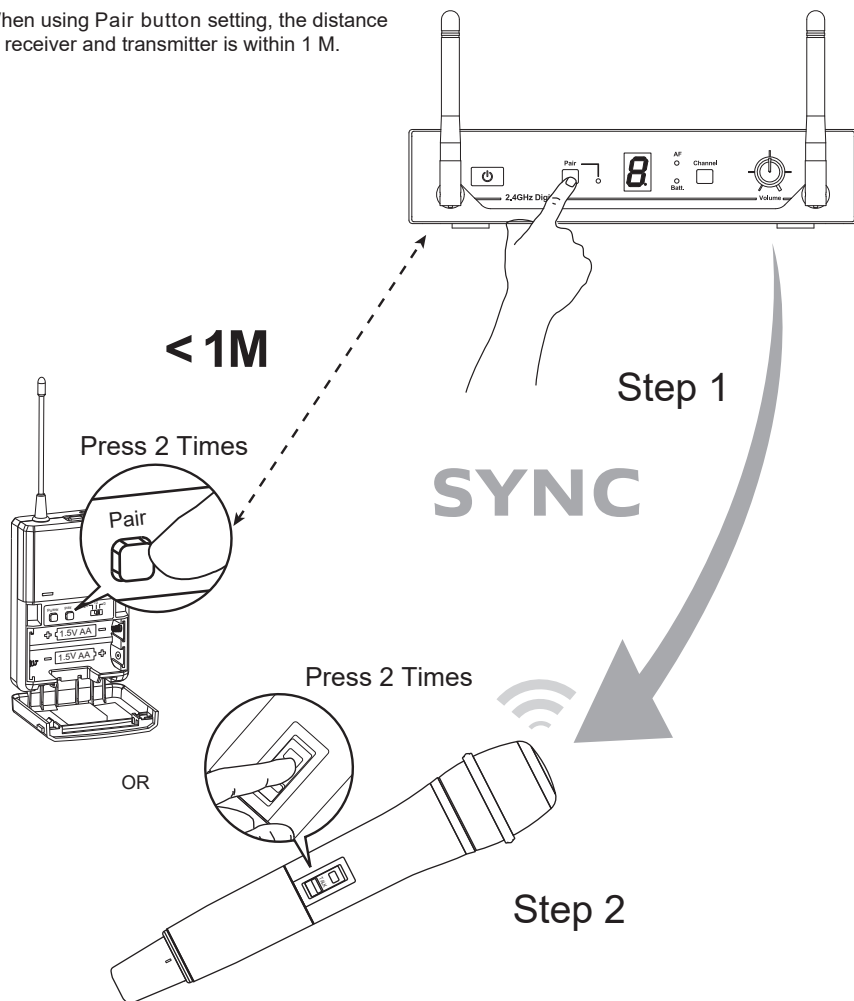

● **Color Label Identification**

You can also stick the color label on the receiver and transmitter for quickly identify the pair system.

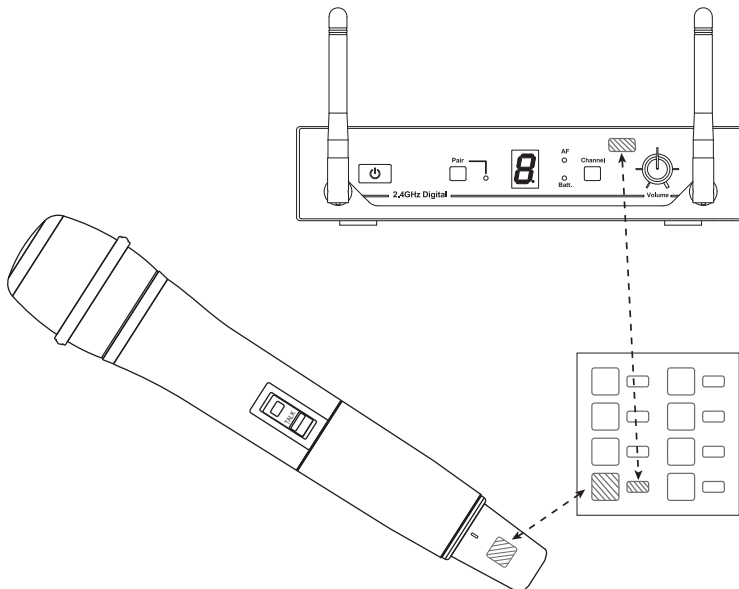
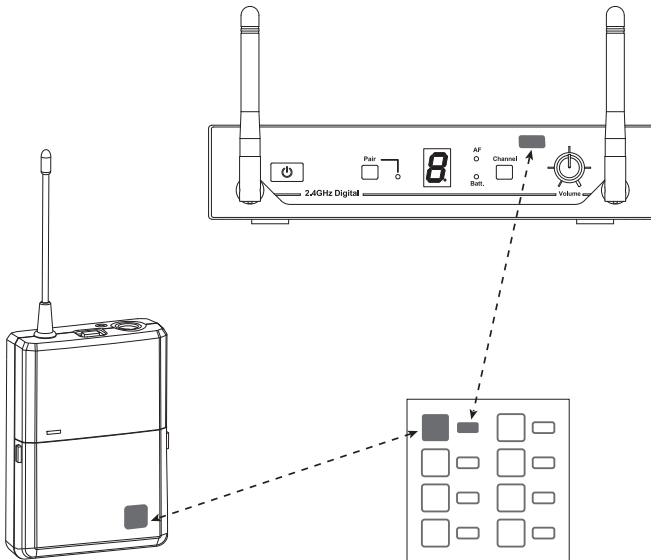

● Trouble Shooting

Problem	Solution
No sound	<ul style="list-style-type: none"> ➤ Check the power supply of the microphone and receiver. ➤ Check that the transmitter and receiver are tuned to the same frequency. ➤ Check whether the hi-fi appliance is switched on and the receiver output is connected to audio mixer or amplifier input. ➤ Check whether receiver is located too near metal object or there are obstructions between transmitter and receiver.
Sound interference	<ul style="list-style-type: none"> ➤ Check the antenna location. ➤ When using 2 or above microphone sets simultaneously, make sure that the chosen frequencies are not interfered. ➤ Check whether the interference comes from other wireless microphones, TV, radio and etc.
Distortion	<ul style="list-style-type: none"> ➤ Check the receiver volume level whether is set too high or too low. ➤ Check whether the interference comes from other wireless microphones, TV, radio and etc.

● Safety

- Do not spill liquid on the appliance and do not drop it on a hard concrete floor.
- Do not place the equipment near heat sources such as radiators, heating ducts, amplifier, etc.
- Do not expose the equipment to direct sunlight, extremely dust, excessive moisture, rain, mechanical vibrations, or shock.
- Take out the battery from transmitter, if the appliance has been not used for a longer period. This will avoid the damage resulting from a defective leaking battery.
- If the equipment is not going to be used for a long time, disconnect the AC adapter from the power outlet. Please note that if you turn the equipment off while leaving the AC adapter plugged in, it is not fully isolated from the power supply.
- **WARNING:** To reduce the risk of fire or electric shock, do not use the products near water and do not expose them to rain or moisture.
- No guarantee claims for the equipment and no liability for any resulting personal damage or material damage will be accepted if the equipment is used for other purpose than originally intended, if the equipment is not correctly connected or operated, or if the equipment is not repaired in an expert way.

● Environment

- Do not throw used batteries into a fire or garbage bin with domestic rubbish. Be sure to dispose of used batteries in accordance with local waste disposal rules.
- When disposing the equipment, remove the batteries, separate the case, circuit boards, and cables, and dispose of all components in accordance with local waste disposal rules.

● System Performance

Receiver

- Frequency Range : ISM 2,400MHz ~ 2,483MHz
- Case : Half 19" EIA Rack Case
- Modulation : FSK digital modulation
- Receiving Mode : True Diversity
- S/N Ratio : >100dB(A)
- Audio Frequency Response : 20Hz to 20kHz
- Audio Sampling : 24bit / 48kHz
- T.H.D. : < 0.1%(at 1kHz)
- Dynamic Range : >100dB
- Latency : < 5.5ms
- Audio Output : Balanced XLR & Unbalanced 1/4" (6.3mm) output
- Power Supply : DC 12V
- Power Consumption : 165mA±10mA
- Dimension(mm) WxHxD : 200 x 42 x 128
- Weight : Approx. 600g

Handheld/Bodypack Transmitter

- Frequency Range : ISM 2,400MHz ~ 2,483MHz
- Channel Select : 2.4G SYNC
- RF Output Power : 10mW
- Transmitting Mode : Frequency hopping
- Max. Audio Input : -10dB = microphone capsule sensitivity
- Battery : 1.5V x2 AA size batteries
- Current Consumption : 195mA±10mA
- Dimension(mm) Ø x L : **Handheld** : Ø 52 x 264
Bodypack : 65 x 97 x 25
- Net Weight : **Handheld** : 240g
Bodypack : 84g

*The specifications are subject to change without notice.