



MEASUREMENT REPORT

FCC PART15.245 / RSS-210 Issue 9

FCC ID: JE4RK825DTGL
IC: 6564A-RK825DTGL
APPLICANT: RISCO LTD.

Application Type: Certification
Product: IWISE DT 25M ACT&GL, US
Model No.: RK825DTGL
FCC Classification: Part 15 Field Disturbance Sensor (FDS)
FCC Rule Part(s): FCC PART15 Subpart C (Section 15.245)
IC Rule(s): RSS-210 Issue 9, RSS-Gen Issue 5
Test Procedure(s): ANSI C63.10-2013
Test Date: August 11 ~ 19, 2018

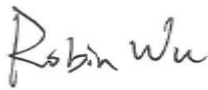
Reviewed By : 
(Sunny Sun)
Approved By : 
(Robin Wu)



The test results relate only to the samples tested.

This equipment has been shown to be capable of compliance with the applicable technical standards as indicated in the measurement report and was tested in accordance with the measurement procedures specified in ANSI C63.10-2013. Test results reported herein relate only to the item(s) tested.

The test report shall not be reproduced except in full without the written approval of MRT Technology (Suzhou) Co., Ltd.

Revision History

Report No.	Version	Description	Issue Date	Note
1808RSU015-U1	Rev. 01	Initial report	08-23-2018	Valid

CONTENTS

Description	Page
1. INTRODUCTION	6
1.1. Scope	6
1.2. MRT Test Location	6
2. PRODUCT INFORMATION	7
2.1. Equipment Description.....	7
2.2. Test Mode	7
2.3. Description of Test Software.....	7
2.4. Duty Cycle	7
2.5. Test Configuration	8
2.6. EMI Suppression Device(s)/Modifications	8
2.7. Labeling Requirements.....	8
3. DESCRIPTION of TEST.....	9
3.1. Evaluation Procedure	9
3.2. AC Line Conducted Emissions	9
3.3. Radiated Emissions	10
4. ANTENNA REQUIREMENTS.....	11
5. TEST EQUIPMENT CALIBRATION DATA	12
6. MEASUREMENT UNCERTAINTY.....	13
7. TEST RESULT	14
7.1. Summary	14
7.2. 99% Bandwidth Measurement	15
7.2.1. Test Limit	15
7.2.2. Test Procedure used.....	15
7.2.3. Test Setting.....	15
7.2.4. Test Setup.....	15
7.2.5. Test Result.....	16
7.3. Radiated Emission.....	17
7.3.1. Test Limit	17
7.3.2. Test Procedure used.....	18
7.3.3. Test Procedure.....	18
7.3.4. Test Setup.....	19
7.3.5. Test Results	21

7.4.	Radiated Restricted Band Edge Measurement	25
7.4.1.	Test Limit	25
7.4.2.	Test Procedure used	27
7.4.3.	Test Procedure.....	27
7.4.4.	Test Setup.....	28
7.4.5.	Test Result.....	29
7.5.	AC Conducted Emissions Measurement.....	33
7.5.1.	Test Limit	33
7.5.2.	Test Setup.....	33
7.5.3.	Test Result.....	33
8.	CONCLUSION.....	34
	Appendix A – Test Setup Photograph.....	35
	Appendix B – EUT Photograph	36

§2.1033 General Information

Applicant:	RISCO LTD.		
Applicant Address:	14 Hachoma Street, Rishon Lezion, 75655, Israel		
Manufacturer:	RISCO LTD.		
Manufacturer Address:	Sderot Yahalom 6 Kiryat Gat, Israel		
Test Site:	MRT Technology (Suzhou) Co., Ltd		
Test Site Address:	D8 Building, No.2 Tian'edang Rd., Wuzhong Economic Development Zone, Suzhou, China		
FCC Registration No.:	893164		
IC Registration No.:	11384A		
Test Device Serial No.:	N/A	<input type="checkbox"/> Production	<input checked="" type="checkbox"/> Pre-Production <input type="checkbox"/> Engineering

Test Facility / Accreditations

Measurements were performed at MRT Laboratory located in Tian'edang Rd., Suzhou, China.

- MRT facility is a FCC registered (MRT Reg. No. 893164) test facility with the site description report on file and has met all the requirements specified in ANSI C63.4-2014.
- MRT facility is an IC registered (MRT Reg. No. 11384A-1) test laboratory with the site description on file at Industry Canada.
- MRT facility is a VCCI registered (R-20025, G-20034, C-20020, T-20020) test laboratory with the site description on file at VCCI Council.
- MRT Lab is accredited to ISO 17025 by the American Association for Laboratory Accreditation (A2LA) under the American Association for Laboratory Accreditation Program (A2LA Cert. No. 3628.01) in EMC, Telecommunications, Radio and SAR testing.



1. INTRODUCTION

1.1. Scope

Measurement and determination of electromagnetic emissions (EMC) of radio frequency devices including intentional and/or unintentional radiators for compliance with the technical rules and regulations of the Federal Communications Commission and the Industry Canada Certification and Engineering Bureau.

1.2. MRT Test Location

The map below shows the location of the MRT LABORATORY, its proximity to the Taihu Lake. These measurement tests were conducted at the MRT Technology (Suzhou) Co., Ltd. Facility located at D8 Building, No.2 Tian'edang Rd., Wuzhong Economic Development Zone, Suzhou, China. The measurement facility compliant with the test site requirements specified in ANSI C63.4-2014.



2. PRODUCT INFORMATION

2.1. Equipment Description

Product Name	IWISE DT 25M ACT&GL, US
Model No.	RK825DTGL
Transmitting Frequency	10.525GHz
Modulation	CW
Operation Voltage	DC 12V
PCB P/N	1PC815DTG300R
HW Version	A
SW Version	V02
MW Module	NJR4178
Antenna Type	Printed Antenna
Antenna Gain	0dBi

2.2. Test Mode

Test Mode	Mode 1: Transmit by 10.525GHz
-----------	-------------------------------

2.3. Description of Test Software

The test utility software used during testing was engineering directive ordered by applicant.

2.4. Duty Cycle

Test Mode	Duty Cycle
10.525GHz	8.95%

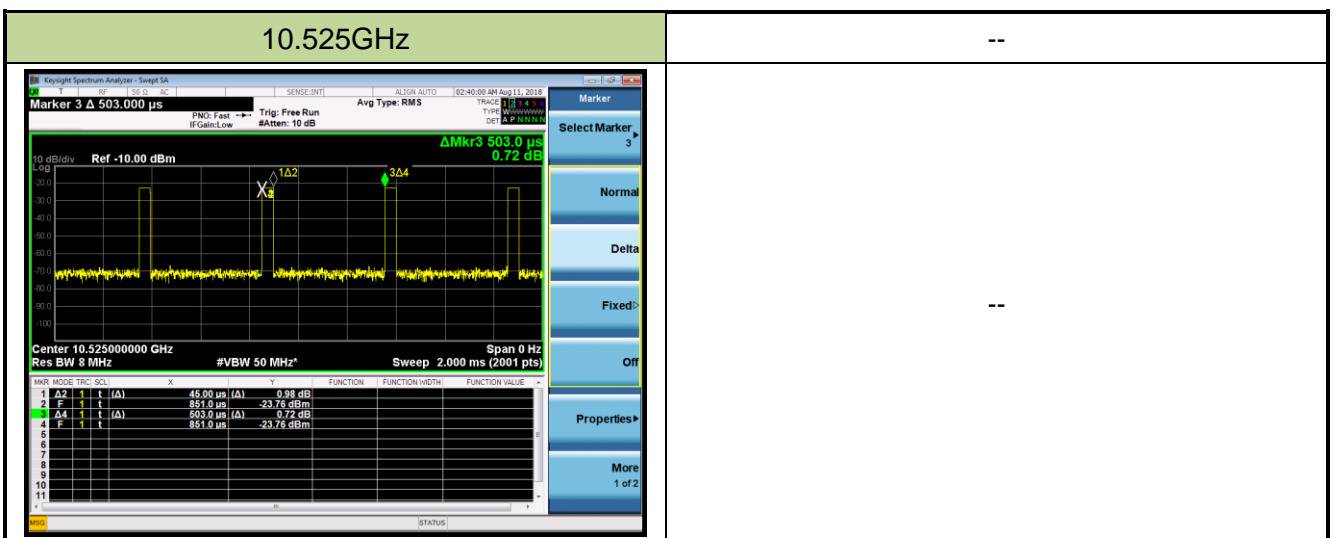

2.5. Test Configuration

The device was tested per the guidance of FCC Part 15.245 and ANSI 63.10-2013 was used to reference the appropriate EUT setup for radiated spurious emissions testing and AC line conducted testing.

2.6. EMI Suppression Device(s)/Modifications

No EMI suppression device(s) were added and/or no modifications were made during testing.

2.7. Labeling Requirements

Per 2.1074 & 15.19; Docket 95-19

The label shall be permanently affixed at a conspicuous location on the device; instruction manual or pamphlet supplied to the user and be readily visible to the purchaser at the time of purchase. However, when the device is so small wherein placement of the label with specified statement is not practical, only the FCC ID must be displayed on the device per Section 15.19(a)(5). Please see attachment for FCC ID label and label location.

RSP-100 Issue 11 Section 3

The manufacturer, importer or distributor shall meet the labelling requirements set out in this section for every unit:

- (i) prior to marketing in Canada, for products manufactured in Canada
- (ii) prior to importation into Canada, for imported products

For information regarding the e-labelling option, see Notice 2014–DRS1003. The label for the certified product represents the manufacturer's or importer's compliance with Innovation, Science and Economic Development Canada's (ISED) regulatory requirements.

Please see attachment for IC label and label location.

3. DESCRIPTION of TEST

3.1. Evaluation Procedure

The measurement procedures described in the American National Standard for Testing Unlicensed Wireless Devices (ANSI C63.10-2013), and the requirement provided in FCC Part 15.245 were used in the measurement of the EUT.

Deviation from measurement procedure.....None

3.2. AC Line Conducted Emissions

The line-conducted facility is located inside an 8'x4'x4' shielded enclosure. A 1m x 2m wooden table 80cm high is placed 40cm away from the vertical wall and 80cm away from the sidewall of the shielded room. Two 10kHz-30MHz, 50Ω/50uH Line-Impedance Stabilization Networks (LISNs) are bonded to the shielded room floor. Power to the LISNs is filtered by external high-current high-insertion loss power line filters. These filters attenuate ambient signal noise from entering the measurement lines. These filters are also bonded to the shielded enclosure.

The EUT is powered from one LISN and the support equipment is powered from the second LISN. All interconnecting cables more than 1 meter were shortened to a 1 meter length by non-inductive bundling (serpentine fashion) and draped over the back edge of the test table. All cables were at least 40cm above the horizontal reference ground-plane. Power cables for support equipment were routed down to the second LISN while ensuring that that cables were not draped over the second LISN.

Sufficient time for the EUT, support equipment, and test equipment was allowed in order for them to warm up to their normal operating condition. The RF output of the LISN was connected to the receiver and exploratory measurements were made to determine the frequencies producing the maximum emission from the EUT. The receiver was scanned from 150kHz to 30MHz. The detector function was set to peak mode for exploratory measurements while the bandwidth of the analyzer was set to 9kHz. The EUT, support equipment, and interconnecting cables were arranged and manipulated to maximize each emission. Each emission was also maximized by varying: power lines, the mode of operation or data exchange speed, or support equipment whichever determined the worst-case emission. Once the worst case emissions have been identified, the one EUT cable configuration/arrangement and mode of operation that produced these emissions are used for final measurements on the same test site. The analyzer is set to CISPR quasi-peak and average detectors with a 9kHz resolution bandwidth for final measurements.

An extension cord was used to connect to a single LISN which powered by EUT. The extension cord was calibrated with LISN, the impedance and insertion loss are compliance with the requirements as stated in ANSI C63.10-2013.

3.3. Radiated Emissions

The radiated test facilities consisted of an indoor 3 meter semi-anechoic chamber used for final measurements and exploratory measurements, when necessary. The measurement area is contained within the semi-anechoic chamber which is shielded from any ambient interference. For measurements above 1GHz absorbers are arranged on the floor between the turn table and the antenna mast in such a way so as to maximize the reduction of reflections. For measurements below 1GHz, the absorbers are removed. A MF Model 210SS turntable is used for radiated measurement. It is a continuously rotatable, remote controlled, metallic turntable and 2 meters (6.56 ft.) in diameter. The turn table is flush with the raised floor of the chamber in order to maintain its function as a ground plane. An 80cm high PVC support structure is placed on top of the turntable.

For all measurements, the spectrum was scanned through all EUT azimuths and from 1 to 4 meter receive antenna height using a broadband antenna from 30MHz up to the upper frequency shown in 15.33(b)(1) depending on the highest frequency generated or used in the device or on which the device operates or tunes. For frequencies above 1GHz, linearly polarized double ridge horn antennas were used. For frequencies below 30MHz, a calibrated loop antenna was used. When exploratory measurements were necessary, they were performed at 1 meter test distance inside the semi-anechoic chamber using broadband antennas, broadband amplifiers, and spectrum analyzers to determine the frequencies and modes producing the maximum emissions. Sufficient time for the EUT, support equipment, and test equipment was allowed in order for them to warm up to their normal operating condition. The test set-up for frequencies below 1GHz was placed on top of the 0.8 meter high, 1 x 1.5 meter table; and test set-up for frequencies 1-40GHz was placed on top of the 1.5 meter high, 1 x 1.5 meter table. The EUT, support equipment, and interconnecting cables were arranged and manipulated to maximize each emission. Appropriate precaution was taken to ensure that all emissions from the EUT were maximized and investigated. The system configuration, clock speed, mode of operation or video resolution, if applicable, turntable azimuth, and receive antenna height was noted for each frequency found.

Final measurements were made in the semi-anechoic chamber using calibrated, linearly polarized broadband and horn antennas. The test setup was configured to the setup that produced the worst case emissions. The spectrum analyzer was set to investigate all frequencies required for testing to compare the highest radiated disturbances with respect to the specified limits. The turntable containing the EUT was rotated through 360 degrees and the height of the receive antenna was varied 1 to 4 meters and stopped at the azimuth and height producing the maximum emission. Each emission was maximized by changing the orientation of the EUT through three orthogonal planes and changing the polarity of the receive antenna, whichever produced the worst-case emissions. According to 3dB Beam-Width of horn antenna, the horn antenna should be always directed to the EUT when rising height.

4. ANTENNA REQUIREMENTS

Excerpt from §15.203 of the FCC Rules/Regulations:

“An intentional radiator antenna shall be designed to ensure that no antenna other than that furnished by the responsible party can be used with the device. The use of a permanently attached antenna or of an antenna that uses a unique coupling to the intentional radiator shall be considered sufficient to comply with the provisions of this section.”

- The antenna of the **IWISE DT 25M ACT&GL, US** is **permanently attached**.
- There are no provisions for connection to an external antenna.

Conclusion:

The unit complies with the requirement of §15.203.

5. TEST EQUIPMENT CALIBRATION DATA

Radiated Emission - AC1

Instrument	Manufacturer	Type No.	Asset No.	Cali. Interval	Cali. Due Date
PXA Signal Analyzer	Keysight	9030B	MRTSUE06395	1 year	2018/09/13
EMI Test Receiver	R&S	ESR7	MRTSUE06001	1 year	2018/08/14
					2019/08/14
Loop Antenna	Schwarzbeck	FMZB 1519	MRTSUE06025	1 year	2018/11/20
EXA Signal Analyzer	Agilent	N9020A	MRTSUE06106	1 year	2019/04/20
Microwave System Amplifier	Agilent	83017A	MRTSUE06076	1 year	2018/11/17
Bilog Period Antenna	Schwarzbeck	VULB 9168	MRTSUE06172	1 year	2018/11/18
Broad Band Horn Antenna	Schwarzbeck	BBHA9120D	MRTSUE06023	1 year	2018/10/21
Broad Band Horn Antenna	Schwarzbeck	BBHA 9170	MRTSUE06024	1 year	2018/12/14
Micro-Wave Antenna	MI-WWAVE	261U-25	MRTSUE06273	1 year	2018/12/26
Waveguide Harmonic Mixer	Keysight	M1970V	MRTSUE06271	1 year	2018/12/26
Amplifier	Schwarzbeck	BBV 9721	MRTSUE06121	1 year	2019/06/13
DC Power Supply	GWINSTEK	DPS-99306D	MRTSUE06063	1 year	N/A
Hygrothermograph	Testo	608-H1	MRTSUE06403	1 year	2018/08/14
					2019/08/14
Anechoic Chamber	TDK	Chamber-AC1	MRTSUE06212	1 year	2019/05/02

6. MEASUREMENT UNCERTAINTY

Where relevant, the following test uncertainty levels have been estimated for tests performed on the EUT as specified in CISPR 16-4-2. This uncertainty represents an expanded uncertainty expressed at approximately the 95% confidence level using a coverage factor of $k = 2$.

Radiated Emission Measurement - AC1

Measuring Uncertainty for a Level of Confidence of 95% ($U=2Uc(y)$):

9kHz ~ 1GHz: 4.18dB

1GHz ~ 18GHz: 4.76dB

7. TEST RESULT

7.1. Summary

Company Name: RISCO LTD.
FCC ID: JE4RK825DTGL
IC: 6564A-RK825DTGL

FCC Part Section(s)	Test Description	Test Limit	Test Condition	Test Result	Reference
15.215(c)	Occupied Bandwidth	N/A	Radiated	Pass	Section 7.2
15.209 15.245	General Field Strength Limits (Restricted Bands and Radiated Emission Limits)	Emissions in restricted bands must meet the radiated limits detailed in 15.209		Pass	Section 7.3 & 7.4
15.207	AC Conducted Emissions 150kHz - 30MHz	< FCC 15.207 limits	Line Conducted	N/A	Section 7.5

RSS Section(s)	Test Description	Test Limit	Test Condition	Test Result	Reference
RSS-Gen Clause 6.7	Occupied Bandwidth	N/A	Radiated	Pass	Section 7.2
RSS-Gen Clause 8.9, RSS-210 Annex F.1	General Field Strength Limits (Restricted Bands and Radiated Emission Limits)	Emissions in restricted bands must meet the radiated limits detailed in clause 8.10		Pass	Section 7.3 & 7.4
RSS-Gen Clause 8.8	AC Conducted Emissions 150kHz - 30MHz	< RSS-Gen Clause 8.8 limits	Line Conducted	N/A	Section 7.5

Notes:

- 1) The analyzer plots shown in this section were all taken with a correction table loaded into the analyzer. The correction table was used to account for the losses of the cables and attenuators used as part of the system to connect the EUT to the analyzer at all frequencies of interest.
- 2) The radiation measurements are performed in X, Y, Z axis positioning. Only the worst case is shown in the report.

7.2. 99% Bandwidth Measurement

7.2.1. Test Limit

N/A

7.2.2. Test Procedure used

ANSI C63.10 Section 6.9

7.2.3. Test Setting

1. The analyzers' automatic bandwidth measurement capability was used to perform the 99% bandwidth measurement. The bandwidth measurement was not influenced by any intermediated power nulls in the fundamental emission.
2. RBW = approximately 1% to 5% of the OBW.
3. VBW $\geq 3 \times$ RBW.
4. Detector = Peak.
5. Trace mode = max hold.

7.2.4. Test Setup

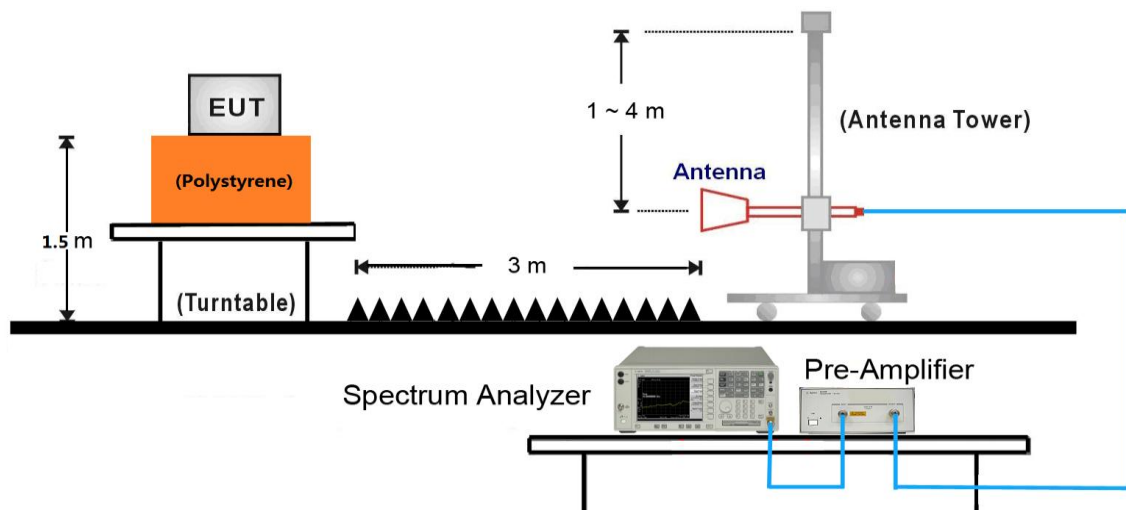

7.2.5. Test Result

Product	IWISE DT 25M ACT&GL, US	Temperature	24°C
Test Engineer	Flag Yang	Relative Humidity	54%
Test Site	AC1	Test Date	2018/08/11

Frequency (GHz)	99% Bandwidth (KHz)
10.525	362.49

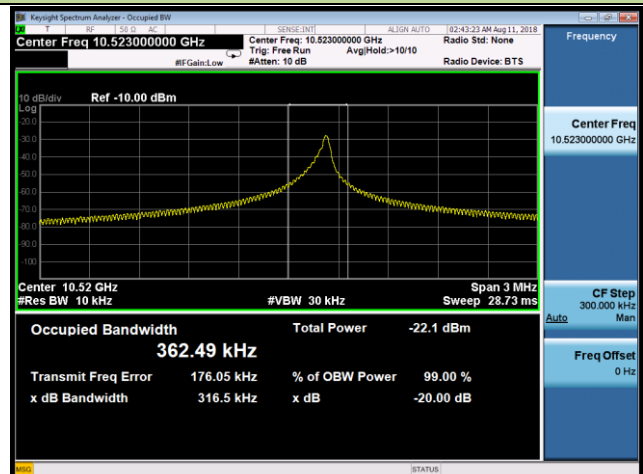
99% Occupied Bandwidth	
10.525GHz	--
 <p>Keysight Spectrum Analyzer - Occupied BW</p> <p>Center Freq: 10.523000000 GHz</p> <p>Occupied Bandwidth: 362.49 kHz</p> <p>Total Power: -22.1 dBm</p> <p>Transmit Freq Error: 176.05 kHz</p> <p>% of OBW Power: 99.00 %</p>	--

7.3. Radiated Emission

7.3.1. Test Limit

FCC Part 15 Subpart C Paragraph 15.245 & RSS 210		
Fundamental frequency (MHz)	Field strength of fundamental (millivolts/meter)	Field strength of harmonics (millivolts/meter)
902 – 928	500	1.6
2435 – 2465	500	1.6
5785 – 5815	500	1.6
10500 – 10550	2500	25.0
24075 – 24175	2500	25.0

Note 1: Regardless of the limits shown in the above table, harmonic emissions in the restricted bands below 17.7 GHz, as specified in §15.205, shall not exceed the field strength limits shown in § 15.209. Harmonic emissions in the restricted bands at and above 17.7GHz shall not exceed the following field strength limits:

- (i) For the second and third harmonics of field disturbance sensors operating in the 24075-24175 MHz band and for other field disturbance sensors designed for use only within a building or to open building doors, 25.0 mV/m.
- (ii) For all other field disturbance sensors, 7.5 mV/m.
- (iii) Field disturbance sensors designed to be used in motor vehicles or aircraft must include features to prevent continuous operation unless their emissions in the restricted bands, other than the second and third harmonics from devices operating in the 24075-24175 MHz band, fully comply with the limits given in § 15.209. Continuous operation of field disturbance sensors designed to be used in farm equipment, vehicles such as fork lifts that are intended primarily for use indoors or for very specialized operations, or railroad locomotives, railroad cars and other equipment which travels on fixed tracks is permitted. A field disturbance sensor will be considered not to be operating in a continuous mode if its operation is limited to specific activities of limited duration (e.g., putting a vehicle into reverse gear, activating a turn signal, etc.).

Note 2: Emissions radiated outside of the specified frequency bands, except for harmonics, shall be attenuated by at least 50 dB below the level of the fundamental or to the general radiated emission limits in §15.209, whichever is the lesser attenuation.

Note 3: Field strength limits are specified at a distance of 3 meters.

Note 4: The emission limits shown above are based on measurement instrumentation employing an average detector. The provisions in §15.35 for limiting peak emissions apply.

FCC Part 15 Subpart C Paragraph 15.209 & RSS-Gen		
Frequency (MHz)	Field Strength (uV/m)	Measurement Distance (m)
0.009 ~ 0.490	2400/F(kHz)	300
0.490 ~ 1.705	24000/F(kHz)	30
1.705 ~ 30.0	30	30
30 ~ 80	100**	3
80 ~ 216	150**	3
216 ~ 960	200**	3
Above 960	500	3

Note 1: The lower limit shall apply at the transition frequency.
 Note 2: Distance refers to the distance in meters between the measuring instrument antenna and the closed point of any part of the device or system.
 Note 3: E field strength (dBuV/m) = 20 log E field strength (uV/m).

7.3.2. Test Procedure used

ANSI C63.10 Section 6.6

7.3.3. Test Procedure

Peak Field Strength Measurements

1. Analyzer center frequency was set to the frequency of the radiated spurious emission of interest
2. RBW = as specified in Table 1
3. VBW = 3MHz
4. Detector = peak
5. Sweep time = auto couple
6. Trace mode = max hold
7. Trace was allowed to stabilize

Table 1 - RBW as a function of frequency

Frequency	RBW
9 ~ 150 kHz	200 ~ 300 Hz
0.15 ~ 30 MHz	9 ~ 10 kHz
30 ~ 1000 MHz	100 ~ 120 kHz
> 1000 MHz	1 MHz

Average Field Strength Measurements

1. Analyzer center frequency was set to the frequency of the radiated spurious emission of interest
2. RBW = 1MHz
3. VBW $\geq 1/T$
4. De As an alternative, the instrument may be set to linear detector mode. Ensure that video filtering is applied in linear voltage domain (rather than in a log or dB domain). Some instruments require linear display mode in order to accomplish this. Others have a setting for Average-VBW Type, which can be set to "Voltage" regardless of the display mode
5. Detector = Peak
6. Sweep time = auto
7. Trace mode = max hold
8. Allow max hold to run for at least 50 times (1/duty cycle) traces

7.3.4. Test Setup

9kHz ~ 30MHz Test Setup:

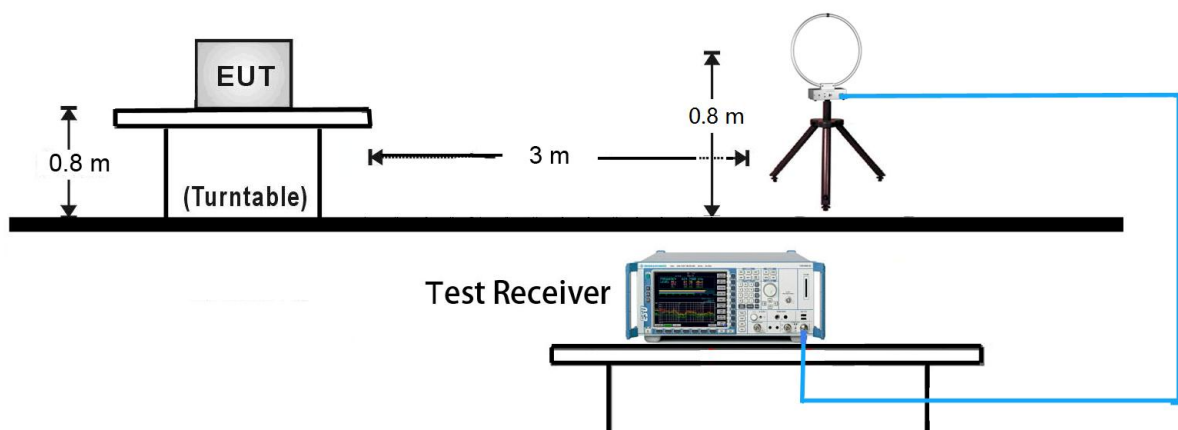

30MHz ~ 1GHz Test Setup:

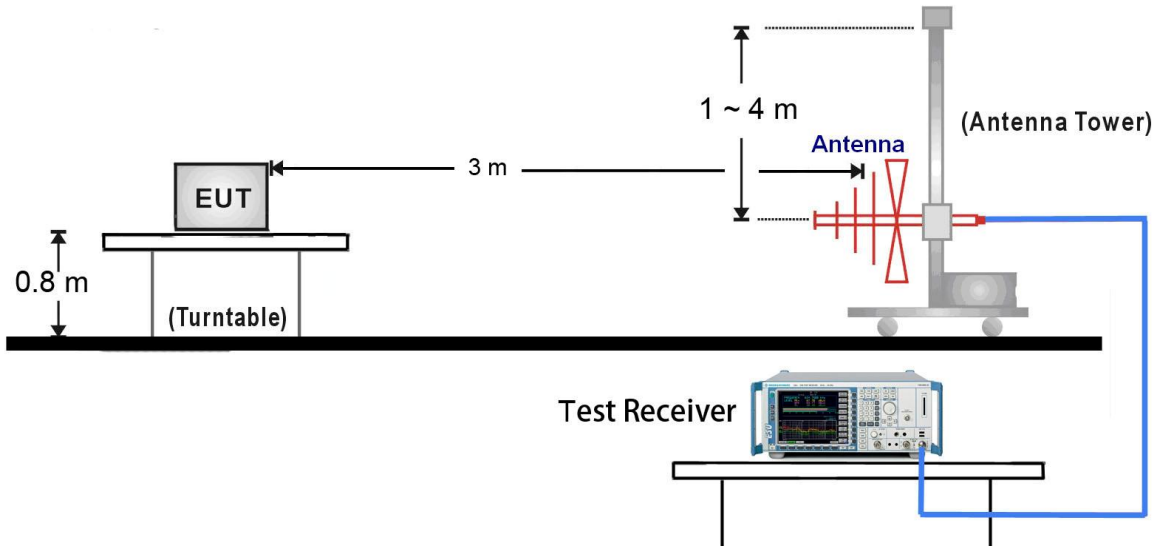

1GHz ~ 40GHz Test Setup:

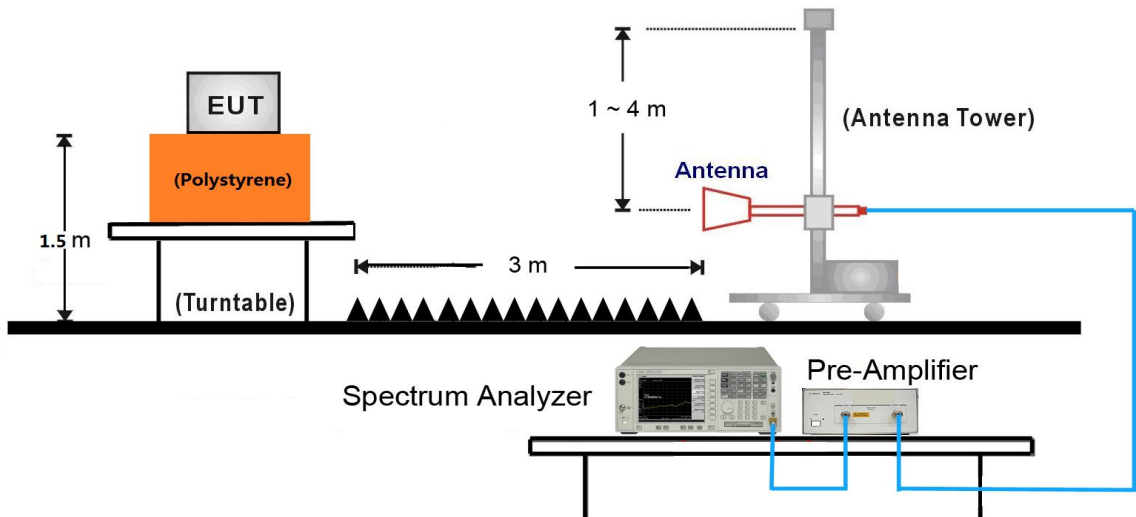

40GHz ~ 60GHz Test Setup:

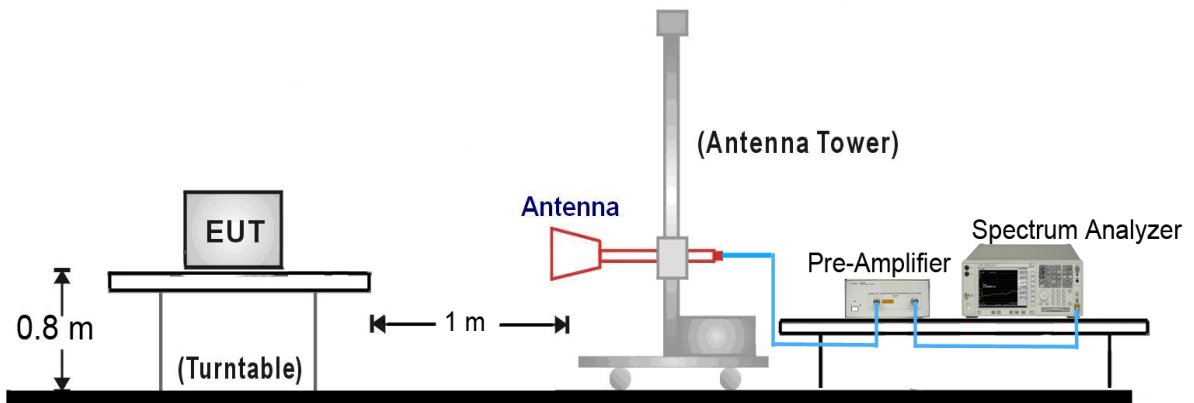

7.3.5. Test Results

Product	IWISE DT 25M ACT&GL, US	Temperature	23°C
Test Engineer	Flag Yang	Relative Humidity	54%
Test Site	AC1	Test Date	2018/08/19
Remark:	Fundamental Radiated Emission		

Frequency (GHz)	Reading Level (dB μ V)	Factor (dB)	Measure Level (dB μ V/m)	Limit (dB μ V/m)	Margin (dB)	Detector	Polarization
10.525	87.7	17.6	105.3	148.0	-42.7	Peak	Horizontal
	86.8	17.6	104.4	128.0	-23.6	Average	Horizontal
	73.0	17.6	90.6	148.0	-57.4	Peak	Vertical
	72.6	17.6	90.2	128.0	-37.8	Average	Vertical

Note 1: Peak Measure Level (dB μ V/m) = Reading Level (dB μ V) + Factor (dB)

Factor (dB) = Cable Loss (dB) + Antenna Factor (dB/m)

Product	IWISE DT 25M ACT&GL, US	Temperature	23°C
Test Engineer	Flag Yang	Relative Humidity	54%
Test Site	AC1	Test Date	2018/08/17
Remark:	Harmonics Radiated Emission		

Mark	Frequency (MHz)	Reading Level (dBμV)	Factor (dB)	Measure Level (dBμV/m)	Limit (dBμV/m)	Margin (dB)	Detector	Polarization
	1374.0	42.8	-4.0	38.8	74.0	-35.2	Peak	Horizontal
	1374.0	31.1	-4.0	27.1	54.0	-26.9	Average	Horizontal
	2972.0	39.8	0.7	40.5	74.0	-33.5	Peak	Horizontal
	2972.0	28.7	0.7	29.4	54.0	-24.6	Average	Horizontal
	1467.5	42.5	-4.0	38.5	74.0	-35.5	Peak	Vertical
	1467.5	31.3	-4.0	27.3	54.0	-26.7	Average	Vertical
	3235.5	38.4	1.1	39.5	74.0	-34.5	Peak	Vertical
	3235.5	27.2	1.1	28.3	54.0	-25.7	Average	Vertical
*	21047.0	42.0	8.1	50.1	108.0	-57.9	Peak	Horizontal
*	21047.5	41.6	8.1	49.7	88.0	-38.3	Average	Horizontal
*	31574.0	53.4	12.8	66.2	108.0	-41.8	Peak	Horizontal
*	31574.8	53.1	12.8	65.9	88.0	-22.1	Average	Horizontal
*	21047.0	43.4	8.1	51.5	108.0	-56.5	Peak	Vertical
*	21047.6	42.9	8.1	51.0	88.0	-37.0	Average	Vertical
*	31574.0	51.8	12.8	64.6	108.0	-43.4	Peak	Vertical
*	31574.0	51.4	12.8	64.2	88.0	-23.8	Average	Vertical

Note 1: "*" is Harmonic emissions in the restricted bands, its limit is 25 mV/m.

Note 2: AV Limit (dBuV/m at 3m) = $\{20 \cdot \log[(25/1000)] + 120\}$ dBuV/m = 88 dBuV/m

PK Limit (dBuV/m at 3m) = AV Limit (dBuV/m at 3m) + 20dB = 108 dBuV/m

Note 3: Measure Level (dBμV/m) = Reading Level (dBμV) + Factor (dB)

Factor (dB) = Cable Loss (dB) + Antenna Factor (dB/m) - Pre_Amplifier Gain (dB)

Radiated Emission below 1GHz:

Site: AC1	Time: 2018/08/17 - 00:30
Limit: FCC_Part15.209_RE(3m)	Engineer: Flag Yang
Probe: VULB 9168 _20-2000MHz	Polarity: Horizontal
EUT: IWISE DT 25M ACT&GL, US	Power: DC 12V
Test Mode: Transmit at Channel 10.525GHz	

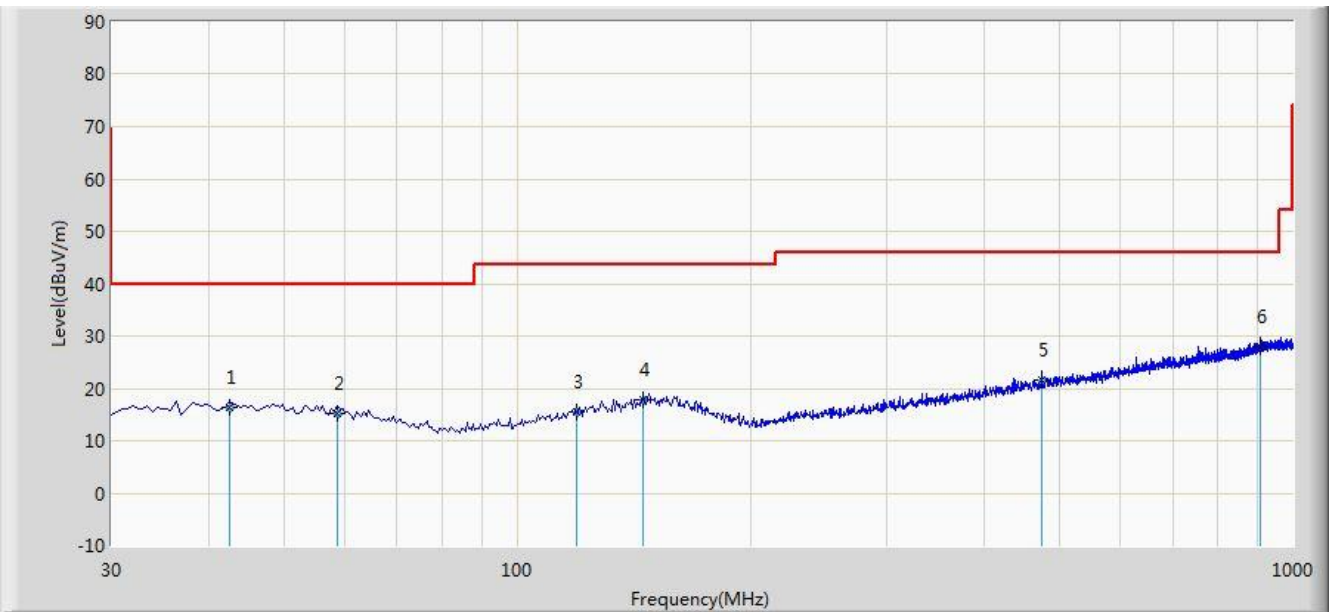

No	Flag	Mark	Frequency (MHz)	Measure Level (dBuV/m)	Reading Level (dBuV)	Over Limit (dB)	Limit (dBuV/m)	Factor (dB)	Type
1			42.610	16.483	2.030	-23.517	40.000	14.452	QP
2			58.615	15.135	1.570	-24.865	40.000	13.565	QP
3			119.240	15.508	2.360	-27.992	43.500	13.148	QP
4			145.430	17.697	2.730	-25.803	43.500	14.967	QP
5			474.745	21.500	3.290	-24.500	46.000	18.210	QP
6		*	907.850	28.096	3.550	-17.904	46.000	24.546	QP

Note 1: Measure Level (dBuV/m) = Reading Level (dBuV) + Factor (dB)

Factor (dB) = Cable Loss (dB) + Antenna Factor (dB/m)

Note 2: The test trace is same as the ambient noise and the amplitude of the emissions are attenuated more than 20dB below the permissible (the test frequency range: 9kHz ~ 30MHz, 40GHz ~ 60GHz), therefore no data appear in the report.

Site: AC1	Time: 2018/08/17 - 00:41
Limit: FCC_Part15.209_RE(3m)	Engineer: Flag Yang
Probe: VULB 9168 _20-2000MHz	Polarity: Vertical
EUT: IWISE DT 25M ACT&GL, US	Power: DC 12V
Test Mode: Transmit at Channel 10.525GHz	

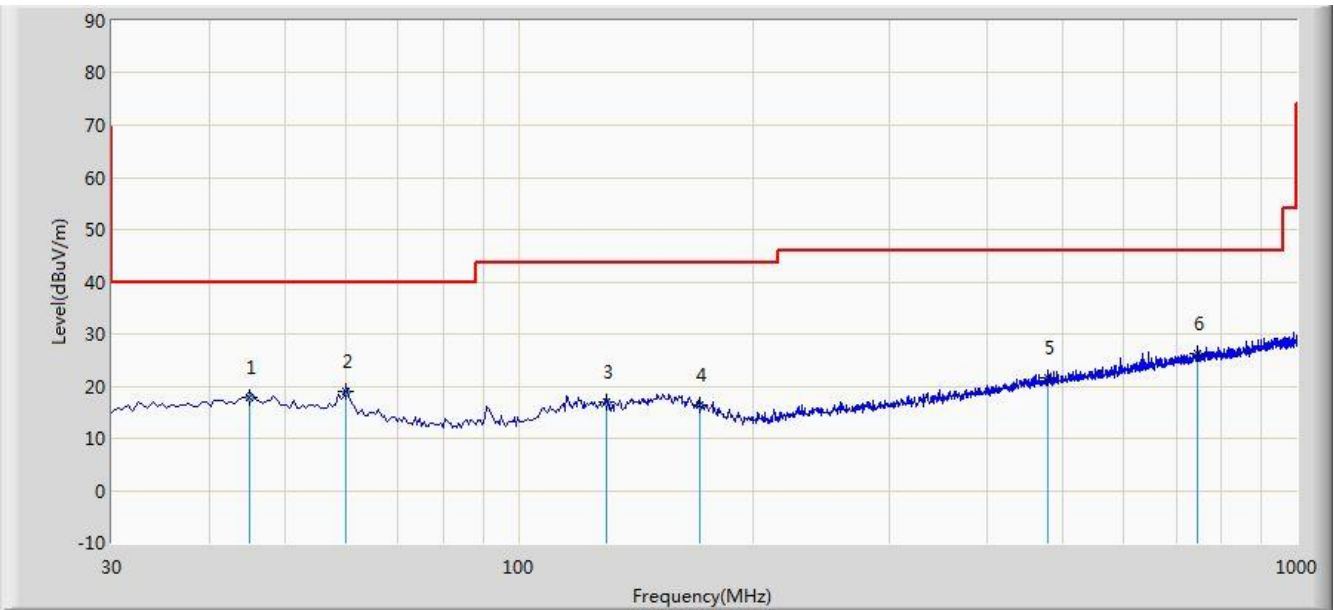

No	Flag	Mark	Frequency (MHz)	Measure Level (dBuV/m)	Reading Level (dBuV)	Over Limit (dB)	Limit (dBuV/m)	Factor (dB)	Type
1			45.035	17.861	3.560	-22.139	40.000	14.302	QP
2			60.070	18.905	5.490	-21.095	40.000	13.415	QP
3			129.426	16.913	3.110	-26.587	43.500	13.803	QP
4			170.650	16.343	2.060	-27.157	43.500	14.283	QP
5			479.595	21.564	3.290	-24.436	46.000	18.274	QP
6		*	744.890	26.289	3.560	-19.711	46.000	22.729	QP

Note 1: Measure Level (dBuV/m) = Reading Level (dBuV) + Factor (dB)

Factor (dB) = Cable Loss (dB) + Antenna Factor (dB/m)

Note 2: The test trace is same as the ambient noise and the amplitude of the emissions are attenuated more than 20dB below the permissible (the test frequency range: 9kHz ~ 30MHz, 40GHz ~ 60GHz), therefore no data appear in the report.

7.4. Radiated Restricted Band Edge Measurement

7.4.1. Test Limit

For 15.205 requirement:

Radiated emissions which fall in the restricted bands, as defined in Section 15.205(a) of FCC part 15, must also comply with the radiated emission limits specified in Section 15.209(a).

Frequency (MHz)	Frequency (MHz)	Frequency (MHz)	Frequency (GHz)
0.090 - 0.110	16.42 - 16.423	399.9 - 410	4.5 - 5.15
¹ 0.495 - 0.505	16.69475 - 16.69525	608 - 614	5.35 - 5.46
2.1735 - 2.1905	16.80425 - 16.80475	960 - 1240	7.25 - 7.75
4.125 - 4.128	25.5 - 25.67	1300 - 1427	8.25 - 8.5
4.17725 - 4.17775	37.5 - 38.25	1435 - 1626.5	9.0 - 9.2
4.20725 - 4.20775	73 - 74.6	1645.5 - 1646.5	9.3 - 9.5
6.215 - 6.218	74.8 - 75.2	1660 - 1710	10.6 - 12.7
6.26775 - 6.26825	108 - 121.94	1718.8 - 1722.2	13.25 - 13.4
6.31175 - 6.31225	123 - 138	2200 - 2300	14.47 - 14.5
8.291 - 8.294	149.9 - 150.05	2310 - 2390	15.35 - 16.2
8.362 - 8.366	156.52475 - 156.525	2483.5 - 2500	17.7 - 21.4
8.37625 - 8.38675	156.7 - 156.9	2690 - 2900	22.01 - 23.12
8.41425 - 8.41475	162.0125 - 167.17	3260 - 3267	23.6 - 24.0
12.29 - 12.293	167.72 - 173.2	3332 - 3339	31.2 - 31.8
12.51975 - 12.52025	240 - 285	3345.8 - 3358	36.43 - 36.5
12.57675 - 12.57725	322 - 335.4	3600 - 4400	(²)
13.36 - 13.41	--	--	--

All out of band emissions appearing in a restricted band as specified in Section 15.205 of the Title 47 CFR must not exceed the limits shown in Table per Section 15.209.

FCC Part 15 Subpart C Paragraph 15.209		
Frequency [MHz]	Field Strength [$\mu\text{V}/\text{m}$]	Measured Distance [Meters]
0.009 ~ 0.490	2400/F (kHz)	300
0.490 ~ 1.705	24000/F (kHz)	30
1.705 ~ 30	30	30
30 ~ 88	100	3
88 ~ 216	150	3
216 ~ 960	200	3
Above 960	500	3

For RSS-Gen Section 8.10 Requirement:

Radiated emissions which fall in the restricted bands, as defined in Section 8.10 of RSS-Gen, must also comply with the radiated emission limits specified in Section 8.9.

Frequency (MHz)	Frequency (MHz)	Frequency (MHz)	Frequency (GHz)
0.090 - 0.110	16.42 - 16.423	1645.5 - 1646.5	9.0 - 9.2
0.495 - 0.505	16.69475 - 16.69525	1660 - 1710	9.3 - 9.5
2.1735 - 2.1905	16.80425 - 16.80475	1718.8-1722.2	10.6 - 12.7
3.020 - 3.026	25.5 - 25.67	2200 - 2300	13.25 - 13.4
4.125 - 4.128	37.5 - 38.25	2310-2390	14.47 - 14.5
4.17725 - 4.17775	73 - 74.6	2483.5 - 2500	15.35 - 16.2
4.20725 - 4.20775	74.8 - 75.2	2655 - 2900	17.7 - 21.4
5.677 - 5.683	108 - 138	3260 - 3267	22.01 - 23.12
6.215 - 6.218	149.9 - 150.05	3332 - 3339	23.6 - 24.0
6.26775 - 6.26825	156.52475 - 156.52525	3345.8 - 3358	31.2 - 31.8
6.31175 - 6.31225	156.7 - 156.9	3500 - 4400	36.43 - 36.5
8.291 - 8.294	162.0125 - 167.17	4500 - 5150	Above 38.6
8.362 - 8.366	167.72 - 173.2	5350 - 5460	--
8.37625 - 8.38675	240 - 285	7250 - 7750	--
8.41425 - 8.41475	322 - 335.4	8025 - 8500	--
12.29 - 12.293	399.9 - 410	--	--
12.51975 - 12.52025	608 - 614	--	--
12.57675 - 12.57725	960 - 1427	--	--
13.36 -13.41	1435 - 1626.5	--	--

7.4.2. Test Procedure used

ANSI C63.10 Section 6.6

7.4.3. Test Procedure

Peak Field Strength Measurements

1. 1Analyzer center frequency was set to the frequency of the radiated spurious emission of interest
2. RBW = 1MHz
3. VBW = 3MHz
4. Detector = peak
5. Sweep time = auto couple

6. Trace mode = max hold
7. Trace was allowed to stabilize

Average Field Strength Measurements

1. Analyzer center frequency was set to the frequency of the radiated spurious emission of interest
2. RBW = 1MHz
3. VBW $\geq 1/T$
4. As an alternative, the instrument may be set to linear detector mode. Ensure that video filtering is applied in linear voltage domain (rather than in a log or dB domain). Some instruments require linear display mode in order to accomplish this. Others have a setting for Average-VBW Type, which can be set to "Voltage" regardless of the display mode
5. Detector = Peak
6. Sweep time = auto
7. Trace mode = max hold
8. Allow max hold to run for at least 50 times (1/duty cycle) traces

7.4.4. Test Setup

1GHz ~ 18GHz Test Setup:

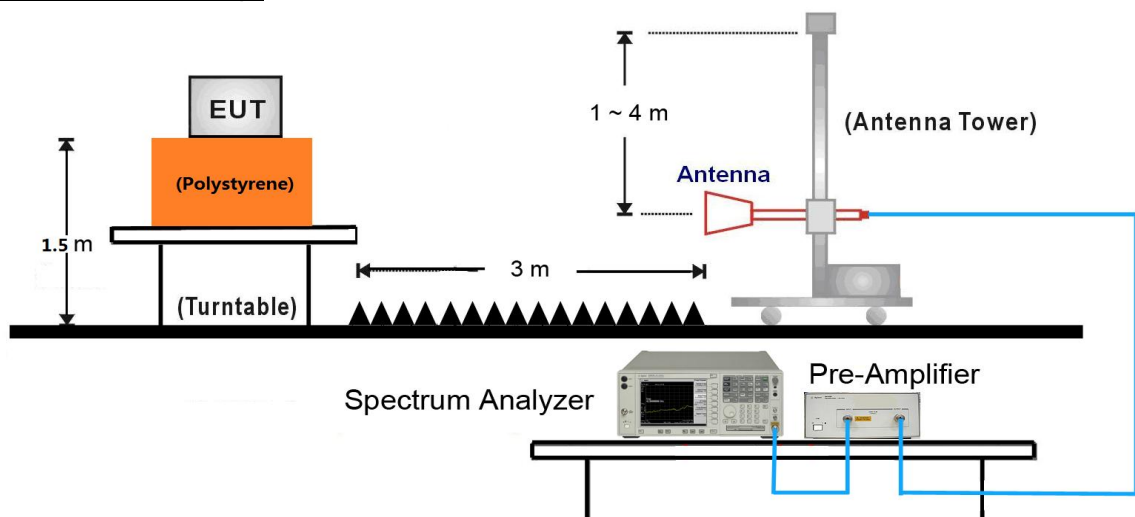

7.4.5. Test Result

Site: AC1	Time: 2018/08/19 - 01:56
Limit: FCC_Part15.209_RE(3m)	Engineer: Flag Yang
Probe: BBHA9120D_1-18GHz	Polarity: Horizontal
EUT: IWISE DT 25M ACT&GL, US	Power: DC 12V
Test Mode: Transmit at channel 10.525GHz	

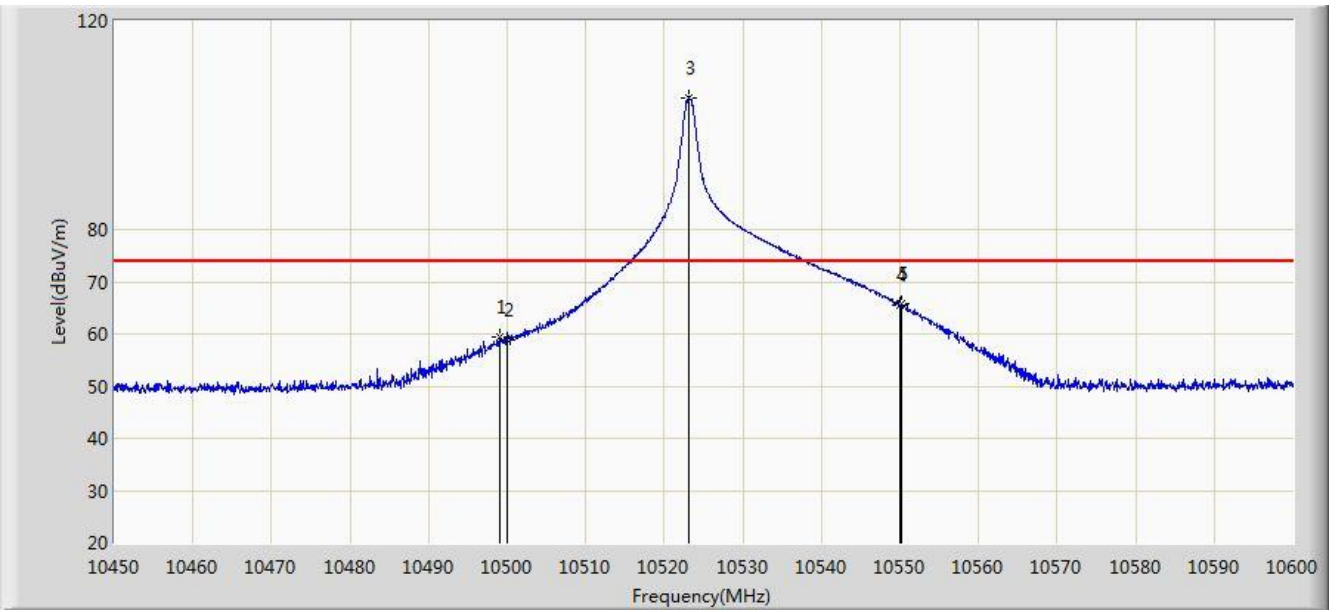

No	Flag	Mark	Frequency (MHz)	Measure Level (dBuV/m)	Reading Level (dBuV)	Over Limit (dB)	Limit (dBuV/m)	Factor (dB)	Type
1			10498.975	59.290	41.702	-14.710	74.000	17.588	PK
2			10500.000	58.898	41.303	-15.102	74.000	17.595	PK
3		*	10523.200	105.335	87.748	N/A	N/A	17.586	PK
4			10550.000	65.471	47.789	-8.529	74.000	17.681	PK
5			10550.275	65.921	48.239	-8.079	74.000	17.683	PK

Note: Peak Measure Level (dBμV/m) = Reading Level (dBμV) + Factor (dB)

Factor (dB) = Cable Loss (dB) + Antenna Factor (dB/m)

Site: AC1	Time: 2018/08/19 - 02:09
Limit: FCC_Part15.209_RE(3m)	Engineer: Flag Yang
Probe: BBHA9120D_1-18GHz	Polarity: Horizontal
EUT: IWISE DT 25M ACT&GL, US	Power: DC 12V
Test Mode: Transmit at channel 10.525GHz	

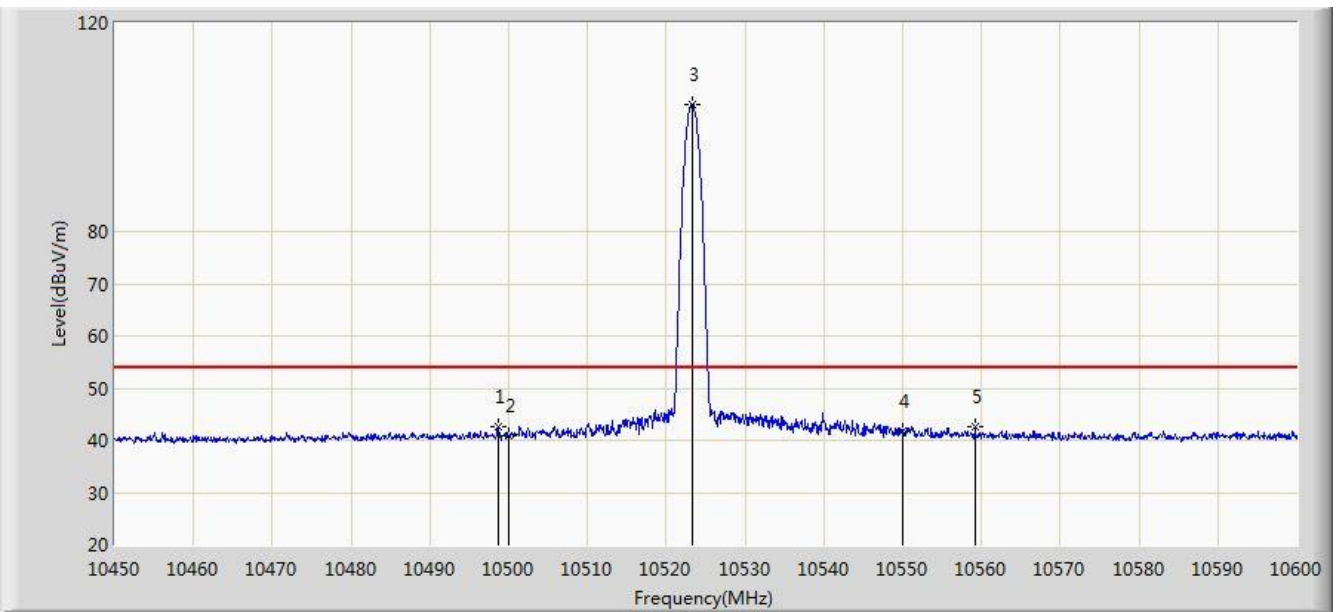

No	Flag	Mark	Frequency (MHz)	Measure Level (dBuV/m)	Reading Level (dBuV)	Over Limit (dB)	Limit (dBuV/m)	Factor (dB)	Type
1			10498.600	42.597	25.013	-11.403	54.000	17.583	AV
2			10500.000	40.957	23.362	-13.043	54.000	17.595	AV
3		*	10523.275	104.406	86.818	N/A	N/A	17.588	AV
4			10550.000	41.623	23.941	-12.377	54.000	17.681	AV
5			10559.200	42.583	24.895	-11.417	54.000	17.687	AV

Note: Peak Measure Level (dB μ V/m) = Reading Level (dB μ V) + Factor (dB)

Factor (dB) = Cable Loss (dB) + Antenna Factor (dB/m)

Site: AC1	Time: 2018/08/19 - 02:20
Limit: FCC_Part15.209_RE(3m)	Engineer: Flag Yang
Probe: BBHA9120D_1-18GHz	Polarity: Vertical
EUT: IWISE DT 25M ACT&GL, US	Power: DC 12V
Test Mode: Transmit at channel 10.525GHz	

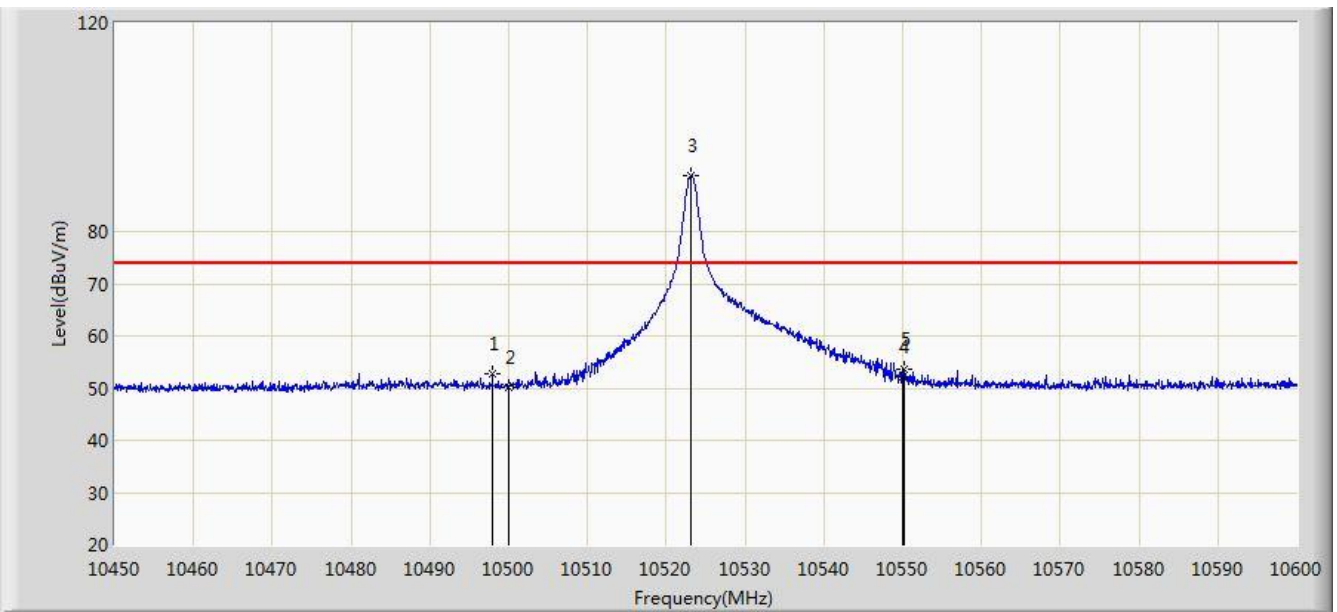

No	Flag	Mark	Frequency (MHz)	Measure Level (dBuV/m)	Reading Level (dBuV)	Over Limit (dB)	Limit (dBuV/m)	Factor (dB)	Type
1			10497.925	52.822	35.245	-21.178	74.000	17.577	PK
2			10500.000	50.129	32.534	-23.871	74.000	17.595	PK
3		*	10523.125	90.620	73.033	N/A	N/A	17.586	PK
4			10550.000	52.283	34.601	-21.717	74.000	17.681	PK
5			10550.125	53.744	36.062	-20.256	74.000	17.683	PK

Note: Peak Measure Level (dB μ V/m) = Reading Level (dB μ V) + Factor (dB)

Factor (dB) = Cable Loss (dB) + Antenna Factor (dB/m)

Site: AC1	Time: 2018/08/19 - 02:23
Limit: FCC_Part15.209_RE(3m)	Engineer: Flag Yang
Probe: BBHA9120D_1-18GHz	Polarity: Vertical
EUT: IWISE DT 25M ACT&GL, US	Power: DC 12V
Test Mode: Transmit at channel 10.525GHz	

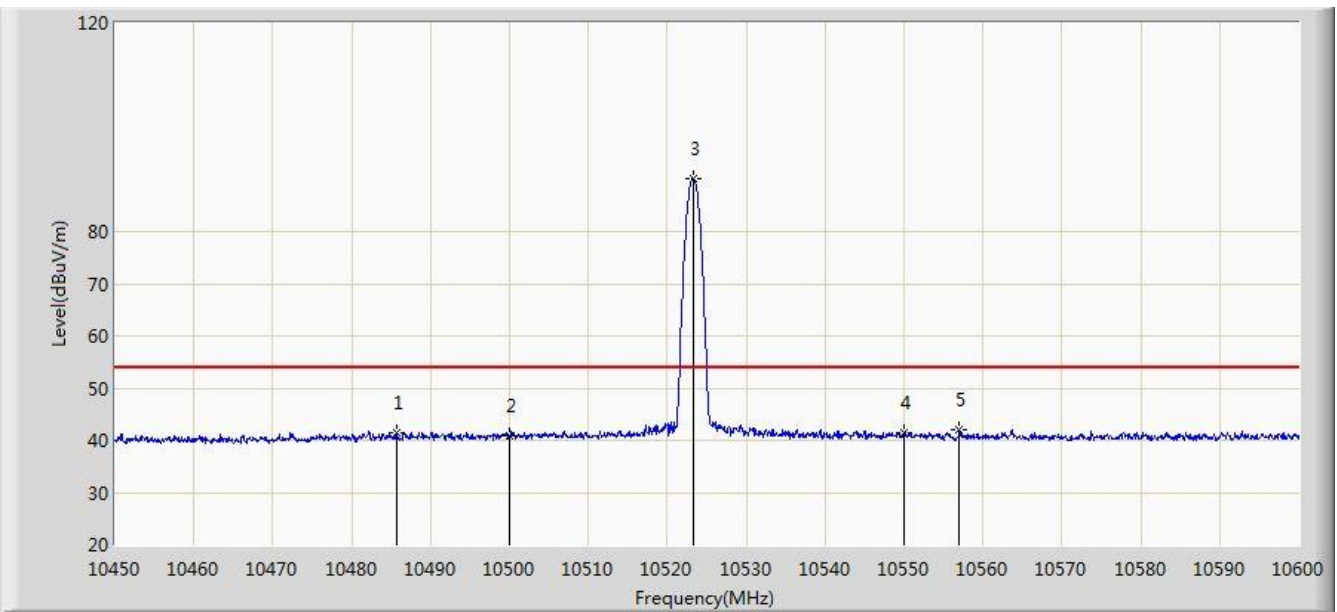

No	Flag	Mark	Frequency (MHz)	Measure Level (dBuV/m)	Reading Level (dBuV)	Over Limit (dB)	Limit (dBuV/m)	Factor (dB)	Type
1			10485.700	41.589	24.138	-12.411	54.000	17.450	AV
2			10500.000	40.751	23.156	-13.249	54.000	17.595	AV
3		*	10523.275	90.213	72.625	N/A	N/A	17.588	AV
4			10550.000	41.374	23.692	-12.626	54.000	17.681	AV
5			10557.025	41.943	24.255	-12.057	54.000	17.688	AV

Note: Peak Measure Level (dBμV/m) = Reading Level (dBμV) + Factor (dB)

Factor (dB) = Cable Loss (dB) + Antenna Factor (dB/m)

7.5. AC Conducted Emissions Measurement

7.5.1. Test Limit

FCC 15.207 & RSS-Gen Limits		
Frequency (MHz)	QP (dBuV)	AV (dBuV)
0.15 ~ 0.50	66 ~ 56	56 ~ 46
0.50 ~ 5.0	56	46
5.0 ~ 30	60	50

Note 1: The lower limit shall apply at the transition frequencies.

Note 2: The limit decreases linearly with the logarithm of the frequency in the range 0.15MHz to 0.5MHz.

7.5.2. Test Setup

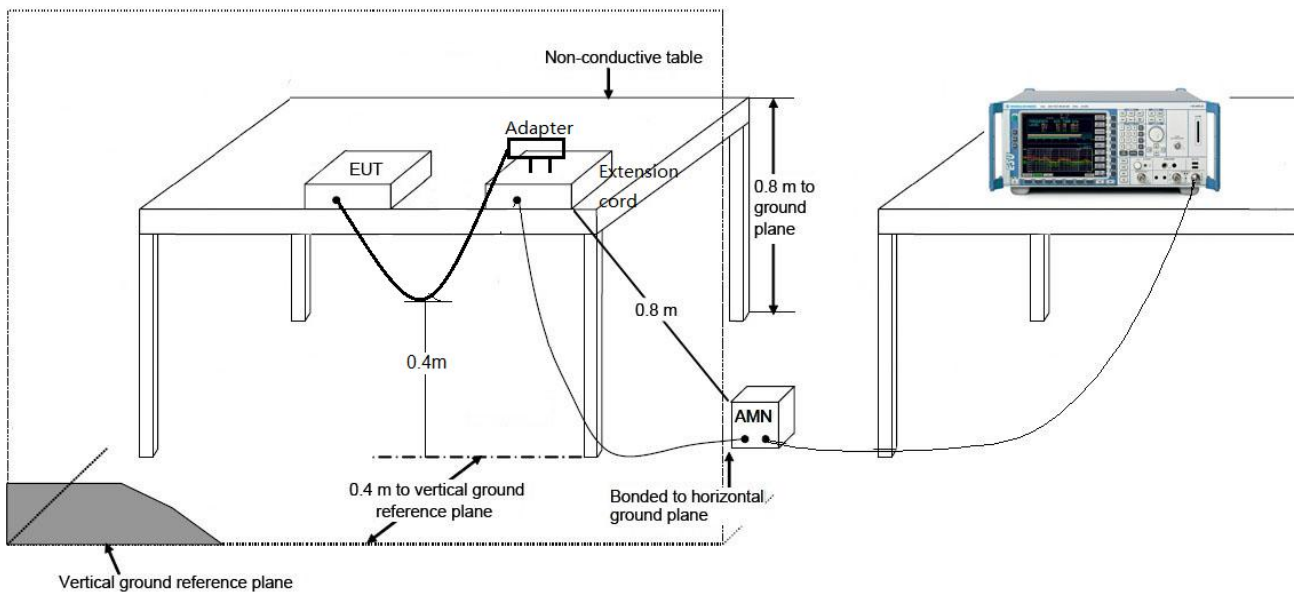

7.5.3. Test Result

The EUT is powered by DC source, so this requirement does not apply.

8. CONCLUSION

The data collected relate only the item(s) tested and show that the **IWISE DT 25M ACT&GL, US** is in compliance with Part 15C of the FCC Rules and ISED Rules.

The End

Appendix A – Test Setup Photograph

Refer to “1808RSU015-UT” file.

Appendix B – EUT Photograph

Refer to “1808RSU015-UE” file.