



FCC TEST REPORT (15.407)

REPORT NO.: RF120406C19-1

MODEL NO.: GT-WS100TX

FCC ID: JCK28T0HWS1001

RECEIVED: Nov. 14, 2011

TESTED: Nov. 15 ~ Nov. 18, 2011

ISSUED: Apr. 19, 2012

APPLICANT: GIGA-BYTE TECHNOLOGY CO., LTD.

ADDRESS: No.6, Bao Chiang Road, Hsin-Tien Dist., New Taipei City 231, Taiwan

ISSUED BY: Bureau Veritas Consumer Products Services (H.K.) Ltd., Taoyuan Branch

LAB ADDRESS: No. 47, 14th Ling, Chia Pau Vil., Lin Kou Dist., New Taipei City, Taiwan (R.O.C.)

TEST LOCATION: No. 19, Hwa Ya 2nd Rd, Wen Hwa Tsuen, Kwei Shan Hsiang, Taoyuan Hsien 333, Taiwan, R.O.C.

This test report consists of 41 pages in total. It may be duplicated completely for legal use with the approval of the applicant. It should not be reproduced except in full, without the written approval of our laboratory. The client should not use it to claim product, certification, approval or endorsement by TAF or any government agency. The test results in the report only apply to the tested sample.



TABLE OF CONTENTS

RELEASE CONTROL RECORD	4
1. CERTIFICATION.....	5
2. SUMMARY OF TEST RESULTS	6
2.1 MEASUREMENT UNCERTAINTY	6
3. GENERAL INFORMATION.....	7
3.1 GENERAL DESCRIPTION OF EUT	7
3.2 DESCRIPTION OF TEST MODES	8
3.2.1 CONFIGURATION OF SYSTEM UNDER TEST	8
3.2.2 DESCRIPTION OF SUPPORT UNITS	8
3.2.3 TEST MODE APPLICABILITY AND TESTED CHANNEL DETAIL	9
3.3 GENERAL DESCRIPTION OF APPLIED STANDARDS	10
4. TEST TYPES AND RESULTS	11
4.1 RADIATED EMISSION AND BANDEDGE MEASUREMENT	11
4.1.1 LIMITS OF RADIATED EMISSION AND BANDEDGE MEASUREMENT	11
4.1.2 LIMITS OF UNWANTED EMISSION OUT OF THE RESTRICTED BANDS	11
4.1.3 TEST INSTRUMENTS.....	12
4.1.4 TEST PROCEDURES	13
4.1.5 DEVIATION FROM TEST STANDARD.....	13
4.1.6 TEST SETUP.....	14
4.1.7 EUT OPERATING CONDITION.....	14
4.1.8 TEST RESULTS	15
4.2 CONDUCTED EMISSION MEASUREMENT	21
4.2.1 LIMITS OF CONDUCTED EMISSION MEASUREMENT	21
4.2.2 TEST INSTRUMENTS.....	21
4.2.3 TEST PROCEDURES	22
4.2.4 DEVIATION FROM TEST STANDARD.....	22
4.2.5 TEST SETUP	23
4.2.6 EUT OPERATING CONDITIONS	23
4.2.7 TEST RESULTS	24
4.3 MAXIMUM CONDUCTED OUTPUT POWER MEASUREMENT	26
4.3.1 LIMITS OF MAXIMUM CONDUCTED OUTPUT POWER MEASUREMENT.....	26
4.3.2 TEST SETUP.....	26
4.3.3 TEST INSTRUMENTS.....	26
4.3.4 TEST PROCEDURE.....	27
4.3.5 DEVIATION FROM TEST STANDARD.....	27
4.3.6 EUT OPERATING CONDITIONS	27
4.3.7 TEST RESULTS	28



A D T

4.4	PEAK POWER EXCURSION MEASUREMENT	29
4.4.1	LIMITS OF PEAK POWER EXCURSION MEASUREMENT	29
4.4.2	TEST SETUP	29
4.4.3	TEST INSTRUMENTS.....	29
4.4.4	TEST PROCEDURE.....	29
4.4.5	DEVIATION FROM TEST STANDARD.....	29
4.4.6	EUT OPERATING CONDITIONS	29
4.4.7	TEST RESULTS	30
4.5	PEAK POWER SPECTRAL DENSITY MEASUREMENT	34
4.5.1	LIMITS OF PEAK POWER SPECTRAL DENSITY MEASUREMENT	34
4.5.2	TEST SETUP	34
4.5.3	TEST INSTRUMENTS.....	34
4.5.4	TEST PROCEDURES	34
4.5.5	DEVIATION FROM TEST STANDARD.....	34
4.5.6	EUT OPERATING CONDITIONS	34
4.5.7	TEST RESULTS	35
4.6	FREQUENCY STABILITY.....	36
4.6.1	LIMITS OF FREQUENCY STABILITY MEASUREMENT	36
4.6.2	TEST SETUP	36
4.6.3	TEST INSTRUMENTS.....	36
4.6.4	TEST PROCEDURE.....	37
4.6.5	DEVIATION FROM TEST STANDARD.....	37
4.6.6	EUT OPERATING CONDITION.....	37
4.6.7	TEST RESULTS	38
5.	PHOTOGRAPHS OF THE TEST CONFIGURATION.....	39
6.	INFORMATION ON THE TESTING LABORATORIES	40
7.	APPENDIX A - MODIFICATIONS RECORDERS FOR ENGINEERING CHANGES TO THE EUT BY THE LAB.....	41



A D T

RELEASE CONTROL RECORD

ISSUE NO.	REASON FOR CHANGE	DATE ISSUED
RF120406C19-1	Original release	Apr. 19, 2012



1. CERTIFICATION

PRODUCT: SkyVision WS100
MODEL: GT-WS100TX
BRAND: Gigabyte
APPLICANT: GIGA-BYTE TECHNOLOGY CO., LTD.
TESTED: Nov. 15 ~ Nov. 18, 2011
TEST SAMPLE: ENGINEERING SAMPLE
STANDARDS: **FCC Part 15, Subpart E (Section 15.407)**
ANSI C63.10-2009

The above equipment (Model: GT-WS100TX) has been tested by **Bureau Veritas Consumer Products Services (H.K.) Ltd., Taoyuan Branch**, and found compliance with the requirement of the above standards. The test record, data evaluation & Equipment Under Test (EUT) configurations represented herein are true and accurate accounts of the measurements of the sample's EMC characteristics under the conditions specified in this report.

PREPARED BY :  , **DATE:** Apr. 19, 2012
Polly Chien / Specialist

APPROVED BY :  , **DATE:** Apr. 19, 2012
Gary Chang / Technical Manager

2. SUMMARY OF TEST RESULTS

The EUT has been tested according to the following specifications:

APPLIED STANDARD: FCC PART 15, SUBPART E (SECTION 15.407)			
STANDARD SECTION	TEST TYPE AND LIMIT	RESULT	REMARK
15.407(b)(5)	AC Power Conducted Emission	PASS	Meet the requirement of limit. Minimum passing margin is -6.84dB at 0.150MHz.
15.407(b)(1/2/3)(b)(5)	Electric Field Strength Spurious Emissions, 30MHz ~ 40000MHz	PASS	Meet the requirement of limit. Minimum passing margin is -8.2dB at 10460.00MHz
15.407(a)(1/2/3)	Peak Transmit Power	PASS	Meet the requirement of limit.
15.407(a)(6)	Peak Power Excursion	PASS	Meet the requirement of limit.
15.407(a)(1/2/3)	Peak Power Spectral Density	PASS	Meet the requirement of limit.
15.407(g)	Frequency Stability	PASS	Meet the requirement of limit.
15.203	Antenna Requirement	PASS	No antenna connector is used.

2.1 MEASUREMENT UNCERTAINTY

Where relevant, the following measurement uncertainty levels have been estimated for tests performed on the EUT as specified in CISPR 16-4-2:

MEASUREMENT	FREQUENCY	UNCERTAINTY
Conducted emissions	150kHz~30MHz	2.44 dB
Radiated emissions	30MHz ~ 200MHz	3.19 dB
	200MHz ~1000MHz	3.21 dB
	1GHz ~ 18GHz	2.26 dB
	18GHz ~ 40GHz	1.94 dB

This uncertainty represents an expanded uncertainty expressed at approximately the 95% confidence level using a coverage factor of $k = 2$.

3. GENERAL INFORMATION

3.1 GENERAL DESCRIPTION OF EUT

EUT	SkyVision WS100
MODEL NO.	GT-WS100TX
POWER SUPPLY	5Vdc (Host equipment)
MODULATION TECHNOLOGY	OFDM
MODULATION TYPE	OOK
TRANSFER RATE	Downlink: 1Mbps Uplink: 100Kbps
OPERATING FREQUENCY	5180.0 ~ 5240.0MHz
NUMBER OF CHANNEL	4 for channel bandwidth (20MHz) 2 for channel bandwidth (40MHz)
OUTPUT POWER	4.0mW
ANTENNA TYPE	PCB antenna with 2dBi gain
ANTENNA CONNECTOR	NA
DATA CABLE	0.2m shielded USB cable without core (for power supply)
I/O PORTS	Refer to user's manual
ACCESSORY DEVICES	NA

NOTE:

1. The EUT incorporates a MIMO function. Physically, the EUT provides two completed transmitters and one receiver.

MODULATION MODE	TX FUNCTION
Channel bandwidth (20MHz)	2TX
Channel bandwidth (40MHz)	2TX

2. The above EUT information is declared by manufacturer and for more detailed features description, please refer to the manufacturer's specifications or user's manual.

3.2 DESCRIPTION OF TEST MODES

4 channels are provided for channel bandwidth (20MHz):

FREQUENCY	FREQUENCY
5180MHz	5220MHz
5200MHz	5240MHz

2 channels are provided for channel bandwidth (40MHz):

FREQUENCY	FREQUENCY
5190MHz	5230MHz

3.2.1 CONFIGURATION OF SYSTEM UNDER TEST

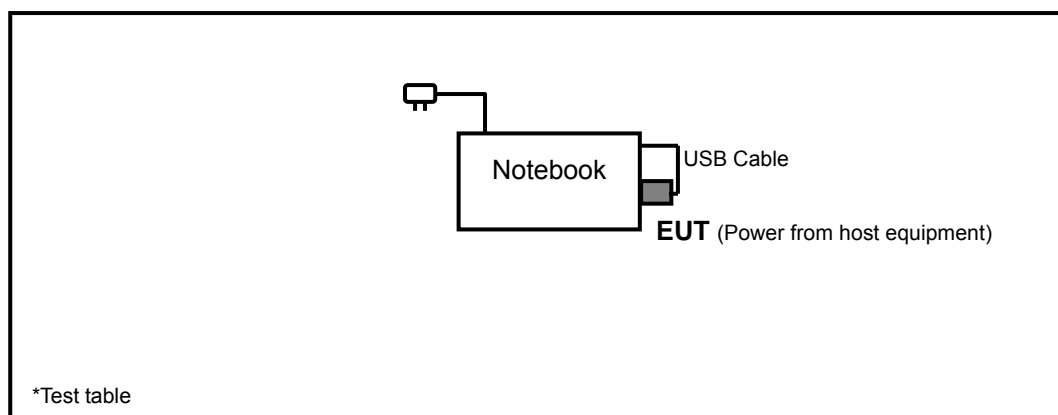

3.2.2 DESCRIPTION OF SUPPORT UNITS

The EUT has been tested as an independent unit together with other necessary accessories or support units. The following support units or accessories were used to form a representative test configuration during the tests.

NO.	PRODUCT	BRAND	MODEL NO.	SERIAL NO.	FCC ID
1	NOTEBOOK	DELL	E5520	8Y4DMQ1	NA

NO.	SIGNAL CABLE DESCRIPTION OF THE ABOVE SUPPORT UNITS
1	NA

NOTE: All power cords of the above support units are non shielded (1.8m).

3.2.3 TEST MODE APPLICABILITY AND TESTED CHANNEL DETAIL

EUT CONFIGURE MODE	APPLICABLE TO				DESCRIPTION
	RE≥1G	RE<1G	PLC	APCM	
-	√	√	√	√	-

Where **RE≥1G**: Radiated Emission above 1GHz **RE<1G**: Radiated Emission below 1GHz
PLC: Power Line Conducted Emission **APCM**: Antenna Port Conducted Measurement

RADIATED EMISSION TEST (ABOVE 1GHz):

- Pre-Scan has been conducted to determine the worst-case mode from all possible combinations between available modulations, data rates and antenna ports (if EUT with antenna diversity architecture).
- Following frequency (frequencies) was (were) selected for the final test as listed below.

EUT CONFIGURE MODE	MODE	AVAILABLE FREQUENCY	TESTED FREQUENCY	MODULATION TECHNOLOGY	MODULATION TYPE	DATA RATE (Kbps)
-	channel bandwidth (20MHz)	5180 to 5240	5180, 5200, 5240	OFDM	OOK	100
-	channel bandwidth (40MHz)	5190 to 5230	5190, 5230	OFDM	OOK	100

RADIATED EMISSION TEST (BELOW 1GHz):

- Pre-Scan has been conducted to determine the worst-case mode from all possible combinations between available modulations, data rates and antenna ports (if EUT with antenna diversity architecture).
- Following frequency (frequencies) was (were) selected for the final test as listed below.

EUT CONFIGURE MODE	MODE	AVAILABLE FREQUENCY	TESTED FREQUENCY	MODULATION TECHNOLOGY	MODULATION TYPE	DATA RATE (Kbps)
-	channel bandwidth (20MHz)	5180 to 5240	5180	OFDM	OOK	100

POWER LINE CONDUCTED EMISSION TEST:

- Pre-Scan has been conducted to determine the worst-case mode from all possible combinations between available modulations, data rates and antenna ports (if EUT with antenna diversity architecture).
- Following frequency (frequencies) was (were) selected for the final test as listed below.

EUT CONFIGURE MODE	MODE	AVAILABLE FREQUENCY	TESTED FREQUENCY	MODULATION TECHNOLOGY	MODULATION TYPE	DATA RATE (Kbps)
-	channel bandwidth (20MHz)	5180 to 5240	5180	OFDM	OOK	100

ANTENNA PORT CONDUCTED MEASUREMENT:

- Pre-Scan has been conducted to determine the worst-case mode from all possible combinations between available modulations, data rates and antenna ports (if EUT with antenna diversity architecture).
- Following frequency (frequencies) was (were) selected for the final test as listed below.

EUT CONFIGURE MODE	MODE	AVAILABLE FREQUENCY	TESTED FREQUENCY	MODULATION TECHNOLOGY	MODULATION TYPE	DATA RATE (Kbps)
-	channel bandwidth (20MHz)	5180 to 5240	5180, 5200, 5240	OFDM	OOK	100
-	channel bandwidth (40MHz)	5190 to 5230	5190, 5230	OFDM	OOK	100

TEST CONDITION:

APPLICABLE TO	ENVIRONMENTAL CONDITIONS	INPUT POWER (SYSTEM)	TESTED BY
RE \geq 1G	25deg. C, 65%RH	120Vac, 60Hz	Kay Wu
RE<1G	25deg. C, 65%RH	120Vac, 60Hz	Kay Wu
PLC	25deg. C, 63%RH	120Vac, 60Hz	Scott Yang
APCM	25deg. C, 65%RH	120Vac, 60Hz	Kay Wu

3.3 GENERAL DESCRIPTION OF APPLIED STANDARDS

The EUT is a RF Product. According to the specifications of the manufacturer, it must comply with the requirements of the following standards:

FCC Part 15, Subpart E (15.407)

ANSI C63.10-2009

All test items have been performed and recorded as per the above standards.

NOTE: The EUT is also considered as a kind of computer peripheral, because the connection to computer is necessary for typical use. It has been verified to comply with the requirements of FCC Part 15, Subpart B, Class B (DoC). The test report has been issued separately.

4. TEST TYPES AND RESULTS

4.1 RADIATED EMISSION AND BANDEDGE MEASUREMENT

4.1.1 LIMITS OF RADIATED EMISSION AND BANDEDGE MEASUREMENT

Emissions radiated outside of the specified bands, shall be according to the general radiated limits in 15.209 as following:

FREQUENCIES (MHz)	FIELD STRENGTH (microvolts/meter)	MEASUREMENT DISTANCE (meters)
0.009 ~ 0.490	2400/F(kHz)	300
0.490 ~ 1.705	24000/F(kHz)	30
1.705 ~ 30.0	30	30
30 ~ 88	100	3
88 ~ 216	150	3
216 ~ 960	200	3
Above 960	500	3

NOTE:

1. The lower limit shall apply at the transition frequencies.
2. Emission level (dBuV/m) = 20 log Emission level (uV/m).
3. As shown in 15.35(b), for frequencies above 1000MHz, the field strength limits are based on average detector, however, the peak field strength of any emission shall not exceed the maximum permitted average limits, specified above by more than 20dB under any condition of modulation.

4.1.2 LIMITS OF UNWANTED EMISSION OUT OF THE RESTRICTED BANDS

FREQUENCIES (MHz)	EIRP LIMIT (dBm)	EQUIVALENT FIELD STRENGTH AT 3m (dBµV/m) *NOTE 3
	PK	PK
5150 ~ 5250	-27	68.3

NOTE: The following formula is used to convert the equipment isotropic radiated power (eirp) to field strength:

$$E = \frac{1000000\sqrt{30P}}{3} \mu\text{V/m, where P is the eirp (Watts).}$$

4.1.3 TEST INSTRUMENTS

DESCRIPTION & MANUFACTURER	MODEL NO.	SERIAL NO.	DATE OF CALIBRATION	DUE DATE OF CALIBRATION
Test Receiver ROHDE & SCHWARZ	ESIB7	100212	Aug. 02, 2011	Aug. 01, 2012
Spectrum Analyzer ROHDE & SCHWARZ	FSP 40	100041	Jul. 21, 2011	Jul. 20, 2012
BILOG Antenna SCHWARZBECK	VULB9168	9168-160	Apr. 13, 2011	Apr. 12, 2012
HORN Antenna SCHWARZBECK	9120D	209	Aug. 25, 2011	Aug. 24, 2012
HORN Antenna SCHWARZBECK	BBHA 9170	BBHA9170243	Dec. 27, 2010	Dec. 26, 2011
Preamplifier Agilent	8447D	2944A10633	Oct. 29, 2011	Oct. 28, 2012
Preamplifier Agilent	8449B	3008A01964	Oct. 29, 2011	Oct. 28, 2012
RF signal cable HUBER+SUHNNER	SUCOFLEX 104	295014/4	Aug. 19, 2011	Aug. 18, 2012
RF signal cable HUBER+SUHNNER	SUCOFLEX 104	12738/6	Aug. 19, 2011	Aug. 18, 2012
Software ADT.	ADT_Radiated_ V7.6.15.9.2	NA	NA	NA
Antenna Tower inn-co GmbH	MA 4000	013303	NA	NA
Antenna Tower Controller inn-co GmbH	CO2000	017303	NA	NA
Turn Table ADT.	TT100.	TT93021703	NA	NA
Turn Table Controller ADT.	SC100.	SC93021703	NA	NA
26GHz ~ 40GHz Amplifier	EM26400	815221	Oct. 29, 2011	Oct. 28, 2012
High Speed Peak Power Meter	ML2495A	0842014	Apr. 26, 2011	Apr. 25, 2012
Power Sensor	MA2411B	0738404	Apr. 26, 2011	Apr. 25, 2012

- NOTE:** 1. The calibration interval of the above test instruments is 12 months and the calibrations are traceable to NML/ROC and NIST/USA.
2. The test was performed in HwaYa Chamber 3.
3. The horn antenna and HP preamplifier (model: 8449B) are used only for the measurement of emission frequency above 1GHz if tested.
4. The FCC Site Registration No. is 988962.
5. The IC Site Registration No. is IC7450F-3.

4.1.4 TEST PROCEDURES

- a. The EUT was placed on the top of a rotating table 0.8 meters above the ground at a 3 meter semi-anechoic chamber. The table was rotated 360 degrees to determine the position of the highest radiation.
- b. The EUT was set 3 meters away from the interference-receiving antenna, which was mounted on the top of a variable-height antenna tower.
- c. The antenna is a broadband antenna, and its height is varied from one meter to four meters above the ground to determine the maximum value of the field strength. Both horizontal and vertical polarizations of the antenna are set to make the measurement.
- d. For each suspected emission, the EUT was arranged to its worst case and then the antenna was tuned to heights from 1 meter to 4 meters and the rotatable table was turned from 0 degrees to 360 degrees to find the maximum reading.
- e. The test-receiver system was set to Peak Detect Function and Specified Bandwidth with Maximum Hold Mode.
- f. If the emission level of the EUT in peak mode was 10dB lower than the limit specified, then testing could be stopped and the peak values of the EUT would be reported. Otherwise the emissions that did not have 10dB margin would be re-tested one by one using peak, quasi-peak or average method as specified and then reported in a data sheet.

NOTE:

1. The resolution bandwidth and video bandwidth of test receiver/spectrum analyzer is 120kHz for Peak detection (PK) and Quasi-peak detection (QP) at frequency below 1GHz.
2. The resolution bandwidth of test receiver/spectrum analyzer is 1MHz and video bandwidth is 3MHz for Peak detection at frequency above 1GHz.
3. The resolution bandwidth of test receiver/spectrum analyzer is 1MHz and the video bandwidth is 1kHz for Average detection (AV) at frequency above 1GHz.
4. All modes of operation were investigated and the worst-case emissions are reported.

4.1.5 DEVIATION FROM TEST STANDARD

No deviation.

4.1.6 TEST SETUP

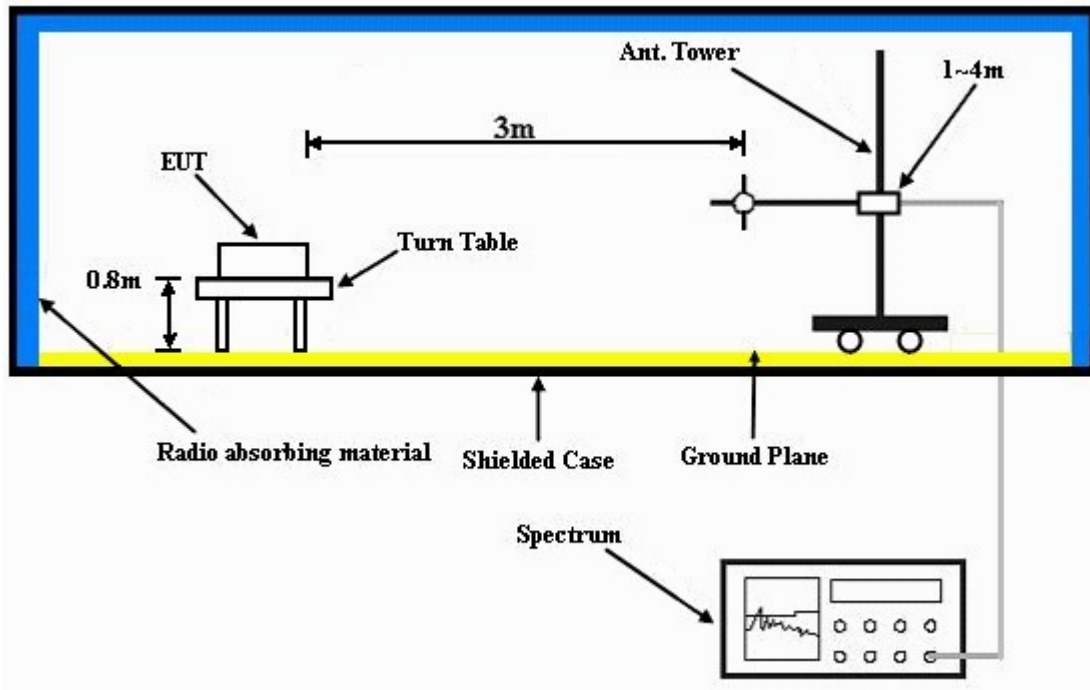

For the actual test configuration, please refer to the attached file (Test Setup Photo).

4.1.7 EUT OPERATING CONDITION

- a. Plugged the EUT to notebook.
- b. Set the EUT under transmitting condition continuously at specific channel frequency.

4.1.8 TEST RESULTS

ABOVE 1GHz DATA

Channel Bandwidth (20MHz)

EUT TEST CONDITION		MEASUREMENT DETAIL	
FREQUENCY	5180	FREQUENCY RANGE	1 ~ 40GHz
INPUT POWER (SYSTEM)	120Vac, 60 Hz	DETECTOR FUNCTION	Peak (PK) Average (AV)
ENVIRONMENTAL CONDITIONS	25deg. C, 65%RH	TESTED BY	Kay Wu

ANTENNA POLARITY & TEST DISTANCE: HORIZONTAL AT 3 M								
NO.	FREQ. (MHz)	EMISSION LEVEL (dBuV/m)	LIMIT (dBuV/m)	MARGIN (dB)	ANTENNA HEIGHT (m)	TABLE ANGLE (Degree)	RAW VALUE (dBuV)	CORRECTION FACTOR (dB/m)
1	5150.00	47.0 PK	74.0	-27.0	1.02 H	300	9.50	37.50
2	5150.00	30.4 AV	54.0	-23.6	1.02 H	300	-7.10	37.50
3	*5180.00	98.7 PK			1.02 H	300	61.20	37.50
4	*5180.00	82.1 AV			1.02 H	300	44.60	37.50
5	#10360.00	59.3 PK	68.3	-9.0	1.71 H	348	11.00	48.30
ANTENNA POLARITY & TEST DISTANCE: VERTICAL AT 3 M								
NO.	FREQ. (MHz)	EMISSION LEVEL (dBuV/m)	LIMIT (dBuV/m)	MARGIN (dB)	ANTENNA HEIGHT (m)	TABLE ANGLE (Degree)	RAW VALUE (dBuV)	CORRECTION FACTOR (dB/m)
1	5150.00	44.1 PK	74.0	-29.9	1.00 V	40	6.60	37.50
2	5150.00	30.3 AV	54.0	-23.7	1.00 V	40	-7.20	37.50
3	*5180.00	98.4 PK			1.00 V	40	60.90	37.50
4	*5180.00	81.7 AV			1.00 V	40	44.20	37.50
5	#10360.00	55.6 PK	68.3	-12.7	1.00 V	360	7.30	48.30

- REMARKS:**
1. Emission level (dBuV/m) = Raw Value (dBuV) + Correction Factor (dB/m).
 2. Correction Factor (dB/m) = Antenna Factor (dB/m) + Cable Factor (dB).
 3. The other emission levels were very low against the limit.
 4. Margin value = Emission level – Limit value.
 5. “ * “: Fundamental frequency.
 6. “#“: The radiated frequency is out the restricted band.



A D T

EUT TEST CONDITION		MEASUREMENT DETAIL	
FREQUENCY	5200	FREQUENCY RANGE	1 ~ 40GHz
INPUT POWER (SYSTEM)	120Vac, 60 Hz	DETECTOR FUNCTION	Peak (PK) Average (AV)
ENVIRONMENTAL CONDITIONS	25deg. C, 65%RH	TESTED BY	Kay Wu

ANTENNA POLARITY & TEST DISTANCE: HORIZONTAL AT 3 M								
NO.	FREQ. (MHz)	EMISSION LEVEL (dBuV/m)	LIMIT (dBuV/m)	MARGIN (dB)	ANTENNA HEIGHT (m)	TABLE ANGLE (Degree)	RAW VALUE (dBuV)	CORRECTION FACTOR (dB/m)
1	*5200.00	98.9 PK			1.02 H	298	61.40	37.50
2	*5200.00	81.8 AV			1.02 H	298	44.30	37.50
3	#10400.00	59.4 PK	68.3	-8.9	1.70 H	351	11.00	48.40
4	15600.00	56.5 PK	74.0	-17.5	1.00 H	10	8.00	48.50
5	15600.00	42.2 AV	54.0	-11.8	1.00 H	10	-6.30	48.50
ANTENNA POLARITY & TEST DISTANCE: VERTICAL AT 3 M								
NO.	FREQ. (MHz)	EMISSION LEVEL (dBuV/m)	LIMIT (dBuV/m)	MARGIN (dB)	ANTENNA HEIGHT (m)	TABLE ANGLE (Degree)	RAW VALUE (dBuV)	CORRECTION FACTOR (dB/m)
1	*5200.00	98.4 PK			1.00 V	42	60.90	37.50
2	*5200.00	81.5 AV			1.00 V	42	44.00	37.50
3	#10400.00	57.3 PK	68.3	-11.0	1.00 V	44	8.90	48.40
4	15600.00	56.2 PK	74.0	-17.8	1.00 V	20	7.70	48.50
5	15600.00	42.5 AV	54.0	-11.5	1.00 V	20	-6.00	48.50

- REMARKS:**
1. Emission level (dBuV/m) = Raw Value (dBuV) + Correction Factor (dB/m).
 2. Correction Factor (dB/m) = Antenna Factor (dB/m) + Cable Factor (dB).
 3. The other emission levels were very low against the limit.
 4. Margin value = Emission level – Limit value.
 5. “ * “: Fundamental frequency.
 6. “#”:The radiated frequency is out the restricted band.



A D T

EUT TEST CONDITION		MEASUREMENT DETAIL	
FREQUENCY	5240	FREQUENCY RANGE	1 ~ 40GHz
INPUT POWER (SYSTEM)	120Vac, 60 Hz	DETECTOR FUNCTION	Peak (PK) Average (AV)
ENVIRONMENTAL CONDITIONS	25deg. C, 65%RH	TESTED BY	Kay Wu

ANTENNA POLARITY & TEST DISTANCE: HORIZONTAL AT 3 M								
NO.	FREQ. (MHz)	EMISSION LEVEL (dBuV/m)	LIMIT (dBuV/m)	MARGIN (dB)	ANTENNA HEIGHT (m)	TABLE ANGLE (Degree)	RAW VALUE (dBuV)	CORRECTION FACTOR (dB/m)
1	*5240.00	98.5 PK			1.00 H	34	60.90	37.60
2	*5240.00	81.5 AV			1.00 H	34	43.90	37.60
3	5350.00	45.0 PK	74.0	-29.0	1.00 H	34	7.20	37.80
4	5350.00	30.9 AV	54.0	-23.1	1.00 H	34	-6.90	37.80
5	#10480.00	56.9 PK	68.3	-11.4	1.00 H	36	8.40	48.50
ANTENNA POLARITY & TEST DISTANCE: VERTICAL AT 3 M								
NO.	FREQ. (MHz)	EMISSION LEVEL (dBuV/m)	LIMIT (dBuV/m)	MARGIN (dB)	ANTENNA HEIGHT (m)	TABLE ANGLE (Degree)	RAW VALUE (dBuV)	CORRECTION FACTOR (dB/m)
1	*5240.00	98.0 PK			1.01 V	300	60.40	37.60
2	*5240.00	81.1 AV			1.01 V	300	43.50	37.60
3	5350.00	45.1 PK	74.0	-28.9	1.01 V	300	7.30	37.80
4	5350.00	31.0 AV	54.0	-23.0	1.01 V	300	-6.80	37.80
5	#10480.00	58.7 PK	68.3	-9.6	1.67 V	346	10.20	48.50

- REMARKS:**
1. Emission level (dBuV/m) = Raw Value (dBuV) + Correction Factor (dB/m).
 2. Correction Factor (dB/m) = Antenna Factor (dB/m) + Cable Factor (dB).
 3. The other emission levels were very low against the limit.
 4. Margin value = Emission level – Limit value.
 5. “ * “: Fundamental frequency.
 6. “#”:The radiated frequency is out the restricted band.



A D T

Channel Bandwidth (40MHz)

EUT TEST CONDITION		MEASUREMENT DETAIL	
FREQUENCY	5190	FREQUENCY RANGE	1 ~ 40GHz
INPUT POWER (SYSTEM)	120Vac, 60 Hz	DETECTOR FUNCTION	Peak (PK) Average (AV)
ENVIRONMENTAL CONDITIONS	25deg. C, 65%RH	TESTED BY	Kay Wu

ANTENNA POLARITY & TEST DISTANCE: HORIZONTAL AT 3 M								
NO.	FREQ. (MHz)	EMISSION LEVEL (dBuV/m)	LIMIT (dBuV/m)	MARGIN (dB)	ANTENNA HEIGHT (m)	TABLE ANGLE (Degree)	RAW VALUE (dBuV)	CORRECTION FACTOR (dB/m)
1	5150.00	44.4 PK	74.0	-29.6	1.00 H	42	6.90	37.50
2	5150.00	31.3 AV	54.0	-22.7	1.00 H	42	-6.20	37.50
3	*5190.00	95.6 PK			1.00 H	42	58.10	37.50
4	*5190.00	80.1 AV			1.00 H	42	42.60	37.50
5	#10380.00	57.0 PK	68.3	-11.3	1.63 H	51	8.70	48.30
ANTENNA POLARITY & TEST DISTANCE: VERTICAL AT 3 M								
NO.	FREQ. (MHz)	EMISSION LEVEL (dBuV/m)	LIMIT (dBuV/m)	MARGIN (dB)	ANTENNA HEIGHT (m)	TABLE ANGLE (Degree)	RAW VALUE (dBuV)	CORRECTION FACTOR (dB/m)
1	5150.00	44.5 PK	74.0	-29.5	1.03 V	299	7.00	37.50
2	5150.00	31.4 AV	54.0	-22.6	1.03 V	299	-6.10	37.50
3	*5190.00	95.2 PK			1.03 V	299	57.70	37.50
4	*5190.00	79.8 AV			1.03 V	299	42.30	37.50
5	#10380.00	59.3 PK	68.3	-9.0	1.84 V	348	11.00	48.30

- REMARKS:**
1. Emission level (dBuV/m) = Raw Value (dBuV) + Correction Factor (dB/m).
 2. Correction Factor (dB/m) = Antenna Factor (dB/m) + Cable Factor (dB).
 3. The other emission levels were very low against the limit.
 4. Margin value = Emission level – Limit value.
 5. “ * “: Fundamental frequency.
 6. “#”: The radiated frequency is out the restricted band.



EUT TEST CONDITION		MEASUREMENT DETAIL	
FREQUENCY	5230	FREQUENCY RANGE	1 ~ 40GHz
INPUT POWER (SYSTEM)	120Vac, 60 Hz	DETECTOR FUNCTION	Peak (PK) Average (AV)
ENVIRONMENTAL CONDITIONS	25deg. C, 65%RH	TESTED BY	Kay Wu

ANTENNA POLARITY & TEST DISTANCE: HORIZONTAL AT 3 M								
NO.	FREQ. (MHz)	EMISSION LEVEL (dBuV/m)	LIMIT (dBuV/m)	MARGIN (dB)	ANTENNA HEIGHT (m)	TABLE ANGLE (Degree)	RAW VALUE (dBuV)	CORRECTION FACTOR (dB/m)
1	*5230.00	94.3 PK			1.00 H	34	56.70	37.60
2	*5230.00	79.8 AV			1.00 H	34	42.20	37.60
3	5350.00	44.3 PK	74.0	-29.7	1.00 H	34	6.50	37.80
4	5350.00	30.8 AV	54.0	-23.2	1.00 H	34	-7.00	37.80
5	#10460.00	56.7 PK	68.3	-11.6	1.43 H	71	8.20	48.50
ANTENNA POLARITY & TEST DISTANCE: VERTICAL AT 3 M								
NO.	FREQ. (MHz)	EMISSION LEVEL (dBuV/m)	LIMIT (dBuV/m)	MARGIN (dB)	ANTENNA HEIGHT (m)	TABLE ANGLE (Degree)	RAW VALUE (dBuV)	CORRECTION FACTOR (dB/m)
1	*5230.00	93.7 PK			1.01 V	298	56.10	37.60
2	*5230.00	79.1 AV			1.01 V	298	41.50	37.60
3	5350.00	44.8 PK	74.0	-29.2	1.01 V	298	7.00	37.80
4	5350.00	30.7 AV	54.0	-23.3	1.01 V	298	-7.10	37.80
5	#10460.00	60.1 PK	68.3	-8.2	1.70 V	346	11.60	48.50

- REMARKS:**
1. Emission level (dBuV/m) = Raw Value (dBuV) + Correction Factor (dB/m).
 2. Correction Factor (dB/m) = Antenna Factor (dB/m) + Cable Factor (dB).
 3. The other emission levels were very low against the limit.
 4. Margin value = Emission level – Limit value.
 5. “ * ”: Fundamental frequency.
 6. "#":The radiated frequency is out the restricted band.

BELOW 1GHz WORST-CASE DATA : Channel Bandwidth (20MHz)

EUT TEST CONDITION		MEASUREMENT DETAIL	
FREQUENCY	5180	FREQUENCY RANGE	Below 1000MHz
INPUT POWER (SYSTEM)	120Vac, 60 Hz	DETECTOR FUNCTION	Quasi-Peak
ENVIRONMENTAL CONDITIONS	25deg. C, 65%RH	TESTED BY	Kay Wu

ANTENNA POLARITY & TEST DISTANCE: HORIZONTAL AT 3 M								
NO.	FREQ. (MHz)	EMISSION LEVEL (dBuV/m)	LIMIT (dBuV/m)	MARGIN (dB)	ANTENNA HEIGHT (m)	TABLE ANGLE (Degree)	RAW VALUE (dBuV)	CORRECTION FACTOR (dB/m)
1	45.45	14.8 QP	40.0	-25.2	1.50 H	175	0.40	14.40
2	144.61	16.2 QP	43.5	-27.3	1.00 H	187	1.90	14.30
3	216.55	11.4 QP	46.0	-34.6	1.50 H	100	0.20	11.20
4	432.37	18.1 QP	46.0	-27.9	1.00 H	187	-0.20	18.30
5	665.68	19.0 QP	46.0	-27.0	1.00 H	241	-4.50	23.50
6	852.33	19.1 QP	46.0	-26.9	2.00 H	190	-7.00	26.10

ANTENNA POLARITY & TEST DISTANCE: VERTICAL AT 3 M								
NO.	FREQ. (MHz)	EMISSION LEVEL (dBuV/m)	LIMIT (dBuV/m)	MARGIN (dB)	ANTENNA HEIGHT (m)	TABLE ANGLE (Degree)	RAW VALUE (dBuV)	CORRECTION FACTOR (dB/m)
1	29.90	10.3 QP	40.0	-29.7	1.00 V	184	-2.20	12.50
2	66.84	12.9 QP	40.0	-27.1	1.00 V	190	0.50	12.40
3	144.61	15.9 QP	43.5	-27.6	1.00 V	151	1.60	14.30
4	166.00	14.0 QP	43.5	-29.5	1.00 V	190	0.00	14.00
5	432.37	18.6 QP	46.0	-27.4	1.50 V	190	0.30	18.30
6	665.68	17.5 QP	46.0	-28.5	1.00 V	229	-6.00	23.50

- REMARKS:**
1. Emission level (dBuV/m) = Raw Value (dBuV) + Correction Factor (dB/m).
 2. Correction Factor (dB/m) = Antenna Factor (dB/m) + Cable Factor (dB).
 3. The other emission levels were very low against the limit.
 4. Margin value = Emission level – Limit value.

4.2 CONDUCTED EMISSION MEASUREMENT

4.2.1 LIMITS OF CONDUCTED EMISSION MEASUREMENT

FREQUENCY OF EMISSION (MHz)	CONDUCTED LIMIT (dB μ V)	
	Quasi-peak	Average
0.15 ~ 0.5	66 to 56	56 to 46
0.5 ~ 5	56	46
5 ~ 30	60	50

- NOTE:** 1. The lower limit shall apply at the transition frequencies.
2. The limit decreases in line with the logarithm of the frequency in the range of 0.15 to 0.50MHz.
3. All emanations from a class A/B digital device or system, including any network of conductors and apparatus connected thereto, shall not exceed the level of field strengths specified above.

4.2.2 TEST INSTRUMENTS

DESCRIPTION & MANUFACTURER	MODEL NO.	SERIAL NO.	DATE OF CALIBRATION	DUE DATE OF CALIBRATION
Test Receiver ROHDE & SCHWARZ	ESCS30	100291	Nov. 30, 2010	Nov. 29, 2011
RF signal cable Woken	5D-FB	Cable-HYC01-01	Dec. 30, 2010	Dec. 29, 2011
LISN ROHDE & SCHWARZ	ESH3-Z5	100312	Jul. 07, 2011	Jul. 06, 2012
LISN ROHDE & SCHWARZ	ESH3-Z5	835239/001	Feb. 22, 2011	Feb. 21, 2012
Software ADT	ADT_Cond_ V7.3.7	NA	NA	NA

- NOTE:** 1. The calibration interval of the above test instruments is 12 months and the calibrations are traceable to NML/ROC and NIST/USA.
2. The test was performed in HwaYa Shielded Room 1.
3. The VCCI Site Registration No. is C-2040.

4.2.3 TEST PROCEDURES

- a. The EUT was placed 0.4 meters from the conducting wall of the shielded room with EUT being connected to the power mains through a line impedance stabilization network (LISN). Other support units were connected to the power mains through another LISN. The two LISNs provide 50 ohm/ 50uH of coupling impedance for the measuring instrument.
- b. Both lines of the power mains connected to the EUT were checked for maximum conducted interference.
- c. The frequency range from 150kHz to 30MHz was searched. Emission levels under (Limit - 20dB) was not recorded.

NOTE: All modes of operation were investigated and the worst-case emissions are reported.

4.2.4 DEVIATION FROM TEST STANDARD

No deviation.

4.2.5 TEST SETUP

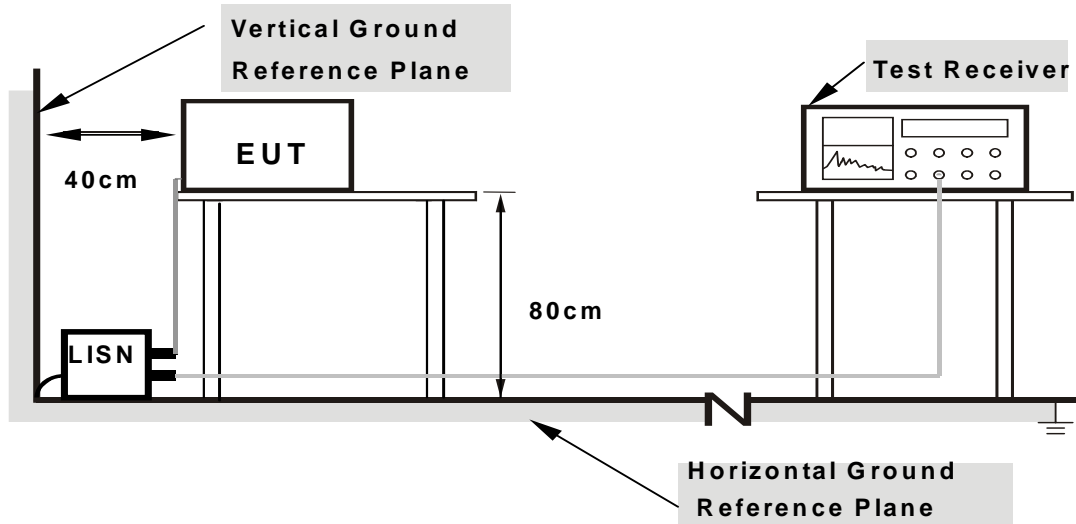

- Note:**
- 1.Support units were connected to second LISN.
 - 2.Both of LISNs (AMN) are 80 cm from EUT and at least 80 from other units and other metal planes

For the actual test configuration, please refer to the attached file (Test Setup Photo).

4.2.6 EUT OPERATING CONDITIONS

Same as 4.1.6.

4.2.7 TEST RESULTS

CONDUCTED WORST-CASE DATA :

PHASE	Line 1	6dB BANDWIDTH	9kHz
-------	--------	---------------	------

No	Freq. [MHz]	Corr. Factor (dB)	Reading Value		Emission Level		Limit		Margin	
			[dB (uV)]		[dB (uV)]		[dB (uV)]		(dB)	
			Q.P.	AV.	Q.P.	AV.	Q.P.	AV.	Q.P.	AV.
1	0.150	0.15	59.01	35.47	59.16	35.62	66.00	56.00	-6.84	-20.38
2	0.185	0.15	52.53	33.46	52.68	33.61	64.25	54.25	-11.57	-20.64
3	0.220	0.15	49.45	33.90	49.60	34.05	62.81	52.81	-13.21	-18.76
4	0.455	0.17	35.68	20.66	35.85	20.83	56.79	46.79	-20.94	-25.96
5	0.904	0.19	31.44	21.89	31.63	22.08	56.00	46.00	-24.37	-23.92
6	11.586	0.66	26.04	21.13	26.70	21.79	60.00	50.00	-33.30	-28.21

- REMARKS:**
1. Q.P. and AV. are abbreviations of quasi-peak and average individually.
 2. "-": The Quasi-peak reading value also meets average limit and measurement with the average detector is unnecessary.
 3. The emission levels of other frequencies were very low against the limit.
 4. Margin value = Emission level - Limit value
 5. Correction factor = Insertion loss + Cable loss
 6. Emission Level = Correction Factor + Reading Value.

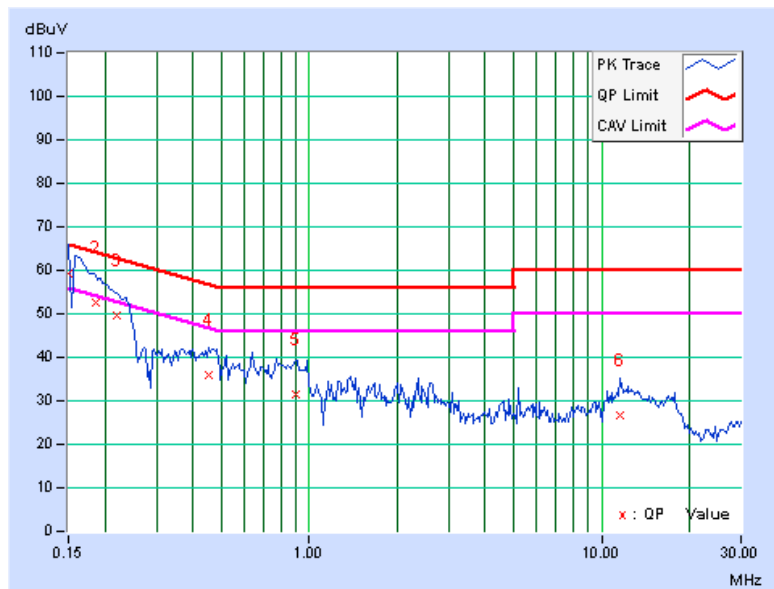

PHASE	Line 2	6dB BANDWIDTH	9kHz
-------	--------	---------------	------

No	Freq. [MHz]	Corr.	Reading Value		Emission Level		Limit		Margin	
		Factor (dB)	[dB (uV)]		[dB (uV)]		[dB (uV)]		(dB)	
	Q.P.	AV.	Q.P.	AV.	Q.P.	AV.	Q.P.	AV.	Q.P.	AV.
1	0.154	0.16	58.31	34.30	58.47	34.46	65.79	55.79	-7.32	-21.33
2	0.181	0.16	52.55	31.35	52.71	31.51	64.43	54.43	-11.71	-22.91
3	0.216	0.17	47.45	32.09	47.62	32.26	62.96	52.96	-15.33	-20.69
4	0.463	0.19	31.69	19.03	31.88	19.22	56.65	46.65	-24.77	-27.43
5	0.838	0.20	29.50	18.56	29.70	18.76	56.00	46.00	-26.30	-27.24
6	12.332	0.61	26.91	22.05	27.52	22.66	60.00	50.00	-32.48	-27.34

- REMARKS:**
1. Q.P. and AV. are abbreviations of quasi-peak and average individually.
 2. "-": The Quasi-peak reading value also meets average limit and measurement with the average detector is unnecessary.
 3. The emission levels of other frequencies were very low against the limit.
 4. Margin value = Emission level - Limit value
 5. Correction factor = Insertion loss + Cable loss
 6. Emission Level = Correction Factor + Reading Value.

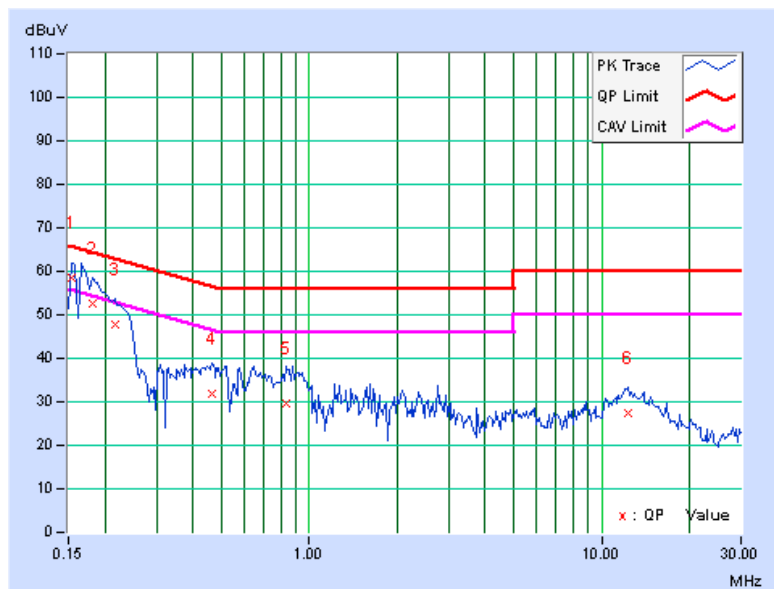

4.3 MAXIMUM CONDUCTED OUTPUT POWER MEASUREMENT

4.3.1 LIMITS OF MAXIMUM CONDUCTED OUTPUT POWER MEASUREMENT

FREQUENCY BAND	LIMIT
5.15 ~ 5.25GHz	The lesser of 50mW (17dBm) or 4dBm + 10logB

NOTE: Where B is the 26dB emission bandwidth in MHz.

4.3.2 TEST SETUP

FOR POWER OUTPUT MEASUREMENT

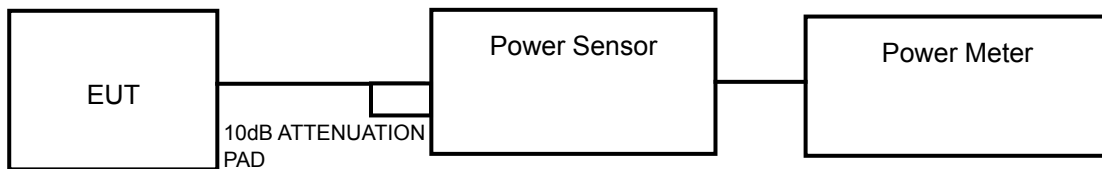

FOR 26dB OCCUPIED BANDWIDTH

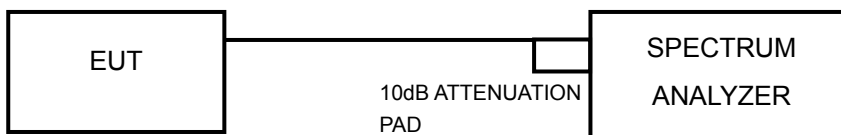

4.3.3 TEST INSTRUMENTS

Refer to section 4.1.3 to get information of above instrument.

4.3.4 TEST PROCEDURE

FOR AVERAGE POWER MEASUREMENT

A power sensor was used on the output port of the EUT. A power meter was used to read the response of the power sensor. Record the power level.

FOR 26dB OCCUPIED BANDWIDTH

- 1) Set RBW = approximately 1% of the emission bandwidth.
- 2) Set the VBW > RBW.
- 3) Detector = Peak.
- 4) Trace mode = max hold.
- 5) Measure the maximum width of the emission that is 26 dB down from the peak of the emission. Compare this with the RBW setting of the analyzer. Readjust RBW and repeat measurement as needed until the RBW/EBW ratio is approximately 1%.

4.3.5 DEVIATION FROM TEST STANDARD

No deviation.

4.3.6 EUT OPERATING CONDITIONS

The software provided by client to enable the EUT under transmission condition continuously at specific channel frequencies individually



4.3.7 TEST RESULTS

POWER OUTPUT: Channel Bandwidth (20MHz)

CHAN. FREQ. (MHz)	POWER OUTPUT (dBm)		TOTAL POWER (mW)	TOTAL POWER (dBm)	POWER LIMIT (dBm)	PASS / FAIL
	CHAIN 0	CHAIN 1				
5180	2.8	3.2	4.0	6.0	17	PASS
5200	2.6	3.4	4.0	6.0	17	PASS
5240	2.5	3.4	4.0	6.0	17	PASS

POWER OUTPUT: Channel Bandwidth (40MHz)

CHAN. FREQ. (MHz)	POWER OUTPUT (dBm)		TOTAL POWER (mW)	TOTAL POWER (dBm)	POWER LIMIT (dBm)	PASS / FAIL
	CHAIN 0	CHAIN 1				
5190	2.5	3.3	3.9	5.9	17	PASS
5230	2.4	3.3	3.9	5.9	17	PASS

26dB BANDWIDTH: (20MHz)

CHANNEL FREQUENCY (MHz)	26dBc BANDWIDTH (MHz)		PASS / FAIL
	CHAIN 0	CHAIN 1	
5180	19.72	19.66	PASS
5200	19.75	19.72	PASS
5240	19.72	19.69	PASS

26dB BANDWIDTH: (40MHz)

CHANNEL FREQUENCY (MHz)	26dBc BANDWIDTH (MHz)		PASS / FAIL
	CHAIN 0	CHAIN 1	
5190	40.81	40.94	PASS
5230	40.82	40.74	PASS

4.4 PEAK POWER EXCURSION MEASUREMENT

4.4.1 LIMITS OF PEAK POWER EXCURSION MEASUREMENT

Shall not exceed 13 dB

4.4.2 TEST SETUP

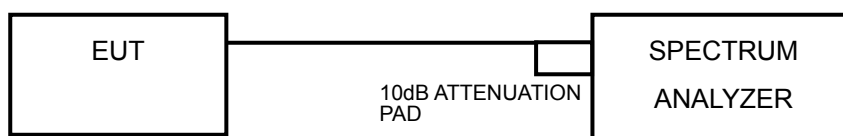

4.4.3 TEST INSTRUMENTS

Refer to section 4.1.3 to get information of above instrument.

4.4.4 TEST PROCEDURE

- 1) Set RBW = 1 MHz, VBW \leq 3 MHz, Detector = peak.
- 2) Trace mode = max-hold. Allow the sweeps to continue until the trace stabilizes.
- 3) Use the peak search function to find the peak of the spectrum.
- 4) Measure the PPSD.
- 5) Compute the ratio of the maximum of the peak-max-hold spectrum to the PPSD.

4.4.5 DEVIATION FROM TEST STANDARD

No deviation.

4.4.6 EUT OPERATING CONDITIONS

Same as 4.2.6

4.4.7 TEST RESULTS

Channel Bandwidth (20MHz)

CHAIN	CHANNEL FREQUENCY (MHz)	PEAK VALUE (dBm)	PPSD (dBm)	PEAK POWER EXCURSION (dB)	PEAK to AVERAGE EXCURSION LIMIT (dB)	PASS/ FAIL
0	5180	2.47	-10.30	12.77	13	PASS
	5200	2.41	-10.06	12.47	13	PASS
	5240	2.39	-10.00	12.39	13	PASS
1	5180	2.45	-9.19	11.64	13	PASS
	5200	2.79	-9.23	12.02	13	PASS
	5240	2.77	-9.28	12.05	13	PASS



A D T

FOR CHAIN 0: 5180MHz

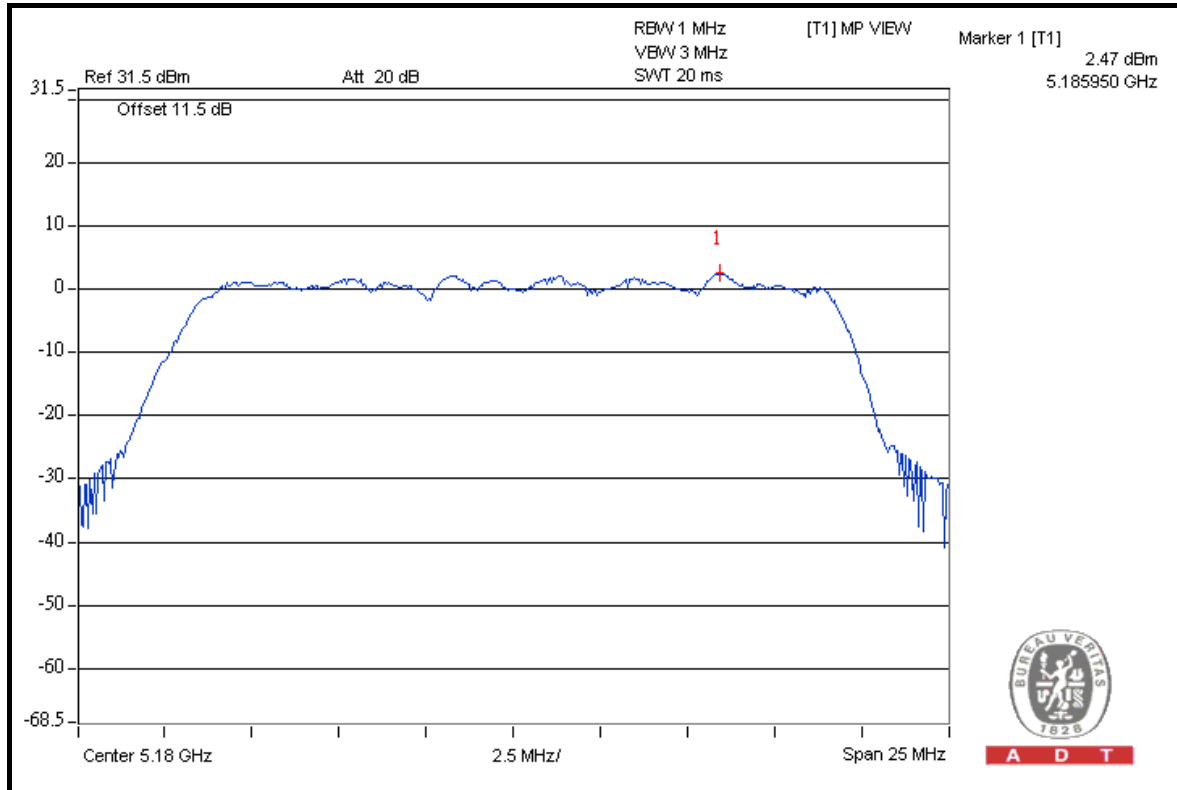

A D T

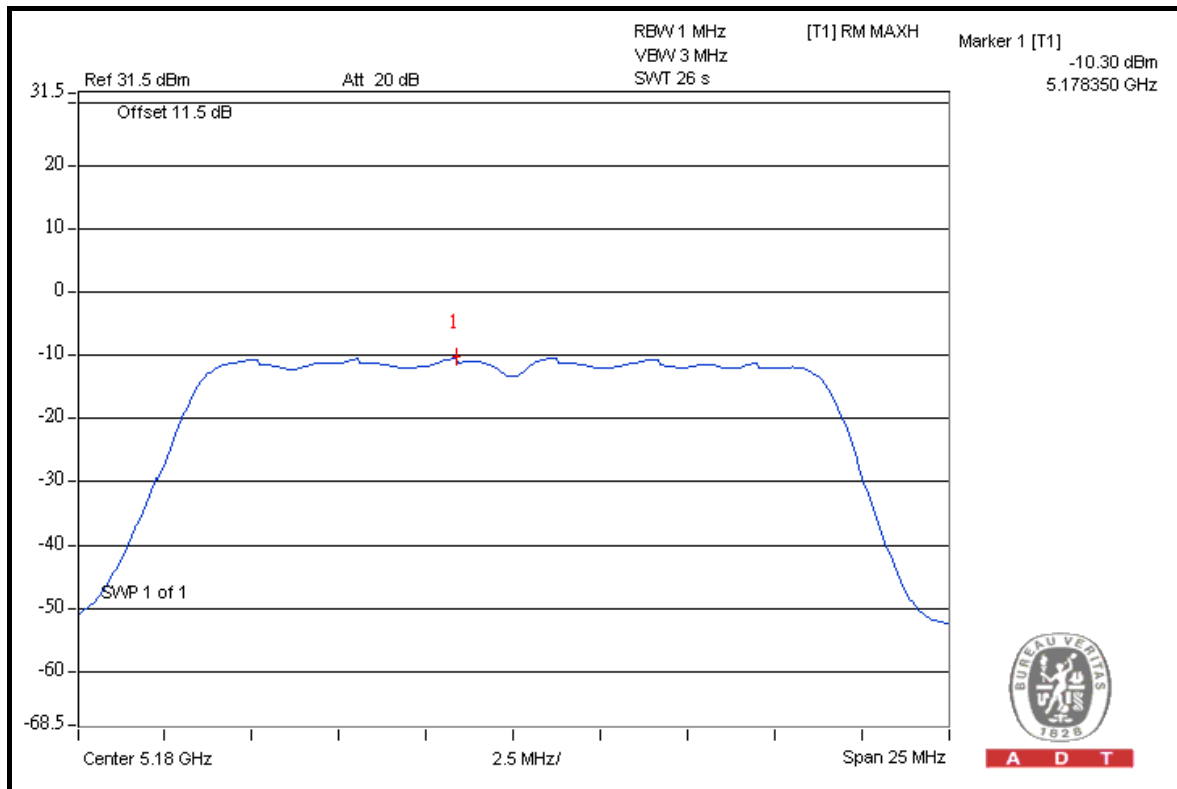

A D T



Channel Bandwidth (40MHz)

CHAIN	CHANNEL FREQUENCY (MHz)	PEAK VALUE (dBm)	PPSD (dBm)	PEAK POWER EXCURSION (dB)	PEAK to AVERAGE EXCURSION LIMIT (dB)	PASS/ FAIL
0	5190	1.07	-11.48	12.55	13	PASS
	5230	1.09	-11.66	12.75	13	PASS
1	5190	-0.10	-11.90	11.80	13	PASS
	5230	0.13	-11.91	12.04	13	PASS



A D T

FOR CHAIN 0: 5230MHz

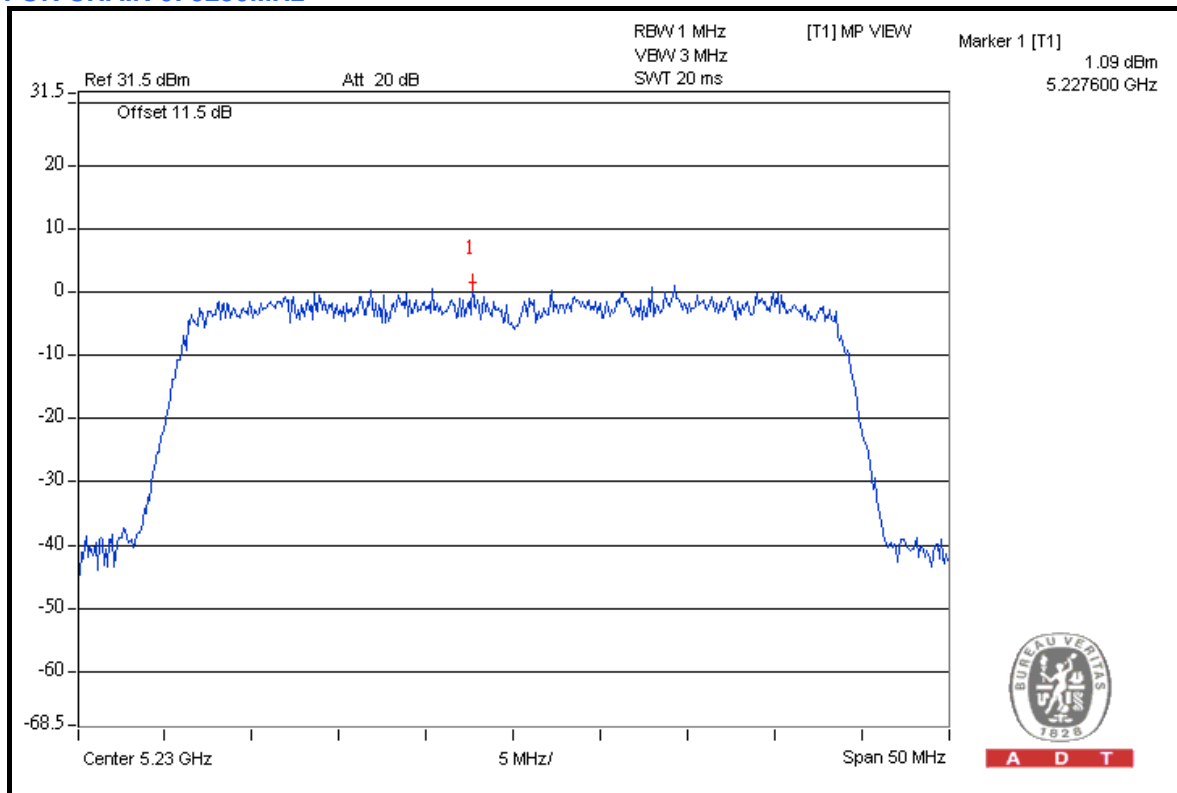

A D T

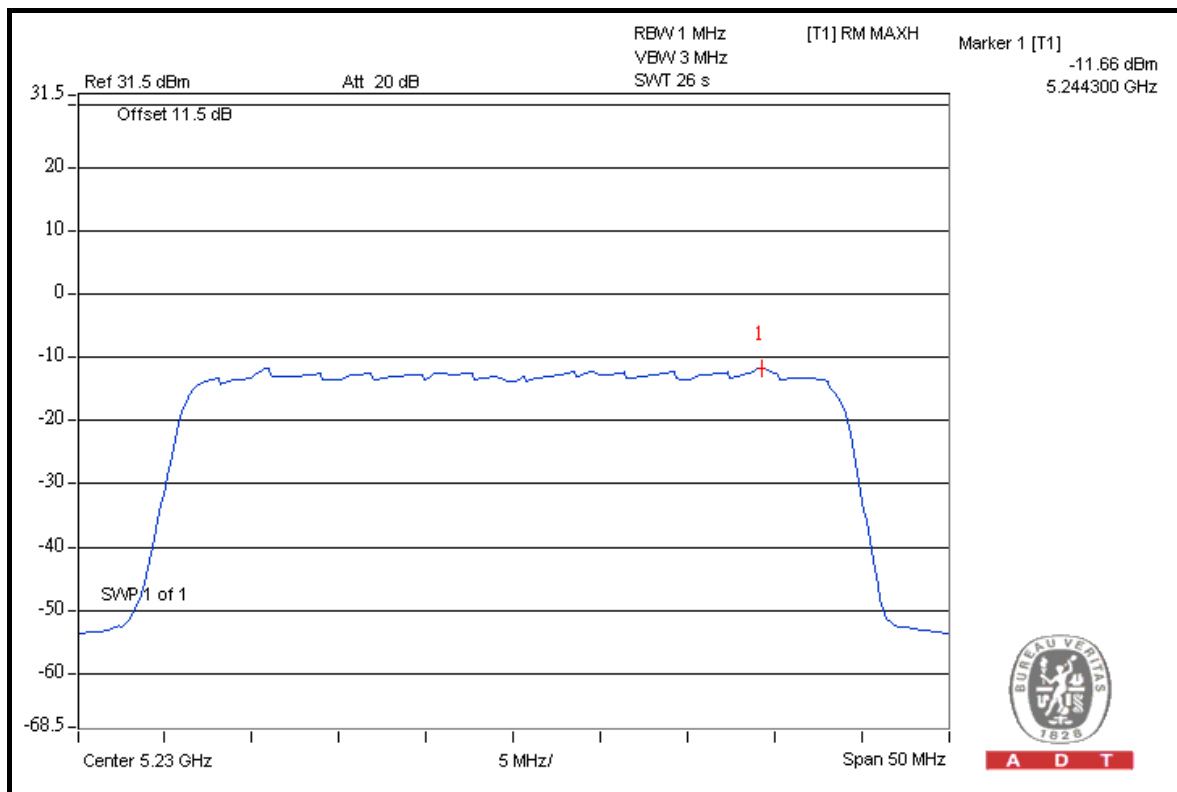

A D T

4.5 PEAK POWER SPECTRAL DENSITY MEASUREMENT

4.5.1 LIMITS OF PEAK POWER SPECTRAL DENSITY MEASUREMENT

FREQUENCY BAND	LIMIT(dBm)
5.15 ~ 5.25GHz	4
5.25 ~ 5.35GHz and 5.470 ~ 5.725GHz	11
5.725~5825GHz	17

4.5.2 TEST SETUP

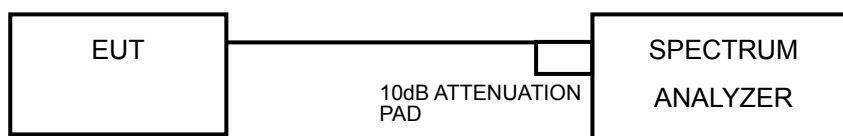

4.5.3 TEST INSTRUMENTS

Refer to section 4.1.3 to get information of above instrument.

4.5.4 TEST PROCEDURES

- 1) Set span to encompass the entire emission bandwidth (EBW) of the signal.
- 2) Set RBW = 1 MHz, Set VBW \geq 3 MHz, Detector = RMS
- 3) Sweep time = 26 second.
- 4) Perform a single sweep.
- 5) Record the max value

4.5.5 DEVIATION FROM TEST STANDARD

No deviation.

4.5.6 EUT OPERATING CONDITIONS

Same as 4.3.6.

4.5.7 TEST RESULTS

Channel Bandwidth (20MHz)

CHAIN	CHAN. FREQ. (MHz)	RF POWER LEVEL IN 1MHZ BW (dBm)		TOTAL POWER DENSITY (dBm)	MAX. LIMIT (dBm)	PASS / FAIL
		MEASURED	10 log (N=2) dB			
0	5180	-10.30	3.01	-7.29	4	PASS
	5200	-10.06	3.01	-7.05	4	PASS
	5240	-10.00	3.01	-6.99	4	PASS
1	5180	-9.19	3.01	-6.18	4	PASS
	5200	-9.23	3.01	-6.22	4	PASS
	5240	-9.28	3.01	-6.27	4	PASS

Channel Bandwidth (40MHz)

CHAIN	CHAN. FREQ. (MHz)	RF POWER LEVEL IN 1MHZ BW (dBm)		TOTAL POWER DENSITY (dBm)	MAX. LIMIT (dBm)	PASS / FAIL
		MEASURED	10 log (N=2) dB			
0	5190	-11.48	3.01	-8.47	4	PASS
	5230	-11.66	3.01	-8.65	4	PASS
1	5190	-11.90	3.01	-8.89	4	PASS
	5230	-11.91	3.01	-8.90	4	PASS

4.6 FREQUENCY STABILITY

4.6.1 LIMITS OF FREQUENCY STABILITY MEASUREMENT

The frequency of the carrier signal shall be maintained within band of operation

4.6.2 TEST SETUP

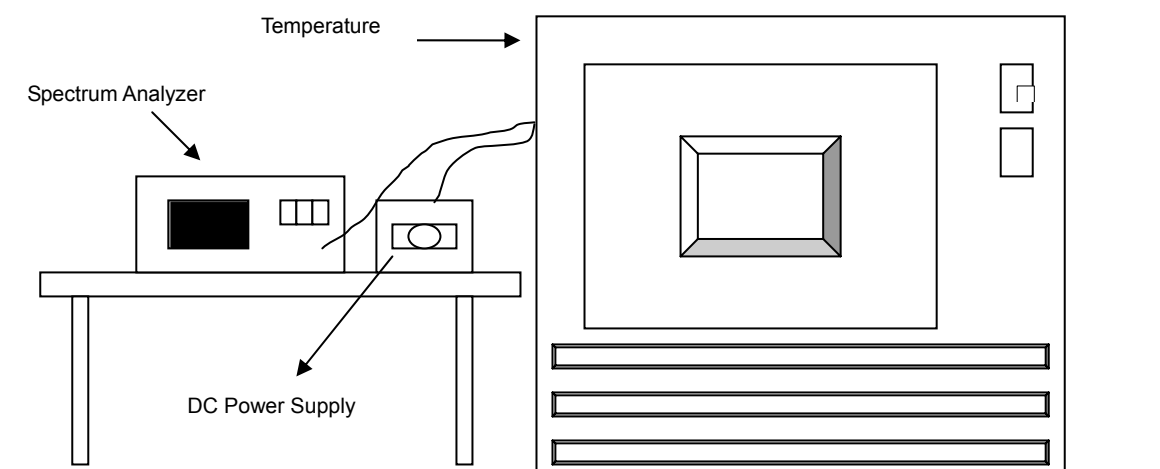

4.6.3 TEST INSTRUMENTS

Refer to section 4.1.3 to get information of above instrument.

4.6.4 TEST PROCEDURE

- a. The EUT was placed inside the environmental test chamber and powered by nominal DC voltage.
- b. Turn the EUT on and couple its output to a spectrum analyzer.
- c. Turn the EUT off and set the chamber to the highest temperature specified.
- d. Allow sufficient time (approximately 30 min) for the temperature of the chamber to stabilize, turn the EUT on and measure the operating frequency after 2, 5, and 10 minutes.
- e. Repeat step 2 and 3 with the temperature chamber set to the lowest temperature.
- f. The test chamber was allowed to stabilize at +20 degree C for a minimum of 30 minutes. The supply voltage was then adjusted on the EUT from 85% to 115% and the frequency record.

4.6.5 DEVIATION FROM TEST STANDARD

No deviation.

4.6.6 EUT OPERATING CONDITION

Set the EUT transmit at un-modulation mode to test frequency stability.



4.6.7 TEST RESULTS

FREQUENCY STABILITY VERSUS TEMP.									
OPERATING FREQUENCY: 5200MHz									
TEMP. (°C)	POWER SUPPLY (Vac)	0 MINUTE		2 MINUTE		5 MINUTE		10 MINUTE	
		Measured Frequency (MHz)	Frequency Drift (ppm)	Measured Frequency (MHz)	Frequency Drift (ppm)	Measured Frequency (MHz)	Frequency Drift (ppm)	Measured Frequency (MHz)	Frequency Drift (ppm)
50	110.0	5199.988198	-2.270	5199.988313	-2.247	5199.988543	-2.203	5199.988578	-2.197
40	110.0	5199.988846	-2.145	5199.988096	-2.289	5199.988169	-2.275	5199.988521	-2.207
30	110.0	5199.990378	-1.850	5199.989952	-1.932	5199.990325	-1.861	5199.990071	-1.909
20	110.0	5199.991570	-1.621	5199.991185	-1.695	5199.991445	-1.645	5199.991196	-1.693
10	110.0	5199.992973	-1.351	5199.992866	-1.372	5199.992771	-1.390	5199.992351	-1.471
0	110.0	5199.991778	-1.581	5199.992157	-1.508	5199.992271	-1.486	5199.991698	-1.597
-10	110.0	5199.989917	-1.939	5199.989835	-1.955	5199.989891	-1.944	5199.989998	-1.923
-20	110.0	5199.989146	-2.087	5199.988858	-2.143	5199.988627	-2.187	5199.989120	-2.092
-30	110.0	5199.988717	-2.170	5199.988919	-2.131	5199.988735	-2.166	5199.988978	-2.120

FREQUENCY STABILITY VERSUS VOLTAGE									
OPERATING FREQUENCY: 5200MHz									
TEMP. (°C)	POWER SUPPLY (Vac)	0 MINUTE		2 MINUTE		5 MINUTE		10 MINUTE	
		Measured Frequency (MHz)	Frequency Drift (ppm)	Measured Frequency (MHz)	Frequency Drift (ppm)	Measured Frequency (MHz)	Frequency Drift (ppm)	Measured Frequency (MHz)	Frequency Drift (ppm)
20	93.5	5199.990479	-1.831	5199.990250	-1.875	5199.990476	-1.832	5199.990565	-1.814
	110.0	5199.991460	-1.642	5199.991444	-1.645	5199.991734	-1.590	5199.991642	-1.607
	126.5	5199.992718	-1.400	5199.993334	-1.282	5199.993032	-1.340	5199.993283	-1.292

5. PHOTOGRAPHS OF THE TEST CONFIGURATION

Please refer to the attached file (Test Setup Photo).



6. INFORMATION ON THE TESTING LABORATORIES

We, Bureau Veritas Consumer Products Services (H.K.) Ltd., Taoyuan Branch, were founded in 1988 to provide our best service in EMC, Radio, Telecom and Safety consultation. Our laboratories are accredited and approved according to ISO/IEC 17025.

Copies of accreditation and authorization certificates of our laboratories obtained from approval agencies can be downloaded from our web site: www.adt.com.tw/index.5.phtml.

If you have any comments, please feel free to contact us at the following:

Linko EMC/RF Lab

Tel: 886-2-26052180

Fax: 886-2-26051924

Hsin Chu EMC/RF Lab

Tel: 886-3-5935343

Fax: 886-3-5935342

Hwa Ya EMC/RF/Safety/Telecom Lab

Tel: 886-3-3183232

Fax: 886-3-3270892

Email: service.adt@tw.bureauveritas.com

Web Site: www.adt.com.tw

The address and road map of all our labs can be found in our web site also.

7. APPENDIX A - MODIFICATIONS RECORDERS FOR ENGINEERING CHANGES TO THE EUT BY THE LAB

No any modifications are made to the EUT by the lab during the test.

---END---