

TEST REPORT

of

FCC Part 15 Subpart C

New Application; Class I PC; Class II PC

Product : Receiver
Brand: GIGABYTE
Model: GHOST Macro Station
Model Difference: N/A
FCC ID: JCK28713GHOSTRX
FCC Rule Part: §15.249
Applicant: GIGA-BYTE Technology Co., Ltd.
Address: No.6, Bao Chiang Road, Hsin-Tien Dist., New Taipei City 231, Taiwan

Test Performed by:

International Standards Laboratory

<Lung-Tan LAB>

*Site Registration No.

BSMI: SL2-IN-E-0013; MRA TW1036; TAF: 0997; IC: IC4067B-3;

*Address:

No. 120, Lane 180, San Ho Tsuen, Hsin Ho Rd.

Lung-Tan Hsiang, Tao Yuan County 325, Taiwan

*Tel : 886-3-407-1718; Fax: 886-3-407-1738

Report No.: **ISL-13LR107FC**

Issue Date : **2013/07/01**

Test results given in this report apply only to the specific sample(s) tested and are traceable to national or international standard through calibration of the equipment and evaluating measurement uncertainty herein.

This report MUST not be used to claim product endorsement by TAF, NVLAP or any agency of the Government.

This test report shall not be reproduced except in full, without the written approval of International Standards Laboratory.



VERIFICATION OF COMPLIANCE

Applicant: GIGA-BYTE Technology Co., Ltd.
Product Description: Receiver
Brand Name: GIGABYTE
FCC ID: JCK28713GHOSTRX
FCC Rule Part: §15.249
Model No.: GHOST Macro Station
Model Difference: N/A
Date of test: 2013/06/20 ~2013/06/28
Date of EUT Received: 2013/06/20

We hereby certify that:

All the tests in this report have been performed and recorded in accordance with the standards described above and performed by an independent electromagnetic compatibility consultant, International Standards Laboratory.

The test results contained in this report accurately represent the measurements of the characteristics and the energy generated by sample equipment under test at the time of the test. The sample equipment tested as described in this report is in compliance with the limits of above standards.

Test By: Dion Chen **Date:** 2013/07/01
Dion Chang / Engineer

Prepared By: Gigi yeh **Date:** 2013/07/01
Gigi Yeh / Specialist

Approved By: Vincent Su **Date:** 2013/07/01
Vincent Su / Technical Manager

Version

Version No.	Date	Description
00	2013/07/01	Initial creation of document

Table of Contents

1	GENERAL INFORMATION	5
1.1	PRODUCT DESCRIPTION	5
1.2	RELATED SUBMITTAL(S) / GRANT (S)	5
1.3	TEST METHODOLOGY.....	5
1.4	TEST FACILITY	5
1.5	SPECIAL ACCESSORIES.....	5
1.6	EQUIPMENT MODIFICATIONS	5
2	SYSTEM TEST CONFIGURATION	6
2.1	EUT CONFIGURATION.....	6
2.2	EUT EXERCISE	6
2.3	TEST PROCEDURE.....	6
2.4	MEASUREMENT EQUIPMENT USED:	7
2.5	LIMITATION	8
2.6	CONFIGURATION OF TESTED SYSTEM.....	10
3	SUMMARY OF TEST RESULTS	11
4	DESCRIPTION OF TEST MODES	11
5	CONDUCTED EMISSIONS TEST	12
5.1	MEASUREMENT PROCEDURE:	12
5.2	TEST SET-UP (BLOCK DIAGRAM OF CONFIGURATION)	12
5.3	MEASUREMENT EQUIPMENT USED:	12
5.4	MEASUREMENT RESULT:	13
6	RADIATED EMISSION TEST	15
6.1	MEASUREMENT PROCEDURE.....	15
6.2	TEST SET-UP (BLOCK DIAGRAM OF CONFIGURATION)	15
6.3	MEASUREMENT EQUIPMENT USED:	16
6.4	FIELD STRENGTH CALCULATION	16
6.5	MEASUREMENT RESULT	17
7	20 DB BAND WIDTH MEASUREMENT.....	27
7.1	MEASUREMENT PROCEDURE.....	27
7.2	TEST SET-UP (BLOCK DIAGRAM OF CONFIGURATION)	27
7.3	MEASUREMENT EQUIPMENT USED:	27
7.4	MEASUREMENT RESULTS:.....	27

1 GENERAL INFORMATION

1.1 Product Description

Product Name:	Receiver
Brand Name:	GIGABYTE
Model Name:	GHOST Macro Station
Model Difference:	N/A
Operation Frequency:	2402MHz, 2405MHz, 2408MHz, 2411MHz 2425MHz, 2435MHz, 2439MHz, 2443 MHz 2447MHz, 2450MHz, 2462MHz, 2465MHz 2468MHz, 2470MHz, 2471MHz, 2479 MHz
Channel number:	16 channels
Modulation Type:	GFSK
Power Supply:	5V DC form USB port
Antenna Designation:	Monopole Antenna

1.2 Related Submittal(s) / Grant (s)

This submittal(s) (test report) is intended for FCC ID: **JCK28713GHOSTRX** filing to comply with Section 15.249 of the FCC Part 15, Subpart C Rules.

1.3 Test Methodology

Both conducted and radiated testing were performed according to the procedures in ANSI C63.4 (2003). Radiated testing was performed at an antenna to EUT distance 3 meters.

1.4 Test Facility

The measurement facilities used to collect the 3m Radiated Emission and AC power line conducted data are located on the address of **International Standards Laboratory** <Lung-Tan LAB> No. 120, Lane 180, San Ho Tsuen, Hsin Ho Rd., Lung-Tan Hsiang, Tao Yuan County 325, Taiwan which are constructed and calibrated to meet the FCC requirements in documents ANSI C63.4: 2003. FCC Registration Number is: TW1036, Canada Registration Number: 4067B-3.

1.5 Special Accessories

Not available for this EUT intended for grant.

1.6 Equipment Modifications

Not available for this EUT intended for grant.

2 System Test Configuration

2.1 EUT Configuration

The EUT configuration for testing is installed on RF field strength measurement to meet the Commissions requirement and operating in a manner which intends to maximize its emission characteristics in a continuous normal application.

2.2 EUT Exercise

The Transmitter was operated in the engineering operating mode. the Tx frequency was fixed which was for the purpose of the measurements.

2.3 Test Procedure

2.3.1 Conducted Emissions

The EUT is a placed on as turn table which is 0.8 m above ground plane. According to the requirements in Section 7 and 13 of ANSI C63.4-2003. Conducted emissions from the EUT measured in the frequency range between 0.15 MHz and 30MHz using CISPR Quasi-Peak and Average detector mode.

2.3.2 Radiated Emissions

The EUT is a placed on as turn table which is 0.8 m above ground plane. The turn table shall rotate 360 degrees to determine the position of maximum emission level. EUT is set 3m away from the receiving antenna which varied from 1m to 4m to find out the highest emission. And also, each emission was to be maximized by changing the polarization of receiving antenna both horizontal and vertical. In order to find out the max. emission, the relative positions of this hand-held transmitter(EUT) was rotated through three orthogonal axes according to the requirements in Section 8 and 13 of ANSI C63.4-2003.

2.4 Measurement Equipment Used:

Conducted Emission Test Site					
EQUIPMENT TYPE	MFR	MODEL NUMBER	SERIAL NUMBER	LAST CAL.	CAL DUE.
Conduction 03 -1 Cable	WOKEN	CFD 300-NL	Conduction 0-1	06/28/2013	06/28/2014
EMI Receiver 12	ROHDE & SCHWARZ	ESCI	100804	07/16/2012	07/15/2013
LISN 07	FCC Inc.	FCC-LISN-50-100-4-02	07040	07/23/2012	07/22/2013
LISN 08	FCC	FCC-LISN50-25-2-01	07039	07/23/2012	07/22/2013

Chamber 14(966)					
EQUIPMENT TYPE	MFR	MODEL NUMBER	SERIAL NUMBER	LAST CAL.	CAL DUE.
Spectrum Analyzer 21(26.5GHz)	Agilent	N9010A	MY49060537	07/17/2012	07/16/2013
Spectrum Analyzer 20(6.5GHz)	Agilent	E4443A	MY48250315	05/26/2013	05/25/2014
Spectrum Analyzer 22(43GHz)	R&S	FSU43	100143	05/03/2013	05/02/2014
Loop Antenna9K-30M	A.H.SYSTEM	SAS-564	294	03/07/2013	03/06/2015
Bilog Antenna30-1G	Schaffner	CBL 6112B	2756	01/11/2013	01/10/2014
Horn antenna1-18G(06)	EMCO	3117	0006665	10/15/2012	10/14/2013
Horn antenna26-40G(05)	Com-power	AH-640	100A	01/09/2013	01/08/2015
Horn antenna18-26G(04)	Com-power	AH-826	081001	05/15/2013	05/14/2015
Preamplifier9-1000M	HP	8447D	NA	02/19/2013	02/18/2014
Preamplifier1-18G	MITEQ	AFS44-00101800-25-10P-44	1329256	07/23/2012	07/22/2013
Preamplifier1-26G	EM	EM01M26G	NA	02/26/2013	02/25/2014
Preamplifier26-40G	MITEQ	JS-26004000-27-5A	818471	05/08/2013	05/07/2015
Cable1-18G	HUBER SUHNER	Sucoflex 106	NA	09/07/2012	09/06/2013
Cable UP to 1G	HUBER SUHNER	RG 214/U	NA	10/08/2012	10/07/2013
SUCOFLEX 1GHz~40GHz cable	HUBER SUHNER	Sucoflex 102	27963/2&37421/2	09/21/2011	09/20/2013
2.4G Filter	Micro-Tronics	Brm50702	76	12/27/2012	12/26/2013

2.5 Limitation

(1) Conducted Emission

According to section 15.207(a) Conducted Emission Limits is as following.

Frequency (MHz)	Conducted Limit (dBuV)	
	Quasi-Peak	Average
0.15 – 0.5	66 - 56	56 - 46
0.5 – 5	56	46
5 - 30	60	50

(2) Radiated Emission 15.249(a)

The field strength of emissions from intentional radiators operated within these frequency bands shall comply with the following.

Frequency (MHz)	Field strength of Fundamental	Field strength of Harmonics	Distance (m)
902 - 928	50 mV/m (94dBuV/m)	500 uV/m (54dBuV/m)	3
2400 – 2483.5	50 mV/m (94dBuV/m)	500 uV/m (54dBuV/m)	3
5725 – 5875	50 mV/m (94dBuV/m)	500 uV/m (54dBuV/m)	3
24.0 – 24.25 GHz	250 mV/m (107.95dBuV/m)	2500 uV/m (67.95dBuV/m)	3

(3) Radiated Emission 15.249 (d)

Emission Radiated outside of the specified frequency bands, except for harmonics, shall be attenuated by at least 50dB below the level of the fundamental or to the general radiated emission limits in Section 15.209 as below, whichever is the lesser attenuation.

Frequency (MHz)	Field strength $\mu\text{V/m}$	Distance (m)	Field strength at 3m $\text{dB}\mu\text{V/m}$
1.705-30	30	30	69.54
30-88	100	3	40
88-216	150	3	43.5
216-960	200	3	46
Above 960	500	3	54

(4) Radiated Emission 15.249(e)

For frequencies above 1000MHz, the above field strength limits are based on average limits. The peak field strength of any emission shall not exceed the maximum permitted average limits specified above by more than 20dB under any condition of modulation.

- Remark:
1. Emission level in $\text{dB}\mu\text{V/m} = 20 \log (\mu\text{V/m})$
 2. Measurement was performed at an antenna to the closed point of EUT distance of meters.
 3. Only spurious frequency is permitted to locate within the Restricted Bands specified in provision of ξ 15.205
 4. Emission spurious frequency which appearing within the Restricted Bands specified in provision of ξ 15.205, then the general radiated emission limits in ξ 15.209 apply.

2.6 Configuration of Tested System

Fig. 2-1 Configuration of Radiated Emission Test

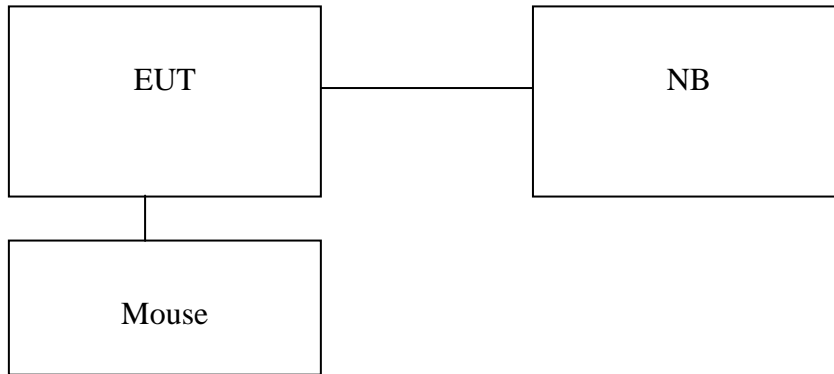

Table 2-1 Equipment Used in Tested System

Item	Equipment	Mfr/Brand	Model/ Type No.	Series No.	Data Cable	Power Cord
1	NB	Lenovo	X220i	N/A	Shield	No- Shielding

Note: All the above equipment/cables were placed in worse case positions to maximize emission signals during emission test.

Grounding: Grounding was in accordance with the manufacturer’s requirements and conditions for the intended use.

3 Summary of Test Results

FCC Rules	Description Of Test	Result
§15.207	Conducted Emission	Compliant
§15.249(a)(d)(e)	Radiated Emission	Compliant
§15.215 (c)	20dB band width Measurement	Compliant

4 Description of test modes

The EUT has been tested under operating condition with new battery.
The EUT is staying in continuous transmitting mode

Channel low (2402MHz)、 mid (2439MHz) and high (2479MHz) with highest data rate are chosen for full testing.

5 Conducted Emissions Test

5.1 Measurement Procedure:

1. The EUT was placed on a table which is 0.8m above ground plane.
2. Maximum procedure was performed on the six highest emissions to ensure EUT compliance.
3. Repeat above procedures until all frequency measured were complete.

5.2 Test SET-UP (Block Diagram of Configuration)

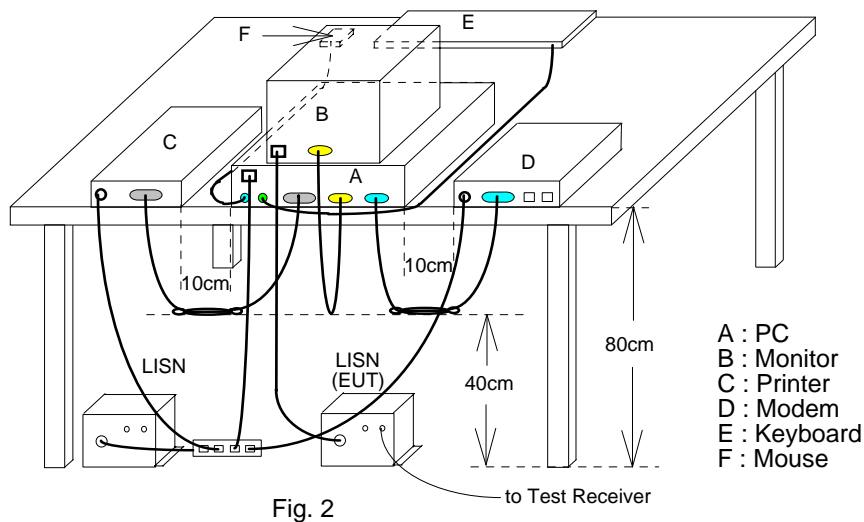

5.3 Measurement Equipment Used:

Refer to section 2.4 in this report

5.4 Measurement Result:

Date: 2013/6/24

Operator: Lake Cheng

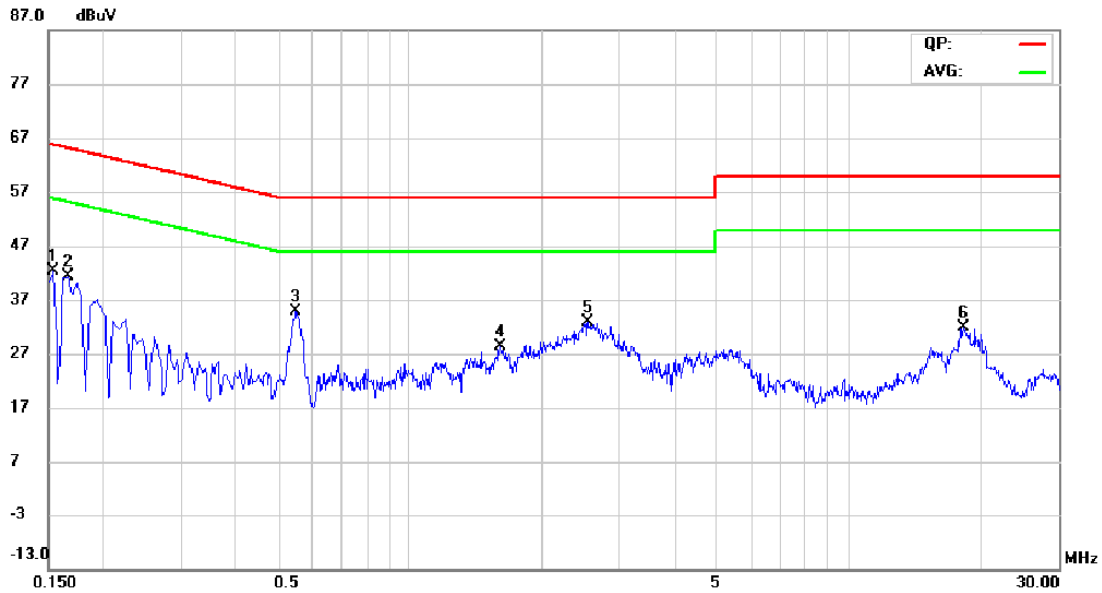

Site Conduction 04 Phase: **L1** Temperature: 26 °C
 Condition : CISPR22 Class B Conduction Humidity: 54 %

No.	Freq. MHz	Reading_Level (dBuV)			Correct Factor (dB)	Measurement (dBuV)			Limit (dBuV)		Margin (dB)		P/F	Comment
		Peak	QP	AVG		peak	QP	AVG	P/Q	AVG	P/Q	AVG		
1	0.1540	37.43	31.71	16.51	9.61	47.04	41.32	26.12	65.78	55.78	-24.46	-29.66		
2	0.1660	33.56	28.44	14.44	9.61	43.17	38.05	24.05	65.16	55.16	-27.11	-31.11		
3 *	0.5500	25.78	21.95	17.31	9.61	35.39	31.56	26.92	56.00	46.00	-24.44	-19.08		
4	1.6020	19.43	15.03	10.46	9.62	29.05	24.65	20.08	56.00	46.00	-31.35	-25.92		
5	2.5460	24.57	19.58	14.73	9.62	34.19	29.20	24.35	56.00	46.00	-26.80	-21.65		
6	18.2740	23.37	16.14	10.36	9.66	33.03	25.80	20.02	60.00	50.00	-34.20	-29.98		

Date: 2013/6/24

Operator: Lake Cheng

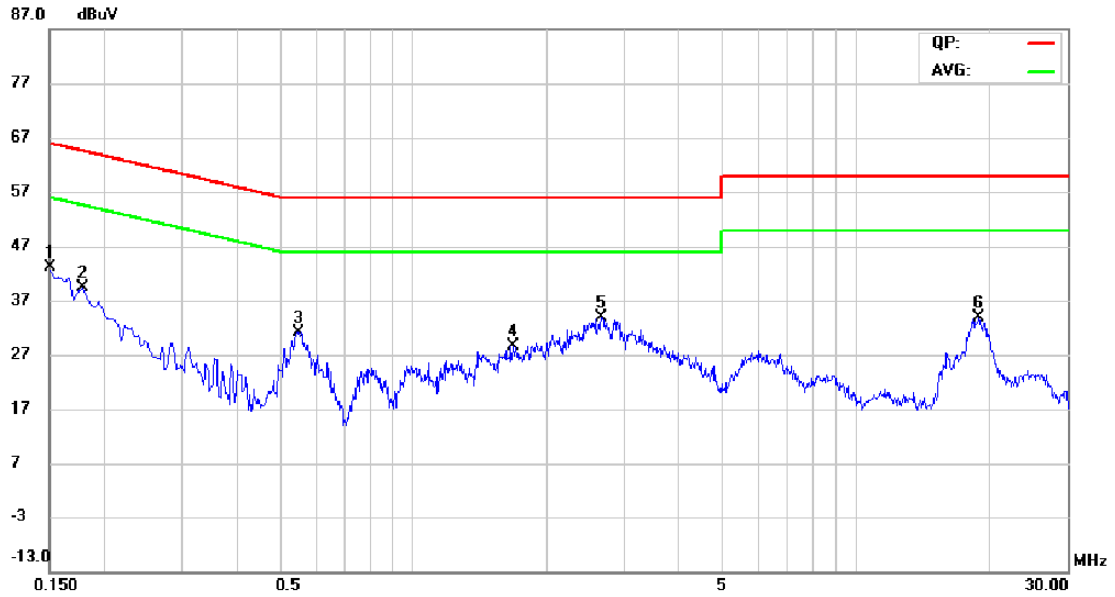

Site: Conduction 04 Phase: **N** Temperature: 26 °C
 Condition: CISPR22 Class B Conduction Humidity: 54 %

No.	Freq. MHz	Reading_Level (dBuV)			Correct Factor (dB)	Measurement (dBuV)			Limit (dBuV)		Margin (dB)		
		Peak	QP	AVG		peak	QP	AVG	P/Q	AVG	P/Q	AVG	P/F
1	0.1500	34.58	30.84	15.61	9.59	44.17	40.43	25.20	66.00	56.00	-25.57	-30.80	
2	0.1780	30.61	26.79	12.24	9.58	40.19	36.37	21.82	64.58	54.58	-28.21	-32.76	
3 *	0.5500	23.32	19.28	15.09	9.58	32.90	28.86	24.67	56.00	46.00	-27.14	-21.33	
4	1.6540	18.64	14.20	9.85	9.60	28.24	23.80	19.45	56.00	46.00	-32.20	-26.55	
5	2.6580	25.21	19.77	14.92	9.60	34.81	29.37	24.52	56.00	46.00	-26.63	-21.48	
6	18.9900	25.44	18.24	9.39	9.76	35.20	28.00	19.15	60.00	50.00	-32.00	-30.85	

6 Radiated Emission Test

6.1 Measurement Procedure

1. The EUT was placed on a turntable that is 0.8m above ground plane.
2. Maximum procedure was performed on the six highest emissions to ensure EUT compliance.
3. And also, each emission was to be maximized by changing the polarization of receiving antenna both horizontal and vertical.
4. Repeat above procedures until all frequency measured were complete.

6.2 Test SET-UP (Block Diagram of Configuration)

(A) Radiated Emission Test Set-Up, Frequency Below 1000MHz

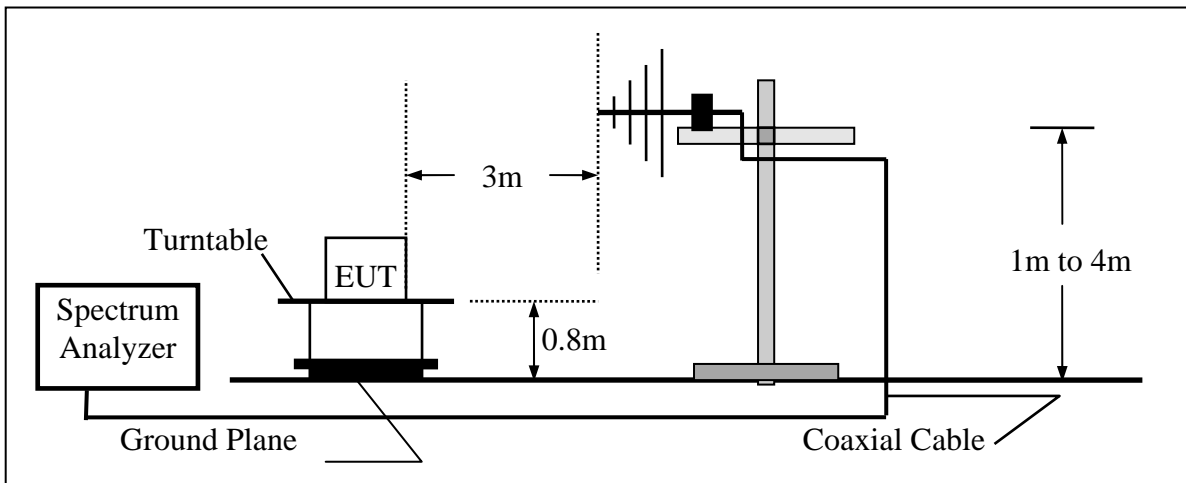

(B) Radiated Emission Test Set-UP Frequency Over 1 GHz

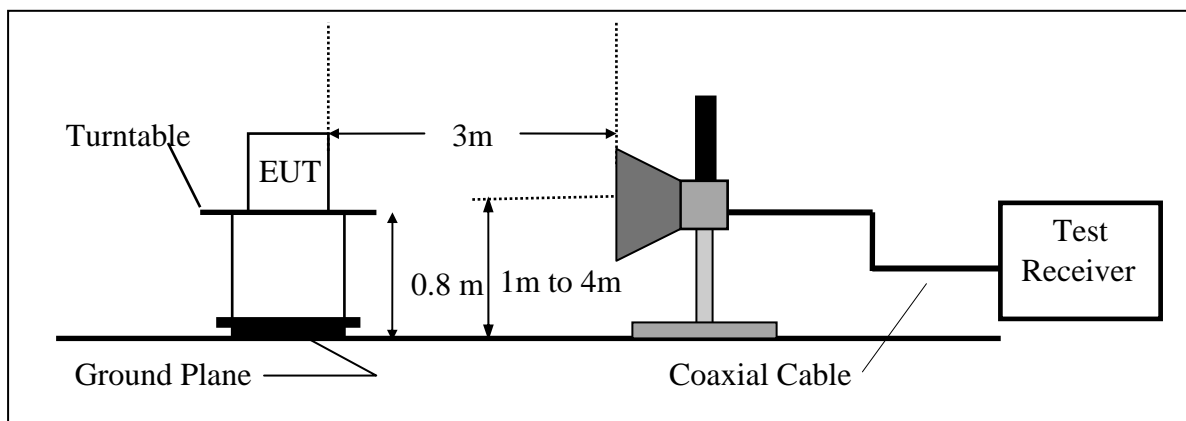

6.3 Measurement Equipment Used:

Refer to section 2.4 in this report

6.4 Field Strength Calculation

The field strength is calculated by adding the Antenna Factor and Cable Factor and subtracting the Amplifier Gain and Duty Cycle Correction Factor(if any) from the measured reading. The basic equation with a sample calculation is as follows:

$$FS = RA + AF + CL - AG$$

Where	FS = Field Strength	CL = Cable Attenuation Factor (Cable Loss)
	RA = Reading Amplitude	AG = Amplifier Gain
	AF = Antenna Factor	

6.5 Measurement Result

Fundamental Measurement Result

Operation Mode	: TX CH Low, Mid, High	Test Date	: 2013/06/24
Fundamental Frequency	: 2402, 2439, 2479MHz	Test By	: Dino
Temp	: 25	Hum.	: 60%

No	Freq MHz	Reading dBuV	Factor dB	Level dBuV/m	Limit dBuV/m	Over Limit dB	Remark	Pol V/H
1	2402.13	91.91	-6.98	84.93	114.00	-29.07	Peak	VERTICAL
1	2402.14	93.93	-6.98	86.95	114.00	-27.05	Peak	HORIZONTAL

No	Freq MHz	Reading dBuV	Factor dB	Level dBuV/m	Limit dBuV/m	Over Limit dB	Remark	Pol V/H
1	2439.13	92.76	-6.90	85.86	114.00	-28.14	Peak	VERTICAL
1	2439.12	94.87	-6.90	87.97	114.00	-26.03	Peak	HORIZONTAL

No	Freq MHz	Reading dBuV	Factor dB	Level dBuV/m	Limit dBuV/m	Over Limit dB	Remark	Pol V/H
1	2479.14	95.41	-6.82	88.59	114.00	-25.41	Peak	VERTICAL
1	2479.02	96.95	-6.82	90.13	114.00	-23.87	Peak	HORIZONTAL

Remark:

- 1 Measuring frequencies from the lowest internal frequency to the 10th of fundamental frequency
- 2 Field strength limits for frequency above 1000MHz are based on average limits. However, Peak mode field strength shall not exceed the average limits specified plus 20dB.
- 3 “F” denotes fundamental frequency; “H” denotes harmonics frequency. “S” denotes spurious frequency.
- 4 Measurement of data within this frequency range shown “ - ” in the table above means the reading of emissions are attenuated more than 20dB below the permissible limits or the field strength is too small to be measured.
- 5 Spectrum Peak mode IF bandwidth Setting : 1GHz- 26GHz, RBW= 1MHz, Sweep time= 200 ms., the VBW setting was 3 MHz.
- 6 Spectrum AV mode if bandwidth Setting : 1GHz- 26GHz, RBW= 1MHz, VBW= 10Hz, Sweep time= 200 ms.

Radiated Spurious Emission Measurement Result (below 1GHz)

Operation Mode	: TX CH Low	Test Date	: 2013/06/24
Fundamental Frequency	: 2402 MHz	Test By	: Dino
Temp	: 25	Hum.	: 60%

No	Freq MHz	Reading dBuV	Factor dB	Level dBuV/m	Limit dBuV/m	Over Limit dB	Remark	Pol V/H
1	38.73	39.47	-13.48	25.99	40.00	-14.01	Peak	VERTICAL
2	70.74	38.59	-16.04	22.55	40.00	-17.45	Peak	VERTICAL
3	114.39	39.79	-15.87	23.92	43.50	-19.58	Peak	VERTICAL
4	239.52	37.17	-14.20	22.97	46.00	-23.03	Peak	VERTICAL
5	462.62	39.56	-8.87	30.69	46.00	-15.31	Peak	VERTICAL
6	780.78	27.90	-2.82	25.08	46.00	-20.92	Peak	VERTICAL
1	46.49	31.37	-13.38	17.99	40.00	-22.01	Peak	HORIZONTAL
2	116.33	41.26	-15.64	25.62	43.50	-17.88	Peak	HORIZONTAL
3	267.65	34.27	-13.25	21.02	46.00	-24.98	Peak	HORIZONTAL
4	462.62	40.74	-8.87	31.87	46.00	-14.13	Peak	HORIZONTAL
5	687.66	30.91	-4.70	26.21	46.00	-19.79	Peak	HORIZONTAL
6	801.15	28.61	-2.66	25.95	46.00	-20.05	Peak	HORIZONTAL

Remark:

- 1 No further spurious emissions detected from the lowest internal frequency and 30MHz.
- 2 Measuring frequencies from the lowest internal frequency to the 1GHz.
- 3 Radiated emissions measured in frequency range from 30 MHz to 1000MHz were made with an instrument using Peak / QP detector mode.
- 4 Measurement result within this frequency range shown “ - ” in the table above means the reading of emissions are attenuated more than 20dB below the permissible limits or the field strength is too small to be measured.
- 5 The IF bandwidth of SPA between 30MHz to 1GHz was 100KHz, VBW=300KHz.

Radiated Spurious Emission Measurement Result (below 1GHz)

Operation Mode	: TX CH Mid	Test Date	: 2013/06/24
Fundamental Frequency	: 2439 MHz	Test By	: Dino
Temp	: 25	Hum.	: 60%

No	Freq MHz	Reading dBuV	Factor dB	Level dBuV/m	Limit dBuV/m	Over Limit dB	Remark	Pol V/H
1	40.67	39.79	-13.28	26.51	40.00	-13.49	Peak	VERTICAL
2	71.71	40.17	-16.31	23.86	40.00	-16.14	Peak	VERTICAL
3	115.36	39.29	-15.76	23.53	43.50	-19.97	Peak	VERTICAL
4	240.49	38.37	-14.15	24.22	46.00	-21.78	Peak	VERTICAL
5	480.08	39.75	-8.70	31.05	46.00	-14.95	Peak	VERTICAL
6	788.54	27.79	-2.75	25.04	46.00	-20.96	Peak	VERTICAL
1	51.34	32.15	-13.94	18.21	40.00	-21.79	Peak	HORIZONTAL
2	116.33	40.65	-15.64	25.01	43.50	-18.49	Peak	HORIZONTAL
3	159.98	34.80	-13.25	21.55	43.50	-21.95	Peak	HORIZONTAL
4	310.33	33.16	-11.87	21.29	46.00	-24.71	Peak	HORIZONTAL
5	461.65	41.02	-8.88	32.14	46.00	-13.86	Peak	HORIZONTAL
6	786.60	26.50	-2.78	23.72	46.00	-22.28	Peak	HORIZONTAL

Remark:

- 1 No further spurious emissions detected from the lowest internal frequency and 30MHz.
- 2 Measuring frequencies from the lowest internal frequency to the 1GHz.
- 3 Radiated emissions measured in frequency range from 30 MHz to 1000MHz were made with an instrument using Peak / QP detector mode.
- 4 Measurement result within this frequency range shown “ - ” in the table above means the reading of emissions are attenuated more than 20dB below the permissible limits or the field strength is too small to be measured.
- 5 The IF bandwidth of SPA between 30MHz to 1GHz was 100KHz, VBW=300KHz.

Radiated Spurious Emission Measurement Result (below 1GHz)

Operation Mode	: TX CH High	Test Date	: 2013/06/24
Fundamental Frequency	: 2479 MHz	Test By	: Dino
Temp	: 25	Hum.	: 60%

No	Freq MHz	Reading dBuV	Factor dB	Level dBuV/m	Limit dBuV/m	Over Limit dB	Remark	Pol V/H
1	38.73	39.30	-13.48	25.82	40.00	-14.18	Peak	VERTICAL
2	70.74	38.55	-16.04	22.51	40.00	-17.49	Peak	VERTICAL
3	115.36	39.32	-15.76	23.56	43.50	-19.94	Peak	VERTICAL
4	247.28	36.09	-13.98	22.11	46.00	-23.89	Peak	VERTICAL
5	468.44	37.57	-8.81	28.76	46.00	-17.24	Peak	VERTICAL
6	663.41	28.31	-5.08	23.23	46.00	-22.77	Peak	VERTICAL
1	46.49	30.96	-13.38	17.58	40.00	-22.42	Peak	HORIZONTAL
2	116.33	40.83	-15.64	25.19	43.50	-18.31	Peak	HORIZONTAL
3	163.86	35.13	-13.59	21.54	43.50	-21.96	Peak	HORIZONTAL
4	310.33	32.10	-11.87	20.23	46.00	-25.77	Peak	HORIZONTAL
5	359.80	33.73	-10.87	22.86	46.00	-23.14	Peak	HORIZONTAL
6	480.08	42.53	-8.70	33.83	46.00	-12.17	Peak	HORIZONTAL

Remark:

- 1 No further spurious emissions detected from the lowest internal frequency and 30MHz.
- 2 Measuring frequencies from the lowest internal frequency to the 1GHz.
- 3 Radiated emissions measured in frequency range from 30 MHz to 1000MHz were made with an instrument using Peak / QP detector mode.
- 4 Measurement result within this frequency range shown “ - ” in the table above means the reading of emissions are attenuated more than 20dB below the permissible limits or the field strength is too small to be measured.
- 5 The IF bandwidth of SPA between 30MHz to 1GHz was 100KHz, VBW=300KHz.

Radiated Spurious Emission Measurement Result (below 1GHz) (TX + Charger cable mode)

Operation Mode : TX CH High (worst) Test Date : 2013/06/24
 Fundamental Frequency : 2479 MHz Test By : Dino
 Temp : 25 Hum. : 60%

No	Freq MHz	Reading dBuV	Factor dB	Level dBuV/m	Limit dBuV/m	Over Limit dB	Remark	Pol V/H
1	108.57	47.08	-16.51	30.57	43.50	-12.93	Peak	VERTICAL
2	162.89	36.57	-13.50	23.07	43.50	-20.43	Peak	VERTICAL
3	333.61	37.04	-11.38	25.66	46.00	-20.34	Peak	VERTICAL
4	489.78	41.54	-8.60	32.94	46.00	-13.06	Peak	VERTICAL
5	599.39	39.74	-6.12	33.62	46.00	-12.38	Peak	VERTICAL
6	756.53	35.00	-3.00	32.00	46.00	-14.00	Peak	VERTICAL
1	107.60	47.32	-16.61	30.71	43.50	-12.79	Peak	HORIZONTAL
2	224.97	44.65	-15.18	29.47	46.00	-16.53	Peak	HORIZONTAL
3	271.53	38.02	-13.04	24.98	46.00	-21.02	Peak	HORIZONTAL
4	497.54	39.26	-8.54	30.72	46.00	-15.28	Peak	HORIZONTAL
5	699.30	35.55	-4.51	31.04	46.00	-14.96	Peak	HORIZONTAL
6	809.88	35.04	-2.56	32.48	46.00	-13.52	Peak	HORIZONTAL

Remark:

- 1 No further spurious emissions detected from the lowest internal frequency and 30MHz.
- 2 Measuring frequencies from the lowest internal frequency to the 1GHz.
- 3 Radiated emissions measured in frequency range from 30 MHz to 1000MHz were made with an instrument using Peak / QP detector mode.
- 4 Measurement result within this frequency range shown “ - ” in the table above means the reading of emissions are attenuated more than 20dB below the permissible limits or the field strength is too small to be measured.
- 5 The IF bandwidth of SPA between 30MHz to 1GHz was 100KHz, VBW=300KHz.

Radiated Spurious Emission Measurement Result (above 1GHz)

Operation Mode : TX CH Low Test Date : 2013/06/24
 Fundamental Frequency : 2402 MHz Test By : Dino
 Temp : 25 Hum. : 60%

No	Freq MHz	Reading dBuV	Factor dB	Level dBuV/m	Limit dBuV/m	Over Limit dB	Remark	Pol V/H
1	4804.00	50.77	1.25	52.02	74.00	-21.98	Peak	VERTICAL
2	7206.00	39.91	7.91	47.82	54.00	-6.18	Average	VERTICAL
3	7206.00	46.46	7.91	54.37	74.00	-19.63	Peak	VERTICAL
1	4804.00	51.12	1.25	52.37	74.00	-21.63	Peak	HORIZONTAL
2	7206.00	41.10	7.91	49.01	54.00	-4.99	Average	HORIZONTAL
3	7206.00	47.55	7.91	55.46	74.00	-18.54	Peak	HORIZONTAL

Remark:

- 1 Measuring frequencies from the lowest internal frequency to the 10th of fundamental frequency
- 2 Field strength limits for frequency above 1000MHz are based on average limits. However, Peak mode field strength shall not exceed the average limits specified plus 20dB.
- 3 “F” denotes fundamental frequency; “H” denotes harmonics frequency. “S” denotes spurious frequency.
- 4 Measurement of data within this frequency range shown “ - ” in the table above means the reading of emissions are attenuated more than 20dB below the permissible limits or the field strength is too small to be measured.
- 5 Spectrum Peak mode IF bandwidth Setting : 1GHz- 26GHz, RBW= 1MHz, Sweep time= 200 ms., the VBW setting was 3 MHz.
- 6 Spectrum AV mode if bandwidth Setting : 1GHz- 26GHz, RBW= 1MHz, VBW= 10Hz, Sweep time= 200 ms.

Radiated Spurious Emission Measurement Result (above 1GHz)

Operation Mode : TX CH Mid Test Date : 2013/06/24
 Fundamental Frequency : 2439 MHz Test By : Dino
 Temp : 25 Hum. : 60%

No	Freq MHz	Reading dBuV	Factor dB	Level dBuV/m	Limit dBuV/m	Over Limit dB	Remark	Pol V/H
1	4878.00	50.85	1.47	52.32	74.00	-21.68	Peak	VERTICAL
2	7317.00	41.98	8.02	50.00	54.00	-4.00	Average	VERTICAL
3	7317.00	47.87	8.02	55.89	74.00	-18.11	Peak	VERTICAL
1	4878.00	49.44	1.47	50.91	74.00	-23.09	Peak	HORIZONTAL
2	7317.00	41.60	8.02	49.62	54.00	-4.38	Average	HORIZONTAL
3	7317.00	48.37	8.02	56.39	74.00	-17.61	Peak	HORIZONTAL

Remark:

- 1 Measuring frequencies from the lowest internal frequency to the 10th of fundamental frequency
- 2 Field strength limits for frequency above 1000MHz are based on average limits. However, Peak mode field strength shall not exceed the average limits specified plus 20dB.
- 3 “F” denotes fundamental frequency; “H” denotes harmonics frequency. “S” denotes spurious frequency.
- 4 Measurement of data within this frequency range shown “ - ” in the table above means the reading of emissions are attenuated more than 20dB below the permissible limits or the field strength is too small to be measured.
- 5 Spectrum Peak mode IF bandwidth Setting : 1GHz- 26GHz, RBW= 1MHz, Sweep time= 200 ms., the VBW setting was 3 MHz.
- 6 Spectrum AV mode if bandwidth Setting : 1GHz- 26GHz, RBW= 1MHz, VBW= 10Hz, Sweep time= 200 ms.

Radiated Spurious Emission Measurement Result (above 1GHz)

Operation Mode	: TX CH High	Test Date	: 2013/06/24
Fundamental Frequency	: 2479 MHz	Test By	: Dino
Temp	: 25	Hum.	: 60%

No	Freq MHz	Reading dBuV	Factor dB	Level dBuV/m	Limit dBuV/m	Over Limit dB	Remark	Pol V/H
1	4958.00	49.24	1.72	50.96	74.00	-23.04	Peak	VERTICAL
2	7437.00	42.14	8.15	50.29	54.00	-3.71	Average	VERTICAL
3	7437.00	48.51	8.15	56.66	74.00	-17.34	Peak	VERTICAL
1	4958.00	48.42	1.72	50.14	74.00	-23.86	Peak	HORIZONTAL
2	7437.00	40.96	8.15	49.11	54.00	-4.89	Average	HORIZONTAL
3	7437.00	48.27	8.15	56.42	74.00	-17.58	Peak	HORIZONTAL

Remark:

- 1 Measuring frequencies from the lowest internal frequency to the 10th of fundamental frequency
- 2 Field strength limits for frequency above 1000MHz are based on average limits. However, Peak mode field strength shall not exceed the average limits specified plus 20dB.
- 3 “F” denotes fundamental frequency; “H” denotes harmonics frequency. “S” denotes spurious frequency.
- 4 Measurement of data within this frequency range shown “ - ” in the table above means the reading of emissions are attenuated more than 20dB below the permissible limits or the field strength is too small to be measured.
- 5 Spectrum Peak mode IF bandwidth Setting : 1GHz- 26GHz, RBW= 1MHz, Sweep time= 200 ms., the VBW setting was 3 MHz.
- 6 Spectrum AV mode if bandwidth Setting : 1GHz- 26GHz, RBW= 1MHz, VBW= 10Hz, Sweep time= 200 ms.

Radiated Spurious Emission Measurement Result (above 1GHz)

(TX + Charger cable mode)

Operation Mode	: TX CH High (Worst)	Test Date	: 2013/06/24
Fundamental Frequency	: 2479 MHz	Test By	: Dino
Temp	: 25	Hum.	: 60%

No	Freq MHz	Reading dBuV	Factor dB	Level dBuV/m	Limit dBuV/m	Over Limit dB	Remark	Pol V/H
1	4958.00	49.24	1.72	50.96	74.00	-23.04	Peak	VERTICAL
2	7437.00	42.14	8.15	50.29	54.00	-3.71	Average	VERTICAL
3	7437.00	48.51	8.15	56.66	74.00	-17.34	Peak	VERTICAL
1	4958.00	48.42	1.72	50.14	74.00	-23.86	Peak	HORIZONTAL
2	7437.00	40.96	8.15	49.11	54.00	-4.89	Average	HORIZONTAL
3	7437.00	48.27	8.15	56.42	74.00	-17.58	Peak	HORIZONTAL

Remark:

- 1 Measuring frequencies from the lowest internal frequency to the 10th of fundamental frequency
- 2 Field strength limits for frequency above 1000MHz are based on average limits. However, Peak mode field strength shall not exceed the average limits specified plus 20dB.
- 3 “F” denotes fundamental frequency; “H” denotes harmonics frequency. “S” denotes spurious frequency.
- 4 Measurement of data within this frequency range shown “ - ” in the table above means the reading of emissions are attenuated more than 20dB below the permissible limits or the field strength is too small to be measured.
- 5 Spectrum Peak mode IF bandwidth Setting : 1GHz- 26GHz, RBW= 1MHz, Sweep time= 200 ms., the VBW setting was 3 MHz.
- 6 Spectrum AV mode if bandwidth Setting : 1GHz- 26GHz, RBW= 1MHz, VBW= 10Hz, Sweep time= 200 ms.

Radiated Spurious Emission Measurement Result (Band Edge)

Operation Mode : Band Edge Test Date : 2013/06/24
 Temp./Hum. : 25 / : 60% Test By : Dino

CH Low

No	Freq MHz	Reading dBuV	Factor dB	Level dBuV/m	Limit dBuV/m	Over Limit dB	Remark	Pol V/H
1	2400.00	40.95	-6.99	33.96	54.00	-20.04	Average	VERTICAL
2	2400.00	68.40	-6.99	61.41	74.00	-12.59	Peak	VERTICAL
1	2400.00	41.90	-6.99	34.91	54.00	-19.09	Average	HORIZONTAL
2	2400.00	72.46	-6.99	65.47	74.00	-8.53	Peak	HORIZONTAL

CH High

No	Freq MHz	Reading dBuV	Factor dB	Level dBuV/m	Limit dBuV/m	Over Limit dB	Remark	Pol V/H
1	2483.50	38.91	-6.81	32.10	54.00	-21.90	Average	VERTICAL
2	2483.50	68.04	-6.81	61.23	74.00	-12.77	Peak	VERTICAL
3	2483.65	38.82	-6.81	32.01	54.00	-21.99	Average	VERTICAL
4	2483.65	68.62	-6.81	61.81	74.00	-12.19	Peak	VERTICAL
1	2483.50	38.73	-6.81	31.92	54.00	-22.08	Average	HORIZONTAL
2	2483.50	68.62	-6.81	61.81	74.00	-12.19	Peak	HORIZONTAL
3	2483.60	38.55	-6.81	31.74	54.00	-22.26	Average	HORIZONTAL
4	2483.60	69.50	-6.81	62.69	74.00	-11.31	Peak	HORIZONTAL

Remark:

- 1 Measuring frequencies from the lowest internal frequency to the 10th of fundamental frequency
- 2 Field strength limits for frequency above 1000MHz are based on average limits. However, Peak mode field strength shall not exceed the average limits specified plus 20dB.
- 3 “F” denotes fundamental frequency; “H” denotes harmonics frequency. “S” denotes spurious frequency.
- 4 Measurement of data within this frequency range shown “ - ” in the table above means the reading of emissions are attenuated more than 20dB below the permissible limits or the field strength is too small to be measured.
- 5 Spectrum Peak mode IF bandwidth Setting : 1GHz- 26GHz, RBW= 1MHz, Sweep time= 200 ms., the VBW setting was 3 MHz.
- 6 Spectrum AV mode if bandwidth Setting : 1GHz- 26GHz, RBW= 1MHz, VBW= 10Hz, Sweep time= 200 ms.

7 20 dB Band Width Measurement

7.1 Measurement Procedure

1. The EUT was placed on a turn table which is 0.8m above ground plane.
2. Set EUT normal operating mode.
3. Set SPA Center Frequency = fundamental frequency, RBW = 100kHz, VBW = 300kHz, Span = 10MHz.
4. Set SPA Max hold. Mark peak, -20dB.

7.2 Test SET-UP (Block Diagram of Configuration)

Same as 4.2 Radiated Emission Measurement.

7.3 Measurement Equipment Used:

Same as 4.2 Radiated Emission Measurement.

7.4 Measurement Results:

2402 Channel = 1.440MHz

2439 Channel = 1.107MHz

2479 Channel = 1.079MHz

Refer to attached data chart.

20dB Bandwidth Test Data CH-Low



20dB Bandwidth Test Data CH-Mid



20dB Bandwidth Test Data CH-High

