

# TEST REPORT

of

## FCC Part 15 Subpart C

New Application;  Class I PC;  Class II PC

**Product :** Wireless Receiver  
**Brand:** GIGABYTE  
**Model:** 28713AIREK17RX  
**Model Difference:** N/A  
**FCC ID:** JCK28713AIREK17RX  
**FCC Rule Part:** §15.249  
**Applicant:** GIGA-BYTE Technology Co., Ltd. .  
**Address:** No.6, Bao Chiang Road, Hsin-Tien Dist., New Taipei City 231, Taiwan

### Test Performed by:

#### International Standards Laboratory

<Lung-Tan LAB>

\*Site Registration No.

BSMI: SL2-IN-E-0013; MRA TW1036; TAF: 0997; IC: IC4067B-3;

\*Address:

No. 120, Lane 180, San Ho Tsuen, Hsin Ho Rd.

Lung-Tan Hsiang, Tao Yuan County 325, Taiwan

\*Tel : 886-3-407-1718; Fax: 886-3-407-1738

Report No.: **ISL-13LR279FC**

Issue Date : **2014/01/21**

Test results given in this report apply only to the specific sample(s) tested and are traceable to national or international standard through calibration of the equipment and evaluating measurement uncertainty herein.

This report MUST not be used to claim product endorsement by TAF, NVLAP or any agency of the Government.

This test report shall not be reproduced except in full, without the written approval of International Standards Laboratory.





### VERIFICATION OF COMPLIANCE

**Applicant:** GIGA-BYTE Technology Co., Ltd.  
**Product Description:** Wireless Receiver  
**Brand Name:** GIGABYTE  
**FCC ID:** JCK28713AIREK17RX  
**FCC Rule Part:** §15.249  
**Model No.:** 28713AIREK17RX  
**Model Difference:** N/A  
**Date of test:** 2013/12/30 ~2013/12/31  
**Date of EUT Received:** 2013/12/24

**We hereby certify that:**

All the tests in this report have been performed and recorded in accordance with the standards described above and performed by an independent electromagnetic compatibility consultant, International Standards Laboratory.

The test results contained in this report accurately represent the measurements of the characteristics and the energy generated by sample equipment under test at the time of the test. The sample equipment tested as described in this report is in compliance with the limits of above standards.

<b>Test By:</b>	 _____	<b>Date:</b>	2014/01/21 _____
	<i>Dion Chang / Engineer</i>		
<b>Prepared By:</b>	 _____	<b>Date:</b>	2014/01/21 _____
	<i>Eva Kao / Technical Supervisor</i>		
<b>Approved By:</b>	 _____	<b>Date:</b>	2014/01/21 _____
	<i>Vincent Su / Technical Manager</i>		

## Version

Version No.	Date	Description
00	2014/01/21	Initial creation of document

## Table of Contents

<b>1</b>	<b>GENERAL INFORMATION .....</b>	<b>5</b>
1.1	PRODUCT DESCRIPTION .....	5
1.2	RELATED SUBMITTAL(S) / GRANT (S) .....	6
1.3	TEST METHODOLOGY.....	6
1.4	TEST FACILITY .....	6
1.5	SPECIAL ACCESSORIES.....	6
1.6	EQUIPMENT MODIFICATIONS .....	6
<b>2</b>	<b>SYSTEM TEST CONFIGURATION .....</b>	<b>7</b>
2.1	EUT CONFIGURATION.....	7
2.2	EUT EXERCISE.....	7
2.3	TEST PROCEDURE.....	7
2.4	MEASUREMENT EQUIPMENT USED:.....	8
2.5	LIMITATION.....	9
2.6	CONFIGURATION OF TESTED SYSTEM.....	11
<b>3</b>	<b>SUMMARY OF TEST RESULTS .....</b>	<b>12</b>
<b>4</b>	<b>DESCRIPTION OF TEST MODES .....</b>	<b>12</b>
<b>5</b>	<b>CONDUCTED EMISSIONS TEST .....</b>	<b>13</b>
5.1	MEASUREMENT PROCEDURE: .....	13
5.2	TEST SET-UP (BLOCK DIAGRAM OF CONFIGURATION) .....	13
5.3	MEASUREMENT EQUIPMENT USED:.....	13
5.4	MEASUREMENT RESULT: .....	14
<b>6</b>	<b>RADIATED EMISSION TEST.....</b>	<b>16</b>
6.1	MEASUREMENT PROCEDURE.....	16
6.2	TEST SET-UP (BLOCK DIAGRAM OF CONFIGURATION) .....	16
6.3	MEASUREMENT EQUIPMENT USED:.....	17
6.4	FIELD STRENGTH CALCULATION.....	17
6.5	MEASUREMENT RESULT.....	18
<b>7</b>	<b>20 DB BAND WIDTH MEASUREMENT .....</b>	<b>28</b>
7.1	MEASUREMENT PROCEDURE.....	28
7.2	TEST SET-UP (BLOCK DIAGRAM OF CONFIGURATION) .....	28
7.3	MEASUREMENT EQUIPMENT USED:.....	28
7.4	MEASUREMENT RESULTS:.....	28
	<b>APPENDIX 1 PHOTOGRAPHS OF SETUP.....</b>	<b>31</b>
	<b>APPENDIX 2 PHOTOGRAPHS OF EUT .....</b>	<b>34</b>

# 1 GENERAL INFORMATION

## 1.1 Product Description

Product Name:	Wireless Receiver
Brand Name:	GIGABYTE
Model Name:	28713AIREK17RX
Model Difference:	N/A
Operation Frequency:	2408 MHz, 2410 MHz, 2412 MHz, 2414 MHz, 2416 MHz 2418 MHz, 2420 MHz, 2422 MHz, 2424 MHz, 2426 MHz 2428 MHz, 2430 MHz, 2432 MHz, 2434 MHz, 2436 MHz 2438 MHz, 2440 MHz, 2442 MHz, 2444 MHz, 2446 MHz 2448 MHz, 2450 MHz, 2452 MHz, 2454 MHz, 2456 MHz 2458 MHz, 2460 MHz, 2462 MHz, 2464 MHz, 2466 MHz 2468 MHz, 2470 MHz, 2472 MHz, 2474 MHz
Channel number:	34 channels
Modulation Type:	FSK
Power Supply:	5Vdc from USB port
Antenna Designation:	Printed Antenna

## 1.2 Related Submittal(s) / Grant (s)

This submittal(s) (test report) is intended for FCC ID: **JCK28713AIREK17RX** filing to comply with Section 15.249 of the FCC Part 15, Subpart C Rules.

## 1.3 Test Methodology

Both conducted and radiated testing was performed according to the procedures in ANSI C63.4 (2009). Radiated testing was performed at an antenna to EUT distance 3 meters.

## 1.4 Test Facility

The measurement facilities used to collect the 3m Radiated Emission and AC power line conducted data are located on the address of **International Standards Laboratory** <Lung-Tan LAB> No. 120, Lane 180, San Ho Tsuen, Hsin Ho Rd., Lung-Tan Hsiang, Tao Yuan County 325, Taiwan which are constructed and calibrated to meet the FCC requirements in documents ANSI C63.4: 2009. FCC Registration Number is: TW1036, Canada Registration Number: 4067B-3.

## 1.5 Special Accessories

Not available for this EUT intended for grant.

## 1.6 Equipment Modifications

Not available for this EUT intended for grant.

## **2 System Test Configuration**

### **2.1 EUT Configuration**

The EUT configuration for testing is installed on RF field strength measurement to meet the Commissions requirement and operating in a manner which intends to maximize its emission characteristics in a continuous normal application.

### **2.2 EUT Exercise**

The Transmitter was operated in the engineering operating mode. the Tx frequency was fixed which was for the purpose of the measurements.

### **2.3 Test Procedure**

#### **2.3.1 Conducted Emissions**

The EUT is a placed on as turn table which is 0.8 m above ground plane. According to the requirements in Section 7 and 13 of ANSI C63.4-2009. Conducted emissions from the EUT measured in the frequency range between 0.15 MHz and 30MHz using CISPR Quasi-Peak and Average detector mode.

#### **2.3.2 Radiated Emissions**

The EUT is a placed on as turn table which is 0.8 m above ground plane. The turn table shall rotate 360 degrees to determine the position of maximum emission level. EUT is set 3m away from the receiving antenna which varied from 1m to 4m to find out the highest emission. And also, each emission was to be maximized by changing the polarization of receiving antenna both horizontal and vertical. In order to find out the max. emission, the relative positions of this hand-held transmitter(EUT) was rotated through three orthogonal axes according to the requirements in Section 8 and 13 of ANSI C63.4-2009.

**2.4 Measurement Equipment Used:**

<b>Conducted Emission Test Site</b>					
<b>EQUIPMENT TYPE</b>	<b>MFR</b>	<b>MODEL NUMBER</b>	<b>SERIAL NUMBER</b>	<b>LAST CAL.</b>	<b>CAL DUE.</b>
Conduction 04-1 Cable	WOKEN	CFD 300-NL	Conduction 04 -1	09/24/2013	09/23/2014
EMI Receiver 16	Rohde & Schwarz	ESCI	101221	06/13/2013	06/12/2014
LISN 18	ROHDE & SCHWARZ	ENV216	101424	03/13/2013	03/12/2014
LISN 19	ROHDE & SCHWARZ	ENV216	101425	03/13/2013	03/12/2014

<b>Chamber 14(966)</b>					
<b>EQUIPMENT TYPE</b>	<b>MFR</b>	<b>MODEL NUMBER</b>	<b>SERIAL NUMBER</b>	<b>LAST CAL.</b>	<b>CAL DUE.</b>
Spectrum Analyzer 21(26.5GHz)	Agilent	N9010A	MY49060537	07/18/2013	07/17/2014
Spectrum Analyzer 20(6.5GHz)	Agilent	E4443A	MY48250315	05/26/2013	05/25/2014
Spectrum Analyzer 22(43GHz)	R&S	FSU43	100143	05/03/2013	05/02/2014
Loop Antenna9K-30M	A.H.SYSTEM	SAS-564	294	03/07/2013	03/06/2015
BILOG Antenna 08(30~1G)	Schaffner	CBL6112B	2756	01/15/2014	01/14/2015
Horn antenna1-18G(06)	EMCO	3117	0006665	11/04/2013	11/03/2014
Horn antenna26-40G(05)	Com-power	AH-640	100A	01/09/2013	01/08/2015
Horn antenna18-26G(04)	Com-power	AH-826	081001	05/15/2013	05/14/2015
Preamplifier9-1000M	HP	8447D	NA	02/19/2013	02/18/2014
Preamplifier1-18G	MITEQ	AFS44-001018 00-25-10P-44	1329256	07/18/2013	07/17/2014
Preamplifier1-26G	EM	EM01M26G	NA	02/26/2013	02/25/2014
Preamplifier26-40G	MITEQ	JS-26004000-2 7-5A	818471	05/08/2013	05/07/2015
Cable1-18G	HUBER SUHNER	Sucoflex 106	NA	02/06/2013	02/05/2014
Cable UP to 1G	HUBER SUHNER	RG 214/U	NA	10/08/2013	10/07/2014
SUCOFLEX 1GHz~40GHz cable	HUBER SUHNER	Sucoflex 102	27963/2&3742 1/2	10/03/2013	10/02/2015
2.4G Filter	Micro-Tronics	Brm50702	76	12/27/2013	12/26/2014



## 2.5 Limitation

### (1) Conducted Emission

According to section 15.207(a) Conducted Emission Limits is as following.

Frequency (MHz)	Conducted Limit (dBuV)	
	Quasi-Peak	Average
0.15 – 0.5	66 - 56	56 - 46
0.5 – 5	56	46
5 - 30	60	50

### (2) Radiated Emission 15.249(a)

The field strength of emissions from intentional radiators operated within these frequency bands shall comply with the following.

Frequency (MHz)	Field strength of Fundamental	Field strength of Harmonics	Distance (m)
902 - 928	50 mV/m (94dBuV/m)	500 uV/m (54dBuV/m)	3
2400 – 2483.5	50 mV/m (94dBuV/m)	500 uV/m (54dBuV/m)	3
5725 – 5875	50 mV/m (94dBuV/m)	500 uV/m (54dBuV/m)	3
24.0 – 24.25 GHz	250 mV/m (107.95dBuV/m)	2500 uV/m (67.95dBuV/m)	3

**(3) Radiated Emission 15.249 (d)**

Emission Radiated outside of the specified frequency bands, except for harmonics, shall be attenuated by at least 50dB below the level of the fundamental or to the general radiated emission limits in Section 15.209 as below, whichever is the lesser attenuation.

Frequency (MHz)	Field strength $\mu\text{V/m}$	Distance (m)	Field strength at 3m $\text{dB}\mu\text{V/m}$
1.705-30	30	30	69.54
30-88	100	3	40
88-216	150	3	43.5
216-960	200	3	46
Above 960	500	3	54

**(4) Radiated Emission 15.249(e)**

For frequencies above 1000MHz, the above field strength limits are based on average limits. The peak field strength of any emission shall not exceed the maximum permitted average limits specified above by more than 20dB under any condition of modulation.

- Remark:
1. Emission level in  $\text{dB}\mu\text{V/m} = 20 \log (\mu\text{V/m})$
  2. Measurement was performed at an antenna to the closed point of EUT distance of meters.
  3. Only spurious frequency is permitted to locate within the Restricted Bands specified in provision of  $\xi$  15.205
  4. Emission spurious frequency which appearing within the Restricted Bands specified in provision of  $\xi$  15.205, then the general radiated emission limits in  $\xi$  15.209 apply.

## 2.6 Configuration of Tested System

**Fig. 2-1 Configuration of Radiated Emission Test**

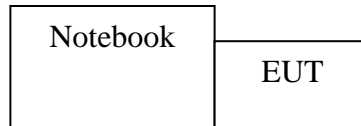

**Table 2-1 Equipment Used in Tested System**

Item	Equipment	Mfr/Brand	Model name	Series No	Data Cable	Power Cable
1	Notebook	LENOVO	X220i	N/A	N/A	Non-shield

**Note:** All the above equipment/cables were placed in worse case positions to maximize emission signals during emission test.

**Grounding:** Grounding was in accordance with the manufacturer's requirements and conditions for the intended use.

### 3 Summary of Test Results

FCC Rules	Description Of Test	Result
§15.207	Conducted Emission	Compliant
§15.249(a)(d)(e)	Radiated Emission	Compliant
§15.215 (c )	20dB band width Measurement	Compliant

### 4 Description of test modes

The EUT has been tested under operating condition with new battery.  
The EUT is staying in continuous transmitting mode

Channel low (2408MHz) 、 mid (2440MHz) and high (2474MHz) with highest data rate are chosen for full testing.

## 5 Conducted Emissions Test

### 5.1 Measurement Procedure:

1. The EUT was placed on a table which is 0.8m above ground plane.
2. Maximum procedure was performed on the six highest emissions to ensure EUT compliance.
3. Repeat above procedures until all frequency measured were complete.

### 5.2 Test SET-UP (Block Diagram of Configuration)

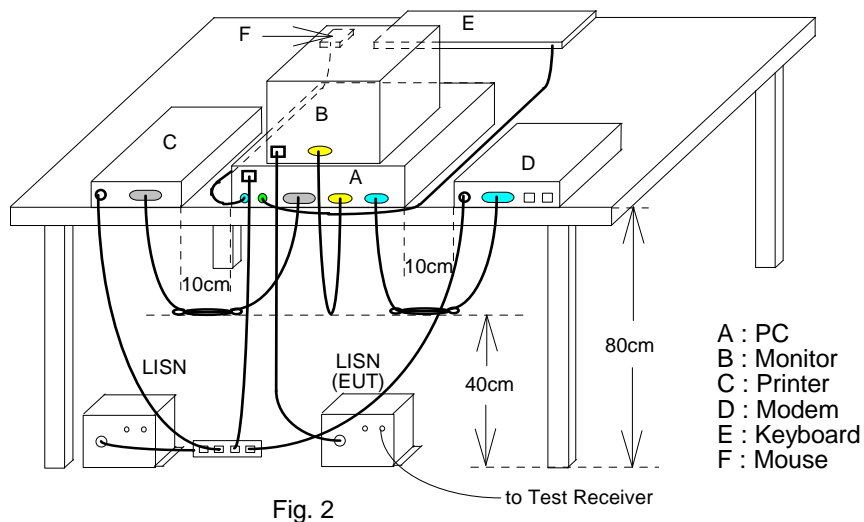

### 5.3 Measurement Equipment Used:

Refer to section 2.4 in this report

5.4 Measurement Result:



Address: No. 120, Lane 180, San Ho Tsuen, Hsin Ho Road, Lung-Tan Hsiang,  
Tao Yuan Conty, Taiwan R.O.C.  
Tel: 03-4071718

Date: 2013/12/30

Operator: Jason

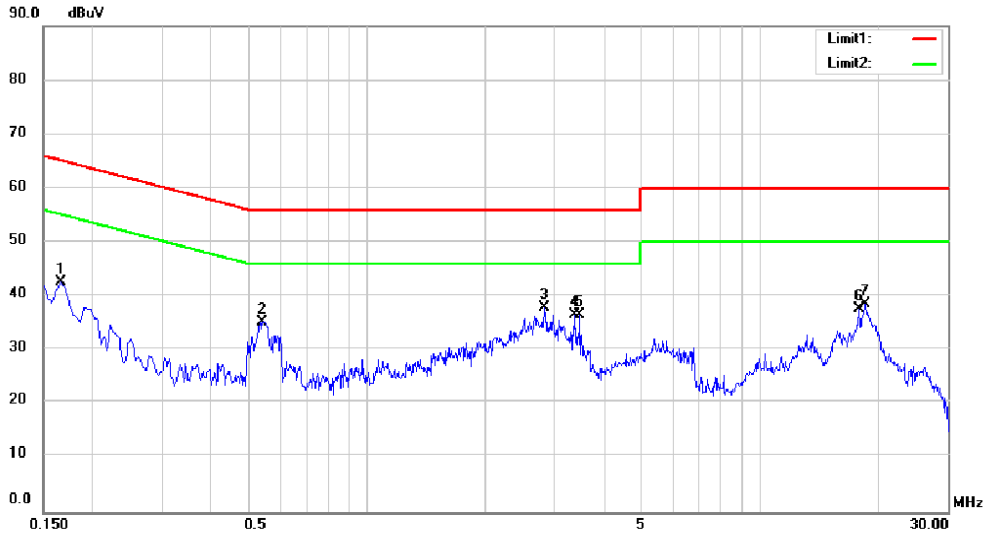

Site Conduction 04

Phase: **L1**

Temperature: 26 °C

Condition : Conduction

Humidity: 54 %

No.	Freq. MHz	Reading_Level (dBuV)			Correct Factor (dB)	Measurement (dBuV)			Limit (dBuV)		Margin (dB)			P/F	Comment
		Peak	QP	AVG		peak	QP	AVG	P/Q	AVG	P/Q	AVG			
1	0.1643	32.92	30.15	14.60	9.62	42.54	39.77	24.22	65.24	55.24	-25.47	-31.02			
2 *	0.5420	25.68	22.00	16.11	9.63	35.31	31.63	25.74	56.00	46.00	-24.37	-20.26			
3	2.8380	28.23	20.39	12.39	9.65	37.88	30.04	22.04	56.00	46.00	-25.96	-23.96			
4	3.3780	26.82	17.47	8.50	9.67	36.49	27.14	18.17	56.00	46.00	-28.86	-27.83			
5	3.4900	26.86	15.19	6.94	9.67	36.53	24.86	16.61	56.00	46.00	-31.14	-29.39			
6	17.8940	27.89	19.49	14.02	9.81	37.70	29.30	23.83	60.00	50.00	-30.70	-26.17			
7	18.6220	28.74	21.33	15.13	9.81	38.55	31.14	24.94	60.00	50.00	-28.86	-25.06			

\*:Maximum data x:Over limit !:over margin



Address: No. 120, Lane 180, San Ho Tsuen, Hsin Ho Road, Lung-Tan Hsiang,  
Tao Yuan Conty, Taiwan R.O.C.  
Tel: 03-4071718

Date: 2013/12/30

Operator: Jason

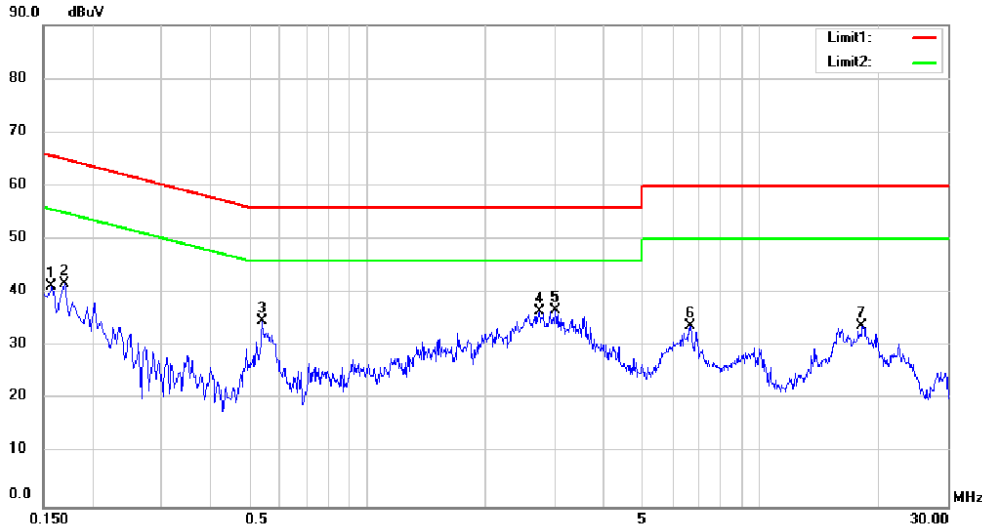

Site Conduction 04

Phase: *N*

Temperature: 26 °C

Condition : Conduction

Humidity: 54 %

No.	Freq. MHz	Reading_Level (dBuV)			Correct Factor (dB)	Measurement (dBuV)			Limit (dBuV)		Margin (dB)			P/F	Comment
		Peak	QP	AVG		peak	QP	AVG	P/Q	AVG	P/Q	AVG			
1	0.1580	31.77	28.12	12.15	9.60	41.37	37.72	21.75	65.57	55.57	-27.85	-33.82			
2	0.1700	32.24	29.55	13.13	9.60	41.84	39.15	22.73	64.96	54.96	-25.81	-32.23			
3	0.5420	25.23	19.71	15.03	9.60	34.83	29.31	24.63	56.00	46.00	-26.69	-21.37			
4 *	2.7580	26.92	21.81	16.30	9.63	36.55	31.44	25.93	56.00	46.00	-24.56	-20.07			
5	3.0180	27.04	21.32	14.57	9.65	36.69	30.97	24.22	56.00	46.00	-25.03	-21.78			
6	6.6420	24.20	16.19	9.58	9.69	33.89	25.88	19.27	60.00	50.00	-34.12	-30.73			
7	18.2260	24.04	16.25	9.39	9.90	33.94	26.15	19.29	60.00	50.00	-33.85	-30.71			

\*:Maximum data    x:Over limit    !:over margin

## 6 Radiated Emission Test

### 6.1 Measurement Procedure

1. The EUT was placed on a turntable that is 0.8m above ground plane.
2. Maximum procedure was performed on the six highest emissions to ensure EUT compliance.
3. And also, each emission was to be maximized by changing the polarization of receiving antenna both horizontal and vertical.
4. Repeat above procedures until all frequency measured were complete.

### 6.2 Test SET-UP (Block Diagram of Configuration)

(A) Radiated Emission Test Set-Up, Frequency Below 1000MHz

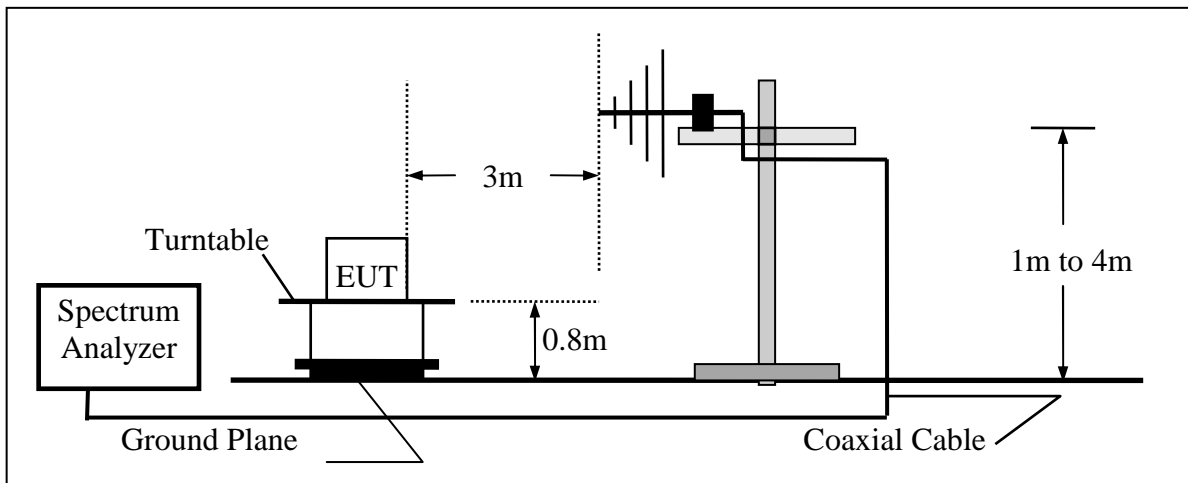

(B) Radiated Emission Test Set-UP Frequency Over 1 GHz

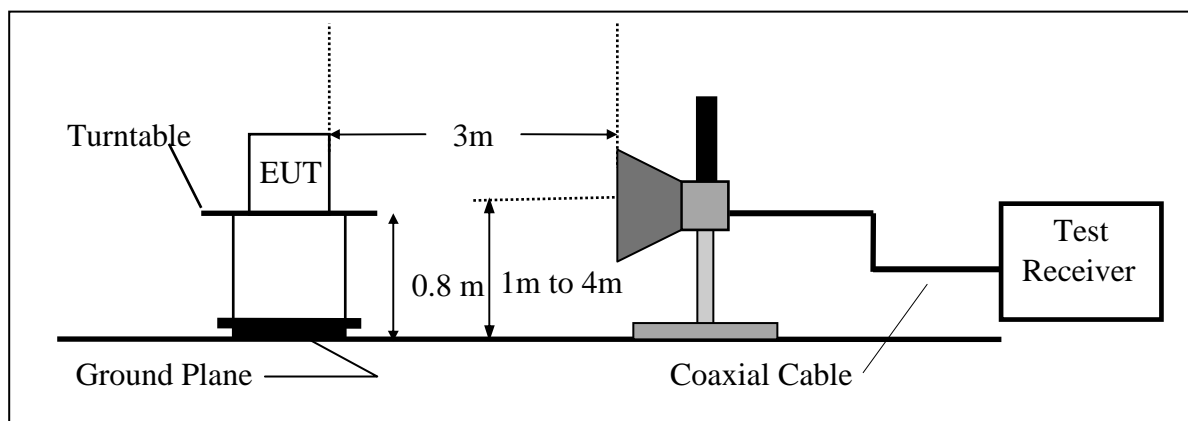



### 6.3 Measurement Equipment Used:

Refer to section 2.4 in this report

### 6.4 Field Strength Calculation

The field strength is calculated by adding the Antenna Factor and Cable Factor and subtracting the Amplifier Gain and Duty Cycle Correction Factor(if any) from the measured reading. The basic equation with a sample calculation is as follows:

$$FS = RA + AF + CL - AG$$

Where	FS = Field Strength	CL = Cable Attenuation Factor (Cable Loss)
	RA = Reading Amplitude	AG = Amplifier Gain
	AF = Antenna Factor	

## 6.5 Measurement Result

### Fundamental Measurement Result

Operation Mode	: TX CH Low, Mid, High	Test Date	: 2013/12/31
Fundamental Frequency	: 2408, 2440, 2474MHz	Test By	: Dino
Temp	: 25 °C	Hum.	: 60%

No	Freq MHz	Reading dBuV	Factor dB	Level dBuV/m	Limit dBuV/m	Over Limit dB	Remark	Pol V/H
1	2407.47	86.55	-7.05	79.50	94.00	-14.50	Average	VERTICAL
2	2407.47	102.61	-7.05	95.56	114.00	-18.44	Peak	VERTICAL
1	2407.49	87.86	-7.05	80.81	94.00	-13.19	Average	HORIZONTAL
2	2407.49	103.42	-7.05	96.37	114.00	-17.63	Peak	HORIZONTAL

No	Freq MHz	Reading dBuV	Factor dB	Level dBuV/m	Limit dBuV/m	Over Limit dB	Remark	Pol V/H
1	2439.44	85.47	-6.99	78.48	94.00	-15.52	Average	VERTICAL
2	2439.44	100.69	-6.99	93.70	114.00	-20.30	Peak	VERTICAL
1	2439.46	86.73	-6.99	79.74	94.00	-14.26	Average	HORIZONTAL
2	2439.46	101.61	-6.99	94.62	114.00	-19.38	Peak	HORIZONTAL

No	Freq MHz	Reading dBuV	Factor dB	Level dBuV/m	Limit dBuV/m	Over Limit dB	Remark	Pol V/H
1	2473.47	85.22	-6.92	78.30	94.00	-15.70	Average	VERTICAL
2	2473.47	100.54	-6.92	93.62	114.00	-20.38	Peak	VERTICAL
1	2473.47	86.74	-6.92	79.82	94.00	-14.18	Average	HORIZONTAL
2	2473.47	100.97	-6.92	94.05	114.00	-19.95	Peak	HORIZONTAL

Remark:

- 1 Measuring frequencies from the lowest internal frequency to the 10th of fundamental frequency
- 2 Field strength limits for frequency above 1000MHz are based on average limits. However, Peak mode field strength shall not exceed the average limits specified plus 20dB.
- 3 “F” denotes fundamental frequency; “H” denotes harmonics frequency. “S” denotes spurious frequency.

- 4 Measurement of data within this frequency range shown “ - ” in the table above means the reading of emissions are attenuated more than 20dB below the permissible limits or the field strength is too small to be measured.
- 5 Spectrum Peak mode IF bandwidth Setting : 1GHz- 26GHz, RBW= 1MHz, Sweep time= 200 ms., the VBW setting was 3 MHz.
- 6 Spectrum AV mode if bandwidth Setting : 1GHz- 26GHz, RBW= 1MHz, VBW= 10Hz, Sweep time= 200 ms.

**Radiated Spurious Emission Measurement Result (below 1GHz)**

Operation Mode	: TX CH Low	Test Date	: 2013/12/31
Fundamental Frequency	: 2408 MHz	Test By	: Dino
Temp	: 25 °C	Hum.	: 60%

No	Freq MHz	Reading dBuV	Factor dB	Level dBuV/m	Limit dBuV/m	Over Limit dB	Remark	Pol V/H
1	51.34	40.49	-12.19	28.30	40.00	-11.70	Peak	VERTICAL
2	151.25	41.78	-12.04	29.74	43.50	-13.76	Peak	VERTICAL
3	295.78	44.45	-11.21	33.24	46.00	-12.76	Peak	VERTICAL
4	334.58	41.27	-10.46	30.81	46.00	-15.19	Peak	VERTICAL
5	742.95	35.98	-3.08	32.90	46.00	-13.10	Peak	VERTICAL
6	816.67	35.81	-2.22	33.59	46.00	-12.41	Peak	VERTICAL
1	296.75	42.77	-11.17	31.60	46.00	-14.40	Peak	HORIZONTAL
2	334.58	39.65	-10.46	29.19	46.00	-16.81	Peak	HORIZONTAL
3	665.35	35.28	-4.74	30.54	46.00	-15.46	Peak	HORIZONTAL
4	742.95	35.98	-3.08	32.90	46.00	-13.10	Peak	HORIZONTAL
5	816.67	35.81	-2.22	33.59	46.00	-12.41	Peak	HORIZONTAL
6	891.36	31.68	-0.94	30.74	46.00	-15.26	Peak	HORIZONTAL

Remark:

- 1 No further spurious emissions detected from the lowest internal frequency and 30MHz.
- 2 Measuring frequencies from the lowest internal frequency to the 1GHz.
- 3 Radiated emissions measured in frequency range from 30 MHz to 1000MHz were made with an instrument using Peak / QP detector mode.
- 4 Measurement result within this frequency range shown “ - ” in the table above means the reading of emissions are attenuated more than 20dB below the permissible limits or the field strength is too small to be measured.
- 5 The IF bandwidth of SPA between 30MHz to 1GHz was 100KHz, VBW=300KHz.

### Radiated Spurious Emission Measurement Result (below 1GHz)

Operation Mode	: TX CH Mid	Test Date	: 2013/12/31
Fundamental Frequency	: 2440 MHz	Test By	: Dino
Temp	: 25 °C	Hum.	: 60%

No	Freq MHz	Reading dBuV	Factor dB	Level dBuV/m	Limit dBuV/m	Over Limit dB	Remark	Pol V/H
1	51.34	40.36	-12.19	28.17	40.00	-11.83	Peak	VERTICAL
2	150.28	41.54	-12.04	29.50	43.50	-14.00	Peak	VERTICAL
3	295.78	39.57	-11.21	28.36	46.00	-17.64	Peak	VERTICAL
4	334.58	40.09	-10.46	29.63	46.00	-16.37	Peak	VERTICAL
5	591.63	37.03	-5.85	31.18	46.00	-14.82	Peak	VERTICAL
6	850.62	33.99	-1.71	32.28	46.00	-13.72	Peak	VERTICAL
1	296.75	44.53	-11.17	33.36	46.00	-12.64	Peak	HORIZONTAL
2	333.61	42.26	-10.48	31.78	46.00	-14.22	Peak	HORIZONTAL
3	668.26	34.98	-4.69	30.29	46.00	-15.71	Peak	HORIZONTAL
4	740.04	35.90	-3.15	32.75	46.00	-13.25	Peak	HORIZONTAL
5	776.90	31.47	-2.67	28.80	46.00	-17.20	Peak	HORIZONTAL
6	813.76	34.95	-2.27	32.68	46.00	-13.32	Peak	HORIZONTAL

Remark:

- 1 No further spurious emissions detected from the lowest internal frequency and 30MHz.
- 2 Measuring frequencies from the lowest internal frequency to the 1GHz.
- 3 Radiated emissions measured in frequency range from 30 MHz to 1000MHz were made with an instrument using Peak / QP detector mode.
- 4 Measurement result within this frequency range shown “ - ” in the table above means the reading of emissions are attenuated more than 20dB below the permissible limits or the field strength is too small to be measured.
- 5 The IF bandwidth of SPA between 30MHz to 1GHz was 100KHz, VBW=300KHz.

**Radiated Spurious Emission Measurement Result (below 1GHz)**

Operation Mode : TX CH High                      Test Date : 2013/12/31  
 Fundamental Frequency :2474 MHz              Test By : Dino  
 Temp : 25 °C    Hum. : 60%

No	Freq MHz	Reading dBuV	Factor dB	Level dBuV/m	Limit dBuV/m	Over Limit dB	Remark	Pol V/H
1	52.31	40.34	-12.24	28.10	40.00	-11.90	Peak	VERTICAL
2	152.22	41.30	-12.04	29.26	43.50	-14.24	Peak	VERTICAL
3	296.75	38.53	-11.17	27.36	46.00	-18.64	Peak	VERTICAL
4	333.61	38.82	-10.48	28.34	46.00	-17.66	Peak	VERTICAL
5	591.63	38.50	-5.85	32.65	46.00	-13.35	Peak	VERTICAL
6	816.67	30.68	-2.22	28.46	46.00	-17.54	Peak	VERTICAL
1	296.75	43.11	-11.17	31.94	46.00	-14.06	Peak	HORIZONTAL
2	332.64	39.14	-10.50	28.64	46.00	-17.36	Peak	HORIZONTAL
3	668.26	36.51	-4.69	31.82	46.00	-14.18	Peak	HORIZONTAL
4	740.04	35.99	-3.15	32.84	46.00	-13.16	Peak	HORIZONTAL
5	813.76	33.19	-2.27	30.92	46.00	-15.08	Peak	HORIZONTAL
6	891.36	28.91	-0.94	27.97	46.00	-18.03	Peak	HORIZONTAL

Remark:

- 1 No further spurious emissions detected from the lowest internal frequency and 30MHz.
- 2 Measuring frequencies from the lowest internal frequency to the 1GHz.
- 3 Radiated emissions measured in frequency range from 30 MHz to 1000MHz were made with an instrument using Peak / QP detector mode.
- 4 Measurement result within this frequency range shown “ - ” in the table above means the reading of emissions are attenuated more than 20dB below the permissible limits or the field strength is too small to be measured.
- 5 The IF bandwidth of SPA between 30MHz to 1GHz was 100KHz, VBW=300KHz.

**Radiated Spurious Emission Measurement Result (above 1GHz)**

Operation Mode	: TX CH Low	Test Date	: 2013/12/31
Fundamental Frequency	: 2408 MHz	Test By	: Dino
Temp	: 25 °C	Hum.	: 60%

No	Freq MHz	Reading dBuV	Factor dB	Level dBuV/m	Limit dBuV/m	Over Limit dB	Remark	Pol V/H
1	4816.00	49.20	1.31	50.51	74.00	-23.49	Peak	VERTICAL
2	7224.00	37.76	8.24	46.00	74.00	-28.00	Peak	VERTICAL
1	4816.00	48.55	1.31	49.86	74.00	-24.14	Peak	HORIZONTAL
2	7224.00	34.86	8.24	43.10	74.00	-30.90	Peak	HORIZONTAL

Remark:

- 1 Measuring frequencies from the lowest internal frequency to the 10th of fundamental frequency
- 2 Field strength limits for frequency above 1000MHz are based on average limits. However, Peak mode field strength shall not exceed the average limits specified plus 20dB.
- 3 “F” denotes fundamental frequency; “H” denotes harmonics frequency. “S” denotes spurious frequency.
- 4 Measurement of data within this frequency range shown “ - ” in the table above means the reading of emissions are attenuated more than 20dB below the permissible limits or the field strength is too small to be measured.
- 5 Spectrum Peak mode IF bandwidth Setting : 1GHz- 26GHz, RBW= 1MHz, Sweep time= 200 ms., the VBW setting was 3 MHz.
- 6 Spectrum AV mode if bandwidth Setting : 1GHz- 26GHz, RBW= 1MHz, VBW= 10Hz, Sweep time= 200 ms.

### Radiated Spurious Emission Measurement Result (above 1GHz)

Operation Mode : TX CH Mid Test Date : 2013/12/31  
 Fundamental Frequency : 2440 MHz Test By : Dino  
 Temp : 25 °C Hum. : 60%

No	Freq MHz	Reading dBuV	Factor dB	Level dBuV/m	Limit dBuV/m	Over Limit dB	Remark	Pol V/H
1	4880.00	42.54	1.53	44.07	74.00	-29.93	Peak	VERTICAL
2	7320.00	32.70	8.30	41.00	74.00	-33.00	Peak	VERTICAL
1	4880.00	44.65	1.53	46.18	74.00	-27.82	Peak	HORIZONTAL
2	7320.00	38.18	8.30	46.48	74.00	-27.52	Peak	HORIZONTAL

Remark:

- 1 Measuring frequencies from the lowest internal frequency to the 10th of fundamental frequency
- 2 Field strength limits for frequency above 1000MHz are based on average limits. However, Peak mode field strength shall not exceed the average limits specified plus 20dB.
- 3 “F” denotes fundamental frequency; “H” denotes harmonics frequency. “S” denotes spurious frequency.
- 4 Measurement of data within this frequency range shown “ - ” in the table above means the reading of emissions are attenuated more than 20dB below the permissible limits or the field strength is too small to be measured.
- 5 Spectrum Peak mode IF bandwidth Setting : 1GHz- 26GHz, RBW= 1MHz, Sweep time= 200 ms., the VBW setting was 3 MHz.
- 6 Spectrum AV mode if bandwidth Setting : 1GHz- 26GHz, RBW= 1MHz, VBW= 10Hz, Sweep time= 200 ms.



**Radiated Spurious Emission Measurement Result (above 1GHz)**

Operation Mode : TX CH High Test Date : 2013/12/31  
 Fundamental Frequency : 2474 MHz Test By : Dino  
 Temp : 25 °C Hum. : 60%

No	Freq MHz	Reading dBuV	Factor dB	Level dBuV/m	Limit dBuV/m	Over Limit dB	Remark	Pol V/H
1	4948.00	46.14	1.77	47.91	74.00	-26.09	Peak	VERTICAL
2	7422.00	33.31	8.36	41.67	74.00	-32.33	Peak	VERTICAL
1	4948.00	46.54	1.77	48.31	74.00	-25.69	Peak	HORIZONTAL
2	7422.00	35.04	8.36	43.40	74.00	-30.60	Peak	HORIZONTAL

Remark:

- 1 Measuring frequencies from the lowest internal frequency to the 10th of fundamental frequency
- 2 Field strength limits for frequency above 1000MHz are based on average limits. However, Peak mode field strength shall not exceed the average limits specified plus 20dB.
- 3 “F” denotes fundamental frequency; “H” denotes harmonics frequency. “S” denotes spurious frequency.
- 4 Measurement of data within this frequency range shown “ - ” in the table above means the reading of emissions are attenuated more than 20dB below the permissible limits or the field strength is too small to be measured.
- 5 Spectrum Peak mode IF bandwidth Setting : 1GHz- 26GHz, RBW= 1MHz, Sweep time= 200 ms., the VBW setting was 3 MHz.
- 6 Spectrum AV mode if bandwidth Setting : 1GHz- 26GHz, RBW= 1MHz, VBW= 10Hz, Sweep time= 200 ms.

### Radiated Spurious Emission Measurement Result (Band Edge)

Operation Mode : Band Edge Test Date : 2013/12/31  
 Temp./Hum. : 25 °C / : 60% Test By : Dino

#### CH Low

No	Freq MHz	Reading dBuV	Factor dB	Level dBuV/m	Limit dBuV/m	Over Limit dB	Remark	Pol V/H
1	2396.40	53.40	-7.07	46.33	54.00	-7.67	Average	VERTICAL
2	2396.40	69.55	-7.07	62.48	74.00	-11.52	Peak	VERTICAL
3	2400.00	44.39	-7.07	37.32	54.00	-16.68	Average	VERTICAL
4	2400.00	59.47	-7.07	52.40	74.00	-21.60	Peak	VERTICAL
1	2395.50	55.38	-7.07	48.31	54.00	-5.69	Average	HORIZONTAL
2	2395.50	70.42	-7.07	63.35	74.00	-10.65	Peak	HORIZONTAL
3	2400.00	45.48	-7.07	38.41	54.00	-15.59	Average	HORIZONTAL
4	2400.00	60.43	-7.07	53.36	74.00	-20.64	Peak	HORIZONTAL

#### CH High

No	Freq MHz	Reading dBuV	Factor dB	Level dBuV/m	Limit dBuV/m	Over Limit dB	Remark	Pol V/H
1	2483.50	55.91	-6.90	49.01	74.00	-24.99	Peak	VERTICAL
2	2484.01	55.83	-6.90	48.93	74.00	-25.07	Peak	VERTICAL
1	2483.50	55.40	-6.90	48.50	74.00	-25.50	Peak	HORIZONTAL
2	2484.49	55.45	-6.89	48.56	74.00	-25.44	Peak	HORIZONTAL

Remark:

- 1 Measuring frequencies from the lowest internal frequency to the 10th of fundamental frequency
- 2 Field strength limits for frequency above 1000MHz are based on average limits. However, Peak mode field strength shall not exceed the average limits specified plus 20dB.
- 3 “F” denotes fundamental frequency; “H” denotes harmonics frequency. “S” denotes spurious frequency.
- 4 Measurement of data within this frequency range shown “ - ” in the table above means the reading of emissions are attenuated more than 20dB below the permissible limits or the field strength is too small to be measured.
- 5 Spectrum Peak mode IF bandwidth Setting : 1GHz- 26GHz, RBW= 1MHz, Sweep time= 200

ms., the VBW setting was 3 MHz.

- 6 Spectrum AV mode if bandwidth Setting : 1GHz- 26GHz, RBW= 1MHz, VBW= 10Hz, Sweep time= 200 ms.

## 7 20 dB Band Width Measurement

### 7.1 Measurement Procedure

1. The EUT was placed on a turn table which is 0.8m above ground plane.
2. Set EUT normal operating mode.
3. Set SPA Center Frequency = fundamental frequency, RBW = 100kHz, VBW = 300kHz, Span = 10MHz.
4. Set SPA Max hold. Mark peak, -20dB.

### 7.2 Test SET-UP (Block Diagram of Configuration)

Same as 4.2 Radiated Emission Measurement.

### 7.3 Measurement Equipment Used:

Same as 4.2 Radiated Emission Measurement.

### 7.4 Measurement Results:

2408 Channel = 2.17125MHz

2440 Channel = 2.17250MHz

2474 Channel = 2.17000MHz

Refer to attached data chart.

**20dB Bandwidth Test Data CH-Low**

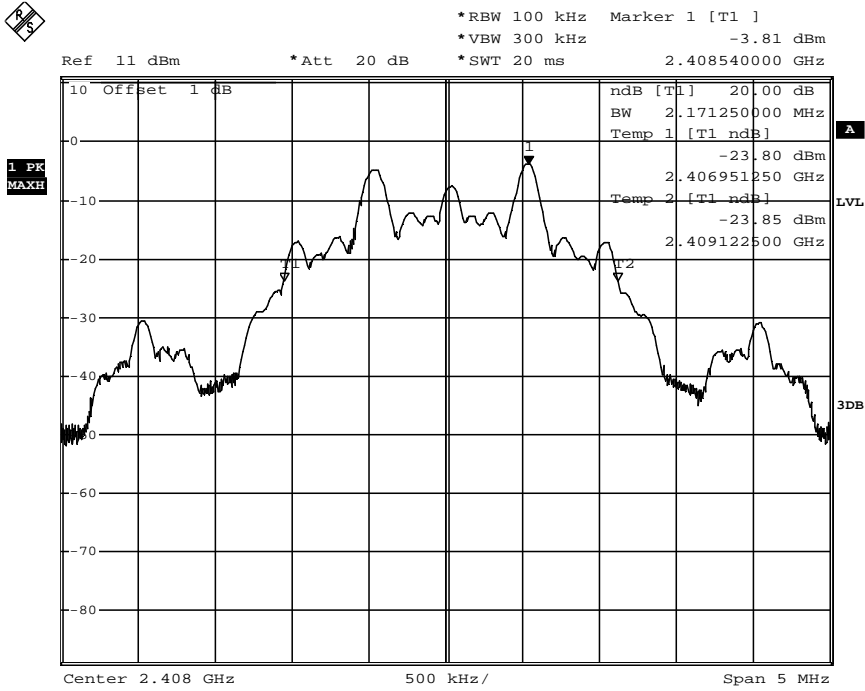

Date: 30.DEC.2013 13:45:01

**20dB Bandwidth Test Data CH-Mid**

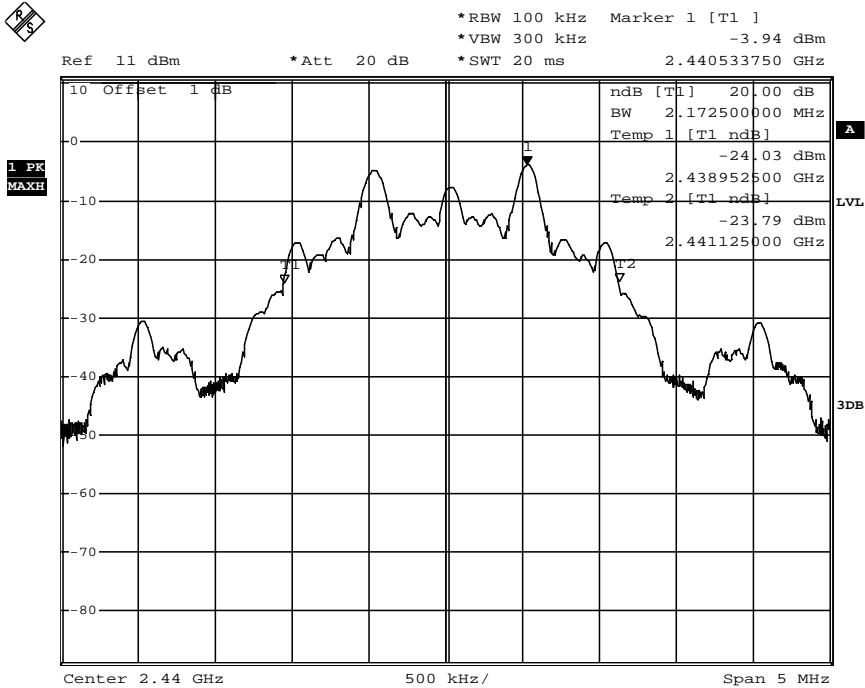

Date: 30.DEC.2013 13:46:24

**20dB Bandwidth Test Data CH-High**

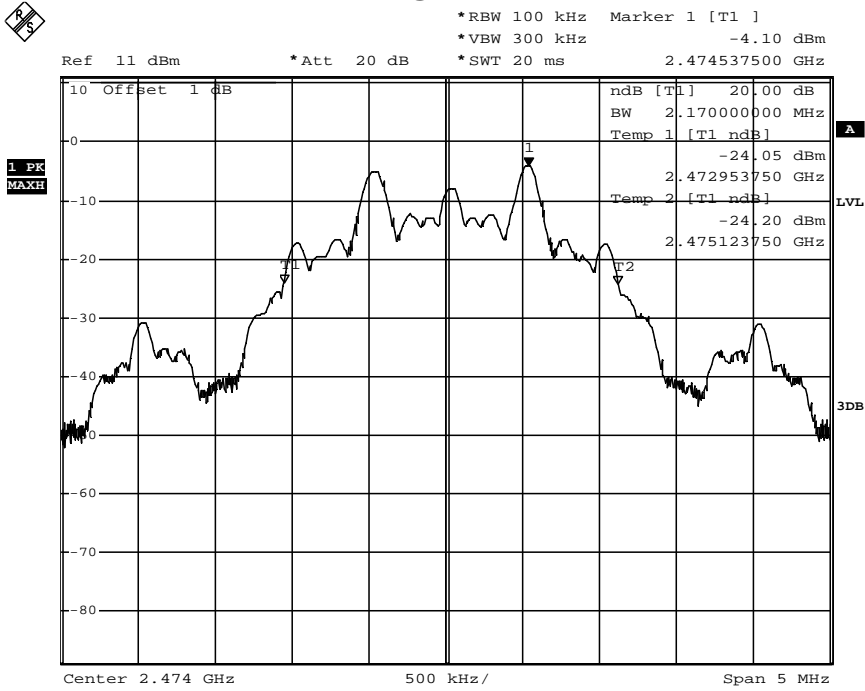

Date: 30.DEC.2013 13:49:52

# APPENDIX 1

## PHOTOGRAPHS OF SETUP

### Conducted Emission Setup Photos

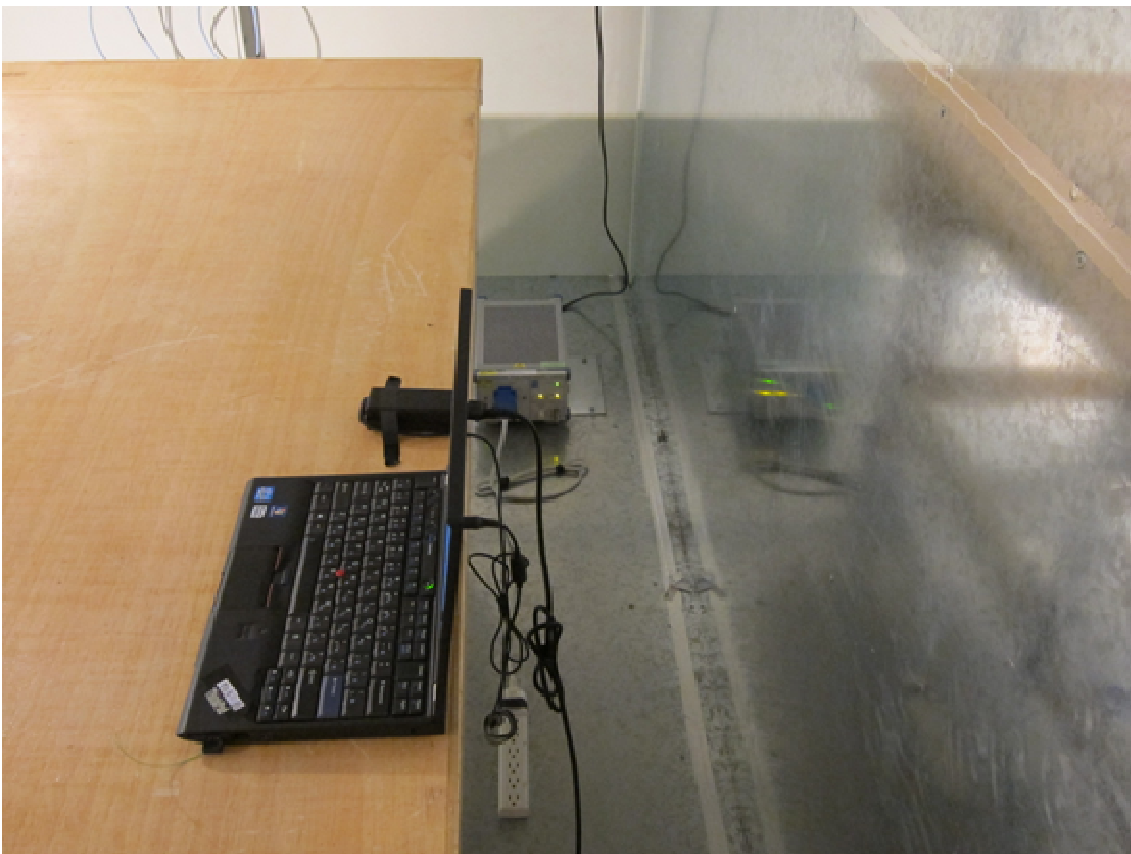



### Radiated Emission Setup Photos



## **APPENDIX 2**

# **PHOTOGRAPHS OF EUT**

***EUT 1***



***EUT 2***



**EUT 3**



**EUT 4**

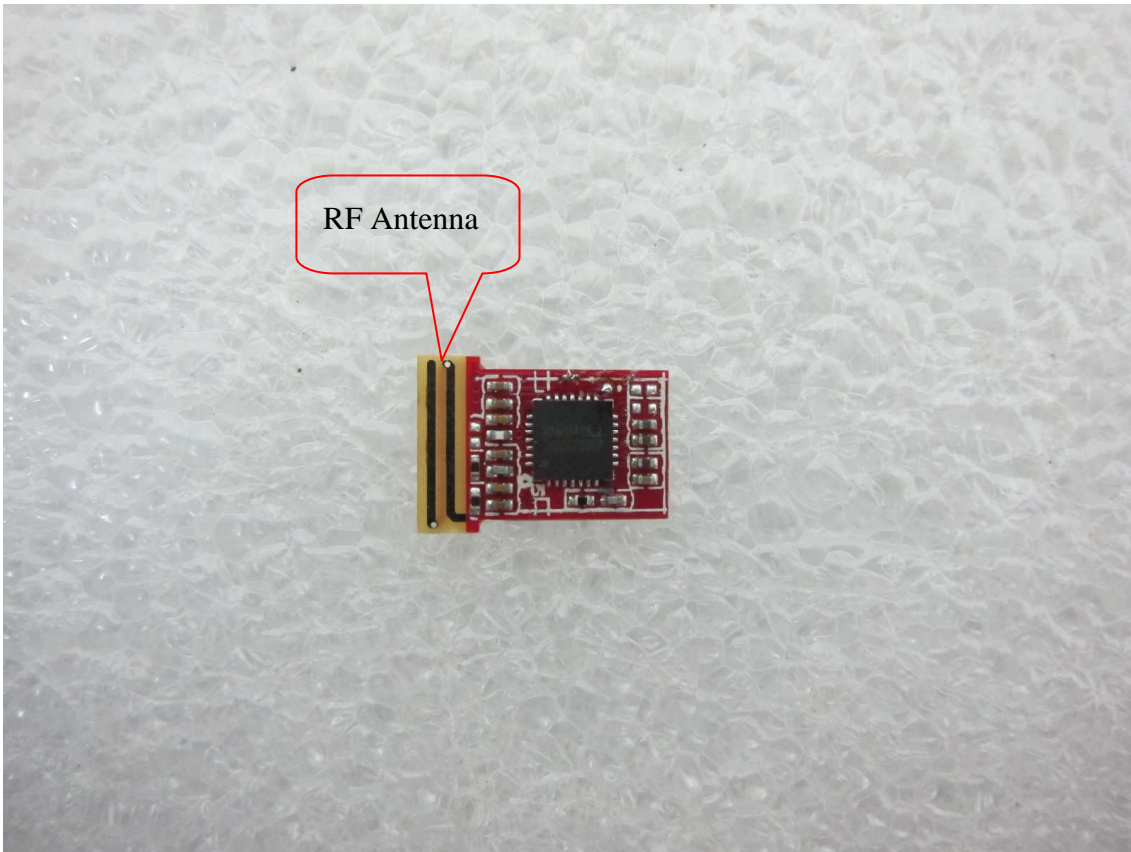

**EUT 5**



*~ End of Report ~*