



TEST REPORT

Product Name : PCI Wireless LAN Card

Model Number : GN-WPMG

Brand Name : GIGABYTE

FCC ID : JCK-GN-WPMG

Applicant : GIGA-BYTE TECHNOLOGY CO., LTD.

Address : No. 6, Bau Chiang Road, Hsin-Tien, Taipei Hsien,
Taiwan, R.O.C.

Received Date : September 21, 2004

Tested Date : September 21 ~ December 20, 2004

Notes :

1. This report will be invalid if duplicated or photocopied in part.
2. This report refers only to the specimen(s) submitted to testing, and be invalid as seperately used.
3. This report is invalid without examination stamp and signature of this institute.
4. The tested specimen(s) will be preserved for thirty days from the data issued.
5. The report must not be used to claim product certification, approval, or endorsement by NVLAP, NIST, or any agency of the federal government.





Ecom Sertech Corp.

Rm. 258, Bldg. 17, NO.195, Sec.4 Chung Hsing Rd., ChuTugn Chen, Hsinchu, Taiwan 310, R.O.C
TEL: 886-3-5918012 FAX: 886-3-5825720

FCC ID : JCK-GN-WPMG

Report No. : ER04-09-061FRF

Page 2 of 58

Test Report Certification

Product Name : PCI Wireless LAN Card
Model Number : GN-WPMG
Brand Name : GIGABYTE
FCC ID : JCK-GN-WPMG
Applicant : GIGA-BYTE TECHNOLOGY CO., LTD.

Measurement Standard :

FCC 47 C.F.R. Part 15, Subpart B and Subpart C (2004)
ANSI C63.4 (2003)

Tested By : Ken Tu, **Date** December 24, 2004
(Ken Tu)

Approved By : Chieh-De Tsai, **Date** December 24, 2004
(Chieh-De Tsai, Manager)



WE HEREBY CERTIFY THAT: The measurements shown in the attachment were made in accordance with the procedures indicated, and the energy emitted by the equipment was found to be within the limits applicable. We assume full responsibility for the accuracy and completeness of these measurements and vouch for the qualifications of all persons taking them.



TABLE OF CONTENTS

TITLE	PAGE NO.
1. GENERAL INFORMATION	5
1.1 General Statement.....	5
1.2 General Description of EUT & Power.....	5
1.3 Description of Peripherals.....	6
1.4 EUT & Peripherals Setup Diagram.....	7
1.5 EUT Operating Procedure.....	7
1.6 Description of Laboratory.....	8
1.7 Summary of Test Results.....	8
2. CONDUCTED POWERLINE TEST.....	9
2.1 Test Equipments	9
2.2 Test Setup	9
2.3 Conducted Power Line Emission Limit.....	10
2.4 Test Procedure	10
2.5 Uncertainty of Conducted Emission	10
2.6 Conducted RF Voltage Measurement.....	11-12
2.7 Photos of Conduction Test.....	13
3. RADIATED EMISSION TEST.....	14
3.1 Test Equipments	14
3.2 Test Setup	14
3.3 Radiation Limit.....	15
3.4 Test Procedures.....	16
3.5 Uncertainty of Radiated Emission	16
3.6 Radiated RF Noise Measurement	17-35
3.7 Photos of Open Site	36-37
4. 6dB BANDWIDTH MEASUREMENT	38
4.1 Test Equipments	38
4.2 Test Setup	38
4.3 Limits of 6dB Bandwidth Measurement.....	38
4.4 Test Procedure	38
4.5 Uncertainty of Conducted Emission	38
4.6 Test Results.....	39
4.7 Photo of 6db Bandwidth Measurement.....	40-41



TABLE OF CONTENTS

TITLE	PAGE NO.
5. MAXIMUM PEAK OUTPUT POWER	42
5.1 Test Equipments	42
5.2 Test Setup	42
5.3 Limits of Maximum Peak Output Power	42
5.4 Test Procedure	42
5.5 Uncertainty of Conducted Emission	423
5.6 Test Results.....	43
5.7 Photo of Maximum Peak Output Power Measurement	43-45
6. POWER SPECTRAL DENSITY MEASUREMENT	46
6.1 Test Equipments	46
6.2 Test Setup	46
6.3 Limits of Power Spectral Density Measurement	46
6.4 Test Procedure	47
6.5 Uncertainty of Conducted Emission	47
6.6 Test Results.....	47
6.7 Photo of Power Spectral Density Measurement	48-49
7. BAND EDGE MEASUREMENT	50
7.1 Test Equipments	50
7.2 Test Setup	50
7.3 Limits of Band Edge Emissions Measurement	50
7.4 Test Procedure	50
7.5 Uncertainty of Conducted Emission	50
7.6 Test Results.....	51
7.7 Photo of Band edge Measurement	52-55
8. ANTENNA REQUIREMENT	56
8.1 Standard Applicable.....	56
8.2 Antenna Connected Construction	56
9. RF EXPOSURE EVALUATION	57
9.1 Friis Formula.....	57
9.2 EUT Operating Condition.....	57
9.3 Test Result of RF Exposure Evaluation.....	58
9.3.1 Antenna Gain	58
9.3.2 Output Power into Antenna & RF Exposure Evaluation Distance	58



1. GENERAL INFORMATION

1.1 General Statement

MEASUREMENT DEVIATION : Comply with standard in full

TRACEABILITY : This test result is traceable to National or International std.

1.2 General Description of EUT & Power

Product Name	PCI Wireless LAN Card
Model Number	GN-WPMG
Frequency Range	2400MHz to 2483.5MHz
Frequency Channel	2412MHz + 5×n (MHz), n=0, 1, 2,.....10
Channel Number	11
Channel Spacing	5MHz
Air Data Rate	54Mbps (802.11g Mode), 11Mbps(802.11b Mode)
Type of Modulation	802.11b : DSSS(CCK, DQPSK, DBPSK) 802.11g : OFDM(64QAM, 16AQM, QPSK, BPSK)
Frequency Selection	by software / firmware
Transmitter Classification	mobile device
EUT Description	2.4GHz (Direct Sequence Spread Spectrum and Orthogonal Frequency Division Multiplex) Data Transceiver for WLAN application
Antenna Type	Dipole Antenna, Antenna Gain : 1.8dBi Connector : Reversed SMA.
Power Source	3.3VDC (From PC)



1.3 Description of Peripherals

(1) PC

MANUFACTURER : HP CORP.
MODEL NUMBER : t123d
SERIAL NUMBER : TW31720220
INPUT POWER : 100-127V, 200-240V, 2.0A, 50/60Hz
OUTPUT POWER : -----

(2) Printer

MANUFACTURER : HP CORP.
MODEL NUMBER : Deskjet 948C
SERIAL NUMBER : CN19T6S011
FCC ID : DOC
POWER SOURCE : 100-240VAC,50/60Hz,0.7A
SIGNAL CABLE : Shielded , Undetachable , 1.8m

(3) Monitor

MANUFACTURER : HP CORP.
MODEL NUMBER : D8894A
SERIAL NUMBER : CN94689371
INPUT POWER : 100-240VAC, 50/60Hz, 1.5A
OUTPUT POWER : -----

(4) Keyboard

MANUFACTURER : HP CORP.
MODEL NUMBER : SK-2502C
SERIAL NUMBER : M991138390
INPUT POWER : 5VDC (From PC)
OUTPUT POWER : -----

(5) Mouse

MANUFACTURER : HP CORP.
MODEL NUMBER : C3751-60201
SERIAL NUMBER : LZR95050644
INPUT POWER : 5VDC (From PC)
OUTPUT POWER : -----

1.4 EUT & Peripherals Setup Diagram

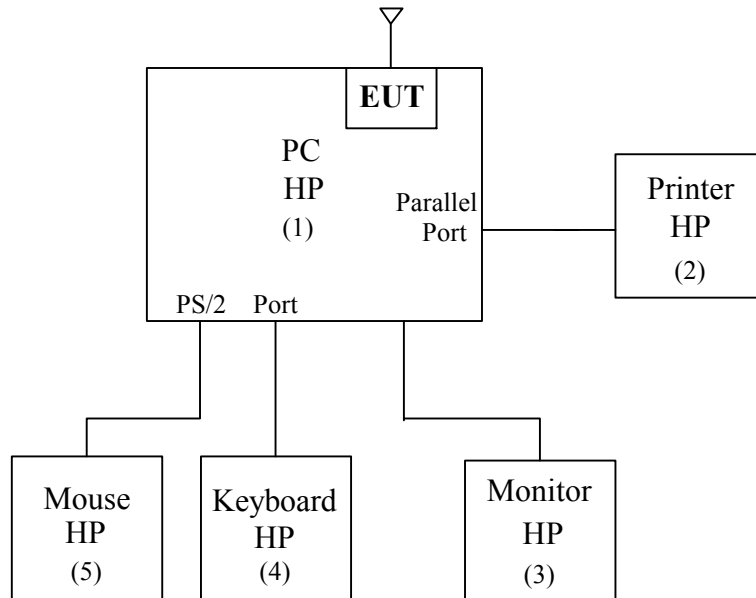

The indicated numbers (1)(2).....,please refer to item 1.3

1.5 EUT Operating Procedure

1. Install PCI Wireless LAN Card test program for HP computer.
2. Press DutApiclass test program to implement continue TX or RX mode.
3. Set the test software of doing something as follows.
4. Set TX 802.11b mode an order.
 - (1) 75 : Hardware Initalization
 - (2) 22 1 18 : Set channel and power at Antenna with calibration Data.
1 = Channel 1, 18 = 18dBm
 - (3) 25 1 4 : Sets device to duty cycle transmit at 11Mbps.
1 = Channel 1, 4 = 11Mbps
 - (4) 25 : disable
 - (5) 17 1 4 : Set the device for continuous transmission.
1 = Channel 1, 4 = 11Mbps
5. Set TX 802.11g mode an order.
 - (1) 75 : Hardware Initalization
 - (2) 22 1 12 : Set channel and power at Antenna with calibration Data.
1 = Channel 1, 12 = 12dBm
 - (3) 25 1 13 : Sets device to duty cycle transmit at 54Mbps.
 - (4) 25 : disable
 - (5) 17 1 13 : Set the device for continuous transmission.
1 = Channel 1, 13 = 54Mbps
6. Set RX mode an order.
 - (1) 75 : Hardware Initalization
 - (2) 12 1 : Set RF channel
 - (3) 31 : SETS RX FER test.



1.6 Description of Laboratory

SITE DESCRIPTION

FCC Certificate NO. : 90585
BSMI Certificate NO. : SL2-IN-E-0002
NVLAP Lab Code : 200118-0
CNLA Certificate NO. : CNLA-ZL97018E
VCCI Certificate NO. : R-1189, C-1250
TÜV Rheinland Certificate NO. : 10008375

NAME OF SITE : Ecom Sertech Corp. Hsin-Chu Lab.
(Spin-off from ITRI / ERSO on Apr. 01, 2003)
SITE LOCATION : Rm.258, Bldg.17, NO.195 , Sec. 4, Chung Hsing Rd.,
Chu-Tung Chen. Hsin-Chu, Taiwan 310 R.O.C.

1.7 Summary of Test Results

The EUT has been tested according to the following specifications :

APPLIED STANDARD : FCC 47 C.F.R. Part 15, Subpart B and Subpart C			
Standard Section	Test Item and Limit	Result	REMARK
15.107 15.207	AC Power Conducted Emission Limit : Sec 15.107	PASS	Meet the requirement of limit
15.247(a)(2)	Spectrum Bandwidth of a Orthogonal Frequency Division Multiplex System Limit : 6dB bandwidth > 500KHz	PASS	Meet the requirement of limit
15.247(b)	Maximum Peak Output Power Limit : max. 30dBm	PASS	Meet the requirement of limit
15.109 15.205 15.209	Transmitter Radiated Emissions Limit : Table 15.209	PASS	Meet the requirement of limit
15.247(e)	Power Spectral Density Limit : max. 8dBm	PASS	Meet the requirement of limit
15.247(d)	Out of Band Emission and Restricted Band Radiation Limit:20dB less than peak value of fundamental frequency Restricted band Limit:Table 15.209	PASS	Meet the requirement of limit



2. CONDUCTED POWERLINE TEST

2.1 Test Equipments

The following test equipments are used during the conducted powerline tests :

Manufacturer or Type	Model No.	Serial No.	Date of Calibration	Calibration Period	Remark
HP SPECTRUM ANALYZER & DISPLAY	8594E	3801A05627	April 26, 2004	1 Year	PRETEST
SOLAR ISOLATION TRANSFORMER	7032-1	N/A	N/A	N/A	FINAL
EMCO L.I.S.N.	3850/2	9311-1025 9401-1028	January 08, 2004 For Characteristic impedance May 18, 2004 For Insertion loss	1 Year	FINAL
R & S TEST RECEIVER	ESHS 30	838550/003	February 11, 2004	1 Year	FINAL
KEENE SHIELDED ROOM	5983	No.1	N/A	N/A	FINAL
R & S PULSE LIMIT	EHS3Z2	357.8810.52	July 10, 2004	1 Year	FINAL
N TYPE COAXIAL CABLE	-----	-----	July 10, 2004	1 Year	FINAL
50Ω TERMINATOR	-----	-----	July 10, 2004	1 Year	FINAL

2.2 Test Setup

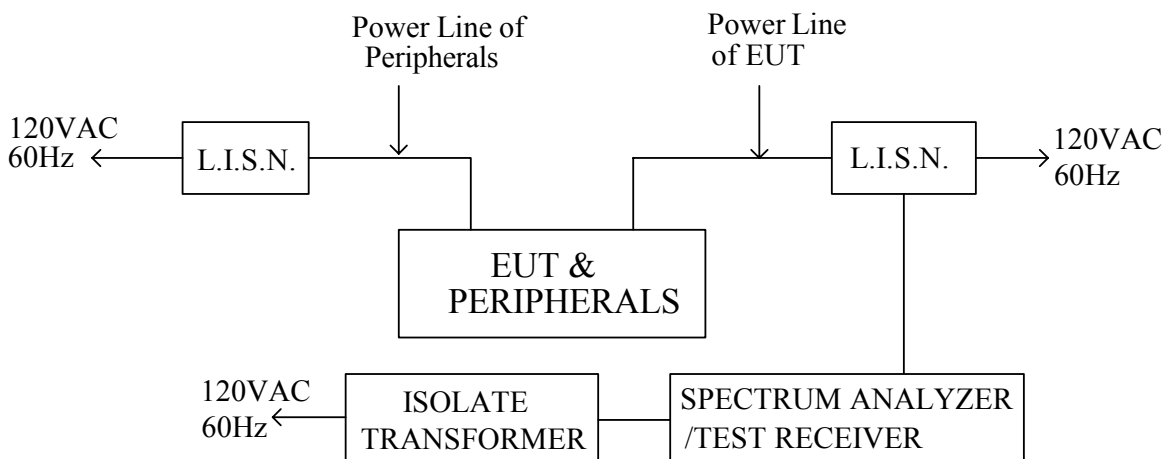



2.3 Conducted Power Line Emission Limit

For unintentional device, according to § 15.107(a) Line Conducted Emission Limits is as following :

Frequency (MHz)	Maximum RF Line Voltage (dB μ v)			
	CLASS A		CLASS B	
	Q.P.	Ave.	Q.P.	Ave.
0.15 - 0.50	79	66	66-56	56-46
0.50 - 5.00	73	60	56	46
5.00 - 30.0	73	60	60	50

For intentional device, according to § 15.207(a) Line Conducted Emission Limit is same as above table.

2.4 Test Procedure

The test procedure is performed in a 12ft×12ft×8ft(L×W×H) shielded room. The EUT along with its peripherals were placed on a 1.0m(W)× 1.5m(L) and 0.8m in height wooden table and the EUT was adjusted to maintain a 0.4 meter space from a vertical reference plane. The EUT was connected to power mains through a line impedance stabilization network (LISN) which provides 50 ohm coupling impedance for measuring instrument and the chasis ground was bounded to the horizontal ground plane of shielded room. All peripherals were connected to the second LISN and the chasis ground also bounded to the horizontal ground plane of shielded room. The excess power cable between the EUT and the LISN was bundled. The power cables of peripherals were unbundled. All connecting cables of EUT and peripherals were moved to find the maximum emission.

2.5 Uncertainty of Conducted Emission

The uncertainty of conducted emission is ±1.36dB.



2.6 Conducted RF Voltage Measurement

The frequency spectrum from 0.15 MHz to 30 MHz was investigated. All emissions not reported are much lower than the prescribed limits.

Company	GIGA-BYTE TECHNOLOGY CO., LTD.	Test Date	2004/11/29
Product Name	PCI Wireless LAN Card	Test By	Ken Tu
Model Name	GN-WPMG	TEMP & Humidity	21.6°C, 52%

LINE

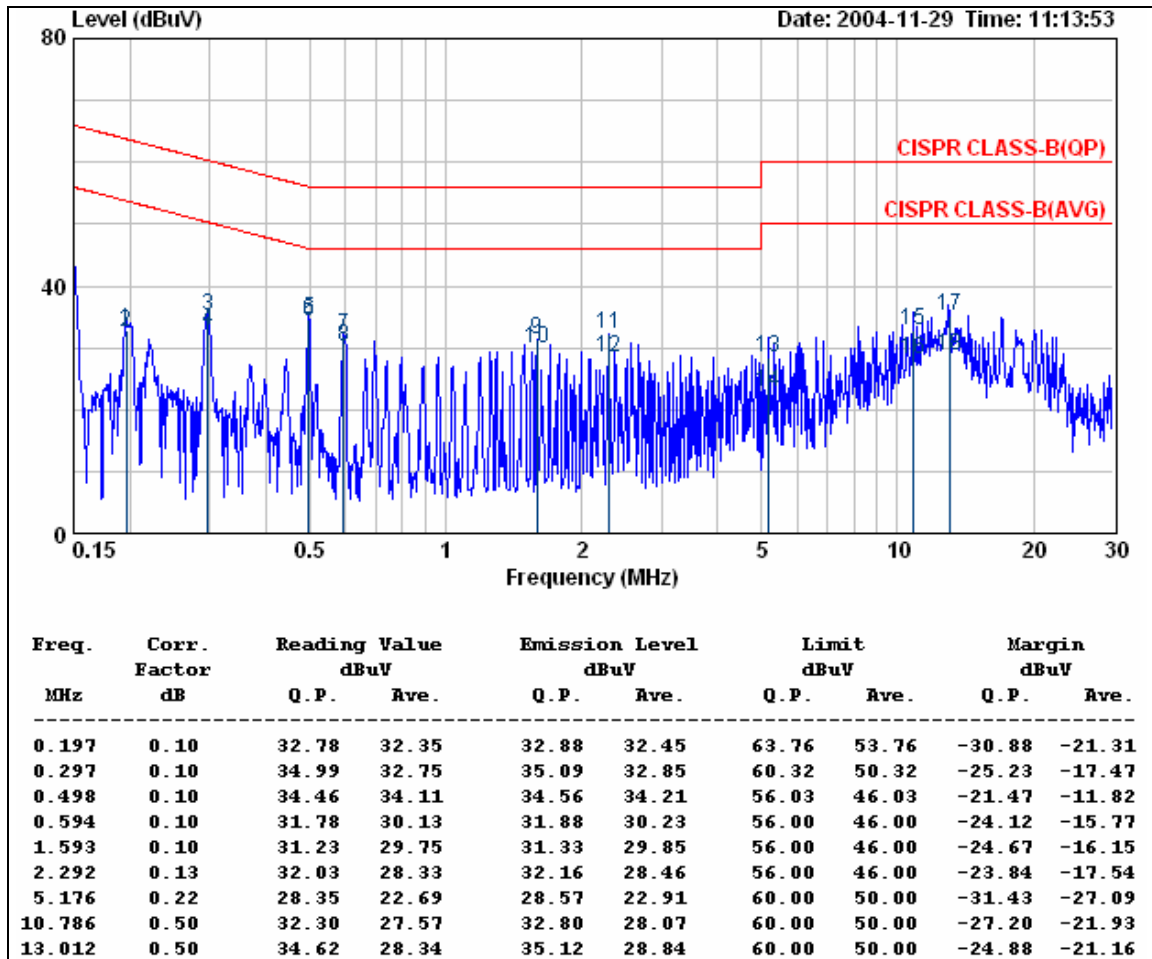

REMARKS :

1. Correction Factor = Insertion loss + cable loss
2. Margin value = Emission level – Limit value
3. The EUT can be operated in transmitting, stand-by and receiving mode. After preliminary scan, EUT in transmitting mode has highest emission. The EUT was set in transmitting mode at final test to get the worst case test results.



The frequency spectrum from 0.15 MHz to 30 MHz was investigated. All emissions not reported are much lower than the prescribed limits.

Company	GIGA-BYTE TECHNOLOGY CO., LTD.	Test Date	2004/11/29
Product Name	PCI Wireless LAN Card	Test By	Ken Tu
Model Name	GN-WPMG	TEMP & Humidity	21.6°C, 52%

NEUTRAL

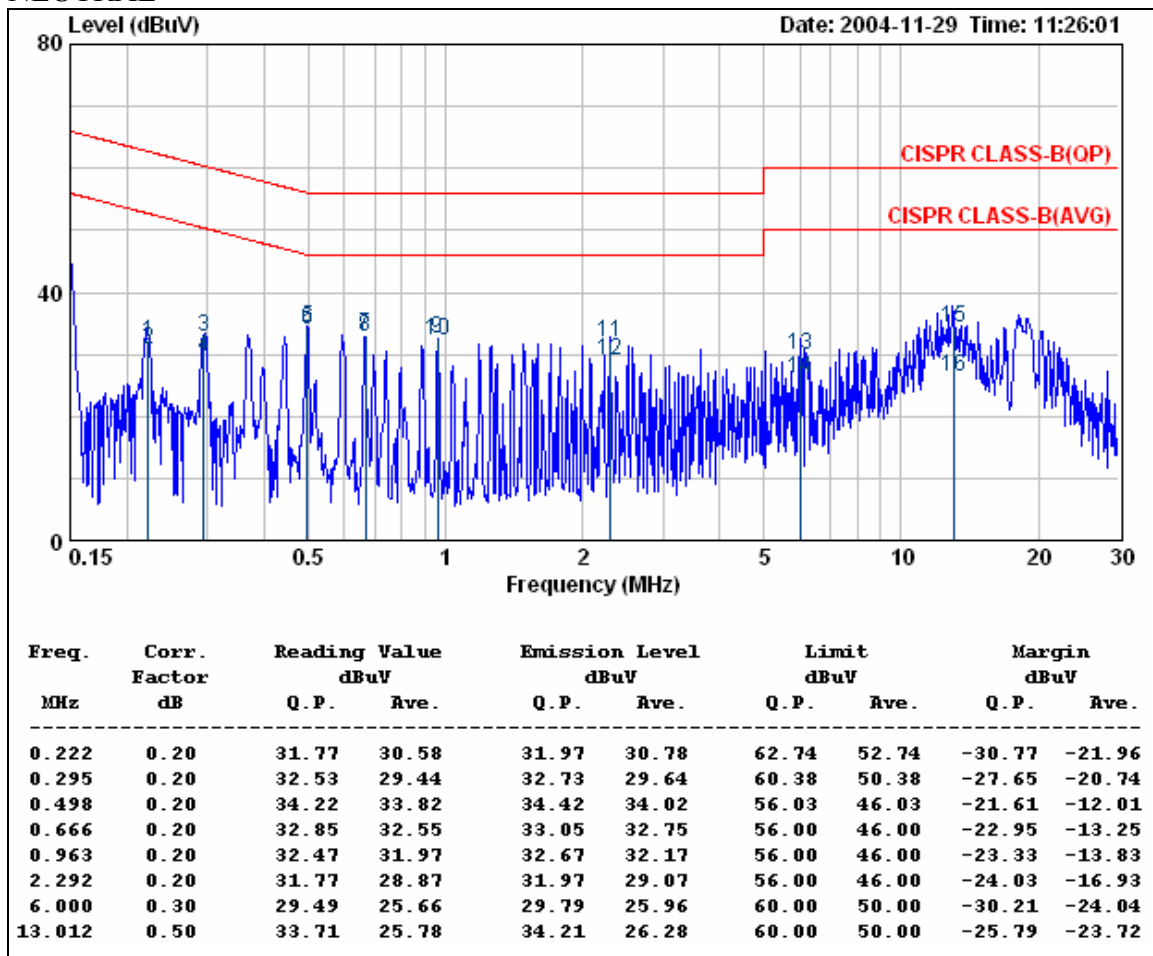

REMARKS :

1. Correction Factor = Insertion loss + cable loss
2. Margin value = Emission level – Limit value
3. The EUT can be operated in transmitting, stand-by and receiving mode. After preliminary scan, EUT in transmitting mode has highest emission. The EUT was set in transmitting mode at final test to get the worst case test results.

2.7 Photos of Conduction Test



3. RADIATED EMISSION TEST

3.1 Test Equipments

The following test equipments are utilized in making the measurements contained in this report.

Manufacturer or Type	Model No	Serial No	Date of Calibration	Calibration Period	Remark
CHASE BI-LOG ANTENNA	CBL6112B	2421	June 15, 2004	1 Year	FINAL
R/S SPECTRUM ANALYZER	FSEK30	835253/002	September 06, 2004	1 Year	FINAL
OPEN SITE	-----	No.2	May 07, 2004	1 Year	FINAL
N TYPE COAXIAL CABLE	CHA9525	4	June 03, 2004	1 Year	FINAL
Horn Antenna	AH-118	10089	April 09, 2004	1 Year	FINAL
HP Pre-amplifier	8449B	3008A01471	November 24, 2004	1 Year	FINAL
HP High pass filter	84300/80038	002	CAL. ON USE	1 Year	FINAL
Horn Antenna	AH-840	3077	February 25, 2004	1 Year	FINAL

3.2 Test Setup

The diagram below shows the test setup that is utilized to make the measurements for emission below 1GHz.

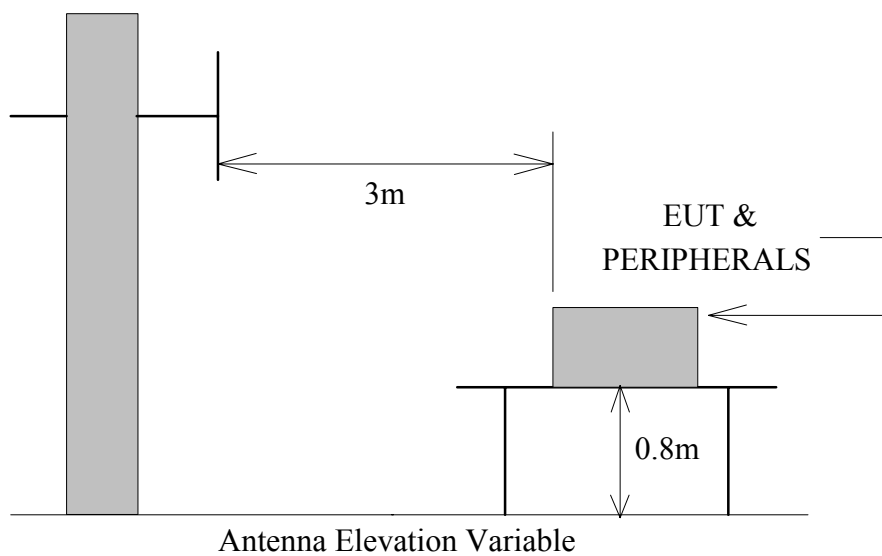

The diagram below shows the test setup that is utilized to make the measurements for emission above 1GHz.

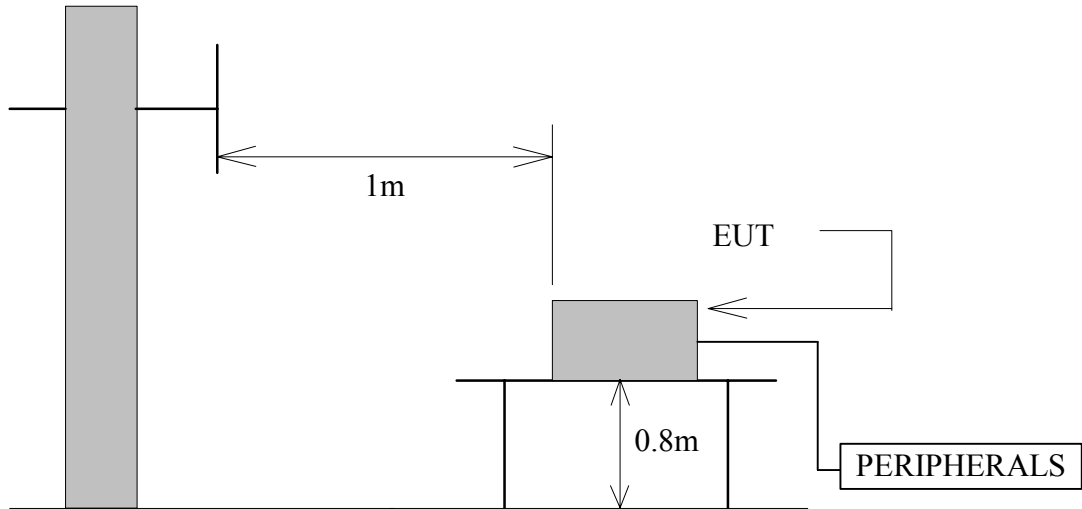

Antenna Elevation Variable

3.3 Radiation Limit

For unintentional device, according to § 15.109(a), except for Class A digital devices, the field strength of radiated emissions from unintentional radiators at a distance of 3 meters shall not exceed the following values :

Frequency (MHz)	Distance (Meters)	Radiated (dB μ V/M)	Radiated (μ V/M)
30-88	3	40.0	100
88-216	3	43.5	150
216-960	3	46.0	200
Above 960	3	54.0	500

For intentional device, according to § 15.209(a), the general requirement of field strength of radiated emissions from intentional radiators at a distance of 3 meters shall not exceed the above table. According to § 15.247(d), in any 100kHz bandwidth outside the frequency band in which the EUT is operating, the radiofrequency power that is produced by the intentional radiator shall be at least 20dB below that in the 100kHz bandwidth within the band that contains the highest level of desired power.



3.4 Test Procedures

- a. The EUT was placed on the top of a rotating table 0.8 meters above the ground at a 10 meter open area test site. The table was rotated 360 degrees to determine the position of the highest radiation.
- b. During performing radiated emission below 1GHz, the EUT was set 3 meters away from the interference-receiving antenna, which was mounted on the top of a variable-height antenna tower. During performing radiated emission above 1GHz, the EUT was set 1 meters away from the interference-receiving antenna.
- c. The antenna is a broadband antenna, and its height is varied from one meter to four meters above the ground to determine the maximum value of the field strength. Both horizontal and vertical polarization of the antenna are set to make the measurement.
- d. For each suspected emission, the EUT was arranged to its worst case and then the antenna was tuned to heights from 1 meter to 4 meters and the table was turned from 0 degrees to 360 degrees to find the maximum reading.
- e. The test-receiver system was set to Peak Detect Function and Specified Bandwidth with Maximum Hold Mode.
- f. If the emission level of the EUT in peak mode was 10 dB lower than the limit specified, then testing could be stopped and the peak values of the EUT would be reported. Otherwise the emissions that did not have 10 dB margin would be re-tested one by one using peak, quasi-peak or average method as specified and then reported in a data sheet.

NOTE :

1. The resolution bandwidth and video bandwidth of test receiver/spectrum analyzer is 120 KHz for Peak detection (PK) and Quasi-peak detection (QP) at frequency below 1GHz.
2. The resolution bandwidth and video bandwidth of test receiver/spectrum analyzer is 1 MHz for Peak detection and frequency above 1GHz.
3. The resolution bandwidth of test receiver/spectrum analyzer is 1 MHz and the video bandwidth is 10 Hz for Average detection (AV) at frequency above 1GHz.

3.5 Uncertainty of Radiated Emission

The uncertainty of radiated emission is ± 2.72 dB.



Ecom Sertech Corp.

Rm. 258, Bldg. 17, NO.195, Sec.4 Chung Hsing Rd., ChuTugn Chen, Hsinchu, Taiwan 310, R.O.C
TEL: 886-3-5918012 FAX: 886-3-5825720

FCC ID : JCK-GN-WPMG

Report No. : ER04-09-061FRF

Page 17 of 58

3.6 Radiated RF Noise Measurement

The frequency spectrum from 30 MHz to 1000 MHz was investigated. All emissions not reported are much lower than the prescribed limits.

All readings are quasi-peak values.

Company	GIGA-BYTE TECHNOLOGY CO., LTD.	Test Date	2004/11/29
Product Name	PCI Wireless LAN Card	Test By	Ken Tu
Model Name	GN-WPMG	TEMP & Humidity	21.6°C, 52%

Frequency (MHz)	Antenna Factor (dB/m)	Cable Loss (dB)	Meter Reading at 3m(dBμV)		Limits (dBμV/m)	Emission Level at 3m(dBμV/m)	
			Horizontal	Vertical		Horizontal	Vertical
30.00	17.01	0.97	*	*	40.00	*	*
196.60	9.96	3.10	0.50	9.60	43.50	13.56	22.66
339.08	15.42	4.51	5.90	10.80	46.00	25.84	30.74
400.28	18.41	4.85	0.80	5.50	46.00	24.06	28.76
432.05	18.22	4.96	2.30	4.40	46.00	25.48	27.58
504.06	17.86	5.21	1.80	1.90	46.00	24.87	24.97
528.07	18.07	5.32	1.70	1.80	46.00	25.08	25.18
610.32	18.75	5.71	2.50	0.80	46.00	26.97	25.27
712.04	19.64	6.33	2.20	3.80	46.00	28.18	29.78
830.72	20.96	6.94	0.50	3.00	46.00	28.39	30.89
847.66	21.06	7.01	0.40	3.10	46.00	28.47	31.17
915.48	21.45	7.31	0.30	3.40	46.00	29.06	32.16
1000.00	27.43	7.66	*	*	54.00	*	*

REMARKS :

- * Undetectable
- Emission level (dBμV/m) = Antenna Factor (dB/m) + Cable loss (dB) + Meter Reading (dBμV).
- According to technical experiences, all spurious emission at channel 1,6,11 are almost the same below 1GHz,so that the channel 1 was chosen as representative in final test.



Ecom Sertech Corp.

Rm. 258, Bldg. 17, NO.195, Sec.4 Chung Hsing Rd., ChuTugn Chen, Hsinchu, Taiwan 310, R.O.C
 TEL: 886-3-5918012 FAX: 886-3-5825720

FCC ID : JCK-GN-WPMG
 Report No. : ER04-09-061FRF
 Page 18 of 58

The frequency spectrum above 1 GHz for Receiver was investigated. All emissions not reported are much lower than the prescribed limits. Readings are both peak and average values.

Company	GIGA-BYTE TECHNOLOGY CO., LTD.	Test Date	2004/12/03
Product Name	PCI Wireless LAN Card	Test By	Ken Tu
Model Name	GN-WPMG	TEMP & Humidity	22.3°C, 81%

CH1 RX				Measurement Distance at 1m Horizontal polarity							
Freq. (MHz)	Reading (dBμV)	AF (dBμV)	Cable (dB)	Pre-amp (dB)	Dist (dB)	Filter (dB)	Level (dBμV/m)	Limit (dBμV/m)	Margin (dB)	Mark (P/Q/A)	Height (Meter)
4075.95	44.63	32.55	4.84	34.90	9.50	0.00	37.63	74	-36.37	P	1.0
4075.95	32.34	32.55	4.84	34.90	9.50	0.00	25.34	54	-28.66	A	1.0
6114.02	44.52	37.33	6.42	34.30	9.50	0.00	44.47	74	-29.53	P	1.0
6114.02	32.42	37.33	6.42	34.30	9.50	0.00	32.37	54	-21.63	A	1.0
8152.01	45.14	39.45	7.37	35.94	9.50	0.00	46.51	74	-27.49	P	1.0
8152.01	34.52	39.45	7.37	35.94	9.50	0.00	35.89	54	-18.11	A	1.0

1. AF: Antenna Factor, Cable: Cable Loss, Pre-Amp: Preamplifier gain.
2. Spectrum analyzer setting P(Peak): RBW=1MHz, VBW=1MHz, A(Average): RBW=1MHz, VBW=10Hz
3. Dist : correction to extra plate reading to 3m specification distance 1m measurement distance = -9.5dB
4. The result basic equation calculation as follow :

$$\text{Level} = \text{Reading} + \text{AF} + \text{Cable} - \text{Preamp} + \text{Filter} - \text{Dist}, \text{Margin} = \text{Level} - \text{Limit}$$
5. The test limit is 3M limit.
6. The frequency was searched to 18GHz.
7. The other emission levels were very low against the limit.



Ecom Sertech Corp.

Rm. 258, Bldg. 17, NO.195, Sec.4 Chung Hsing Rd., ChuTugn Chen, Hsinchu, Taiwan 310, R.O.C
 TEL: 886-3-5918012 FAX: 886-3-5825720

FCC ID : JCK-GN-WPMG
 Report No. : ER04-09-061FRF
 Page 19 of 58

The frequency spectrum above 1 GHz for Receiver was investigated. All emissions not reported are much lower than the prescribed limits. Readings are both peak and average values.

Company	GIGA-BYTE TECHNOLOGY CO., LTD.	Test Date	2004/12/03
Product Name	PCI Wireless LAN Card	Test By	Ken Tu
Model Name	GN-WPMG	TEMP & Humidity	22.3°C, 81%

CH1 RX				Measurement Distance at 1m Vertical polarity							
Freq. (MHz)	Reading (dBμV)	AF (dBμV)	Cable (dB)	Pre-amp (dB)	Dist (dB)	Filter (dB)	Level (dBμV/m)	Limit (dBμV/m)	Margin (dB)	Mark (P/Q/A)	Height (Meter)
4075.97	43.85	32.55	4.84	34.90	9.50	0.00	36.85	74	-37.15	P	1.0
4075.97	32.19	32.55	4.84	34.90	9.50	0.00	25.19	54	-28.81	A	1.0
6113.99	44.29	37.33	6.42	34.30	9.50	0.00	44.24	74	-29.76	P	1.0
6113.99	32.48	37.33	6.42	34.30	9.50	0.00	32.43	54	-21.57	A	1.0
8151.98	44.89	39.45	7.37	35.94	9.50	0.00	46.26	74	-27.74	P	1.0
8151.98	34.11	39.45	7.37	35.94	9.50	0.00	35.48	54	-18.52	A	1.0

1. AF: Antenna Factor, Cable: Cable Loss, Pre-Amp: Preamplifier gain.
2. Spectrum analyzer setting P(Peak): RBW=1MHz, VBW=1MHz, A(Average): RBW=1MHz, VBW=10Hz
3. Dist : correction to extra plate reading to 3m specification distance 1m measurement distance = -9.5dB
4. The result basic equation calculation as follow :

$$\text{Level} = \text{Reading} + \text{AF} + \text{Cable} - \text{Preamp} + \text{Filter} - \text{Dist}, \text{Margin} = \text{Level} - \text{Limit}$$
5. The test limit is 3M limit.
6. The frequency was searched to 18GHz.
7. The other emission levels were very low against the limit.



Ecom Sertech Corp.

Rm. 258, Bldg. 17, NO.195, Sec.4 Chung Hsing Rd., ChuTugn Chen, Hsinchu, Taiwan 310, R.O.C
TEL: 886-3-5918012 FAX: 886-3-5825720

FCC ID : JCK-GN-WPMG
Report No. : ER04-09-061FRF
Page 20 of 58

The frequency spectrum above 1 GHz for Receiver was investigated. All emissions not reported are much lower than the prescribed limits. Readings are both peak and average values.

Company	GIGA-BYTE TECHNOLOGY CO., LTD.	Test Date	2004/12/03
Product Name	PCI Wireless LAN Card	Test By	Ken Tu
Model Name	GN-WPMG	TEMP & Humidity	22.3°C, 81%

CH6 RX				Measurement Distance at 1m Horizontal polarity							
Freq. (MHz)	Reading (dBμV)	AF (dBμV)	Cable (dB)	Pre-amp (dB)	Dist (dB)	Filter (dB)	Level (dBμV/m)	Limit (dBμV/m)	Margin (dB)	Mark (P/Q/A)	Height (Meter)
4126.01	44.67	32.52	4.86	34.90	9.50	0.00	37.65	74	-36.35	P	1.0
4126.01	33.04	32.52	4.86	34.90	9.50	0.00	26.02	54	-27.98	A	1.0
6189.02	44.19	37.48	6.43	34.30	9.50	0.00	44.30	74	-29.70	P	1.0
6189.02	32.73	37.48	6.43	34.30	9.50	0.00	32.84	54	-21.16	A	1.0
8251.99	45.03	39.35	7.45	35.18	9.50	0.00	47.14	74	-26.86	P	1.0
8251.99	34.17	39.35	7.45	35.18	9.50	0.00	36.28	54	-17.72	A	1.0

1. AF: Antenna Factor, Cable: Cable Loss, Pre-Amp: Preamplifier gain.
2. Spectrum analyzer setting P(Peak): RBW=1MHz, VBW=1MHz, A(Average): RBW=1MHz, VBW=10Hz
3. Dist : correction to extra plate reading to 3m specification distance 1m measurement distance = -9.5dB
4. The result basic equation calculation as follow :
Level = Reading + AF + Cable - Preamp + Filter - Dist, Margin = Level - Limit
5. The test limit is 3M limit.
6. The frequency was searched to 18GHz.
7. The other emission levels were very low against the limit.



Ecom Sertech Corp.

Rm. 258, Bldg. 17, NO.195, Sec.4 Chung Hsing Rd., ChuTugn Chen, Hsinchu, Taiwan 310, R.O.C
 TEL: 886-3-5918012 FAX: 886-3-5825720

FCC ID : JCK-GN-WPMG
 Report No. : ER04-09-061FRF
 Page 21 of 58

The frequency spectrum above 1 GHz for Receiver was investigated. All emissions not reported are much lower than the prescribed limits. Readings are both peak and average values.

Company	GIGA-BYTE TECHNOLOGY CO., LTD.	Test Date	2004/12/03
Product Name	PCI Wireless LAN Card	Test By	Ken Tu
Model Name	GN-WPMG	TEMP & Humidity	22.3°C, 81%

CH6 RX				Measurement Distance at 1m Vertical polarity							
Freq. (MHz)	Reading (dBμV)	AF (dBμV)	Cable (dB)	Pre-amp (dB)	Dist (dB)	Filter (dB)	Level (dBμV/m)	Limit (dBμV/m)	Margin (dB)	Mark (P/Q/A)	Height (Meter)
4126.00	44.46	32.52	4.86	34.90	9.50	0.00	37.44	74	-36.56	P	1.0
4126.00	33.36	32.52	4.86	34.90	9.50	0.00	26.34	54	-27.66	A	1.0
6189.02	44.57	37.48	6.43	34.30	9.50	0.00	44.68	74	-29.32	P	1.0
6189.02	33.07	37.48	6.43	34.30	9.50	0.00	33.18	54	-20.82	A	1.0
8252.01	44.46	39.35	7.45	35.18	9.50	0.00	46.57	74	-27.43	P	1.0
8252.01	33.80	39.35	7.45	35.18	9.50	0.00	35.91	54	-18.09	A	1.0

1. AF: Antenna Factor, Cable: Cable Loss, Pre-Amp: Preamplifier gain.
2. Spectrum analyzer setting P(Peak): RBW=1MHz, VBW=1MHz, A(Average): RBW=1MHz, VBW=10Hz
3. Dist : correction to extra plate reading to 3m specification distance 1m measurement distance = -9.5dB
4. The result basic equation calculation as follow :

$$\text{Level} = \text{Reading} + \text{AF} + \text{Cable} - \text{Preamp} + \text{Filter} - \text{Dist}, \text{Margin} = \text{Level} - \text{Limit}$$
5. The test limit is 3M limit.
6. The frequency was searched to 18GHz.
7. The other emission levels were very low against the limit.



Ecom Sertech Corp.

Rm. 258, Bldg. 17, NO.195, Sec.4 Chung Hsing Rd., ChuTugn Chen, Hsinchu, Taiwan 310, R.O.C
 TEL: 886-3-5918012 FAX: 886-3-5825720

FCC ID : JCK-GN-WPMG
 Report No. : ER04-09-061FRF
 Page 22 of 58

The frequency spectrum above 1 GHz for Receiver was investigated. All emissions not reported are much lower than the prescribed limits. Readings are both peak and average values.

Company	GIGA-BYTE TECHNOLOGY CO., LTD.	Test Date	2004/12/03
Product Name	PCI Wireless LAN Card	Test By	Ken Tu
Model Name	GN-WPMG	TEMP & Humidity	22.3°C, 81%

CH11 RX				Measurement Distance at 1m Horizontal polarity							
Freq. (MHz)	Reading (dBμV)	AF (dBμV)	Cable (dB)	Pre-amp (dB)	Dist (dB)	Filter (dB)	Level (dBμV/m)	Limit (dBμV/m)	Margin (dB)	Mark (P/Q/A)	Height (Meter)
4175.99	44.82	32.49	4.88	34.90	9.50	0.00	37.79	74	-36.21	P	1.0
4175.99	33.41	32.49	4.88	34.90	9.50	0.00	26.38	54	-27.62	A	1.0
6264.02	44.62	37.63	6.45	34.30	9.50	0.00	44.90	74	-29.10	P	1.0
6264.02	33.34	37.63	6.45	34.30	9.50	0.00	33.62	54	-20.38	A	1.0
8351.99	45.17	39.25	7.53	34.42	9.50	0.00	48.02	74	-25.98	P	1.0
8351.99	34.03	39.25	7.53	34.42	9.50	0.00	36.88	54	-17.12	A	1.0

1. AF: Antenna Factor, Cable: Cable Loss, Pre-Amp: Preamplifier gain.
2. Spectrum analyzer setting P(Peak): RBW=1MHz, VBW=1MHz, A(Average): RBW=1MHz, VBW=10Hz
3. Dist : correction to extra plate reading to 3m specification distance 1m measurement distance = -9.5dB
4. The result basic equation calculation as follow :

$$\text{Level} = \text{Reading} + \text{AF} + \text{Cable} - \text{Preamp} + \text{Filter} - \text{Dist}, \text{Margin} = \text{Level} - \text{Limit}$$
5. The test limit is 3M limit.
6. The frequency was searched to 18GHz.
7. The other emission levels were very low against the limit.



Ecom Sertech Corp.

Rm. 258, Bldg. 17, NO.195, Sec.4 Chung Hsing Rd., ChuTugn Chen, Hsinchu, Taiwan 310, R.O.C
 TEL: 886-3-5918012 FAX: 886-3-5825720

FCC ID : JCK-GN-WPMG
 Report No. : ER04-09-061FRF
 Page 23 of 58

The frequency spectrum above 1 GHz for Receiver was investigated. All emissions not reported are much lower than the prescribed limits. Readings are both peak and average values.

Company	GIGA-BYTE TECHNOLOGY CO., LTD.	Test Date	2004/12/03
Product Name	PCI Wireless LAN Card	Test By	Ken Tu
Model Name	GN-WPMG	TEMP & Humidity	22.3°C, 81%

CH11 RX				Measurement Distance at 1m Vertical polarity							
Freq. (MHz)	Reading (dBμV)	AF (dBμV)	Cable (dB)	Pre-amp (dB)	Dist (dB)	Filter (dB)	Level (dBμV/m)	Limit (dBμV/m)	Margin (dB)	Mark (P/Q/A)	Height (Meter)
4175.98	44.46	32.49	4.88	34.90	9.50	0.00	37.43	74	-36.57	P	1.0
4175.98	33.84	32.49	4.88	34.90	9.50	0.00	26.81	54	-27.19	A	1.0
6264.03	44.52	37.63	6.45	34.30	9.50	0.00	44.80	74	-29.20	P	1.0
6264.03	33.50	37.63	6.45	34.30	9.50	0.00	33.78	54	-20.22	A	1.0
8351.97	44.93	39.25	7.53	34.43	9.50	0.00	47.78	74	-26.22	P	1.0
8351.97	34.67	39.25	7.53	34.43	9.50	0.00	37.52	54	-16.48	A	1.0

1. AF: Antenna Factor, Cable: Cable Loss, Pre-Amp: Preamplifier gain.
2. Spectrum analyzer setting P(Peak): RBW=1MHz, VBW=1MHz, A(Average): RBW=1MHz, VBW=10Hz
3. Dist : correction to extra plate reading to 3m specification distance 1m measurement distance = -9.5dB
4. The result basic equation calculation as follow :

$$\text{Level} = \text{Reading} + \text{AF} + \text{Cable} - \text{Preamp} + \text{Filter} - \text{Dist}, \text{Margin} = \text{Level} - \text{Limit}$$
5. The test limit is 3M limit.
6. The frequency was searched to 18GHz.
7. The other emission levels were very low against the limit.



Ecom Sertech Corp.

Rm. 258, Bldg. 17, NO.195, Sec.4 Chung Hsing Rd., ChuTugn Chen, Hsinchu, Taiwan 310, R.O.C
 TEL: 886-3-5918012 FAX: 886-3-5825720

FCC ID : JCK-GN-WPMG
 Report No. : ER04-09-061FRF
 Page 24 of 58

The frequency spectrum above 1 GHz for Transmitter was investigated. All emissions not reported are much lower than the prescribed limits. Readings are both peak and average values.

Company	GIGA-BYTE TECHNOLOGY CO., LTD.	Test Date	2004/12/10
Product Name	PCI Wireless LAN Card	Test By	Ken Tu
Model Name	GN-WPMG	TEMP & Humidity	25.6°C, 59%

CH1 TX				Measurement Distance at 1m Horizontal polarity							
Freq. (MHz)	Reading (dBμV)	AF (dBμV)	Cable (dB)	Pre-amp (dB)	Dist (dB)	Filter (dB)	Level (dBμV/m)	Limit (dBμV/m)	Margin (dB)	Mark (P/Q/A)	Height (Meter)
* 2389.90	28.30	31.81	3.57	0.00	9.50	0.00	54.18	74.00	-19.82	P	1.00
* 2389.90	17.30	31.81	3.57	0.00	9.50	0.00	43.18	54.00	-10.82	A	1.00
2413.40	85.21	31.79	3.58	0.00	9.50	0.00	111.08	Fundamental Frequency		P	1.00
2413.40	78.02	31.79	3.58	0.00	9.50	0.00	103.89			A	1.00
* 4824.30	46.14	34.44	5.08	35.16	9.50	2.00	43.01	74.00	-30.99	P	1.00
* 4824.30	34.90	34.44	5.08	35.16	9.50	2.00	31.77	54.00	-22.23	A	1.00
7236.00	43.89	39.81	6.74	35.65	9.50	2.00	47.28	91.08	-43.80	P	1.00
7236.00	33.40	39.81	6.74	35.65	9.50	2.00	36.79	83.89	-47.10	A	1.00
9648.00	44.50	38.54	8.29	36.44	9.50	0.61	46.00	91.08	-45.08	P	1.00
9648.00	34.18	38.54	8.29	36.44	9.50	0.61	35.68	83.89	-48.21	A	1.00
* 12067.00	-----	-----	-----	-----	9.50	0.80	-----	-----	-----	-----	1.00
* 14480.40	-----	-----	-----	-----	9.50	0.68	-----	-----	-----	-----	1.00
16893.80	-----	-----	-----	-----	9.50	0.44	-----	-----	-----	-----	1.00
* 19307.20	-----	-----	-----	-----	9.50	1.97	-----	-----	-----	-----	1.00
21720.60	-----	-----	-----	-----	9.50	0.81	-----	-----	-----	-----	1.00
24134.00	-----	-----	-----	-----	9.50	2.89	-----	-----	-----	-----	1.00

Note :

- The measurement was searched to 10th harmonic, Remark “---” means that the emissions level is too low to be measured.
- AF: Antenna Factor, Cable: Cable Loss, Pre-Amp: Preamplifier gain, Filter: High Pass Filter Insertion Loss (3.5GHz)
- Spectrum analyzer setting P(Peak): RBW=1MHz, VBW=1MHz, A(Average): RBW=1MHz, VBW=10Hz
- Remark “*” means the Restricted band.
- Dist : correction to extra plate reading to 3m specification distance 1m measurement distance = -9.5dB
- The result basic equation calculation is as follow:
 $Level = Reading + AF + Cable - Preamp + Filter - Dist$, $Margin = Level - Limit$
- The other emission levels were very low against the limit
- The test limit distance is 3M limit.
- For 802.11b mode at 11Mbps.



Ecom Sertech Corp.

Rm. 258, Bldg. 17, NO.195, Sec.4 Chung Hsing Rd., ChuTugn Chen, Hsinchu, Taiwan 310, R.O.C
 TEL: 886-3-5918012 FAX: 886-3-5825720

FCC ID : JCK-GN-WPMG
 Report No. : ER04-09-061FRF
 Page 25 of 58

The frequency spectrum above 1 GHz for Transmitter was investigated. All emissions not reported are much lower than the prescribed limits. Readings are both peak and average values.

Company	GIGA-BYTE TECHNOLOGY CO., LTD.	Test Date	2004/12/10
Product Name	PCI Wireless LAN Card	Test By	Ken Tu
Model Name	GN-WPMG	TEMP & Humidity	25.6°C, 59%

CH1 TX				Measurement Distance at 1m Vertical polarity							
Freq. (MHz)	Reading (dBμV)	AF (dBμV)	Cable (dB)	Pre-amp (dB)	Dist (dB)	Filter (dB)	Level (dBμV/m)	Limit (dBμV/m)	Margin (dB)	Mark (P/Q/A)	Height (Meter)
* 2389.90	39.10	31.81	3.57	0.00	9.50	0.00	64.98	74.00	-9.02	P	1.00
* 2389.90	27.50	31.81	3.57	0.00	9.50	0.00	53.38	54.00	-0.62	A	1.00
2413.20	94.96	31.79	3.58	0.00	9.50	0.00	120.83	Fundamental Frequency		P	1.00
2413.20	87.93	31.79	3.58	0.00	9.50	0.00	113.80			A	1.00
* 4824.07	51.66	34.44	5.08	35.16	9.50	2.00	48.53	74.00	-25.47	P	1.00
* 4824.07	39.69	34.44	5.08	35.16	9.50	2.00	36.56	54.00	-17.44	A	1.00
7238.21	44.92	39.80	6.74	35.65	9.50	2.00	48.31	100.83	-52.51	P	1.00
7238.21	33.44	39.80	6.74	35.65	9.50	2.00	36.83	93.80	-56.96	A	1.00
9648.00	44.35	38.54	8.29	36.44	9.50	0.61	45.85	100.83	-54.98	P	1.00
9648.00	34.29	38.54	8.29	36.44	9.50	0.61	35.79	93.80	-58.01	A	1.00
* 12066.00	-----	-----	-----	-----	9.50	0.80	-----	-----	-----	-----	1.00
* 14479.20	-----	-----	-----	-----	9.50	0.68	-----	-----	-----	-----	1.00
16892.40	-----	-----	-----	-----	9.50	0.44	-----	-----	-----	-----	1.00
* 19305.60	-----	-----	-----	-----	9.50	1.97	-----	-----	-----	-----	1.00
21718.80	-----	-----	-----	-----	9.50	0.81	-----	-----	-----	-----	1.00
24132.00	-----	-----	-----	-----	9.50	2.89	-----	-----	-----	-----	1.00

Note :

- The measurement was searched to 10th harmonic, Remark “---” means that the emissions level is too low to be measured.
- AF: Antenna Factor, Cable: Cable Loss, Pre-Amp: Preamplifier gain, Filter: High Pass Filter Insertion Loss (3.5GHz)
- Spectrum analyzer setting P(Peak): RBW=1MHz, VBW=1MHz, A(Average): RBW=1MHz, VBW=10Hz
- Remark “*” means the Restricted band.
- Dist : correction to extra plate reading to 3m specification distance 1m measurement distance = -9.5dB
- The result basic equation calculation is as follow:
 $Level = Reading + AF + Cable - Preamp + Filter - Dist$, $Margin = Level - Limit$
- The other emission levels were very low against the limit
- The test limit distance is 3M limit.
- For 802.11b mode at 11Mbps.
- The test data marked in gray background means the EUT emission data is located in the margin uncertainty range of emission limits.



Ecom Sertech Corp.

Rm. 258, Bldg. 17, NO.195, Sec.4 Chung Hsing Rd., ChuTugn Chen, Hsinchu, Taiwan 310, R.O.C
 TEL: 886-3-5918012 FAX: 886-3-5825720

FCC ID : JCK-GN-WPMG
 Report No. : ER04-09-061FRF
 Page 26 of 58

The frequency spectrum above 1 GHz for Transmitter was investigated. All emissions not reported are much lower than the prescribed limits. Readings are both peak and average values.

Company	GIGA-BYTE TECHNOLOGY CO., LTD.	Test Date	2004/12/10
Product Name	PCI Wireless LAN Card	Test By	Ken Tu
Model Name	GN-WPMG	TEMP & Humidity	25.6°C, 59%

CH6 TX				Measurement Distance at 1m Horizontal polarity							
Freq. (MHz)	Reading (dBμV)	AF (dBμV)	Cable (dB)	Pre-amp (dB)	Dist (dB)	Filter (dB)	Level (dBμV/m)	Limit (dBμV/m)	Margin (dB)	Mark (P/Q/A)	Height (Meter)
2438.45	84.75	31.76	3.59	0.00	9.50	0.00	110.60	Fundamental Frequency		P	1.00
2438.45	77.53	31.76	3.59	0.00	9.50	0.00	103.38			A	1.00
* 4868.18	44.35	34.73	5.10	35.19	9.50	1.83	41.31	74.00	-32.69	P	1.00
* 4868.18	32.02	34.73	5.10	35.19	9.50	1.83	28.98	54.00	-25.02	A	1.00
* 7314.55	44.47	39.77	6.79	35.64	9.50	2.00	47.90	74.00	-26.10	P	1.00
* 7314.55	32.88	39.77	6.79	35.64	9.50	2.00	36.31	54.00	-17.69	A	1.00
9798.98	45.26	38.52	8.35	36.68	9.50	0.52	46.47	90.60	-44.13	P	1.00
9798.98	33.20	38.52	8.35	36.68	9.50	0.52	34.41	83.38	-48.97	A	1.00
* 12192.25	-----	-----	-----	-----	9.50	0.80	-----	-----	-----	-----	1.00
14630.70	-----	-----	-----	-----	9.50	0.60	-----	-----	-----	-----	1.00
17069.15	-----	-----	-----	-----	9.50	0.53	-----	-----	-----	-----	1.00
* 19507.60	-----	-----	-----	-----	9.50	2.21	-----	-----	-----	-----	1.00
21946.05	-----	-----	-----	-----	9.50	0.72	-----	-----	-----	-----	1.00
24384.50	-----	-----	-----	-----	9.50	2.48	-----	-----	-----	-----	1.00

Note :

- The measurement was searched to 10th harmonic, Remark “---” means that the emissions level is too low to be measured.
- AF: Antenna Factor, Cable: Cable Loss, Pre-Amp: Preamplifier gain, Filter: High Pass Filter Insertion Loss (3.5GHz)
- Spectrum analyzer setting P(Peak): RBW=1MHz, VBW=1MHz, A(Average): RBW=1MHz, VBW=10Hz
- Remark “*” means the Restricted band.
- Dist : correction to extra plate reading to 3m specification distance 1m measurement distance = -9.5dB
- The result basic equation calculation is as follow:
 Level = Reading + AF + Cable - Preamp + Filter - Dist, Margin = Level - Limit
- The other emission levels were very low against the limit
- The test limit distance is 3M limit.
- For 802.11b mode at 11Mbps.



Ecom Sertech Corp.

Rm. 258, Bldg. 17, NO.195, Sec.4 Chung Hsing Rd., ChuTugn Chen, Hsinchu, Taiwan 310, R.O.C
 TEL: 886-3-5918012 FAX: 886-3-5825720

FCC ID : JCK-GN-WPMG
 Report No. : ER04-09-061FRF
 Page 27 of 58

The frequency spectrum above 1 GHz for Transmitter was investigated. All emissions not reported are much lower than the prescribed limits. Readings are both peak and average values.

Company	GIGA-BYTE TECHNOLOGY CO., LTD.	Test Date	2004/12/10
Product Name	PCI Wireless LAN Card	Test By	Ken Tu
Model Name	GN-WPMG	TEMP & Humidity	25.6°C, 59%

CH6 TX				Measurement Distance at 1m Vertical polarity							
Freq. (MHz)	Reading (dBμV)	AF (dBμV)	Cable (dB)	Pre-amp (dB)	Dist (dB)	Filter (dB)	Level (dBμV/m)	Limit (dBμV/m)	Margin (dB)	Mark (P/Q/A)	Height (Meter)
2438.25	94.72	31.76	3.59	0.00	9.50	0.00	120.57	Fundamental Frequency		P	1.00
2438.25	87.73	31.76	3.59	0.00	9.50	0.00	113.58			A	1.00
* 4873.43	51.45	34.76	5.10	35.20	9.50	1.81	48.42	74.00	-25.58	P	1.00
* 4873.43	39.84	34.76	5.10	35.20	9.50	1.81	36.81	54.00	-17.19	A	1.00
* 7314.64	44.58	39.77	6.79	35.64	9.50	2.00	48.01	74.00	-25.99	P	1.00
* 7314.64	32.61	39.77	6.79	35.64	9.50	2.00	36.04	54.00	-17.96	A	1.00
9746.16	45.16	38.53	8.33	36.59	9.50	0.55	46.47	100.57	-54.10	P	1.00
9746.16	32.80	38.53	8.33	36.59	9.50	0.55	34.11	93.58	-59.47	A	1.00
* 12191.25	-----	-----	-----	-----	9.50	0.80	-----	-----	-----	-----	1.00
14629.50	-----	-----	-----	-----	9.50	0.60	-----	-----	-----	-----	1.00
17067.75	-----	-----	-----	-----	9.50	0.53	-----	-----	-----	-----	1.00
* 19506.00	-----	-----	-----	-----	9.50	2.21	-----	-----	-----	-----	1.00
21944.25	-----	-----	-----	-----	9.50	0.72	-----	-----	-----	-----	1.00
24382.50	-----	-----	-----	-----	9.50	2.49	-----	-----	-----	-----	1.00

Note :

- The measurement was searched to 10th harmonic, Remark “---” means that the emissions level is too low to be measured.
- AF: Antenna Factor, Cable: Cable Loss, Pre-Amp: Preamplifier gain, Filter: High Pass Filter Insertion Loss (3.5GHz)
- Spectrum analyzer setting P(Peak): RBW=1MHz, VBW=1MHz, A(Average): RBW=1MHz, VBW=10Hz
- Remark “*” means the Restricted band.
- Dist : correction to extra plate reading to 3m specification distance 1m measurement distance = -9.5dB
- The result basic equation calculation is as follow:
 Level = Reading + AF + Cable - Preamp + Filter - Dist, Margin = Level - Limit
- The other emission levels were very low against the limit
- The test limit distance is 3M limit.
- For 802.11b mode at 11Mbps.



Ecom Sertech Corp.

Rm. 258, Bldg. 17, NO.195, Sec.4 Chung Hsing Rd., ChuTugn Chen, Hsinchu, Taiwan 310, R.O.C
 TEL: 886-3-5918012 FAX: 886-3-5825720

FCC ID : JCK-GN-WPMG
 Report No. : ER04-09-061FRF
 Page 28 of 58

The frequency spectrum above 1 GHz for Transmitter was investigated. All emissions not reported are much lower than the prescribed limits. Readings are both peak and average values.

Company	GIGA-BYTE TECHNOLOGY CO., LTD.	Test Date	2004/12/10
Product Name	PCI Wireless LAN Card	Test By	Ken Tu
Model Name	GN-WPMG	TEMP & Humidity	25.6°C, 59%

CH11 TX				Measurement Distance at 1m Horizontal polarity							
Freq. (MHz)	Reading (dBμV)	AF (dBμV)	Cable (dB)	Pre-amp (dB)	Dist (dB)	Filter (dB)	Level (dBμV/m)	Limit (dBμV/m)	Margin (dB)	Mark (P/Q/A)	Height (Meter)
2463.40	85.14	31.74	3.60	0.00	9.50	0.00	110.98	Fundamental Frequency		P	1.00
2463.40	78.00	31.74	3.60	0.00	9.50	0.00	103.84			A	1.00
* 2483.60	30.10	31.72	3.61	0.00	9.50	0.00	55.93	74.00	-18.07	P	1.00
* 2483.60	17.50	31.72	3.61	0.00	9.50	0.00	43.33	54.00	-10.67	A	1.00
* 4923.84	46.67	35.10	5.12	35.24	9.50	1.60	43.75	74.00	-30.25	P	1.00
* 4923.84	35.16	35.10	5.12	35.24	9.50	1.60	32.24	54.00	-21.76	A	1.00
* 7387.30	44.10	39.75	6.84	35.62	9.50	2.00	47.57	74.00	-26.43	P	1.00
* 7387.30	33.44	39.75	6.84	35.62	9.50	2.00	36.91	54.00	-17.09	A	1.00
9848.29	45.27	38.52	8.37	36.76	9.50	0.49	46.38	90.98	-44.60	P	1.00
9848.29	34.11	38.52	8.37	36.76	9.50	0.49	35.22	83.84	-48.62	A	1.00
* 12317.00	-----	-----	-----	-----	9.50	0.80	-----	-----	-----	-----	1.00
14780.40	-----	-----	-----	-----	9.50	0.48	-----	-----	-----	-----	1.00
17243.80	-----	-----	-----	-----	9.50	0.60	-----	-----	-----	-----	1.00
* 19707.20	-----	-----	-----	-----	9.50	2.41	-----	-----	-----	-----	1.00
* 22170.60	-----	-----	-----	-----	9.50	0.70	-----	-----	-----	-----	1.00
24634.00	-----	-----	-----	-----	9.50	2.11	-----	-----	-----	-----	1.00

- Note :
- The measurement was searched to 10th harmonic, Remark “---” means that the emissions level is too low to be measured.
 - AF: Antenna Factor, Cable: Cable Loss, Pre-Amp: Preamplifier gain, Filter: High Pass Filter Insertion Loss (3.5GHz)
 - Spectrum analyzer setting P(Peak): RBW=1MHz, VBW=1MHz, A(Average): RBW=1MHz, VBW=10Hz
 - Remark “*” means the Restricted band.
 - Dist : correction to extra plate reading to 3m specification distance 1m measurement distance = -9.5dB
 - The result basic equation calculation is as follow:
 Level = Reading + AF + Cable - Preamp + Filter - Dist, Margin = Level - Limit
 - The other emission levels were very low against the limit
 - The test limit distance is 3M limit.
 - For 802.11b mode at 11Mbps.



Ecom Sertech Corp.

Rm. 258, Bldg. 17, NO.195, Sec.4 Chung Hsing Rd., ChuTugn Chen, Hsinchu, Taiwan 310, R.O.C
 TEL: 886-3-5918012 FAX: 886-3-5825720

FCC ID : JCK-GN-WPMG
 Report No. : ER04-09-061FRF
 Page 29 of 58

The frequency spectrum above 1 GHz for Transmitter was investigated. All emissions not reported are much lower than the prescribed limits. Readings are both peak and average values.

Company	GIGA-BYTE TECHNOLOGY CO., LTD.	Test Date	2004/12/10
Product Name	PCI Wireless LAN Card	Test By	Ken Tu
Model Name	GN-WPMG	TEMP & Humidity	25.6°C, 59%

CH11 TX				Measurement Distance at 1m Vertical polarity							
Freq. (MHz)	Reading (dBμV)	AF (dBμV)	Cable (dB)	Pre-amp (dB)	Dist (dB)	Filter (dB)	Level (dBμV/m)	Limit (dBμV/m)	Margin (dB)	Mark (P/Q/A)	Height (Meter)
2463.45	94.44	31.74	3.60	0.00	9.50	0.00	120.28	Fundamental Frequency		P	1.00
2463.45	87.29	31.74	3.60	0.00	9.50	0.00	113.13			A	1.00
* 2483.60	38.20	31.72	3.61	0.00	9.50	0.00	64.03	74.00	-9.97	P	1.00
* 2483.60	26.30	31.72	3.61	0.00	9.50	0.00	52.13	54.00	-1.87	A	1.00
* 4923.90	51.73	35.10	5.12	35.24	9.50	1.60	48.81	74.00	-25.19	P	1.00
* 4923.90	40.27	35.10	5.12	35.24	9.50	1.60	37.35	54.00	-16.65	A	1.00
* 7393.12	45.82	39.74	6.85	35.62	9.50	2.00	49.29	74.00	-24.71	P	1.00
* 7393.12	33.63	39.74	6.85	35.62	9.50	2.00	37.10	54.00	-16.90	A	1.00
9845.64	45.42	38.52	8.36	36.75	9.50	0.49	46.54	100.28	-53.74	P	1.00
9845.64	34.07	38.52	8.36	36.75	9.50	0.49	35.19	93.13	-57.94	A	1.00
* 12317.25	-----	-----	-----	-----	9.50	0.80	-----	-----	-----	-----	1.00
14780.70	-----	-----	-----	-----	9.50	0.48	-----	-----	-----	-----	1.00
17244.15	-----	-----	-----	-----	9.50	0.60	-----	-----	-----	-----	1.00
* 19707.60	-----	-----	-----	-----	9.50	2.41	-----	-----	-----	-----	1.00
* 22171.05	-----	-----	-----	-----	9.50	0.70	-----	-----	-----	-----	1.00
24634.50	-----	-----	-----	-----	9.50	2.11	-----	-----	-----	-----	1.00

- Note :
- The measurement was searched to 10th harmonic, Remark “---” means that the emissions level is too low to be measured.
 - AF: Antenna Factor, Cable: Cable Loss, Pre-Amp: Preamplifier gain, Filter: High Pass Filter Insertion Loss (3.5GHz)
 - Spectrum analyzer setting P(Peak): RBW=1MHz, VBW=1MHz, A(Average): RBW=1MHz, VBW=10Hz
 - Remark “*” means the Restricted band.
 - Dist : correction to extra plate reading to 3m specification distance 1m measurement distance = -9.5dB
 - The result basic equation calculation is as follow:
 Level = Reading + AF + Cable - Preamp + Filter - Dist, Margin = Level - Limit
 - The other emission levels were very low against the limit
 - The test limit distance is 3M limit.
 - For 802.11b mode at 11Mbps.
 - The test data marked in gray background means the EUT emission data is located in the margin uncertainty range of emission limits.



Ecom Sertech Corp.

Rm. 258, Bldg. 17, NO.195, Sec.4 Chung Hsing Rd., ChuTugn Chen, Hsinchu, Taiwan 310, R.O.C
 TEL: 886-3-5918012 FAX: 886-3-5825720

FCC ID : JCK-GN-WPMG
 Report No. : ER04-09-061FRF
 Page 30 of 58

The frequency spectrum above 1 GHz for Transmitter was investigated. All emissions not reported are much lower than the prescribed limits. Readings are both peak and average values.

Company	GIGA-BYTE TECHNOLOGY CO., LTD.	Test Date	2004/12/10
Product Name	PCI Wireless LAN Card	Test By	Ken Tu
Model Name	GN-WPMG	TEMP & Humidity	25.6°C, 59%

CH1 TX				Measurement Distance at 1m Horizontal polarity							
Freq. (MHz)	Reading (dBμV)	AF (dBμV)	Cable (dB)	Pre-amp (dB)	Dist (dB)	Filter (dB)	Level (dBμV/m)	Limit (dBμV/m)	Margin (dB)	Mark (P/Q/A)	Height (Meter)
* 2389.90	33.80	31.81	3.57	0.00	9.50	0.00	59.68	74.00	-14.32	P	1.00
* 2389.90	17.40	31.81	3.57	0.00	9.50	0.00	43.28	54.00	-10.72	A	1.00
2413.70	79.24	31.79	3.58	0.00	9.50	0.00	105.11	Fundamental Frequency		P	1.00
2413.70	69.52	31.79	3.58	0.00	9.50	0.00	95.39			A	1.00
* 4832.28	44.27	34.49	5.09	35.17	9.50	1.97	41.15	74.00	-32.85	P	1.00
* 4832.28	32.68	34.49	5.09	35.17	9.50	1.97	29.56	54.00	-24.44	A	1.00
7235.89	44.54	39.81	6.74	35.65	9.50	2.00	47.93	85.11	-37.18	P	1.00
7235.89	33.43	39.81	6.74	35.65	9.50	2.00	36.82	75.39	-38.57	A	1.00
9646.49	46.40	38.54	8.29	36.43	9.50	0.61	47.91	85.11	-37.20	P	1.00
9646.49	34.00	38.54	8.29	36.43	9.50	0.61	35.51	75.39	-39.88	A	1.00
* 12068.50	-----	-----	-----	-----	9.50	0.80	-----	-----	-----	-----	1.00
* 14482.20	-----	-----	-----	-----	9.50	0.68	-----	-----	-----	-----	1.00
16895.90	-----	-----	-----	-----	9.50	0.44	-----	-----	-----	-----	1.00
* 19309.60	-----	-----	-----	-----	9.50	1.97	-----	-----	-----	-----	1.00
21723.30	-----	-----	-----	-----	9.50	0.81	-----	-----	-----	-----	1.00
24137.00	-----	-----	-----	-----	9.50	2.88	-----	-----	-----	-----	1.00

Note :

- The measurement was searched to 10th harmonic, Remark “---” means that the emissions level is too low to be measured.
- AF: Antenna Factor, Cable: Cable Loss, Pre-Amp: Preamplifier gain, Filter: High Pass Filter Insertion Loss (3.5GHz)
- Spectrum analyzer setting P(Peak): RBW=1MHz, VBW=1MHz, A(Average): RBW=1MHz, VBW=10Hz
- Remark “*” means the Restricted band.
- Dist : correction to extra plate reading to 3m specification distance 1m measurement distance = -9.5dB
- The result basic equation calculation is as follow:
 Level = Reading + AF + Cable - Preamp + Filter - Dist, Margin = Level - Limit
- The other emission levels were very low against the limit
- The test limit distance is 3M limit.
- For 802.11g mode at 54Mbps.



Ecom Sertech Corp.

Rm. 258, Bldg. 17, NO.195, Sec.4 Chung Hsing Rd., ChuTugn Chen, Hsinchu, Taiwan 310, R.O.C
 TEL: 886-3-5918012 FAX: 886-3-5825720

FCC ID : JCK-GN-WPMG
 Report No. : ER04-09-061FRF
 Page 31 of 58

The frequency spectrum above 1 GHz for Transmitter was investigated. All emissions not reported are much lower than the prescribed limits. Readings are both peak and average values.

Company	GIGA-BYTE TECHNOLOGY CO., LTD.	Test Date	2004/12/10
Product Name	PCI Wireless LAN Card	Test By	Ken Tu
Model Name	GN-WPMG	TEMP & Humidity	25.6°C, 59%

CH1 TX				Measurement Distance at 1m Vertical polarity							
Freq. (MHz)	Reading (dBμV)	AF (dBμV)	Cable (dB)	Pre-amp (dB)	Dist (dB)	Filter (dB)	Level (dBμV/m)	Limit (dBμV/m)	Margin (dB)	Mark (P/Q/A)	Height (Meter)
* 2389.90	42.50	31.81	3.57	0.00	9.50	0.00	68.38	74.00	-5.62	P	1.00
* 2389.90	26.40	31.81	3.57	0.00	9.50	0.00	52.28	54.00	-1.72	A	1.00
2413.75	89.92	31.79	3.58	0.00	9.50	0.00	115.79	Fundamental Frequency		P	1.00
2413.75	79.64	31.79	3.58	0.00	9.50	0.00	105.51			A	1.00
* 4816.65	45.02	34.39	5.08	35.15	9.50	2.03	41.87	74.00	-32.13	P	1.00
* 4816.65	33.30	34.39	5.08	35.15	9.50	2.03	30.15	54.00	-23.85	A	1.00
7236.03	43.27	39.81	6.74	35.65	9.50	2.00	46.66	95.79	-49.13	P	1.00
7236.03	32.98	39.81	6.74	35.65	9.50	2.00	36.37	85.51	-49.14	A	1.00
9648.90	45.52	38.54	8.29	36.44	9.50	0.61	47.02	95.79	-48.77	P	1.00
9648.90	34.28	38.54	8.29	36.44	9.50	0.61	35.78	85.51	-49.73	A	1.00
* 12068.75	-----	-----	-----	-----	9.50	0.80	-----	-----	-----	-----	1.00
* 14482.50	-----	-----	-----	-----	9.50	0.68	-----	-----	-----	-----	1.00
16896.25	-----	-----	-----	-----	9.50	0.44	-----	-----	-----	-----	1.00
* 19310.00	-----	-----	-----	-----	9.50	1.97	-----	-----	-----	-----	1.00
21723.75	-----	-----	-----	-----	9.50	0.81	-----	-----	-----	-----	1.00
24137.50	-----	-----	-----	-----	9.50	2.88	-----	-----	-----	-----	1.00

Note :

- The measurement was searched to 10th harmonic, Remark “---” means that the emissions level is too low to be measured.
- AF: Antenna Factor, Cable: Cable Loss, Pre-Amp: Preamplifier gain, Filter: High Pass Filter Insertion Loss (3.5GHz)
- Spectrum analyzer setting P(Peak): RBW=1MHz, VBW=1MHz, A(Average): RBW=1MHz, VBW=10Hz
- Remark “*” means the Restricted band.
- Dist : correction to extra plate reading to 3m specification distance 1m measurement distance = -9.5dB
- The result basic equation calculation is as follow:
 Level = Reading + AF + Cable - Preamp + Filter - Dist, Margin = Level - Limit
- The other emission levels were very low against the limit
- The test limit distance is 3M limit.
- For 802.11g mode at 54Mbps.
- The test data marked in gray background means the EUT emission data is located in the margin uncertainty range of emission limits.



Ecom Sertech Corp.

Rm. 258, Bldg. 17, NO.195, Sec.4 Chung Hsing Rd., ChuTugn Chen, Hsinchu, Taiwan 310, R.O.C
 TEL: 886-3-5918012 FAX: 886-3-5825720

FCC ID : JCK-GN-WPMG
 Report No. : ER04-09-061FRF
 Page 32 of 58

The frequency spectrum above 1 GHz for Transmitter was investigated. All emissions not reported are much lower than the prescribed limits. Readings are both peak and average values.

Company	GIGA-BYTE TECHNOLOGY CO., LTD.	Test Date	2004/12/10
Product Name	PCI Wireless LAN Card	Test By	Ken Tu
Model Name	GN-WPMG	TEMP & Humidity	25.6°C, 59%

CH6 TX				Measurement Distance at 1m Horizontal polarity							
Freq. (MHz)	Reading (dBμV)	AF (dBμV)	Cable (dB)	Pre-amp (dB)	Dist (dB)	Filter (dB)	Level (dBμV/m)	Limit (dBμV/m)	Margin (dB)	Mark (P/Q/A)	Height (Meter)
2438.75	79.09	31.76	3.59	0.00	9.50	0.00	104.94	Fundamental Frequency		P	1.00
2438.75	68.87	31.76	3.59	0.00	9.50	0.00	94.72			A	1.00
* 4866.82	44.27	34.72	5.10	35.19	9.50	1.83	41.23	74.00	-32.77	P	1.00
* 4866.82	32.57	34.72	5.10	35.19	9.50	1.83	29.53	54.00	-24.47	A	1.00
* 7261.10	44.85	39.80	6.76	35.65	9.50	2.00	48.26	74.00	-25.74	P	1.00
* 7261.10	32.97	39.80	6.76	35.65	9.50	2.00	36.38	54.00	-17.62	A	1.00
9812.70	45.46	38.52	8.35	36.70	9.50	0.51	46.64	84.94	-38.30	P	1.00
9812.70	32.93	38.52	8.35	36.70	9.50	0.51	34.11	74.72	-40.61	A	1.00
* 12193.75	-----	-----	-----	-----	9.50	0.80	-----	-----	-----	-----	1.00
14632.50	-----	-----	-----	-----	9.50	0.59	-----	-----	-----	-----	1.00
17071.25	-----	-----	-----	-----	9.50	0.53	-----	-----	-----	-----	1.00
* 19510.00	-----	-----	-----	-----	9.50	2.21	-----	-----	-----	-----	1.00
21948.75	-----	-----	-----	-----	9.50	0.72	-----	-----	-----	-----	1.00
24387.50	-----	-----	-----	-----	9.50	2.48	-----	-----	-----	-----	1.00

Note :

- The measurement was searched to 10th harmonic, Remark “---” means that the emissions level is too low to be measured.
- AF: Antenna Factor, Cable: Cable Loss, Pre-Amp: Preamplifier gain, Filter: High Pass Filter Insertion Loss (3.5GHz)
- Spectrum analyzer setting P(Peak): RBW=1MHz, VBW=1MHz, A(Average): RBW=1MHz, VBW=10Hz
- Remark “*” means the Restricted band.
- Dist : correction to extra plate reading to 3m specification distance 1m measurement distance = -9.5dB
- The result basic equation calculation is as follow:
 Level = Reading + AF + Cable - Preamp + Filter - Dist, Margin = Level - Limit
- The other emission levels were very low against the limit
- The test limit distance is 3M limit.
- For 802.11g mode at 54Mbps.



Ecom Sertech Corp.

Rm. 258, Bldg. 17, NO.195, Sec.4 Chung Hsing Rd., ChuTugn Chen, Hsinchu, Taiwan 310, R.O.C
 TEL: 886-3-5918012 FAX: 886-3-5825720

FCC ID : JCK-GN-WPMG
 Report No. : ER04-09-061FRF
 Page 33 of 58

The frequency spectrum above 1 GHz for Transmitter was investigated. All emissions not reported are much lower than the prescribed limits. Readings are both peak and average values.

Company	GIGA-BYTE TECHNOLOGY CO., LTD.	Test Date	2004/12/10
Product Name	PCI Wireless LAN Card	Test By	Ken Tu
Model Name	GN-WPMG	TEMP & Humidity	25.6°C, 59%

CH6 TX				Measurement Distance at 1m Vertical polarity							
Freq. (MHz)	Reading (dBμV)	AF (dBμV)	Cable (dB)	Pre-amp (dB)	Dist (dB)	Filter (dB)	Level (dBμV/m)	Limit (dBμV/m)	Margin (dB)	Mark (P/Q/A)	Height (Meter)
2438.75	89.46	31.76	3.59	0.00	9.50	0.00	115.31	Fundamental Frequency		P	1.00
2438.75	79.22	31.76	3.59	0.00	9.50	0.00	105.07			A	1.00
* 4875.50	44.54	34.78	5.10	35.20	9.50	1.80	41.52	74.00	-32.48	P	1.00
* 4875.50	33.43	34.78	5.10	35.20	9.50	1.80	30.41	54.00	-23.59	A	1.00
* 7316.21	44.17	39.77	6.80	35.64	9.50	2.00	47.60	74.00	-26.40	P	1.00
* 7316.21	32.75	39.77	6.80	35.64	9.50	2.00	36.18	54.00	-17.82	A	1.00
9752.80	45.17	38.52	8.33	36.60	9.50	0.55	46.47	95.31	-48.84	P	1.00
9752.80	32.75	38.52	8.33	36.60	9.50	0.55	34.05	85.07	-51.02	A	1.00
* 12193.75	-----	-----	-----	-----	9.50	0.80	-----	-----	-----	-----	1.00
14632.50	-----	-----	-----	-----	9.50	0.59	-----	-----	-----	-----	1.00
17071.25	-----	-----	-----	-----	9.50	0.53	-----	-----	-----	-----	1.00
* 19510.00	-----	-----	-----	-----	9.50	2.21	-----	-----	-----	-----	1.00
21948.75	-----	-----	-----	-----	9.50	0.72	-----	-----	-----	-----	1.00
24387.50	-----	-----	-----	-----	9.50	2.48	-----	-----	-----	-----	1.00

Note :

- The measurement was searched to 10th harmonic, Remark “---” means that the emissions level is too low to be measured.
- AF: Antenna Factor, Cable: Cable Loss, Pre-Amp: Preamplifier gain, Filter: High Pass Filter Insertion Loss (3.5GHz)
- Spectrum analyzer setting P(Peak): RBW=1MHz, VBW=1MHz, A(Average): RBW=1MHz, VBW=10Hz
- Remark “*” means the Restricted band.
- Dist : correction to extra plate reading to 3m specification distance 1m measurement distance = -9.5dB
- The result basic equation calculation is as follow:
 Level = Reading + AF + Cable - Preamp + Filter - Dist, Margin = Level - Limit
- The other emission levels were very low against the limit
- The test limit distance is 54M limit.
- For 802.11g mode at 54Mbps.



Ecom Sertech Corp.

Rm. 258, Bldg. 17, NO.195, Sec.4 Chung Hsing Rd., ChuTugn Chen, Hsinchu, Taiwan 310, R.O.C
 TEL: 886-3-5918012 FAX: 886-3-5825720

FCC ID : JCK-GN-WPMG
 Report No. : ER04-09-061FRF
 Page 34 of 58

The frequency spectrum above 1 GHz for Transmitter was investigated. All emissions not reported are much lower than the prescribed limits. Readings are both peak and average values.

Company	GIGA-BYTE TECHNOLOGY CO., LTD.	Test Date	2004/12/10
Product Name	PCI Wireless LAN Card	Test By	Ken Tu
Model Name	GN-WPMG	TEMP & Humidity	25.6°C, 59%

CH11 TX				Measurement Distance at 1m Horizontal polarity							
Freq. (MHz)	Reading (dBμV)	AF (dBμV)	Cable (dB)	Pre-amp (dB)	Dist (dB)	Filter (dB)	Level (dBμV/m)	Limit (dBμV/m)	Margin (dB)	Mark (P/Q/A)	Height (Meter)
2468.81	77.92	31.73	3.61	0.00	9.50	0.00	103.76	Fundamental Frequency		P	1.00
2468.81	69.10	31.73	3.61	0.00	9.50	0.00	94.94			A	1.00
* 2483.60	29.60	31.72	3.61	0.00	9.50	0.00	55.43	74.00	-18.57	P	1.00
* 2483.60	14.80	31.72	3.61	0.00	9.50	0.00	40.63	54.00	-13.37	A	1.00
* 4923.28	44.31	35.09	5.12	35.24	9.50	1.61	41.39	74.00	-32.61	P	1.00
* 4933.29	32.92	35.16	5.12	35.25	9.50	1.57	30.02	54.00	-23.98	A	1.00
* 7385.87	44.94	39.75	6.84	35.62	9.50	2.00	48.41	74.00	-25.59	P	1.00
* 7385.87	33.39	39.75	6.84	35.62	9.50	2.00	36.86	54.00	-17.14	A	1.00
9848.51	45.98	38.52	8.37	36.76	9.50	0.49	47.09	83.76	-36.66	P	1.00
9848.51	34.24	38.52	8.37	36.76	9.50	0.49	35.35	74.94	-39.58	A	1.00
* 12344.05	-----	-----	-----	-----	9.50	0.80	-----	-----	-----	-----	1.00
14812.86	-----	-----	-----	-----	9.50	0.45	-----	-----	-----	-----	1.00
17281.67	-----	-----	-----	-----	9.50	0.61	-----	-----	-----	-----	1.00
* 19750.48	-----	-----	-----	-----	9.50	2.45	-----	-----	-----	-----	1.00
* 22219.29	-----	-----	-----	-----	9.50	0.70	-----	-----	-----	-----	1.00
24688.10	-----	-----	-----	-----	9.50	2.04	-----	-----	-----	-----	1.00

Note :

- The measurement was searched to 10th harmonic, Remark “---” means that the emissions level is too low to be measured.
- AF: Antenna Factor, Cable: Cable Loss, Pre-Amp: Preamplifier gain, Filter: High Pass Filter Insertion Loss (3.5GHz)
- Spectrum analyzer setting P(Peak): RBW=1MHz, VBW=1MHz, A(Average): RBW=1MHz, VBW=10Hz
- Remark “*” means the Restricted band.
- Dist : correction to extra plate reading to 3m specification distance 1m measurement distance = -9.5dB
- The result basic equation calculation is as follow:
 Level = Reading + AF + Cable - Preamp + Filter - Dist, Margin = Level - Limit
- The other emission levels were very low against the limit
- The test limit distance is 3M limit.
- For 802.11g mode at 54Mbps.



Ecom Sertech Corp.

Rm. 258, Bldg. 17, NO.195, Sec.4 Chung Hsing Rd., ChuTugn Chen, Hsinchu, Taiwan 310, R.O.C
 TEL: 886-3-5918012 FAX: 886-3-5825720

FCC ID : JCK-GN-WPMG
 Report No. : ER04-09-061FRF
 Page 35 of 58

The frequency spectrum above 1 GHz for Transmitter was investigated. All emissions not reported are much lower than the prescribed limits. Readings are both peak and average values.

Company	GIGA-BYTE TECHNOLOGY CO., LTD.	Test Date	2004/12/10
Product Name	PCI Wireless LAN Card	Test By	Ken Tu
Model Name	GN-WPMG	TEMP & Humidity	25.6°C, 59%

CH11 TX				Measurement Distance at 1m Vertical polarity							
Freq. (MHz)	Reading (dBμV)	AF (dBμV)	Cable (dB)	Pre-amp (dB)	Dist (dB)	Filter (dB)	Level (dBμV/m)	Limit (dBμV/m)	Margin (dB)	Mark (P/Q/A)	Height (Meter)
2465.55	86.40	31.73	3.60	0.00	9.50	0.00	112.24	Fundamental Frequency		P	1.00
2465.55	76.89	31.73	3.60	0.00	9.50	0.00	102.73			A	1.00
* 2483.60	37.50	31.72	3.61	0.00	9.50	0.00	63.33	74.00	-10.67	P	1.00
* 2483.60	19.70	31.72	3.61	0.00	9.50	0.00	45.53	54.00	-8.47	A	1.00
* 4933.23	45.26	35.16	5.12	35.25	9.50	1.57	42.36	74.00	-31.64	P	1.00
* 4933.23	33.48	35.16	5.12	35.25	9.50	1.57	30.58	54.00	-23.42	A	1.00
* 7395.59	44.51	39.74	6.85	35.62	9.50	2.00	47.98	74.00	-26.02	P	1.00
* 7395.59	32.85	39.74	6.85	35.62	9.50	2.00	36.32	54.00	-17.68	A	1.00
9848.80	45.74	38.52	8.37	36.76	9.50	0.49	46.85	92.24	-45.39	P	1.00
9848.80	33.98	38.52	8.37	36.76	9.50	0.49	35.09	82.73	-47.64	A	1.00
* 12327.75	-----	-----	-----	-----	9.50	0.80	-----	-----	-----	-----	1.00
14793.30	-----	-----	-----	-----	9.50	0.47	-----	-----	-----	-----	1.00
17258.85	-----	-----	-----	-----	9.50	0.60	-----	-----	-----	-----	1.00
* 19724.40	-----	-----	-----	-----	9.50	2.42	-----	-----	-----	-----	1.00
* 22189.95	-----	-----	-----	-----	9.50	0.70	-----	-----	-----	-----	1.00
24655.50	-----	-----	-----	-----	9.50	2.08	-----	-----	-----	-----	1.00

Note :

- The measurement was searched to 10th harmonic, Remark “---” means that the emissions level is too low to be measured.
- AF: Antenna Factor, Cable: Cable Loss, Pre-Amp: Preamplifier gain, Filter: High Pass Filter Insertion Loss (3.5GHz)
- Spectrum analyzer setting P(Peak): RBW=1MHz, VBW=1MHz, A(Average): RBW=1MHz, VBW=10Hz
- Remark “*” means the Restricted band.
- Dist : correction to extra plate reading to 3m specification distance 1m measurement distance = -9.5dB
- The result basic equation calculation is as follow:
 Level = Reading + AF + Cable - Preamp + Filter - Dist, Margin = Level - Limit
- The other emission levels were very low against the limit
- The test limit distance is 3M limit.
- For 802.11g mode at 54Mbps.

3.7 Photos of Open Site





Ecom Sertech Corp.

Rm. 258, Bldg. 17, NO.195, Sec.4 Chung Hsing Rd., ChuTugn Chen, Hsinchu, Taiwan 310, R.O.C
TEL: 886-3-5918012 FAX: 886-3-5825720

FCC ID : JCK-GN-WPMG

Report No. : ER04-09-061FRF

Page 37 of 58

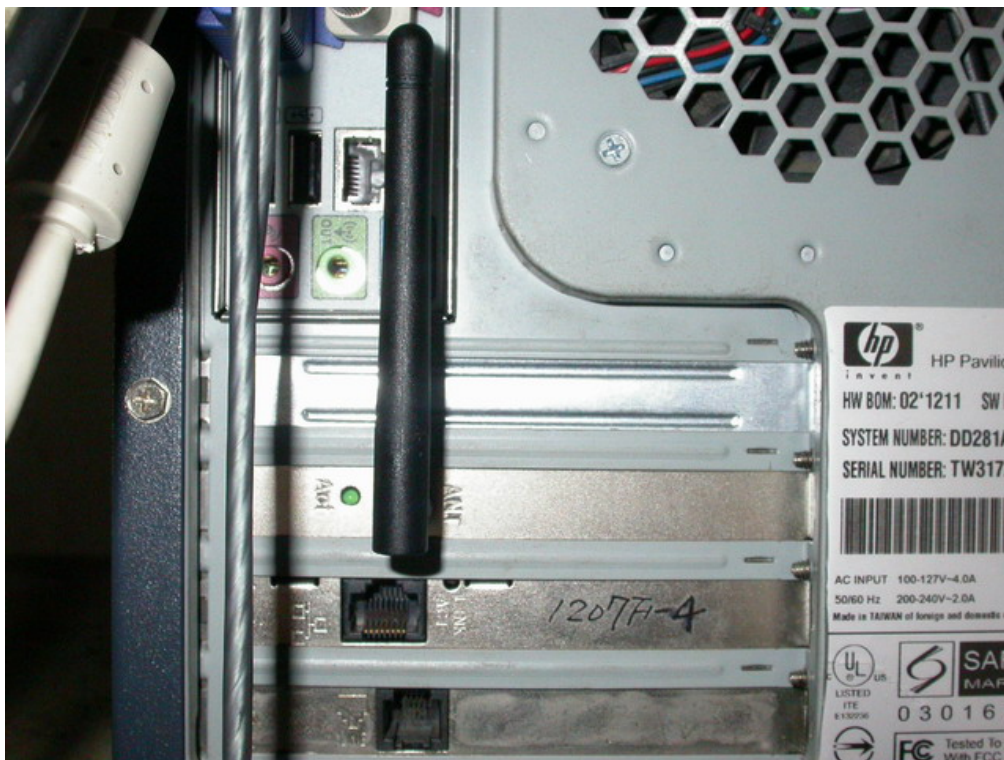



4. 6dB BANDWIDTH MEASUREMENT

4.1 Test Equipments

Description & Manufacturer	Model No.	Serial No.	Date Of Calibration	Calibration Period
ROHDE & SCHWARZ SPECTRUM ANALYZER	FSEK30	835253/002	September 06, 2004	1 Year

Note :

1. The measurement uncertainty is less than +/- 2.6dB, which is calculated as per the NAMAS document NIS81.
2. The calibration interval of the above test instruments is 12 months and the calibrations are traceable to NML/ROC and NIST/USA.

4.2 Test Setup



4.3 Limits of 6dB Bandwidth Measurement

The minimum of 6dB Bandwidth Measurement is >500KHz

4.4 Test Procedure

The transmitter output was connected to the spectrum analyzer through an attenuator. The bandwidth of the fundamental frequency was measured by spectrum analyzer with 100 KHz RBW and 1MHz VBW. The 6dB bandwidth is defined as the total spectrum the power of which is higher than peak power minus 6dB.

4.5 Uncertainty of Conducted Emission

The uncertainty of conducted emission is ± 200KHz.



Ecom Sertech Corp.

Rm. 258, Bldg. 17, NO.195, Sec.4 Chung Hsing Rd., ChuTugn Chen, Hsinchu, Taiwan 310, R.O.C
TEL: 886-3-5918012 FAX: 886-3-5825720

FCC ID : JCK-GN-WPMG

Report No. : ER04-09-061FRF

Page 39 of 58

4.6 Test Results

Company	GIGA-BYTE TECHNOLOGY CO., LTD.	Test Date	2004/12/16
Product Name	PCI Wireless LAN Card	Test By	Ken Tu
Model Name	GN-WPMG	TEMP & Humidity	23.2°C, 71%

Channel	Channel Frequency (MHz)	6dB Bandwidth (MHz)	Minimum Limit (MHz)	Pass / Fail
1	2412	10.22	0.5	PASS
6	2437	9.45	0.5	PASS
11	2462	9.85	0.5	PASS

Note : For 802.11b Mode

Channel	Channel Frequency (MHz)	6dB Bandwidth (MHz)	Minimum Limit (MHz)	Pass / Fail
1	2412	16.55	0.5	PASS
6	2437	16.63	0.5	PASS
11	2462	16.55	0.5	PASS

Note : For 802.11g Mode



4.7 Photo of 6db Bandwidth Measurement

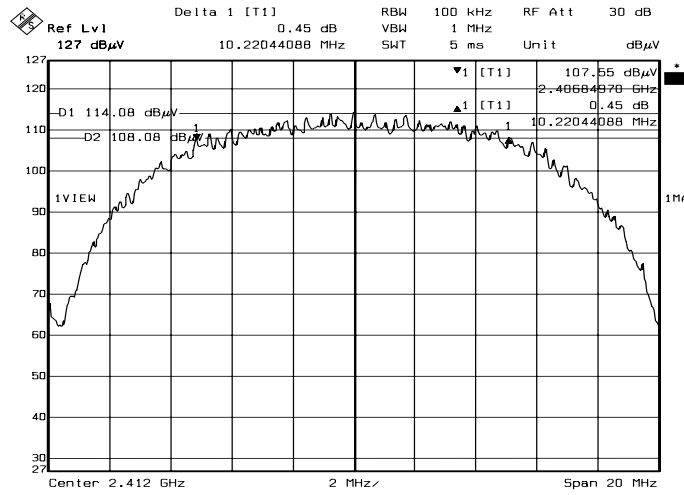

Date: 16.DEC.2004 18:33:08

Channel 1

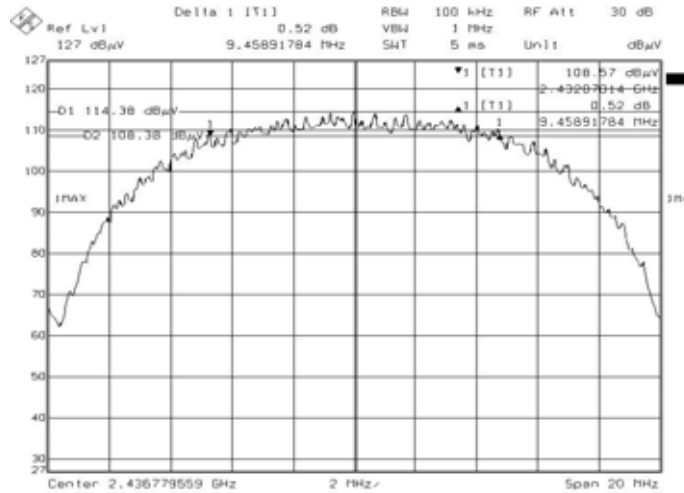

Date: 13.DEC.2004 12:20:18

Channel 6

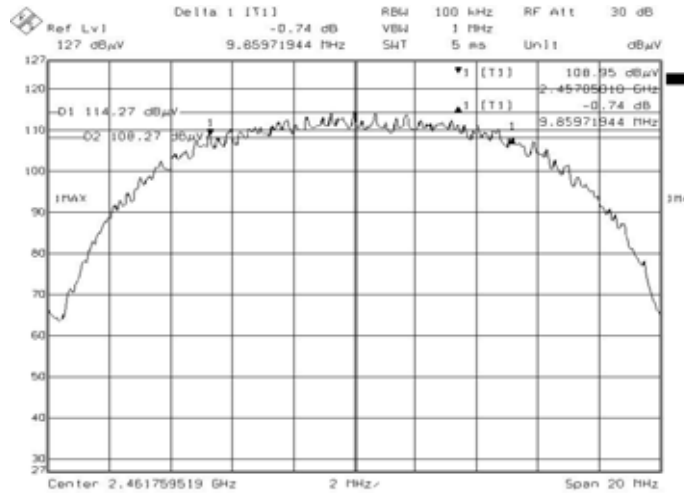

Date: 13.DEC.2004 12:25:17

Channel 11

Note: For 802.11b Mode

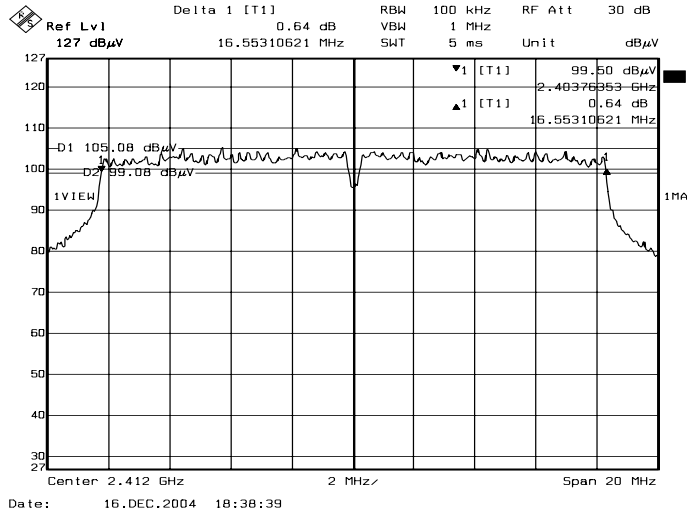

Channel 1

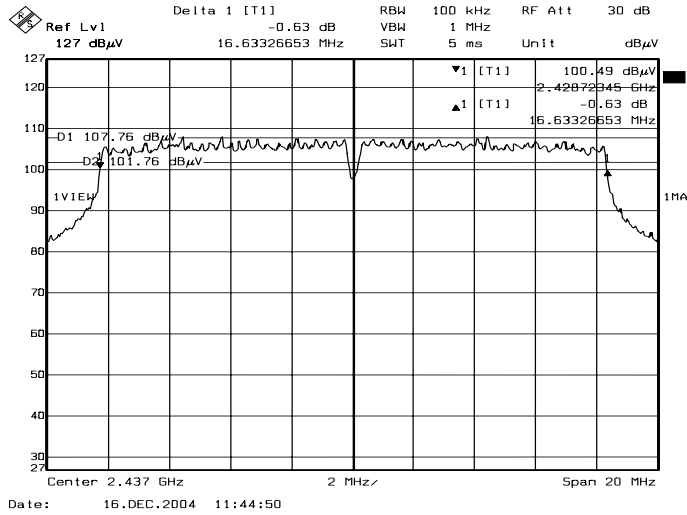

Channel 6

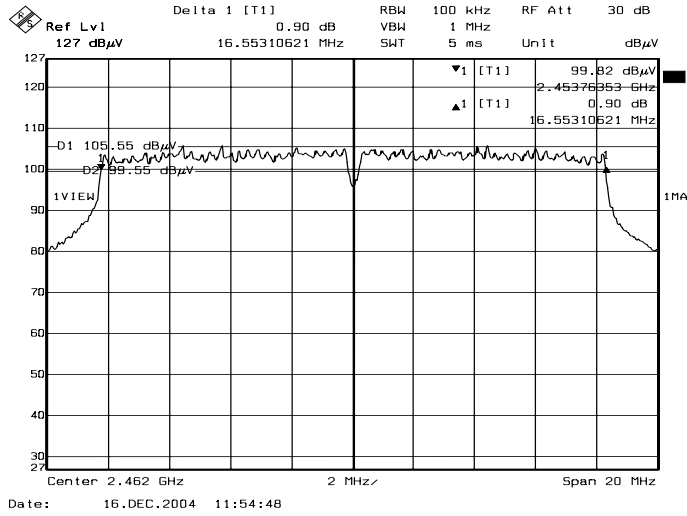

Channel 11

Note: For 802.11g Mode



5. MAXIMUM PEAK OUTPUT POWER

5.1 Test Equipments

Description & Manufacturer	Model No.	Serial No.	Date Of Calibration	Calibration Period
ROHDE & SCHWARZ SPECTRUM ANALYZER	FSEK30	835253/002	September 06, 2004	1 Year
ANRITSU Peak Power Meter	ML2487A MAL2491A	6K00001783 030982	February 10, 2004	1 Year

Note :

1. The measurement uncertainty is less than +/- 2.6dB, which is calculated as per the NAMAS document NIS81.
2. The calibration interval of the above test instruments is 12 months and the calibrations are traceable to NML/ROC and NIST/USA.

5.2 Test Setup

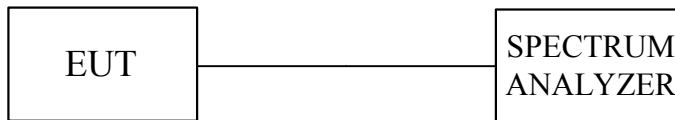

5.3 Limits of Maximum Peak Output Power

The Maximum Peak Output Power Measurement is 30dBm.

5.4 Test Procedure

1. The spectrum shall be set as follows :
Span : 1.5 times channel integration bandwidth.
RBW : 1MHz
VBW : 3MHz
Detector : Peak
Sweep : Single trace
2. Compute the combined power of all signal responses contained in the trace by covering all the data points.
3. For 99% occupied BW, place the markers at the frequency at which 0.5% of the power lies to the right of the right marker and 0.5% of the power lies to the left of the left marker.
4. The peak output power is the channel power integrated over 99% bandwidth.



5.5 Uncertainty of Conducted Emission

The uncertainty of conducted emission is $\pm 1.82\text{dB}$.

5.6 Test Results

Company	GIGA-BYTE TECHNOLOGY CO., LTD.	Test Date	2004/12/16
Product Name	PCI Wireless LAN Card	Test By	Ken Tu
Model Name	GN-WPMG	TEMP & Humidity	23.2°C, 71%

Channel	Channel Frequency (MHz)	Peak Power Output (dBm)	Peak Power Limit (dBm)	Pass / Fail
1	2412	21.40	30	PASS
6	2437	21.34	30	PASS
11	2462	21.79	30	PASS

Note :

1. For 802.11b mode.
2. At final test to get the worst-case emission at 11Mbps.
3. Cable loss = 1.55dB, Attenuator = 10dB.
4. The results are calculated as the following equation :
Peak Power Output = Peak Power Reading + Cable loss

Channel	Channel Frequency (MHz)	Peak Power Output (dBm)	Peak Power Limit (dBm)	Pass / Fail
1	2412	17.23	30	PASS
6	2437	17.67	30	PASS
11	2462	17.32	30	PASS

Note :

1. For 802.11g mode.
2. At final test to get the worst-case emission at 54Mbps.
3. Cable loss = 1.55dB, Attenuator = 10dB.
4. The results are calculated as the following equation :
Peak Power Output = Peak Power Reading + Cable loss

5.7 Photo of Maximum Peak Output Power Measurement



Ecom Sertech Corp.

Rm. 258, Bldg. 17, NO.195, Sec.4 Chung Hsing Rd., ChuTugn Chen, Hsinchu, Taiwan 310, R.O.C
TEL: 886-3-5918012 FAX: 886-3-5825720

FCC ID : JCK-GN-WPMG

Report No. : ER04-09-061FRF

Page 44 of 58

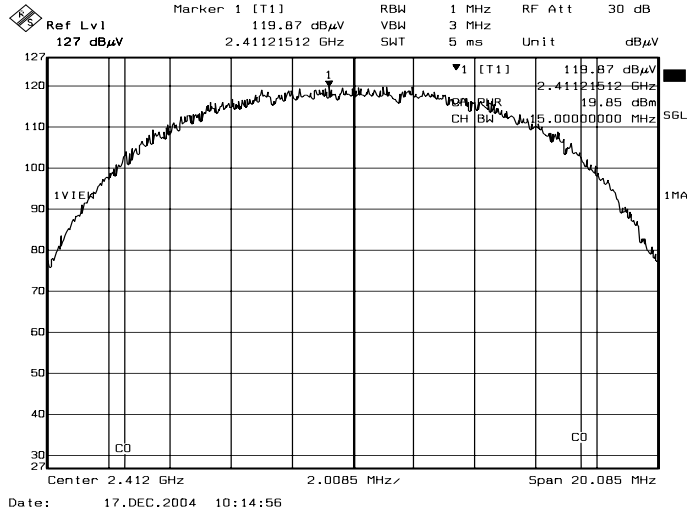

Date: 17.DEC.2004 10:14:56

Channel 1

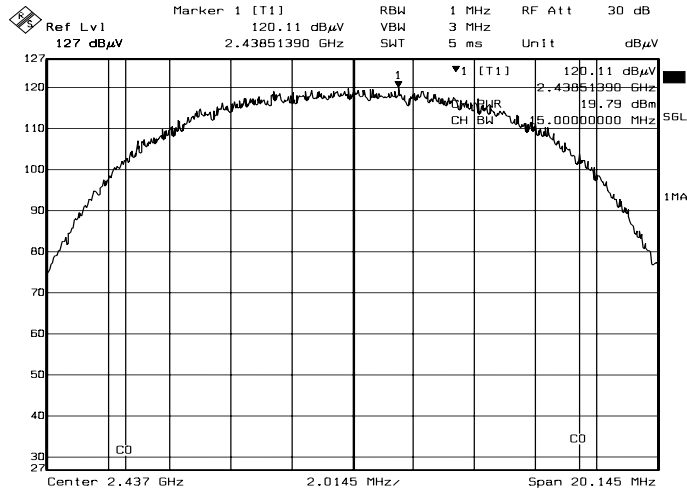

Date: 17.DEC.2004 10:24:06

Channel 6

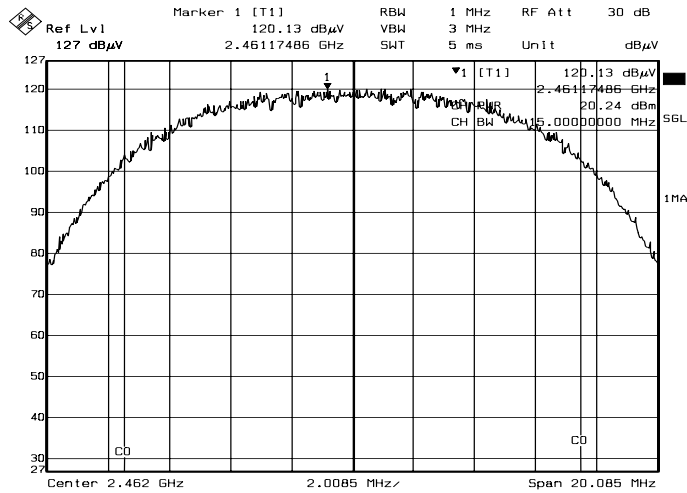

Date: 17.DEC.2004 10:27:22

Channel 11

Note: For 802.11b Mode



Ecom Sertech Corp.

Rm. 258, Bldg. 17, NO.195, Sec.4 Chung Hsing Rd., ChuTugn Chen, Hsinchu, Taiwan 310, R.O.C
TEL: 886-3-5918012 FAX: 886-3-5825720

FCC ID : JCK-GN-WPMG

Report No. : ER04-09-061FRF

Page 45 of 58

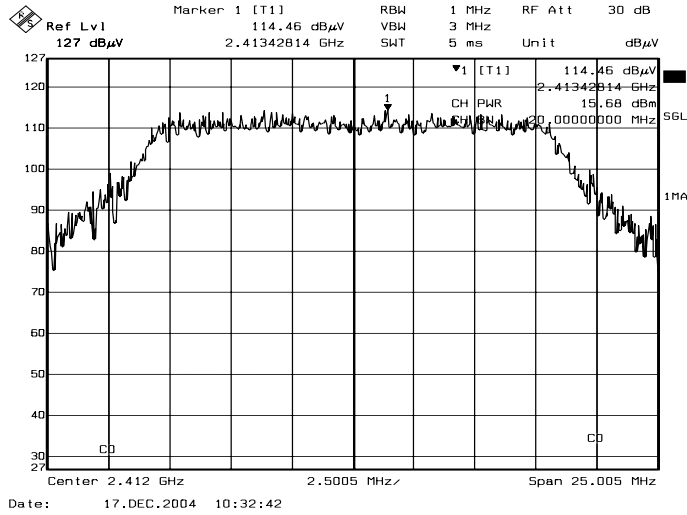

Channel 1

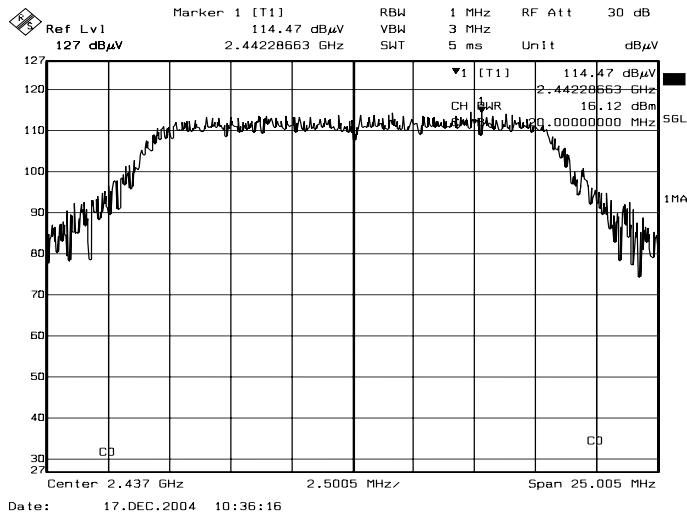

Channel 6

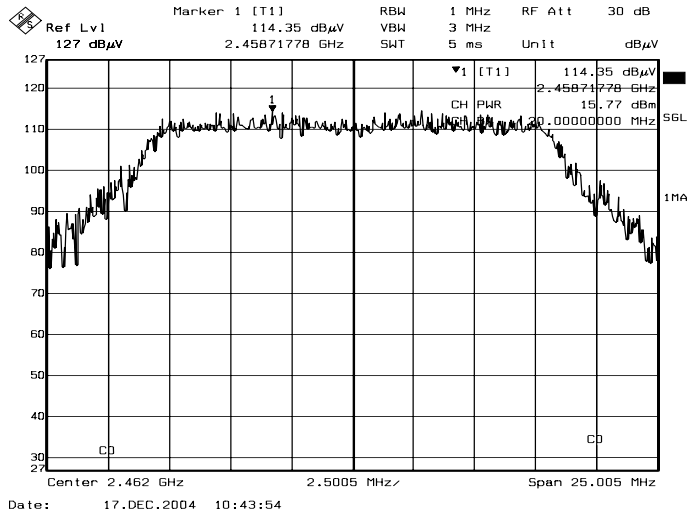

Channel 11

Note: For 802.11g Mode



6. POWER SPECTRAL DENSITY MEASUREMENT

6.1 Test Equipments

Description & Manufacturer	Model No.	Serial No.	Date Of Calibration	Calibration Period
ROHDE & SCHWARZ SPECTRUM ANALYZER	FSEK30	835253/002	September 06, 2004	1 Year

Note :

1. The measurement uncertainty is less than +/- 2.6dB, which is calculated as per the NAMAS document NIS81.
2. The calibration interval of the above test instruments is 12 months and the calibrations are traceable to NML/ROC and NIST/USA.

6.2 Test Setup

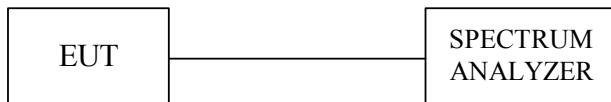

6.3 Limits of Power Spectral Density Measurement

The Maximum Power Spectral Density Measurement is 8dBm/3KHz.



6.4 Test Procedure

The transmitter output was connected to the spectrum analyzer through an attenuator, the bandwidth of the fundamental frequency was measured with the spectrum analyzer using 3KHz RBW and 30KHz VBW, set sweep time=span / 3KHz.

The power spectral density was measured and recorded.

The sweep time is allowed to be longer than span / 3KHz for a full response of the mixer in the spectrum analyzer.

6.5 Uncertainty of Conducted Emission

The uncertainty of conducted emission is $\pm 1.82\text{dB}$.

6.6 Test Results

Company	GIGA-BYTE TECHNOLOGY CO., LTD.	Test Date	2004/12/16
Product Name	PCI Wireless LAN Card	Test By	Ken Tu
Model Name	GN-WPMG	TEMP & Humidity	23.2°C, 71%

Channel	Channel Frequency (MHz)	Final RF Power Level in 3KHz BW (dBm)	Maxmum Limit (dBm)	Pass / Fail
1	2412	-7.46	8	PASS
6	2437	-7.39	8	PASS
11	2462	-7.16	8	PASS

Note : For 11Mbps (802.11b mode) at finial test to get the worst-case emission at 11Mbps.

Channel	Channel Frequency (MHz)	Final RF Power Level in 3KHz BW (dBm)	Maxmum Limit (dBm)	Pass / Fail
1	2412	-19.36	8	PASS
6	2437	-16.68	8	PASS
11	2462	-16.55	8	PASS

Note : For 54Mbps (802.11g mode) at finial test to get the worst-case emission at 54Mbps.



6.7 Photo of Power Spectral Density Measurement

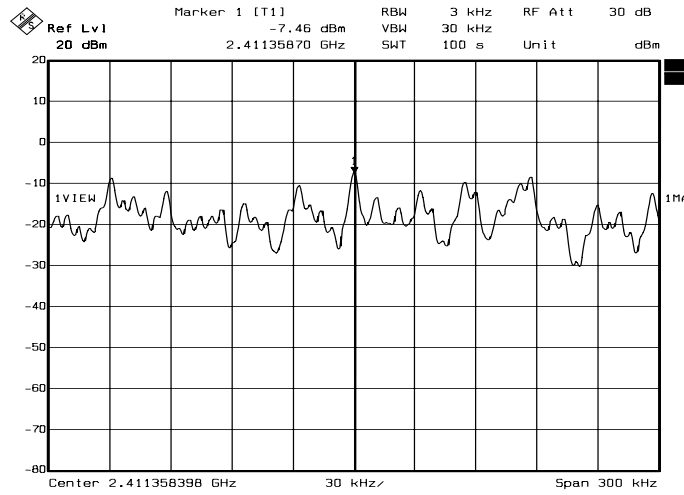

Channel 1

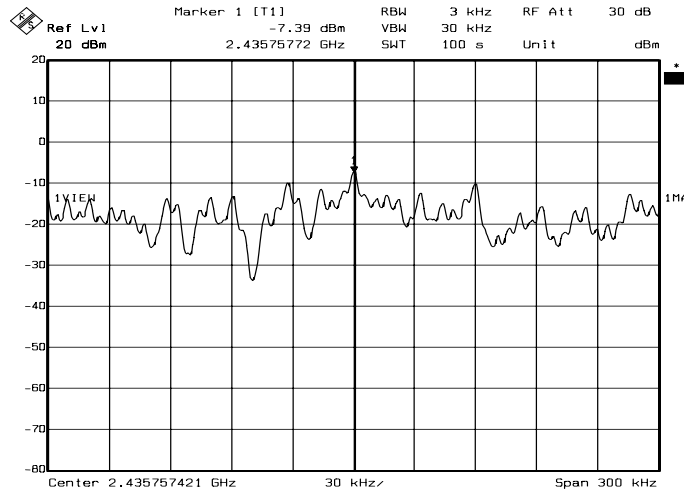

Channel 6

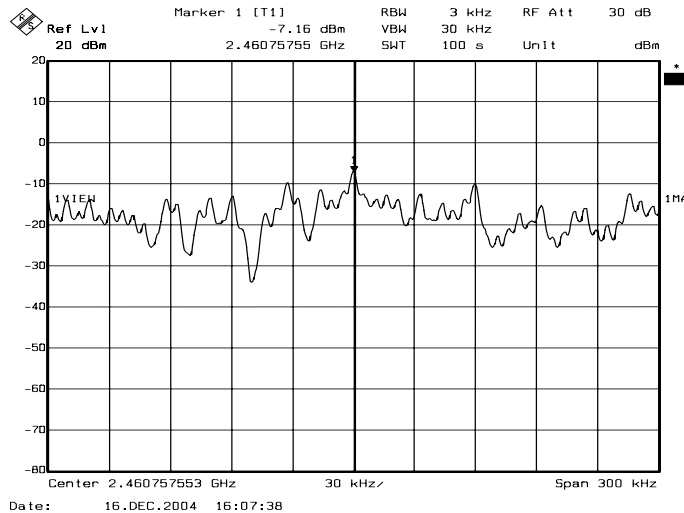

Channel 11

Note: For 802.11b Mode



Ecom Sertech Corp.

Rm. 258, Bldg. 17, NO.195, Sec.4 Chung Hsing Rd., ChuTugn Chen, Hsinchu, Taiwan 310, R.O.C
TEL: 886-3-5918012 FAX: 886-3-5825720

FCC ID : JCK-GN-WPMG

Report No. : ER04-09-061FRF

Page 49 of 58

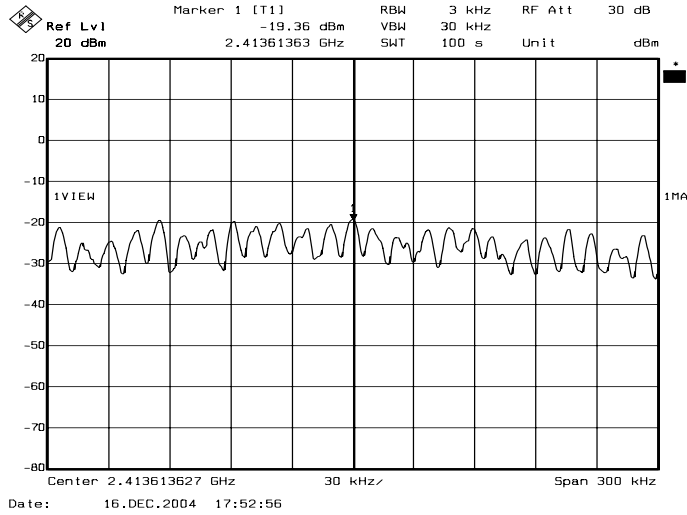

Channel 1

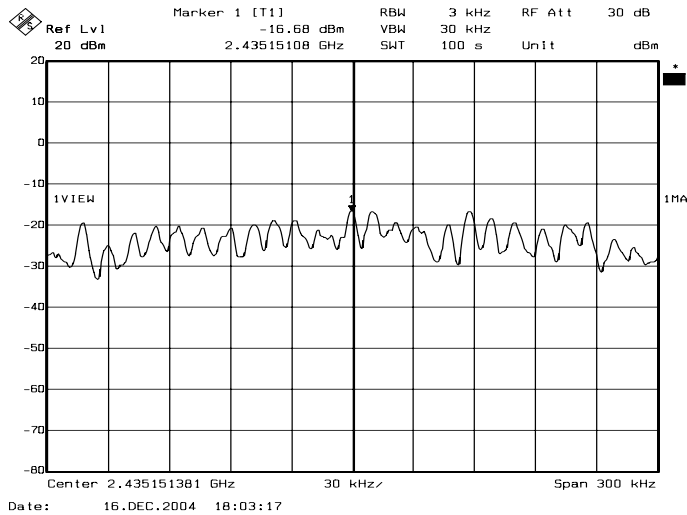

Channel 6

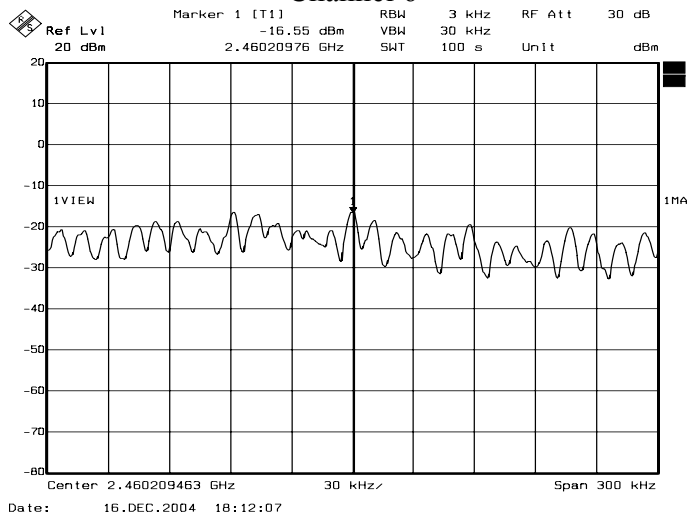

Channel 11

Note: For 802.11g Mode

7. BAND EDGE MEASUREMENT

7.1 Test Equipments

Description & Manufacturer	Model No.	Serial No.	Date Of Calibration	Calibration Period
ROHDE & SCHWARZ SPECTRUM ANALYZER	FSEK30	835253/002	September 06, 2004	1 Year

Note :

1. The measurement uncertainty is less than +/- 2.6dB, which is calculated as per the NAMAS document NIS81.
2. The calibration interval of the above test instruments is 12 months and the calibrations are traceable to NML/ROC and NIST/USA.

7.2 Test Setup

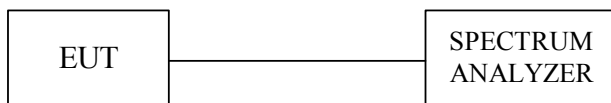

7.3 Limits of Band Edge Emissions Measurement

1. Below -20dB of the highest emission level in operating band.
2. Fall in the restricted bands listed in section 15.205. The maximum permitted average field strength is listed in section 15.209.

7.4 Test Procedure

The band edge compliance of RF radiated emission should be measured by following the guidance in ANSI C63.4 with respect to maximizing the emission by rotating the EUT , measuring the emission while the EUT is situated in three orthogonal planes (if appropriate), adjusting the measurement antenna height and polarization etc. Set RBW and VBM to 1MHz to measure the peak field strength and set RBW to 1MHz and VBW to 10Hz to measure the average radiated field strength.

The spurious RF conducted emissions was measured by using a spectrum analyzer. Set span wide enough to capture the peak level of the in-band emission and all spurious emissions from 30MHz to 10th harmonic, set RBW and VBW to 100kHz, set trace max hold and allow the trace to stabilize. Several plots are plotted to cover the entire span.

7.5 Uncertainty of Conducted Emission

The uncertainty of conducted emission is ± 1.82dB.



7.6 Test Results

A. Conducted

Refer to 7.7 photo of out band Emission measurement

B. Radiated

Company	GIGA-BYTE TECHNOLOGY CO., LTD.	Test Date	2004/12/10
Product Name	PCI Wireless LAN Card	Test By	Ken Tu
Model Name	GN-WPMG	TEMP & Humidity	25.6°C, 59%

For 802.11b mode

Refer to the section 3.6, the measured radiated band edge emissions are listed below :

Band edge Frequency (MHz)		Measured radiated band edge field strength (dBuV/m)		Radiated band edge field strength limit (dBuV/m)		Test result
		Horizontal	Vertical	Horizontal	Vertical	
2399.90	PK	59.28	70.38	91.08	100.83	PASS
	AV	49.28	58.08	83.89	93.80	
2483.50	PK	54.93	64.43	74.00	74.00	PASS
	AV	43.23	52.23	54.00	54.00	

For 802.11g mode

Refer to the section 3.6, the measured radiated band edge emissions are listed below :

Band edge Frequency (MHz)		Measured radiated band edge field strength (dBuV/m)		Radiated band edge field strength limit (dBuV/m)		Test result
		Horizontal	Vertical	Horizontal	Vertical	
2399.90	PK	73.48	83.78	85.11	95.79	PASS
	AV	57.68	67.48	75.39	85.51	
2483.50	PK	55.93	63.63	74.00	74.00	PASS
	AV	40.83	45.63	54.00	54.00	

Note : Radiated band edge field strength is measured according to measurement procedure ANSI C63.4-2003.



7.7 Photo of Band edge Measurement

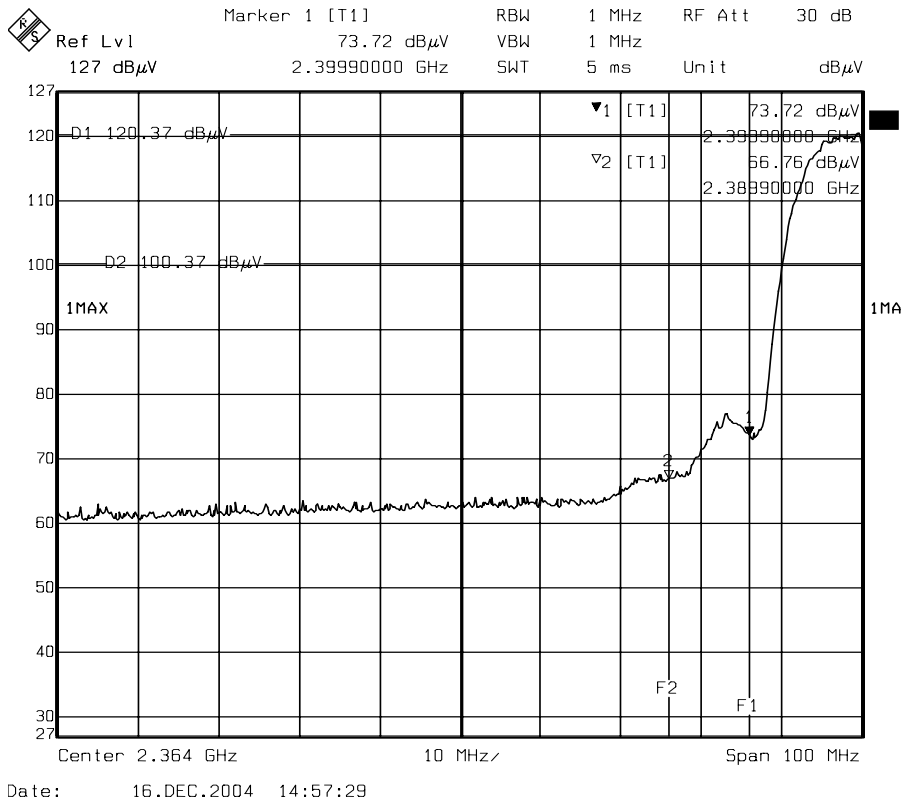

Lower Band edge (Peak)

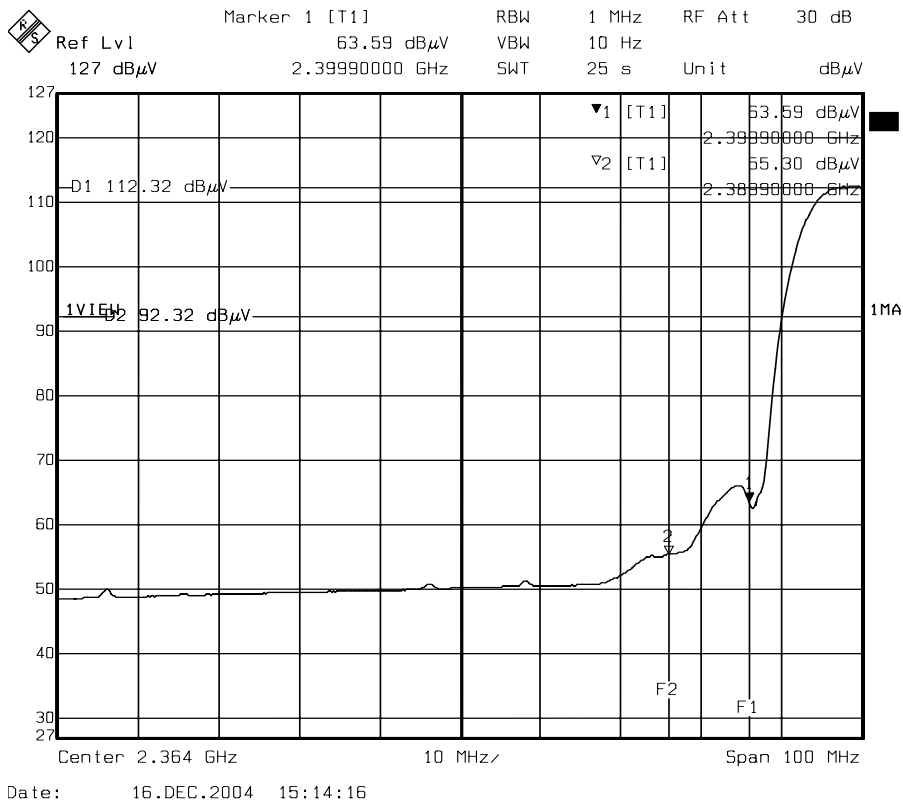

Lower Band edge (Average)

Note: For 802.11b Mode



Ecom Sertech Corp.

Rm. 258, Bldg. 17, NO.195, Sec.4 Chung Hsing Rd., ChuTugn Chen, Hsinchu, Taiwan 310, R.O.C
TEL: 886-3-5918012 FAX: 886-3-5825720

FCC ID : JCK-GN-WPMG

Report No. : ER04-09-061FRF

Page 53 of 58

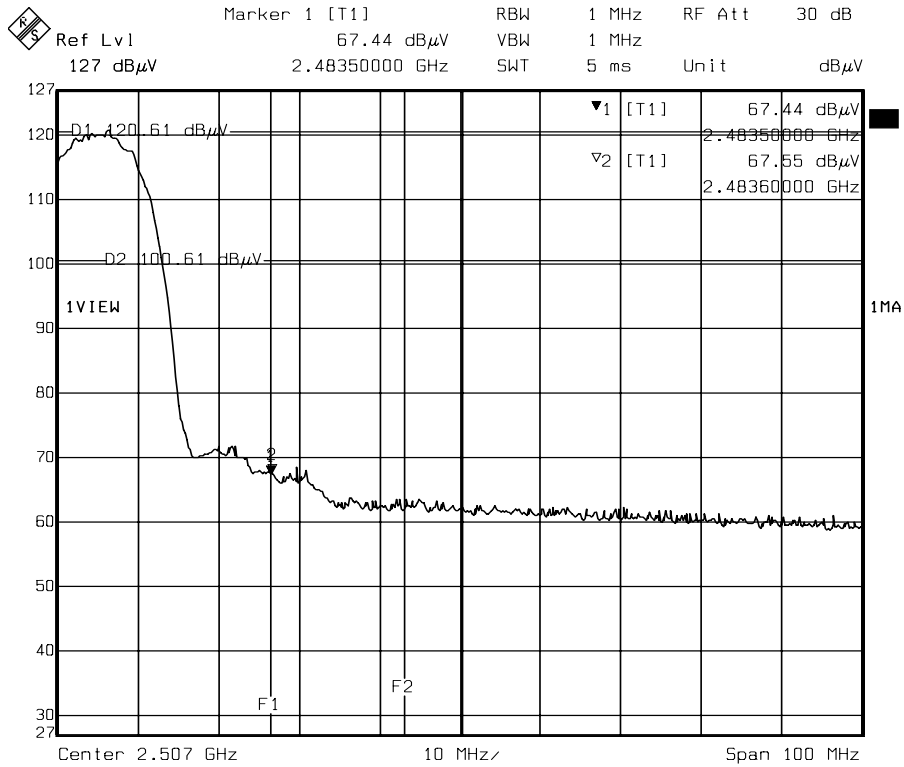

Date: 16.DEC.2004 15:23:20

Higher Band edge (Peak)

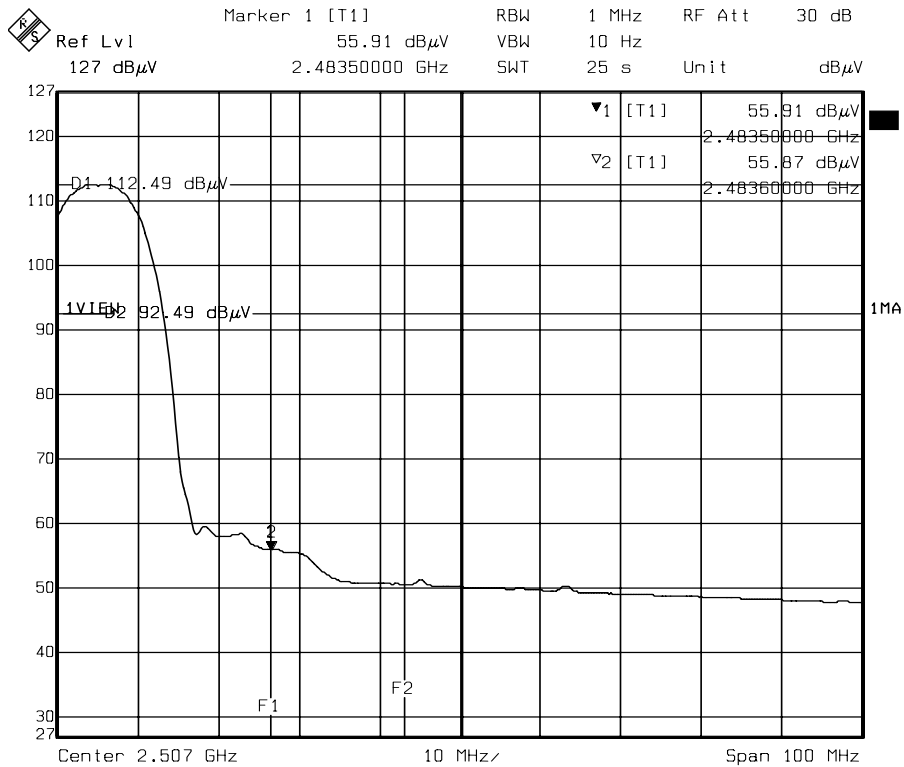

Date: 16.DEC.2004 15:29:01

Higher Band edge (Average)

Note: For 802.11b Mode



Ecom Sertech Corp.

Rm. 258, Bldg. 17, NO.195, Sec.4 Chung Hsing Rd., ChuTugn Chen, Hsinchu, Taiwan 310, R.O.C
TEL: 886-3-5918012 FAX: 886-3-5825720

FCC ID : JCK-GN-WPMG

Report No. : ER04-09-061FRF

Page 54 of 58

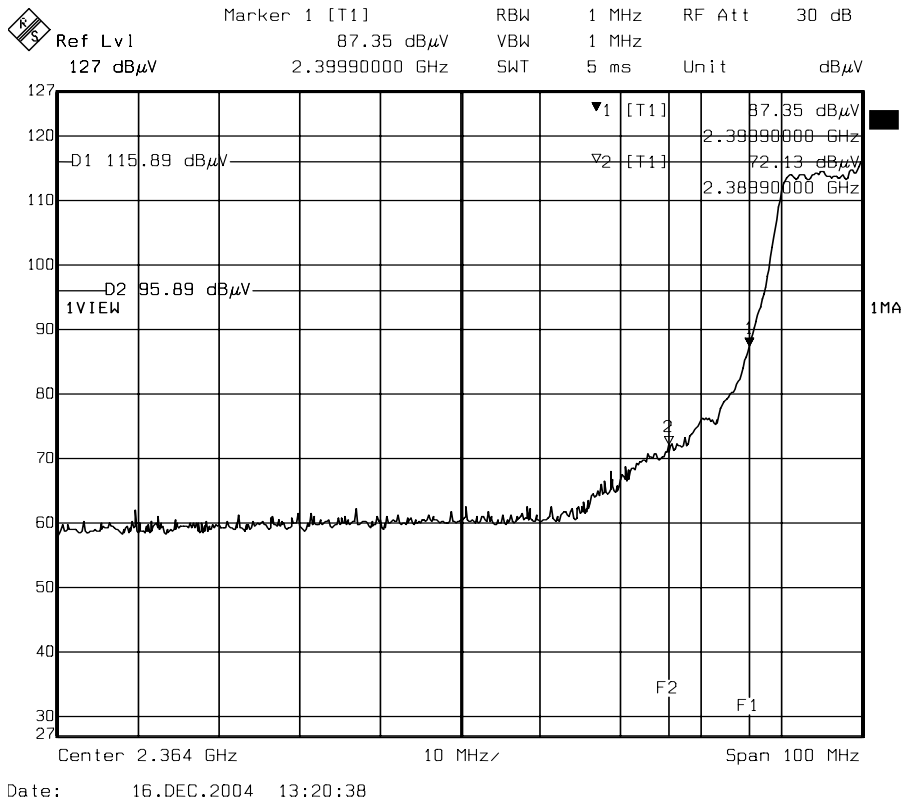

Lower Band edge (Peak)

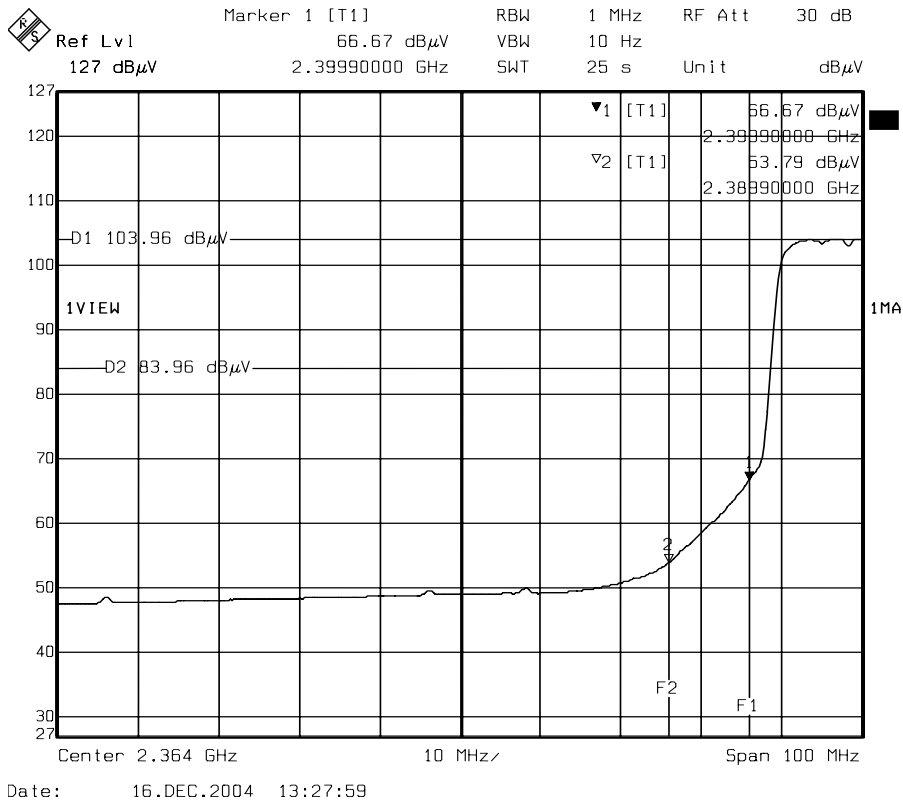

Lower Band edge (Average)

Note: For 802.11g Mode



Ecom Sertech Corp.

Rm. 258, Bldg. 17, NO.195, Sec.4 Chung Hsing Rd., ChuTugn Chen, Hsinchu, Taiwan 310, R.O.C
TEL: 886-3-5918012 FAX: 886-3-5825720

FCC ID : JCK-GN-WPMG

Report No. : ER04-09-061FRF

Page 55 of 58

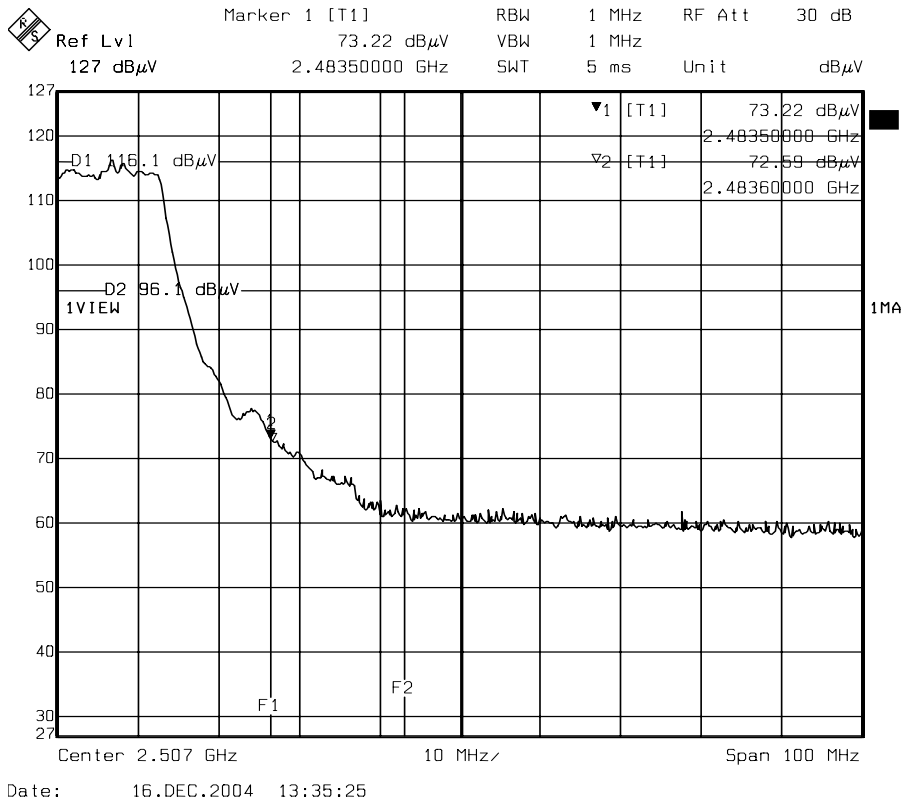

Higher Band edge (Peak)

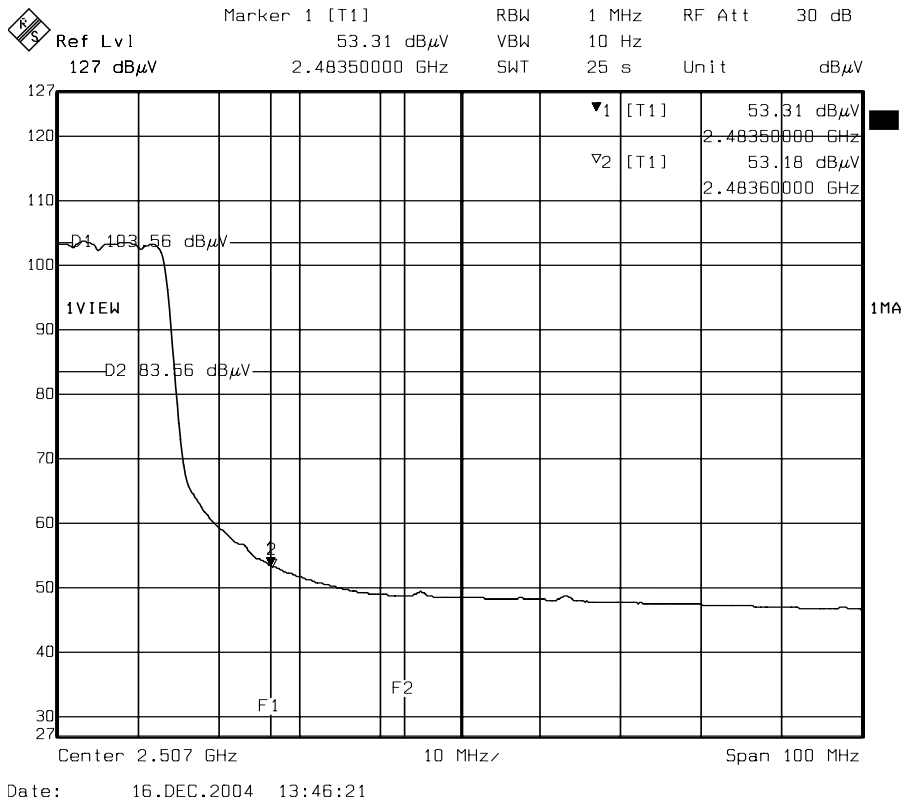

Higher Band edge (Average)

Note: For 802.11g Mode



8. ANTENNA REQUIREMENT

8.1 Standard Applicable

For intentional device, according to FCC 47 CFR Section 15.203, an intentional radiator shall be designed to ensure that no antenna other than that furnished by the responsible party shall be used with the device.

And according to FCC 47 CFR Section 15.247 (c), if transmitting antennas of directional gain greater than 6dBi are used, the power shall be reduced by the amount in dB that the directional gain of the antenna exceeds 6dBi.

8.2 Antenna Connected Construction

The antenna used in this product is Dipole antenna. The maximum Gain of this antenna is only 1.8dBi.



9. RF EXPOSURE EVALUATION

According to FCC 1.1310 : The criteria listed in the following table shall be used to evaluate the environment impact of human exposure to radio frequency (RF) radiation as specified in 1.1307(b)

LIMITS FOR MAXIMUM PERMISSIBLE EXPOSURE (MPE)

Frequency Range (MHz)	Electric Field Strength (V/m)	Magnetic Field Strength (A/m)	Power Density (mW/cm ²)	Average Time
(A) Limits for Occupational / Control Exposures				
300-1,500	--	--	F/300	6
1,500-100,000	--	--	5	6
(B) Limits for General Population / Uncontrol Exposures				
300-1,500	--	--	F/1500	6
1,500-100,000	--	--	1	30

9.1 Friis Formula

Friis transmission formula : $P_d = (P_{out} * G) / (4 * \pi * r^2)$

Where

P_d = power density in mW/cm²

P_{out} = output power to antenna in mW

G = gain of antenna in linear scale

$P_i = 3.1416$

r = distance between observation point and center of the radiator in cm

P_d is the limit of MPE, 1 mW/cm². If we know the maximum gain of the antenna and the total power input to the antenna, through the calculation, we will know the distance “r” where the MPE limit is reached.

9.2 EUT Operating Condition

A software provided by client enabled the EUT to transmit and receive data at lowest, middle and highest channel individually.



9.3 Test Result of RF Exposure Evaluation

Test Item : RF Exposure Evaluation Data
Test Mode : Normal Operation

9.3.1 Antenna Gain

Antenna Gain : The maximum Gain measured in fully anechoic chamber is 1.8dBi linear scale.

9.3.2 Output Power into Antenna & RF Exposure Evaluation Distance

Channel	Channel Frequency (MHz)	Output Peak Power to Antenna (dBm)	Antenna Gain	Power Density at 20cm (mW/cm ²)	LIMITS (mW/cm ²)
CH1	2412.00	23.20	1.8	0.041565	1
CH6	2437.00	23.14	1.8	0.040995	1
CH11	2462.00	23.59	1.8	0.045471	1

Note :

1. For 802.11b mode (11Mbps).
2. The power density Pd (4th column) at a distance of 20cm calculated from the friis transmission formula is far below the limit of 1 mW/cm² . The EUT is classified as mobile product. So, RF exposure limit warning or SAR test are not required.

Channel	Channel Frequency (MHz)	Output Peak Power to Antenna (dBm)	Antenna Gain	Power Density at 20cm (mW/cm ²)	LIMITS (mW/cm ²)
CH1	2412.00	19.03	1.8	0.015912	1
CH6	2437.00	19.47	1.8	0.017609	1
CH11	2462.00	19.12	1.8	0.016245	1

Note :

1. For 802.11g mode (54Mbps).
2. The power density Pd (4th column) at a distance of 20cm calculated from the friis transmission formula is far below the limit of 1 mW/cm² . The EUT is classified as mobile product. So, RF exposure limit warning or SAR test are not required.