



FCC 47 CFR PART 15 SUBPART C: 2008 AND ANSI C63.4: 2003

TEST REPORT

For

AirCruiser Extreme N Router

Model Number: GN-BR33V-RH

Data Applies To: GN-BR33N-RH

Brand Name: GIGA-BYTE

Issued for

GIGA-BYTE TECHNOLOGY CO., LTD.

No.6, Bau Chiang Road, Hsin-Tien, Taipei Hsien, Taiwan, R.O.C.

Issued by

Compliance Certification Services Inc.

Tainan Lab.

No. 8, Jiu Cheng Ling, Jiaokeng Village, Sinhua

Township, Tainan Hsien 712, Taiwan R.O.C.

TEL: 886-6-580-2201

FAX: 886-6-580-2202



Note: This report shall not be reproduced except in full, without the written approval of Compliance Certification Services Inc. Ltd. This document may be altered or revised by Compliance Certification Services Inc. personnel only, and shall be noted in the revision section of the document



REVISION HISTORY

Rev.	Issue Date	Revisions	Effect Page	Revised By
00	May 13, 2009	Initial Issue	ALL	Leah Peng



TABLE OF CONTENTS

1. TEST REPORT CERTIFICATION	4
2. EUT DESCRIPTION	5
2.1 DESCRIPTION OF EUT & POWER	5
3. DESCRIPTION OF TEST MODES	7
4. TEST METHODOLOGY	8
5. FACILITIES AND ACCREDITATIONS	8
5.1 FACILITIES	8
5.2 EQUIPMENT	8
5.3 LABORATORY ACCREDITATIONS LISTINGS	8
5.4 TABLE OF ACCREDITATIONS AND LISTINGS	9
6. CALIBRATION AND UNCERTAINTY	10
6.1 MEASURING INSTRUMENT CALIBRATION	10
6.2 MEASUREMENT UNCERTAINTY	10
7. SETUP OF EQUIPMENT UNDER TEST	11
7.1 SETUP CONFIGURATION OF EUT	11
7.2 SUPPORT EQUIPMENT	11
7.3 EUT OPERATING CONDITION	12
8. APPLICABLE LIMITS AND TEST RESULTS	13
8.1 6DB BANDWIDTH	13
8.2 MAXIMUM PEAK OUTPUT POWER	28
8.3 MAXIMUM PERMISSIBLE EXPOSURE	43
8.4 POWER SPECTRAL DENSITY	45
8.5 CONDUCTED SPURIOUS EMISSION	64
8.6 RADIATED EMISSIONS	89
8.7 POWERLINE CONDUCTED EMISSIONS	136
9. ANTENNA REQUIREMENT	140
9.1 STANDARD APPLICABLE	140
9.2 ANTENNA CONNECTED CONSTRUCTION	140
APPENDIX SETUP PHOTOS	141



1. TEST REPORT CERTIFICATION

Applicant : GIGA-BYTE TECHNOLOGY CO., LTD.
Address : No.6, Bau Chiang Road, Hsin-Tien, Taipei Hsien, Taiwan, R.O.C.
Manufacture : GIGA-BYTE TECHNOLOGY CO., LTD.
Address : No.6, Bau Chiang Road, Hsin-Tien, Taipei Hsien, Taiwan, R.O.C.
Equipment Under Test : AirCruiser Extreme N Router
Model Number : GN-BR33V-RH
Data Applies To : GN-BR33N-RH
Brand Name : GIGA-BYTE
Date of Test : March 18, 2009, April 29, 2009

APPLICABLE STANDARD	
STANDARD	TEST RESULT
FCC Part 15 Subpart C : 2008 AND ANSI C63.4 : 2003	No non-compliance noted

Approved by:

Jeter Wu
 Section Manager
 Compliance Certification Services Inc.

Reviewed by:

Eric Yang
 Senior Engineer
 Compliance Certification Services Inc.



2. EUT DESCRIPTION

2.1 DESCRIPTION OF EUT & POWER

Product Name	AirCruiser Extreme N Router	
Model Number	GN-BR33V-RH	
Data Applies To	GN-BR33N-RH	
Mode Difference	GN-BR33V-RH With USB port	GN-BR33N-RH Without USB port
Brand Name	GIGA-BYTE	
Frequency Range	IEEE 802.11b/g, 802.11n HT20 (DTS Band):2412MHz~2462MHz IEEE 802.11n HT40 (DTS Band):2422MHz~2452MHz	
Transmit Power	IEEE 802.11b Mode : 26.03dBm (DTS Band) (400.87 mW) IEEE 802.11g Mode : 23.44dBm (DTS Band) (220.8 mW) IEEE 802.11n HT20 Mode : 26.57dBm (DTS Band) (453.86 mW) IEEE 802.11n HT40 Mode : 25.85dBm (DTS Band) (384.78 mW)	
Channel Spacing	IEEE 802.11b/g, 802.11n HT20/HT40: 5MHz	
Channel Number	IEEE 802.11b/g, 802.11n HT20:11 Channels IEEE 802.11n HT40 :7 Channels	
Transmit Data Rate	IEEE 802.11b:11, 5.5, 2, 1Mbps	
	IEEE 802.11g : 54, 48, 36, 24, 18, 12, 11, 9, 6Mbps	
	IEEE 802.11n HT20 : 135, 121.5, 108, 81, 27, 13.5Mbps	
	IEEE 802.11n HT40 : 300, 270, 243, 216, 162, 135, 121.5, 108, 81, 27, 13.5 Mbps	
Type of Modulation	IEEE 802.11b : DSSS (CCK, DQPSK, DBPSK)	
	IEEE 802.11g : OFDM (64QAM, 16QAM, QPSK, BPSK)	
	IEEE 802.11n HT20/40 : OFDM (64QAM, 16QAM, QPSK, BPSK)	
Frequency Selection	By software / firmware	
Antenna Type	Dipole Antenna (× 2) 2T2R Manufacture: ARISTOTLE ENTERPRISES INC. Model: RFA-02-C14H1-70B120C Gain: 3.07dBi Connector: I-PEX	
Power Source	Powered from AC adapter Model: PGA-011B Brand: EPS Input: 100-240Vac, 47-63Hz, 0.5A Output: 5Vdc, 2.2A	



Temperature Range	0 ~ +55°C
--------------------------	-----------

- REMARK:** 1. The sample selected for test was engineering sample that approximated to production product and was provided by manufacturer.
2. This submittal(s) (test report) is intended for FCC ID: JCK-GN-BR33V-RH filing to comply with Section 15.207,15.209 and 15.247 of the FCC Part 15, Subpart C Rules.

3. DESCRIPTION OF TEST MODES

The EUT is an 802.11n MIMO transceiver router. It has two transmitter chains and two receive chains (2x2 configurations). The 2x2 configuration is implemented with two outside chains (Chain 0 and 1)

The antenna peak gain 3.07dBi (highest gain) were chosen for full testing.

The RF chipset is manufactured by Ralink Technology, Corp.

11b/g mode, only examines Chain 0, because only Chain 0 is functional according to the user diver of Ralink.

The power is transmitted from TX0 only at 11b/g normal mode in Ralink solution.

IEEE 802.11 b ,802.11g ,802.11n HT20 mode (DTS Band)

The EUT had been tested under operating condition.

There are three channels have been tested as following:

Channel	Frequency (MHz)
Low	2412
Middle	2437
High	2462

IEEE 802.11b mode: 11Mbps data rate (worst case) were chosen for full testing.

IEEE 802.11g mode: 6Mbps data rate (worst case) were chosen for full testing.

IEEE 802.11n HT20 mode: 13.5Mbps data rate (worst case) were chosen for full testing.

IEEE 802.11n HT40 mode (DTS Band)

The EUT had been tested under operating condition.

There are three channels have been tested as following:

Channel	Frequency (MHz)
Low	2422
Middle	2437
High	2452

IEEE 802.11n HT40 mode: 13.5Mbps data rate (worst case) were chosen for full testing.

The worst-case data rates are determined according to the description above, based on the investigations by measuring the PSD, peak power and average power across all the data rates, bandwidths, modulations and spatial stream modes.



4. TEST METHODOLOGY

The tests documented in this report were performed in accordance with ANSI C63.4 and FCC CFR 47 15.207, 15.209 and 15.247.

5. FACILITIES AND ACCREDITATIONS

5.1 FACILITIES

All measurement facilities used to collect the measurement data are located at

No. 8, Jiu Cheng Ling, Jiaokeng Village, Sinhua Township, Tainan Hsien 712, Taiwan R.O.C.

The sites are constructed in conformance with the requirements of ANSI C63.7:1992, ANSI C63.4: 2003 and CISPR Publication 22.

5.2 EQUIPMENT

Radiated emissions are measured with one or more of the following types of linearly polarized antennas: tuned dipole, biconical, log periodic, bi-log, and/or ridged waveguide, horn. Spectrum analyzers with preselectors and quasi-peak detectors are used to perform radiated measurements.

Conducted emissions are measured with Line Impedance Stabilization Networks and EMI Test Receivers.





Calibrated wideband preamplifiers, coaxial cables, and coaxial attenuators are also used for making measurements.

All receiving equipment conforms to CISPR Publication 16-1, "Radio Interference Measuring Apparatus and Measurement Methods."

5.3 LABORATORY ACCREDITATIONS LISTINGS

The test facilities used to perform radiated and conducted emissions tests are accredited by Taiwan Accreditation Foundation for the specific scope of accreditation under Lab Code: 1109 to perform Electromagnetic Interference tests according to FCC PART 15 AND CISPR 22 requirements. No part of this report may be used to claim or imply product endorsement by TAF or any agency of the Government. In addition, the test facilities are listed with Federal Communications Commission (registration no: TW-1037 and 455173).

5.4 TABLE OF ACCREDITATIONS AND LISTINGS

Country	Agency	Scope of Accreditation	Logo
USA	FCC	3/10 meter Open Area Test Sites to perform FCC Part 15/18 measurements	 455173 TW-1037
Japan	VCCI	3/10 meter Open Area Test Sites and conducted test sites to perform radiated/conducted measurements	 C-2882 R-2635
Taiwan	TAF	CISPR 11, FCC METHOD-47 CFR Part 18, EN 55011, EN 60601-1-2, CISPR 22, CNS 13438, EN 55022, EN 55024, AS/NZS CISPR 22 CISPR 14, EN 55014-1, EN 55014-2, CNS 13783-1, CISPR 22, CNS 13439, EN 55013, FCC Method-47 CFR Part 15 Subpart B, IC ICES-003, VCCI V-3 & V-4 FCC Method-47 CFR Part 15 Subpart C and ANSI C63.4, LP 0002 EN / IEC 61000-4-2 / -3 / -4 / -5 / -6 / -8 / -11 EN 61000-3-2, EN 61000-3-3 EN 61000-6-3, EN 61000-6-1, AS/NZS 4251.1, EN 61000-6-4, EN 61000-6-2, AS/NZS 4251.2, EN 61204-3, EN 50130-4, EN 62040-2, EN 50371, EN 50385, AS/NZS 4268, ETSI EN 300 386 ETSI EN 300 328, ETSI EN 301 489-1/-3/-9/-17 ETSI EN 301 893, ETSI EN 300 220-2/-1 ETSI EN 300 440-2/-1 ETSI EN 301 357-2/-1 RSS-310, RSS-210 Issue 7, RSS-Gen Issue 2	
Taiwan	BSMI	CNS 13438, CNS 13783-1, CNS13439	 SL2-IN-E-0039 SL2-R1/R2-0039 SL2-A1-E-0039
Canada	Industry Canada	RSS210, Issue 7	 IC 2324H-I

* No part of this report may be used to claim or imply product endorsement by TAF or any agency of the US Government.



6. CALIBRATION AND UNCERTAINTY

6.1 MEASURING INSTRUMENT CALIBRATION

The measuring equipment utilized to perform the tests documented in this report has been calibrated in accordance with the manufacturer's recommendations, and is traceable to recognized national standards.

6.2 MEASUREMENT UNCERTAINTY

Where relevant, the following measurement uncertainty levels have been estimated for tests performed on the apparatus:

PARAMETER	UNCERTAINTY
Radiated Emission, 30 to 1000 MHz	+/- 3.2 dB
Radiated Emission, 1 to 26.5 GHz	+/- 3.2 dB
Power Line Conducted Emission	+/- 2.1 dB

This measurement uncertainty is confidence of approximately 95%, k=2

7. SETUP OF EQUIPMENT UNDER TEST

7.1 SETUP CONFIGURATION OF EUT

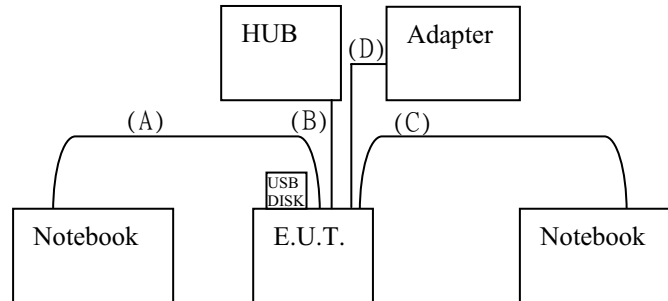

7.2 SUPPORT EQUIPMENT

No.	Product	Manufacturer	Model No.	Certify No.	Signal cable
1	HUB	LEMEL	LM-S5M4C	DOC	Power cable, unshd, 1.6m
2	Note Book	HP	CNC 6000	CNTPP2090	Power cable, unshd, 1.6m
3	Note Book	IBM	T43	DOC	Power cable, unshd, 1.6m
4	USB Disk	Transcend	128M	DOC	N/A

No.	Signal cable description	
A	LAN cable	Unshielded, 6m, 1pcs.
B	LAN cable	Unshielded, 2m, 3pcs.
C	LAN cable	Unshielded, 6m, 1pcs.
D	Power cable	Unshielded, 1.5m, 1pcs.

REMARK:

1. All the above equipment/cables were placed in worse case positions to maximize emission signals during emission test.
2. Grounding was established in accordance with the manufacturer's requirements and conditions for the intended use.



7.3 EUT OPERATING CONDITION

RF Setup

1. Set up all notebooks like the setup diagram.
2. The “**Ralink QA Test Program for RT3052QA**” software was used for testing
The EUT driver software installed in the host support equipment during testing was Ralink QA Test Program for RT3052QA Drive

(1) TX Mode:

⇒ **Tx Mode:CCK 、 OFDM 、 HT MixMode** (Bandwidth: 20 、 40)

⇒ **Tx Data Rate: 11Mbps long** (IEEE 802.11b mode)

6Mbps (IEEE 802.11g mode)

13.5Mbps (IEEE 802.11n HT20 mode)

13.5Mbps (IEEE 802.11n HT40 mod)

Power control mode

Target Power: IEEE 802.11b Channel Low (2412MHz) = **1A (Chain0)**

IEEE 802.11b Channel Middle (2437MHz) = **1B (Chain0)**

IEEE 802.11b Channel High (2462MHz) = **1C (Chain0)**

Target Power: IEEE 802.11g Channel Low (2412MHz) = **1A (Chain0)**

IEEE 802.11g Channel Middle (2437MHz) = **1B (Chain0)**

IEEE 802.11g Channel High (2462MHz) = **1D (Chain0)**

Target Power: IEEE 802.11n HT20 Channel Low (2412MHz) = **1A (Chain0)**

IEEE 802.11n HT20 Channel Low (2412MHz) = **1B (Chain1)**

IEEE 802.11 n HT20 Channel Middle (2437MHz) = **15 (Chain0)**

IEEE 802.11 n HT20 Channel Middle (2437MHz) = **17 (Chain1)**

IEEE 802.11 n HT20 Channel High (2462MHz) = **19 (Chain0)**

IEEE 802.11 n HT20 Channel High (2462MHz) = **19 (Chain1)**

Target Power: IEEE 802.11n HT40 Channel Low (2422MHz) = **17 (Chain0)**

IEEE 802.11n HT40 Channel Low (2422MHz) = **18 (Chain1)**

IEEE 802.11 n HT40 Channel Middle (2437MHz) = **17 (Chain0)**

IEEE 802.11 n HT40 Channel Middle (2437MHz) = **19 (Chain1)**

IEEE 802.11 n HT40 Channel High (2452MHz) = **19 (Chain0)**

IEEE 802.11 n HT40 Channel High (2452MHz) = **1A (Chain1)**

(2) RX Mode :

MAC Address: FFFFFFFF

Start RX

3. All of the function are under run.
4. Start test.

Normal Link Setup

1. Set up all computers like the setup diagram.
2. All of the function are under run.
3. Notebook PC (2) ping 192.168.0.10 –t to Notebook PC (1).
4. Notebook PC (1) ping 192.168.0.20 –t to Notebook PC (2).
5. Notebook PC (1) ping 192.168.0.50 –t to Wireless Access Point (3).

Start test.



8. APPLICABLE LIMITS AND TEST RESULTS

8.1 6DB BANDWIDTH

LIMIT

§ 15.207(a) (2) For direct sequence systems, the minimum 6dB bandwidth shall be at least 500kHz

TEST EQUIPMENTS

Name of Equipment	Manufacturer	Model	Serial Number	Calibration Due
Spectrum Analyzer	R&S	FSEK 30	835253/002	OCT. 14, 2009

TEST SETUP

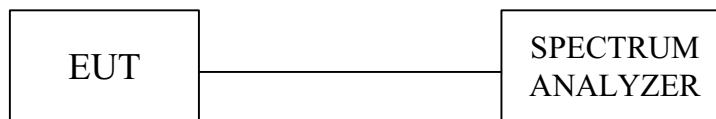

TEST PROCEDURE

The transmitter output was connected to a spectrum analyzer. The bandwidth of the fundamental frequency was measured by spectrum analyzer with 100 KHz RBW and 100 KHz VBW. The 6dB bandwidth is defined as the total spectrum the power of which is higher than peak power minus 6dB.

**TEST RESULTS**

No non-compliance noted.

IEEE 802.11b mode

Channel	Channel Frequency (MHz)	6dB Bandwidth (kHz)	Minimum Limit (kHz)	Pass / Fail
Low	2412	12124	500	PASS
Middle	2437	12224	500	PASS
High	2462	12185	500	PASS

NOTE :

1. At final test to get the worst-case emission at 11Mbps.
2. The cable assembly insertion loss of 11.7dB (including 10 dB pad and 1.7 dB cable) was entered as an offset in the spectrum analyzer to allow for direct reading of power.

IEEE 802.11g mode

Channel	Channel Frequency (MHz)	6dB Bandwidth (kHz)	Minimum Limit (kHz)	Pass / Fail
Low	2412	16633	500	PASS
Middle	2437	16615	500	PASS
High	2462	16628	500	PASS

NOTE :

1. At final test to get the worst-case emission at 6Mbps.
2. The cable assembly insertion loss of 11.7dB (including 10 dB pad and 1.7 dB cable) was entered as an offset in the spectrum analyzer to allow for direct reading of power.

**IEEE 802.11n HT20 mode**

Channel	Channel Frequency (MHz)	6dB Bandwidth Chain 0 (kHz)	6dB Bandwidth Chain 1 (kHz)	Minimum Limit (kHz)	Pass / Fail
Low	2412	17535	17512	500	PASS
Middle	2437	17434	17535	500	PASS
High	2462	17583	17635	500	PASS

- NOTE :**
1. At final test to get the worst-case emission at 13.5Mbps.
 2. The cable assembly insertion loss of 11.7dB (including 10 dB pad and 1.7 dB cable) was entered as an offset in the spectrum analyzer to allow for direct reading of power.

IEEE 802.11n HT40 mode

Channel	Channel Frequency (MHz)	6dB Bandwidth Chain 0 (kHz)	6dB Bandwidth Chain 1 (kHz)	Minimum Limit (kHz)	Pass / Fail
Low	2422	35871	35871	500	PASS
Middle	2437	35924	36072	500	PASS
High	2452	35871	36021	500	PASS

- NOTE :**
1. At final test to get the worst-case emission at 13.5Mbps.
 2. The cable assembly insertion loss of 11.7dB (including 10 dB pad and 1.7 dB cable) was entered as an offset in the spectrum analyzer to allow for direct reading of power.



6dB BANDWIDTH (802.11b MODE)

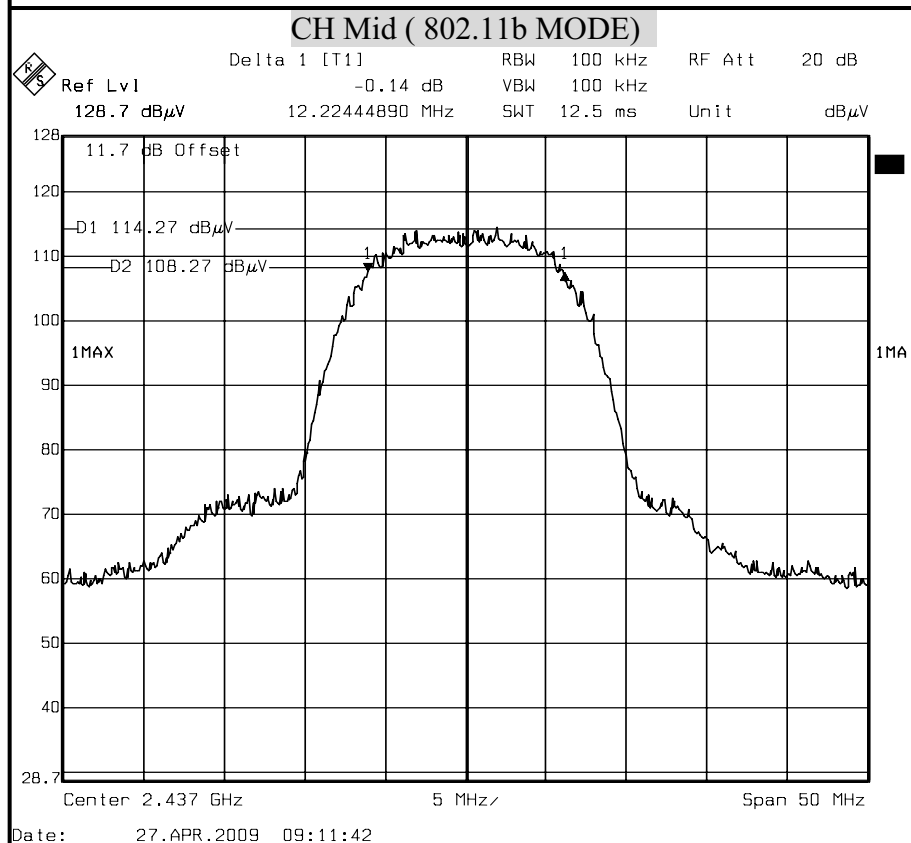
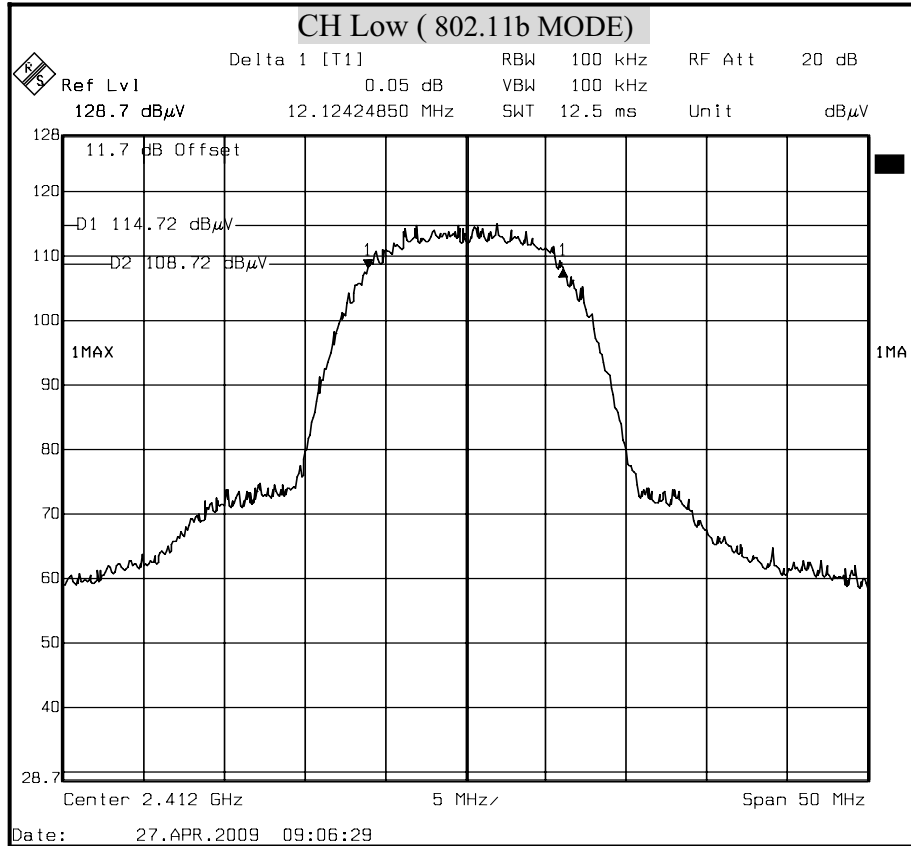

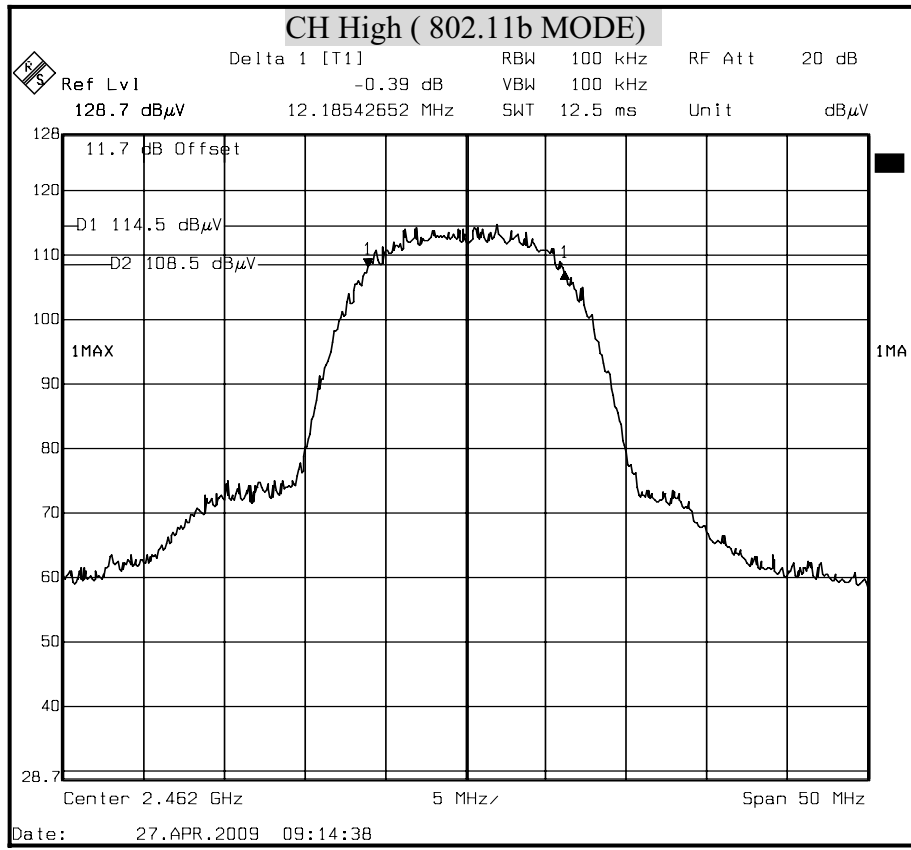



6dB BANDWIDTH (802.11g MODE)

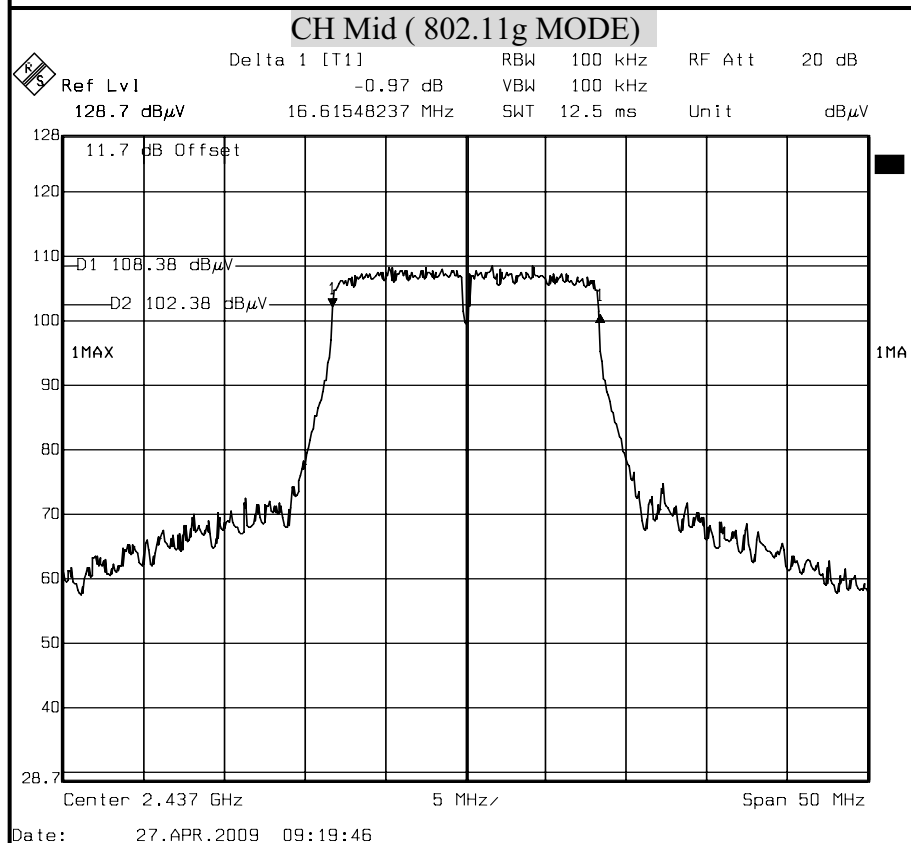
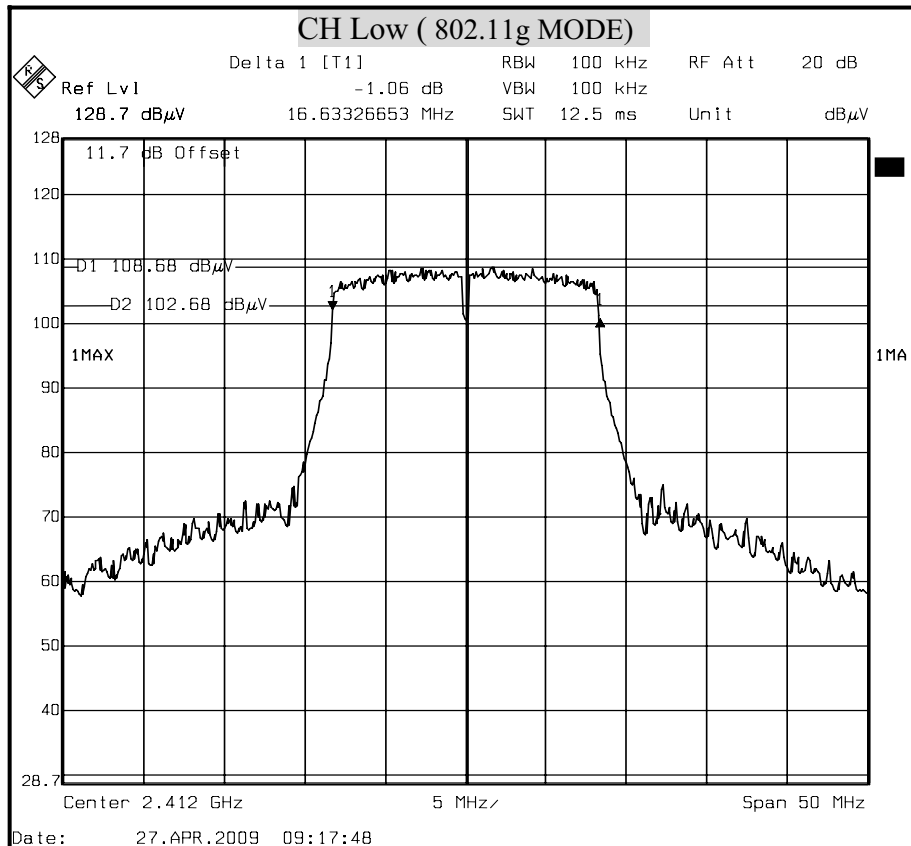

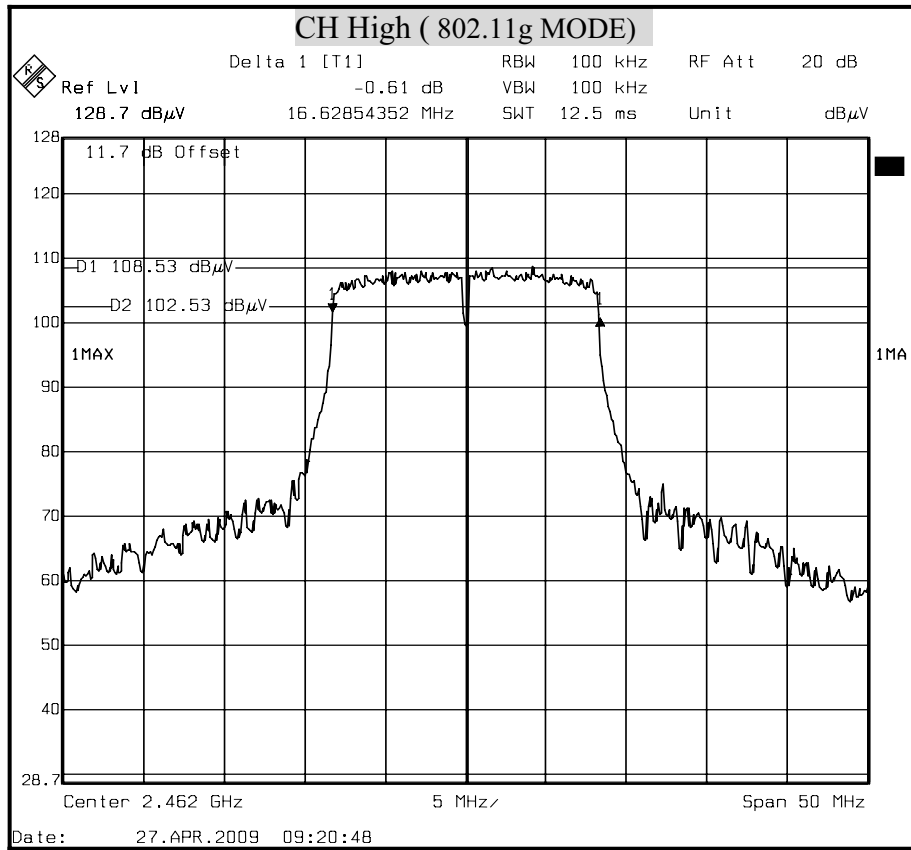



6dB BANDWIDTH (802.11n HT20 MODE) Chain 0

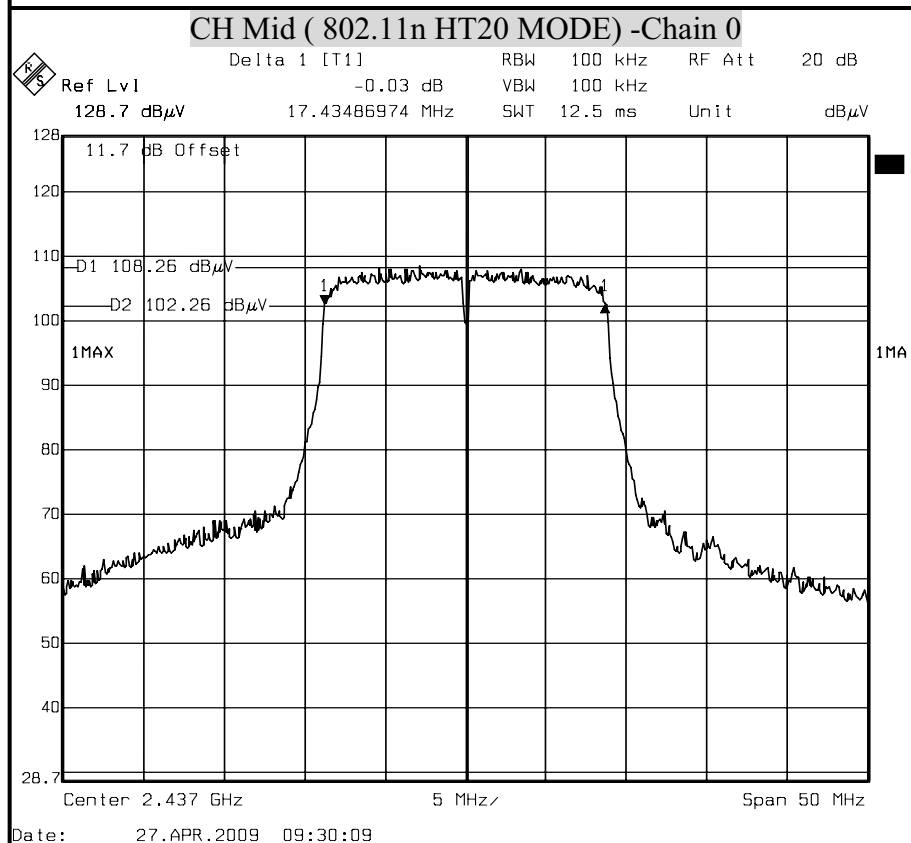
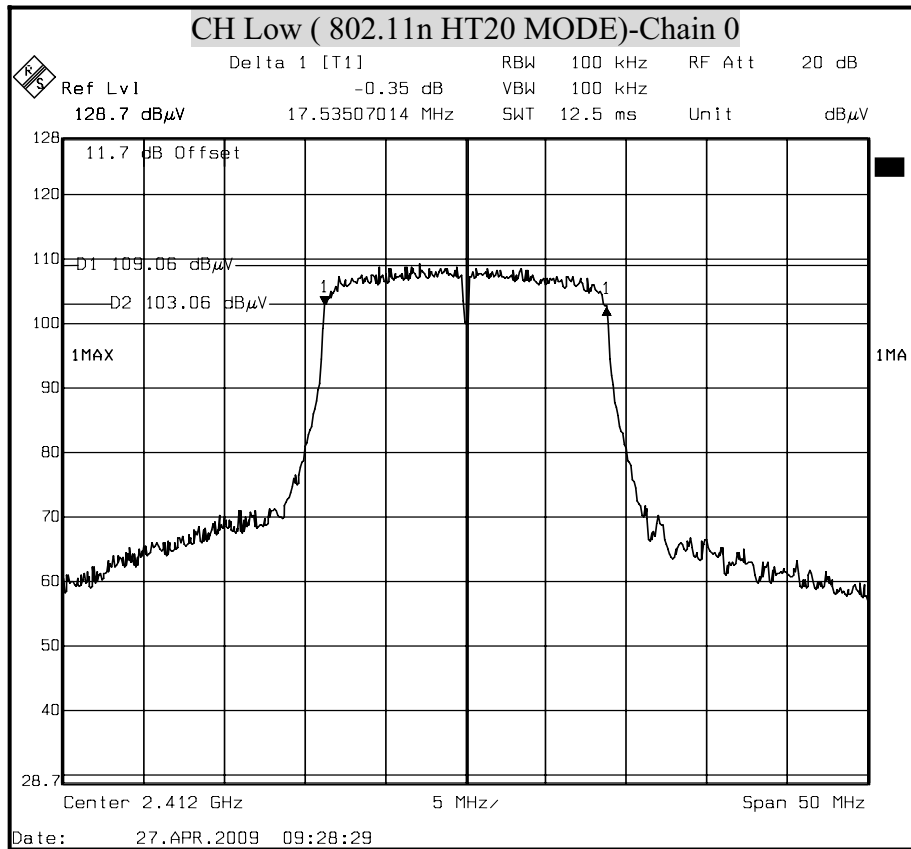

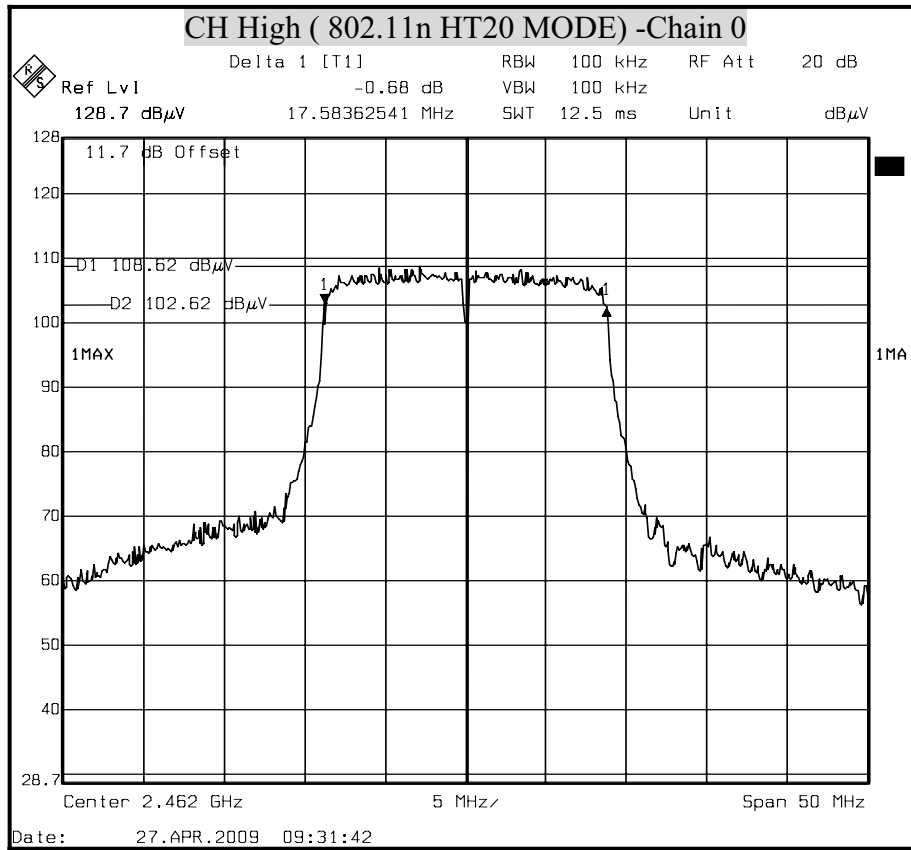



6dB BANDWIDTH (802.11n HT20 MODE) Chain 1

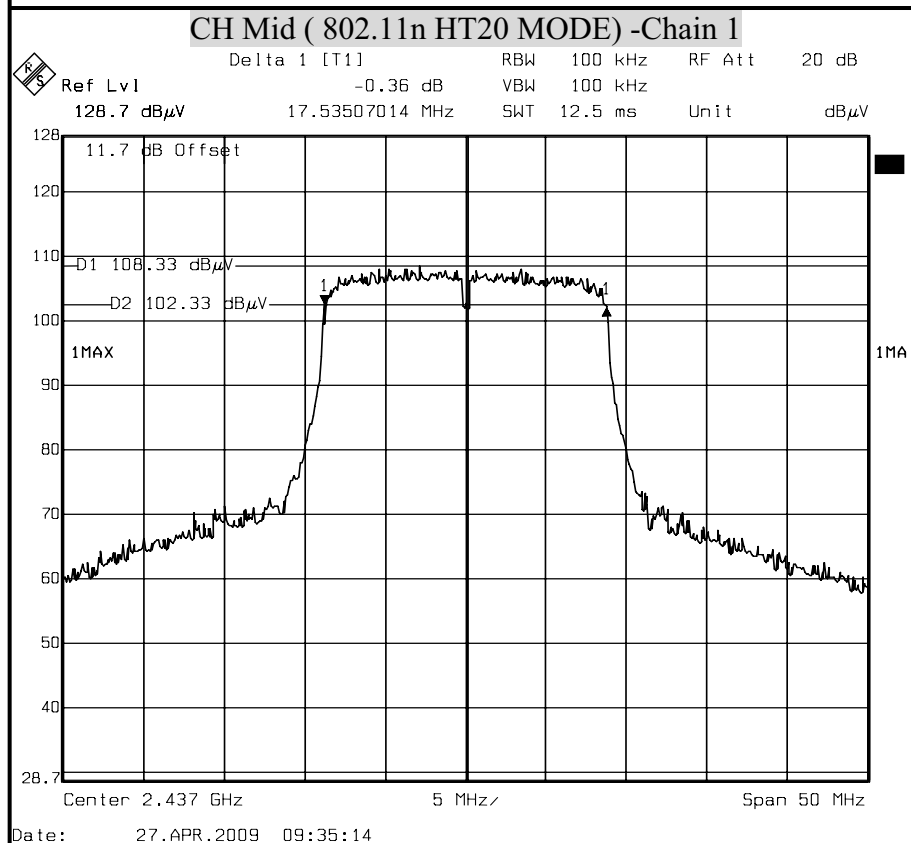
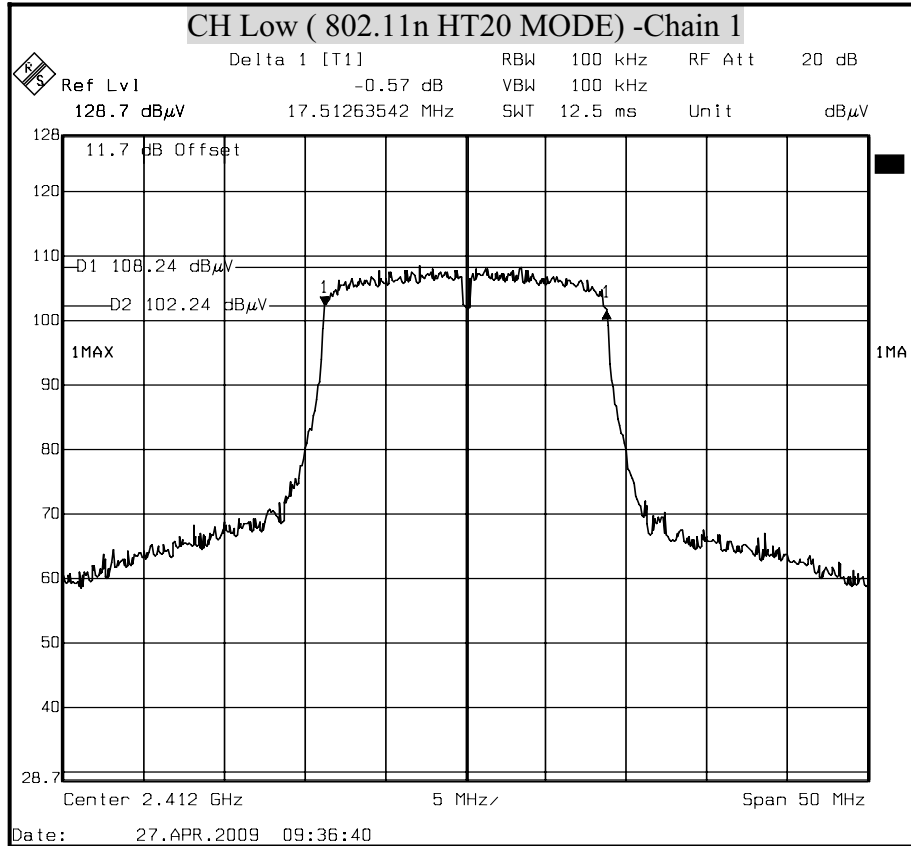

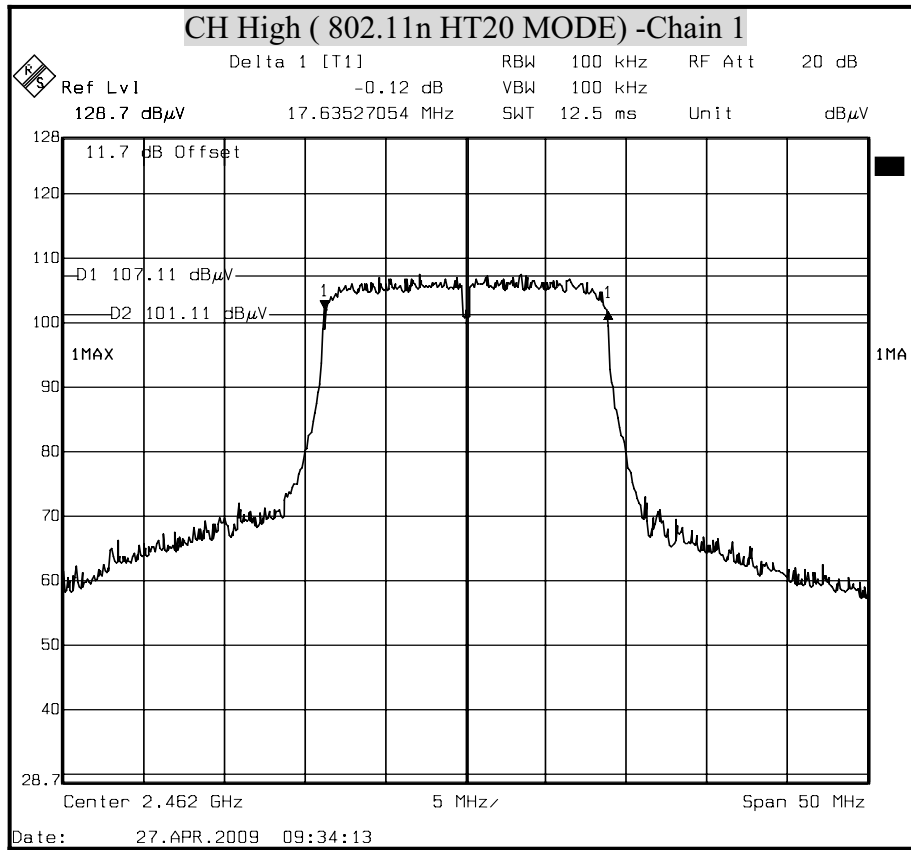



6dB BANDWIDTH (802.11n HT40 MODE) Chain 0

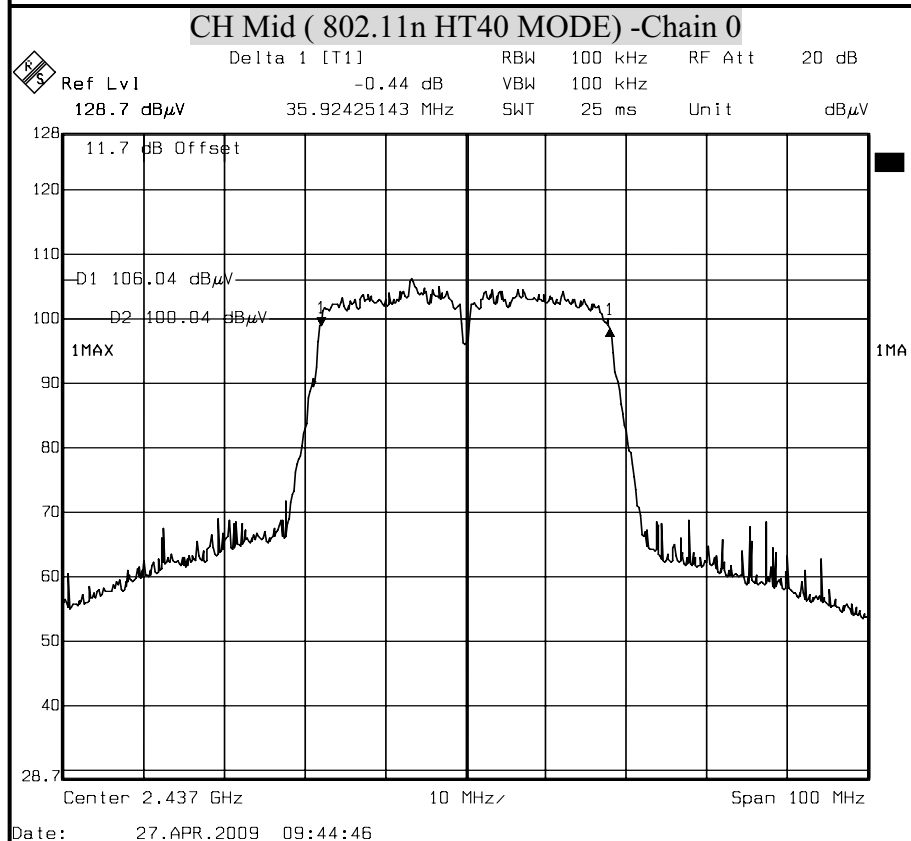
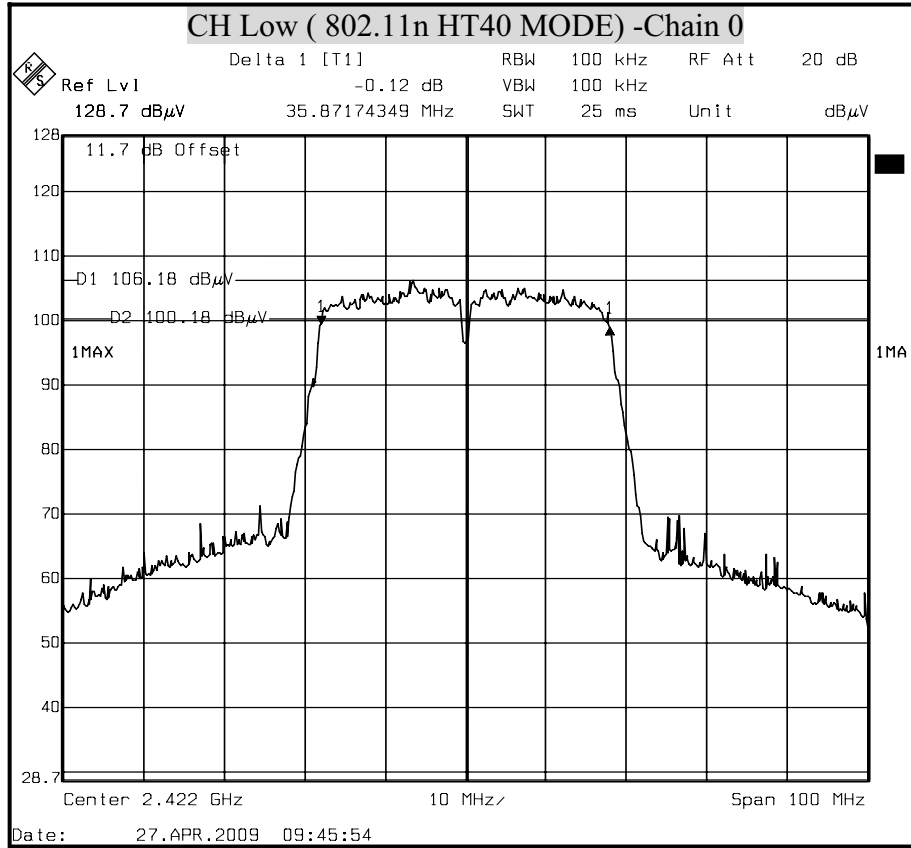

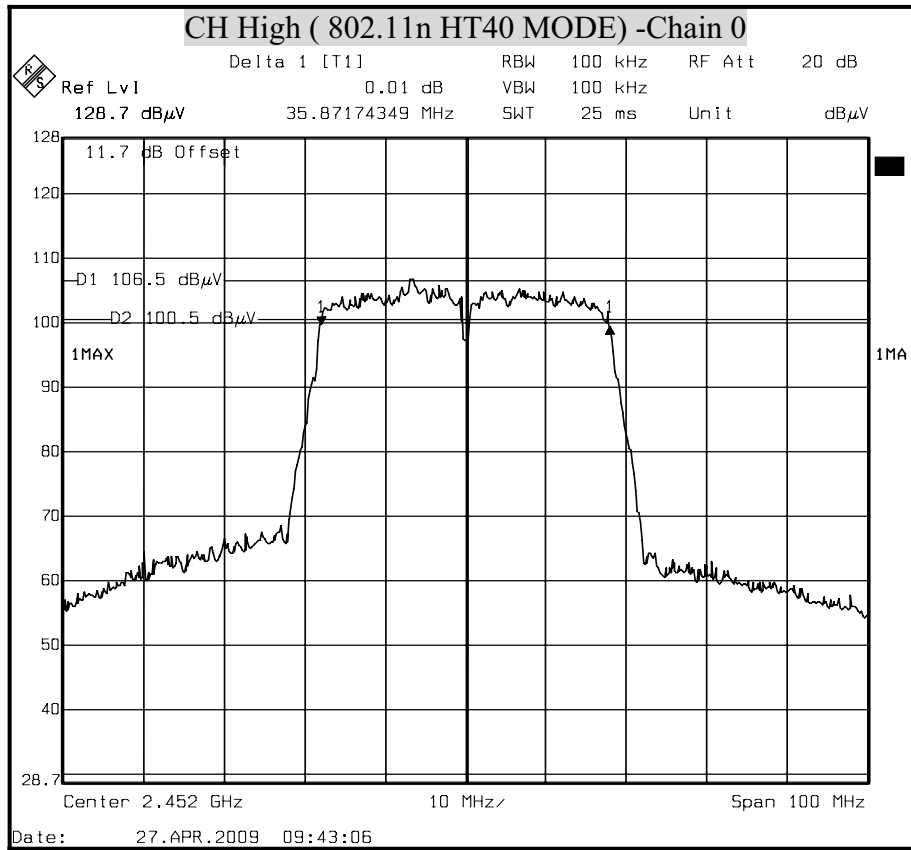



6dB BANDWIDTH (802.11n HT40 MODE) Chain 1

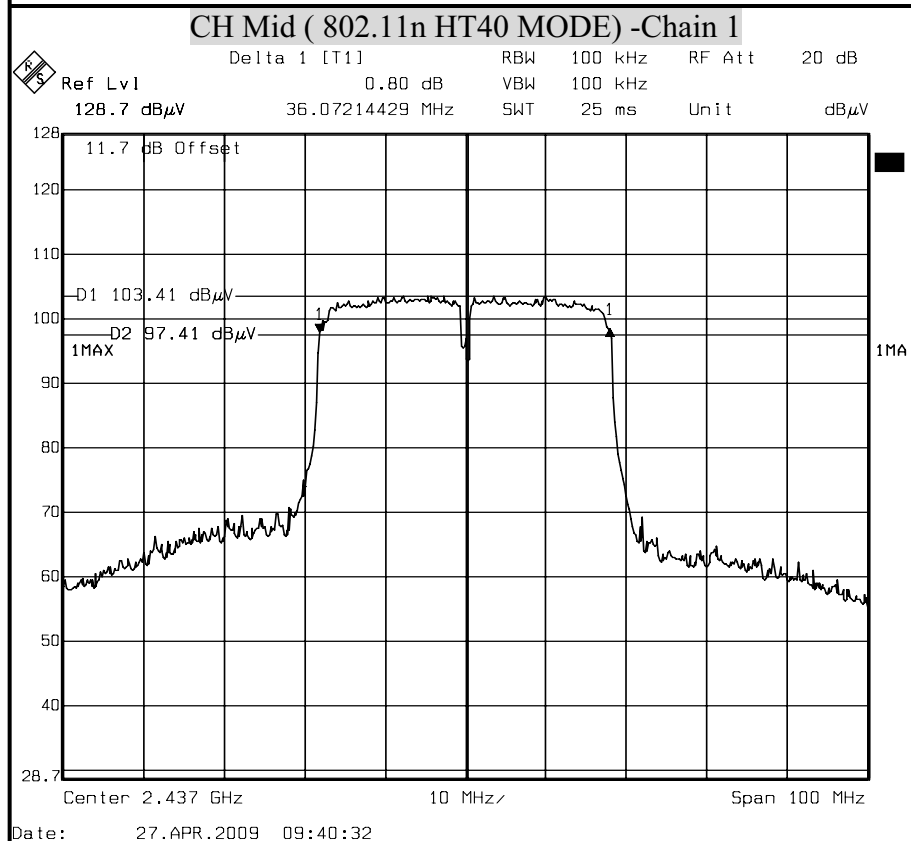
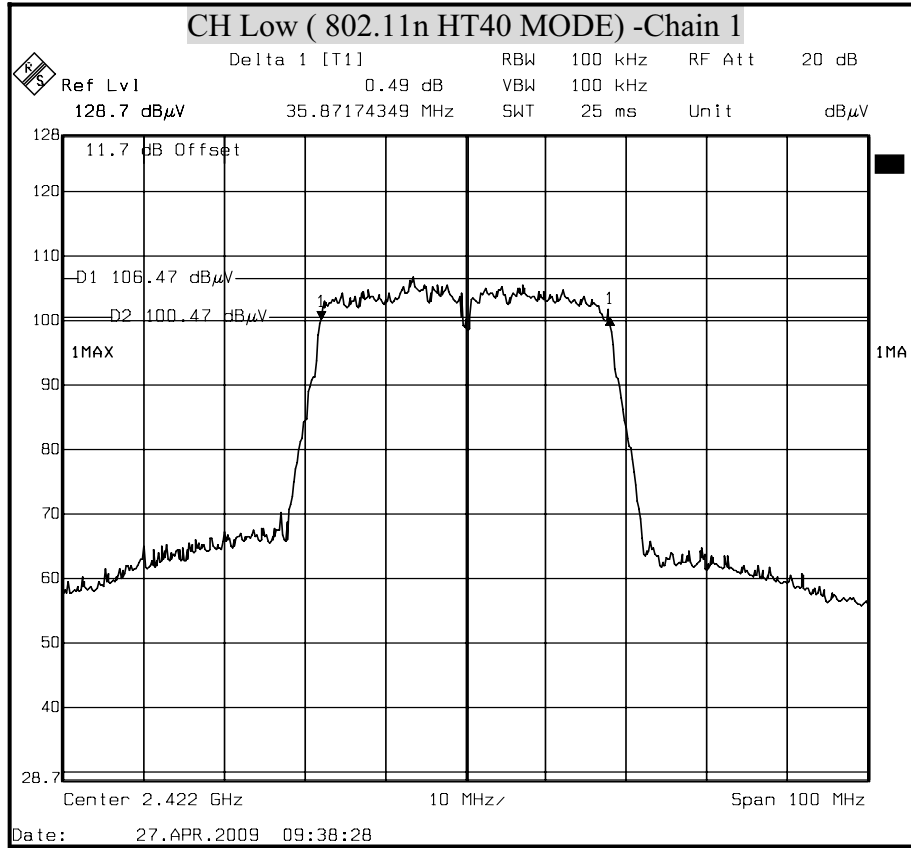

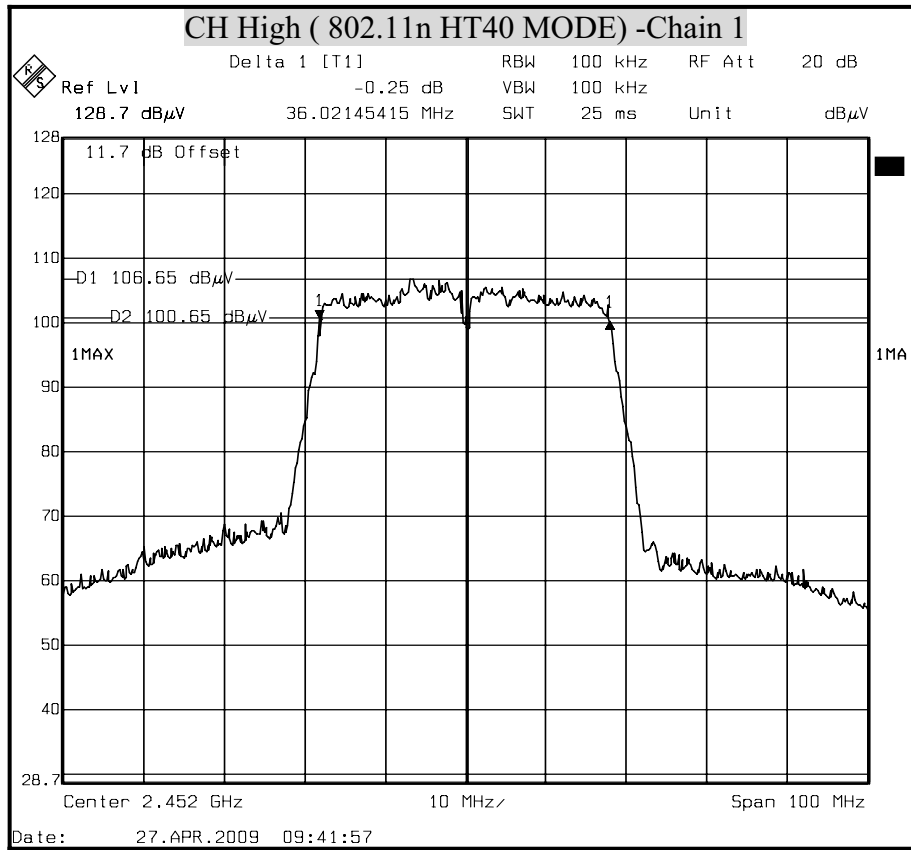

8.2 MAXIMUM PEAK OUTPUT POWER

LIMIT

§ 15.247(b) The maximum peak output power of the intentional radiator shall not exceed the following :

§ 15.247(b) (3) For systems using digital modulation in the 902-928 MHz, 2400-2483.5 MHz, and 5725-5850 MHz bands : 1 watt.

§ 15.247(b) (4) Except as shown in paragraphs (c) of this section , if transmitting antennas of directional gain greater than 6 dBi are used the peak output power from the intentional radiator shall be reduced below the stated values in paragraphs (b)(1) or (b)(2), and (b)(3) of this section , as appropriate, by the amount in dB that the directional gain of the antenna exceeds 6 dBi.

TEST EQUIPMENTS

Name of Equipment	Manufacturer	Model	Serial Number	Calibration Due
Spectrum Analyzer	R&S	FSEK 30	835253/002	OCT. 14, 2009

TEST SETUP

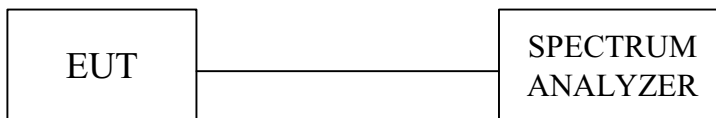

TEST PROCEDURE

Connect the EUT to spectrum analyzer, set the center frequency of the spectrum analyzer to the channel center frequency. Set the RBW to 1MHz and VBW to 3MHz.

Measurement of Digital Transmission Systems Operating under Section 15.247

**TEST RESULTS**

No non-compliance noted

Total peak power calculation formula:

$10 \log (10^{\text{Chain 0 Power} / 10} + 10^{\text{Chain1 Power} / 10})$.

IEEE 802.11b mode

Channel	Channel Frequency (MHz)	Peak Power Chain 0 (dBm)	Peak Power Limit (dBm)	Pass / Fail
Low	2412	25.45	30	PASS
Middle	2437	25.65	30	PASS
High	2462	26.03	30	PASS

NOTE : 1. At final test to get the worst-case emission at 11Mbps.
2. The cable assembly insertion loss of 11.7dB (including 10 dB pad and 1.7 dB cable) was Entered as an offset in the spectrum analyzer to allow for direct reading of power.

IEEE 802.11g mode

Channel	Channel Frequency (MHz)	Peak Power Chain 0 (dBm)	Peak Power Limit (dBm)	Pass / Fail
Low	2412	23.35	30	PASS
Middle	2437	23.44	30	PASS
High	2462	23.36	30	PASS

NOTE : 1. At final test to get the worst-case emission at 6Mbps.
2. The cable assembly insertion loss of 11.7dB (including 10 dB pad and 1.7 dB cable) was Entered as an offset in the spectrum analyzer to allow for direct reading of power.

**IEEE 802.11n HT20 mode**

Channel	Channel Frequency (MHz)	Peak Power Chain 0 (dBm)	Peak Power Chain 1 (dBm)	Peak Power Total (dBm)	Peak Power Limit (dBm)	Pass / Fail
Low	2412	23.74	23.37	26.57	30	PASS
Middle	2437	21.77	21.69	24.74	30	PASS
High	2462	23.17	22.20	25.72	30	PASS

- NOTE :**
1. At final test to get the worst-case emission at 13.5Mbps.
 2. The cable assembly insertion loss of 11.7dB (including 10 dB pad and 1.7 dB cable) was Entered as an offset in the spectrum analyzer to allow for direct reading of power.

IEEE 802.11n HT40 mode

Channel	Channel Frequency (MHz)	Peak Power Chain 0 (dBm)	Peak Power Chain 1 (dBm)	Peak Power Total (dBm)	Peak Power Limit (dBm)	Pass / Fail
Low	2422	22.50	23.07	25.80	30	PASS
Middle	2437	22.29	23.24	25.80	30	PASS
High	2452	22.51	23.15	25.85	30	PASS

- NOTE :**
1. At final test to get the worst-case emission at 13.5Mbps.
 2. The cable assembly insertion loss of 11.7dB (including 10 dB pad and 1.7 dB cable) was Entered as an offset in the spectrum analyzer to allow for direct reading of power.



MAXIMUM PEAK OUTPUT POWER (802.11b MODE)

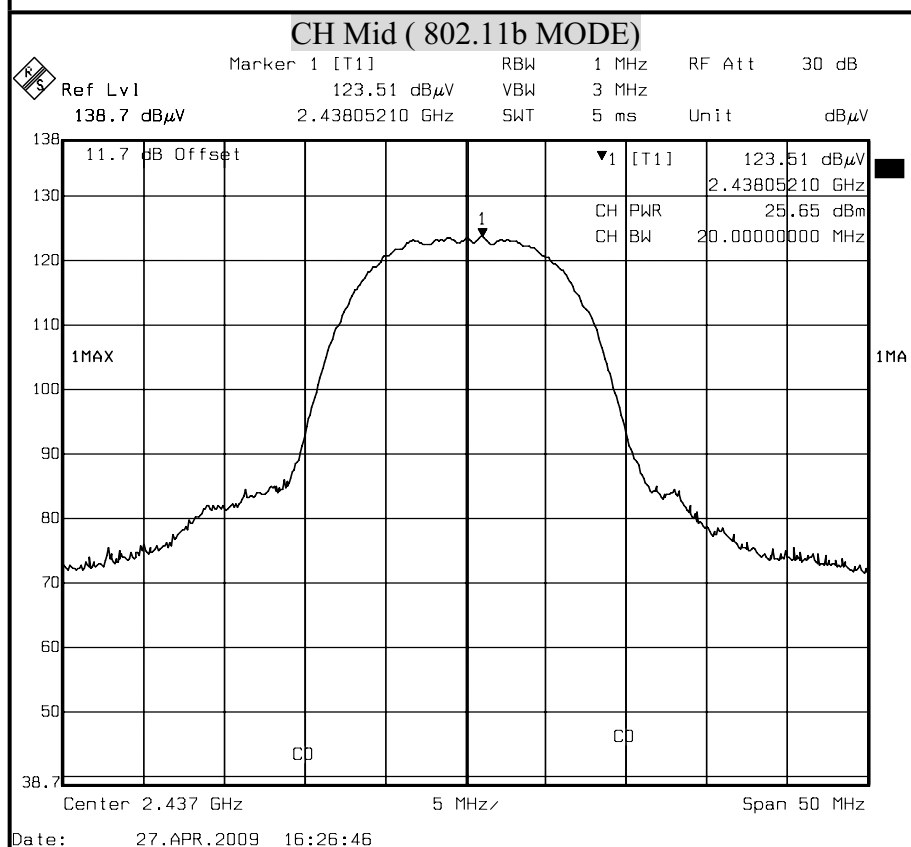
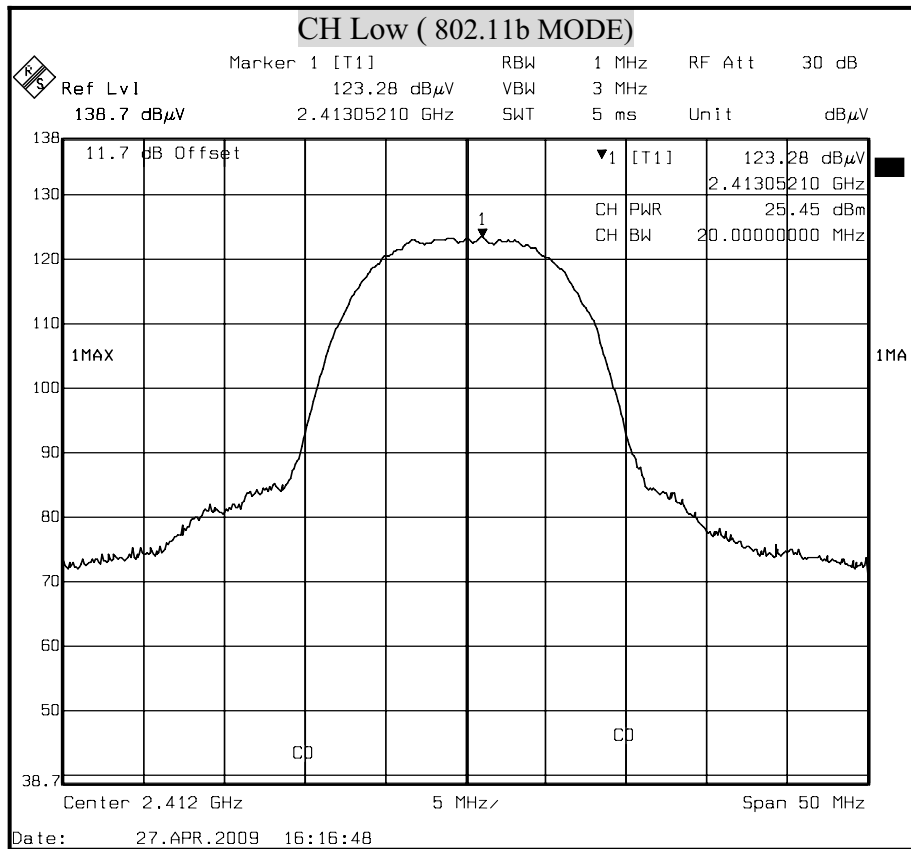

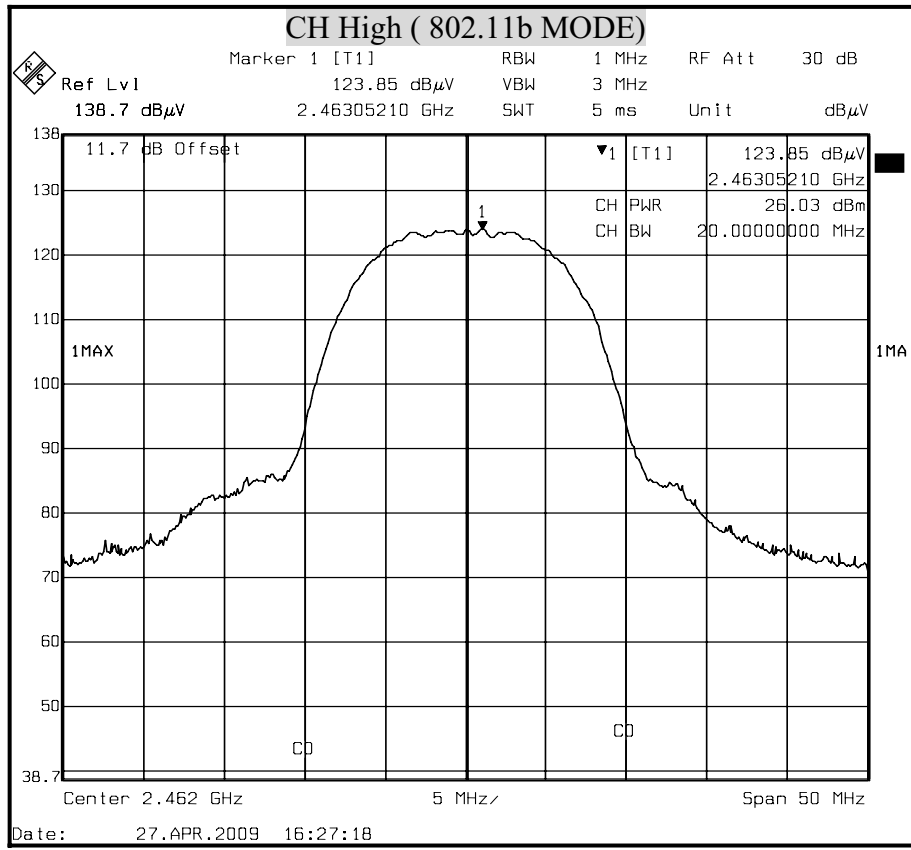



MAXIMUM PEAK OUTPUT POWER (802.11g MODE)

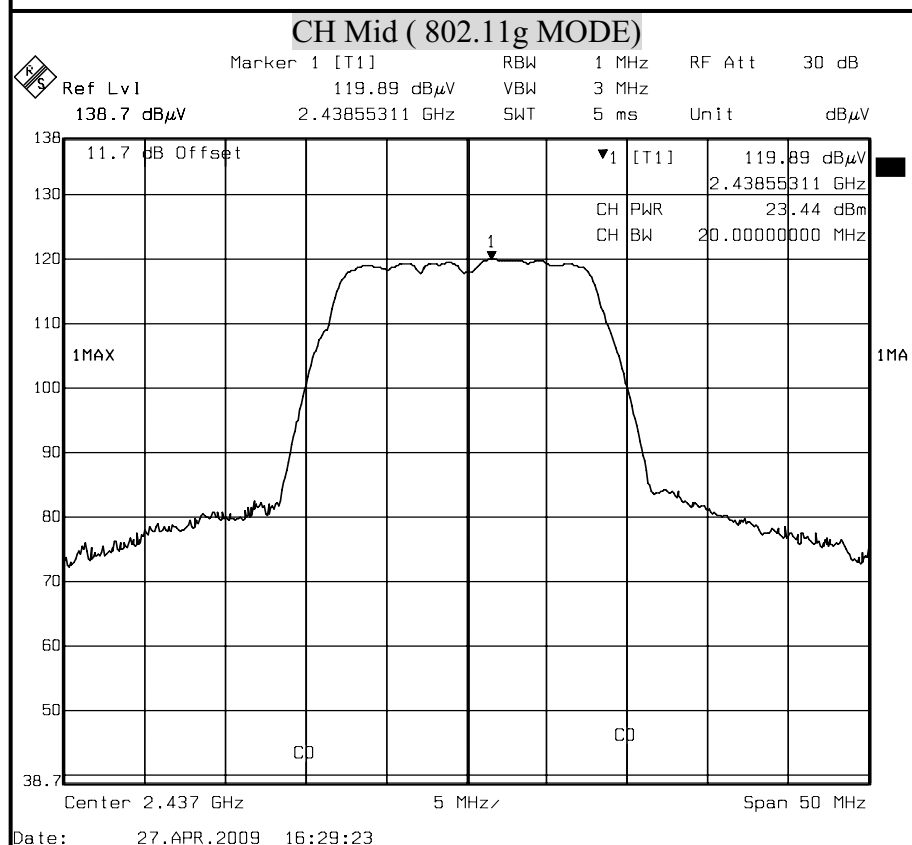
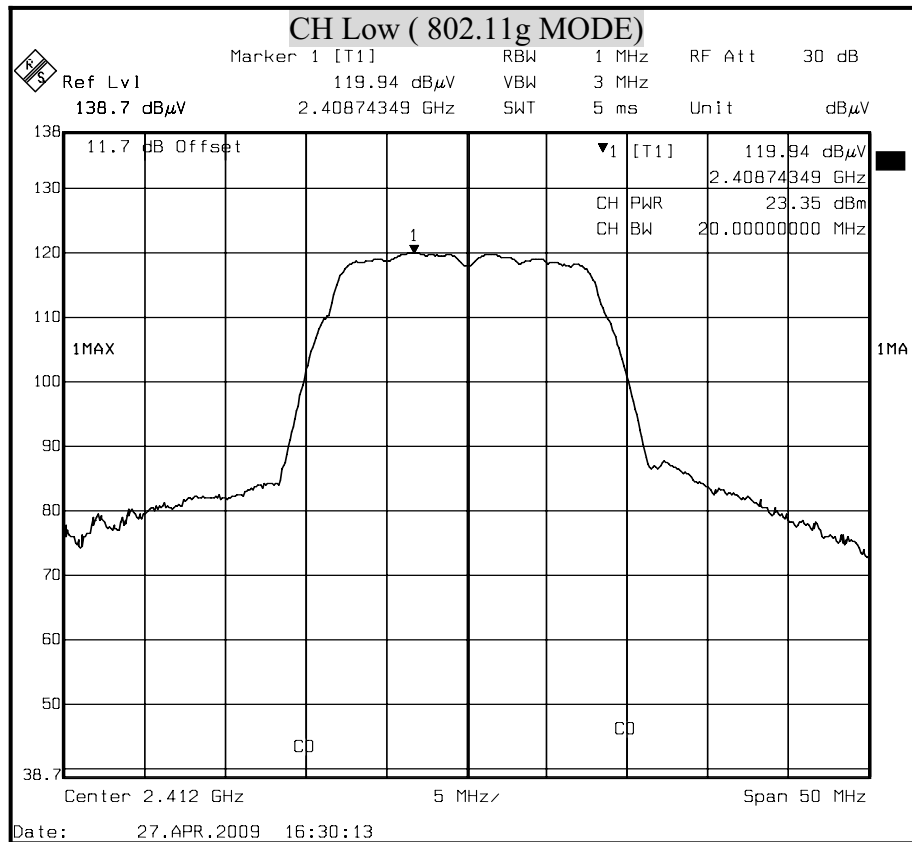

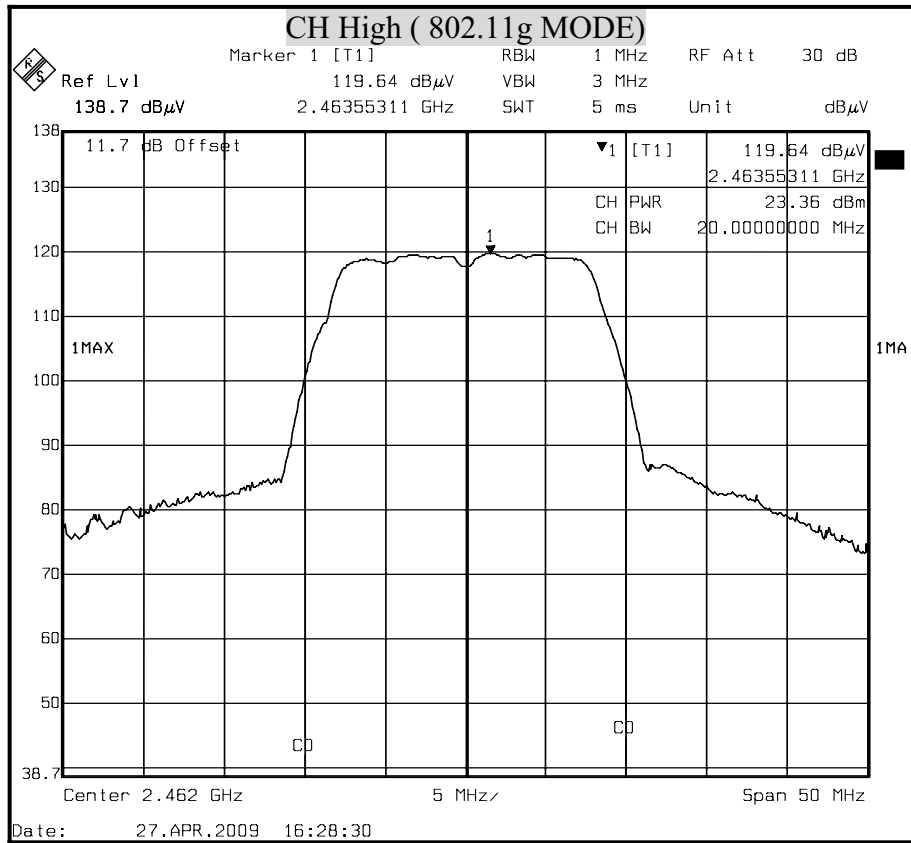



MAXIMUM PEAK OUTPUT POWER (802.11n HT20 MODE) Chain 0

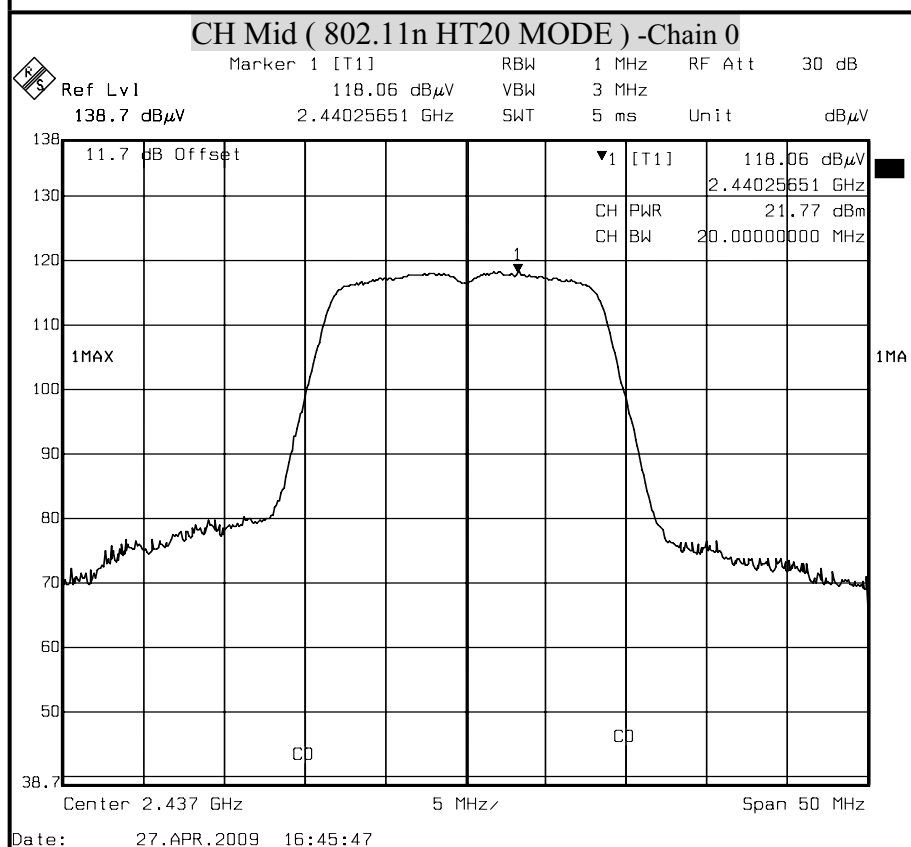
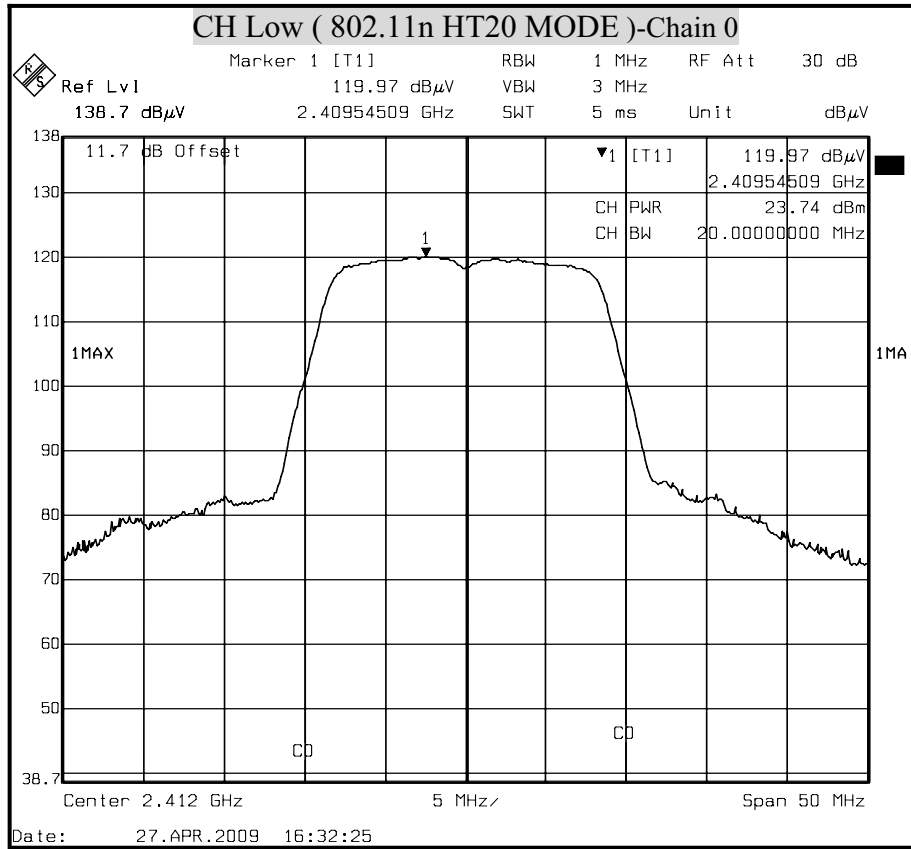

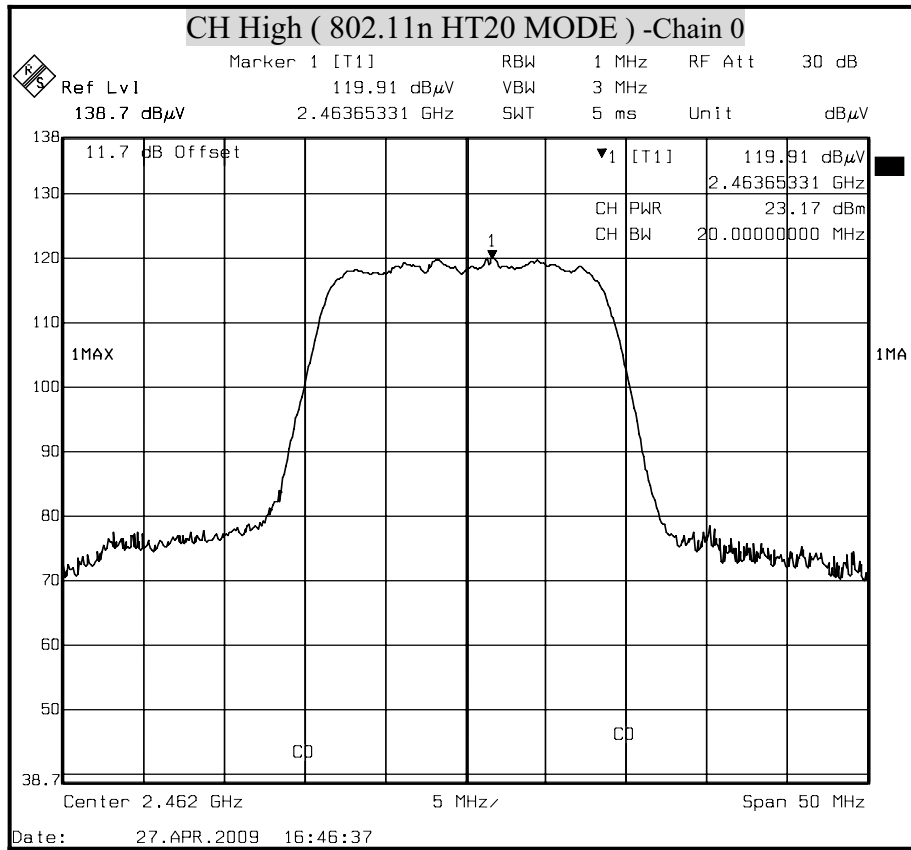



MAXIMUM PEAK OUTPUT POWER (802.11n HT20 MODE) Chain 1

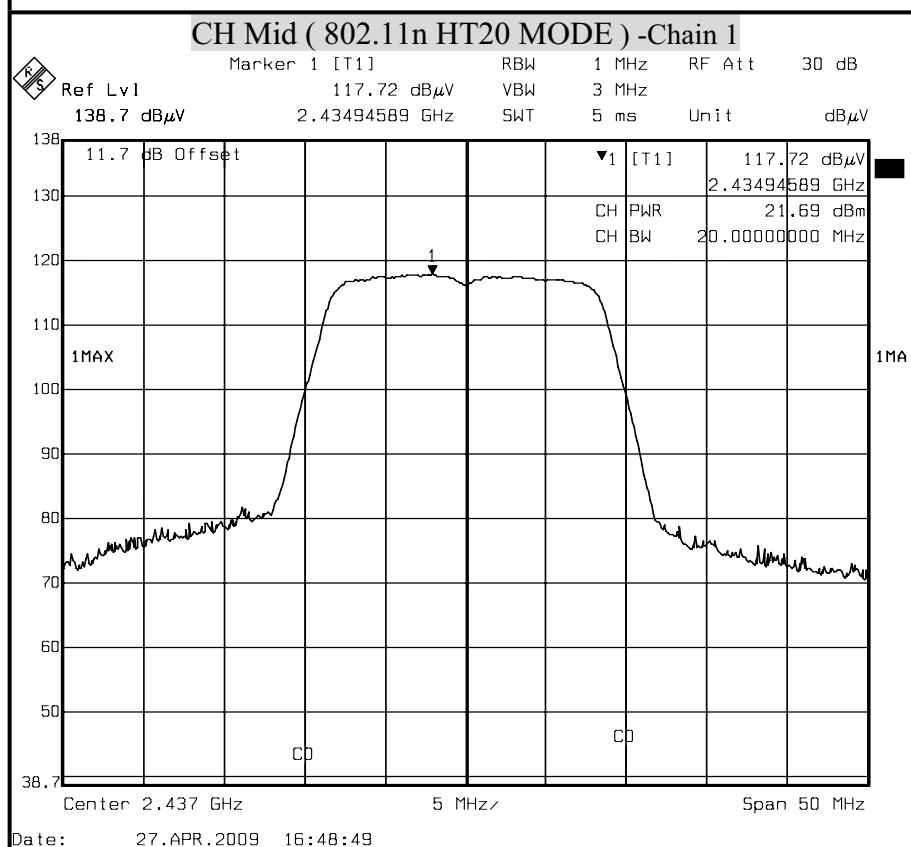
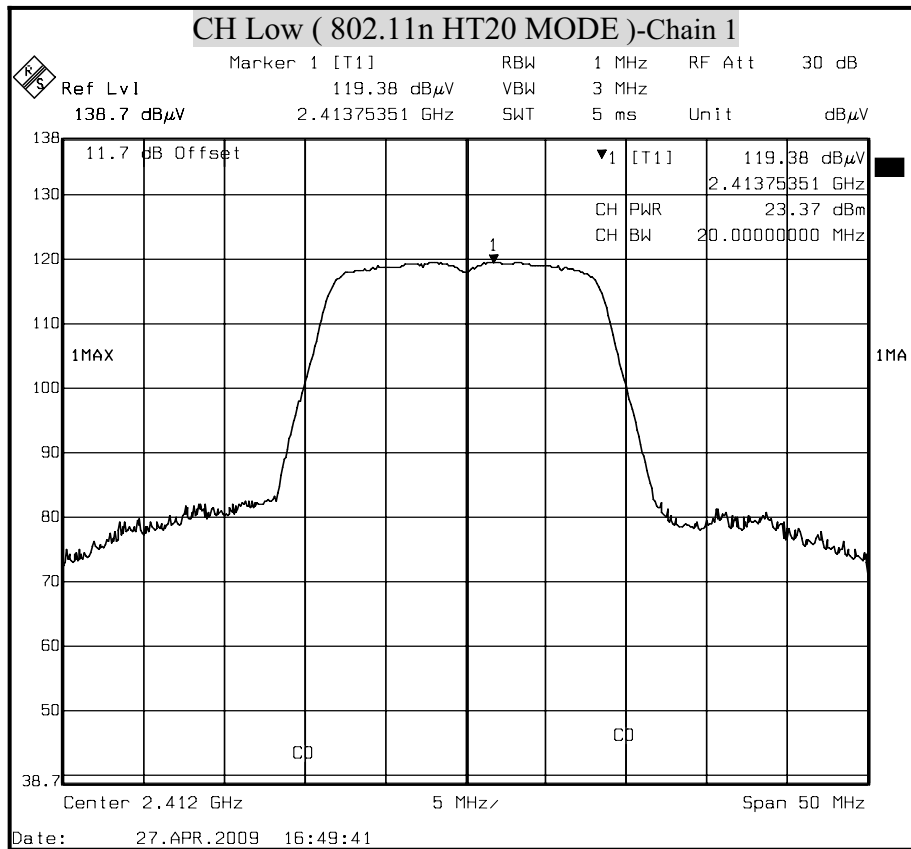

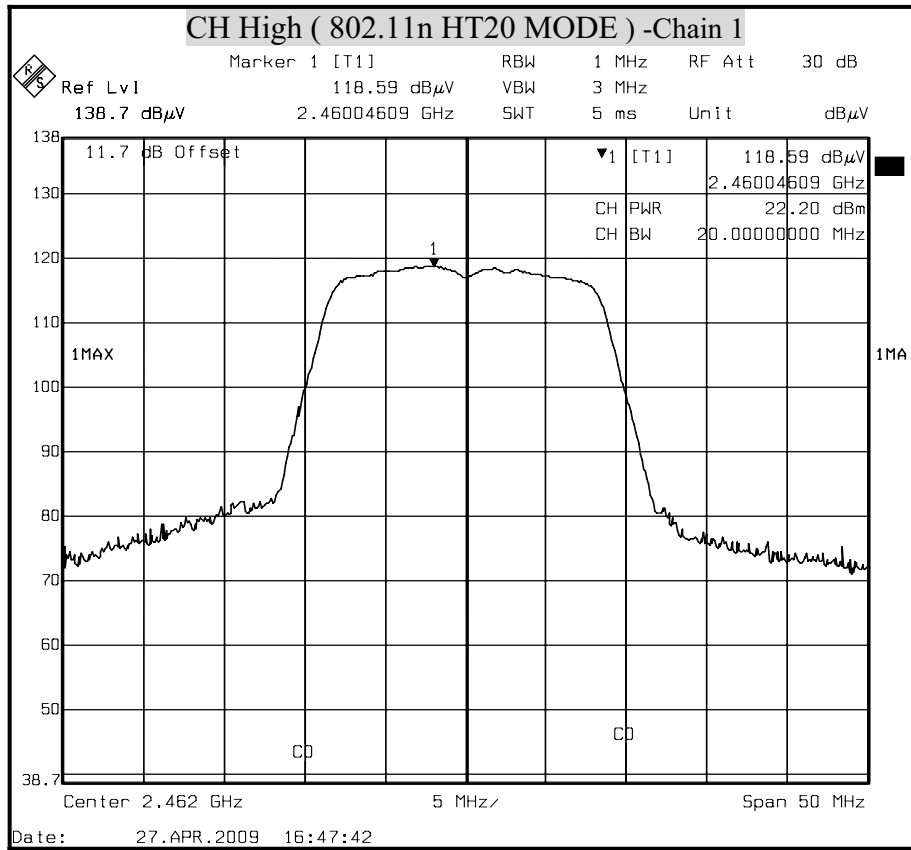



MAXIMUM PEAK OUTPUT POWER (802.11n HT40 MODE) Chain 0

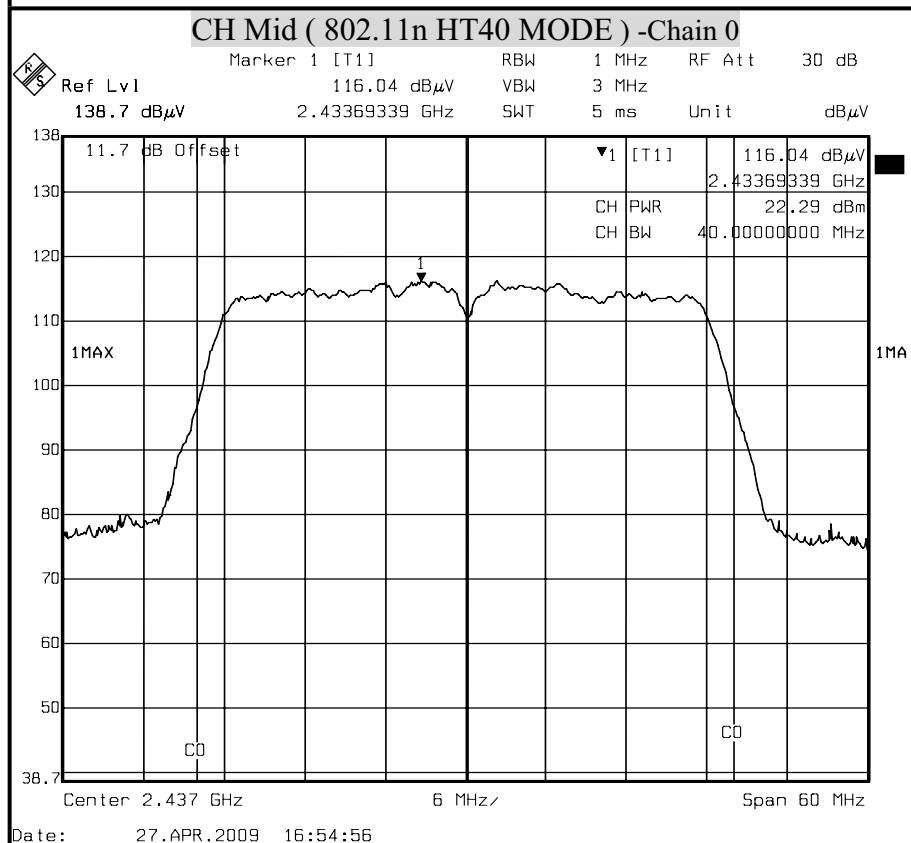
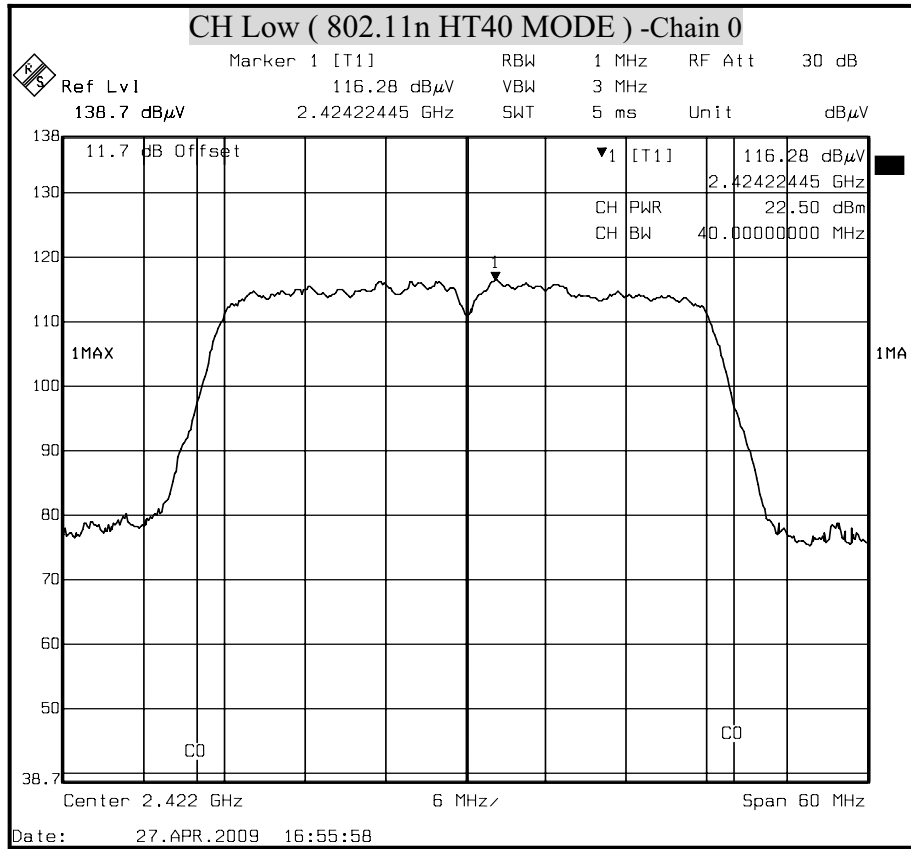

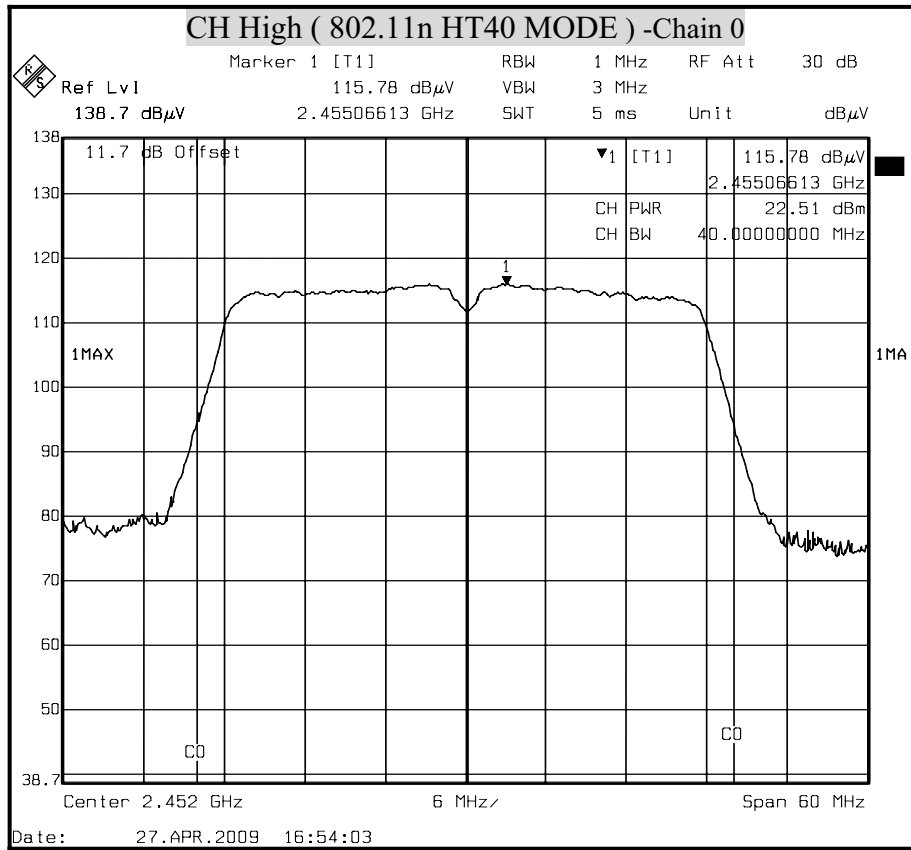



MAXIMUM PEAK OUTPUT POWER (802.11n HT40 MODE) Chain 1

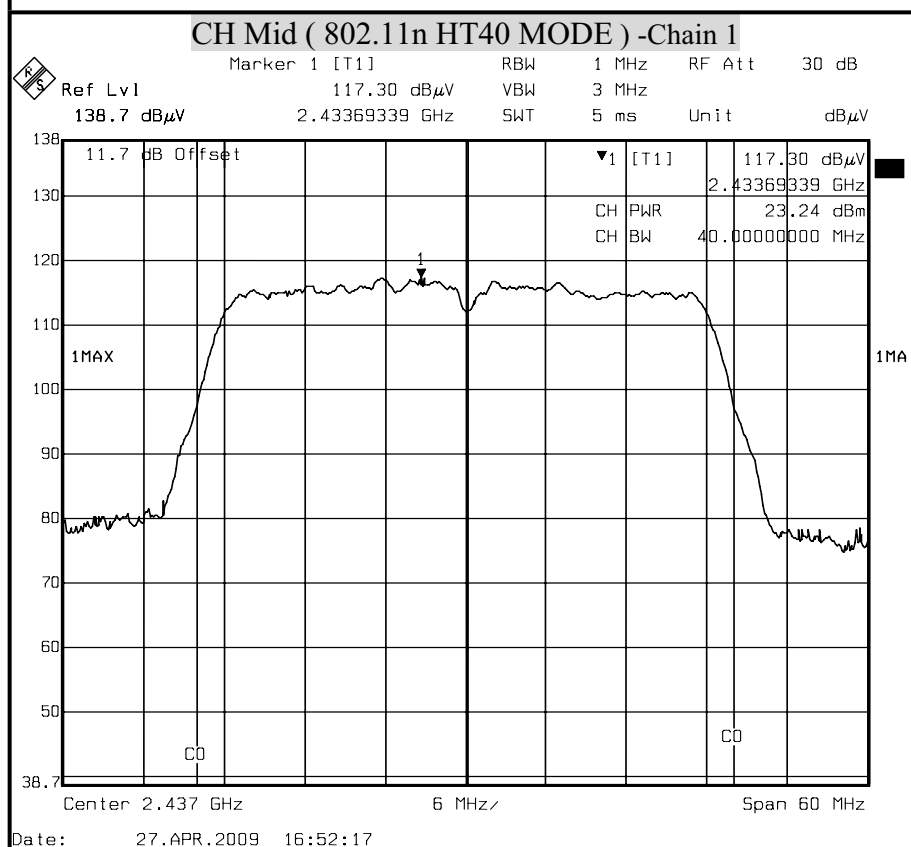
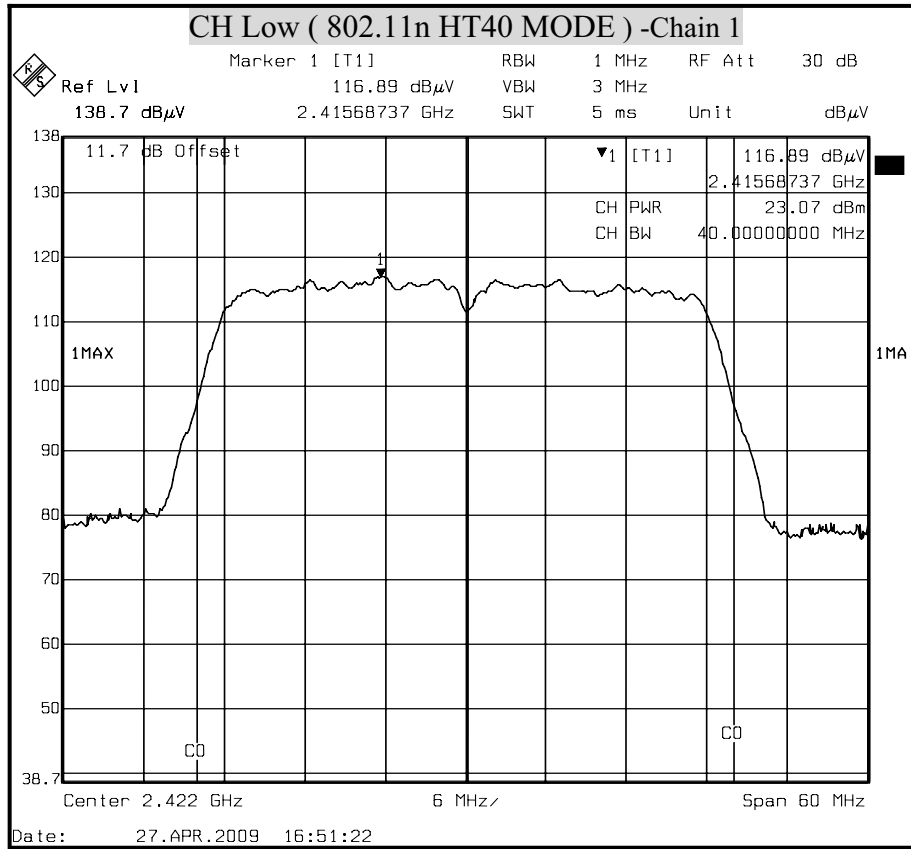

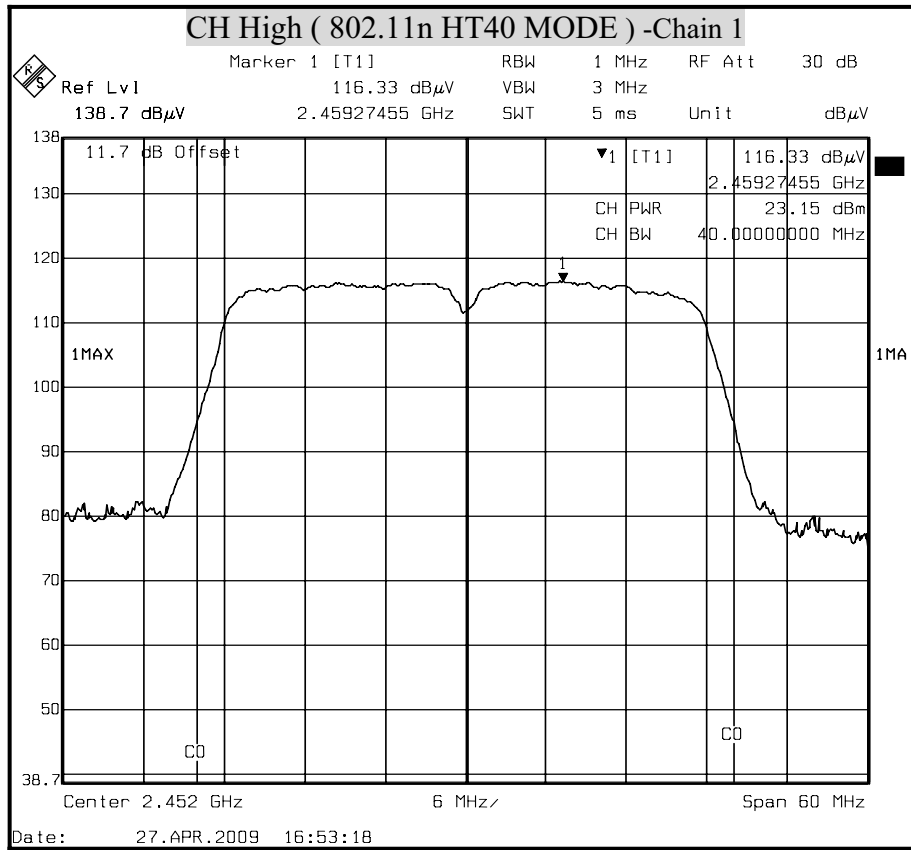

8.3 MAXIMUM PERMISSIBLE EXPOSURE

According to FCC 1.1310 : The criteria listed in the following table shall be used to evaluate the environment impact of human exposure to radio frequency (RF) radiation as specified in 1.1307(b) LIMITS FOR MAXIMUM PERMISSIBLE EXPOSURE (MPE)

Frequency Range (MHz)	Electric Field Strength (V/m)	Magnetic Field Strength (A/m)	Power Density (mW/cm ²)	Average Time
(A) Limits for Occupational / Control Exposures				
300-1,500	--	--	F/300	6
1,500-100,000	--	--	5	6
(B) Limits for General Population / Uncontrol Exposures				
300-1,500	--	--	F/1500	6
1,500-100,000	--	--	1	30

CALCULATIONS

Given $E = \frac{\sqrt{30 \times P \times G}}{d}$ & $S = \frac{E^2}{3770}$

Where E = Field strength in Volts / meter

P = Power in Watts

G = Numeric antenna gain

d = Distance in meters

S = Power density in milliwatts / square centimeter

Combining equations and re-arranging the terms to express the distance as a function of the remaining variables yields:

$$S = \frac{30 \times P \times G}{3770 d^2}$$

Changing to units of mW and cm, using:

$$P (mW) = P (W) / 1000 \text{ and}$$

$$d (cm) = d(m) / 100$$

Yields

$$S = \frac{30 \times (P/1000) \times G}{3770 \times (d/100)^2} = 0.0796 \times \frac{P \times G}{d^2}$$

Where d = Distance in cm

P = Power in mW

G = Numeric antenna gain

S = Power density in mW / cm²

**LIMIT**Power Density Limit, $S=1.0\text{mW}/\text{cm}^2$ **TEST RESULTS**

No non-compliance noted.

$$S = \frac{30 \times (P/1000) \times G}{3770 \times (d/100)^2} = 0.0796 \times \frac{P \times G}{d^2}$$

 $G=3.07\text{dBi}=2.02768272 \text{ dB}$ IEEE 80211b = $0.0796 \times 400.8667 \times 2.0276827 / 400 = 0.1617533$ IEEE 80211g = $0.0796 \times 220.8005 \times 2.0276827 / 400 = 0.0890949$ IEEE 802n HT20= $0.0796 \times 453.8621 \times 2.0276827 / 400 = 0.1831374$ IEEE 802n HT40= $0.0796 \times 384.7759 \times 2.0276827 / 400 = 0.1552605$

Mode	Minimum separation distance (cm)	Output Power (dBm)	Output Power (mw)	Antenna Gain (dBi)	Power Density Limit (mW/cm^2)	Power Density at 20cm (mW/cm^2)
IEEE 802.11b	20.0	26.03	400.867	3.07	1	0.1617533
IEEE 802.11g	20.0	23.44	220.8	3.07	1	0.0890949
IEEE 802.11n HT20	20.0	26.57	453.862	3.07	1	0.1831374
IEEE 802.11n HT40	20.0	25.85	384.776	3.07	1	0.1552605

REMARK: For mobile or fixed location transmitters, the maximum power density is $1.0 \text{ mW}/\text{cm}^2$ even if the calculation indicates that the power density would be larger.

8.4 POWER SPECTRAL DENSITY

LIMIT

§ 15.247(e) For digitally modulated systems, the power spectral density conducted from the intentional radiator to the antenna shall not greater than 8 dBm in any 3 kHz band during any time interval of continuous transmission.

TEST EQUIPMENTS

Name of Equipment	Manufacturer	Model	Serial Number	Calibration Due
Spectrum Analyzer	R&S	FSEK 30	835253/002	OCT. 14, 2009

TEST SETUP

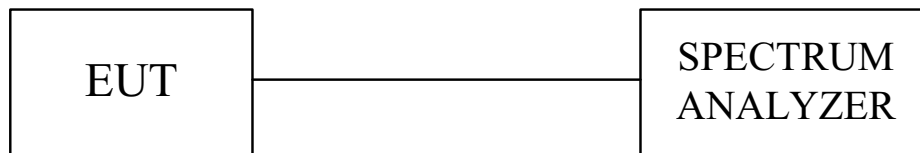

TEST PROCEDURE

The transmitter output was connected to the spectrum analyzer, the bandwidth of the fundamental frequency was measured with the spectrum analyzer using RBW=3KHz and VBW ≥ RBW, set sweep time=span / 3KHz.

The power spectral density was measured and recorded.

The sweep time is allowed to be longer than span / 3KHz for a full response of the mixer in the spectrum analyzer.

TEST RESULTS

Total peak power density calculation formula:

$$10 \log (10^{\text{Chain 0 PPSD} / 10} + 10^{\text{Chain1 PPSD} / 10}).$$

No non-compliance noted

**IEEE 802.11b mode**

Channel	Channel Frequency (MHz)	Final RF Power Level in 3KHz BW (dBm)	Maximum Limit (dBm)	Pass / Fail
Low	2412	-4.37	8	PASS
Middle	2437	-4.21	8	PASS
High	2462	-3.89	8	PASS

NOTE : 1. At final test to get the worst-case emission at 11Mbps.
2. The cable assembly insertion loss of 11.7dB (including 10 dB pad and 1.7 dB cable) was Entered as an offset in the spectrum analyzer to allow for direct reading of power.

IEEE 802.11g mode

Channel	Channel Frequency (MHz)	Final RF Power Level in 3KHz BW (dBm)	Maximum Limit (dBm)	Pass / Fail
Low	2412	-12.89	8	PASS
Middle	2437	-12.63	8	PASS
High	2462	-12.12	8	PASS

NOTE : 1. At final test to get the worst-case emission at 6Mbps.
2. The cable assembly insertion loss of 11.7dB (including 10 dB pad and 1.7 dB cable) was Entered as an offset in the spectrum analyzer to allow for direct reading of power.

IEEE 802.11n HT20 mode

Channel	Channel Frequency (MHz)	Final RF Power Level in 3KHz BW Chain 0 (dBm)	Final RF Power Level in 3KHz BW Chain 1 (dBm)	PPSD Total (dBm)	Maximum Limit (dBm)	Pass / Fail
Low	2412	-12.17	-12.97	-9.54	8	PASS
Middle	2437	-15.75	-14.67	-12.17	8	PASS
High	2462	-13.02	-13.51	-10.25	8	PASS

NOTE : 1. At final test to get the worst-case emission at 13.5Mbps.
2. The cable assembly insertion loss of 11.7dB (including 10 dB pad and 1.7 dB cable) was Entered as an offset in the spectrum analyzer to allow for direct reading of power.

IEEE 802.11n HT20 Combined mode

Channel	Channel Frequency (MHz)	Final RF Power Level in 3KHz BW (dBm)	Maximum Limit (dBm)	Pass / Fail
Low	2412	-9.43	8	PASS
Middle	2437	-9.86	8	PASS
High	2462	-9.85	8	PASS

Note : 1. At final test to get the worst-case emission at 13.5Mbps.
2. The cable assembly insertion loss of 15.2dB (including 10 dB pad and 5.2 dB cable) was Entered as an offset in the spectrum analyzer to allow for direct reading of power.

**IEEE 802.11n HT40 mode**

Channel	Channel Frequency (MHz)	Final RF Power Level in 3KHz BW Chain 0 (dBm)	Final RF Power Level in 3KHz BW Chain 1 (dBm)	PPSD Total (dBm)	Maximum Limit (dBm)	Pass / Fail
Low	2422	-17.36	-17.43	-14.38	8	PASS
Middle	2437	-17.49	-16.23	-13.80	8	PASS
High	2452	-14.37	-17.94	-12.79	8	PASS

- NOTE :**
1. At final test to get the worst-case emission at 13.5Mbps.
 2. The cable assembly insertion loss of 11.7dB (including 10 dB pad and 1.7 dB cable) was Entered as an offset in the spectrum analyzer to allow for direct reading of power.

IEEE 802.11n HT40 Combined mode

Channel	Channel Frequency (MHz)	Final RF Power Level in 3KHz BW (dBm)	Maximum Limit (dBm)	Pass / Fail
Low	2422	-13.77	8	PASS
Middle	2437	-11.59	8	PASS
High	2452	-12.39	8	PASS

- Note :**
1. At final test to get the worst-case emission at 13.5Mbps.
 2. The cable assembly insertion loss of 15.2dB (including 10 dB pad and 5.2 dB cable) was Entered as an offset in the spectrum analyzer to allow for direct reading of power.



POWER SPECTRAL DENSITY (IEEE 802.11b MODE)

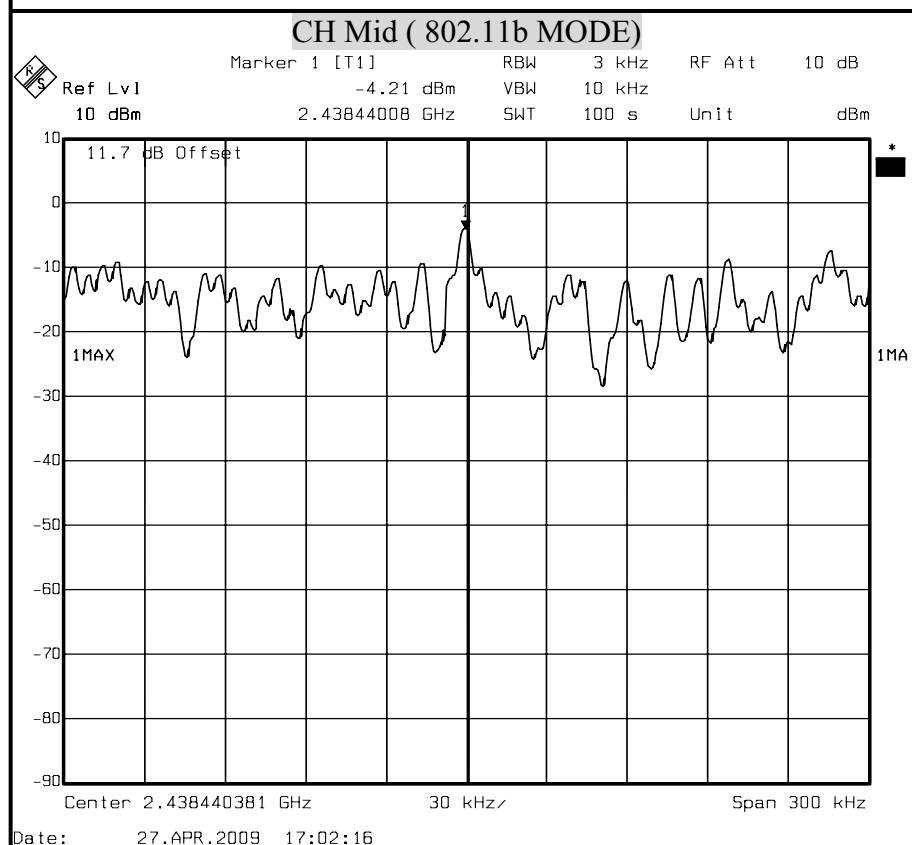
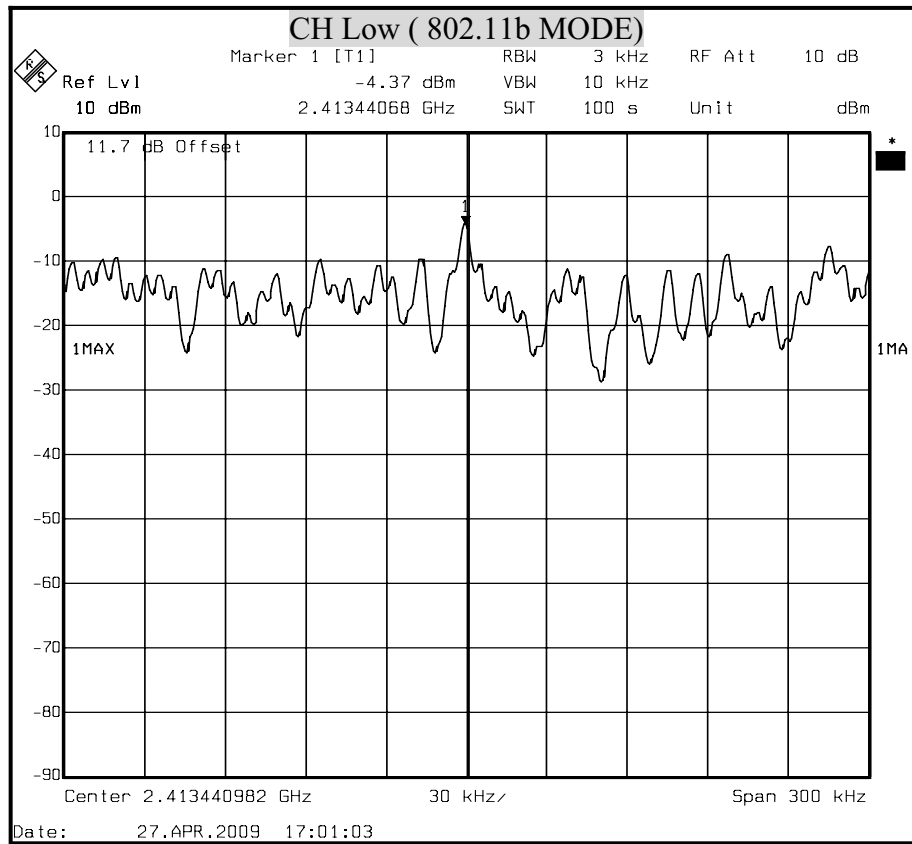

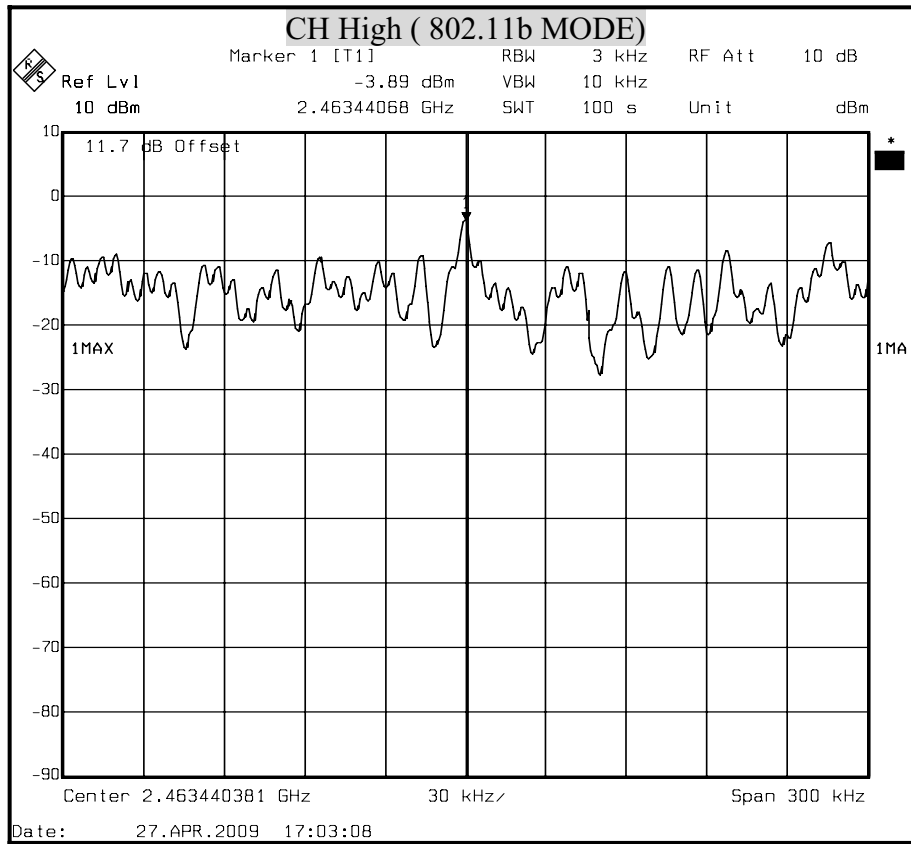



POWER SPECTRAL DENSITY (IEEE 802.11g MODE)

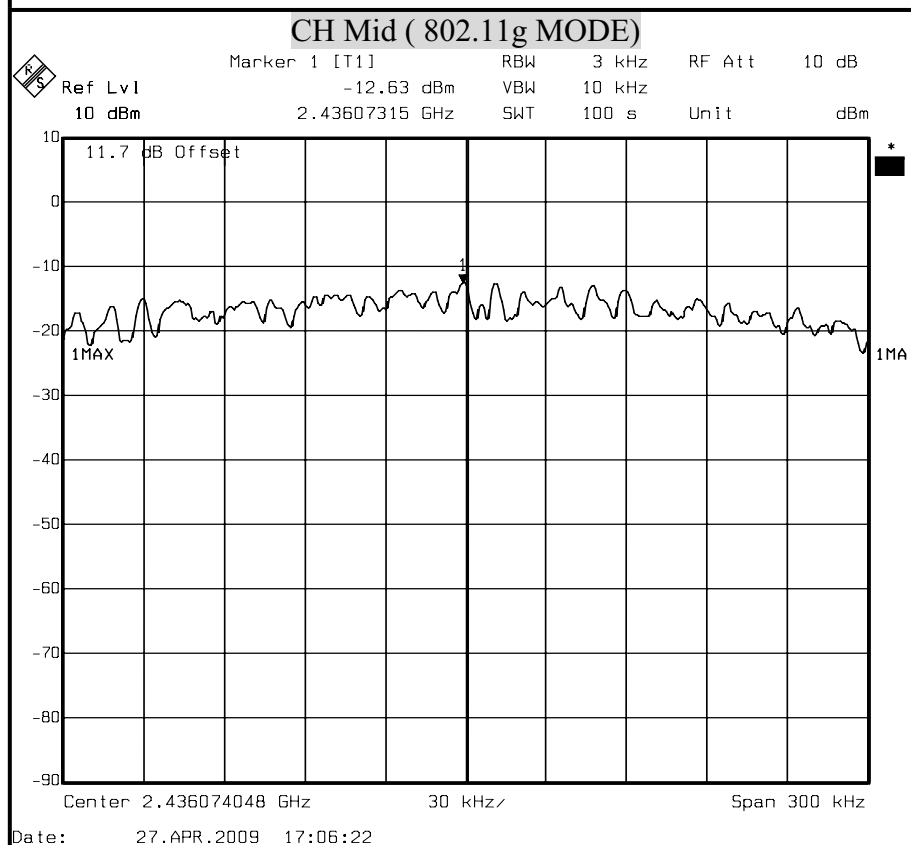
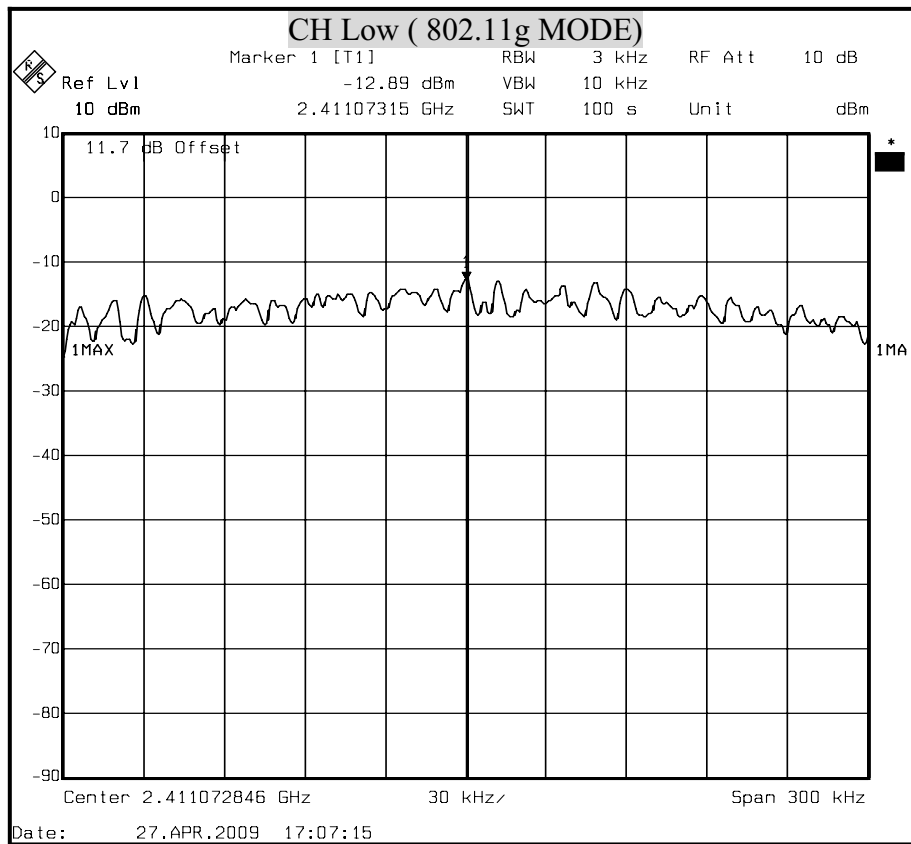

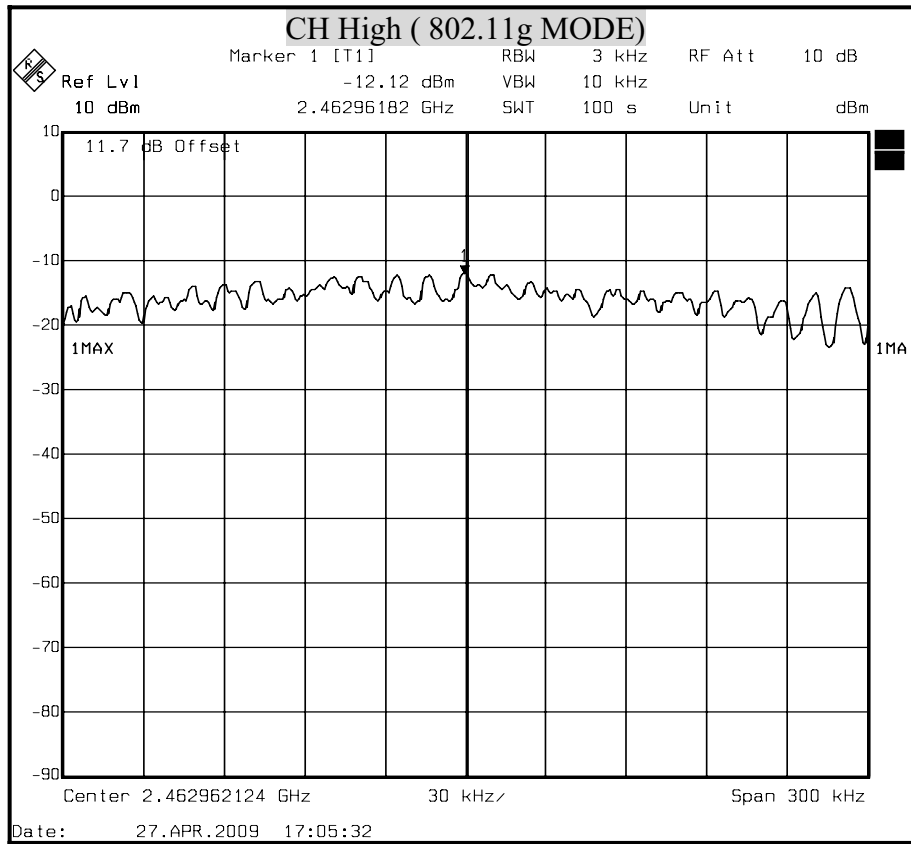



POWER SPECTRAL DENSITY (802.11n HT20 MODE) Chain 0

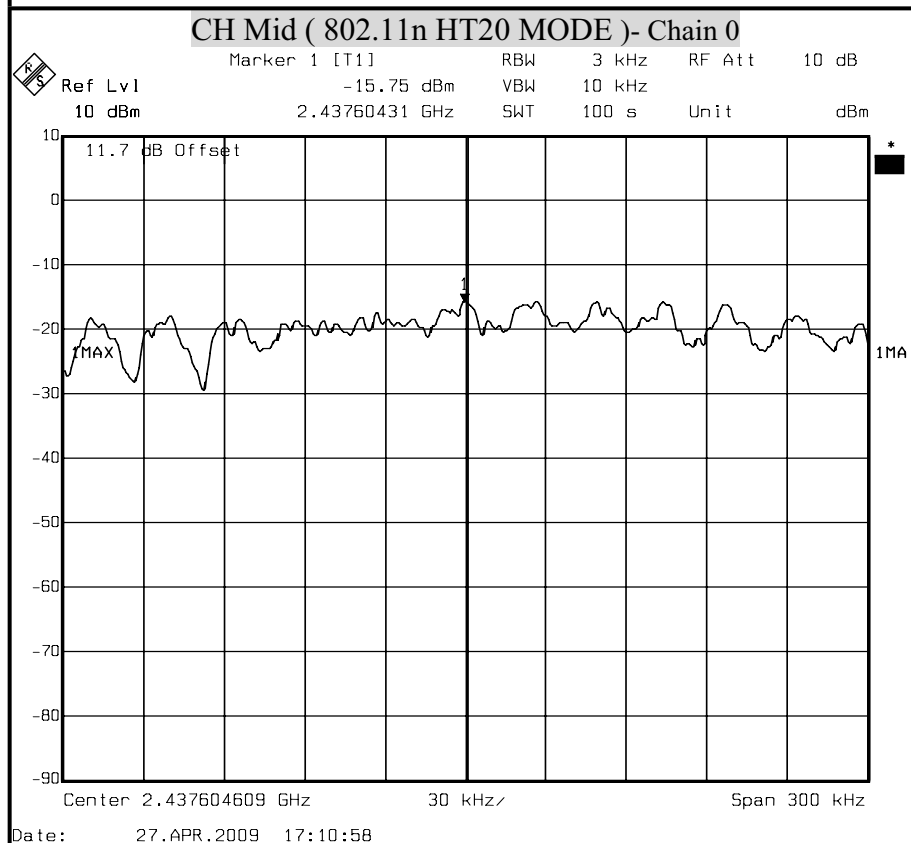
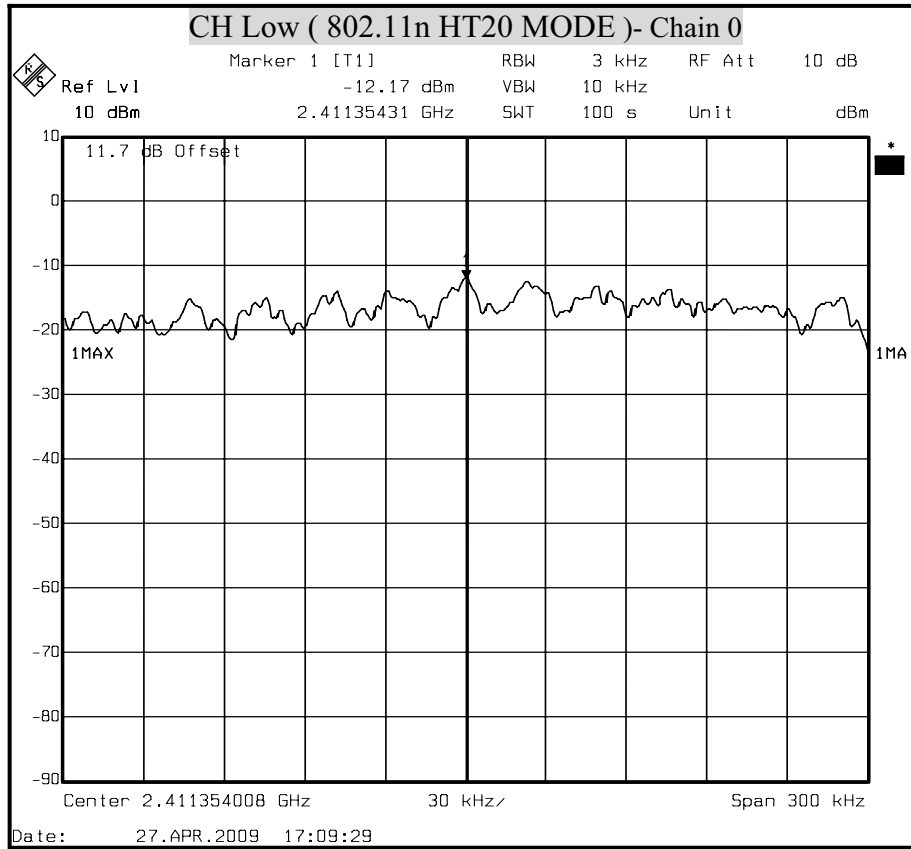

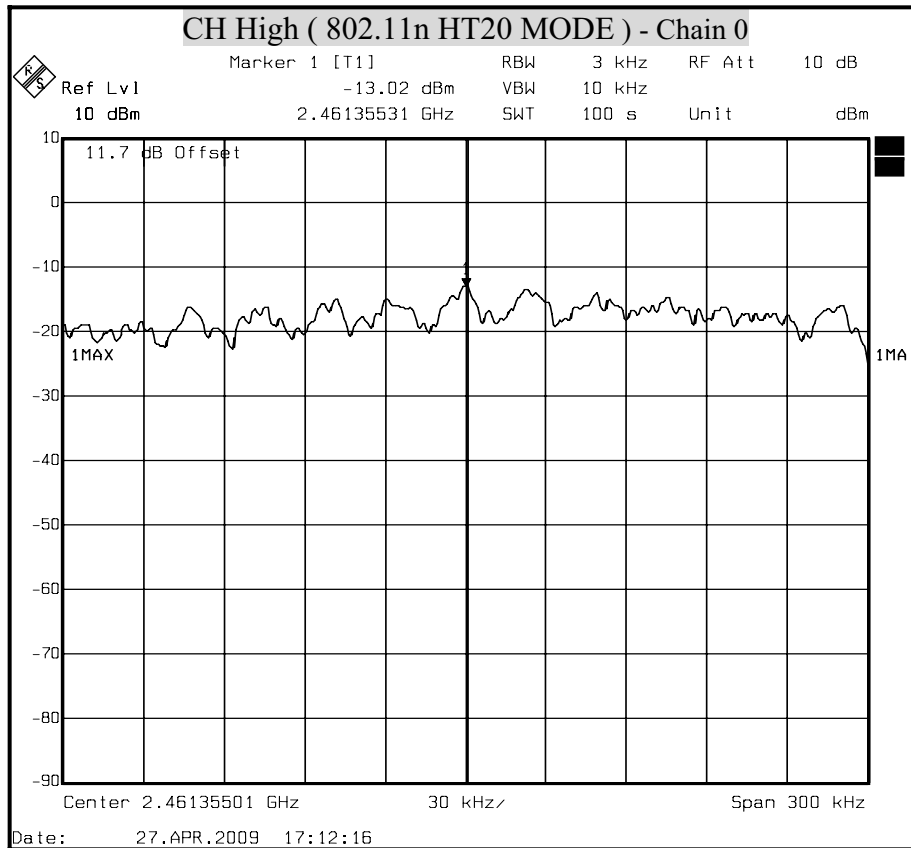



POWER SPECTRAL DENSITY (802.11n HT20 MODE) Chain 1

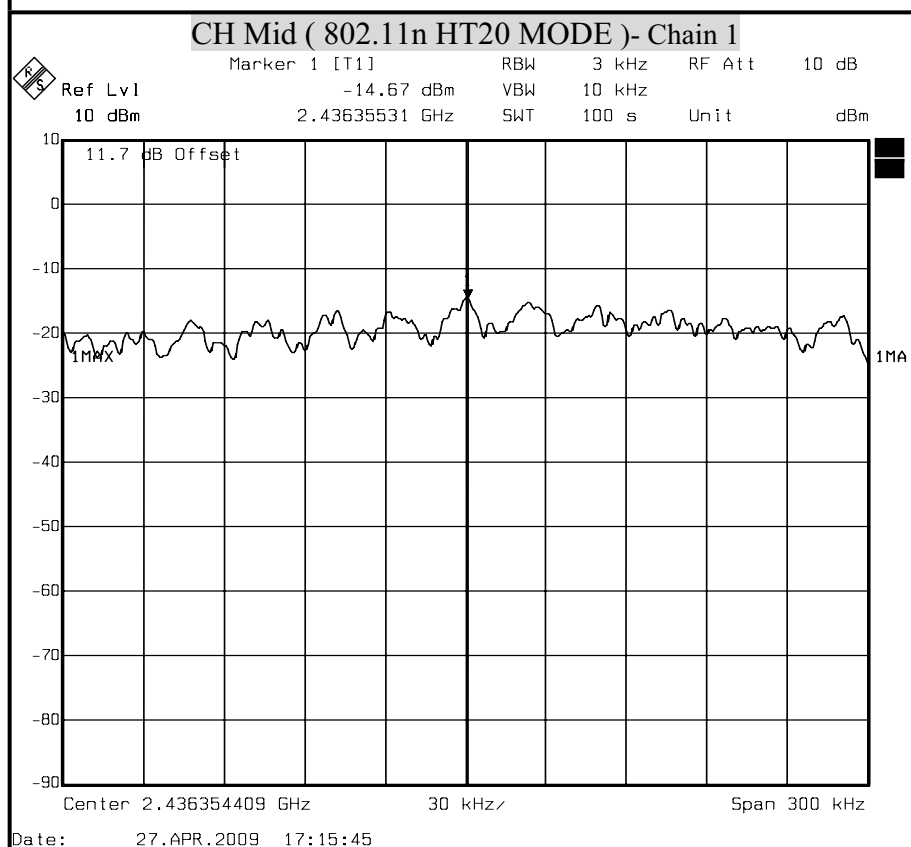
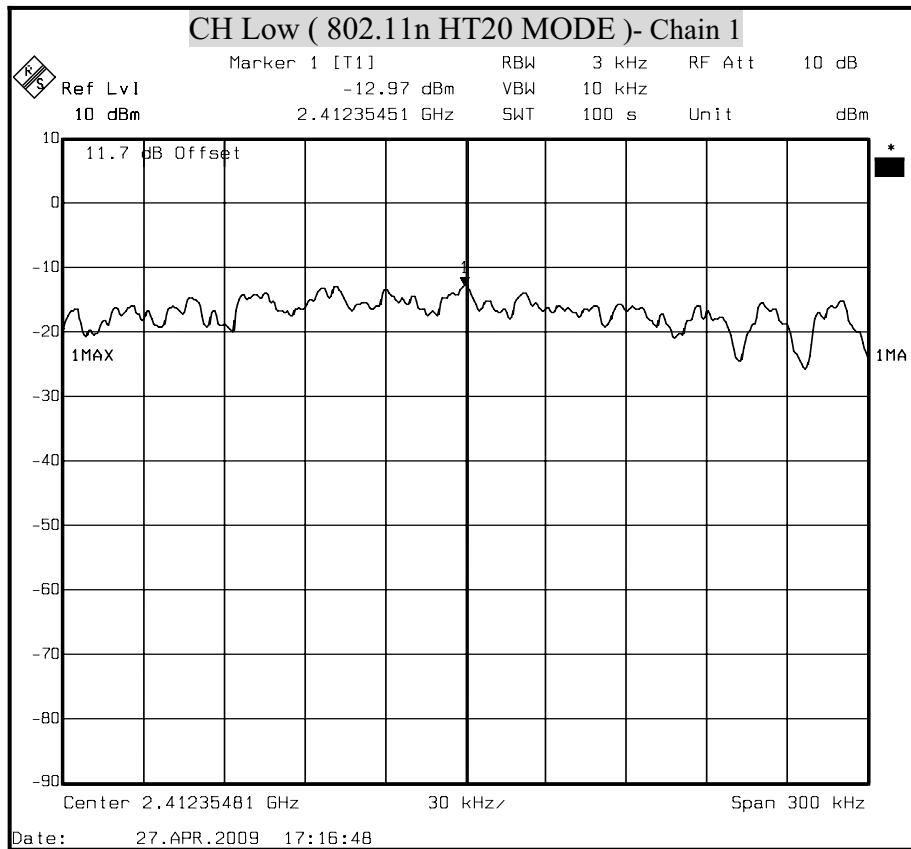

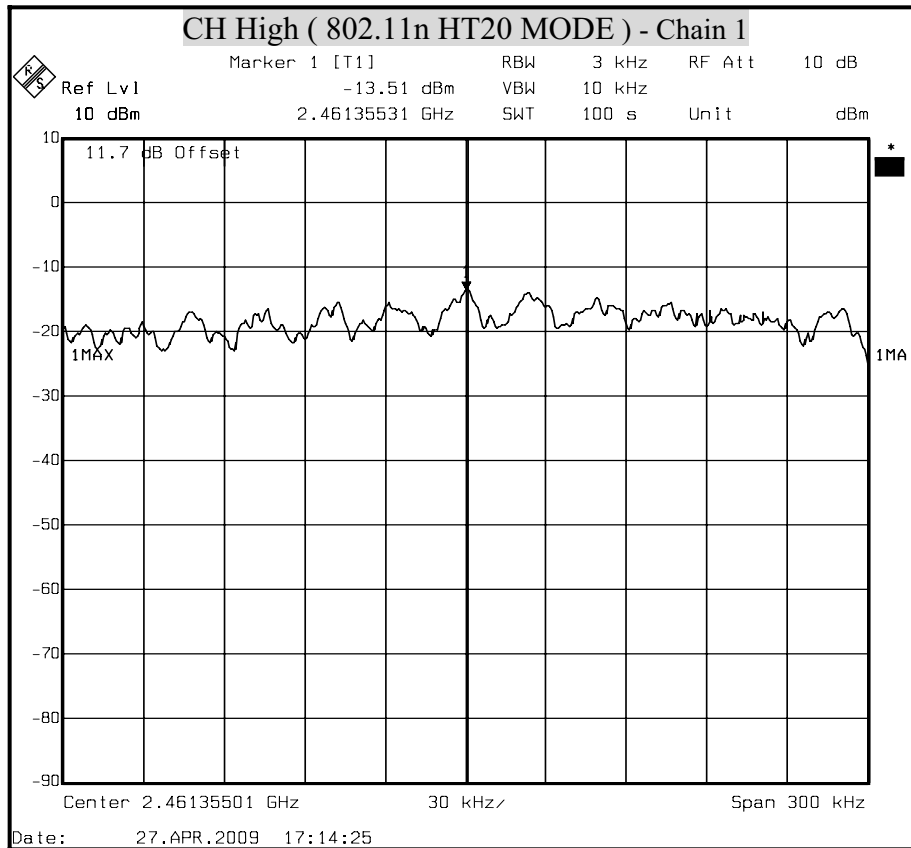



POWER SPECTRAL DENSITY (802.11n HT20 MODE) Combined

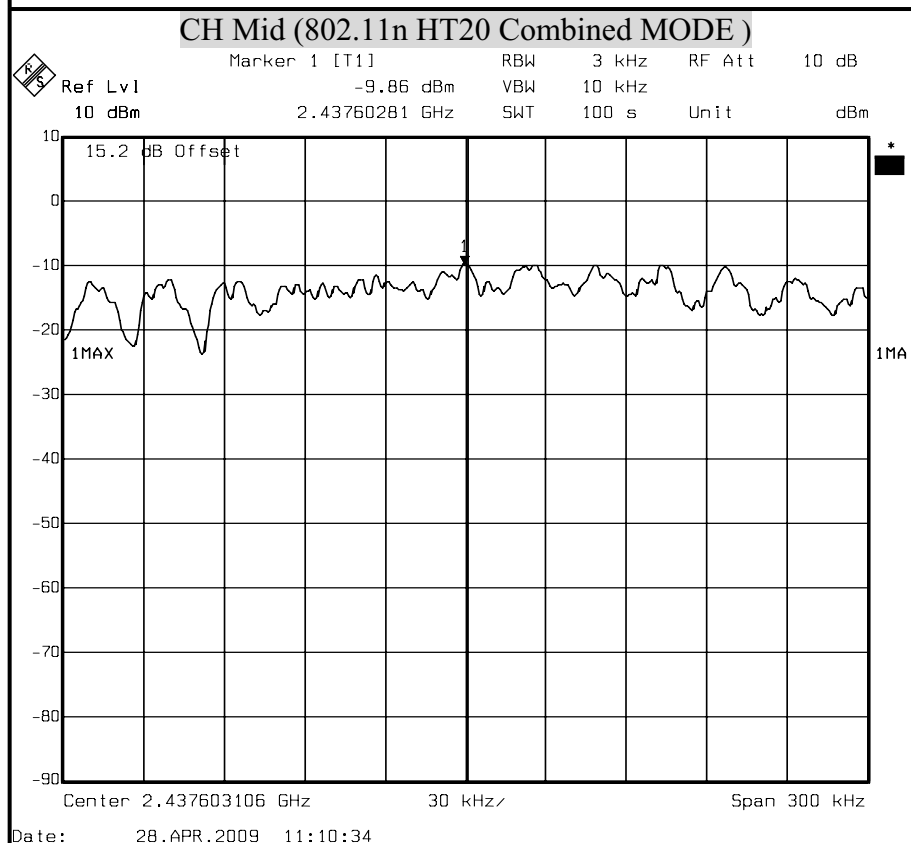
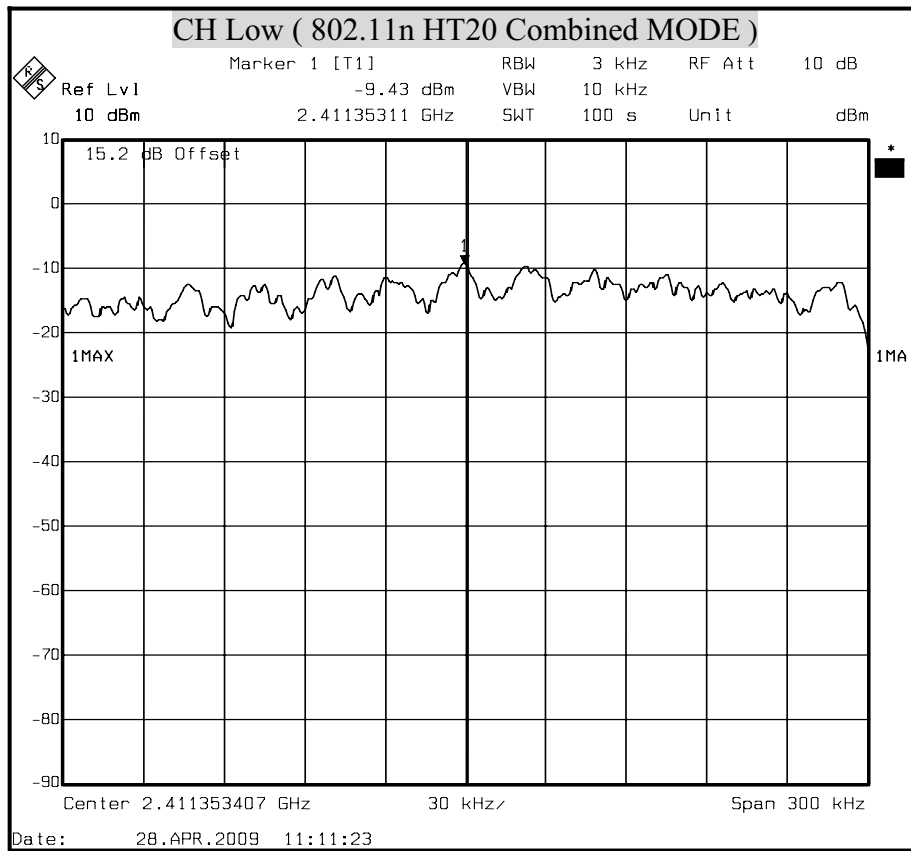

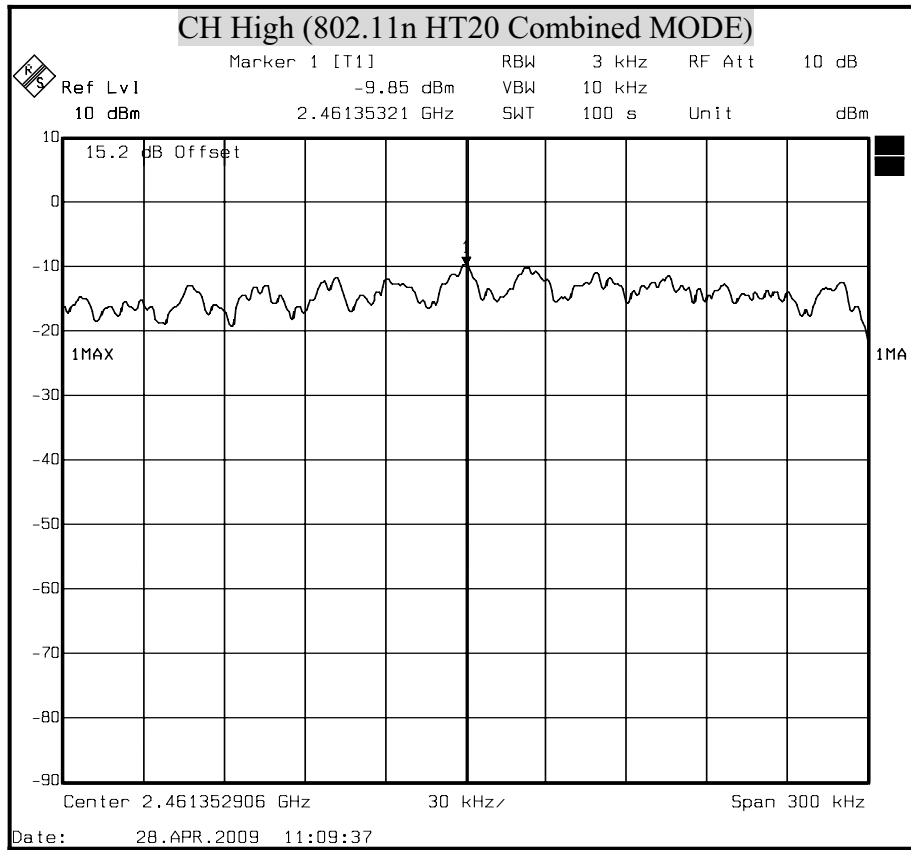



POWER SPECTRAL DENSITY (802.11n HT40 MODE) Chain 0

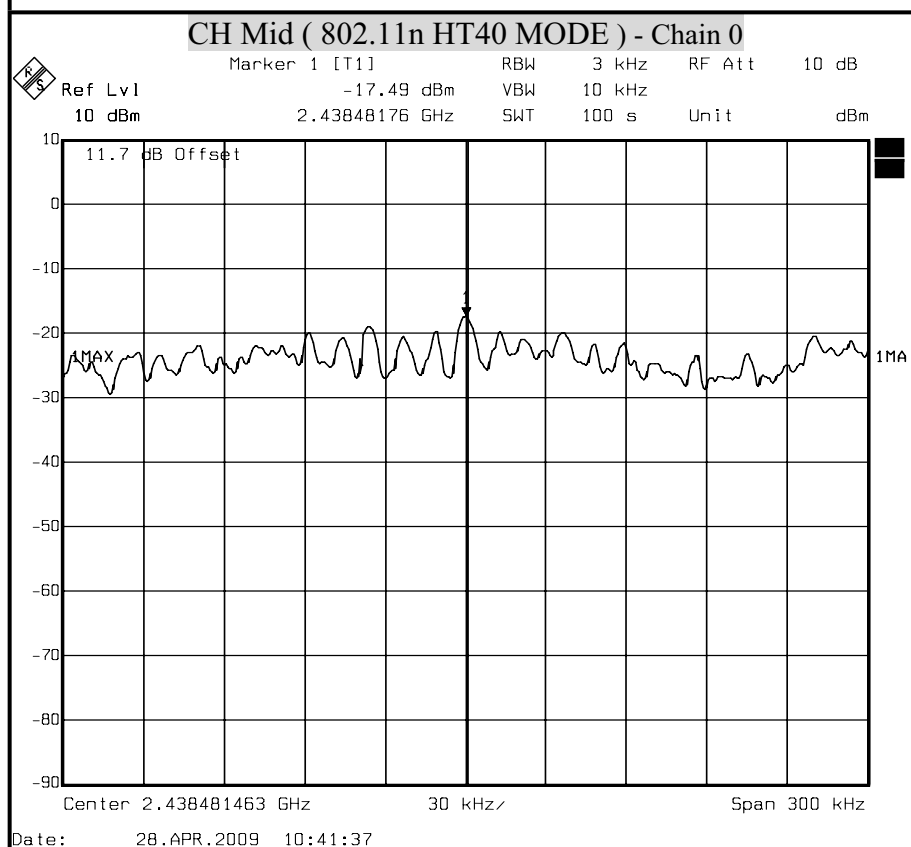
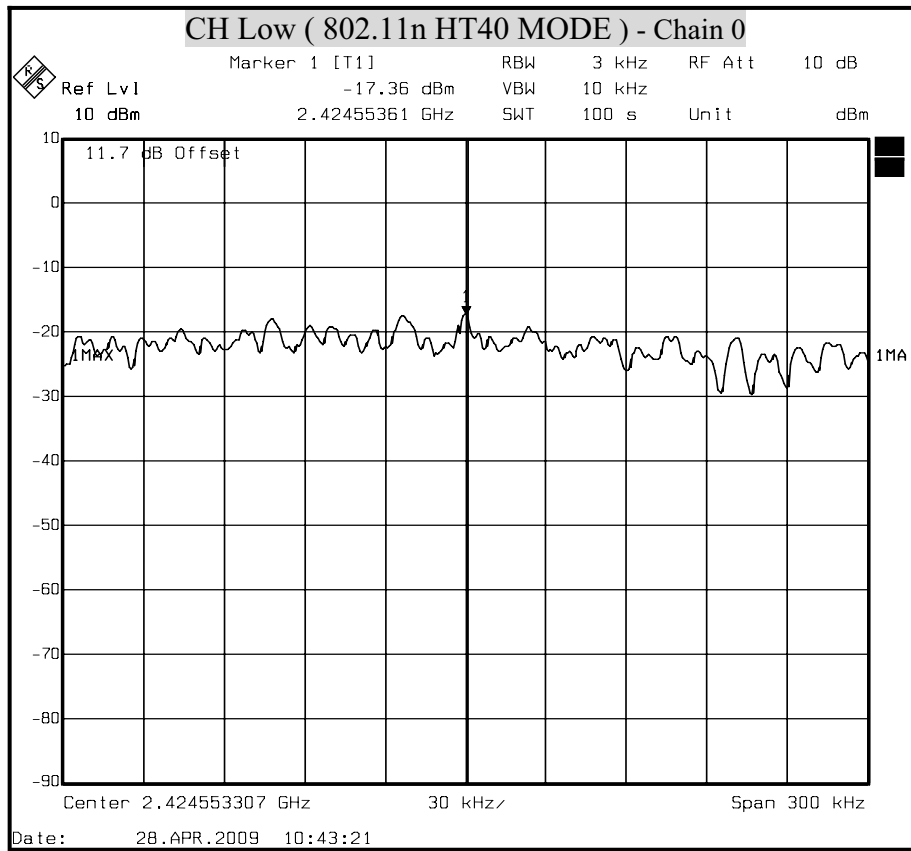

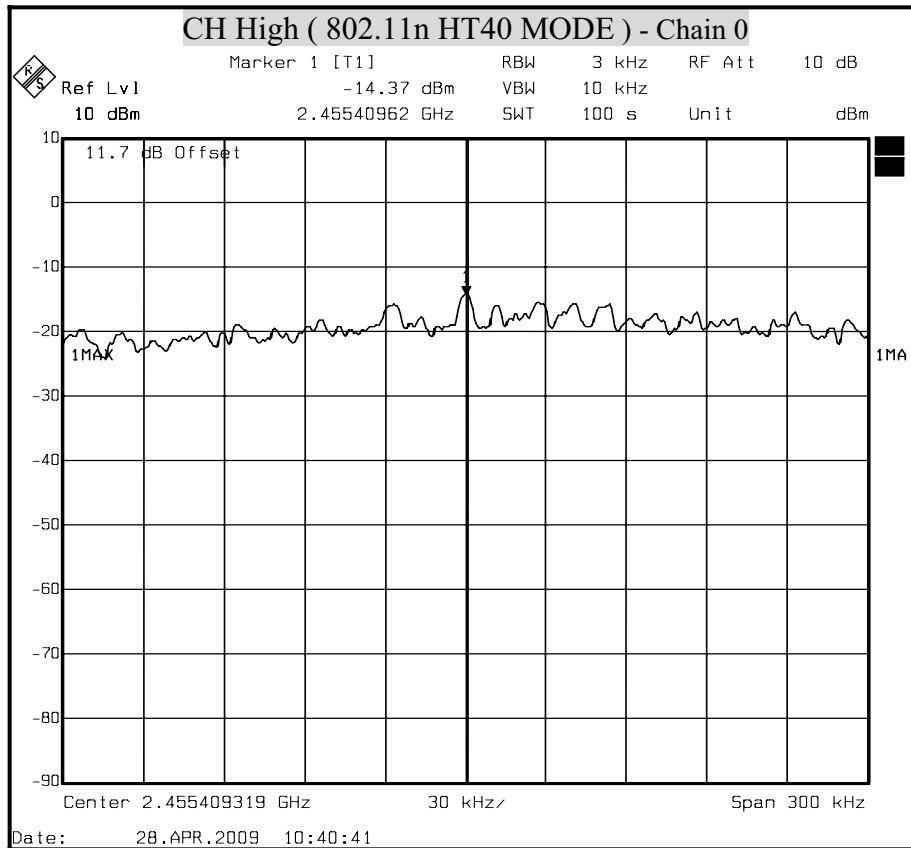



POWER SPECTRAL DENSITY (802.11n HT40 MODE) Chain 1

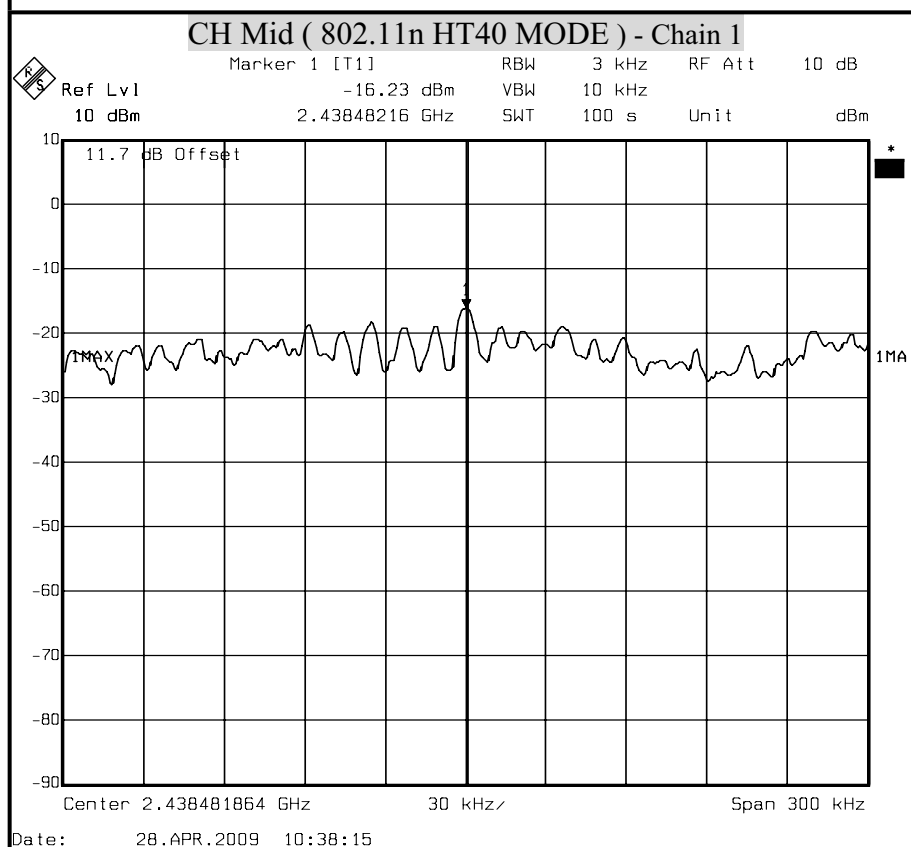
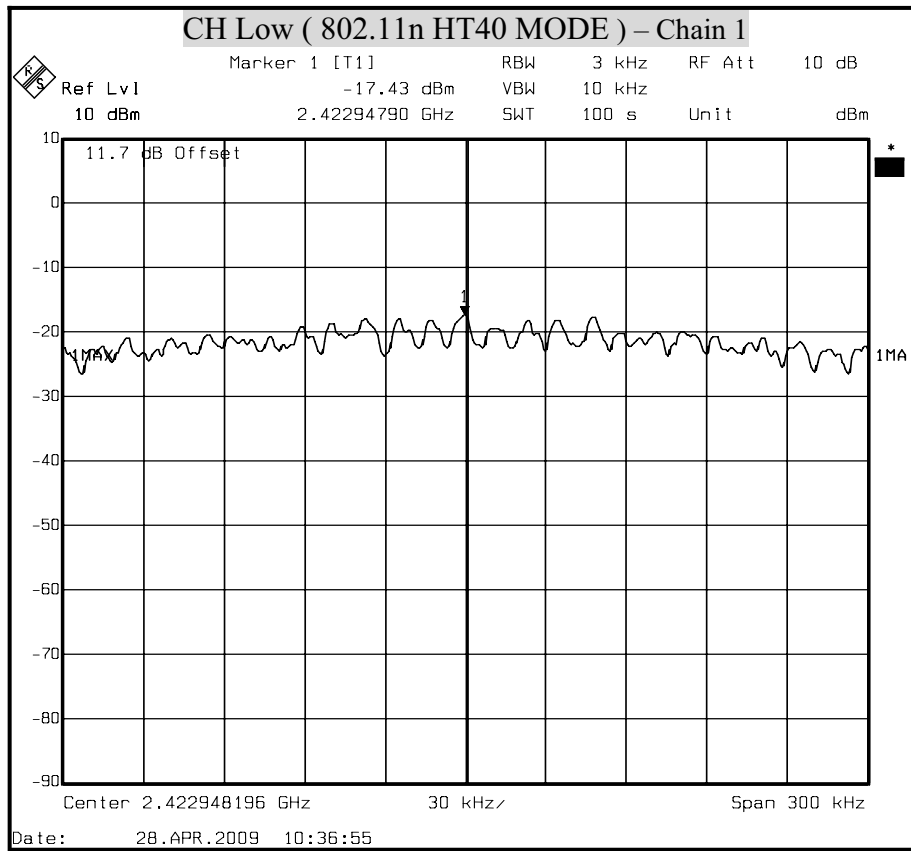

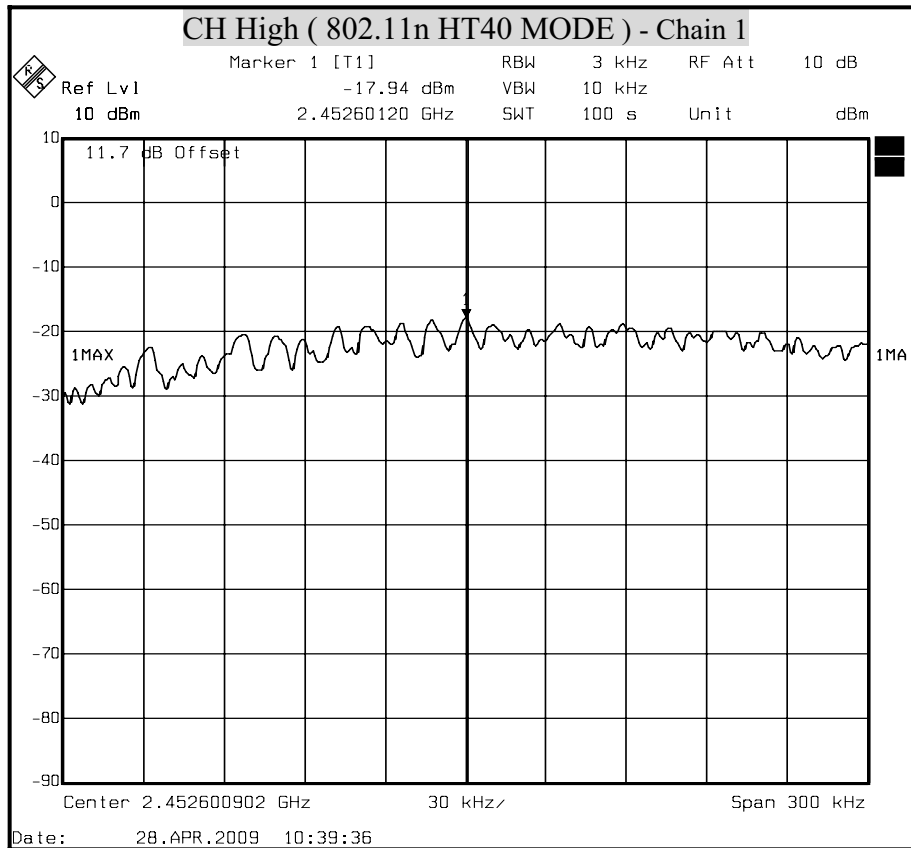



POWER SPECTRAL DENSITY (802.11n HT40 MODE) Combined

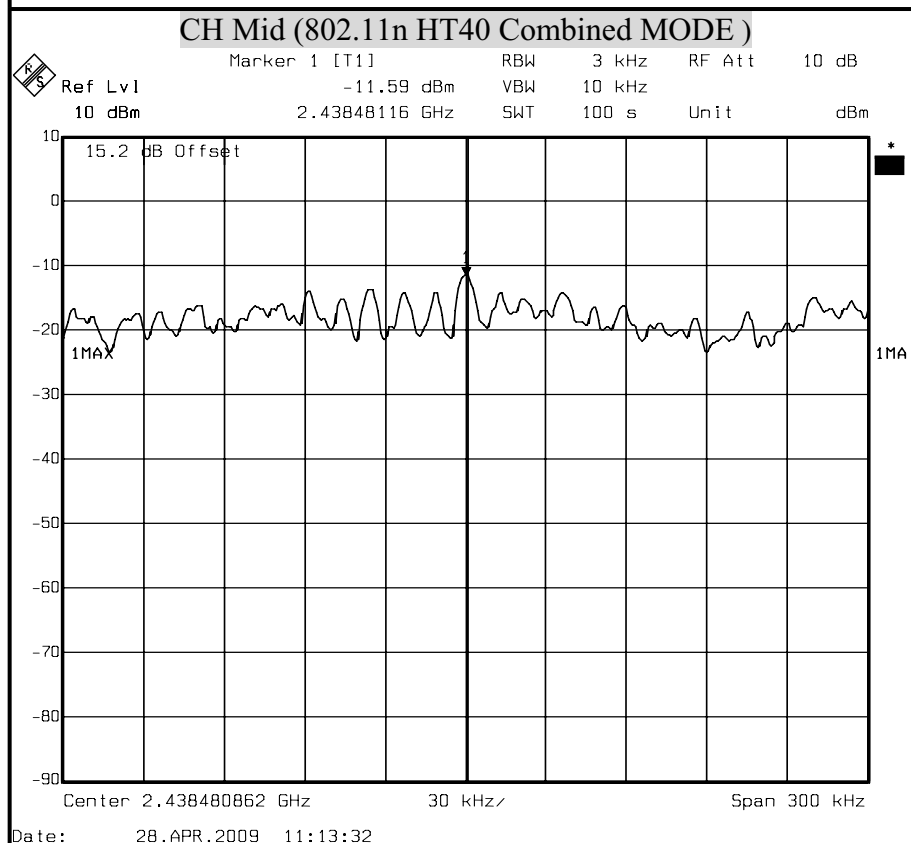
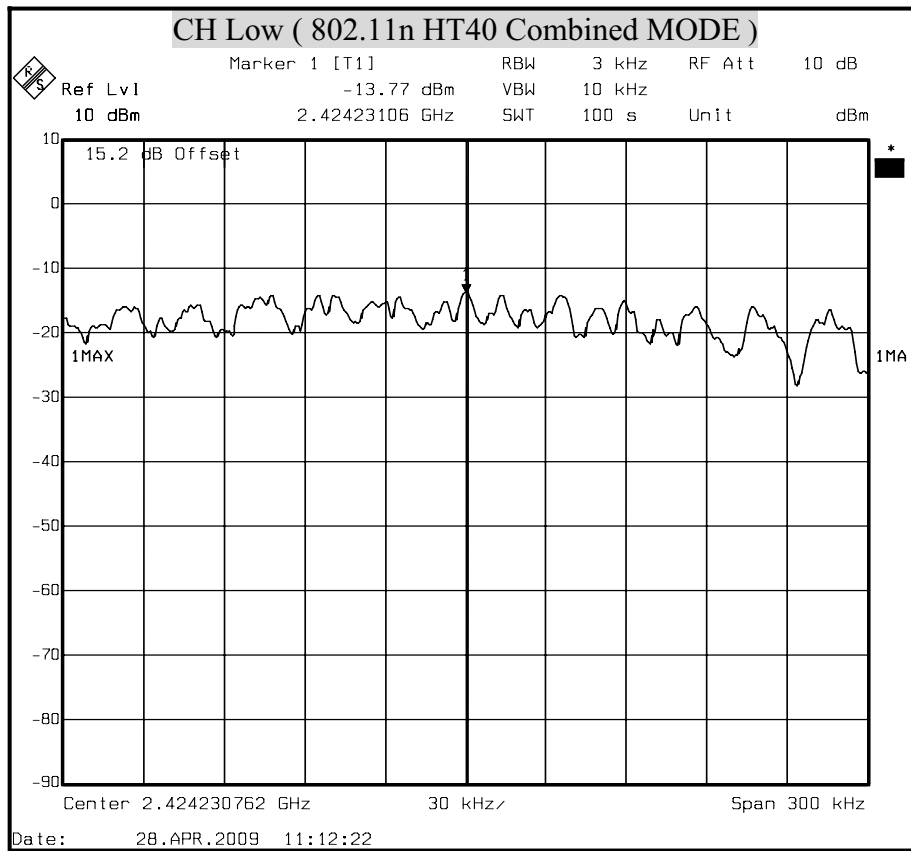

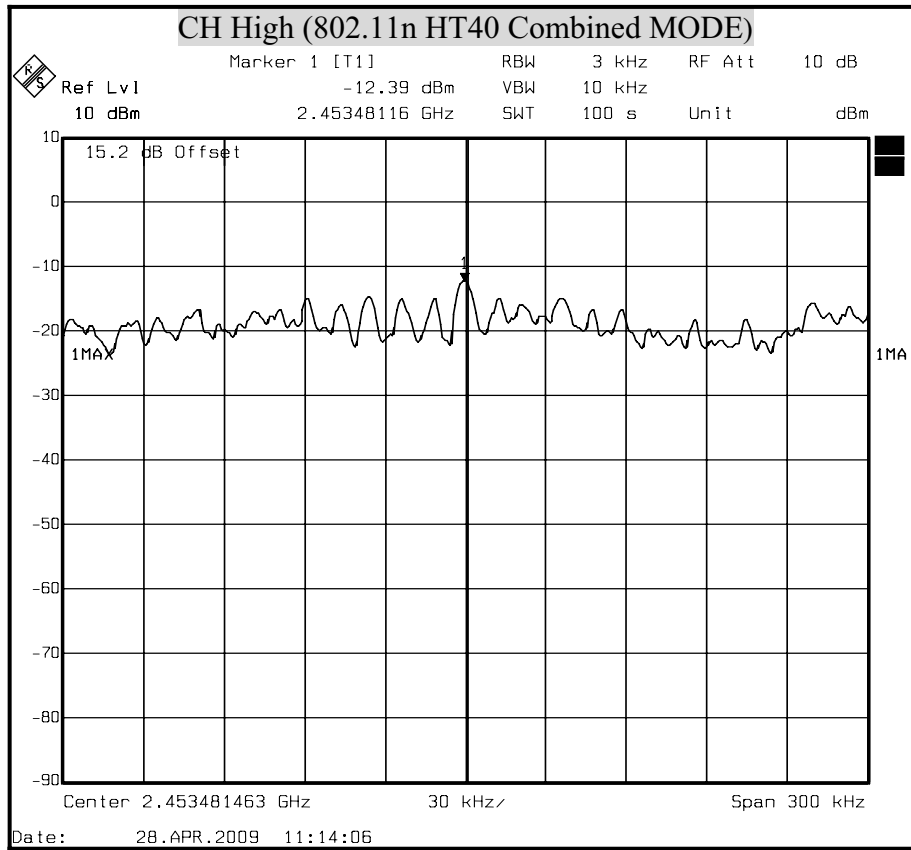

8.5 CONDUCTED SPURIOUS EMISSION

LIMITS

§ 15.247(d) In any 100 kHz bandwidth outside the frequency band in which the spread spectrum intentional radiator is operating, the radio frequency power that is produced by the intentional radiator shall be at least 20 dB below that in the 100 kHz bandwidth within the band that contains the highest level of the desired power, based on either an RF conducted or a radiated measurement. Attenuation below the general limits specified in § 15.209(a) is not required. In addition, radiated emissions which fall in the restricted bands, as defined in § 15.205(a), must also comply with the radiated emission limits specified in § 15.209(a) (see § 15.205(c)).

TEST PROCEDURE

The transmitter output is connected to a spectrum analyzer. The resolution bandwidth is set to 100 kHz. The video bandwidth is set to 100 kHz.

The spectrum from 30 MHz to 26.5 GHz is investigated with the transmitter set to the lowest, middle, and highest channels in the 2.4 GHz band.

TEST SETUP

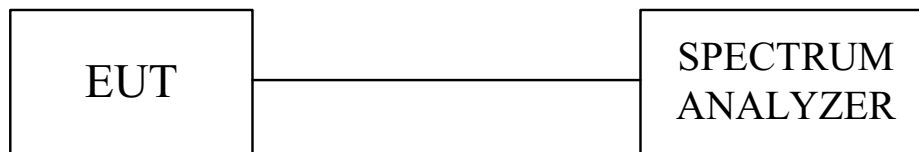

TEST RESULTS

No non-compliance noted.

**TEST DATA****IEEE 802.11b mode****Low**

Frequency	Offset	Reading	Level	Limit	Margin	Pass/Fail
(MHz)	(dB)	(dB μ V)	(dB μ V)	(dB μ V)	(dB)	
2412.5362	11.7	100.82	112.52	N/A	N/A	--
1780.521	11.7	39.83	51.53	92.52	-40.99	PASS
6607.7154	11.7	44.16	55.86	92.52	-36.66	PASS
6925.9919	11.7	44.6	56.3	92.52	-36.22	PASS

Mid

Frequency	Offset	Reading	Level	Limit	Margin	Pass/Fail
(MHz)	(dB)	(dB μ V)	(dB μ V)	(dB μ V)	(dB)	
2437.2564	11.7	102.28	113.98	N/A	N/A	--
1462.2444	11.7	40.25	51.95	93.98	-42.03	PASS
6607.7154	11.7	44.94	56.64	93.98	-37.34	PASS
6979.038	11.7	44.6	56.3	93.98	-37.68	PASS

High

Frequency	Offset	Reading	Level	Limit	Margin	Pass/Fail
(MHz)	(dB)	(dB μ V)	(dB μ V)	(dB μ V)	(dB)	
2462.1352	11.7	102.69	114.39	N/A	N/A	--
1833.5671	11.7	40.52	52.22	94.39	-42.17	PASS
6607.7154	11.7	44.86	56.56	94.39	-37.83	PASS
6925.9919	11.7	45.54	57.24	94.39	-37.15	PASS

**IEEE 802.11g mode****Low**

Frequency	Offset	Reading	Level	Limit	Margin	Pass/Fail
(MHz)	(dB)	(dB μ V)	(dB μ V)	(dB μ V)	(dB)	
2412.3542	11.7	95.43	107.13	N/A	N/A	--
1143.9679	11.7	41.67	53.37	87.13	-33.76	PASS
6660.7615	11.7	44.97	56.67	87.13	-30.46	PASS
6925.9919	11.7	44.71	56.41	87.13	-30.72	PASS

Mid

Frequency	Offset	Reading	Level	Limit	Margin	Pass/Fail
(MHz)	(dB)	(dB μ V)	(dB μ V)	(dB μ V)	(dB)	
2437.1524	11.7	96.19	107.89	N/A	N/A	--
1090.9218	11.7	39.58	51.28	87.89	-36.61	PASS
6077.2545	11.7	43.35	55.05	87.89	-32.84	PASS
6925.9919	11.7	45.38	57.08	87.89	-30.81	PASS

High

Frequency	Offset	Reading	Level	Limit	Margin	Pass/Fail
(MHz)	(dB)	(dB μ V)	(dB μ V)	(dB μ V)	(dB)	
2462.1352	11.7	95.09	106.79	N/A	N/A	--
719.5991	11.7	39.37	51.07	86.79	-35.72	PASS
6554.6693	11.7	45.17	56.87	86.79	-29.92	PASS
6925.9919	11.7	44.77	56.47	86.79	-30.32	PASS

**IEEE 802.1120 mode Chain 0****Low**

Frequency	Offset	Reading	Level	Limit	Margin	Pass/Fail
(MHz)	(dB)	(dBμV)	(dBμV)	(dBμV)	(dB)	
2411.5365	11.7	94.84	106.54	N/A	N/A	--
1143.9679	11.7	41.26	52.96	86.54	-33.58	PASS
6024.2084	11.7	44.02	55.72	86.54	-30.82	PASS
6979.038	11.7	44.87	56.57	86.54	-29.97	PASS

Mid

Frequency	Offset	Reading	Level	Limit	Margin	Pass/Fail
(MHz)	(dB)	(dBμV)	(dBμV)	(dBμV)	(dB)	
2437.8451	11.7	92.54	104.24	N/A	N/A	--
1674.4288	11.7	40.31	52.01	84.24	-32.23	PASS
5599.8396	11.7	43.09	54.79	84.24	-29.45	PASS
6766.8537	11.7	45.46	57.16	84.24	-27.08	PASS

High

Frequency	Offset	Reading	Level	Limit	Margin	Pass/Fail
(MHz)	(dB)	(dBμV)	(dBμV)	(dBμV)	(dB)	
2462.5236	11.7	92.41	104.11	N/A	N/A	--
1143.9679	11.7	39.37	51.07	84.11	-33.04	PASS
4167.5951	11.7	40.87	52.57	84.11	-31.54	PASS
6979.038	11.7	44.34	56.04	84.11	-28.07	PASS

**IEEE 802.1120 mode Chain 1****Low**

Frequency	Offset	Reading	Level	Limit	Margin	Pass/Fail
(MHz)	(dB)	(dB μ V)	(dB μ V)	(dB μ V)	(dB)	
2412.3216	11.7	94.51	106.21	N/A	N/A	--
1621.3827	11.7	40.22	51.92	86.21	-34.29	PASS
6660.7615	11.7	44.74	56.44	86.21	-29.77	PASS
6979.038	11.7	44.01	55.71	86.21	-30.5	PASS

Mid

Frequency	Offset	Reading	Level	Limit	Margin	Pass/Fail
(MHz)	(dB)	(dB μ V)	(dB μ V)	(dB μ V)	(dB)	
2436.5214	11.7	92.6	104.3	N/A	N/A	--
1780.521	11.7	40.49	52.19	84.3	-32.11	PASS
6660.7615	11.7	44.42	56.12	84.3	-28.18	PASS
6979.038	11.7	45.16	56.86	84.3	-27.44	PASS

High

Frequency	Offset	Reading	Level	Limit	Margin	Pass/Fail
(MHz)	(dB)	(dB μ V)	(dB μ V)	(dB μ V)	(dB)	
2461.1524	11.7	92.8	104.5	N/A	N/A	--
1727.4749	11.7	41.24	52.94	84.5	-31.56	PASS
6660.7615	11.7	44.91	56.61	84.5	-27.89	PASS
6979.038	11.7	45.57	57.27	84.5	-27.23	PASS

**IEEE 802.1120 mode Combined****Low**

Frequency	Offset	Reading	Level	Limit	Margin	Pass/Fail
(MHz)	(dB)	(dBμV)	(dBμV)	(dBμV)	(dB)	
2412.3252	15.2	95.84	111.04	N/A	N/A	--
1143.9679	15.2	41.32	56.52	91.04	-34.52	PASS
6607.7154	15.2	44.31	59.51	91.04	-31.53	PASS
6979.038	15.2	43.98	59.18	91.04	-31.86	PASS

Mid

Frequency	Offset	Reading	Level	Limit	Margin	Pass/Fail
(MHz)	(dB)	(dBμV)	(dBμV)	(dBμV)	(dB)	
2437.5243	15.2	95.18	110.38	N/A	N/A	--
984.8296	15.2	39.4	54.6	90.38	-35.78	PASS
6660.7615	15.2	44.63	59.83	90.38	-30.55	PASS
6925.9919	15.2	44.72	59.92	90.38	-30.46	PASS

High

Frequency	Offset	Reading	Level	Limit	Margin	Pass/Fail
(MHz)	(dB)	(dBμV)	(dBμV)	(dBμV)	(dB)	
2462.1554	15.2	94.33	109.53	N/A	N/A	--
1143.9679	15.2	40.72	55.92	89.53	-33.61	PASS
6183.3466	15.2	42.96	58.16	89.53	-31.37	PASS
6925.9919	15.2	44.43	59.63	89.53	-29.9	PASS

**IEEE 802.1140 mode Chain 0****Low**

Frequency	Offset	Reading	Level	Limit	Margin	Pass/Fail
(MHz)	(dB)	(dBμV)	(dBμV)	(dBμV)	(dB)	
2421.6535	11.7	90.09	101.79	N/A	N/A	--
1143.9679	11.7	41.91	53.61	81.79	-28.18	PASS
5546.7935	11.7	42	53.7	81.79	-28.09	PASS
6713.8076	11.7	44.78	56.48	81.79	-25.31	PASS

Mid

Frequency	Offset	Reading	Level	Limit	Margin	Pass/Fail
(MHz)	(dB)	(dBμV)	(dBμV)	(dBμV)	(dB)	
2437.5214	11.7	93.39	105.09	N/A	N/A	--
1090.9218	11.7	39.88	51.58	85.09	-33.51	PASS
5918.1162	11.7	44.13	55.83	85.09	-29.26	PASS
6979.038	11.7	44.49	56.19	85.09	-28.9	PASS

High

Frequency	Offset	Reading	Level	Limit	Margin	Pass/Fail
(MHz)	(dB)	(dBμV)	(dBμV)	(dBμV)	(dB)	
2451.2536	11.7	89.41	101.11	N/A	N/A	--
1727.4749	11.7	41.14	52.84	81.11	-28.27	PASS
5546.7935	11.7	42.59	54.29	81.11	-26.82	PASS
6554.6693	11.7	44.92	56.62	81.11	-24.49	PASS

**IEEE 802.1140 mode Chain 1****Low**

Frequency	Offset	Reading	Level	Limit	Margin	Pass/Fail
(MHz)	(dB)	(dBμV)	(dBμV)	(dBμV)	(dB)	
2422.5365	11.7	90.58	102.28	N/A	N/A	--
1939.6593	11.7	40.02	51.72	82.28	-30.56	PASS
6607.7154	11.7	44.08	55.78	82.28	-26.5	PASS
6925.9919	11.7	44.54	56.24	82.28	-26.04	PASS

Mid

Frequency	Offset	Reading	Level	Limit	Margin	Pass/Fail
(MHz)	(dB)	(dBμV)	(dBμV)	(dBμV)	(dB)	
2436.5213	11.7	93.52	105.22	N/A	N/A	--
1727.4749	11.7	41.15	52.85	85.22	-32.37	PASS
6183.3466	11.7	43.57	55.27	85.22	-29.95	PASS
6713.8076	11.7	45.24	56.94	85.22	-28.28	PASS

High

Frequency	Offset	Reading	Level	Limit	Margin	Pass/Fail
(MHz)	(dB)	(dBμV)	(dBμV)	(dBμV)	(dB)	
2452.6532	11.7	90.49	102.19	N/A	N/A	--
1727.4749	11.7	40.3	52	82.19	-30.19	PASS
5971.1623	11.7	42.14	53.84	82.19	-28.35	PASS
6925.9919	11.7	44.66	56.36	82.19	-25.83	PASS

**IEEE 802.1140 mode Combined****Low**

Frequency	Offset	Reading	Level	Limit	Margin	Pass/Fail
(MHz)	(dB)	(dBμV)	(dBμV)	(dBμV)	(dB)	
2422.3526	15.2	91.09	106.29	N/A	N/A	--
1143.9679	15.2	41.8	57	86.29	-29.29	PASS
5971.1623	15.2	42.95	58.15	86.29	-28.14	PASS
5979.038	15.2	44.38	59.58	86.29	-26.71	PASS

Mid

Frequency	Offset	Reading	Level	Limit	Margin	Pass/Fail
(MHz)	(dB)	(dBμV)	(dBμV)	(dBμV)	(dB)	
2437.5262	15.2	91.96	107.16	N/A	N/A	--
1143.9679	15.2	39.69	54.89	87.16	-32.27	PASS
5971.1623	15.2	42.87	58.07	87.16	-29.09	PASS
5660.7615	15.2	44.56	59.76	87.16	-27.4	PASS

High

Frequency	Offset	Reading	Level	Limit	Margin	Pass/Fail
(MHz)	(dB)	(dBμV)	(dBμV)	(dBμV)	(dB)	
2452.6854	15.2	91.33	106.53	N/A	N/A	--
1143.9679	15.2	42.82	58.02	86.53	-28.51	PASS
5918.1162	15.2	43.45	58.65	86.53	-27.88	PASS
6501.6232	15.2	44.14	59.34	86.53	-27.19	PASS



OUT-OF-BAND SPURIOUS EMISSIONS-CONDUCTED MEASUREMENT (IEEE 802.11b MODE)

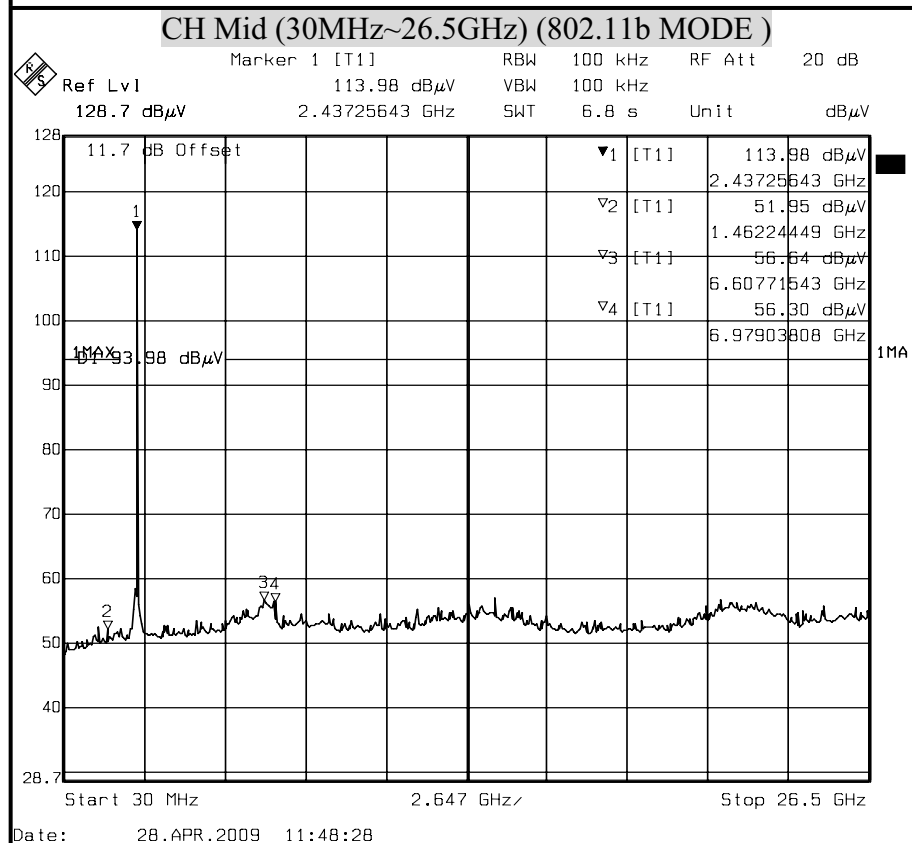
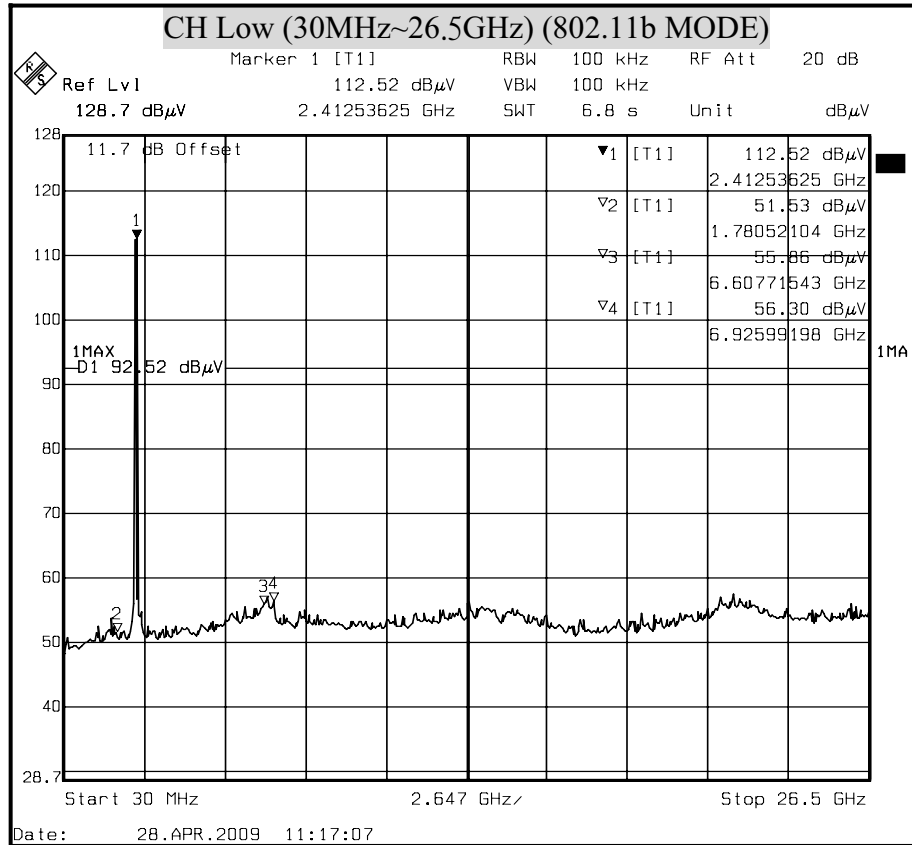

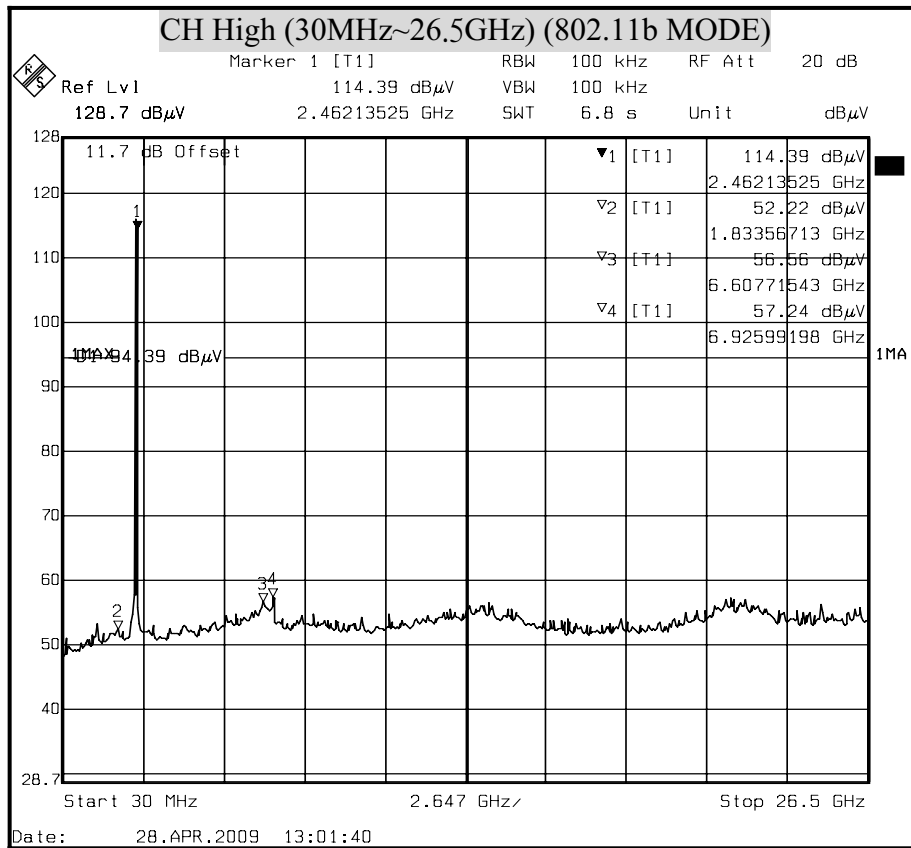



OUT-OF-BAND SPURIOUS EMISSIONS-CONDUCTED MEASUREMENT

(802.11g MODE)

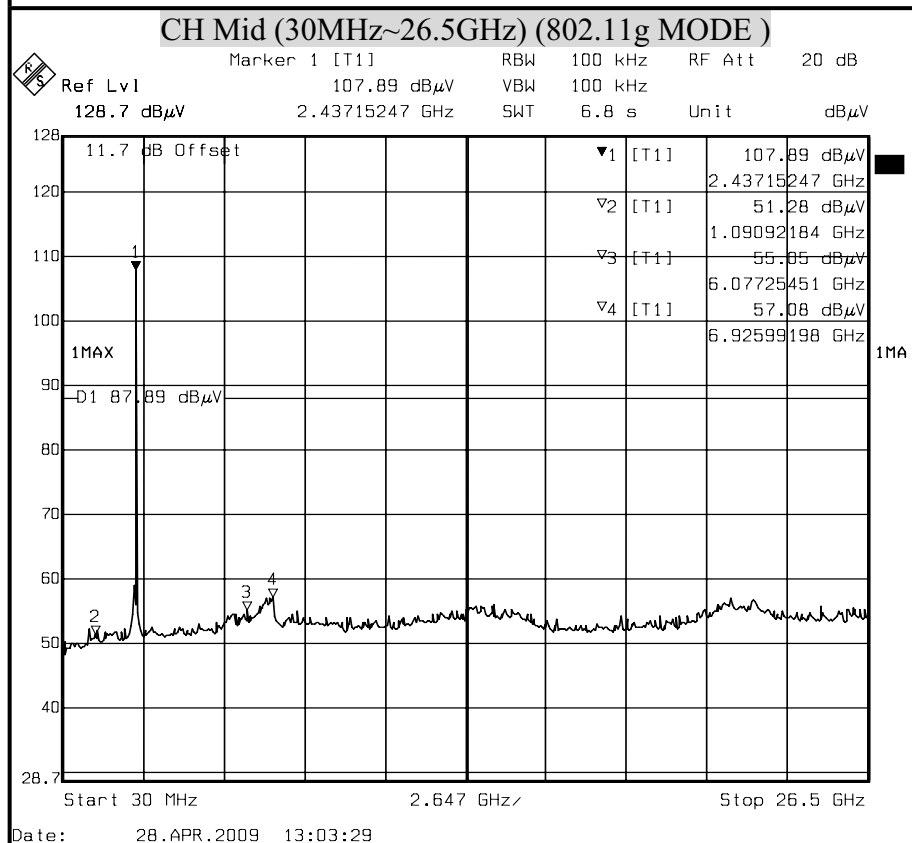
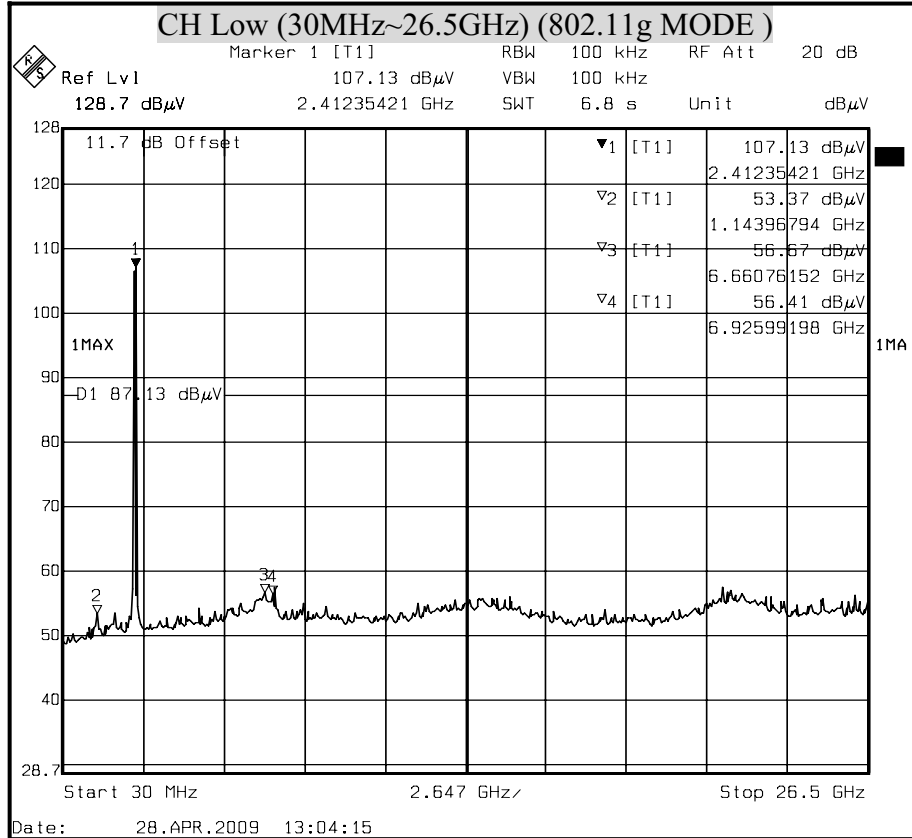

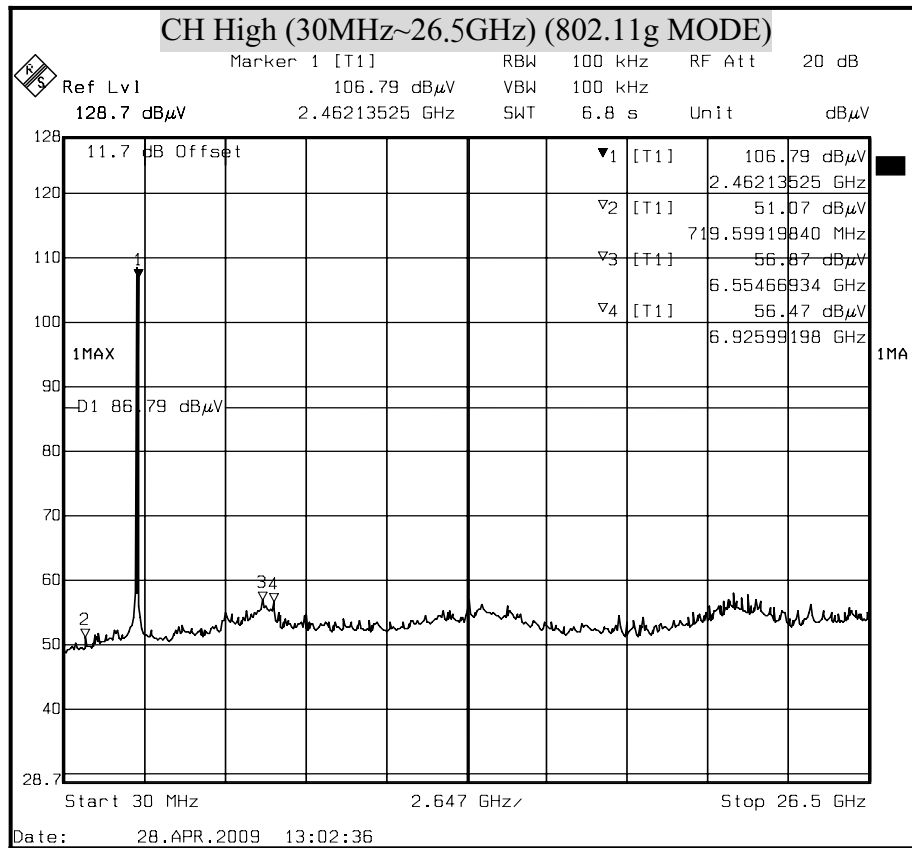

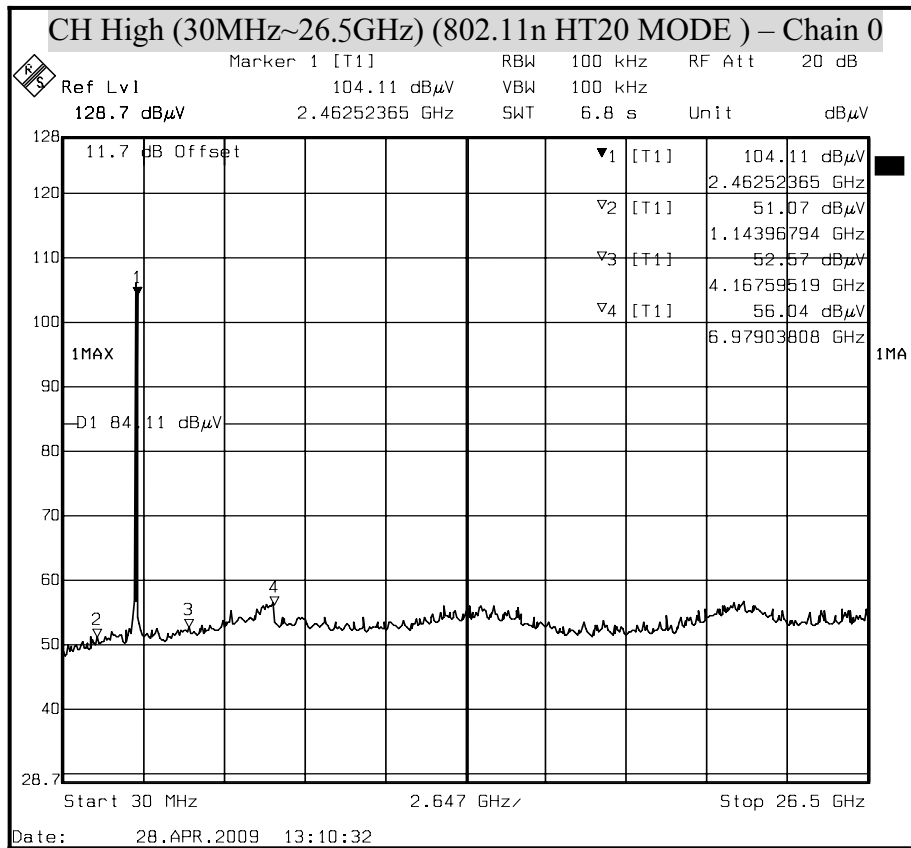

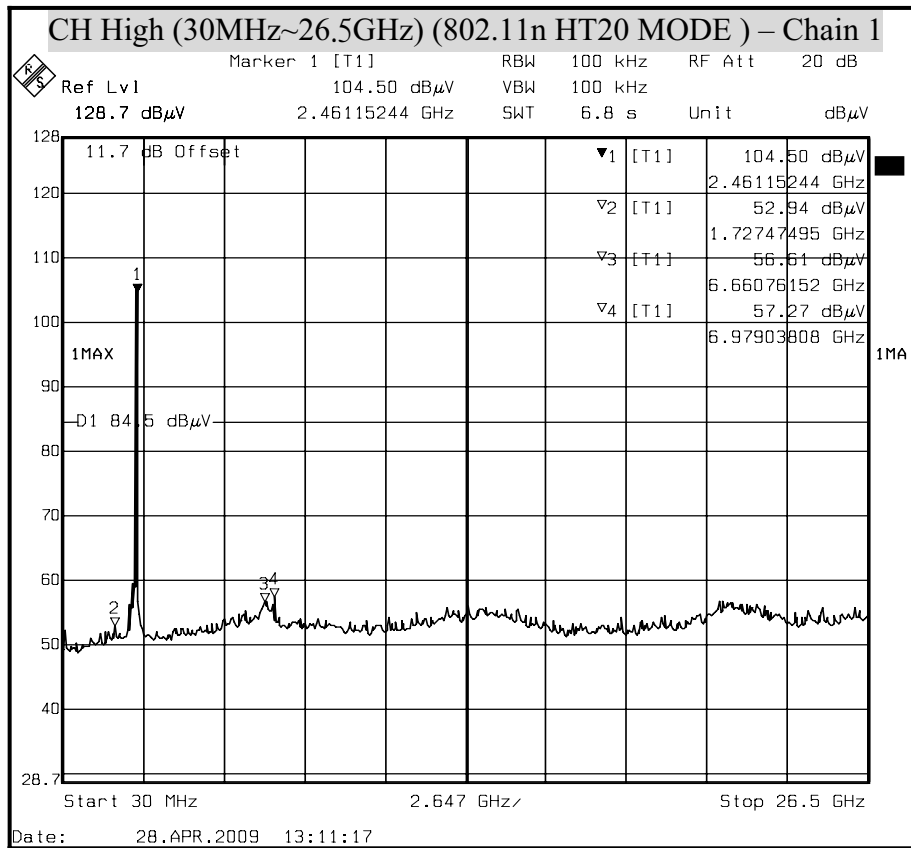

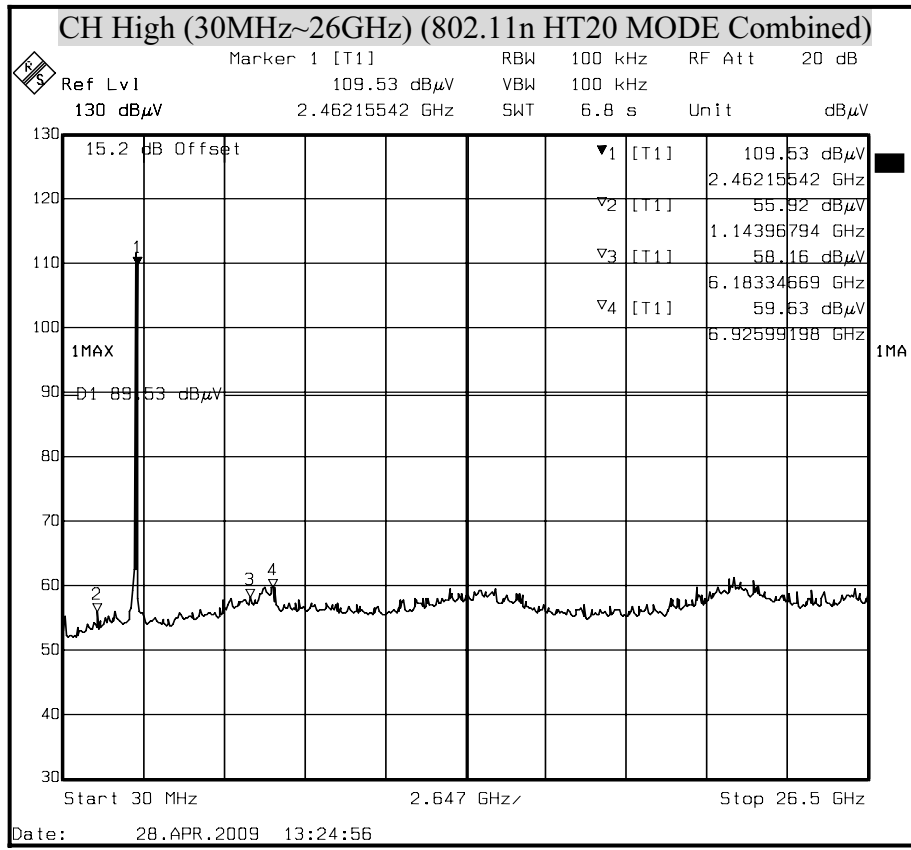

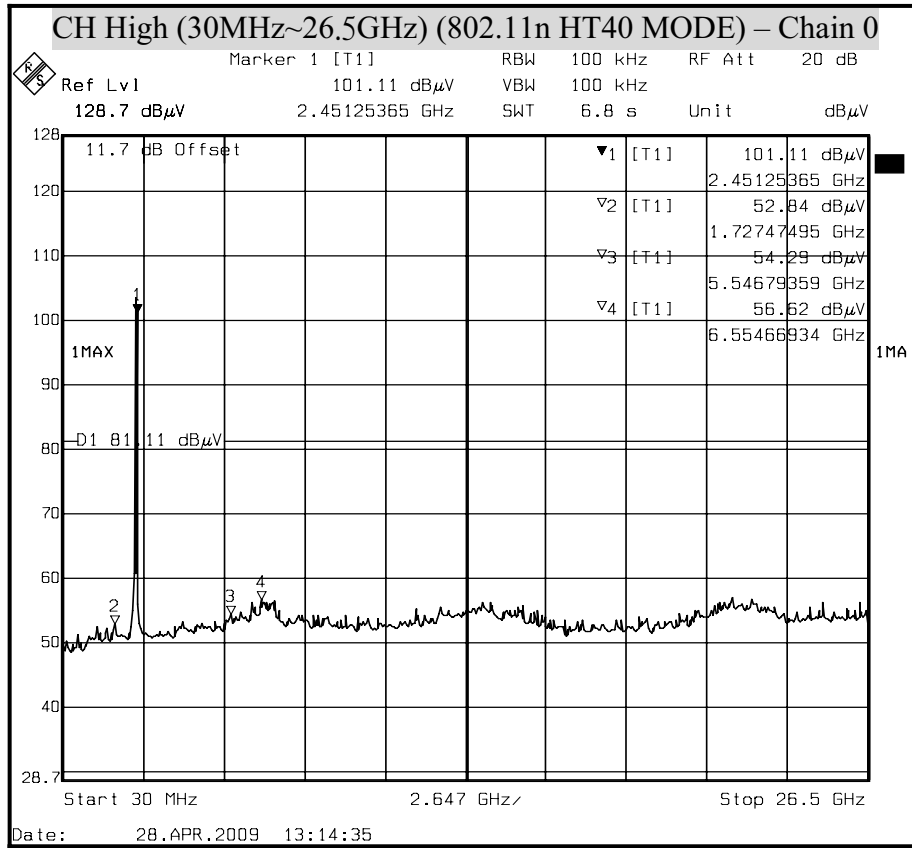

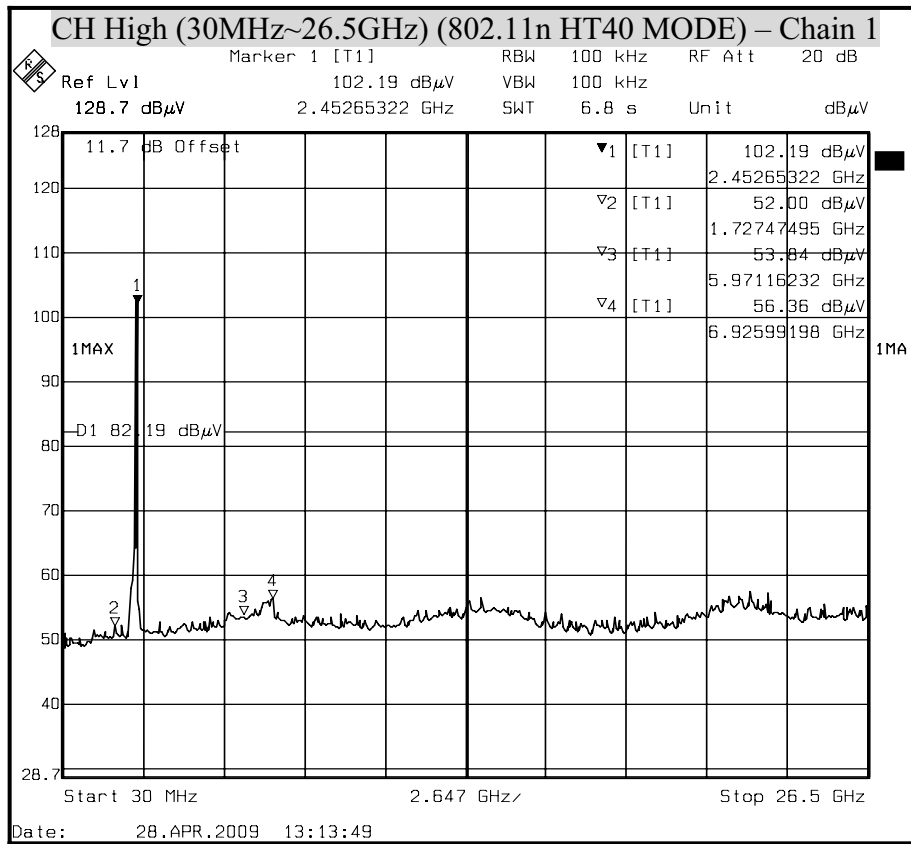



OUT-OF-BAND COMBINED SPURIOUS EMISSIONS-CONDUCTED MEASUREMENT

(802.11n HT40 MODE Combined)

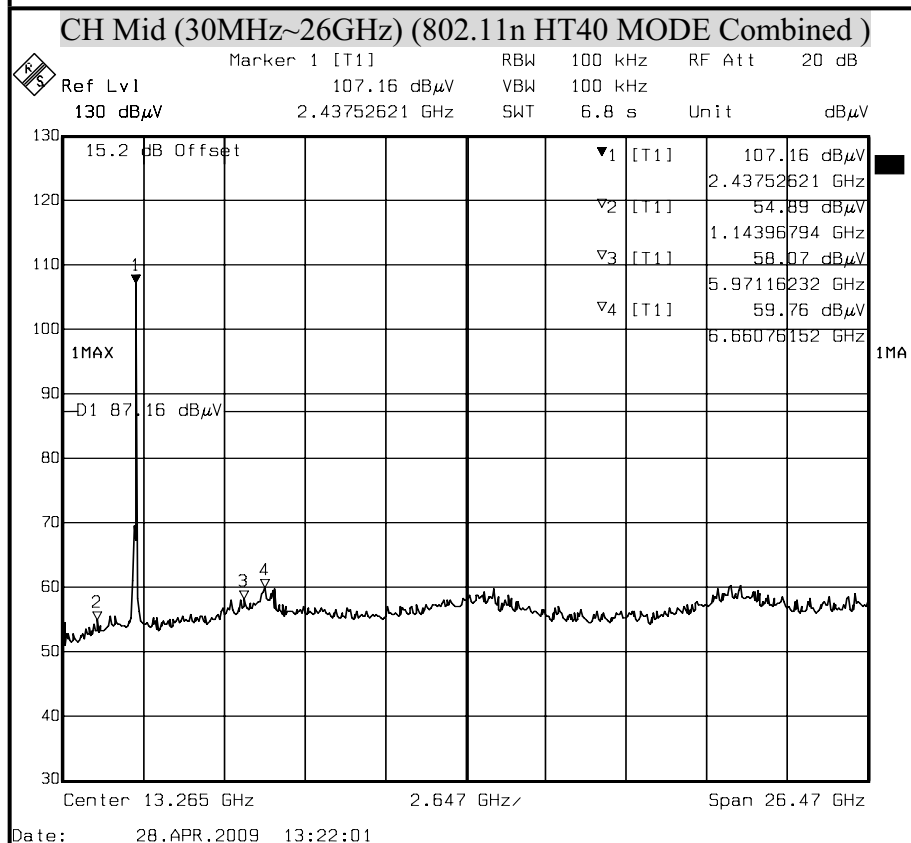
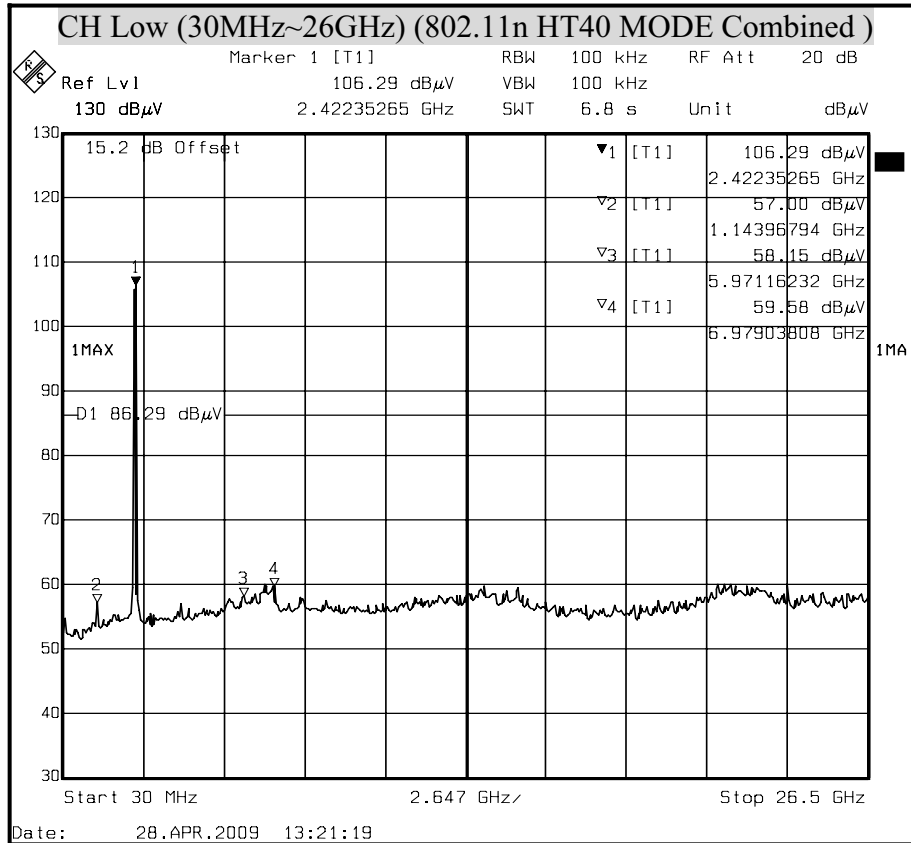

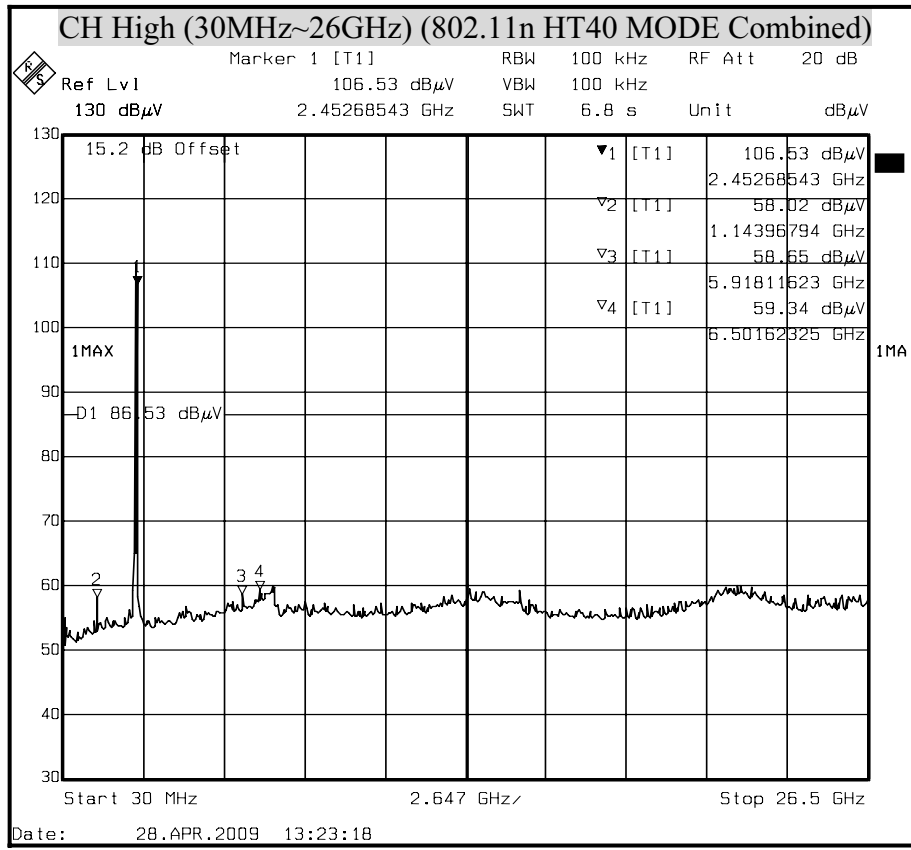



8.6 RADIATED EMISSIONS

8.6.1 TRANSMITTER RADIATED SUPURIOUS EMSSIONS

LIMITS

§ 15.205 (a) Except as shown in paragraph (d) of this section, only spurious emissions are permitted in any of the frequency bands listed below:

MHz	MHz	MHz	GHz
0.090 - 0.110	16.42 - 16.423	399.9 - 410	4.5 - 5.15
¹ 0.495 - 0.505	16.69475 - 16.69525	608 - 614	5.35 - 5.46
2.1735 - 2.1905	16.80425 - 16.80475	960 - 1240	7.25 - 7.75
4.125 - 4.128	25.5 - 25.67	1300 - 1427	8.025 - 8.5
4.17725 - 4.17775	37.5 - 38.25	1435 - 1626.5	9.0 - 9.2
4.20725 - 4.20775	73 - 74.6	1645.5 - 1646.5	9.3 - 9.5
6.215 - 6.218	74.8 - 75.2	1660 - 1710	10.6 - 12.7
6.26775 - 6.26825	108 - 121.94	1718.8 - 1722.2	13.25 - 13.4
6.31175 - 6.31225	123 - 138	2200 - 2300	14.47 - 14.5
8.291 - 8.294	149.9 - 150.05	2310 - 2390	15.35 - 16.2
8.362 - 8.366	156.52475 - 156.52525	2483.5 - 2500	17.7 - 21.4
8.37625 - 8.38675	156.7 - 156.9	2655 - 2900	22.01 - 23.12
8.41425 - 8.41475	162.0125 - 167.17	3260 - 3267	23.6 - 24.0
12.29 - 12.293	167.72 - 173.2	3332 - 3339	31.2 - 31.8
12.51975 - 12.52025	240 - 285	3345.8 - 3338	36.43 - 36.5
12.57675 - 12.57725	322 - 335.4	3600 - 4400	(²)
13.36 - 13.41			

¹ Until February 1, 1999, this restricted band shall be 0.490-0.510 MHz.

² Above 38.6

§ 15.205 (b) Except as provided in paragraphs (d) and (e), the field strength of emissions appearing within these frequency bands shall not exceed the limits shown in Section 15.209. At frequencies equal to or less than 1000 MHz, compliance with the limits in Section 15.209 shall be demonstrated using measurement instrumentation employing a CISPR quasi-peak detector. Above 1000 MHz, compliance with the emission limits in Section 15.209 shall be demonstrated based on the average value of the measured emissions. The provisions in Section 15.35 apply to these measurements.



§ 15.209 (a) Except as provided elsewhere in this Subpart, the emissions from an intentional radiator shall not exceed the field strength levels specified in the following table :

Frequency (MHz)	Field Strength (microvolts/meter)	Measurement Distance (meters)
30 - 88	100 **	3
88 - 216	150 **	3
216 - 960	200 **	3
Above 960	500	3

** Except as provided in paragraph (g), fundamental emissions from intentional radiators operating under this Section shall not be located in the frequency bands 54-72 MHz, 76-88 MHz, 174-216 MHz or 470-806 MHz, However, operation within these frequency bands is permitted under other sections of this Part, e-g, Sections 15.231 and 15.241.

§ 15.209 (b) In the emission table above, the tighter limit applies at the band edges.

TEST EQUIPMENTS

The following test equipments are utilized in making the measurements contained in this report.

Open Area Test Site # 6				
Name of Equipment	Manufacturer	Model	Serial Number	Calibration Due
TYPE N COAXIAL CABLE	SUHNER	CHA9513	005	AUG. 26, 2009
EMI Receiver	R&S	ESVS10	833206/012	APR. 28, 2010
Spectrum Analyzer	R&S	FSEK 30	835253/002	OCT. 14, 2009
BI-LOG Antenna	Sunol	JB1	A070506-2	SEP. 08, 2009
Horn Antenna	Com-Power	AH-118	071032	DEC. 22, 2009
SMA RF CABLE	SUHNER	SUCOFLEX104PEA	20520/4PEA	NOV. 12, 2009
Pre-Amplifier	MITEQ	AFS44-00108650-42-10P-4 4	1205908	OCT. 23, 2009
Signal Generator	HP	8673C	2938A00663	JUL. 16, 2009
Pre-Amplifier	HP	8447F	2944A03817	NOV. 01, 2009
Turn Table	Yo Chen	001	-----	N.C.R.
Antenna Tower	AR	TP1000A	309874	N.C.R.
Controller	CT	SC101	-----	N.C.R.
Test S/W	e-3 (5.04303e)			

TEST SETUP

The diagram below shows the test setup that is utilized to make the measurements for emission from 30 to 1GHz.

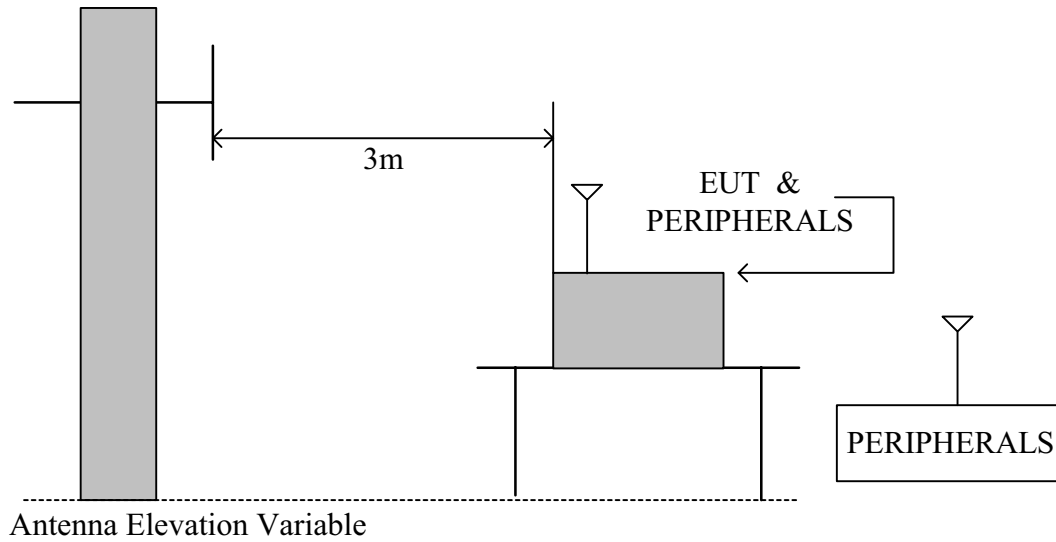

The diagram below shows the test setup that is utilized to make the measurements for emission above 1GHz.

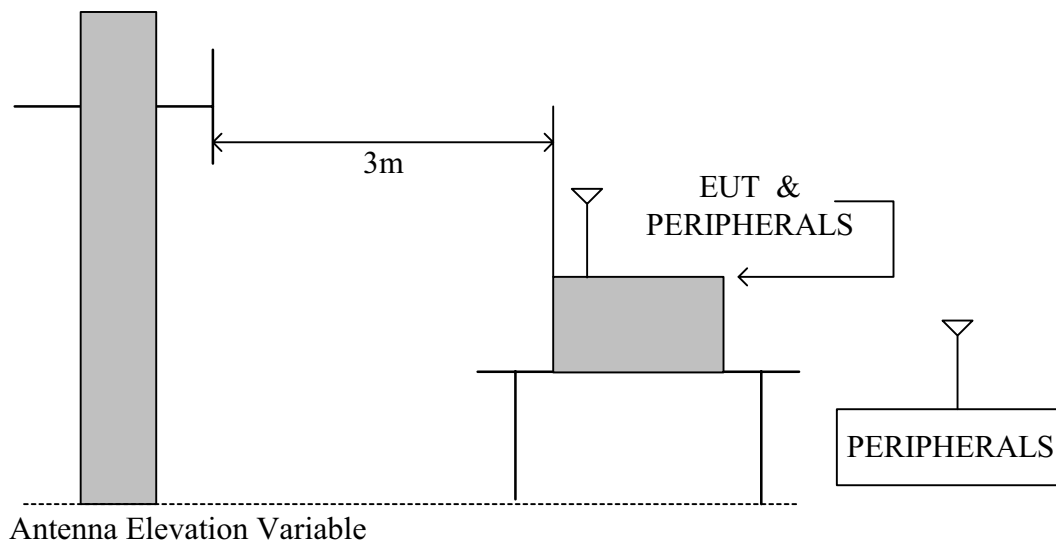



TEST PROCEDURE

- a. The EUT was placed on the top of a rotating table 0.8 meters above the ground at a 10 meter open area test site. The table was rotated 360 degrees to determine the position of the highest radiation.
- b. While measuring the radiated emission below 1GHz, the EUT was set 3 meters away from the interference-receiving antenna, which was mounted on the top of a variable-height antenna tower. While measuring the radiated emission above 1GHz, the EUT was set 3 meters away from the interference-receiving antenna
- c. The antenna is a broadband antenna, and its height is varied from one meter to four meters above the ground to determine the maximum value of the field strength. Both horizontal and vertical polarization of the antenna are set to make the measurement.
- d. For each suspected emission, the EUT was arranged to its worst case and then the antenna was tuned to heights from 1 meter to 4 meters and the table was turned from 0 degrees to 360 degrees to find the maximum reading.
- e. The test-receiver system was set to Peak Detect Function and Specified Bandwidth with Maximum Hold Mode.
- f. If the emission level of the EUT in peak mode was 10 dB lower than the limit specified, then testing could be stopped and the peak values of the EUT would be reported. Otherwise the emissions that did not have 10 dB margin would be re-tested one by one using peak, quasi-peak or average method as specified and then reported in a data sheet.

NOTE:

1. The resolution bandwidth and video bandwidth of test receiver/spectrum analyzer is 120 KHz for Peak detection (PK) and Quasi-peak detection (QP) at frequency below 1GHz.
2. The resolution bandwidth and video bandwidth of test receiver/spectrum analyzer is 1 MHz for Peak detection and frequency above 1GHz.
3. The resolution bandwidth of test receiver/spectrum analyzer is 1 MHz and the video bandwidth is 10 Hz for Average detection (AV) at frequency above 1GHz.
4. **No emission is found between lowest internal used/generated frequency to 30MHz (9kHz~30MHz)**

TEST RESULTS

No non-compliance noted.

**8.6.2 WORST-CASE RADIATED EMISSION BELOW 1 GHz**

Product Name	AirCruiser Extreme N Router	Test Date	2009/4/29
Model	GN-BR33V-RH	Test By	Eric Yang
Test Mode	Normal operating / worst case	TEMP& Humidity	27.9°C, 47%

Horizontal

Frequency	Meter Reading	Antenna Factor	Cable Loss	Emission Level	Limits	Margin	Detector Mode
(MHz)	(dB μ V)	(dB/M)	(dB)	(dB μ V/M)	(dB μ V/M)	(dB)	PK/QP
125.00	15.10	13.67	2.12	30.89	43.50	-12.61	QP
250.00	23.60	12.37	3.04	39.00	46.00	-7.00	QP
320.00	15.20	14.39	3.35	32.94	46.00	-13.06	QP
427.98	16.40	16.66	4.01	37.07	46.00	-8.93	QP
500.00	19.30	18.01	4.49	41.80	46.00	-4.20	QP
640.00	15.70	19.86	5.28	40.84	46.00	-5.16	QP
896.00	10.50	22.72	6.33	39.55	46.00	-6.45	QP
N/A	-----	-----	-----	-----	-----	-----	-----

Vertical

Frequency	Meter Reading	Antenna Factor	Cable Loss	Emission Level	Limits	Margin	Detector Mode
(MHz)	(dB μ V)	(dB/M)	(dB)	(dB μ V/M)	(dB μ V/M)	(dB)	PK/QP
53.20	22.50	8.07	1.41	31.98	40.00	-8.02	QP
125.00	16.70	13.67	2.12	32.49	43.50	-11.01	QP
320.00	19.80	14.39	3.35	37.54	46.00	-8.46	QP
427.96	16.80	16.66	4.01	37.47	46.00	-8.53	QP
500.00	20.25	18.01	4.49	42.75	46.00	-3.25	QP
640.00	16.40	19.86	5.28	41.54	46.00	-4.46	QP
896.00	9.80	22.72	6.33	38.85	46.00	-7.15	QP
N/A	-----	-----	-----	-----	-----	-----	-----

REMARK: Emission level (dB μ V/m) =Antenna Factor (dB/m) + Cable loss (dB) + Meter Reading (dB μ V).

**8.6.3 TRANSMITTER RADIATED EMISSION ABOVE 1 GHz**

Product Name	AirCruiser Extreme N Router	Test Date	2009/3/23
Model	GN-BR33V-RH	Test By	Eric Yang
Test Mode	IEEE 802.11b TX (CH Low)	TEMP& Humidity	28.1°C, 52%

Horizontal

TX / IEEE 802.11b mode / CH Low				Measurement Distance at 3m				Horizontal polarity		
Freq.	Reading	AF	Cable Loss	Pre-amp	Filter	Level	Limit	Margin	Mark	
(MHz)	(dBμV)	(dB/m)	(dB)	(dB)	(dB)	(dBμV/m)	(dBμV/m)	(dB)	(P/Q/A)	
2411.39	109.25	30.05	2.34	39.79	0.00	101.85	Fundamental Frequency		P	
2411.39	103.21	30.05	2.34	39.79	0.00	95.81			A	
3216.03	49.25	30.03	2.77	40.22	1.26	43.09	81.85	-38.76	P	
3216.03	42.11	30.03	2.77	40.22	1.26	35.95	75.81	-39.86	A	
* 4823.85	50.26	32.81	3.70	41.34	0.69	46.13	74.00	-27.87	P	
* 4823.85	39.87	32.81	3.70	41.34	0.69	35.74	54.00	-18.26	A	
7234.35	55.23	38.83	4.93	41.43	1.43	58.99	81.85	-22.86	P	
7234.35	43.27	38.83	4.93	41.43	1.43	47.03	75.81	-28.78	A	
9648.03	50.24	38.75	5.74	38.43	0.61	56.92	81.85	-24.93	P	
9648.03	44.16	38.75	5.74	38.43	0.61	50.84	75.81	-24.97	A	
N/A	-----	-----	-----	-----	-----	-----	-----	-----	P	
N/A	-----	-----	-----	-----	-----	-----	-----	-----	A	

REMARK:

1. AF: Antenna Factor, Cable: Cable Loss, Pre-Amp: Preamplifier gain, Filter: High Pass Filter Insertion Loss (3.5GHz)
2. Spectrum analyzer setting P(Peak): RBW=1MHz, VBW=1MHz, A(Average): RBW=1MHz, VBW=10Hz
3. The result basic equation calculation is as follow:
Level = Reading + AF + Cable – Preamp + Filter – Dist, Margin = Level-Limit
4. The other emission levels were 20dB below the limit
5. The test limit distance is 3M limit.



Product Name	AirCruiser Extreme N Router	Test Date	2009/3/23
Model	GN-BR33V-RH	Test By	Eric Yang
Test Mode	IEEE 802.11b TX (CH Low)	TEMP& Humidity	28.1°C, 52%

Vertical

TX / IEEE 802.11b mode / CH Low				Measurement Distance at 3m				Vertical polarity		
Freq.	Reading	AF	Cable Loss	Pre-amp	Filter	Level	Limit	Margin	Mark	
(MHz)	(dBμV)	(dB/m)	(dB)	(dB)	(dB)	(dBμV/m)	(dBμV/m)	(dB)	(P/Q/A)	
2410.23	115.86	30.05	2.34	39.79	0.00	108.46	Fundamental Frequency		P	
2410.23	109.24	30.05	2.34	39.79	0.00	101.84			A	
3215.88	51.54	30.03	2.77	40.22	1.26	45.38	88.46	-43.08	P	
3215.88	44.11	30.03	2.77	40.22	1.26	37.95	81.84	-43.89	A	
* 4824.86	52.84	32.81	3.71	41.34	0.69	48.72	74.00	-25.28	P	
* 4824.86	41.22	32.81	3.71	41.34	0.69	37.10	54.00	-16.90	A	
7234.53	58.22	38.83	4.93	41.43	1.43	61.98	88.46	-26.48	P	
7234.53	48.59	38.83	4.93	41.43	1.43	52.35	81.84	-29.49	A	
9648.05	51.43	38.75	5.74	38.43	0.61	58.11	88.46	-30.35	P	
9648.05	46.59	38.75	5.74	38.43	0.61	53.27	81.84	-28.57	A	
N/A	-----	-----	-----	-----	-----	-----	-----	-----	P	
N/A	-----	-----	-----	-----	-----	-----	-----	-----	A	

REMARK:

1. AF: Antenna Factor, Cable: Cable Loss, Pre-Amp: Preamplifier gain, Filter: High Pass Filter Insertion Loss (3.5GHz)
2. Spectrum analyzer setting P(Peak): RBW=1MHz, VBW=1MHz, A(Average): RBW=1MHz, VBW=10Hz
3. The result basic equation calculation is as follow:

$$\text{Level} = \text{Reading} + \text{AF} + \text{Cable} - \text{Preamp} + \text{Filter} - \text{Dist}, \text{Margin} = \text{Level} - \text{Limit}$$
4. The other emission levels were 20dB below the limit
5. The test limit distance is 3M limit.



Product Name	AirCruiser Extreme N Router	Test Date	2009/3/23
Model	GN-BR33V-RH	Test By	Eric Yang
Test Mode	IEEE 802.11b TX (CH Middle)	TEMP& Humidity	28.1 °C, 52%

Horizontal

	TX / IEEE 802.11b mode / CH Middle				Measurement Distance at 3m			Horizontal polarity		
	Freq. (MHz)	Reading (dBµV)	AF (dB/m)	Cable Loss (dB)	Pre-amp (dB)	Filter (dB)	Level (dBµV/m)	Limit (dBµV/m)	Margin (dB)	Mark (P/Q/A)
	2438.11	110.24	30.04	2.34	39.77	0.00	102.85	Fundamental Frequency		P
	2438.11	103.87	30.04	2.34	39.77	0.00	96.48			A
	3249.29	50.24	30.05	2.82	40.24	1.22	44.08	82.85	-38.77	P
	3249.29	41.37	30.05	2.82	40.24	1.22	35.21	76.48	-41.27	A
*	4972.85	50.26	33.14	3.79	41.56	0.75	46.38	74.00	-27.62	P
*	4972.85	39.85	33.14	3.79	41.56	0.75	35.97	54.00	-18.03	A
*	7309.24	52.15	38.93	4.96	41.32	1.59	56.31	74.00	-17.69	P
*	7309.24	42.67	38.93	4.96	41.32	1.59	46.83	54.00	-7.17	A
	9748.11	52.71	38.85	5.75	38.24	0.55	59.62	82.85	-23.23	P
	9748.11	50.56	38.85	5.75	38.24	0.55	57.47	76.48	-19.01	A
	N/A	-----	-----	-----	-----	-----	-----	-----	-----	P
	N/A	-----	-----	-----	-----	-----	-----	-----	-----	A

REMARK:

1. AF: Antenna Factor, Cable: Cable Loss, Pre-Amp: Preamplifier gain, Filter: High Pass Filter Insertion Loss (3.5GHz)
2. Spectrum analyzer setting P(Peak): RBW=1MHz, VBW=1MHz, A(Average): RBW=1MHz, VBW=10Hz
3. The result basic equation calculation is as follow:

$$\text{Level} = \text{Reading} + \text{AF} + \text{Cable} - \text{Preamp} + \text{Filter} - \text{Dist}, \text{Margin} = \text{Level} - \text{Limit}$$
4. The other emission levels were 20dB below the limit
5. The test limit distance is 3M limit.



Product Name	AirCruiser Extreme N Router	Test Date	2009/3/23
Model	GN-BR33V-RH	Test By	Eric Yang
Test Mode	IEEE 802.11b TX (CH Middle)	TEMP& Humidity	28.1 °C, 52%

Vertical

TX / IEEE 802.11b mode / CH Middle				Measurement Distance at 3m Vertical polarity					
Freq.	Reading	AF	Cable Loss	Pre-amp	Filter	Level	Limit	Margin	Mark
(MHz)	(dBμV)	(dB/m)	(dB)	(dB)	(dB)	(dBμV/m)	(dBμV/m)	(dB)	(P/Q/A)
2438.49	116.85	30.04	2.34	39.77	0.00	109.46	Fundamental Frequency		P
2438.49	109.85	30.04	2.34	39.77	0.00	102.46			A
3249.31	52.67	30.05	2.82	40.24	1.22	46.51	89.46	-42.95	P
3249.31	43.25	30.05	2.82	40.24	1.22	37.09	82.46	-45.37	A
* 4873.04	52.86	32.92	3.73	41.41	0.71	48.81	74.00	-25.19	P
* 4873.04	41.25	32.92	3.73	41.41	0.71	37.20	54.00	-16.80	A
* 7309.23	55.62	38.93	4.96	41.32	1.59	59.78	74.00	-14.22	P
* 7309.23	45.84	38.93	4.96	41.32	1.59	50.00	54.00	-4.00	A
9748.07	55.37	38.85	5.75	38.24	0.55	62.28	89.46	-27.18	P
9748.07	53.46	38.85	5.75	38.24	0.55	60.37	82.46	-22.09	A
N/A	-----	-----	-----	-----	-----	-----	-----	-----	P
N/A	-----	-----	-----	-----	-----	-----	-----	-----	A

REMARK:

1. AF: Antenna Factor, Cable: Cable Loss, Pre-Amp: Preamplifier gain, Filter: High Pass Filter Insertion Loss (3.5GHz)
2. Spectrum analyzer setting P(Peak): RBW=1MHz, VBW=1MHz, A(Average): RBW=1MHz, VBW=10Hz
3. The result basic equation calculation is as follow:
Level = Reading + AF + Cable – Preamp + Filter – Dist, Margin = Level-Limit
4. The other emission levels were 20dB below the limit
5. The test limit distance is 3M limit.



Product Name	AirCruiser Extreme N Router	Test Date	2009/3/23
Model	GN-BR33V-RH	Test By	Eric Yang
Test Mode	IEEE 802.11b TX (CH High)	TEMP& Humidity	28.1 °C, 52%

Horizontal

TX / IEEE 802.11b mode / CH High				Measurement Distance at 3m				Horizontal polarity		
Freq.	Reading	AF	Cable Loss	Pre-amp	Filter	Level	Limit	Margin	Mark	
(MHz)	(dBμV)	(dB/m)	(dB)	(dB)	(dB)	(dBμV/m)	(dBμV/m)	(dB)	(P/Q/A)	
2460.24	110.35	30.02	2.34	39.75	0.00	102.96	Fundamental Frequency		P	
2460.24	103.65	30.02	2.34	39.75	0.00	96.26			A	
3282.63	50.24	30.07	2.87	40.27	1.17	44.08	82.96	-38.88	P	
3282.63	43.26	30.07	2.87	40.27	1.17	37.10	76.26	-39.16	A	
* 4923.15	50.14	33.03	3.76	41.48	0.73	46.18	74.00	-27.82	P	
* 4923.15	39.82	33.03	3.76	41.48	0.73	35.86	54.00	-18.14	A	
* 7383.11	51.24	39.04	4.99	41.22	1.75	55.80	74.00	-18.20	P	
* 7383.11	43.67	39.04	4.99	41.22	1.75	48.23	54.00	-5.77	A	
9848.06	50.24	38.95	5.76	38.06	0.49	57.38	82.96	-25.58	P	
9848.06	45.37	38.95	5.76	38.06	0.49	52.51	76.26	-23.75	A	
N/A	-----	-----	-----	-----	-----	-----	-----	-----	P	
N/A	-----	-----	-----	-----	-----	-----	-----	-----	A	

REMARK:

1. AF: Antenna Factor, Cable: Cable Loss, Pre-Amp: Preamplifier gain, Filter: High Pass Filter Insertion Loss (3.5GHz)
2. Spectrum analyzer setting P(Peak): RBW=1MHz, VBW=1MHz, A(Average): RBW=1MHz, VBW=10Hz
3. The result basic equation calculation is as follow:
Level = Reading + AF + Cable – Preamp + Filter – Dist, Margin = Level-Limit
4. The other emission levels were 20dB below the limit
5. The test limit distance is 3M limit.



Product Name	AirCruiser Extreme N Router	Test Date	2009/3/23
Model	GN-BR33V-RH	Test By	Eric Yang
Test Mode	IEEE 802.11b TX (CH High)	TEMP& Humidity	28.1 °C, 52%

Vertical

TX / IEEE 802.11b mode / CH High				Measurement Distance at 3m Vertical polarity					
Freq.	Reading	AF	Cable Loss	Pre-amp	Filter	Level	Limit	Margin	Mark
(MHz)	(dBμV)	(dB/m)	(dB)	(dB)	(dB)	(dBμV/m)	(dBμV/m)	(dB)	(P/Q/A)
2461.75	116.45	30.02	2.34	39.75	0.00	109.06	Fundamental Frequency		P
2461.75	109.35	30.02	2.34	39.75	0.00	101.96			A
3282.59	53.05	30.07	2.87	40.27	1.17	46.89	89.06	-42.17	P
3282.59	45.75	30.07	2.87	40.27	1.17	39.59	81.96	-42.37	A
* 4922.58	52.14	33.03	3.76	41.48	0.73	48.17	74.00	-25.83	P
* 4922.58	41.25	33.03	3.76	41.48	0.73	37.28	54.00	-16.72	A
* 7383.06	54.63	39.04	4.99	41.22	1.75	59.19	74.00	-14.81	P
* 7383.06	46.87	39.04	4.99	41.22	1.75	51.43	54.00	-2.57	A
9848.02	53.21	38.95	5.76	38.06	0.49	60.35	89.06	-28.71	P
9848.02	48.74	38.95	5.76	38.06	0.49	55.88	81.96	-26.08	A
N/A	-----	-----	-----	-----	-----	-----	-----	-----	P
N/A	-----	-----	-----	-----	-----	-----	-----	-----	A

REMARK:

1. AF: Antenna Factor, Cable: Cable Loss, Pre-Amp: Preamplifier gain, Filter: High Pass Filter Insertion Loss (3.5GHz)
2. Spectrum analyzer setting P(Peak): RBW=1MHz, VBW=1MHz, A(Average): RBW=1MHz, VBW=10Hz
3. The result basic equation calculation is as follow:

$$\text{Level} = \text{Reading} + \text{AF} + \text{Cable} - \text{Preamp} + \text{Filter} - \text{Dist}, \text{Margin} = \text{Level} - \text{Limit}$$
4. The other emission levels were 20dB below the limit
5. The test limit distance is 3M limit.



Product Name	AirCruiser Extreme N Router	Test Date	2009/3/23
Model	GN-BR33V-RH	Test By	Eric Yang
Test Mode	IEEE 802.11g TX (CH Low)	TEMP& Humidity	28.1°C, 52%

Horizontal

TX / IEEE 802.11g mode / CH Low				Measurement Distance at 3m				Horizontal polarity		
Freq.	Reading	AF	Cable Loss	Pre-amp	Filter	Level	Limit	Margin	Mark	
(MHz)	(dBμV)	(dB/m)	(dB)	(dB)	(dB)	(dBμV/m)	(dBμV/m)	(dB)	(P/Q/A)	
2412.35	106.85	30.05	2.34	39.79	0.00	99.45	Fundamental Frequency		P	
2412.35	97.31	30.05	2.34	39.79	0.00	89.91			A	
3216.02	51.24	30.03	2.77	40.22	1.26	45.08	79.45	-34.37	P	
3216.02	45.83	30.03	2.77	40.22	1.26	39.67	69.91	-30.24	A	
* 4822.75	51.24	32.81	3.70	41.33	0.69	47.11	74.00	-26.89	P	
* 4822.75	40.35	32.81	3.70	41.33	0.69	36.22	54.00	-17.78	A	
7235.28	51.42	38.83	4.93	41.43	1.43	55.19	79.45	-24.26	P	
7235.28	38.67	38.83	4.93	41.43	1.43	42.44	69.91	-27.47	A	
N/A	-----	-----	-----	-----	-----	-----	-----	-----	P	
N/A	-----	-----	-----	-----	-----	-----	-----	-----	A	

REMARK:

1. AF: Antenna Factor, Cable: Cable Loss, Pre-Amp: Preamplifier gain, Filter: High Pass Filter Insertion Loss (3.5GHz)
2. Spectrum analyzer setting P(Peak): RBW=1MHz, VBW=1MHz, A(Average): RBW=1MHz, VBW=10Hz
3. The result basic equation calculation is as follow:
Level = Reading + AF + Cable – Preamp + Filter – Dist, Margin = Level-Limit
4. The other emission levels were 20dB below the limit
5. The test limit distance is 3M limit.



Product Name	AirCruiser Extreme N Router	Test Date	2009/3/23
Model	GN-BR33V-RH	Test By	Eric Yang
Test Mode	IEEE 802.11g TX (CH Low)	TEMP& Humidity	28.1°C, 52%

Vertical

TX / IEEE 802.11g mode / CH Low				Measurement Distance at 3m				Vertical polarity	
Freq.	Reading	AF	Cable Loss	Pre-amp	Filter	Level	Limit	Margin	Mark
(MHz)	(dBμV)	(dB/m)	(dB)	(dB)	(dB)	(dBμV/m)	(dBμV/m)	(dB)	(P/Q/A)
2413.56	114.52	30.05	2.34	39.79	0.00	107.12	Fundamental Frequency		P
2413.56	106.37	30.05	2.34	39.79	0.00	98.97			A
3215.98	54.02	30.03	2.77	40.22	1.26	47.86	87.12	-39.26	P
3215.98	49.70	30.03	2.77	40.22	1.26	43.54	78.97	-35.43	A
* 4821.79	54.25	32.81	3.70	41.33	0.69	50.12	74.00	-23.88	P
* 4821.79	43.86	32.81	3.70	41.33	0.69	39.73	54.00	-14.27	A
7235.22	55.22	38.83	4.93	41.43	1.43	58.99	87.12	-28.14	P
7235.22	42.02	38.83	4.93	41.43	1.43	45.79	78.97	-33.19	A
N/A	-----	-----	-----	-----	-----	-----	-----	-----	P
N/A	-----	-----	-----	-----	-----	-----	-----	-----	A

REMARK:

1. AF: Antenna Factor, Cable: Cable Loss, Pre-Amp: Preamplifier gain, Filter: High Pass Filter Insertion Loss (3.5GHz)
2. Spectrum analyzer setting P(Peak): RBW=1MHz, VBW=1MHz, A(Average): RBW=1MHz, VBW=10Hz
3. The result basic equation calculation is as follow:
Level = Reading + AF + Cable – Preamp + Filter – Dist, Margin = Level-Limit
4. The other emission levels were 20dB below the limit
5. The test limit distance is 3M limit.



Product Name	AirCruiser Extreme N Router	Test Date	2009/3/23
Model	GN-BR33V-RH	Test By	Eric Yang
Test Mode	IEEE 802.11g TX (CH Middle)	TEMP& Humidity	28.1 °C, 52%

Horizontal

TX / IEEE 802.11g mode / CH Middle				Measurement Distance at 3m				Horizontal polarity		
Freq.	Reading	AF	Cable Loss	Pre-amp	Filter	Level	Limit	Margin	Mark	
(MHz)	(dBµV)	(dB/m)	(dB)	(dB)	(dB)	(dBµV/m)	(dBµV/m)	(dB)	(P/Q/A)	
2444.42	106.25	30.03	2.34	39.76	0.00	98.86	Fundamental Frequency		P	
2444.42	98.54	30.03	2.34	39.76	0.00	91.15			A	
3249.46	48.25	30.05	2.82	40.24	1.22	42.09	78.86	-36.77	P	
3249.46	42.51	30.05	2.82	40.24	1.22	36.35	71.15	-34.80	A	
* 4872.35	49.85	32.92	3.73	41.41	0.71	45.80	74.00	-28.20	P	
* 4872.35	40.15	32.92	3.73	41.41	0.71	36.10	54.00	-17.90	A	
* 7317.45	52.46	38.94	4.96	41.31	1.61	56.67	74.00	-17.33	P	
* 7317.45	38.97	38.94	4.96	41.31	1.61	43.18	54.00	-10.82	A	
N/A	-----	-----	-----	-----	-----	-----	-----	-----	P	
N/A	-----	-----	-----	-----	-----	-----	-----	-----	A	

REMARK:

1. AF: Antenna Factor, Cable: Cable Loss, Pre-Amp: Preamplifier gain, Filter: High Pass Filter Insertion Loss (3.5GHz)
2. Spectrum analyzer setting P(Peak): RBW=1MHz, VBW=1MHz, A(Average): RBW=1MHz, VBW=10Hz
3. The result basic equation calculation is as follow:

$$\text{Level} = \text{Reading} + \text{AF} + \text{Cable} - \text{Preamp} + \text{Filter} - \text{Dist}, \text{Margin} = \text{Level} - \text{Limit}$$
4. The other emission levels were 20dB below the limit
5. The test limit distance is 3M limit.



Product Name	AirCruiser Extreme N Router	Test Date	2009/3/23
Model	GN-BR33V-RH	Test By	Eric Yang
Test Mode	IEEE 802.11g TX (CH Middle)	TEMP& Humidity	28.1 °C, 52%

Vertical

TX / IEEE 802.11g mode / CH Middle				Measurement Distance at 3m Vertical polarity					
Freq.	Reading	AF	Cable Loss	Pre-amp	Filter	Level	Limit	Margin	Mark
(MHz)	(dBμV)	(dB/m)	(dB)	(dB)	(dB)	(dBμV/m)	(dBμV/m)	(dB)	(P/Q/A)
2439.97	114.74	30.04	2.34	39.77	0.00	107.35	Fundamental Frequency		P
2439.97	106.07	30.04	2.34	39.77	0.00	98.68			A
3249.44	50.62	30.05	2.82	40.24	1.22	44.46	87.35	-42.89	P
3249.44	44.17	30.05	2.82	40.24	1.22	38.01	78.68	-40.67	A
* 4871.25	51.24	32.92	3.73	41.41	0.71	47.19	74.00	-26.81	P
* 4871.25	42.33	32.92	3.73	41.41	0.71	38.28	54.00	-15.72	A
* 7317.34	55.41	38.94	4.96	41.31	1.61	59.62	74.00	-14.38	P
* 7317.34	41.86	38.94	4.96	41.31	1.61	46.07	54.00	-7.93	A
N/A	-----	-----	-----	-----	-----	-----	-----	-----	P
N/A	-----	-----	-----	-----	-----	-----	-----	-----	A

REMARK:

1. AF: Antenna Factor, Cable: Cable Loss, Pre-Amp: Preamplifier gain, Filter: High Pass Filter Insertion Loss (3.5GHz)
2. Spectrum analyzer setting P(Peak): RBW=1MHz, VBW=1MHz, A(Average): RBW=1MHz, VBW=10Hz
3. The result basic equation calculation is as follow:

$$\text{Level} = \text{Reading} + \text{AF} + \text{Cable} - \text{Preamp} + \text{Filter} - \text{Dist}, \text{Margin} = \text{Level} - \text{Limit}$$
4. The other emission levels were 20dB below the limit
5. The test limit distance is 3M limit.



Product Name	AirCruiser Extreme N Router	Test Date	2009/3/23
Model	GN-BR33V-RH	Test By	Eric Yang
Test Mode	IEEE 802.11g TX (CH High)	TEMP& Humidity	28.1°C, 52%

Horizontal

TX / IEEE 802.11g mode / CH High				Measurement Distance at 3m				Horizontal polarity		
Freq.	Reading	AF	Cable Loss	Pre-amp	Filter	Level	Limit	Margin	Mark	
(MHz)	(dBμV)	(dB/m)	(dB)	(dB)	(dB)	(dBμV/m)	(dBμV/m)	(dB)	(P/Q/A)	
2466.57	105.98	30.02	2.34	39.75	0.00	98.59	Fundamental Frequency		P	
2466.57	98.34	30.02	2.34	39.75	0.00	90.95			A	
3282.71	49.86	30.07	2.87	40.27	1.17	43.70	78.59	-34.89	P	
3282.71	42.35	30.07	2.87	40.27	1.17	36.19	70.95	-34.76	A	
* 4923.65	50.14	33.03	3.76	41.49	0.73	46.18	74.00	-27.82	P	
* 4923.65	39.75	33.03	3.76	41.49	0.73	35.79	54.00	-18.21	A	
* 7392.25	52.14	39.05	4.99	41.20	1.77	56.75	74.00	-17.25	P	
* 7392.25	38.97	39.05	4.99	41.20	1.77	43.58	54.00	-10.42	A	
N/A	-----	-----	-----	-----	-----	-----	-----	-----	P	
N/A	-----	-----	-----	-----	-----	-----	-----	-----	A	

REMARK:

1. AF: Antenna Factor, Cable: Cable Loss, Pre-Amp: Preamplifier gain, Filter: High Pass Filter Insertion Loss (3.5GHz)
2. Spectrum analyzer setting P(Peak): RBW=1MHz, VBW=1MHz, A(Average): RBW=1MHz, VBW=10Hz
3. The result basic equation calculation is as follow:
Level = Reading + AF + Cable – Preamp + Filter – Dist, Margin = Level-Limit
4. The other emission levels were 20dB below the limit
5. The test limit distance is 3M limit.



Product Name	AirCruiser Extreme N Router	Test Date	2009/3/23
Model	GN-BR33V-RH	Test By	Eric Yang
Test Mode	IEEE 802.11g TX (CH High)	TEMP& Humidity	28.1°C, 52%

Vertical

TX / IEEE 802.11g mode / CH High				Measurement Distance at 3m Vertical polarity					
Freq.	Reading	AF	Cable Loss	Pre-amp	Filter	Level	Limit	Margin	Mark
(MHz)	(dBμV)	(dB/m)	(dB)	(dB)	(dB)	(dBμV/m)	(dBμV/m)	(dB)	(P/Q/A)
2458.93	114.50	30.02	2.34	39.75	0.00	107.11	Fundamental Frequency		P
2458.93	106.40	30.02	2.34	39.75	0.00	99.01			A
3282.65	52.10	30.07	2.87	40.27	1.17	45.94	87.11	-41.17	P
3282.65	44.60	30.07	2.87	40.27	1.17	38.44	79.01	-40.57	A
* 4924.15	52.14	33.03	3.76	41.49	0.73	48.18	74.00	-25.82	P
* 4924.15	41.35	33.03	3.76	41.49	0.73	37.39	54.00	-16.61	A
* 7392.27	55.27	39.05	4.99	41.20	1.77	59.88	74.00	-14.12	P
* 7392.27	41.35	39.05	4.99	41.20	1.77	45.96	54.00	-8.04	A
N/A	-----	-----	-----	-----	-----	-----	-----	-----	P
N/A	-----	-----	-----	-----	-----	-----	-----	-----	A

REMARK:

1. AF: Antenna Factor, Cable: Cable Loss, Pre-Amp: Preamplifier gain, Filter: High Pass Filter Insertion Loss (3.5GHz)
2. Spectrum analyzer setting P(Peak): RBW=1MHz, VBW=1MHz, A(Average): RBW=1MHz, VBW=10Hz
3. The result basic equation calculation is as follow:

$$\text{Level} = \text{Reading} + \text{AF} + \text{Cable} - \text{Preamp} + \text{Filter} - \text{Dist}, \text{Margin} = \text{Level} - \text{Limit}$$
4. The other emission levels were 20dB below the limit
5. The test limit distance is 3M limit.



Product Name	AirCruiser Extreme N Router	Test Date	2009/3/23
Model	GN-BR33V-RH	Test By	Eric Yang
Test Mode	IEEE 802.11n HT20 TX (CH Low)	TEMP& Humidity	28.1°C, 52%

Horizontal

TX / IEEE 802.11n HT20 mode / CH Low				Measurement Distance at 3m				Horizontal polarity		
Freq.	Reading	AF	Cable Loss	Pre-amp	Filter	Level	Limit	Margin	Mark	
(MHz)	(dBμV)	(dB/m)	(dB)	(dB)	(dB)	(dBμV/m)	(dBμV/m)	(dB)	(P/Q/A)	
2414.52	109.25	30.05	2.34	39.79	0.00	101.85	Fundamental Frequency		P	
2414.52	101.81	30.05	2.34	39.79	0.00	94.41			A	
3216.03	52.14	30.03	2.77	40.22	1.26	45.98	81.85	-35.87	P	
3216.03	46.35	30.03	2.77	40.22	1.26	40.19	74.41	-34.22	A	
* 4823.57	51.14	32.81	3.70	41.34	0.69	47.01	74.00	-26.99	P	
* 4823.57	38.67	32.81	3.70	41.34	0.69	34.54	54.00	-19.46	A	
7242.48	65.34	38.84	4.93	41.42	1.45	69.14	81.85	-12.71	P	
7242.48	50.26	38.84	4.93	41.42	1.45	54.06	74.41	-20.35	A	
N/A	-----	-----	-----	-----	-----	-----	-----	-----	P	
N/A	-----	-----	-----	-----	-----	-----	-----	-----	A	

REMARK:

1. AF: Antenna Factor, Cable: Cable Loss, Pre-Amp: Preamplifier gain, Filter: High Pass Filter Insertion Loss (3.5GHz)
2. Spectrum analyzer setting P(Peak): RBW=1MHz, VBW=1MHz, A(Average): RBW=1MHz, VBW=10Hz
3. The result basic equation calculation is as follow:
Level = Reading + AF + Cable – Preamp + Filter – Dist, Margin = Level-Limit
4. The other emission levels were 20dB below the limit
5. The test limit distance is 3M limit.



Product Name	AirCruiser Extreme N Router	Test Date	2009/3/23
Model	GN-BR33V-RH	Test By	Eric Yang
Test Mode	IEEE 802.11n HT20 TX (CH Low)	TEMP& Humidity	28.1°C, 52%

Vertical

TX / IEEE 802.11n HT20 mode / CH Low				Measurement Distance at 3m				Vertical polarity		
Freq.	Reading	AF	Cable Loss	Pre-amp	Filter	Level	Limit	Margin	Mark	
(MHz)	(dBμV)	(dB/m)	(dB)	(dB)	(dB)	(dBμV/m)	(dBμV/m)	(dB)	(P/Q/A)	
2411.35	116.97	30.05	2.34	39.79	0.00	109.57	Fundamental Frequency		P	
2411.35	109.27	30.05	2.34	39.79	0.00	101.87			A	
3215.98	54.14	30.03	2.77	40.22	1.26	47.98	89.57	-41.59	P	
3215.98	48.71	30.03	2.77	40.22	1.26	42.55	81.87	-39.32	A	
* 4822.35	53.23	32.81	3.70	41.33	0.69	49.10	74.00	-24.90	P	
* 4822.35	40.90	32.81	3.70	41.33	0.69	36.77	54.00	-17.23	A	
7242.52	68.95	38.84	4.93	41.42	1.45	72.75	89.57	-16.82	P	
7242.52	53.64	38.84	4.93	41.42	1.45	57.44	81.87	-24.43	A	
N/A	-----	-----	-----	-----	-----	-----	-----	-----	P	
N/A	-----	-----	-----	-----	-----	-----	-----	-----	A	

REMARK:

1. AF: Antenna Factor, Cable: Cable Loss, Pre-Amp: Preamplifier gain, Filter: High Pass Filter Insertion Loss (3.5GHz)
2. Spectrum analyzer setting P(Peak): RBW=1MHz, VBW=1MHz, A(Average): RBW=1MHz, VBW=10Hz
3. The result basic equation calculation is as follow:
Level = Reading + AF + Cable – Preamp + Filter – Dist, Margin = Level-Limit
4. The other emission levels were 20dB below the limit
5. The test limit distance is 3M limit.



Product Name	AirCruiser Extreme N Router	Test Date	2009/3/23
Model	GN-BR33V-RH	Test By	Eric Yang
Test Mode	IEEE 802.11n HT20 TX (CH Middle)	TEMP& Humidity	28.1°C, 52%

Horizontal

TX / IEEE 802.11n HT20 mode / CH Middle				Measurement Distance at 3m				Horizontal polarity		
Freq.	Reading	AF	Cable Loss	Pre-amp	Filter	Level	Limit	Margin	Mark	
(MHz)	(dBμV)	(dB/m)	(dB)	(dB)	(dB)	(dBμV/m)	(dBμV/m)	(dB)	(P/Q/A)	
2432.95	108.26	30.04	2.34	39.77	0.00	100.87	Fundamental Frequency		P	
2432.95	101.13	30.04	2.34	39.77	0.00	93.74			A	
3249.28	49.85	30.05	2.82	40.24	1.22	43.69	80.87	-37.18	P	
3249.28	42.15	30.05	2.82	40.24	1.22	35.99	73.74	-37.75	A	
* 4871.65	49.85	32.92	3.73	41.41	0.71	45.80	74.00	-28.20	P	
* 4871.65	40.35	32.92	3.73	41.41	0.71	36.30	54.00	-17.70	A	
* 7309.28	51.12	38.93	4.96	41.32	1.59	55.28	74.00	-18.72	P	
* 7309.28	45.26	38.93	4.96	41.32	1.59	49.42	54.00	-4.58	A	
N/A	-----	-----	-----	-----	-----	-----	-----	-----	P	
N/A	-----	-----	-----	-----	-----	-----	-----	-----	A	

REMARK:

1. AF: Antenna Factor, Cable: Cable Loss, Pre-Amp: Preamplifier gain, Filter: High Pass Filter Insertion Loss (3.5GHz)
2. Spectrum analyzer setting P(Peak): RBW=1MHz, VBW=1MHz, A(Average): RBW=1MHz, VBW=10Hz
3. The result basic equation calculation is as follow:

$$\text{Level} = \text{Reading} + \text{AF} + \text{Cable} - \text{Preamp} + \text{Filter} - \text{Dist}, \text{Margin} = \text{Level} - \text{Limit}$$
4. The other emission levels were 20dB below the limit
5. The test limit distance is 3M limit.



Product Name	AirCruiser Extreme N Router	Test Date	2009/3/23
Model	GN-BR33V-RH	Test By	Eric Yang
Test Mode	IEEE 802.11n HT20 TX (CH Middle)	TEMP& Humidity	28.1°C, 52%

Vertical

TX / IEEE 802.11n HT20 mode / CH Middle				Measurement Distance at 3m Vertical polarity					
Freq.	Reading	AF	Cable Loss	Pre-amp	Filter	Level	Limit	Margin	Mark
(MHz)	(dBμV)	(dB/m)	(dB)	(dB)	(dB)	(dBμV/m)	(dBμV/m)	(dB)	(P/Q/A)
2429.98	115.21	30.04	2.34	39.78	0.00	107.81	Fundamental Frequency		P
2429.98	108.26	30.04	2.34	39.78	0.00	100.86			A
3249.30	51.80	30.05	2.82	40.24	1.22	45.64	87.81	-42.17	P
3249.30	44.36	30.05	2.82	40.24	1.22	38.20	80.86	-42.66	A
* 4872.68	51.24	32.92	3.73	41.41	0.71	47.19	74.00	-26.81	P
* 4872.68	42.36	32.92	3.73	41.41	0.71	38.31	54.00	-15.69	A
* 7309.35	54.80	38.93	4.96	41.32	1.59	58.96	74.00	-15.04	P
* 7309.35	48.56	38.93	4.96	41.32	1.59	52.72	54.00	-1.28	A
N/A	-----	-----	-----	-----	-----	-----	-----	-----	P
N/A	-----	-----	-----	-----	-----	-----	-----	-----	A

REMARK:

1. AF: Antenna Factor, Cable: Cable Loss, Pre-Amp: Preamplifier gain, Filter: High Pass Filter Insertion Loss (3.5GHz)
2. Spectrum analyzer setting P(Peak): RBW=1MHz, VBW=1MHz, A(Average): RBW=1MHz, VBW=10Hz
3. The result basic equation calculation is as follow:

$$\text{Level} = \text{Reading} + \text{AF} + \text{Cable} - \text{Preamp} + \text{Filter} - \text{Dist}, \text{Margin} = \text{Level} - \text{Limit}$$
4. The other emission levels were 20dB below the limit
5. The test limit distance is 3M limit.



Product Name	AirCruiser Extreme N Router	Test Date	2009/3/23
Model	GN-BR33V-RH	Test By	Eric Yang
Test Mode	IEEE 802.11n HT20 TX (CH High)	TEMP& Humidity	28.1 °C, 52%

Horizontal

TX / IEEE 802.11n HT20 mode / CH High				Measurement Distance at 3m				Horizontal polarity	
Freq.	Reading	AF	Cable Loss	Pre-amp	Filter	Level	Limit	Margin	Mark
(MHz)	(dBµV)	(dB/m)	(dB)	(dB)	(dB)	(dBµV/m)	(dBµV/m)	(dB)	(P/Q/A)
2468.89	107.23	30.02	2.34	39.74	0.00	99.84	Fundamental Frequency		P
2468.89	100.25	30.02	2.34	39.74	0.00	92.86			A
3282.59	49.85	30.07	2.87	40.27	1.17	43.69	79.84	-36.15	P
3282.59	42.31	30.07	2.87	40.27	1.17	36.15	72.86	-36.71	A
* 4924.75	51.42	33.03	3.76	41.49	0.73	47.46	74.00	-26.54	P
* 4924.75	39.85	33.03	3.76	41.49	0.73	35.89	54.00	-18.11	A
* 7382.05	59.87	39.03	4.99	41.22	1.75	64.43	74.00	-9.57	P
* 7382.05	43.67	39.03	4.99	41.22	1.75	48.23	54.00	-5.77	A
N/A	-----	-----	-----	-----	-----	-----	-----	-----	P
N/A	-----	-----	-----	-----	-----	-----	-----	-----	A

REMARK:

1. AF: Antenna Factor, Cable: Cable Loss, Pre-Amp: Preamplifier gain, Filter: High Pass Filter Insertion Loss (3.5GHz)
2. Spectrum analyzer setting P(Peak): RBW=1MHz, VBW=1MHz, A(Average): RBW=1MHz, VBW=10Hz
3. The result basic equation calculation is as follow:

$$\text{Level} = \text{Reading} + \text{AF} + \text{Cable} - \text{Preamp} + \text{Filter} - \text{Dist}, \text{Margin} = \text{Level} - \text{Limit}$$
4. The other emission levels were 20dB below the limit
5. The test limit distance is 3M limit.



Product Name	AirCruiser Extreme N Router	Test Date	2009/3/23
Model	GN-BR33V-RH	Test By	Eric Yang
Test Mode	IEEE 802.11n HT20 TX (CH High)	TEMP& Humidity	28.1 °C, 52%

Vertical

TX / IEEE 802.11n HT20 mode / CH High				Measurement Distance at 3m				Vertical polarity	
Freq.	Reading	AF	Cable Loss	Pre-amp	Filter	Level	Limit	Margin	Mark
(MHz)	(dBμV)	(dB/m)	(dB)	(dB)	(dB)	(dBμV/m)	(dBμV/m)	(dB)	(P/Q/A)
2467.69	115.53	30.02	2.34	39.75	0.00	108.14	Fundamental Frequency		P
2467.69	107.32	30.02	2.34	39.75	0.00	99.93			A
3282.64	51.70	30.07	2.87	40.27	1.17	45.54	88.14	-42.60	P
3282.64	44.96	30.07	2.87	40.27	1.17	38.80	79.93	-41.13	A
* 4923.76	54.59	33.03	3.76	41.49	0.73	50.63	74.00	-23.37	P
* 4923.76	42.57	33.03	3.76	41.49	0.73	38.61	54.00	-15.39	A
* 7382.14	63.01	39.03	4.99	41.22	1.75	67.57	74.00	-6.43	P
* 7382.14	47.19	39.03	4.99	41.22	1.75	51.75	54.00	-2.25	A
N/A	-----	-----	-----	-----	-----	-----	-----	-----	P
N/A	-----	-----	-----	-----	-----	-----	-----	-----	A

REMARK:

1. AF: Antenna Factor, Cable: Cable Loss, Pre-Amp: Preamplifier gain, Filter: High Pass Filter Insertion Loss (3.5GHz)
2. Spectrum analyzer setting P(Peak): RBW=1MHz, VBW=1MHz, A(Average): RBW=1MHz, VBW=10Hz
3. The result basic equation calculation is as follow:

$$\text{Level} = \text{Reading} + \text{AF} + \text{Cable} - \text{Preamp} + \text{Filter} - \text{Dist}, \text{Margin} = \text{Level} - \text{Limit}$$
4. The other emission levels were 20dB below the limit
5. The test limit distance is 3M limit.



Product Name	AirCruiser Extreme N Router	Test Date	2009/3/23
Model	GN-BR33V-RH	Test By	Eric Yang
Test Mode	IEEE 802.11n HT40 TX (CH Low)	TEMP& Humidity	28.1°C, 52%

Horizontal

TX / IEEE 802.11n HT40 mode / CH Low				Measurement Distance at 3m				Horizontal polarity		
Freq.	Reading	AF	Cable Loss	Pre-amp	Filter	Level	Limit	Margin	Mark	
(MHz)	(dBμV)	(dB/m)	(dB)	(dB)	(dB)	(dBμV/m)	(dBμV/m)	(dB)	(P/Q/A)	
2432.23	105.32	30.04	2.34	39.77	0.00	97.93	Fundamental Frequency		P	
2432.23	98.25	30.04	2.34	39.77	0.00	90.86			A	
3229.28	50.24	30.04	2.79	40.23	1.24	44.08	77.93	-33.85	P	
3229.28	44.31	30.04	2.79	40.23	1.24	38.15	70.86	-32.71	A	
* 4842.65	50.11	32.85	3.72	41.36	0.70	46.02	74.00	-27.98	P	
* 4842.65	39.75	32.85	3.72	41.36	0.70	35.66	54.00	-18.34	A	
* 7257.28	60.32	38.86	4.94	41.39	1.48	64.20	74.00	-9.80	P	
* 7257.28	45.36	38.86	4.94	41.39	1.48	49.24	54.00	-4.76	A	
N/A	-----	-----	-----	-----	-----	-----	-----	-----	P	
N/A	-----	-----	-----	-----	-----	-----	-----	-----	A	

REMARK:

1. AF: Antenna Factor, Cable: Cable Loss, Pre-Amp: Preamplifier gain, Filter: High Pass Filter Insertion Loss (3.5GHz)
2. Spectrum analyzer setting P(Peak): RBW=1MHz, VBW=1MHz, A(Average): RBW=1MHz, VBW=10Hz
3. The result basic equation calculation is as follow:

$$\text{Level} = \text{Reading} + \text{AF} + \text{Cable} - \text{Preamp} + \text{Filter} - \text{Dist}, \text{Margin} = \text{Level} - \text{Limit}$$
4. The other emission levels were 20dB below the limit
5. The test limit distance is 3M limit.



Product Name	AirCruiser Extreme N Router	Test Date	2009/3/23
Model	GN-BR33V-RH	Test By	Eric Yang
Test Mode	IEEE 802.11n HT40 TX (CH Low)	TEMP& Humidity	28.1°C, 52%

Vertical

TX / IEEE 802.11n HT40 mode / CH Low				Measurement Distance at 3m				Vertical polarity		
Freq.	Reading	AF	Cable Loss	Pre-amp	Filter	Level	Limit	Margin	Mark	
(MHz)	(dBμV)	(dB/m)	(dB)	(dB)	(dB)	(dBμV/m)	(dBμV/m)	(dB)	(P/Q/A)	
2423.87	115.53	30.05	2.34	39.78	0.00	108.13	Fundamental Frequency		P	
2423.87	106.17	30.05	2.34	39.78	0.00	98.77			A	
3229.33	52.82	30.04	2.79	40.23	1.24	46.66	88.13	-41.47	P	
3229.33	46.82	30.04	2.79	40.23	1.24	40.66	78.77	-38.11	A	
* 4843.65	52.42	32.86	3.72	41.37	0.70	48.33	74.00	-25.67	P	
* 4843.65	41.33	32.86	3.72	41.37	0.70	37.24	54.00	-16.76	A	
* 7257.34	63.24	38.86	4.94	41.39	1.48	67.12	74.00	-6.88	P	
* 7257.34	48.74	38.86	4.94	41.39	1.48	52.62	54.00	-1.38	A	
N/A	-----	-----	-----	-----	-----	-----	-----	-----	P	
N/A	-----	-----	-----	-----	-----	-----	-----	-----	A	

REMARK:

1. AF: Antenna Factor, Cable: Cable Loss, Pre-Amp: Preamplifier gain, Filter: High Pass Filter Insertion Loss (3.5GHz)
2. Spectrum analyzer setting P(Peak): RBW=1MHz, VBW=1MHz, A(Average): RBW=1MHz, VBW=10Hz
3. The result basic equation calculation is as follow:

$$\text{Level} = \text{Reading} + \text{AF} + \text{Cable} - \text{Preamp} + \text{Filter} - \text{Dist}, \text{Margin} = \text{Level} - \text{Limit}$$
4. The other emission levels were 20dB below the limit
5. The test limit distance is 3M limit.



Product Name	AirCruiser Extreme N Router	Test Date	2009/3/23
Model	GN-BR33V-RH	Test By	Eric Yang
Test Mode	IEEE 802.11n HT40 TX (CH Middle)	TEMP& Humidity	28.1 °C, 52%

Horizontal

TX / IEEE 802.11n HT40 mode / CH Middle				Measurement Distance at 3m				Horizontal polarity		
Freq.	Reading	AF	Cable Loss	Pre-amp	Filter	Level	Limit	Margin	Mark	
(MHz)	(dBμV)	(dB/m)	(dB)	(dB)	(dB)	(dBμV/m)	(dBμV/m)	(dB)	(P/Q/A)	
2447.22	105.82	30.03	2.34	39.76	0.00	98.43	Fundamental Frequency		P	
2447.22	97.35	30.03	2.34	39.76	0.00	89.96			A	
3249.22	49.85	30.05	2.82	40.24	1.22	43.69	78.43	-34.74	P	
3249.22	43.02	30.05	2.82	40.24	1.22	36.86	69.96	-33.10	A	
* 4873.65	49.85	32.92	3.73	41.41	0.71	45.81	74.00	-28.19	P	
* 4873.65	39.25	32.92	3.73	41.41	0.71	35.21	54.00	-18.79	A	
* 7317.65	57.46	38.94	4.96	41.31	1.61	61.67	74.00	-12.33	P	
* 7317.65	45.22	38.94	4.96	41.31	1.61	49.43	54.00	-4.57	A	
N/A	-----	-----	-----	-----	-----	-----	-----	-----	P	
N/A	-----	-----	-----	-----	-----	-----	-----	-----	A	

REMARK:

1. AF: Antenna Factor, Cable: Cable Loss, Pre-Amp: Preamplifier gain, Filter: High Pass Filter Insertion Loss (3.5GHz)
2. Spectrum analyzer setting P(Peak): RBW=1MHz, VBW=1MHz, A(Average): RBW=1MHz, VBW=10Hz
3. The result basic equation calculation is as follow:
Level = Reading + AF + Cable – Preamp + Filter – Dist, Margin = Level-Limit
4. The other emission levels were 20dB below the limit
5. The test limit distance is 3M limit.



Product Name	AirCruiser Extreme N Router	Test Date	2009/3/23
Model	GN-BR33V-RH	Test By	Eric Yang
Test Mode	IEEE 802.11n HT40 TX (CH Middle)	TEMP& Humidity	28.1 °C, 52%

Vertical

TX / IEEE 802.11n HT40 mode / CH Middle				Measurement Distance at 3m Vertical polarity					
Freq.	Reading	AF	Cable Loss	Pre-amp	Filter	Level	Limit	Margin	Mark
(MHz)	(dBμV)	(dB/m)	(dB)	(dB)	(dB)	(dBμV/m)	(dBμV/m)	(dB)	(P/Q/A)
2434.36	114.55	30.04	2.34	39.77	0.00	107.16	Fundamental Frequency		P
2434.36	106.46	30.04	2.34	39.77	0.00	99.07			A
3249.17	51.94	30.05	2.82	40.24	1.22	45.78	87.16	-41.38	P
3249.17	45.57	30.05	2.82	40.24	1.22	39.41	79.07	-39.66	A
* 4874.25	52.56	32.92	3.73	41.41	0.71	48.52	74.00	-25.48	P
* 4874.25	41.35	32.92	3.73	41.41	0.71	37.31	54.00	-16.69	A
* 7318.64	60.06	38.95	4.96	41.31	1.61	64.27	74.00	-9.73	P
* 7318.64	48.00	38.95	4.96	41.31	1.61	52.21	54.00	-1.79	A
N/A	-----	-----	-----	-----	-----	-----	-----	-----	P
N/A	-----	-----	-----	-----	-----	-----	-----	-----	A

REMARK:

1. AF: Antenna Factor, Cable: Cable Loss, Pre-Amp: Preamplifier gain, Filter: High Pass Filter Insertion Loss (3.5GHz)
2. Spectrum analyzer setting P(Peak): RBW=1MHz, VBW=1MHz, A(Average): RBW=1MHz, VBW=10Hz
3. The result basic equation calculation is as follow:
Level = Reading + AF + Cable – Preamp + Filter – Dist, Margin = Level-Limit
4. The other emission levels were 20dB below the limit
5. The test limit distance is 3M limit.



Product Name	AirCruiser Extreme N Router	Test Date	2009/3/23
Model	GN-BR33V-RH	Test By	Eric Yang
Test Mode	IEEE 802.11n HT40 TX (CH High)	TEMP& Humidity	28.1°C, 52%

Horizontal

TX / IEEE 802.11n HT40 mode / CH High				Measurement Distance at 3m				Horizontal polarity		
Freq.	Reading	AF	Cable Loss	Pre-amp	Filter	Level	Limit	Margin	Mark	
(MHz)	(dBμV)	(dB/m)	(dB)	(dB)	(dB)	(dBμV/m)	(dBμV/m)	(dB)	(P/Q/A)	
2456.63	105.38	30.03	2.34	39.75	0.00	97.99	Fundamental Frequency		P	
2456.63	98.06	30.03	2.34	39.75	0.00	90.67			A	
3269.41	49.85	30.06	2.85	40.26	1.19	43.69	77.99	-34.30	P	
3269.41	43.11	30.06	2.85	40.26	1.19	36.95	70.67	-33.72	A	
* 4902.15	50.14	32.98	3.75	41.45	0.72	46.14	74.00	-27.86	P	
* 4902.15	40.33	32.98	3.75	41.45	0.72	36.33	54.00	-17.67	A	
* 7351.14	60.25	38.99	4.98	41.26	1.68	64.64	74.00	-9.36	P	
* 7351.14	43.75	38.99	4.98	41.26	1.68	48.14	54.00	-5.86	A	
N/A	-----	-----	-----	-----	-----	-----	-----	-----	P	
N/A	-----	-----	-----	-----	-----	-----	-----	-----	A	

REMARK:

1. AF: Antenna Factor, Cable: Cable Loss, Pre-Amp: Preamplifier gain, Filter: High Pass Filter Insertion Loss (3.5GHz)
2. Spectrum analyzer setting P(Peak): RBW=1MHz, VBW=1MHz, A(Average): RBW=1MHz, VBW=10Hz
3. The result basic equation calculation is as follow:
Level = Reading + AF + Cable – Preamp + Filter – Dist, Margin = Level-Limit
4. The other emission levels were 20dB below the limit
5. The test limit distance is 3M limit.



Product Name	AirCruiser Extreme N Router	Test Date	2009/3/23
Model	GN-BR33V-RH	Test By	Eric Yang
Test Mode	IEEE 802.11n HT40 TX (CH High)	TEMP& Humidity	28.1 °C, 52%

Vertical

TX / IEEE 802.11n HT40 mode / CH High				Measurement Distance at 3m			Vertical polarity		
Freq.	Reading	AF	Cable Loss	Pre-amp	Filter	Level	Limit	Margin	Mark
(MHz)	(dBμV)	(dB/m)	(dB)	(dB)	(dB)	(dBμV/m)	(dBμV/m)	(dB)	(P/Q/A)
2458.13	114.77	30.03	2.34	39.75	0.00	107.38	Fundamental Frequency		P
2458.13	106.42	30.03	2.34	39.75	0.00	99.03			A
3269.37	52.32	30.06	2.85	40.26	1.19	46.16	87.38	-41.22	P
3269.37	45.35	30.06	2.85	40.26	1.19	39.19	79.03	-39.84	A
* 4903.74	52.64	32.99	3.75	41.46	0.72	48.64	74.00	-25.36	P
* 4903.74	42.58	32.99	3.75	41.46	0.72	38.58	54.00	-15.42	A
* 7351.20	63.89	38.99	4.98	41.26	1.68	68.28	74.00	-5.72	P
* 7351.20	47.75	38.99	4.98	41.26	1.68	52.14	54.00	-1.86	A
N/A	-----	-----	-----	-----	-----	-----	-----	-----	P
N/A	-----	-----	-----	-----	-----	-----	-----	-----	A

REMARK:

1. AF: Antenna Factor, Cable: Cable Loss, Pre-Amp: Preamplifier gain, Filter: High Pass Filter Insertion Loss (3.5GHz)
2. Spectrum analyzer setting P(Peak): RBW=1MHz, VBW=1MHz, A(Average): RBW=1MHz, VBW=10Hz
3. The result basic equation calculation is as follow:
Level = Reading + AF + Cable – Preamp + Filter – Dist, Margin = Level-Limit
4. The other emission levels were 20dB below the limit
5. The test limit distance is 3M limit.



8.6.4 RESTRICTED BAND EDGES

IEEE 802.11b mode

Channel	Polarity	Freq.(MHz)	Level(dBuV)	Limit(dBuV)	Margin(dB)	Detector
LOW	H	2390	57.9	74	-16.1	Peak
	H	2390	46.45	54	-7.55	Average
	V	2390	64.32	74	-9.68	Peak
	V	2390	50.84	54	-3.16	Average
HIGH	H	2483.5	58	74	-16	Peak
	H	2483.5	46.28	54	-7.72	Average
	V	2483.5	59.49	74	-14.51	Peak
	V	2483.5	47.49	54	-6.51	Average

IEEE 802.11g mode

Channel	Polarity	Freq.(MHz)	Level(dBuV)	Limit(dBuV)	Margin(dB)	Detector
LOW	H	2390	58.25	74	-15.75	Peak
	H	2390	45.96	54	-8.04	Average
	V	2390	65.59	74	-8.41	Peak
	V	2390	49.99	54	-4.01	Average
HIGH	H	2483.5	57.38	74	-16.62	Peak
	H	2483.5	45.58	54	-8.42	Average
	V	2483.5	70.24	74	-3.76	Peak
	V	2483.5	53.03	54	-0.97	Average

**IEEE 802.11n HT20 mode**

Channel	Polarity	Freq.(MHz)	Level(dBuV)	Limit(dBuV)	Margin(dB)	Detector
LOW	H	2390	59.29	74	-14.71	Peak
	H	2390	46.76	54	-7.24	Average
	V	2390	69.42	74	-4.58	Peak
	V	2390	50.3	54	-3.7	Average
HIGH	H	2483.5	58.75	74	-15.25	Peak
	H	2483.5	45.9	54	-8.1	Average
	V	2483.5	64.03	74	-9.97	Peak
	V	2483.5	48.36	54	-5.64	Average

IEEE 802.11n HT40 mode

Channel	Polarity	Freq.(MHz)	Level(dBuV)	Limit(dBuV)	Margin(dB)	Detector
LOW	H	2390	60.85	74	-13.15	Peak
	H	2390	48.47	54	-5.53	Average
	V	2390	66.74	74	-7.26	Peak
	V	2390	52.5	54	-1.5	Average
HIGH	H	2483.5	58.08	74	-15.92	Peak
	H	2483.5	45.68	54	-8.32	Average
	V	2483.5	64.45	74	-9.55	Peak
	V	2483.5	51.52	54	-2.48	Average

Detector mode : Peak

Polarity : Horizontal

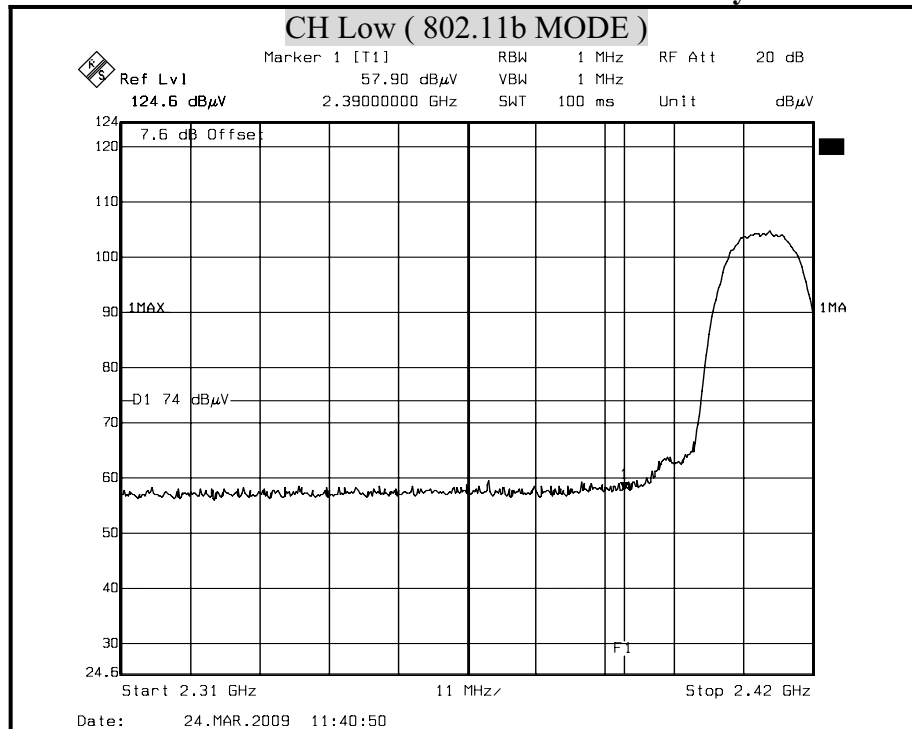

Detector mode : Average

Polarity : Horizontal

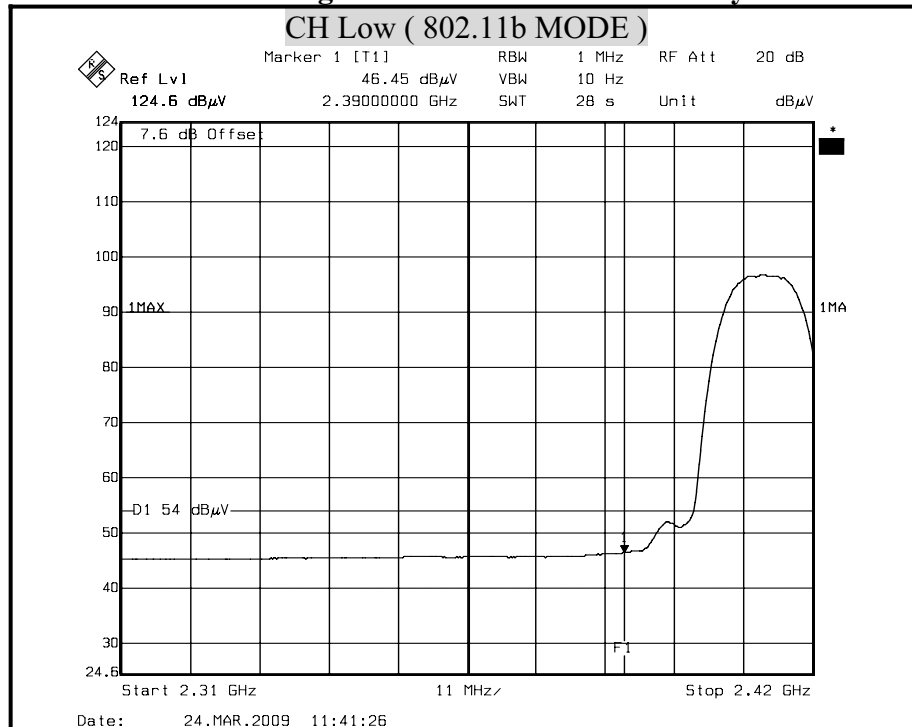

Remark:

1. Display Line = 54/74 dB μ V/m.
2. 2390MHz Offset(dB) = Antenna Factor(dB/m) + Cable Loss(dB) - Pre-Amplifier(dB) + Attenuator(dB)=7.6(dB)
3. 2483.5MHz Offset(dB) = Antenna Factor(dB/m) + Cable Loss(dB) - Pre-Amplifier(dB) + Attenuator(dB)=7.62(dB)

Detector mode : Peak

Polarity : Vertical

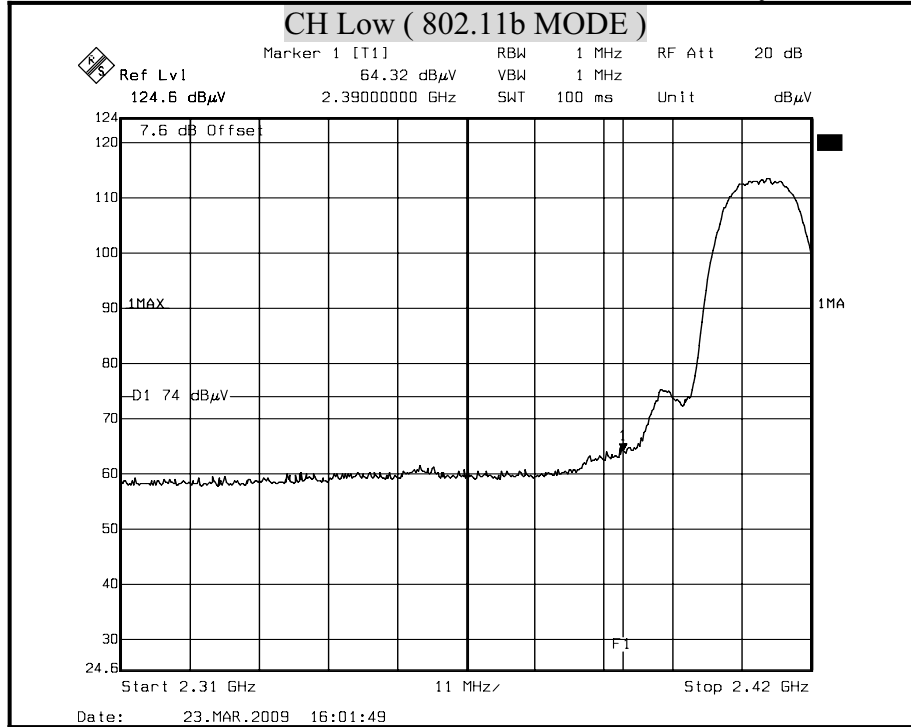

Detector mode : Average

Polarity : Vertical

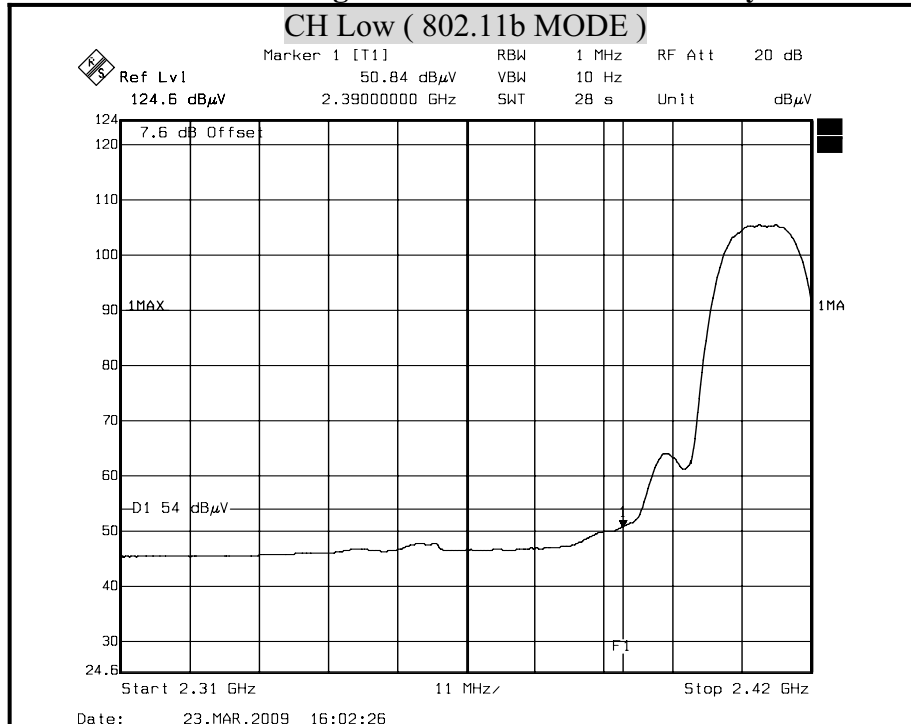

Remark:

1. Display Line = 54/74 dB μ V/m.
2. 2390MHz Offset(dB) = Antenna Factor(dB/m) + Cable Loss(dB) - Pre-Amplifier(dB) + Attenuator(dB)=7.6(dB)
3. 2483.5MHz Offset(dB) = Antenna Factor(dB/m) + Cable Loss(dB) - Pre-Amplifier(dB) + Attenuator(dB)=7.62(dB)

Detector mode : Peak **Polarity : Horizontal**

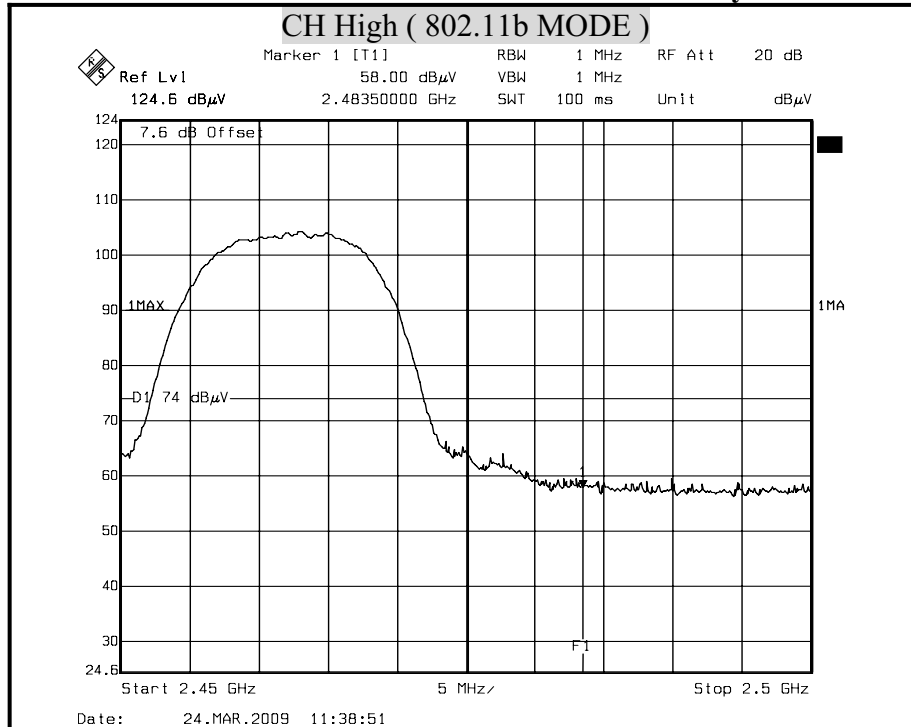

Detector mode : Average **Polarity : Horizontal**

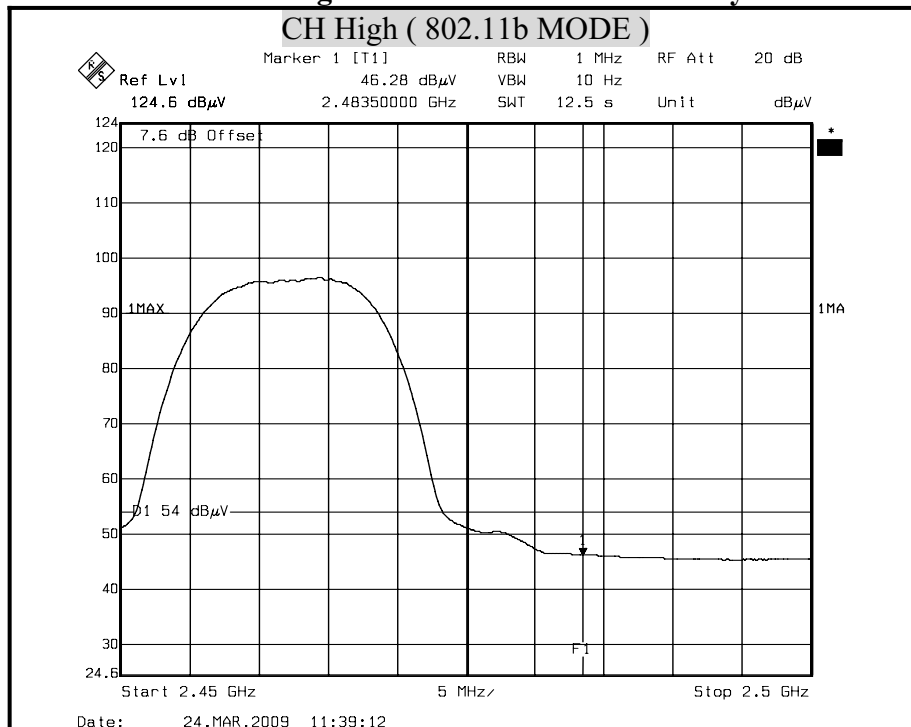

Remark:

1. Display Line = 54/74 dB μ V/m.
2. 2390MHz Offset(dB) = Antenna Factor(dB/m) + Cable Loss(dB) - Pre-Amplifier(dB) + Attenuator(dB)=7.6(dB)
3. 2483.5MHz Offset(dB) = Antenna Factor(dB/m) + Cable Loss(dB) - Pre-Amplifier(dB) + Attenuator(dB)=7.62(dB)

Detector mode : Peak

Polarity : Vertical

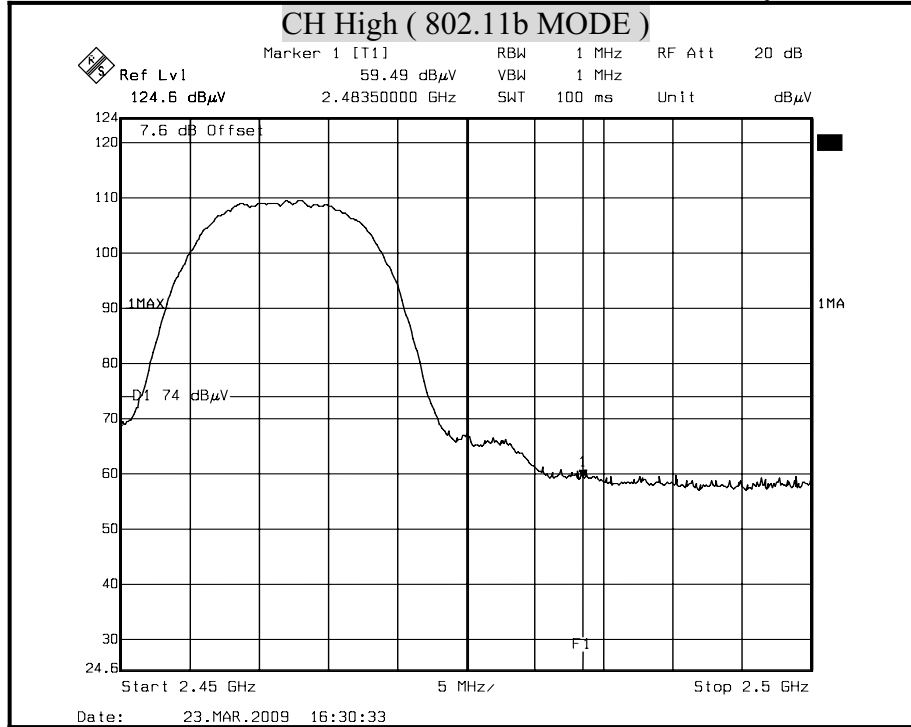

Detector mode : Average

Polarity : Vertical

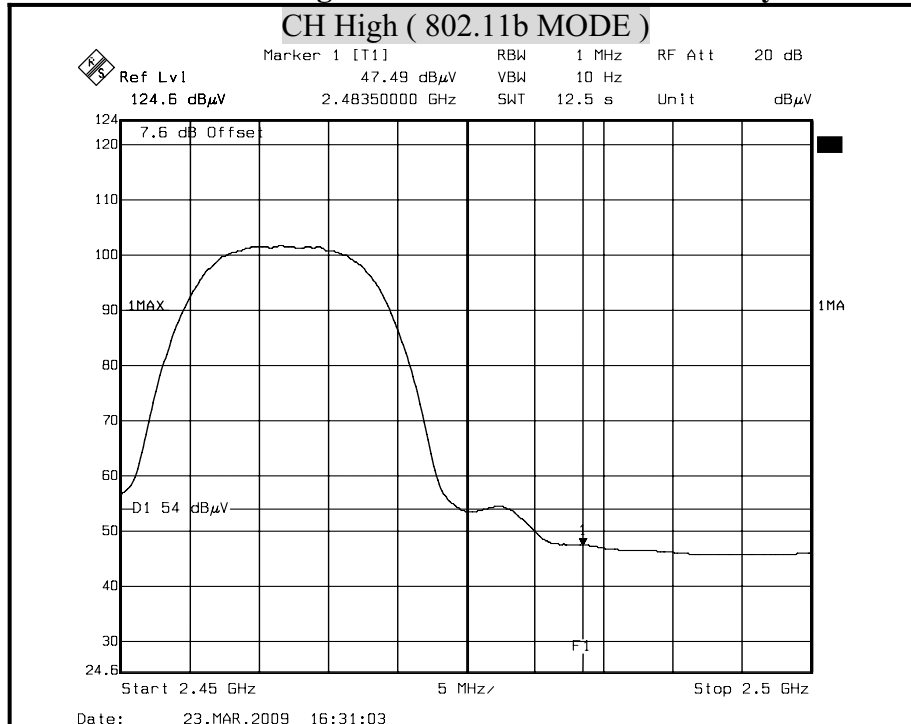

Remark:

1. Display Line = 54/74 dB μ V/m.
2. 2390MHz Offset(dB) = Antenna Factor(dB/m) + Cable Loss(dB) - Pre-Amplifier(dB) + Attenuator(dB)=7.6(dB)
3. 2483.5MHz Offset(dB) = Antenna Factor(dB/m) + Cable Loss(dB) - Pre-Amplifier(dB) + Attenuator(dB)=7.62(dB)



Detector mode : Peak **Polarity : Horizontal**

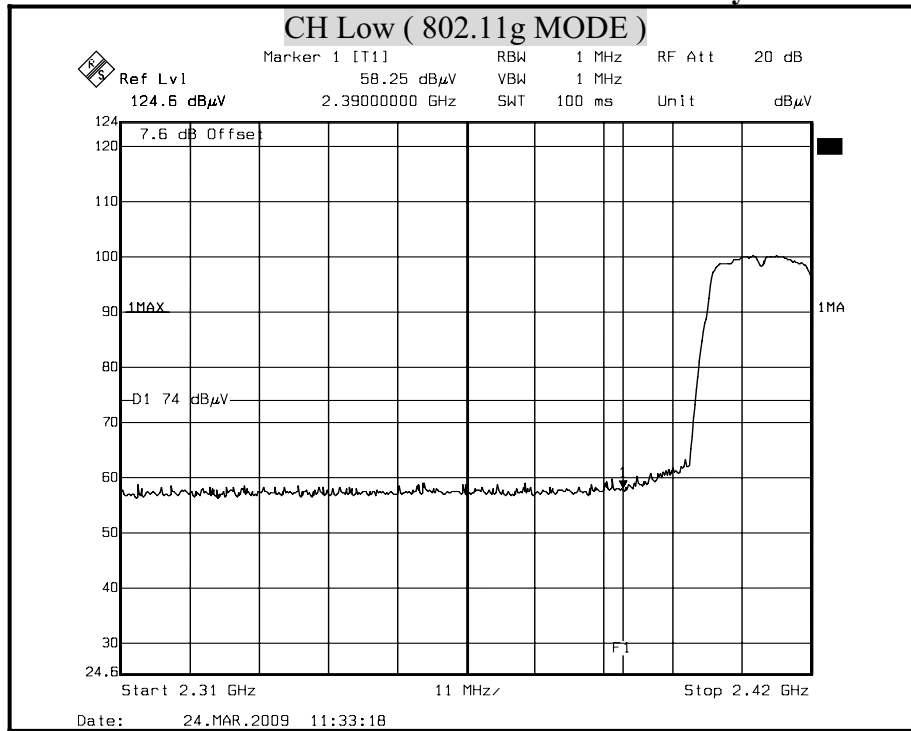

Detector mode : Average **Polarity : Horizontal**

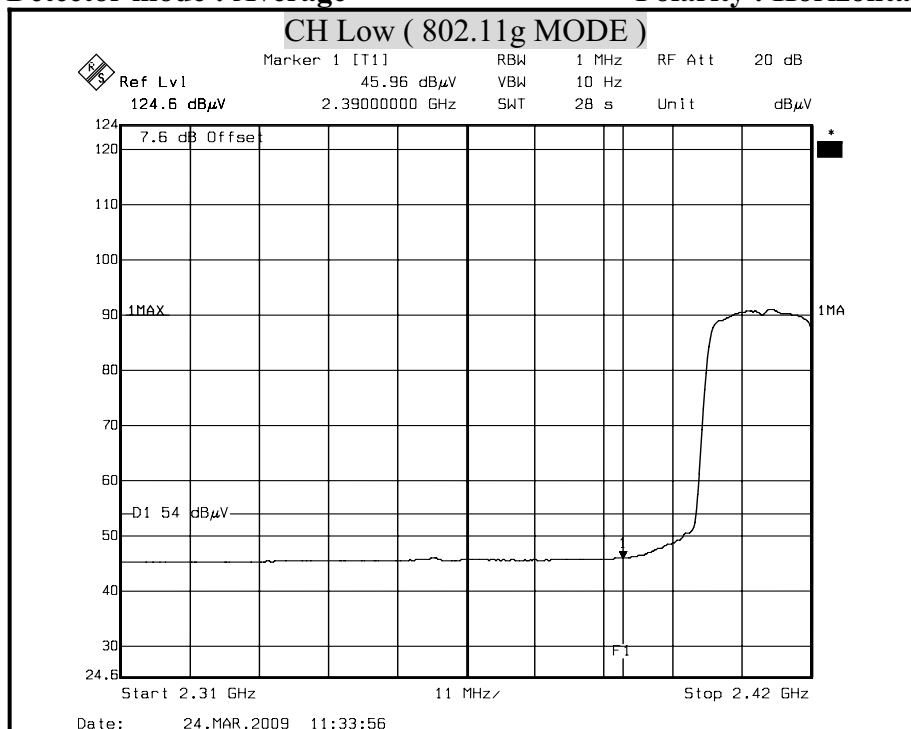

Remark:

1. Display Line = 54/74 dB μ V/m.
2. 2390MHz Offset(dB) = Antenna Factor(dB/m) + Cable Loss(dB) - Pre-Amplifier(dB) + Attenuator(dB)=7.6(dB)
3. 2483.5MHz Offset(dB) = Antenna Factor(dB/m) + Cable Loss(dB) - Pre-Amplifier(dB) + Attenuator(dB)=7.62(dB)



Detector mode : Peak

Polarity : Vertical

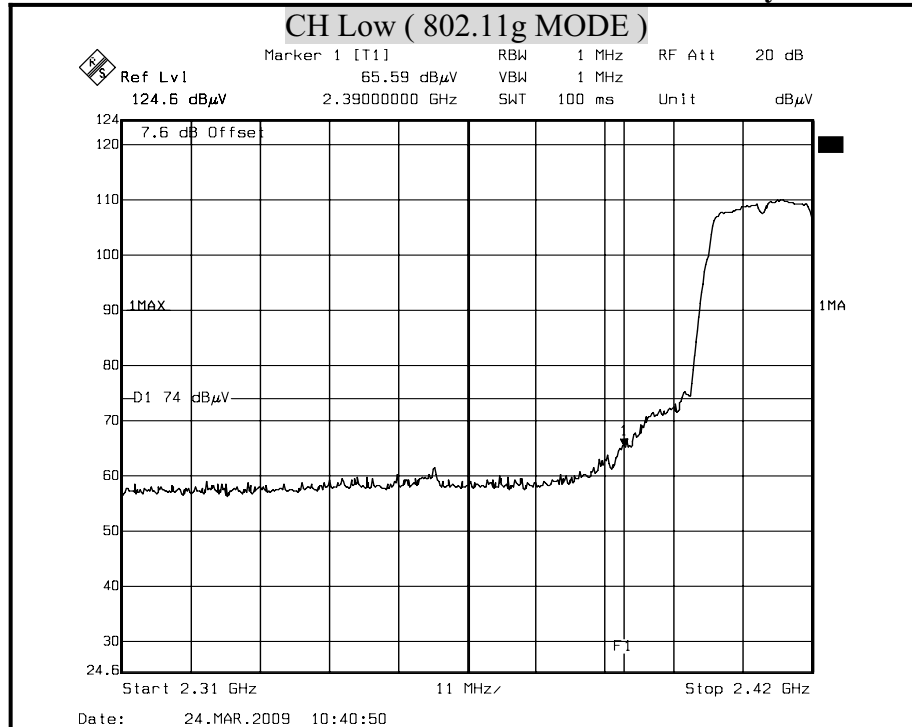

Detector mode : Average

Polarity : Vertical

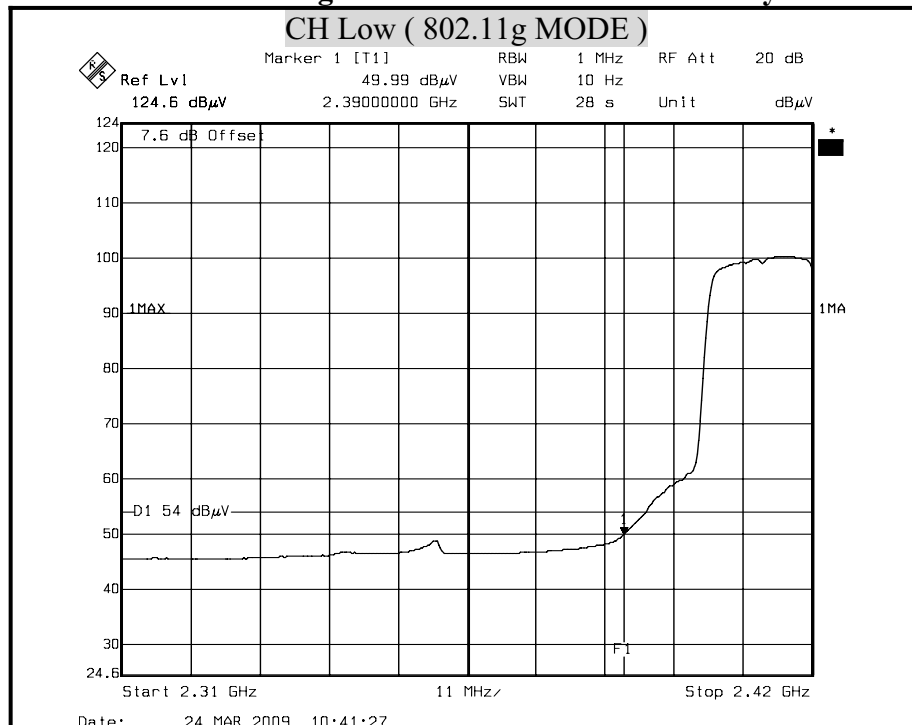

Remark:

1. Display Line = 54/74 dB μ V/m.
2. 2390MHz Offset(dB) = Antenna Factor(dB/m) + Cable Loss(dB) - Pre-Amplifier(dB) + Attenuator(dB)=7.6(dB)
3. 2483.5MHz Offset(dB) = Antenna Factor(dB/m) + Cable Loss(dB) - Pre-Amplifier(dB) + Attenuator(dB)=7.62(dB)

Detector mode : Peak **Polarity : Horizontal**

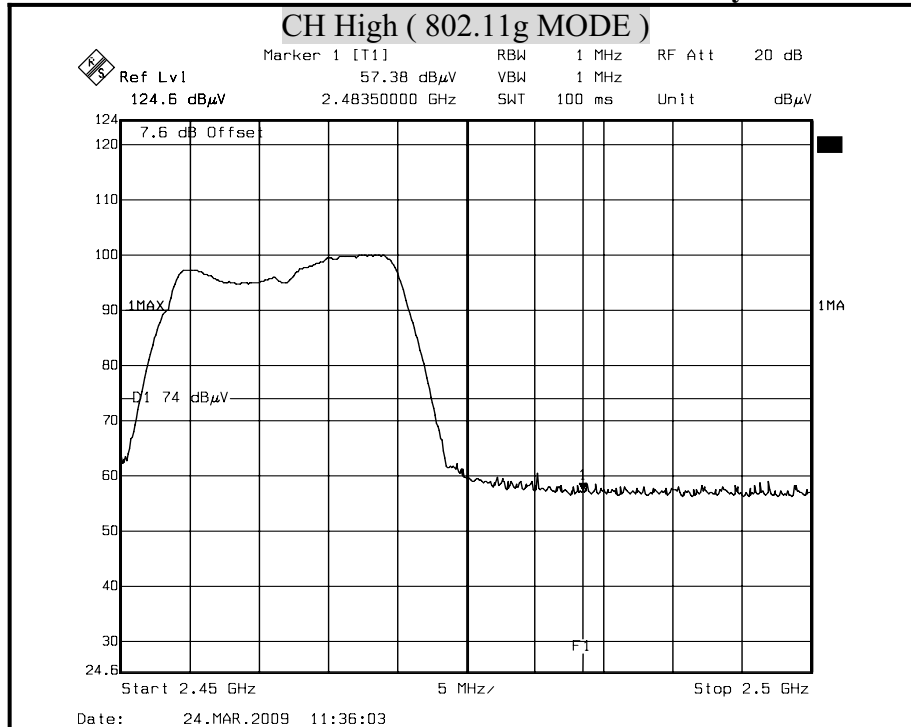

Detector mode : Average **Polarity : Horizontal**

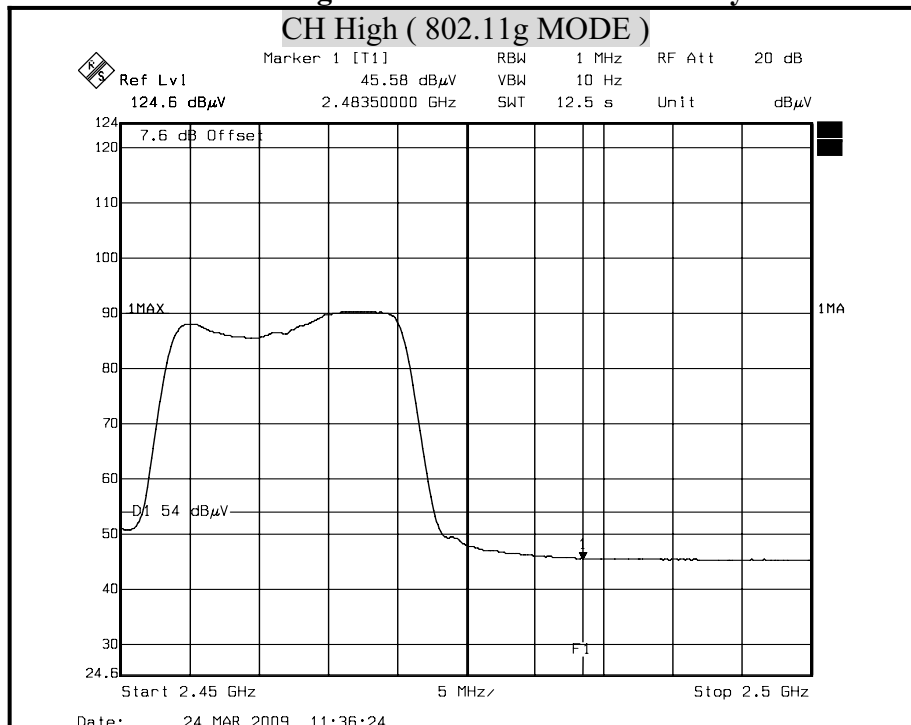

Remark:

1. Display Line = 54/74 dB μ V/m.
2. 2390MHz Offset(dB) = Antenna Factor(dB/m) + Cable Loss(dB) - Pre-Amplifier(dB) + Attenuator(dB)=7.6(dB)
3. 2483.5MHz Offset(dB) = Antenna Factor(dB/m) + Cable Loss(dB) - Pre-Amplifier(dB) + Attenuator(dB)=7.62(dB)

Detector mode : Peak **Polarity : Vertical**

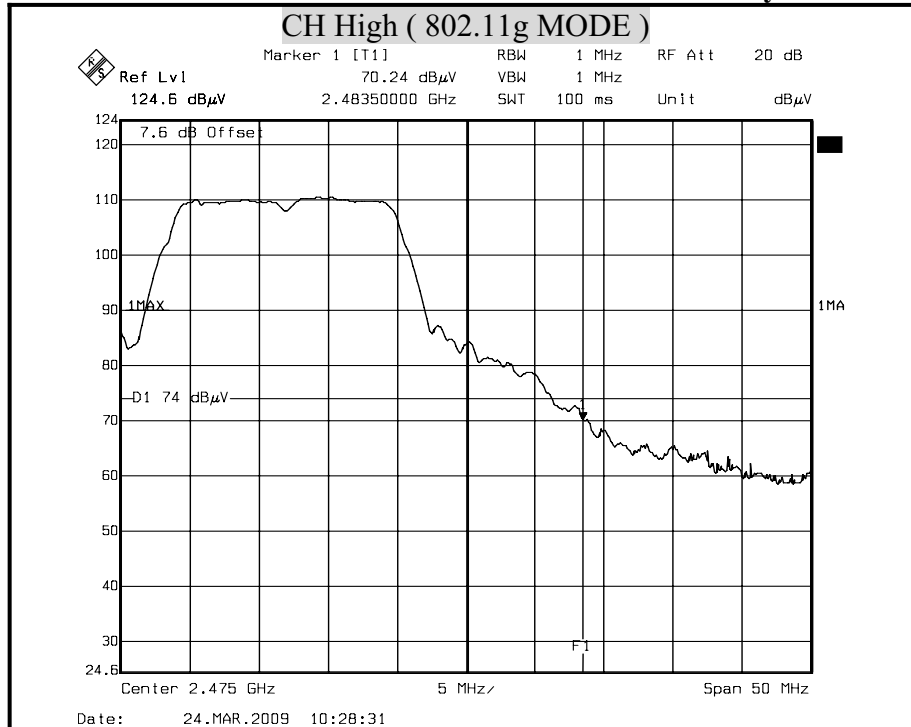

Detector mode : Average **Polarity : Vertical**

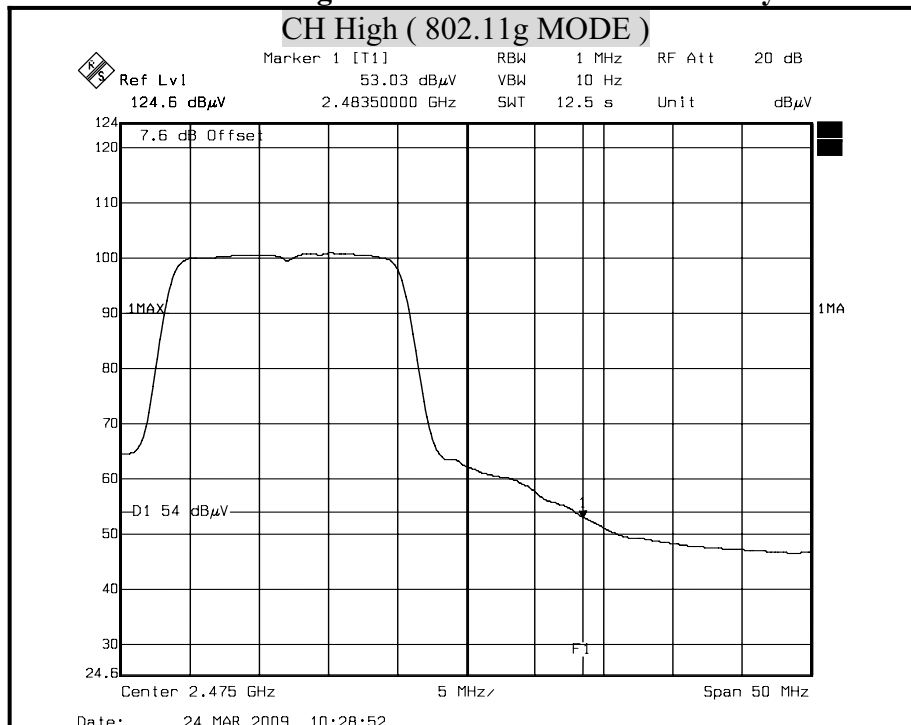

Remark:

1. Display Line = 54/74 dB μ V/m.
2. 2390MHz Offset(dB) = Antenna Factor(dB/m) + Cable Loss(dB) - Pre-Amplifier(dB) + Attenuator(dB)=7.6(dB)
3. 2483.5MHz Offset(dB) = Antenna Factor(dB/m) + Cable Loss(dB) - Pre-Amplifier(dB) + Attenuator(dB)=7.62(dB)



Detector mode : Peak Polarity : Horizontal

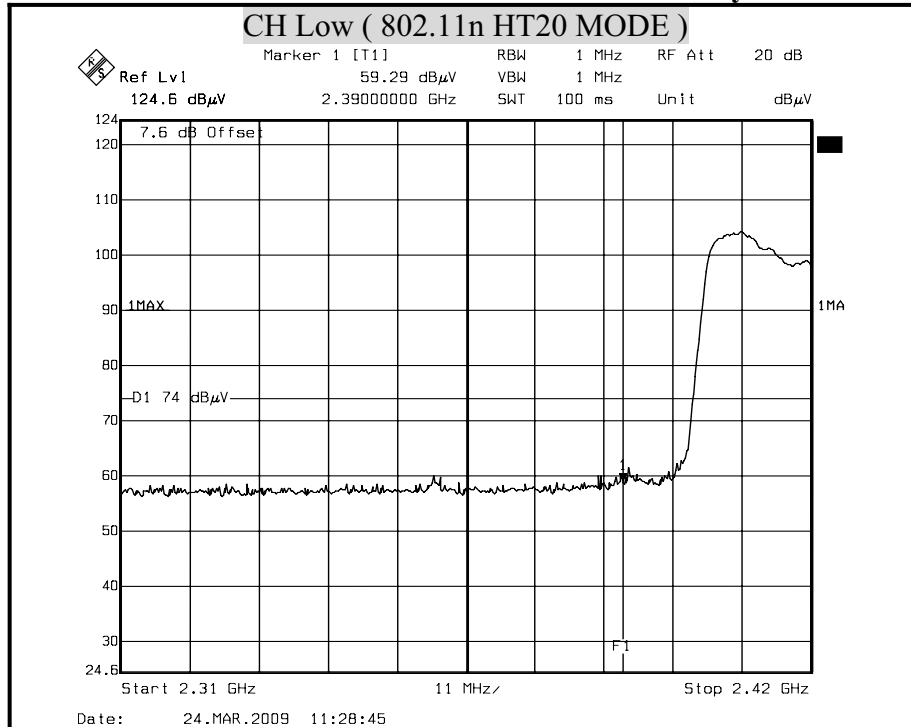

Detector mode : Average Polarity : Horizontal

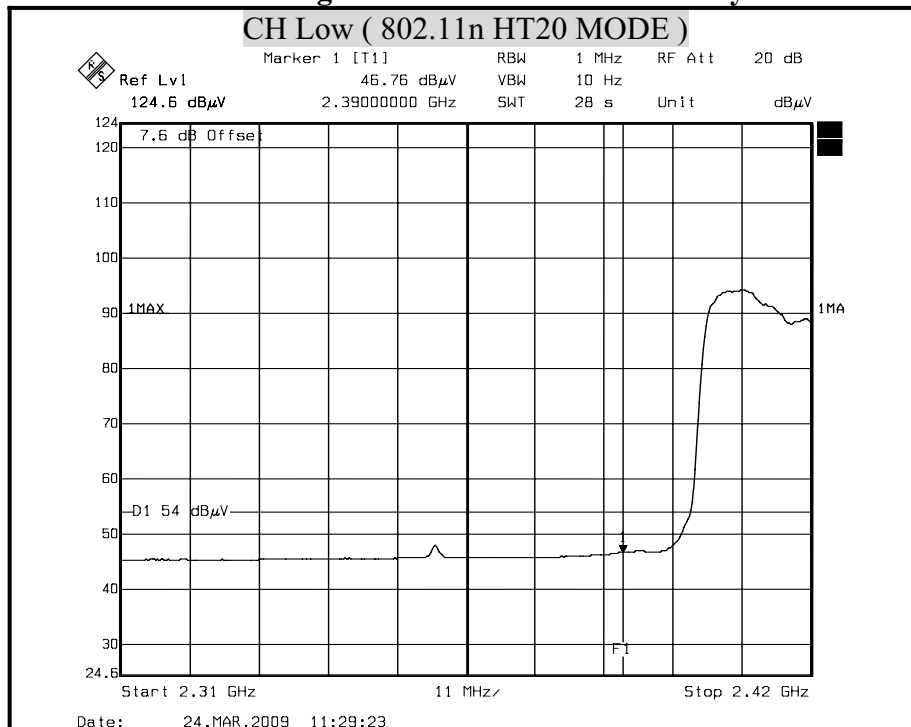

Remark:

1. Display Line = 54/74 dB μ V/m.
2. 2390MHz Offset(dB) = Antenna Factor(dB/m) + Cable Loss(dB) - Pre-Amplifier(dB) + Attenuator(dB)=7.6(dB)
3. 2483.5MHz Offset(dB) = Antenna Factor(dB/m) + Cable Loss(dB) - Pre-Amplifier(dB) + Attenuator(dB)=7.62(dB)



Detector mode : Peak Polarity : Vertical

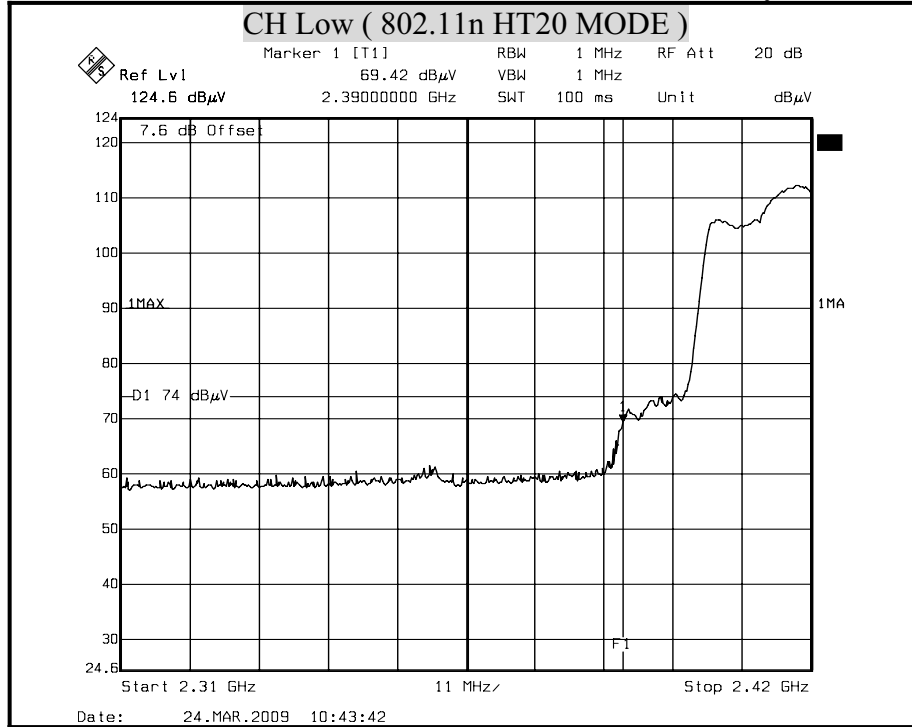

Detector mode : Average Polarity : Vertical

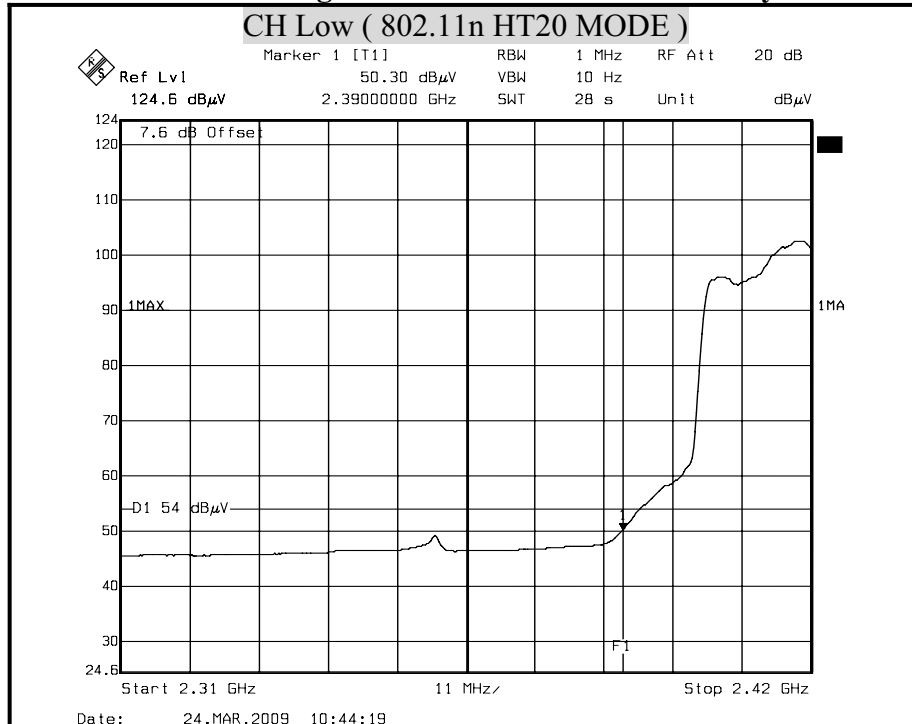

Remark:

1. Display Line = 54/74 dB μ V/m.
2. 2390MHz Offset(dB) = Antenna Factor(dB/m) + Cable Loss(dB) - Pre-Amplifier(dB) + Attenuator(dB)=7.6(dB)
3. 2483.5MHz Offset(dB) = Antenna Factor(dB/m) + Cable Loss(dB) - Pre-Amplifier(dB) + Attenuator(dB)=7.62(dB)

Detector mode : Peak **Polarity : Horizontal**

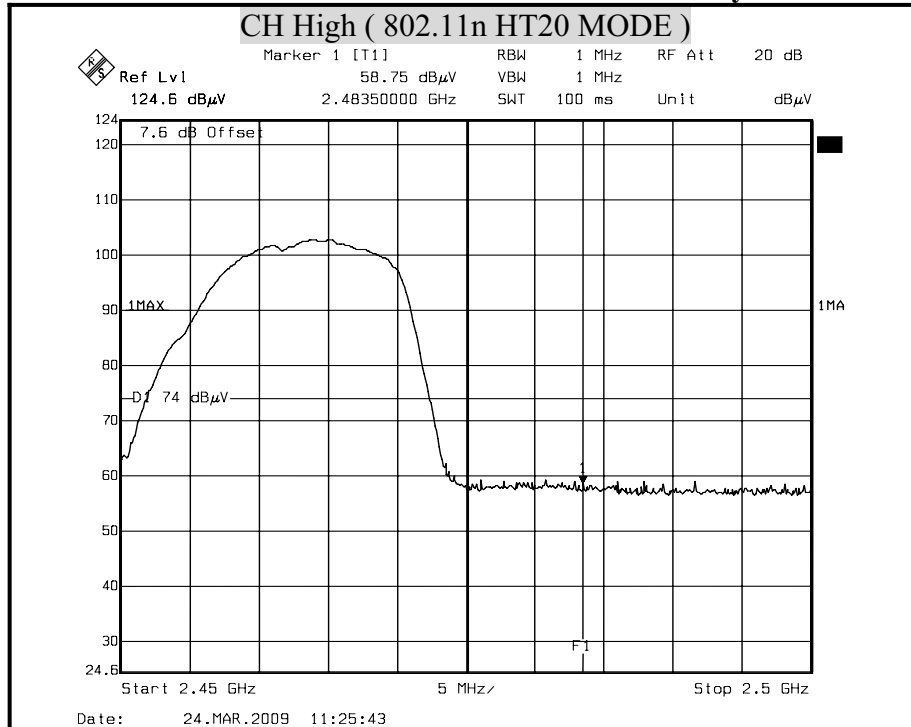

Detector mode : Average **Polarity : Horizontal**

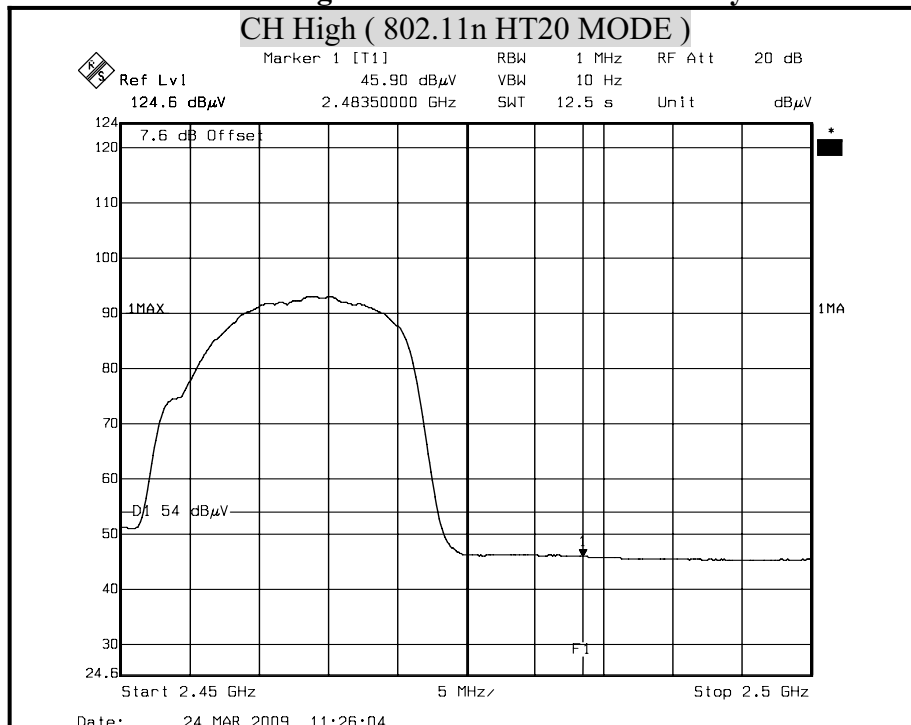

Remark:

1. Display Line = 54/74 dB μ V/m.
2. 2390MHz Offset(dB) = Antenna Factor(dB/m) + Cable Loss(dB) - Pre-Amplifier(dB) + Attenuator(dB)=7.6(dB)
3. 2483.5MHz Offset(dB) = Antenna Factor(dB/m) + Cable Loss(dB) - Pre-Amplifier(dB) + Attenuator(dB)=7.62(dB)

Detector mode : Peak **Polarity : Vertical**

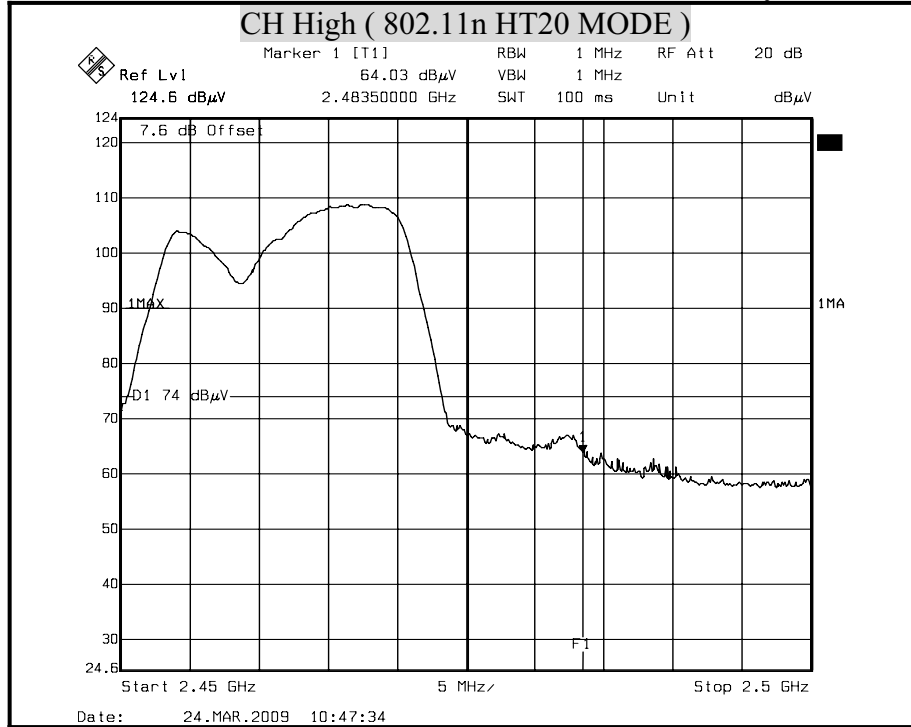

Detector mode : Average **Polarity : Vertical**

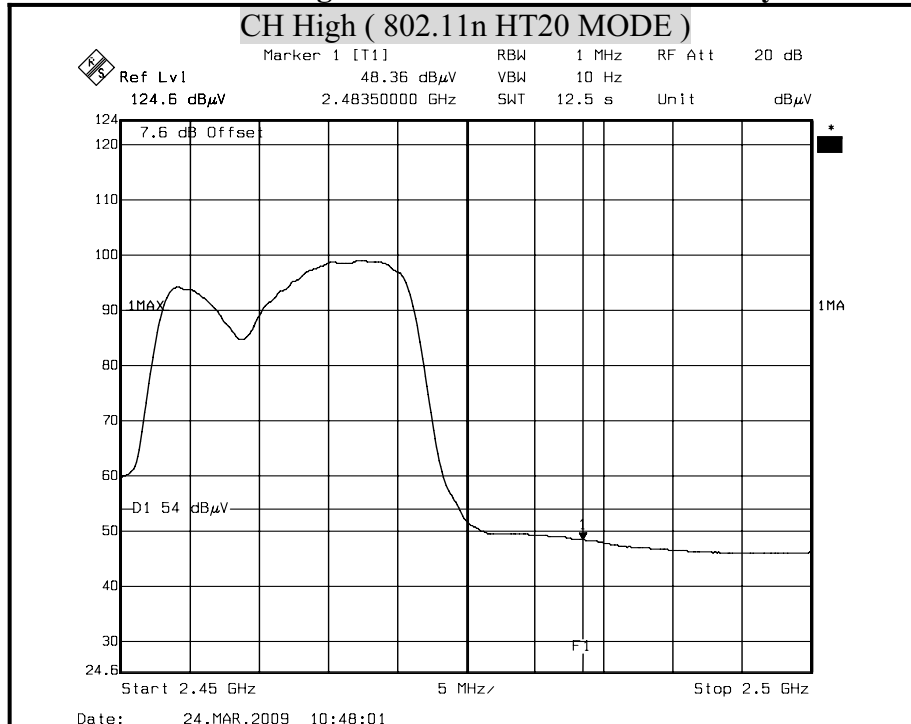

Remark:

1. Display Line = 54/74 dB μ V/m.
2. 2390MHz Offset(dB) = Antenna Factor(dB/m) + Cable Loss(dB) - Pre-Amplifier(dB) + Attenuator(dB)=7.6(dB)
3. 2483.5MHz Offset(dB) = Antenna Factor(dB/m) + Cable Loss(dB) - Pre-Amplifier(dB) + Attenuator(dB)=7.62(dB)

Detector mode : Peak **Polarity : Horizontal**

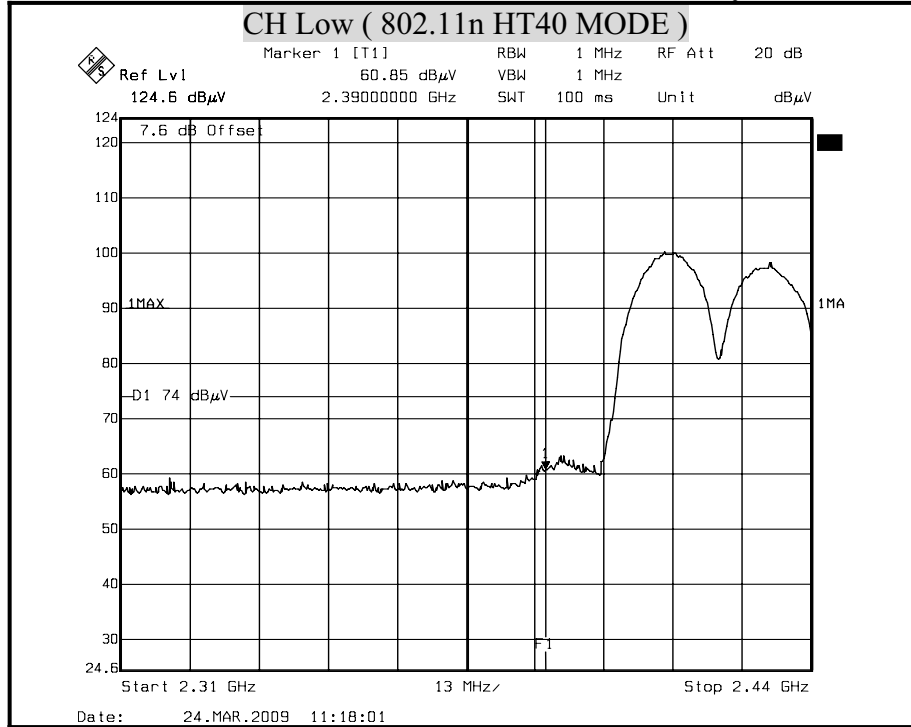

Detector mode : Average **Polarity : Horizontal**

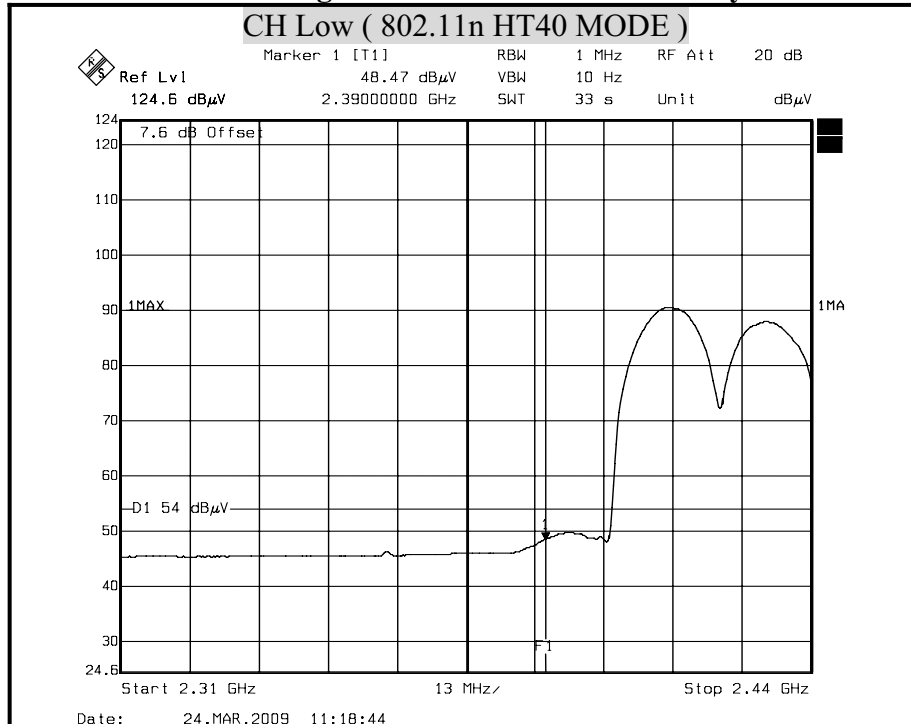

Remark:

1. Display Line = 54/74 dB μ V/m.
2. 2390MHz Offset(dB) = Antenna Factor(dB/m) + Cable Loss(dB) - Pre-Amplifier(dB) + Attenuator(dB)=7.6(dB)
3. 2483.5MHz Offset(dB) = Antenna Factor(dB/m) + Cable Loss(dB) - Pre-Amplifier(dB) + Attenuator(dB)=7.62(dB)



Detector mode : Peak **Polarity : Vertical**

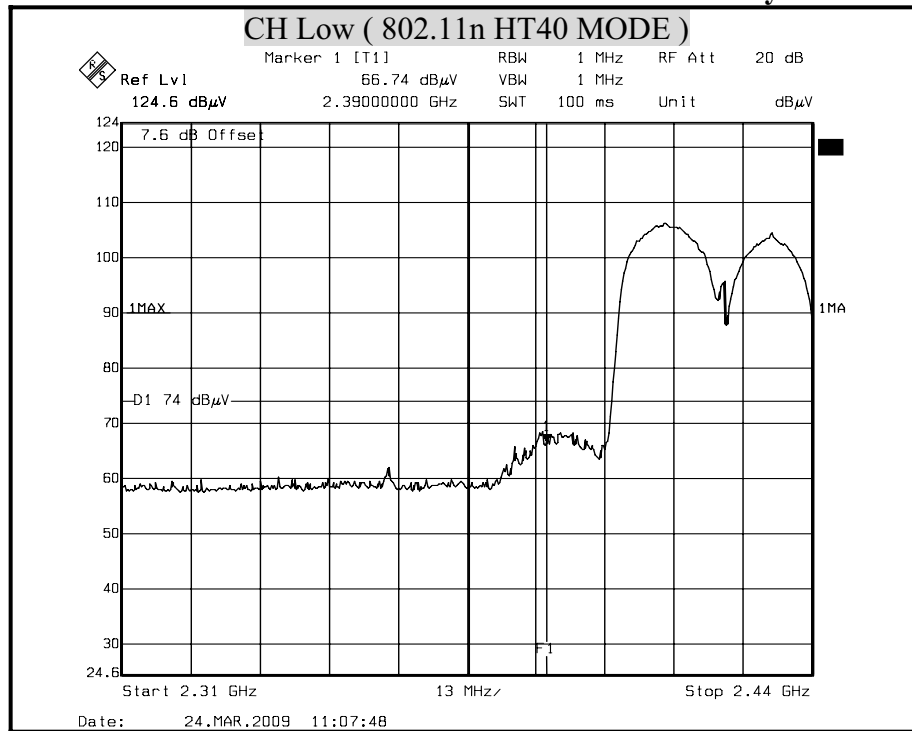

Detector mode : Average **Polarity : Vertical**

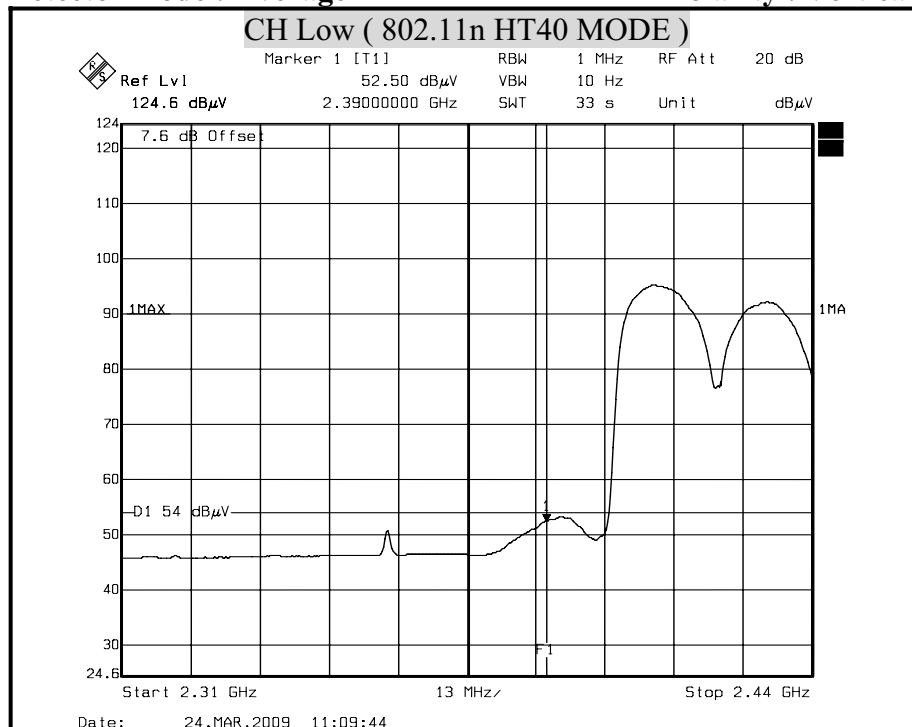

Remark:

1. Display Line = 54/74 dB μ V/m.
2. 2390MHz Offset(dB) = Antenna Factor(dB/m) + Cable Loss(dB) - Pre-Amplifier(dB) + Attenuator(dB)=7.6(dB)
3. 2483.5MHz Offset(dB) = Antenna Factor(dB/m) + Cable Loss(dB) - Pre-Amplifier(dB) + Attenuator(dB)=7.62(dB)

Detector mode : Peak **Polarity : Horizontal**

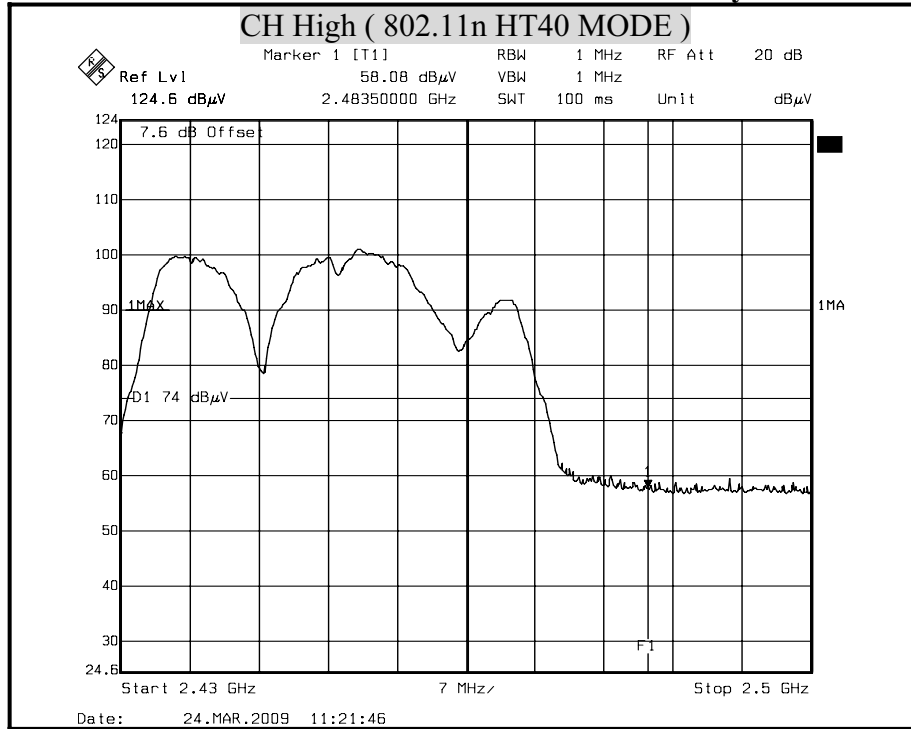

Detector mode : Average **Polarity : Horizontal**

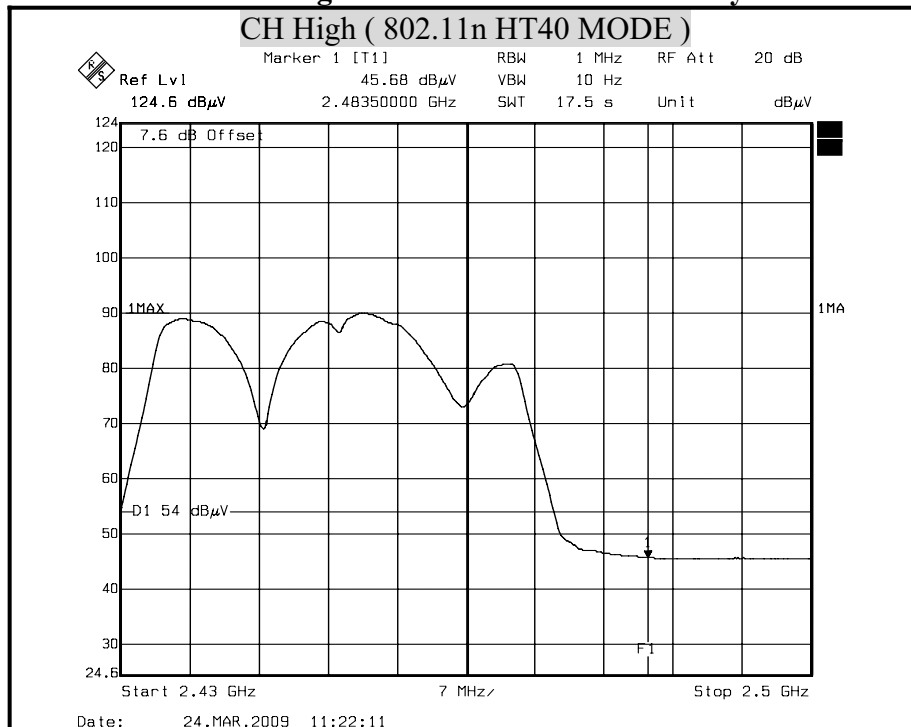

Remark:

1. Display Line = 54/74 dB μ V/m.
2. 2390MHz Offset(dB) = Antenna Factor(dB/m) + Cable Loss(dB) - Pre-Amplifier(dB) + Attenuator(dB)=7.6(dB)
3. 2483.5MHz Offset(dB) = Antenna Factor(dB/m) + Cable Loss(dB) - Pre-Amplifier(dB) + Attenuator(dB)=7.62(dB)

Detector mode : Peak **Polarity : Vertical**

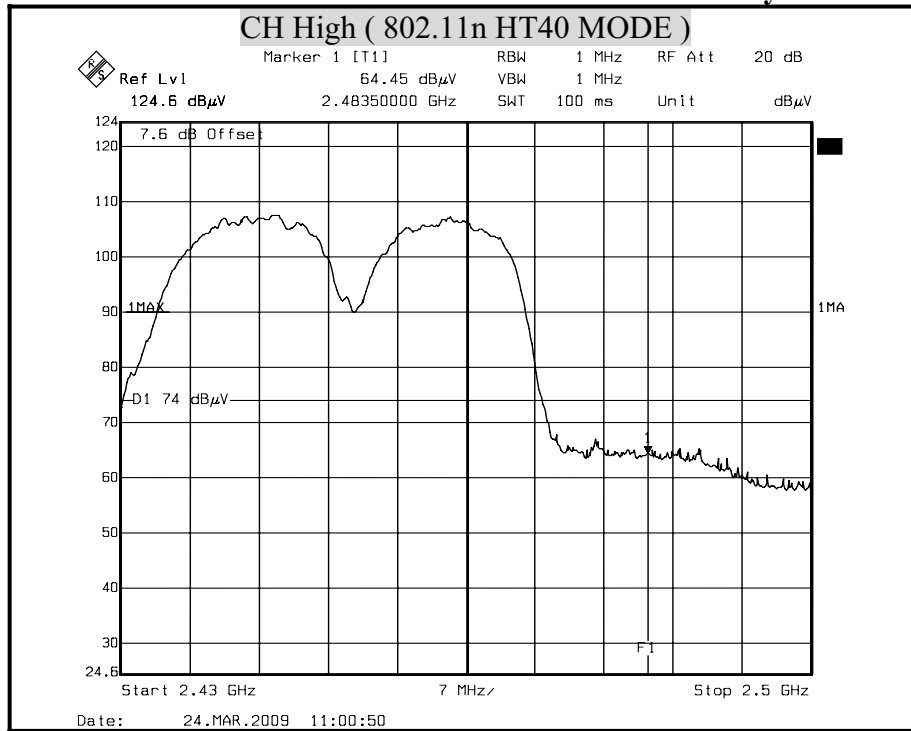

Detector mode : Average **Polarity : Vertical**

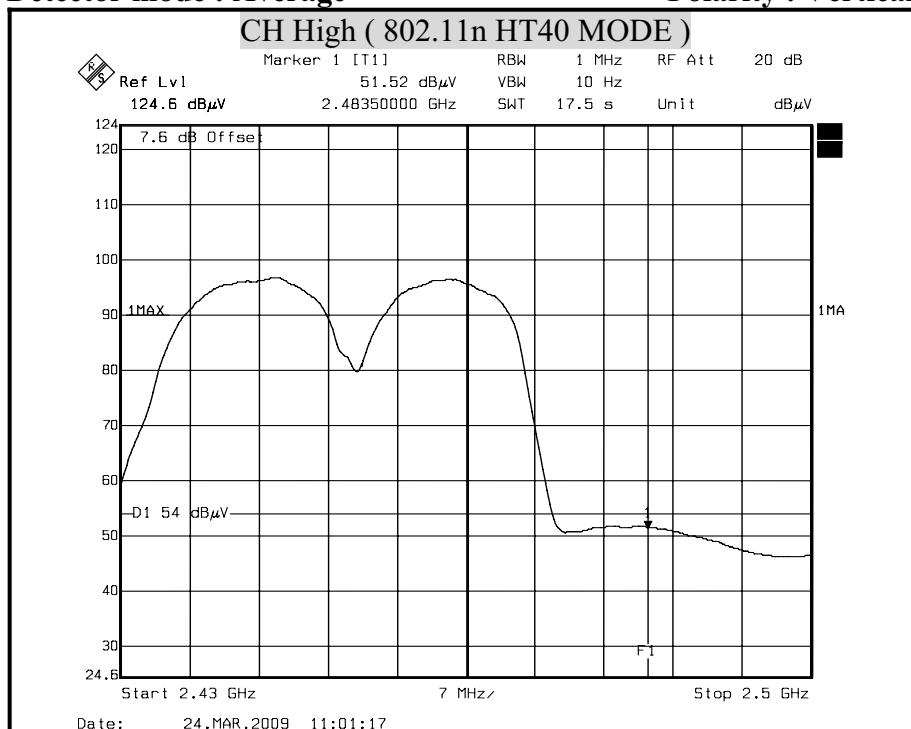

Remark:

1. Display Line = 54/74 dB μ V/m.
2. 2390MHz Offset(dB) = Antenna Factor(dB/m) + Cable Loss(dB) - Pre-Amplifier(dB) + Attenuator(dB)=7.6(dB)
3. 2483.5MHz Offset(dB) = Antenna Factor(dB/m) + Cable Loss(dB) - Pre-Amplifier(dB) + Attenuator(dB)=7.62(dB)

8.7 POWERLINE CONDUCTED EMISSIONS

LIMITS

§ 15.207 (a) Except as shown in paragraph (b) and (c) this section, for an intentional radiator that is designed to be connected to the public utility (AC) power line, the radio frequency voltage that is conducted back onto the AC power line on any frequency or frequencies within the band 150 kHz to 30 MHz shall not exceed the limits in the following table, as measured using a 50 μ H/50 ohms line impedance stabilization network (LISN). Compliance with the provisions of this paragraph shall be based on the measurement of the radio frequency voltage between each power line and ground at the power terminal.

The lower limit applies at the boundary between the frequency ranges.

Frequency of Emission (MHz)	Conducted limit (dB μ v)	
	Quasi-peak	Average
0.15 - 0.5	66 to 56	56 to 46
0.5 - 5	56	46
5 - 30	60	50

TEST EQUIPMENTS

The following test equipments are used during the conducted power line tests:

Conducted Emission room #1				
Name of Equipment	Manufacturer	Model	Serial Number	Calibration Due
L.I.S.N.	SCHWARZBECK	NNLK 8121	8121-446	NOV. 19, 2009 For Insertion loss
	Rohde & Schwarz	ESH 3-Z5	840062/021	OCT. 05, 2009
TEST RECEIVER	Rohde & Schwarz	ESCS 30	100348	JUL. 02, 2009
TYPE N COAXIAL CABLE	SUHNER	BELDEN9913	2981	JAN. 14, 2010
Test S/W	e-3 (5.04211c) R&S (2.27)			

TEST SETUP

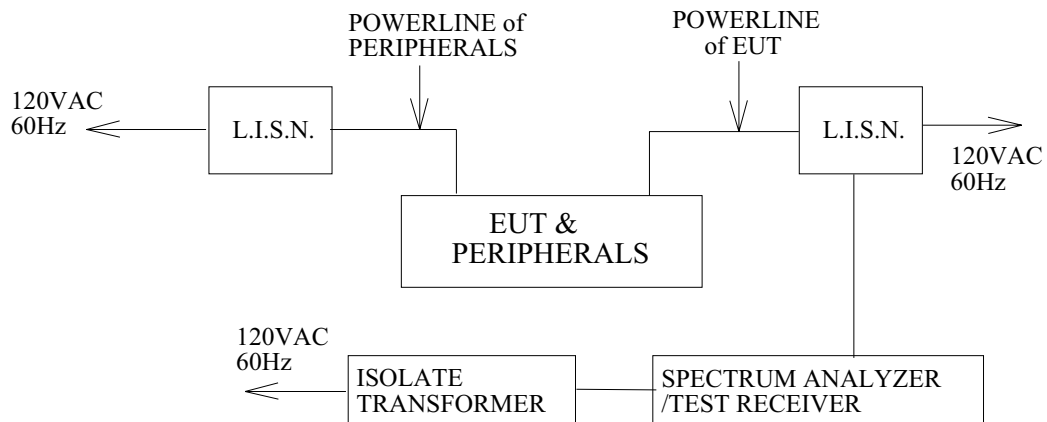

TEST PROCEDURE

The EUT is placed on a non-conducting table 40 cm from the vertical ground plane and 80cm above the horizontal ground plane. The EUT IS CONFIGURED IN ACCORDANCE WITH ANSI C63.4.

The resolution bandwidth is set to 9 kHz for both quasi-peak detection and average detection measurements.

Line conducted data is recorded for both NEUTRAL and LINE.

TEST RESULTS

No non-compliance noted.



CONDUCTED RF VOLTAGE MEASUREMENT

Product Name	AirCruiser Extreme N Router	Test Date	2009/3/18
Model	GN-BR33V-RH	Test By	Taiyu Cyu
Test Mode	Normal operating	TEMP & Humidity	28°C, 59%

LINE

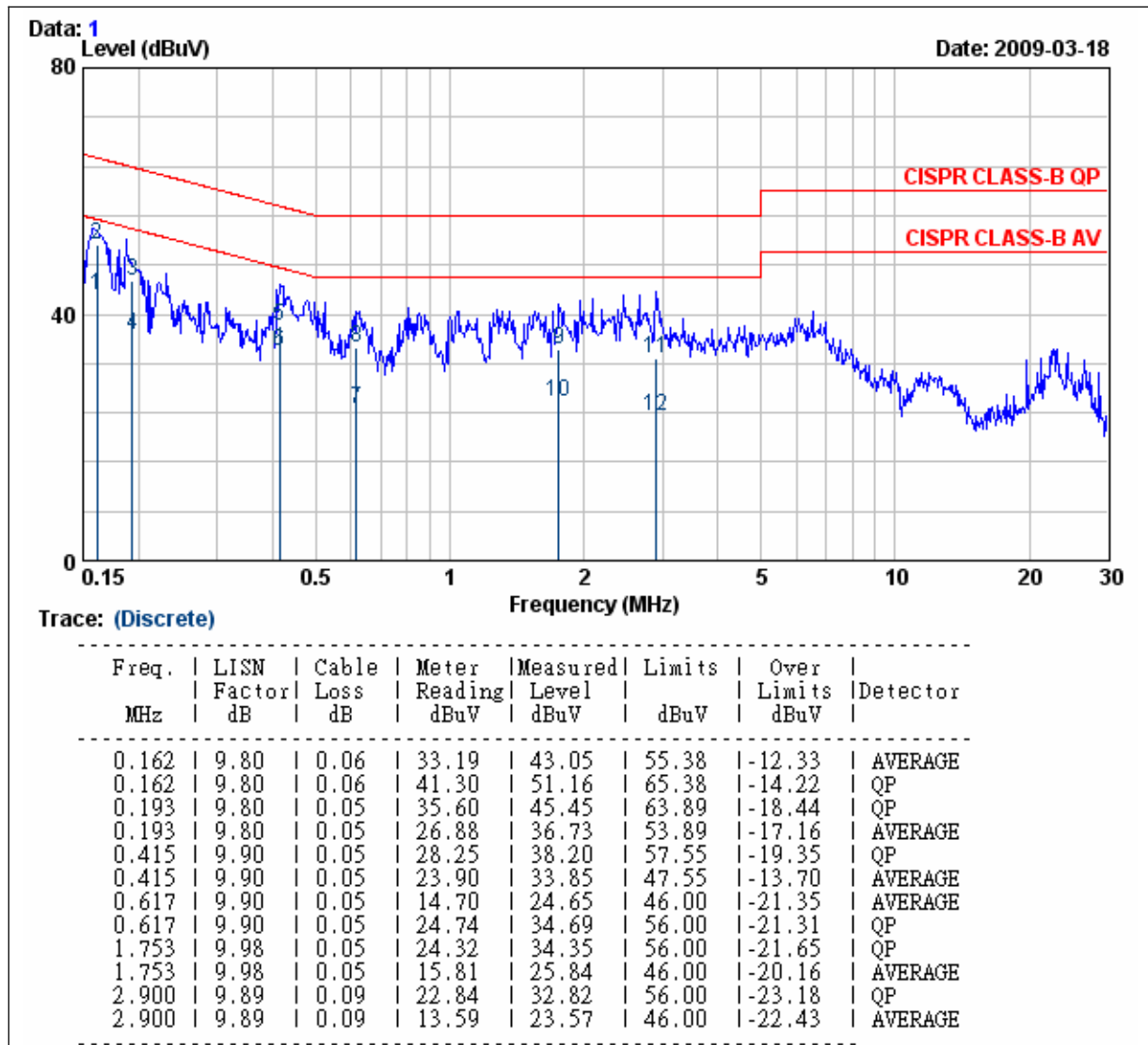

REMARK:

1. Correction Factor = Insertion loss + cable loss
2. Margin value = Emission level – Limit value



Product Name	AirCruiser Extreme N Router	Test Date	2009/3/18
Model	GN-BR33V-RH	Test By	Taiyu Cyu
Test Mode	Normal operating	TEMP & Humidity	28°C, 59%

NEUTRAL

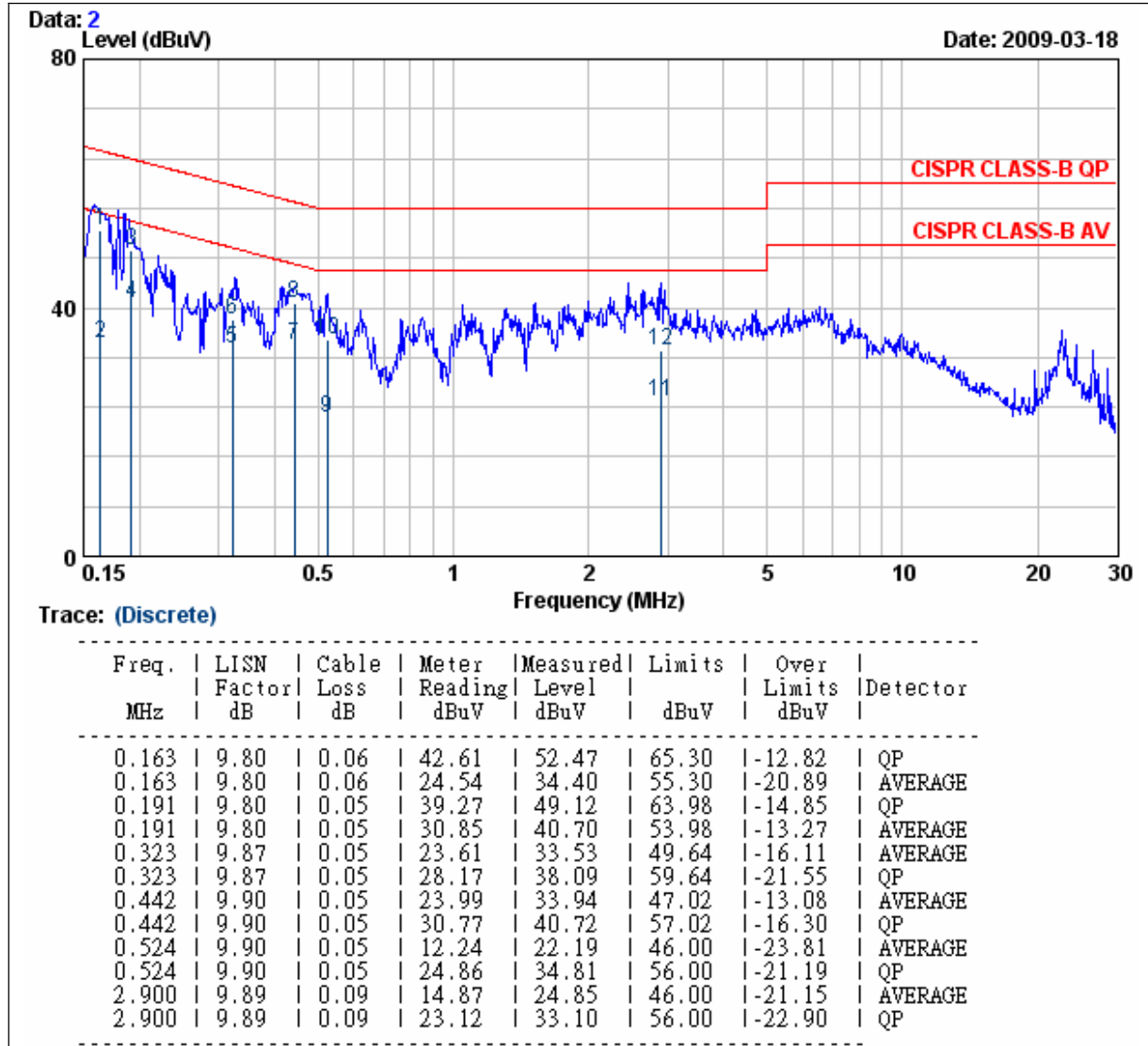

REMARK:

1. Correction Factor = Insertion loss + cable loss
2. Margin value = Emission level – Limit value



9. ANTENNA REQUIREMENT

9.1 STANDARD APPLICABLE

For intentional device, according to FCC 47 CFR Section 15.203, an intentional radiator shall be designed to ensure that no antenna other than that furnished by the responsible party shall be used with the device.

And according to FCC 47 CFR Section 15.247 (b), if transmitting antennas of directional gain greater than 6dBi are used, the power shall be reduced by the amount in dB that the directional gain of the antenna exceeds 6dBi.

9.2 ANTENNA CONNECTED CONSTRUCTION

Dipole Antenna (× 2) 2T2R

Manufacture: ARISTOTLE ENTERPRISES INC.

Model: RFA-02-C14H1-70B120C

Gain: 3.07dBi

Connector: I-PEX