

MEASUREMENT REPORT of *Wireless Router*

Applicant : Well Communication Corp.
EUT : 802.11g Wireless AP
Model No. : WLL-5410R
FCC ID : JCHWLL-5410R
Report No. : W0115687

Tested by :

Training Research Co., Ltd.

TEL : 886-2-26461146

FAX : 886-2-26461778

No. 15, Lane 530, Pa-Lian RD., Sec. 1, Hsichih City, Taipei Hsien, Taiwan, R.O.C.

CERTIFICATION

We here by verify that:

The test data, data evaluation, test procedures and equipment configurations shown in this report were made mainly in accordance with the procedures given in ANSI C63.4 (1992) as a reference. All test were conducted by *Training Research Co., Ltd.*, 255 Nanyang Street, Shijr, Taipei Hsien 221, Taiwan, R.O.C. Also, we attest to the accuracy of each.

We further submit that the energy emitted by the sample EUT tested as described in the report is **in compliance with** the technical requirements set forth in the FCC Rules Part 15 Subpart B (Declaration of Conformity) and C Section 15.247.

Applicant : Well Communication Corp.
Applicant address : 11F, No.778, Chung Cheng Rd., Chung Ho City, Taipei Hsien, Taiwan, R.O.C.
Product Name : 802.11g Wireless AP
Model Name : WLL-5410R
FCC ID : JCHWLL-5410R
Report No. : W0115687
Test Date : July 8, 2004

Prepared by:

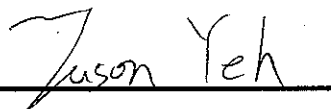

Jason Yeh

Approved by:



Jacob Lin

Conditions of issue :

- (1) **This test report shall not be reproduced except in full, without written approval of TRC. And the test result contained within this report only relate to the sample submitted for testing.**
- (2) **This report must not be used by the client to claim product endorsement by NVLAP or any agency of U.S. Government.**

★ NVLAP LAB CODE: 200174-0

Federal Communications Commission

Declaration of Conformity (DoC)

For the Following Equipment:

Product name : 802.11g Wireless AP

Model name : WLL-5410R

Trade name : Origo

Is herewith confirmed and found to comply with the requirements of CFR 47 part15 Subpart B - Unintentional Radiators regulation. The results of electromagnetic mission evaluation are shown in the report number : W0115687

This device complies with Part 15 of the FCC Rules. Operation is subject to the following two conditions:

- (1) This device may not cause harmful interference, and
- (2) This device must accept any interference received, including interference that may cause undesired operation

<i>Manufacturer</i>	<i>USA local representative</i>
Company name: Well Communication Corp.	Hiro Inc.
Computer address: 11F, No.778, Chung Cheng Rd., Chung Ho City, Taipei Hsien, Taiwan, R.O.C.	20103 Padrion Ave. Walnut, CA91789
ZIP / Postal code 235	
Contact person: BILL LEI	
Title: Department Manager	
Internet e-mail address: vincent@wellgroups.com	
Tel / Fax: 886-2-32340000 / 886-2-32340193	002-1-9095766607

Tables of Contents

I. GENERAL	6
1.1 Introduction	6
1.2 Description of EUT	6
1.3 Test method	7
1.4 Description of Support Equipment	6
1.5 Configuration of System Under Test	10
1.6 Verify the Frequency and Channel	12
1.7 Test Procedure	13
1.8 Location of the Test Site	13
1.9 General Test Condition	13
II. Section 15.101(a) : Equipment Authorization of Unintentional Radiators	14
III. Section 15.203 : Antenna Requirement	15
IV. Section 15.207 : Power Line Conducted Emissions for AC Powered Units	16
4.1 Test Condition & Setup	16
4.2 List of Test Instruments	16
4.3 Test Result of Conducted Emissions	17
802.11b	17
802.11g	20
V. Section 15.247(a) : Technical Description of the EUT	24
VI. Section 15.247(a)(2) : Bandwidth for Direct Sequence System	25
6.1 Test Condition & Setup	25
6.2 Test Instruments Configuration	25
6.3 List of Test Instruments	25
6.4 Test Result of Bandwidth	26
Channel 01	27
Channel 06	28
Channel 11	29

VII. Section 15.247(b) : Power Output	30
7.1 Test Condition & Setup	30
7.2 List of Test Instruments	30
7.3 Test Result	31
VIII. Section 15.247(c) : Spurious Emissions (Radiated)	32
8.1 Test Condition & Setup	32
8.2 List of Test Instruments	33
8.3 Test Result of Spurious Radiated Emissions	34
Below 1GHz	34
Above 1GHz	36
8.4 Test Result of Bandedge	42
802.11b	43
802.11g	45
IX. Section 15.247(d) : Power Spectral Density	47
9.1 Test Condition & Setup	47
9.2 Test Instruments Configuration	47
9.3 List of Test Instruments	47
9.4 Test Result of Power Spectral Density	48
Channel 01	49
Channel 06	50
Channel 11	51

I . GENERAL

1.1 Introduction

The following measurement report is submitted on behalf of applicant in support that the certification in accordance with Part 2 Subpart J and Part 15 Subpart A, B and C of the Commission's Rules and Regulations.

1.2 Description of EUT

Product Name	:	802.11g Wireless AP
Model Name	:	WLL-5410R
Granted FCC ID	:	JCHWLL-5410R
Frequency Range	:	2.412 GHz ~ 2.462GHz
Support Channel	:	11 Channel
Modulation Skill	:	DBPSK, DQPSK, CCK, OFDM
Power Type	:	Power Adaptor Mfg.: OEM M/N: AD-052A I/P: 120Vac, 60Hz; 140mA O/P: 5Vdc, 2.0A
Power Cable	:	185cm long, non-shielded, no ferrite core

1.3 Test method

- 1 The POWER jack of EUT is connected with the AC power source via an AC to DC adaptor
- 2 The LAN-3 jack of EUT is connected with a LAN card of nearby PC, the LAN-4 jack is connected with another LAN card, which install in far-end PC. Than other LAN ports and WAN port connected with 100ohm terminal.
- 3 Connected the USB port of EUT with a camera through the USB shield cable.
- 4 Connected the parallel port of EUT with a printer.
- 5 Using the LAN port of computer and software to control the EUT. The software provided by the manufacturer to control the EUT in the continuous transmission mode, the test is performed under those specific conditions.

- 6 Set different data rate (11Mbps/54Mbps) and channel (CH1/CH6/CH11) being tested and repeat the procedures above.
 - (a) Radiated for intentional test:
 - making EUT to the mode of continuous transmission
 - (b) Conducted and Radiated for unintentional test:
 - making EUT to the linking (Rx/Tx) mode with support equipments

1.4 Description of Support Equipment

In order to construct the minimum testing, following equipment were used as the support units.

- | | |
|--------------------|---|
| Printer | : HP |
| Model No. | : C6464A |
| Serial No. | : TH16LEB5PK |
| FCC ID | : N/A, DoC Approved |
| 檢磁 | : 3892H381 |
| Power type | : Switching adaptor |
| Power cord | : Non-shielded, 173cm long, No ferrite core (between adaptor and AC source) |
| | : Non-shielded, 180cm long, with ferrite core (between printer and adaptor) |
| Data cable | : Shielded, 1.70m long, No ferrite core |
| Fax/Modem | : Aceex |
| Model No. | : DM-1414 |
| Serial No. | : 9010582 |
| FCC ID | : IFAXDM1414 |
| Power type | : 110 VAC / 50 ~ 60 Hz, Switching |
| Power Cord | : Non-shielded, 1.90m long, Plastic hoods, and no ferrite bead |
| Data Cable | : RS-232→Shielded, 1.30m long, Metal hoods , No bead |
| | : RJ-11Cx2→Non-shielded, 7' long, Plastic hoods, No bead |
| USB Gamepad | : Rockfire |
| Model No. | : QF-337uv |
| Serial No. | : 10600545, KR91379759 |
| FCC ID | : None (CE approval) |
| 檢磁 | : 3862A574 |
| Power type | : By computer |
| Data Cable | : Shielded, 1.81m long, Plastic, with ferrite core |

Camera : **Logitech**
Model No. : V-UJ16
Serial No. : LZA30600780
Product No. : 861095-0010
檢磁 : 4912A026
FCC ID : N/A, DoC Approved
Power type : 5V, 300mA

PC : **HP Pavilion**
Model No. : P8574A
Serial No. : TW21920435
FCC ID : DoC Approved
檢磁 : 3902H097
Power type : 100 ~ 127VAC / 4A, 200 ~ 240VAC/2A, 50 ~ 60Hz, 5A, Switching
Power cord : Non-shielded, 2.33 m length, Plastic hood, No ferrite core

Monitor : **HP 15' Color Monitor**
Model No. : D2827A
Serial No. : KR91161719
FCC ID : C5F7NFCMC1518X
檢磁 : 3872B039
Power type : 110 ~ 240 VAC / 50 ~ 60 Hz, Switching
Power cord : Shielded, 1.83m long, No ferrite core
Data cable : Shielded, 1.46m long, with two ferrite cores

Keyboard : **HP**
Model No. : 5187-0343
Serial No. : BE21700404
FCC ID : DoC Approved
檢磁 : 3892C981
Data cable : Shielded, 1.73m length, Plastic hood, No ferrite core

Mouse : **HP**
Model No. : M-S34
Serial No. : LZB90714106
FCC ID : DZL211029
檢磁 : 4862A011
Power cord : Non-shielded, 1.88m long, No ferrite core

Notebook : **ASUSTek Computer**
Model No. : AB00F
Serial No. : 24NP016361
FCC ID : DoC Approved
BSMI : 41016012
Power type : 100 ~ 240VAC, 1A 50/60 Hz, Switching

Adaptor of PC : **LITE-ON Electronics, Inc.**
Model No. : PA-1530-01
Serial No. : 00151184
FCC ID : Doc Approved
檢磁 : 3882B259
Power cable : Non-shielded, 1.72m length, Plastic hood, No ferrite core
(Between power adaptor and AC power source)
Power cable : Shielded, 1.48m length, Plastic hood, with ferrite core
(Between power adaptor and notebook)

WLAN Card : **Gemtek Technology Co., Ltd.**
Model No. : C911003
FCC ID : MXF-C911003

1.5 Configuration of System Under Test

(Conducted and Radiated of unintentional powered by adaptor)

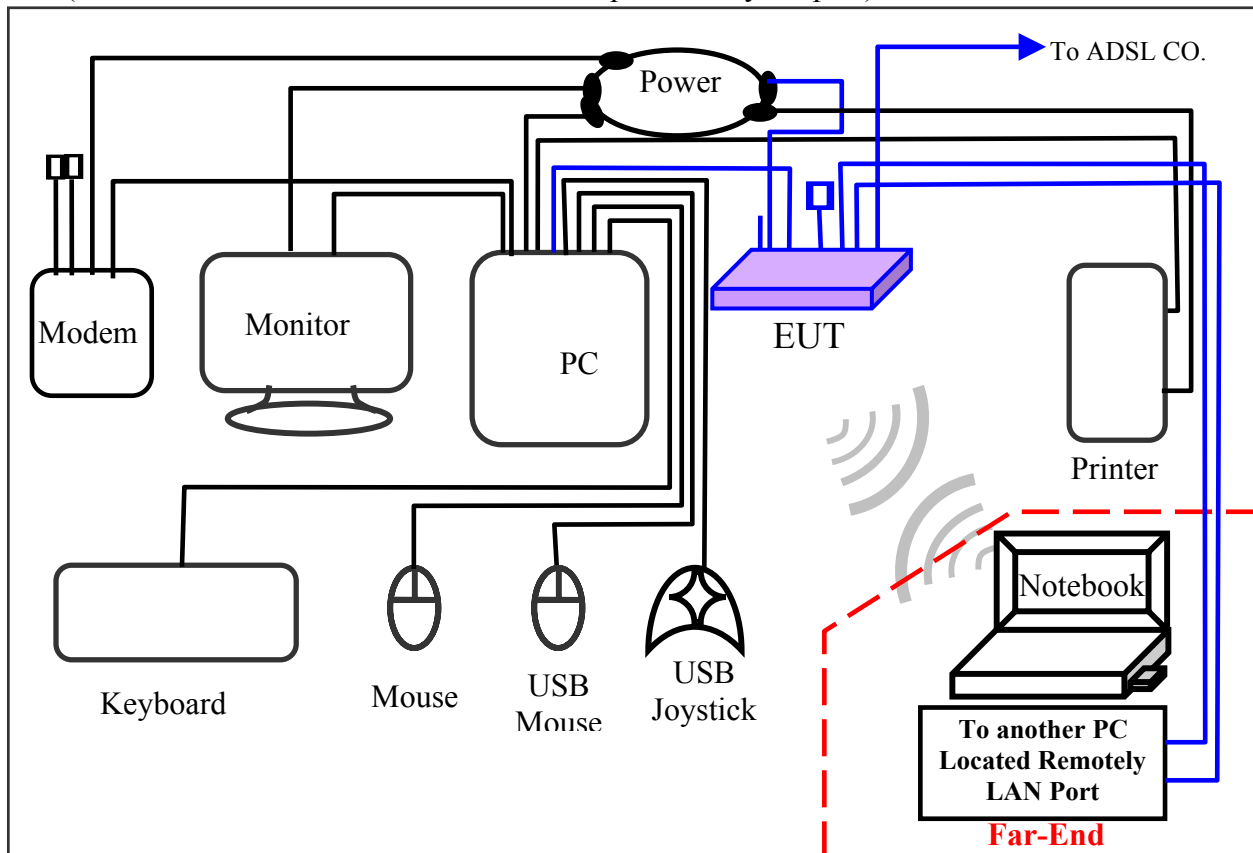

(Conduction and Radiation for unintentional test)

The setting up procedure was in Appendix A.

Connections of PC:

- *Serial Port --- via a 110cm shielded RS-232 cable to the serial port of Modem.
 - *Monitor Port --- a monitor with 1.5m length data cable.
 - *Keyboard Port --- a keyboard with 1.60m length data cable.
 - *Mouse Port --- a mouse with 1.8m length data cable.
 - *USB port A --- a USB mouse with 1.8m length data cable.
 - *USB port B --- a USB joystick with 1.8m length data cable.
 - *Printer port --- a printer with 1.80m length data cable.
- (Each port on PC is connected with suitable device)

Connections of EUT:

- *WAN Port --- via a 10m long, non-shielded, no ferrite bead, RJ-45 cable to the ADSL C.O.
- *UTP 1,2 port --- via a 10m long, non-shielded, no ferrite bead, RJ-45 cable to the RJ-45 jack of the LAN card that installed in the PC located remotely.
- *UTP 3 port --- connect with a 2m length RJ-45 cable that terminated with 200ohm.
- *UTP 4 port --- via a 1m long, non-shielded, no ferrite bead, RJ-45 cable to the LAN card of PC.
- *Power jack --- with a power adapter that the power cable is 1.50m long, non-shielded.

(Radiated of intentional power by adaptor)

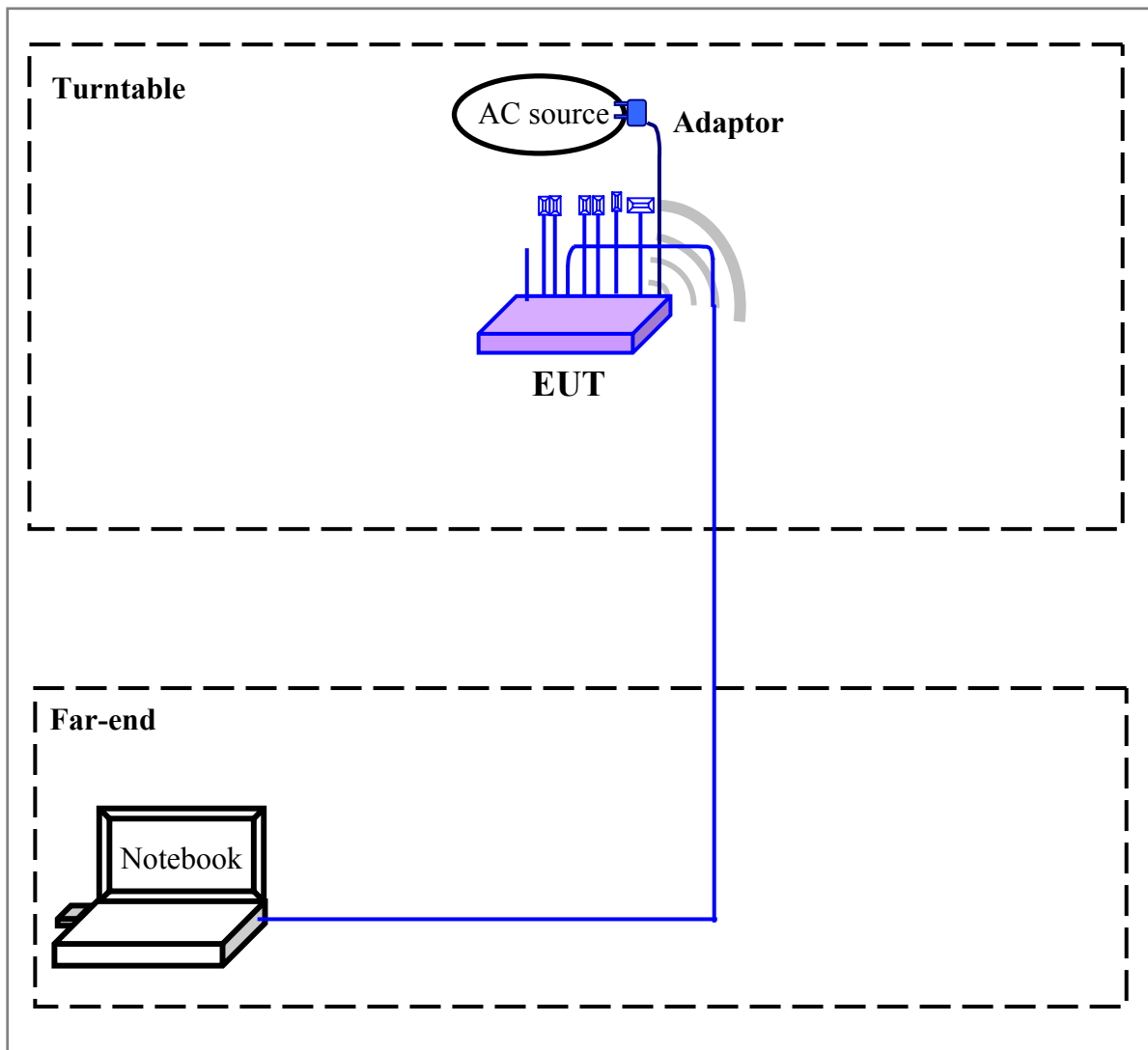

The tests below are carried with the EUT transmitter set at high power in TDD mode. The EUT is forced to select of output power level and channel number by notebook computer.

The setting up procedure was recorded in 1.3 test method.

1.6 Verify the Frequency and Channel

Channel	Frequency (GHz)
1	2.412
2	2.417
3	2.422
4	2.427
5	2.432
6	2.437
7	2.442
8	2.447
9	2.452
10	2.457
11	2.462

Note:

1. This is for confirming that all frequencies are in 2.412GHz to 2.462GHz.
2. Section 15.31(m): Measurements on intentional radiators or receivers shall be performed at three frequencies for operating frequency range over 10 MHz.
(The locations of these frequencies one near the top, one near the middle and one near the bottom.)
3. After test, the EUT operating frequencies are in 2.412GHz to 2.462GHz. So all the items as followed in testing report are need to test these three frequencies:
Top: Channel – 1; Middle: Channel – 6; Bottom: Channel – 11.

1.7 Test Procedure

All measurements contained in this report were performed mainly according to the techniques described in ANSI C63.4 (1992) and the pre-setup was written on 1.3 test method, the detail setup was written on each test item.

1.8 Location of the Test Site

The radiated emissions measurements required by the rules were performed on the **three-meter, Anechoic Chamber (Registration Number: 93906)** maintained by *Training Research Co., Ltd.* 1F, No. 255 Nanyang Street, Shijr, Taipei Hsien 221, Taiwan, R.O.C. Complete description and measurement data have been placed on file with the commission. The conducted power line emissions tests and other test items were performed in a anechoic chamber also located at Training Research Co., Ltd.

No. 255 Nanyang Street, Shijr, Taipei Hsien 221, Taiwan, R.O.C. *Training Research Co., Ltd.* is listed by the FCC as a facility available to do measurement work for others on a contract basis.

1.9 General Test Condition

The conditions under which the EUT operates were varied to determine their effect on the equipment's emission characteristics. The final configuration of the test system and the mode of operation used during these tests were chosen as that which produced the highest emission levels. However, only those conditions, which the EUT was considered likely to encounter in normal use were investigated.

In test, they were set in high power and continuously transmitting mode that controlled by computer. The ch01, ch06 and ch11 of EUT were all tested. The setting up procedure is recorded on 1.3 test method.

II. Section 15.101(a): Equipment authorization of unintentional radiators

The EUT equipped with a LAN interface and should be operated with the computer. It was categorized to *Class B personal computers and peripherals* as cannot be operated stand-alone. The authorization requires **Declaration of Conformity (DoC)** and the items required such as Sect.15.107 (Conducted limits) and Sect.15.109 (Radiated emission limits) is same as Sect.15.207 and 15.247(C).

III. Section 15.203: Antenna requirement

The EUT can be equipped with detachable antenna. The detachable external antenna is affixed to the EUT using a unique connector, which allows for replacement of a broken antenna, but does not use a standard antenna jack or electrical connector.

The custom antenna specification of list as below:

Manufacturer	:	WELL COMMUNICATION CORP
Part No	:	6602113031-100
Connector	:	I-PEX Plug Reverse
Antenna Type	:	Home Antenna
Antenna Gain	:	5dBi (Max.)

IV. Section 15.207: Power Line Conducted Emissions for AC Powered Units

4.1 Test Condition & Setup

The power line conducted emission measurements were performed in an anechoic chamber. The EUT was assembled on a wooden table, which is 80 centimeters high, was placed 40 centimeters from the backwall and at least 1 meter from the sidewall.

Power was fed to the EUT from the public utility power grid through a line filter and Line Impedance Stabilization Networks (LISNs). The LISN housing, measuring instrumentation case, ground plane, etc., were electrically bonded together at the same RF potential. The Spectrum analyzer (or EMI receiver) was connected to the AC line through an isolation transformer. The 50-ohm output of the LISN was connected to the spectrum analyzer directly. Conducted emission levels were in the CISPER quasi-peak and average detection mode. The analyzer's 6 dB bandwidth was set to 9 KHz. No post-detector video filter was used.

The spectrum was scanned from 150 KHz to 30 MHz. The physical arrangement of the test system and associated cabling was varied (within the scope of arrangements likely to be encountered in actual use) to determine the effect on the unit's emanations in amplitude and frequency. All spurious emission frequencies were observed. The highest emission amplitudes relative to the appropriate limit were measured and have been recorded in paragraph 2.4.

There is a test condition apply in this test item, the test procedure description as <1.3>. Three channels were tested, one in the top (CH01), one in the middle (CH06) and the other in bottom (CH11).

4.2 List of Test Instruments

Instrument Name	Model No.	Brand	Serial No.	<u>Calibration Date</u>	
				Last time	Next time
EMI Receiver	8546A	H P	3520A00242	06/28/04	06/28/05
RF Filter Section	85460A	H P	3448A00217	06/28/04	06/28/05
LISN (EUT)	LISN-01	TRC	9912-03,04	06/04/04	06/04/05
LISN (Support E.)	LISN-01	TRC	9912-05	07/15/04	07/15/05
Auto Switch Box (< 30MHz)	ASB-01	TRC	9904-01	11/20/03	11/20/04

The level of confidence of 95%, the uncertainty of measurement of conducted emission is ± 2.02 dB.

4.3 Test Result of Power Line Conducted Emissions

EUT station transmit only

The following table shows a summary of the highest emissions of power line conducted emissions on the LIVE and NETURAL conductors of the EUT power cord. Show as follows.

Test Conditions: Temperature : 25.0 °C Humidity : 75 % RH

Table 1 Test mode: 802.11b, Channel 1

Conductor	Power Connected Emissions				FCC Class B		
	Frequency (KHz)	Peak (dBµV)	QP (dBµV)	Average (dBµV)	QP-limit (dBµV)	AVG-limit (dBµV)	Margin (dB)
Line 1	164.00	51.40	---	---	65.60	55.60	-4.20
	192.00	40.48	---	---	64.80	54.80	-4.32
	233.00	48.80	---	---	63.63	53.63	-4.82
	303.00	47.02	---	---	61.63	51.63	-4.61
	358.00	45.29	---	---	60.06	50.06	-4.77
	14230.00	36.09	---	---	60.00	50.00	-13.91
	16250.00	44.29	---	---	60.00	50.00	-5.71
	18250.00	43.84	---	---	60.00	50.00	-6.16
	21650.00	37.31	---	---	60.00	50.00	-12.69
	23130.00	35.79	---	---	60.00	50.00	-14.21
Line 2	169.00	51.17	---	---	65.46	55.46	-4.28
	182.00	50.40	---	---	65.09	55.09	-4.68
	238.00	47.92	---	---	63.49	53.49	-5.56
	307.00	45.54	---	---	61.51	51.51	-5.97
	358.00	43.87	---	---	60.06	50.06	-6.19
	13350.00	36.64	---	---	60.00	50.00	-13.36
	14700.00	38.96	---	---	60.00	50.00	-11.04
	16250.00	45.40	---	---	60.00	50.00	-4.60
	17700.00	43.66	---	---	60.00	50.00	-6.34
	19700.00	34.69	---	---	60.00	50.00	-15.31

NOTE:

- (1)Margin = Peak Amplitude – Limit, *The reading amplitudes are all under limit.*
- (2)A "+" sign in the margin column means the emission is OVER the Class B Limit and "-" sign of means UNDER the Class B limit

Table 2 Test mode: 802.11b, Channel 6

<i>Power Connected Emissions</i>					<i>FCC Class B</i>		
<i>Conductor</i>	<i>Frequency (KHz)</i>	<i>Peak (dBμV)</i>	<i>QP (dBμV)</i>	<i>Average (dBμV)</i>	<i>QP-limit (dBμV)</i>	<i>AVG-limit (dBμV)</i>	<i>Margin (dB)</i>
Line 1	155.00	51.61	---	---	65.86	55.86	-4.25
	192.00	50.62	---	---	64.80	54.80	-4.18
	233.00	48.80	---	---	63.63	53.63	-4.82
	256.00	47.94	---	---	62.97	52.97	-5.03
	298.00	47.04	---	---	61.77	51.77	-4.74
	14150.00	36.01	---	---	60.00	50.00	-13.99
	16250.00	44.06	---	---	60.00	50.00	-5.94
	18330.00	42.29	---	---	60.00	50.00	-7.71
	19700.00	37.78	---	---	60.00	50.00	-12.22
	23130.00	36.72	---	---	60.00	50.00	-13.28
Line 2	159.00	51.16	---	---	65.74	55.74	-4.58
	192.00	49.88	---	---	64.80	54.80	-4.92
	224.00	48.70	---	---	63.89	53.89	-5.18
	238.00	47.95	---	---	63.49	53.49	-5.53
	275.00	46.52	---	---	62.43	52.43	-5.91
	321.00	44.93	---	---	61.11	51.11	-6.18
	13430.00	38.55	---	---	60.00	50.00	-11.45
	15250.00	40.59	---	---	60.00	50.00	-9.41
	16250.00	44.10	---	---	60.00	50.00	-5.90
	17700.00	41.46	---	---	60.00	50.00	-8.54

Table 3 Test mode: 802.11b, Channel 11

Conductor	Power Connected Emissions				FCC Class B		
	Frequency (KHz)	Peak (dBµV)	QP (dBµV)	Average (dBµV)	QP-limit (dBµV)	AVG-limit (dBµV)	Margin (dB)
Line 1	164.00	51.21	---	---	65.60	55.60	-4.39
	192.00	50.18	---	---	64.80	54.80	-4.62
	229.00	48.74	---	---	63.74	53.74	-5.00
	256.00	47.98	---	---	62.97	52.97	-4.99
	298.00	46.59	---	---	61.77	51.77	-5.19
	1563.00	37.17	---	---	60.00	50.00	-12.83
	16180.00	42.03	---	---	60.00	50.00	-7.97
	17700.00	44.61	---	---	60.00	50.00	-5.39
	19700.00	38.82	---	---	60.00	50.00	-11.18
	21650.00	35.87	---	---	60.00	50.00	-14.12
Line 2	155.00	51.28	---	---	65.86	55.86	-4.58
	173.00	50.09	---	---	65.34	55.34	-5.25
	196.00	49.40	---	---	64.69	54.69	-5.29
	229.00	48.25	---	---	63.74	53.74	-5.49
	243.00	47.49	---	---	63.34	53.34	-5.85
	14230.00	36.08	---	---	60.00	50.00	-13.92
	15630.00	38.65	---	---	60.00	50.00	-11.35
	16250.00	43.83	---	---	60.00	50.00	-6.17
	18250.00	41.91	---	---	60.00	50.00	-8.09
	19700.00	35.12	---	---	60.00	50.00	-14.88

Table 4 Test mode: 802.11g, Channel 1

Conductor	Power Connected Emissions			FCC Class B			
	Frequency (KHz)	Peak (dBµV)	QP (dBµV)	Average (dBµV)	QP-limit (dBµV)	AVG-limit (dBµV)	Margin (dB)
Line 1	182.00	50.61	---	---	65.09	55.09	-4.47
	201.00	49.84	---	---	64.54	54.54	-4.70
	219.00	49.33	---	---	64.03	54.03	-4.70
	261.00	48.07	---	---	62.83	52.83	-4.76
	284.00	47.06	---	---	62.17	52.17	-5.11
	15450.00	39.08	---	---	60.00	50.00	-10.92
	16250.00	44.37	---	---	60.00	50.00	-5.63
	18250.00	42.35	---	---	60.00	50.00	-7.65
	19700.00	38.82	---	---	60.00	50.00	-11.18
	23130.00	35.74	---	---	60.00	50.00	-14.26
Line	169.00	50.76	---	---	65.46	55.46	-4.69
	201.00	49.44	---	---	64.54	54.54	-5.10
	256.00	47.09	---	---	62.97	52.97	-5.88
	284.00	46.26	---	---	62.17	52.17	-5.91
	317.00	44.93	---	---	61.23	51.23	-6.30
	13480.00	37.10	---	---	60.00	50.00	-12.90
	15630.00	40.46	---	---	60.00	50.00	-9.54
	16250.00	43.80	---	---	60.00	50.00	-6.20
	17700.00	43.77	---	---	60.00	50.00	-6.23
	23130.00	34.03	---	---	60.00	50.00	-15.97

Table 5 Test mode: 802.11g, Channel 6

Conductor	Power Connected Emissions			FCC Class B			
	Frequency (KHz)	Peak (dBμV)	QP (dBμV)	Average (dBμV)	QP-limit (dBμV)	AVG-limit (dBμV)	Margin (dB)
Line 1	155.00	51.35	---	---	65.86	55.86	-4.51
	173.00	50.93	---	---	65.34	55.34	-4.44
	215.00	49.76	---	---	64.14	54.14	-4.38
	275.00	47.32	---	---	62.43	52.43	-5.11
	321.00	46.02	---	---	61.11	51.11	-5.09
	15250.00	36.45	---	---	60.00	50.00	-13.55
	16250.00	43.01	---	---	60.00	50.00	-6.99
	17700.00	43.31	---	---	60.00	50.00	-6.69
	18930.00	39.46	---	---	60.00	50.00	-10.54
	21900.00	34.67	---	---	60.00	50.00	-15.33
Line 2	173.00	50.42	---	---	65.34	55.34	-4.92
	187.00	49.96	---	---	64.94	54.94	-4.98
	219.00	48.27	---	---	64.03	54.03	-5.76
	256.00	46.81	---	---	62.97	52.97	-6.16
	317.00	44.68	---	---	61.23	51.23	-6.55
	14280.00	37.25	---	---	60.00	50.00	-12.75
	15450.00	37.44	---	---	60.00	50.00	-12.56
	16250.00	43.30	---	---	60.00	50.00	-6.70
	17700.00	42.51	---	---	60.00	50.00	-7.49
	18930.00	35.67	---	---	60.00	50.00	-14.33

Table 6 Test mode: 802.11g, Channel 11

Power Connected Emissions					FCC Class B		
Conductor	Frequency (KHz)	Peak (dBµV)	QP (dBµV)	Average (dBµV)	QP-limit (dBµV)	AVG-limit (dBµV)	Margin (dB)
Line 1	164.00	51.28	---	---	65.60	55.60	-4.32
	178.00	50.71	---	---	65.20	55.20	-4.49
	233.00	48.57	---	---	63.63	53.63	-5.05
	275.00	47.43	---	---	62.43	52.43	-5.00
	15630.00	37.42	---	---	60.00	50.00	-12.58
	16250.00	43.87	---	---	60.00	50.00	-6.13
	17700.00	43.31	---	---	60.00	50.00	-6.69
	19700.00	38.26	---	---	60.00	50.00	-11.74
	21650.00	36.44	---	---	60.00	50.00	-13.56
	23130.00	35.18	---	---	60.00	50.00	-14.82
Line 2	164.00	50.90	---	---	65.60	55.60	-4.70
	182.00	50.07	---	---	65.09	55.09	-5.01
	206.00	49.07	---	---	64.40	54.40	-5.33
	243.00	47.45	---	---	63.34	53.34	-5.89
	284.00	46.28	---	---	62.17	52.17	-5.89
	7940.00	32.74	---	---	60.00	50.00	-17.26
	13430.00	37.14	---	---	60.00	50.00	-12.86
	16250.00	43.72	---	---	60.00	50.00	-6.28
	18250.00	41.91	---	---	60.00	50.00	-8.09
	19700.00	34.79	---	---	60.00	50.00	-15.21

Table 7 Test mode: Standby

Conductor	Power Connected Emissions			FCC Class B			
	Frequency (KHz)	Peak (dBμV)	QP (dBμV)	Average (dBμV)	QP-limit (dBμV)	AVG-limit (dBμV)	Margin (dB)
Line 1	169.00	50.01	---	---	65.46	55.46	-5.44
	192.00	49.39	---	---	64.80	54.80	-5.41
	224.00	48.63	---	---	63.89	53.89	-5.25
	252.00	47.36	---	---	63.09	53.09	-5.72
	289.00	45.93	---	---	62.03	52.03	-6.10
	13430.00	35.99	---	---	60.00	50.00	-14.01
	14230.00	36.14	---	---	60.00	50.00	-13.86
	16250.00	42.29	---	---	60.00	50.00	-7.71
	17700.00	41.78	---	---	60.00	50.00	-8.22
	23130.00	35.55	---	---	60.00	50.00	-14.45
Line 2	164.00	49.84	---	---	65.60	55.60	-5.76
	187.00	48.47	---	---	64.94	54.94	-6.47
	210.00	48.03	---	---	64.29	54.29	-6.26
	233.00	47.25	---	---	63.63	53.63	-6.37
	13350.00	37.22	---	---	60.00	50.00	-12.78
	14150.00	38.63	---	---	60.00	50.00	-11.37
	16180.00	43.37	---	---	60.00	50.00	-6.63
	17700.00	42.58	---	---	60.00	50.00	-7.42
	20230.00	33.58	---	---	60.00	50.00	-16.42
	23130.00	31.27	---	---	60.00	50.00	-18.73

V. Section 15.247 (a): Technical description of the EUT

Based on the Section 2.1, *Direct Sequence System* is a spread spectrum system in which the carrier has been modulated by a high speed spreading code and an information data stream. The high speed code sequence dominates the “modulating function” and is the direct cause of the wide spreading of the transmitted signal. In the operational description demonstrates the operation principles of the Baseband processor employed by the EUT, shows that which is a complete DSSS baseband processor and meets the definition of the Direct sequence spread spectrum system.

VI. Section 15.247(a)(2): Bandwidth for Direct Sequence System.

6.1 Test Condition & Setup

The transmitter bandwidth measurements were performed by the contact manner. The EUT was set to transmit continuously, also various channels were investigated to find the maximum occupied bandwidth.. The output of the EUT was connected to the spectrum analyzer. The bandwidth of the fundamental frequency is observed by the spectrum analyzer with 100kHz RBW and 100kHz VBW.

6.2 Test Instruments Configuration

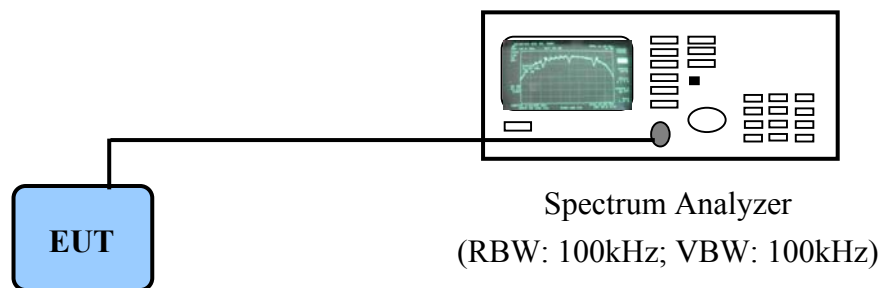

P.S.: Notebook computer to control the EUT at maximal power output and channel Number and set antenna kit

6.3 List of Test Instruments

Instrument Name	Model No.	Brand	Serial No.	Last time	Next time
Spectrum Analyzer	MS2665C	ANRITSU	6200175476	09/11/03	09/11/04

6.4 Test Result of Bandwidth

Bandwidth of Channel 1

Bandwidth (802.11b) : 8.96 MHz
Bandwidth (802.11g) : 16.64 MHz
The min. 6dB BW at least : 500 KHz

Bandwidth of Channel 6

Bandwidth (802.11b) : 10.76 MHz
Bandwidth (802.11g) : 16.76 MHz
The min. 6dB BW at least : 500 KHz

Bandwidth of Channel 11

Bandwidth (802.11b) : 8.44 MHz
Bandwidth (802.11g) : 16.72 MHz
The min. 6dB BW at least : 500 KHz

Note:

1. The data in the above table are summarizing the following attachment spectrum analyzer hard copy. According to the guidance, we'd made the measurement with the spectrum analyzer's resolution bandwidth (RBW)= $100kHz$ and set the $span \gg RBW$. The results show the measured 6dB bandwidth comply with the minimum 500kHz requirement.
2. The attachments show these on the following pages.

Bandwidth of Channel 1:

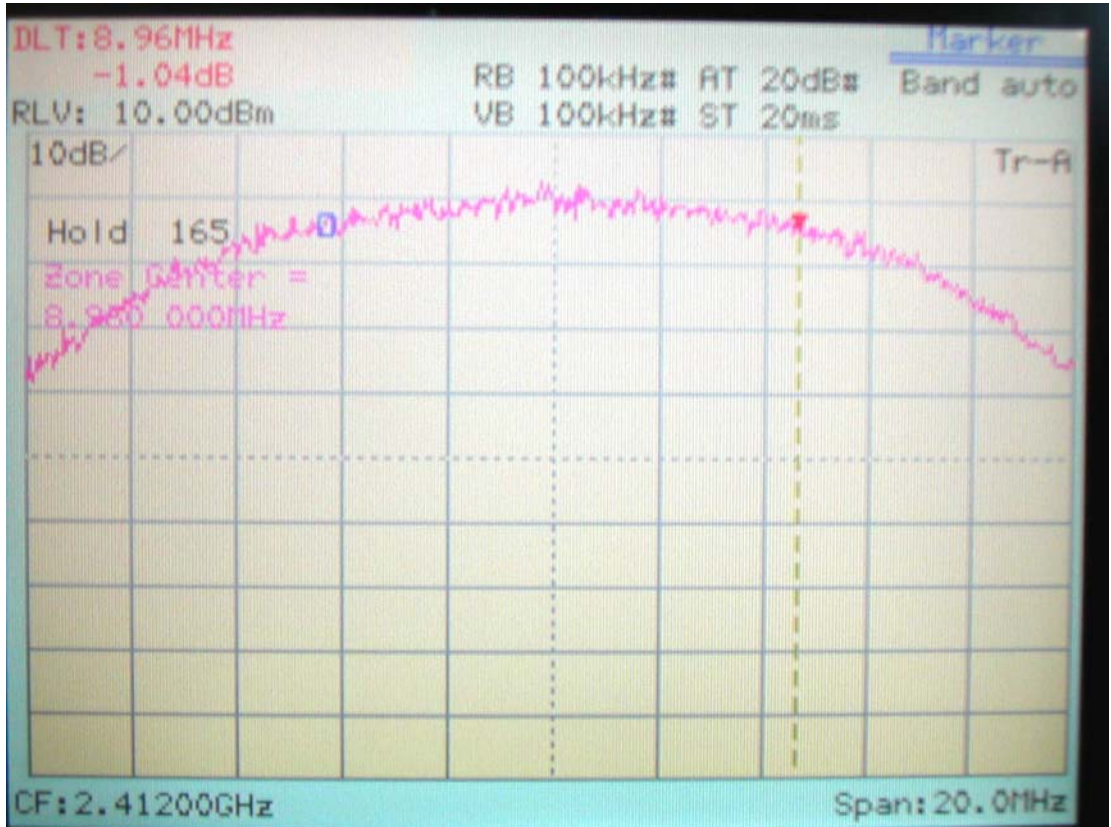

802.11b

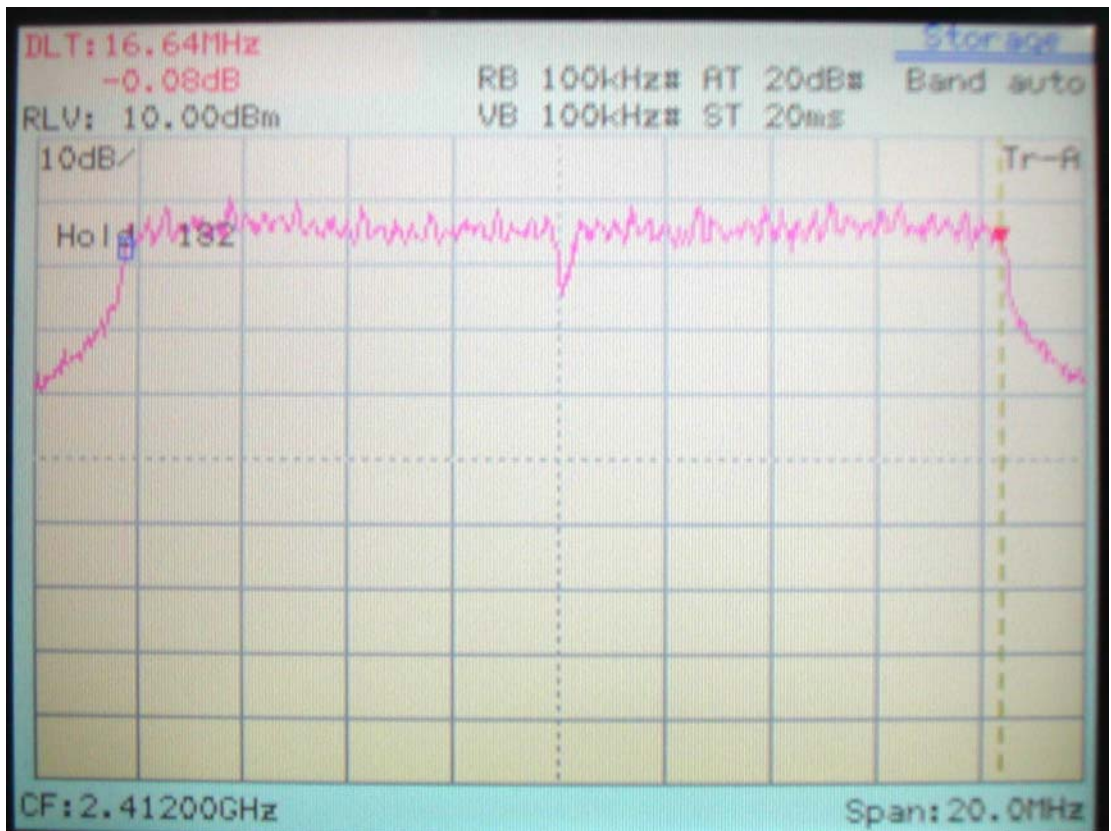

802.11g

Bandwidth of Channel 6:

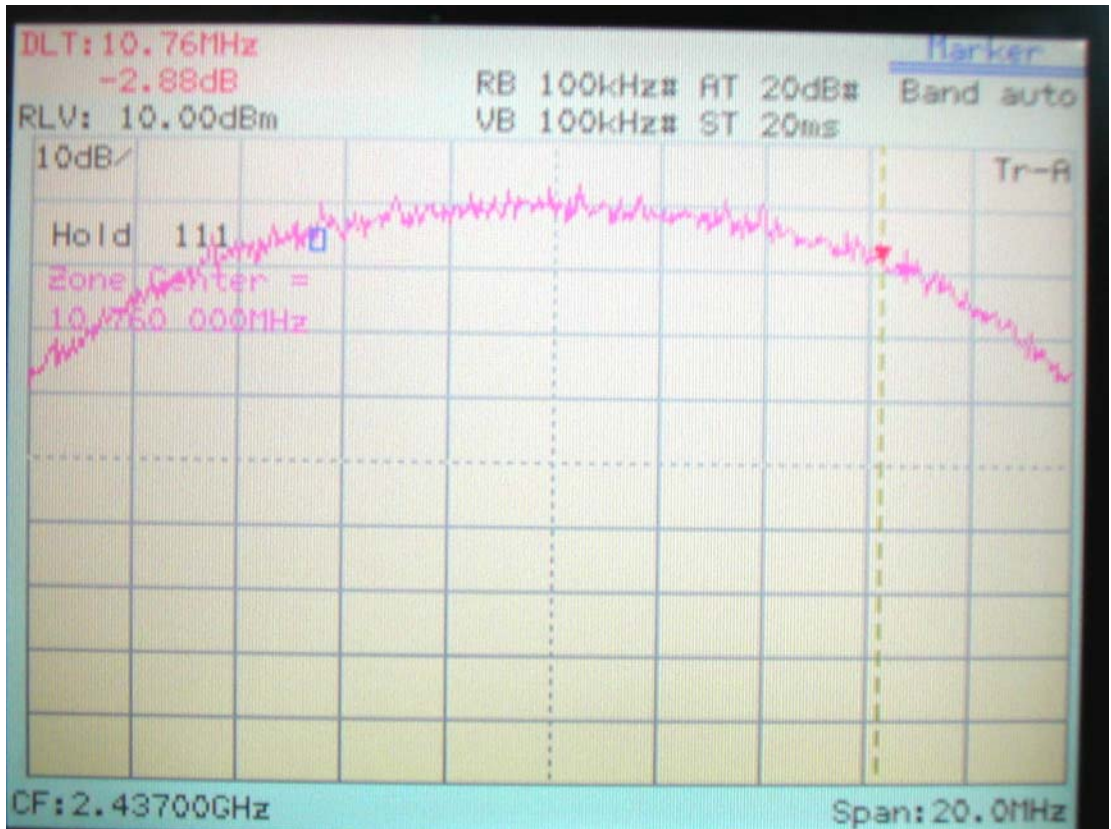

802.11b

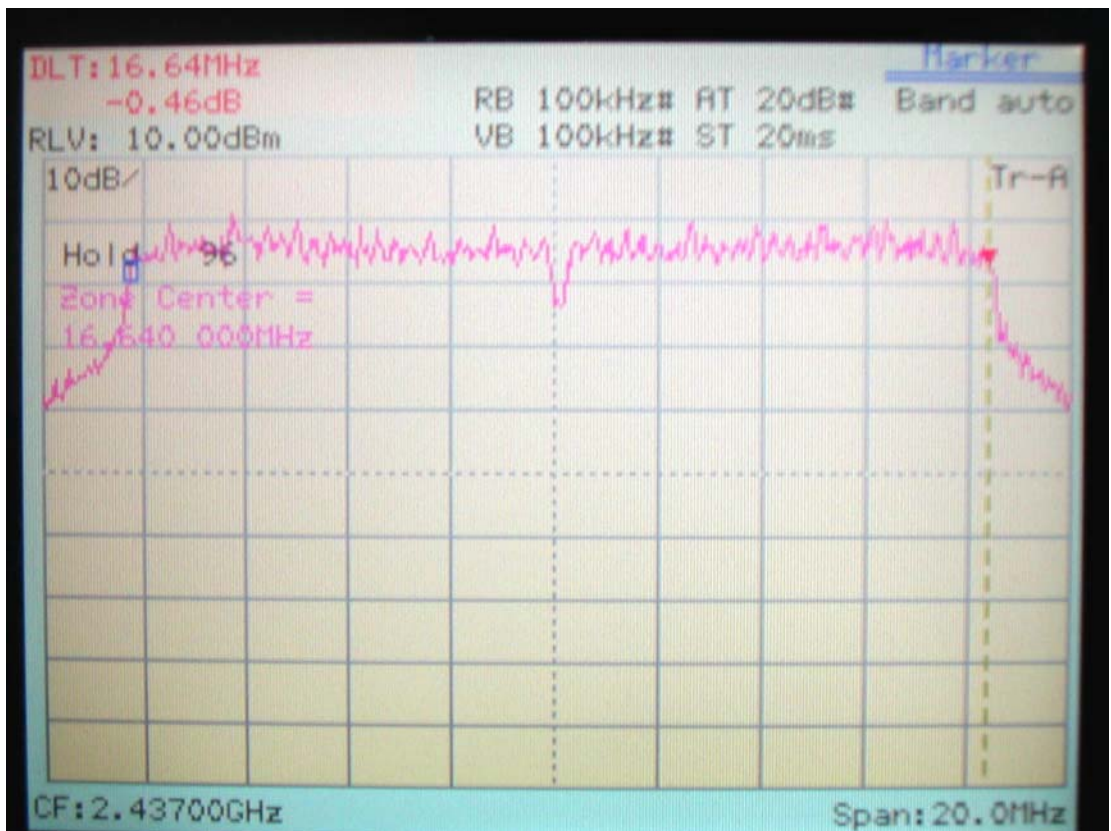

802.11g

Bandwidth of Channel 11:

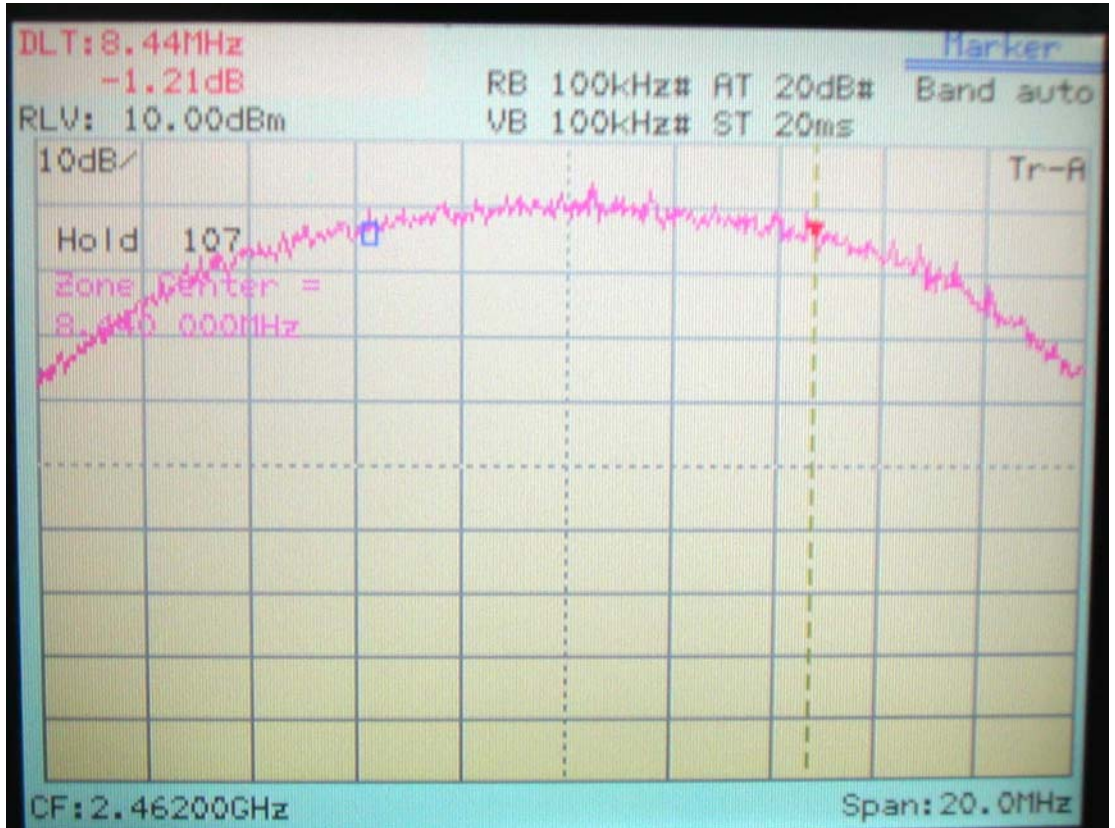

802.11b

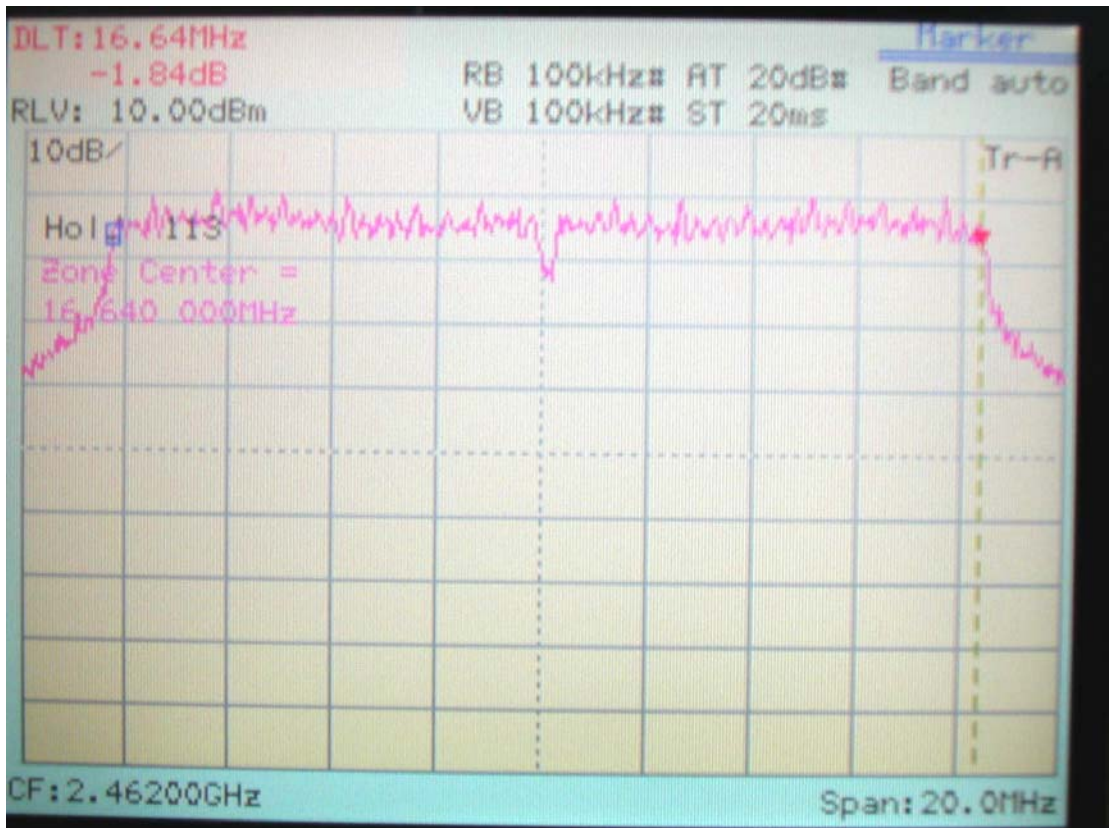

802.11g

VII. Section 15.247(b): Power Output

7.1 Test Condition & Setup

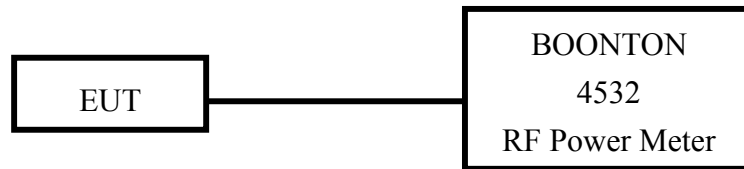

1. The output of the transmitter is connected to the BOONTON RF Power Meter.
2. The calibration is performed before every test. The values of the output power of the EUT will shown in the dBm directly are the transmitter output peak power. Recording as follows.

7.2 List of Test Instruments

Instrument Name	Model No.	Brand	Serial No.
RF Power Meter	4532	BOONTON	117501

7.3 Test Result

Formula:
 Signal generator + |Cable loss| = Output peak power

802.11b

Channel	Signal Generator	Cable Loss	Output peak power	
	dBm		dBm	mW
CH 1	12.99	0.50	13.49	22.336
CH 6	13.30	0.50	13.80	23.988
CH 11	13.66	0.50	14.16	26.062

The max power: 14.16dBm+ 5dBi = 19.16dBi

802.11g

Channel	Signal Generator	Cable Loss	Output peak power	
	dBm		dBm	MW
CH 1	15.56	0.50	16.16	41.305
CH 6	15.93	0.50	16.43	43.954
CH 11	16.12	0.50	16.62	45.920

The max power: 16.62dBm+ 5dBi = 21.62dBi

Max power = Conducted power + Ant gain

VIII. Section 15.247 (C): Spurious Emissions (Radiated)

8.1 Test Condition & Setup

We'd performed the test by the radiated emission skill: The EUT was placed in an anechoic chamber, and set the EUT transmitting continuously and scanned at 3-meter distance to determine its emission characteristics. The physical arrangement of the EUT was varied (within the scope of arrangements likely to be encountered in actual use) to determine the effect on the unit's emanations in amplitude, directivity, and frequency. The exact system configuration, which produced the highest emissions was noted so it could be reproduced later during the final tests. For the measurement above 1GHz, according to the guidance we'd set the spectrum analyzer's 6dB bandwidth RBW to 1MHz.

This was done to ensure that the final measurements would demonstrate the worst-case interference potential of the EUT.

Final radiation measurements were made on a three-meter, anechoic chamber. The EUT system was placed on a nonconductive turntable, which is 0.8 meters height, top surface 1.0 x 1.5 meter.

The spectrum was examined from 30 MHz to 1000 MHz using an Hewlett Packard 85460A EMI Receiver, M.E. whole range Bi-log antenna (Model No.: VULB9160) is used to measure frequency from 30 MHz to 1GHz. The final test is used the HP 85460A spectrum and 8564E spectrum was examined from 1GHz to 25GHz using an Hewlett Packard Spectrum Analyzer, EMCO/CMT Horn Antenna (Model 3115 / RA42-K-F-4B-C) for 1G - 25GHz.

At each frequency, the EUT was rotated 360 degrees, and the antenna was raised and lowered from one to four meters to find the maximum emission levels. Measurements were taken using both horizontal and vertical antenna polarization.

Appropriate preamplifiers were used for improving sensitivity and precautions were taken to avoid overloading or desensitizing the spectrum analyzer. There are two spectrum analyzers use on this testing, HP 85460A for frequency 30MHz to 1000MHz, and 8564E for frequency 1GHz to 25GHz. No post-detector video filters were used in the test. The spectrum analyzer's 6dB bandwidth was set to 120KHz (spectrum was examined from 30 MHz to 1000 MHz), the spectrum analyzer's 6 dB bandwidth was set to 1 MHz (spectrum was examined from 1GHz to 25GHz) and the analyzer was operated in the maximum hold mode. There is a test condition applies in this test item, the test procedure description as the following:

Three channels were tested, one in the top (CH01), one in the middle (CH06) and the other in bottom (CH11). The setting up procedure is recorded on <1.3>

With the transmitter operating from a AC source and using the internal of EUT, radiates spurious emissions falling within the restricted bands of 15.209 were measured at operating frequencies corresponding to upper, middle and bottom channels in the 2400 ~ 2483.5 MHz band.

The actual field intensity in decibels referenced to 1 microvolt per meter (dBμV/m) is determined by algebraically adding the measured reading in dBμV, the antenna factor (dB), and cable loss (dB) at the appropriate frequency. Since the EUT was set to transmit continuously, no *duty cycle* is present.

For frequency between 30MHz to 1000MHz

F_{Ia} (dBuV/m) = F_{Ir} (dBμV) + Correction Factors

F_{Ia} : Actual Field Intensity

F_{Ir} : Reading of the Field Intensity

Correction Factors = Antenna Factor + Cable Loss – Amplifier Gain

For frequency between 1GHz to 25GHz

F_{Ia} (dBμV/m) = F_{Ir} (dBμV) + Correction Factor

F_{Ia} : Actual Field Intensity

F_{Ir} : Reading of the Field Intensity

Correction Factors = Antenna Factor + Cable Loss – Amplifier Gain

8.2 List of Test Instruments

Instrument Name	Model No.	Brand	Serial No.	Last time	Next time
EMI Receiver	8546A	H P	3520A00242	06/28/04	06/28/05
RF Filter Section	85460A	H P	3448A00217	06/28/04	06/28/05
Bi-log Antenna	VULB9160	M. E.	3064	07/08/04	07/08/05
Switch/Control Unit (>30MHz)	3488A	HP	N/A	11/20/03	11/20/04
Auto Switch Box (>30MHz)	ASB-01	TRC	9904-01	11/20/03	11/20/04
Spectrum Analyzer	8564E	HP	US36433002	08/01/03	08/01/04
Microwave Preamplifier	83051A	HP	3232A00347	08/01/03	08/01/04
Horn Antenna	3115	EMCO	9704 – 5178	08/01/03	08/01/04
Horn Antenna	RA42-K-F-4B-C	CMT	961505-003	02/01/04	02/01/05
Anechoic Chamber (cable calibrated together)				05/20/04	05/20/05

The level of confidence of 95% , the uncertainty of measurement of radiated emission is ± 3.44dB.

8.3 Test Result of Spurious Radiated Emissions

EUT's transmit only

The highest peak values of radiated emissions from the EUT at various antenna heights, antenna polarizations, EUT orientation, etc. are recorded on the following.

Test Conditions: Temperature : 26.2 ° C Humidity : 53.8 % RH

Table 8 Test mode: 802.11b for 30MHz to 1GHz [Antenna polarity Horizontal]

Radiated Emission				Correction Factors (dB)	Corrected Amplitude (dBμV/m)	FCC Class B (3 m)	
Frequency (MHz)	Amplitude (dBμV)	Ant. H. (m)	Table ()			Limit (dBμV/m)	Margin (dB)
125.0076	39.21	2.26	55	-4.70	34.51	43.52	-9.01
250.0150	40.92	1.70	0	-1.80	39.12	46.02	-6.90
375.0200	39.05	1.00	196	3.15	42.20	46.02	-3.82
500.0263	36.07	1.50	0	6.80	42.87	46.02	-3.15
875.0400	28.94	1.00	100	15.65	44.59	46.02	-1.43

Table 9 Test mode: 802.11b for 30MHz to 1GHz [Antenna polarity Vertical]

Radiated Emission				Correction Factors (dB)	Corrected Amplitude (dBμV/m)	FCC Class B (3 m)	
Frequency (MHz)	Amplitude (dBμV)	Ant. H. (m)	Table ()			Limit (dBμV/m)	Margin (dB)
87.2220	39.48	1.19	0	-9.35	30.13	40.00	-9.87
125.0075	41.58	2.63	0	-4.70	36.88	43.52	-6.64
250.0138	40.66	1.00	139	-1.80	38.86	46.02	-7.16
375.0188	37.02	1.00	129	3.15	40.17	46.02	-5.85
500.0250	30.82	0.99	118	6.80	37.62	46.02	-8.40

Note:

1. Margin = Amplitude – limit, if margin is minus means under limit.
2. Corrected Amplitude = Reading Amplitude + Correction Factors
3. Correction factor = Antenna factor + (Cable Loss – Amplitude gain)

Table 10 Test mode: 802.11g for 30MHz to 1GHz [Antenna polarity Horizontal]

Radiated Emission				Correction Factors	Corrected Amplitude	FCC Class B (3 m)	
Frequency (MHz)	Amplitude (dBμV)	Ant. H. (m)	Table (°)			Limit (dBμV/m)	Margin (dB)
125.0038	38.59	2.67	0	-4.70	33.89	43.52	-9.63
250.0125	39.82	0.99	243	-1.80	38.02	46.02	-8.00
375.0186	35.22	1.00	185	3.15	38.37	46.02	-7.65
500.0238	33.73	0.99	96	6.80	40.53	46.02	-5.49
875.0400	29.18	1.00	96	15.65	44.83	46.02	-1.19

Table 11 Test mode: 802.11g for 30MHz to 1GHz [Antenna polarity Vertical]

Radiated Emission				Correction Factors	Corrected Amplitude	FCC Class B (3 m)	
Frequency (MHz)	Amplitude (dBμV)	Ant. H. (m)	Table (°)			Limit (dBμV/m)	Margin (dB)
87.2220	35.63	1.00	212	-9.35	26.28	40.00	-13.72
125.0070	44.20	1.00	310	-4.70	39.50	43.52	-4.02
250.0138	42.16	1.00	74	-1.80	40.36	46.02	-5.66
375.0175	36.58	1.00	80	3.15	39.73	46.02	-6.29
500.0238	32.17	1.00	231	6.80	38.97	46.02	-7.05

Table 12 Test mode: Channel 1, 802.11b for 1GHz to 25GHz [Horizontal]

Radiated Emission				Corrected Amplitude		FCC Class B (3m)		
Frequency (MHz)	Ant. H. (m)	Table ()	Correction Factors (dB)	(dBµV/m)		Limit (dBµV/m)		Margin (dB)
				Peak	Average	Peak	Ave.	
4823.12	1.00	330	3.76	42.36	---	73.96	53.96	-11.60
7233.75	1.00	250	10.07	46.01	---	73.96	53.96	-7.95
9644.37	1.00	53	11.44	48.22	---	73.96	53.96	-5.74

Table 13 Test mode: Channel 1, 802.11b for 1GHz to 25GHz [Vertical]

Radiated Emission				Corrected Amplitude		FCC Class B (3m)		
Frequency (MHz)	Ant. H. (m)	Table ()	Correction Factors (dB)	(dBµV/m)		Limit (dBµV/m)		Margin (dB)
				Peak	Average	Peak	Ave.	
4823.12	1.00	128	3.76	42.36	---	73.96	53.96	-11.60
7233.75	1.00	116	10.07	45.51	---	73.96	53.96	-8.45
9644.37	1.00	118	11.44	47.22	---	73.96	53.96	-6.74

Note:

1. Margin = Corrected - Limit.
2. The EUT utilizes a *permanently attached antenna*. In addition the spurious RF radiated emissions levels do comply with the *20dBc limit* both at its bandedges and other spurious emissions.
- 3.As stated in Section 15.35(b), for any frequencies above 1000MHz, radiated limits shown are based upon the use of measurement instrumentation employing an average detector function. As the results of our test, the peak amplitudes are already below the FCC limit. Thus the average amplitudes of the rest are omitted.

Table 14 Test mode: Channel 6, 802.11b for 1GHz to 25GHz [Horizontal]

Radiated Emission				Corrected Amplitude		FCC Class B (3m)		
Frequency (MHz)	Ant. H. (m)	Table ()	Correction Factors (dB)	(dBµV/m)		Limit (dBµV/m)		Margin (dB)
				Peak	Average	Peak	Ave.	
1510.42	1.00	359	15.73	50.89	---	73.96	53.96	-3.07
1737.50	1.00	134	12.19	48.35	---	73.96	53.96	-5.61
2720.83	1.00	54	9.91	45.57	---	73.96	53.96	-8.39
4877.50	1.00	20	3.97	42.74	---	73.96	53.96	-11.22
7318.33	1.00	0	10.31	45.25	---	73.96	53.96	-8.71
9747.08	1.00	169	11.89	46.33	---	73.96	53.96	-7.63
12187.92	1.00	123	9.74	48.18	---	73.96	53.96	-5.78

Table 15 Test mode: Channel 6, 802.11b for 1GHz to 25GHz [Vertical]

Radiated Emission				Corrected Amplitude		FCC Class B (3m)		
Frequency (MHz)	Ant. H. (m)	Table ()	Correction Factors (dB)	(dBµV/m)		Limit (dBµV/m)		Margin (dB)
				Peak	Average	Peak	Ave.	
1637.50	1.00	23	13.75	50.08	---	73.96	53.96	-3.88
1809.37	1.00	91	11.06	49.73	---	73.96	53.96	-4.23
3248.96	1.00	63	11.63	48.46	---	73.96	53.96	-5.50
4877.50	1.00	107	3.97	43.24	---	73.96	53.96	-10.72
7318.33	1.00	58	10.31	45.25	---	73.96	53.96	-8.71
9747.08	1.00	268	11.89	47.49	---	73.96	53.96	-6.47
12187.92	1.00	165	9.74	48.51	---	73.96	53.96	-5.45

Table 16 Test mode: Channel 11, 802.11b for 1GHz to 25GHz [Horizontal]

Radiated Emission				Corrected Amplitude		FCC Class B (3m)		
Frequency (MHz)	Ant. H. (m)	Table ()	Correction Factors (dB)	(dBμV/m)		Limit (dBμV/m)		Margin (dB)
				Peak	Average	Peak	Ave.	
4925.83	1.00	182	4.13	43.40	---	73.96	53.96	-10.56
7384.79	1.00	324	10.42	45.53	---	73.96	53.96	-8.43
9849.79	1.00	53	11.93	46.54	---	73.96	53.96	-7.42

Table 17 Test mode: Channel 11, 802.11b for 1GHz to 25GHz [Vertical]

Radiated Emission				Corrected Amplitude		FCC Class B (3m)		
Frequency (MHz)	Ant. H. (m)	Table ()	Correction Factors (dB)	(dBμV/m)		Limit (dBμV/m)		Margin (dB)
				Peak	Average	Peak	Ave.	
4925.83	1.00	216	4.13	44.57	---	73.96	53.96	-9.39
7384.79	1.00	265	10.42	45.70	---	73.96	53.96	-8.26
9849.79	1.00	24	11.93	47.21	---	73.96	53.96	-6.75

Table 18 Test mode: Channel 1, 802.11g for 1GHz to 25GHz [Horizontal]

Radiated Emission				Corrected Amplitude		FCC Class B (3m)		
Frequency (MHz)	Ant. H. (m)	Table ()	Correction Factors (dB)	(dBµV/m)		Limit (dBµV/m)		Margin (dB)
				Peak	Average	Peak	Ave.	
3215.62	1.00	6	11.47	47.13	---	73.96	53.96	-6.83
4823.12	1.00	280	3.76	42.53	---	73.96	53.96	-11.43
7233.75	1.00	42	10.07	46.35	---	73.96	53.96	-7.61
9638.33	1.00	58	11.42	47.36	---	73.96	53.96	-6.60

Table 19 Test mode: Channel 1, 802.11g for 1GHz to 25GHz [Vertical]

Radiated Emission				Corrected Amplitude		FCC Class B (3m)		
Frequency (MHz)	Ant. H. (m)	Table ()	Correction Factors (dB)	(dBµV/m)		Limit (dBµV/m)		Margin (dB)
				Peak	Average	Peak	Ave.	
3216.67	1.00	94	11.47	49.64	---	73.96	53.96	-4.32
4823.12	1.00	125	3.76	43.36	---	73.96	53.96	-10.60
7239.79	1.00	253	10.11	47.05	---	73.96	53.96	-6.91
9650.42	1.00	61	11.47	47.91	---	73.96	53.96	-6.05

Table 20 Test mode: Channel 6, 802.11g for 1GHz to 25GHz [Horizontal]

Radiated Emission				Corrected Amplitude		FCC Class B (3m)		
Frequency (MHz)	Ant. H. (m)	Table ()	Correction Factors (dB)	(dBµV/m)		Limit (dBµV/m)		Margin (dB)
				Peak	Average	Peak	Ave.	
1797.92	1.00	276	11.24	49.24	---	73.96	53.96	-4.72
2004.17	1.00	150	8.10	44.44	---	73.96	53.96	-9.52
3035.42	1.00	215	10.60	45.60	---	73.96	53.96	-8.36
4877.50	1.00	152	3.97	43.08	---	73.96	53.96	-10.88
7318.33	1.00	350	10.31	44.09	---	73.96	53.96	-9.87
9747.08	1.00	95	11.89	47.16	---	73.96	53.96	-6.80
12187.92	1.00	36	9.74	48.84	---	73.96	53.96	-5.12

Table 21 Test mode: Channel 6, 802.11g for 1GHz to 25GHz [Vertical]

Radiated Emission				Corrected Amplitude		FCC Class B (3m)		
Frequency (MHz)	Ant. H. (m)	Table ()	Correction Factors (dB)	(dBµV/m)		Limit (dBµV/m)		Margin (dB)
				Peak	Average	Peak	Ave.	
1802.08	1.00	211	11.18	49.01	---	73.96	53.96	-4.95
2785.42	1.00	291	10.03	44.69	---	73.96	53.96	-9.27
4877.50	1.00	345	3.97	42.41	---	73.96	53.96	-11.55
7318.33	1.00	0	10.31	44.42	---	73.96	53.96	-9.54
9747.08	1.00	75	11.89	46.99	---	73.96	53.96	-6.97
12187.92	1.00	82	9.74	48.01	---	73.96	53.96	-5.95

Table 22 Test mode: Channel 11, 802.11g for 1GHz to 25GHz [Horizontal]

Radiated Emission				Corrected Amplitude		FCC Class B (3m)		
Frequency (MHz)	Ant. H. (m)	Table ()	Correction Factors (dB)	(dBμV/m)		Limit (dBμV/m)		Margin (dB)
				Peak	Average	Peak	Ave.	
4925.83	1.00	345	4.13	42.24	---	73.96	53.96	-11.72
7384.79	1.00	227	10.42	46.53	---	73.96	53.96	-7.43
9849.79	1.00	45	11.93	48.54	---	73.96	53.96	-5.42

Table 23 Test mode: Channel 11, 802.11g for 1GHz to 25GHz [Vertical]

Radiated Emission				Corrected Amplitude		FCC Class B (3m)		
Frequency (MHz)	Ant. H. (m)	Table ()	Correction Factors (dB)	(dBμV/m)		Limit (dBμV/m)		Margin (dB)
				Peak	Average	Peak	Ave.	
4925.83	1.00	297	4.13	42.57	---	73.96	53.96	-11.39
7384.79	1.00	59	10.42	46.86	---	73.96	53.96	-7.10
9849.79	1.00	28	11.93	48.04	---	73.96	53.96	-5.92

8.4 Test Result of the Bandedge

If any 100 kHz bandwidth outside these frequency bands, the radio frequency power that is produced by the modulation products of the spreading sequence, the information sequence and the carrier frequency shall be *at least 20 dB below that in any 100 kHz bandwidth within the band that contains the highest level of the desired power or shall not exceed the general levels specified in § 15.209(a)*,

We perform this section by the *radiated manner*, the RBW is set to 100kHz and VBW>RBW. We'd made the observation *up to 10th harmonics and the criterion is all the harmonic/spurious emissions must be 20dB below the highest emission level measured*. If the emissions fall in the restricted bands stated in the Part15.205(a) must also *comply with the radiated emission limits specified in Part15.209(a)*.
(Peak mode: RBW=VBW=1MHz, Average mode: RBW=1MHz; VBW=10Hz)

The following pages show our observations referring to the channel 1 and 11 respectively.

Test Condition & Setup: same as < 8.1 >

Channel 1, 802.11b

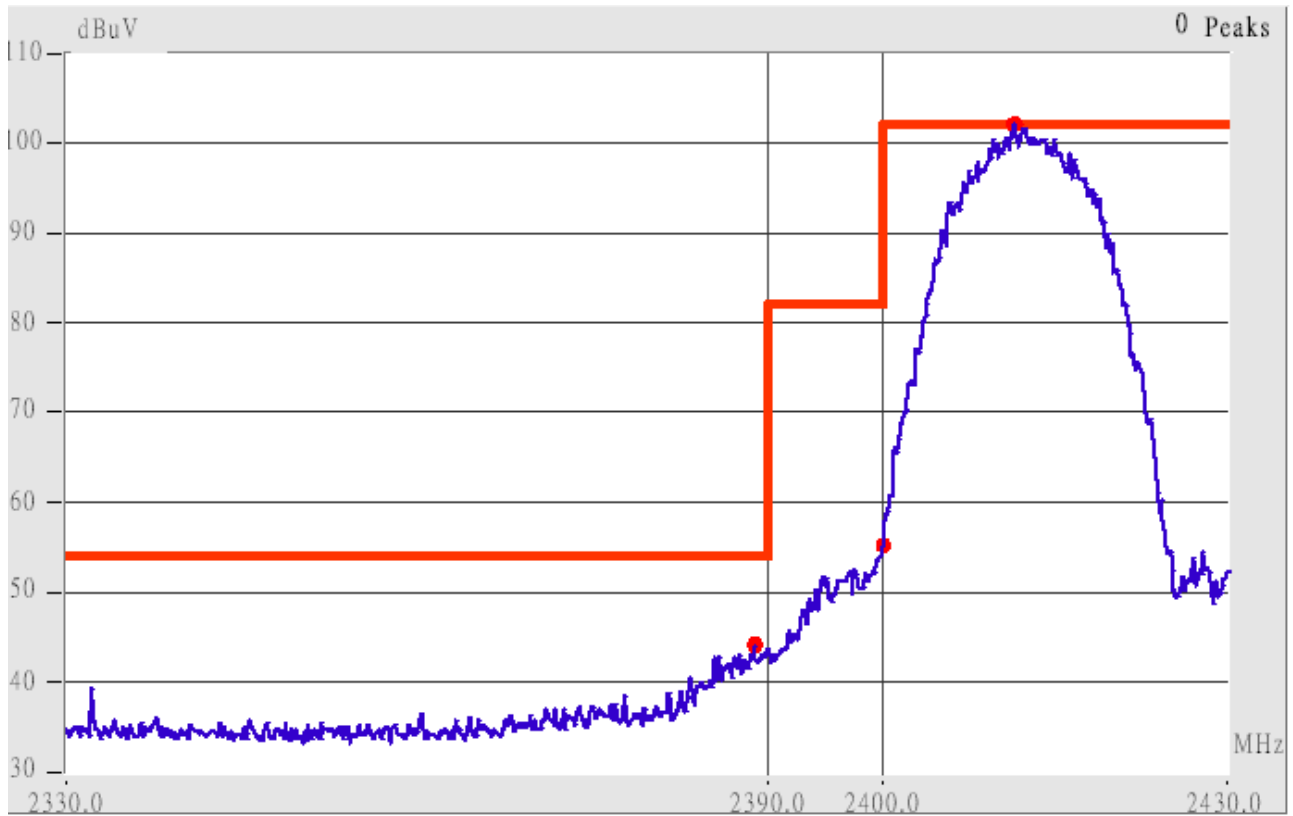

This is the hard copy of our bandedge measurement generated by our bandedge testing program. The plot shown above is the bandedge of channel 1.

1. The lobe left by the fundamental side is already 20dB below the highest emission level.
2. The emissions recorded in the restricted band is do comply with the Part 15.209(a) – as below.

Radiated Emission					Corrected Amplitude		FCC Class B (3m)		
Frequency (MHz)	Ant. P.	Ant. H. (m)	Table ()	Factors (dB)	(dBµV/m)		Limit (dBµV/m)		Margin (dB)
					Peak	Average	Peak	Ave.	
2386.44	Hor	1.00	88	9.17	46.67	---	73.96	53.96	-7.29
2390.02	Hor	1.00	191	9.18	45.35	---	73.96	53.96	-8.61
2387.90	Ver	1.00	10	9.18	53.01	---	73.96	53.96	-0.95
2390.02	Ver	1.00	10	9.18	52.52	---	73.96	53.96	-1.44

Channel 11, 802.11b

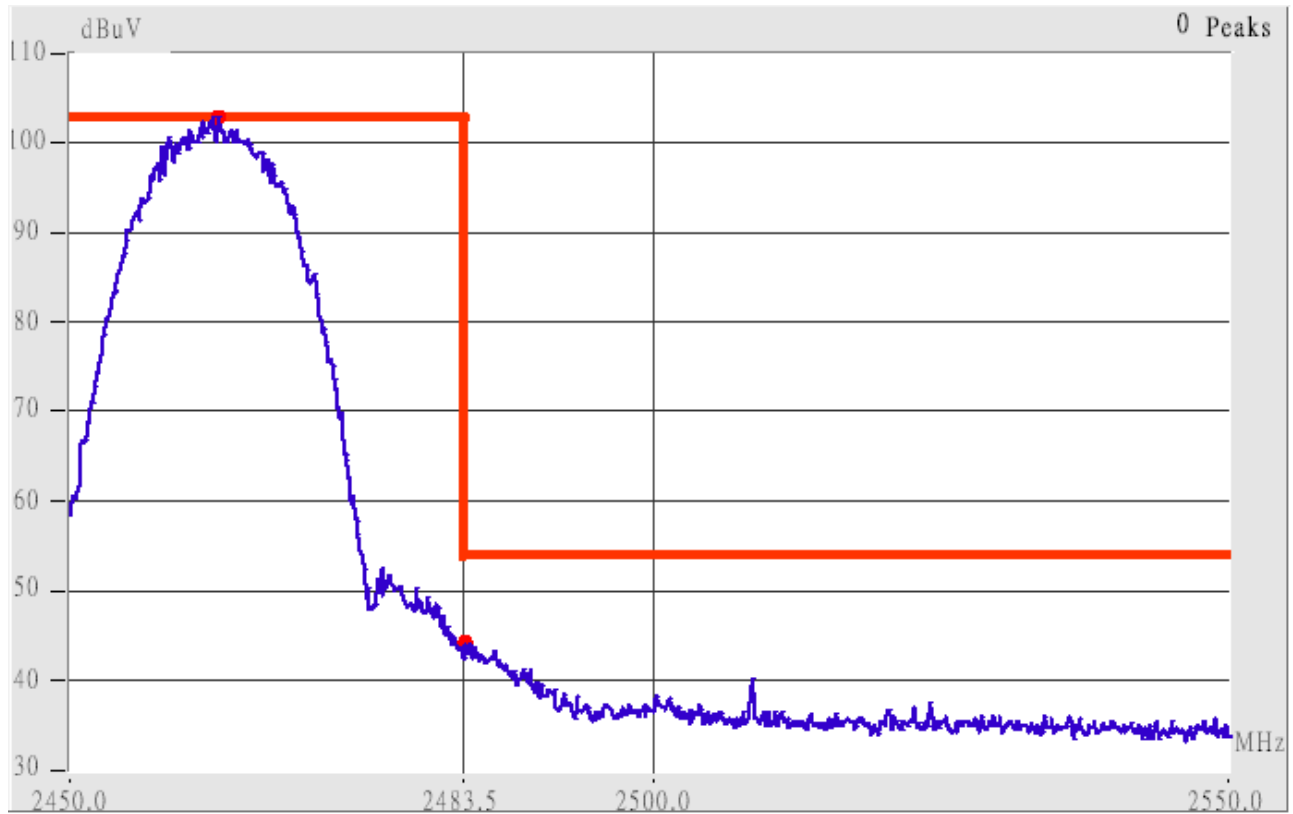

This is the hard copy of our bandedge measurement generated by our bandedge testing program. The plot shown above is the bandedge of channel 11.

1. The lobe right by the fundamental side is already 20dB below the highest emission level.
2. The emissions recorded in the restricted band is do comply with the Part 15.209(a) – as below

<i>Radiated Emission</i>					<i>Corrected Amplitude</i>		<i>FCC Class B (3m)</i>		
<i>Frequency (MHz)</i>	<i>Ant. P.</i>	<i>Ant. H. (m)</i>	<i>Table ()</i>	<i>Factors (dB)</i>	<i>(dBμV/m)</i>		<i>Limit (dBμV/m)</i>		<i>Margin (dB)</i>
					<i>Peak</i>	<i>Average</i>	<i>Peak</i>	<i>Ave.</i>	
2483.50	Hor	1.00	314	9.44	46.11	---	73.96	53.96	-7.85
2487.29	Hor	1.00	228	9.45	45.79	---	73.96	53.96	-8.17
2500.01	Hor	1.00	158	9.49	44.66	---	73.96	53.96	-9.30
2483.45	Ver	1.00	0	9.44	55.11	42.94	73.96	53.96	-11.02
2484.67	Ver	1.00	0	9.45	55.45	42.45	73.96	53.96	-11.51
2500.01	Ver	1.00	0	9.49	46.82	---	73.96	53.96	-7.14

Channel 1, 802.11g

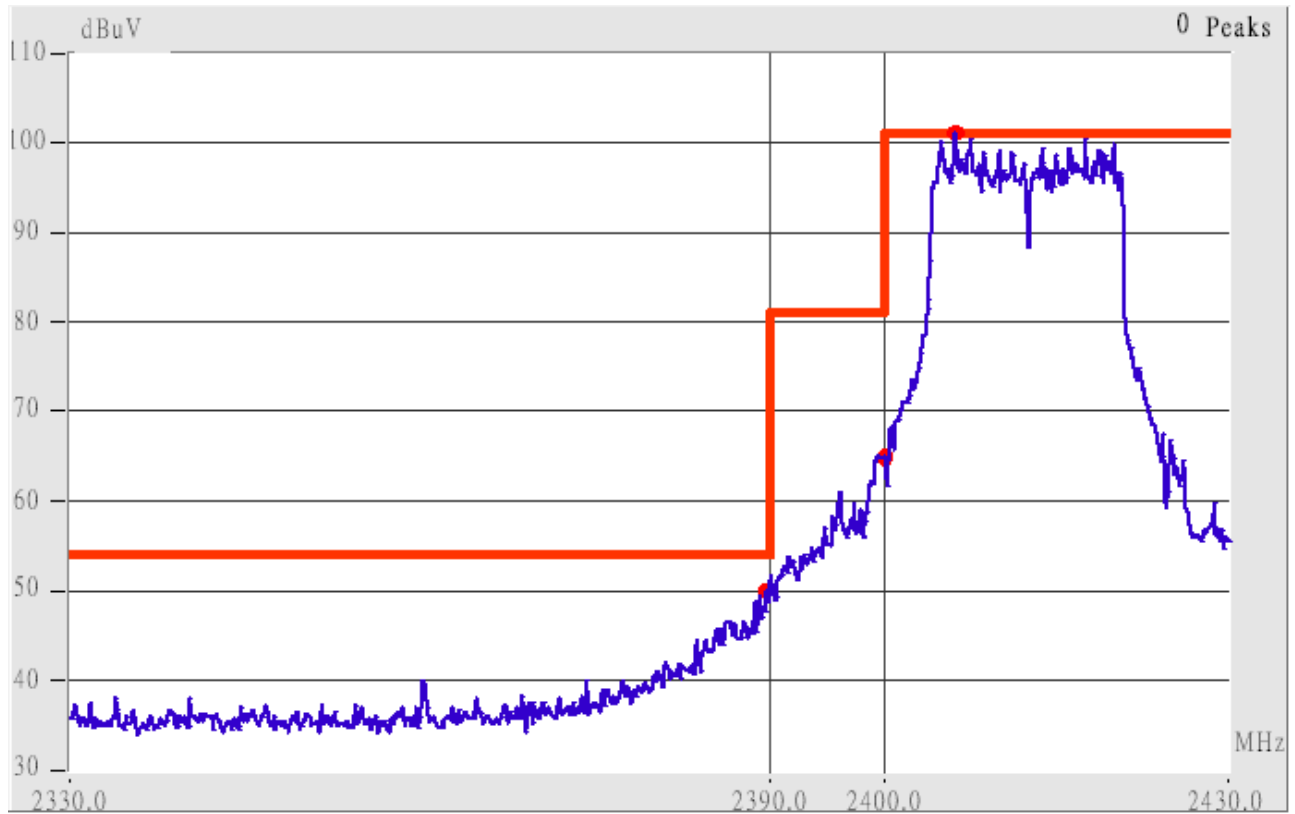

This is the hard copy of our bandedge measurement generated by our bandedge testing program. The plot shown above is the bandedge of channel 1.

1. The lobe left by the fundamental side is already 20dB below the highest emission level.
2. The emissions recorded in the restricted band is do comply with the Part 15.209(a) – as below.

<i>Radiated Emission</i>					<i>Corrected Amplitude</i>		<i>FCC Class B (3m)</i>		
<i>Frequency (MHz)</i>	<i>Ant. P.</i>	<i>Ant. H. (m)</i>	<i>Table ()</i>	<i>Factors (dB)</i>	<i>(dBµV/m)</i>		<i>Limit (dBµV/m)</i>		<i>Margin (dB)</i>
					<i>Peak</i>	<i>Average</i>	<i>Peak</i>	<i>Ave.</i>	
2383.19	Hor	1.00	91	9.16	49.50	---	73.96	53.96	-4.46
2390.02	Hor	1.00	239	9.18	53.35	---	73.96	53.96	-0.61
2386.98	Ver	1.00	285	9.17	63.17	---	73.96	53.96	-10.79
2390.11	Ver	1.00	267	9.18	62.02	---	73.96	53.96	-11.94

Channel 11, 802.11g

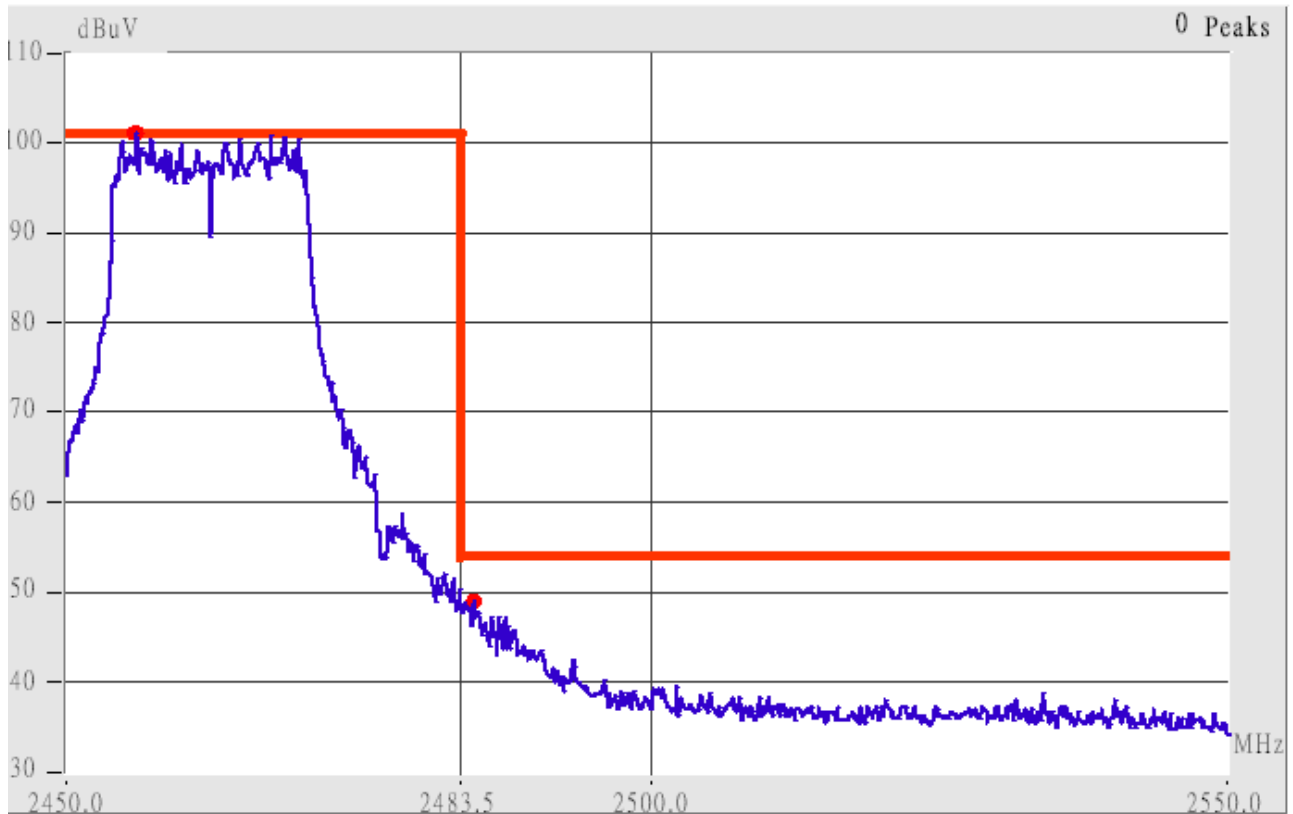

This is the hard copy of our bandedge measurement generated by our bandedge testing program. The plot shown above is the bandedge of channel 11.

1. The lobe right by the fundamental side is already 20dB below the highest emission level.
2. The emissions recorded in the restricted band is do comply with the Part 15.209(a) – as below

<i>Radiated Emission</i>					<i>Corrected Amplitude</i>		<i>FCC Class B (3m)</i>		
<i>Frequency (MHz)</i>	<i>Ant. P.</i>	<i>Ant. H. (m)</i>	<i>Table ()</i>	<i>Factors (dB)</i>	<i>(dBµV/m)</i>		<i>Limit (dBµV/m)</i>		<i>Margin (dB)</i>
					<i>Peak</i>	<i>Average</i>	<i>Peak</i>	<i>Ave.</i>	
2483.50	Hor	1.00	355	9.44	52.61	---	73.96	53.96	-1.35
2484.18	Hor	1.00	143	9.45	55.78	35.28	73.96	53.96	-18.18
2500.01	Ver	1.00	87	9.49	43.99	---	73.96	53.96	-9.97
2483.91	Ver	1.00	318	9.44	61.44	40.61	73.96	53.96	-12.52
2486.96	Ver	1.00	52	9.45	63.95	39.78	73.96	53.96	-10.01
2500.01	Ver	1.00	302	9.49	47.66	---	73.96	53.96	-6.30

IX. Section 15.247(d): Power Spectral Density

9.1 Test Condition & Setup

The tests below are running with the EUT transmitter set at high power in TDD mode. The EUT is needed to force selection of output power level and channel number. While testing, the EUT was set to transmit continuously and to be tested by the contact manner with the spectrum analyzer.

9.2 Test Instruments Configuration

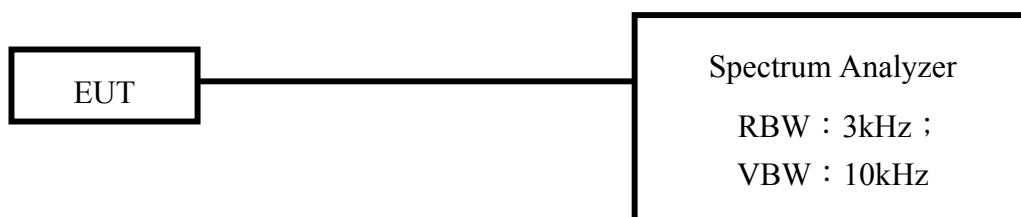

P.S.: Notebook computer to control the EUT at maximal power output and channel Number and set antenna kit

9.3 List of Test Instruments

Instrument Name	Model No.	Brand	Serial No.	Last time	Next time
Spectrum Analyzer	MS2665C	ANRITSU	6200175476	09/11/03	09/11/04

9.4 Test Result of Power spectral density

The following table shows a summary of the test results of the Power Spectral Density.

802.11b

<i>Channel</i>	<i>Frequency (GHz)</i>	<i>Ppr (dBm)</i>	<i>Cable Loss (dB)</i>	<i>Ppq (dBm)</i>	<i>Limit (dB)</i>	<i>Margin (dB)</i>
CH 01	2.412	-12.85	0.50	-12.35	8.00	-20.35
CH 06	2.437	-14.41	0.50	-13.91	8.00	-21.91
CH 11	2.462	-11.48	0.50	-10.98	8.00	-18.98

802.11g

<i>Channel</i>	<i>Frequency (GHz)</i>	<i>Ppr (dBm)</i>	<i>Cable Loss (dB)</i>	<i>Ppq (dBm)</i>	<i>Limit (dB)</i>	<i>Margin (dB)</i>
CH 01	2.412	-13.05	0.50	-12.55	8.00	-20.55
CH 06	2.437	-12.30	0.50	-11.80	8.00	-19.80
CH 11	2.462	-14.13	0.50	-13.63	8.00	-21.63

Note:

1. The following pages show the results of spectrum reading.
2. Ppr: spectrum read power density (using peak search mode),
Ppq: actual peak power density in the spread spectrum band.
3. $Ppq = Ppr + |Cable Loss|$

Channel 01

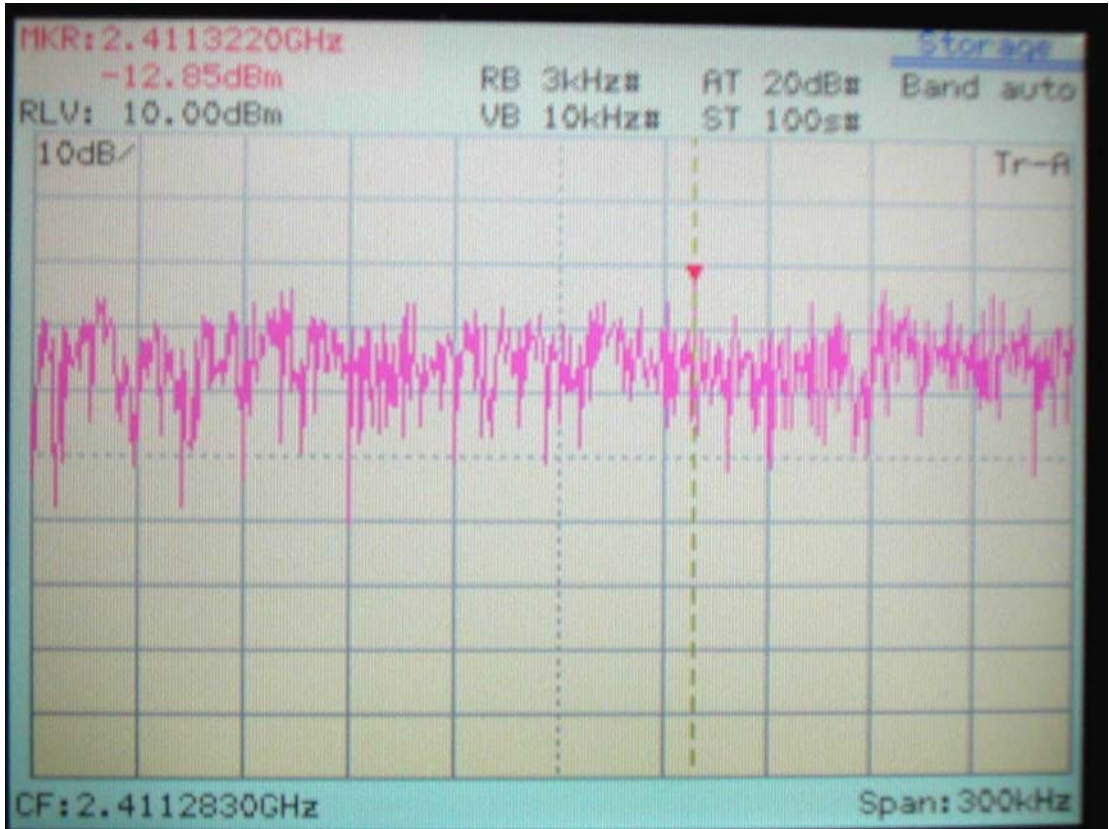

802.11b

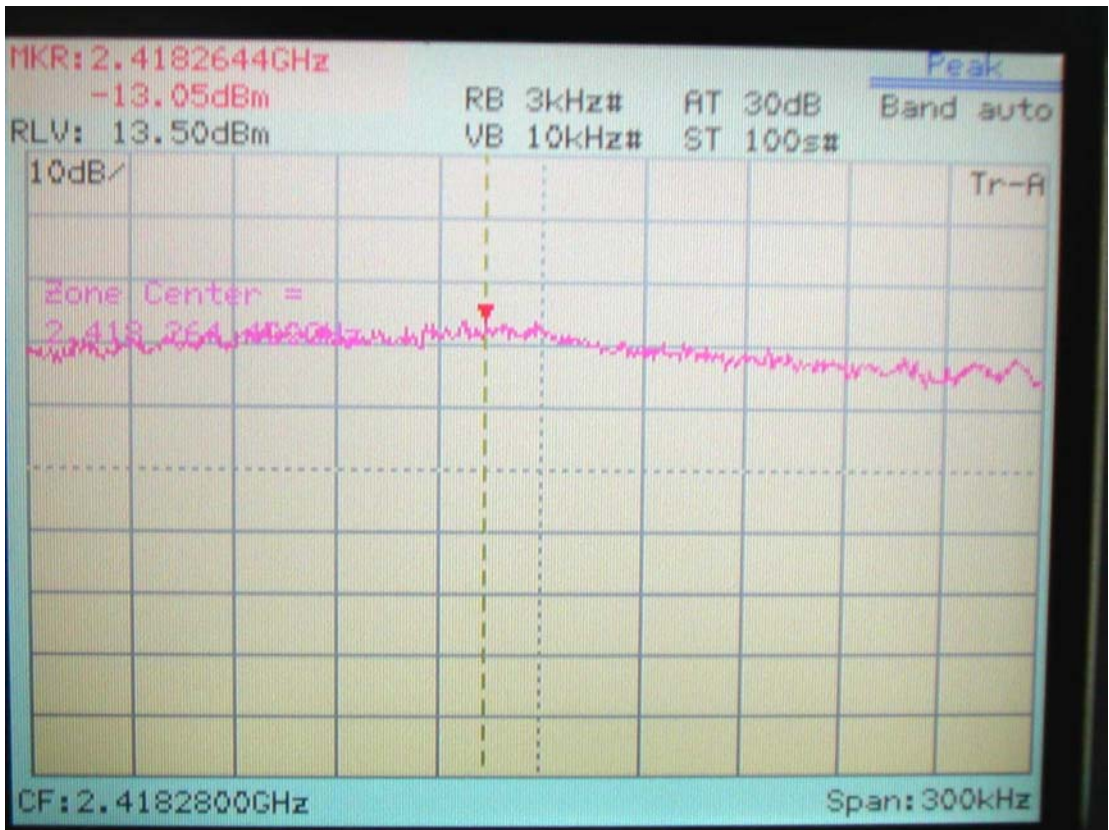

802.11g

Channel 06

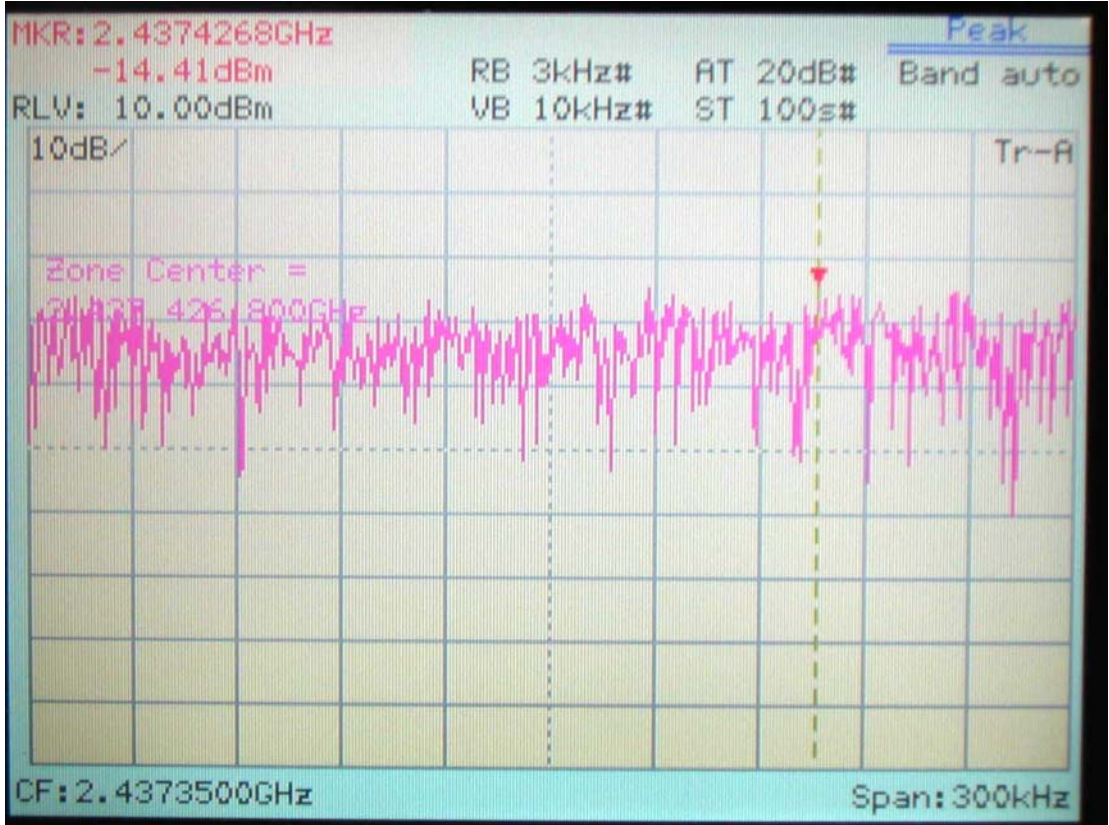

802.11b

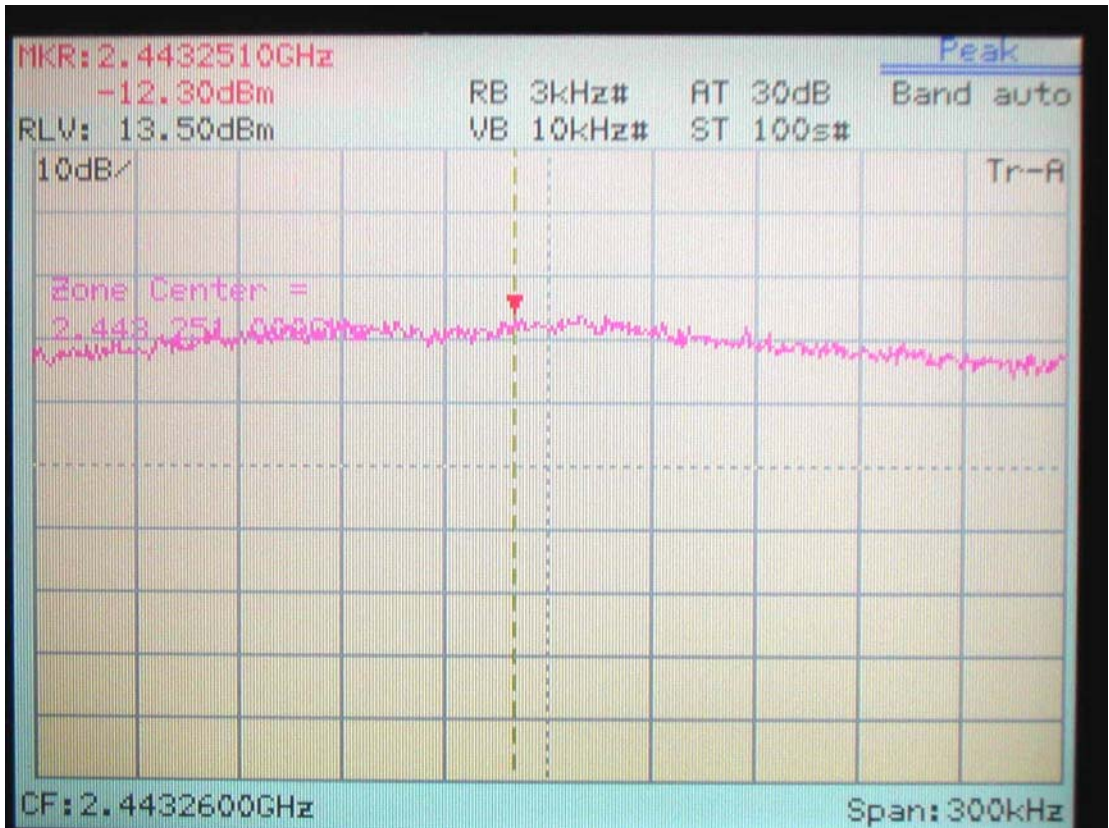

802.11g

Channel 11

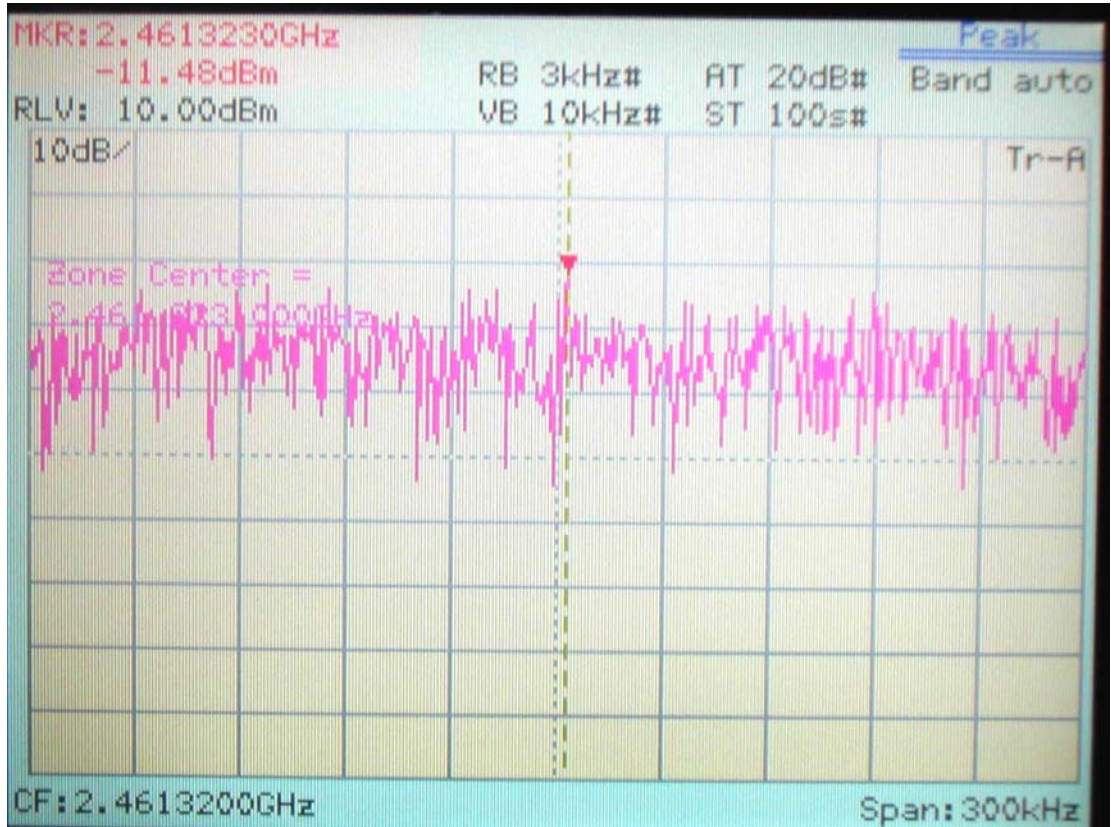

802.11b

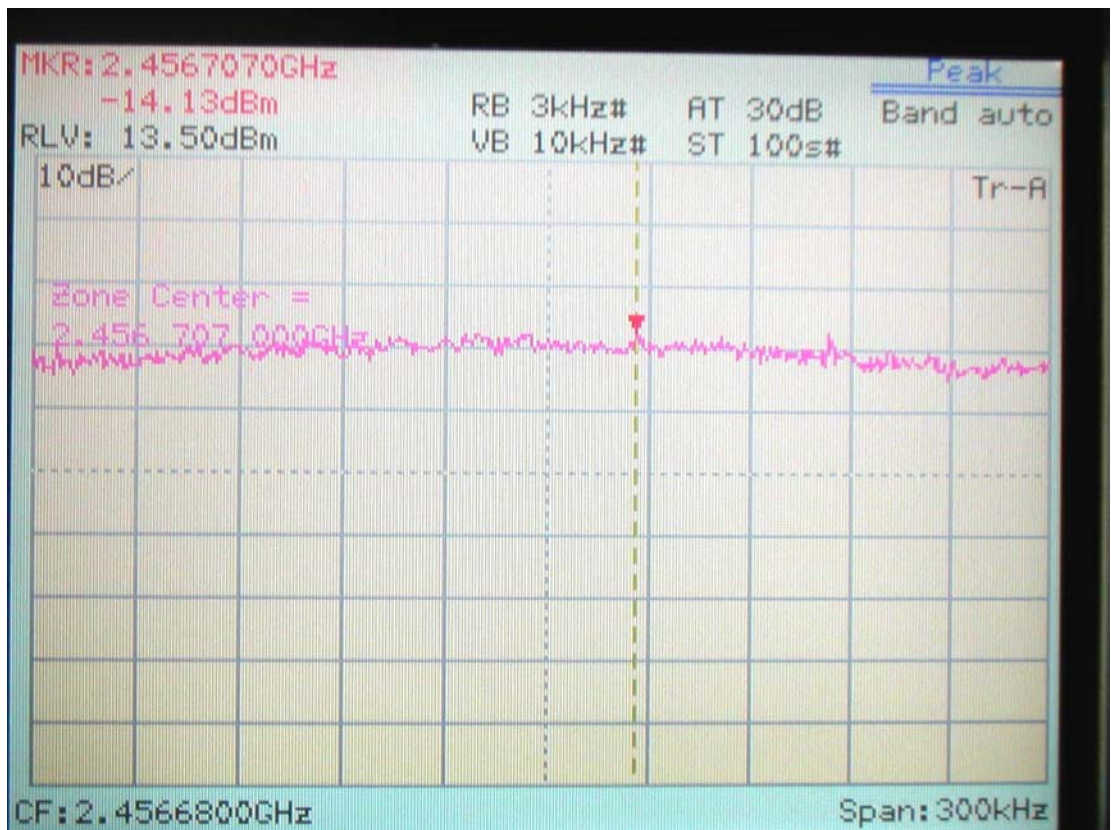

802.11g



