

Test setup photos

USI Bluetooth USB Dongle (Test report no.:U1315806)

FCC ID: IXMUD23011

Test Instruments Configuration of Conducted Emissions



Configuration of test of carrier frequency separation

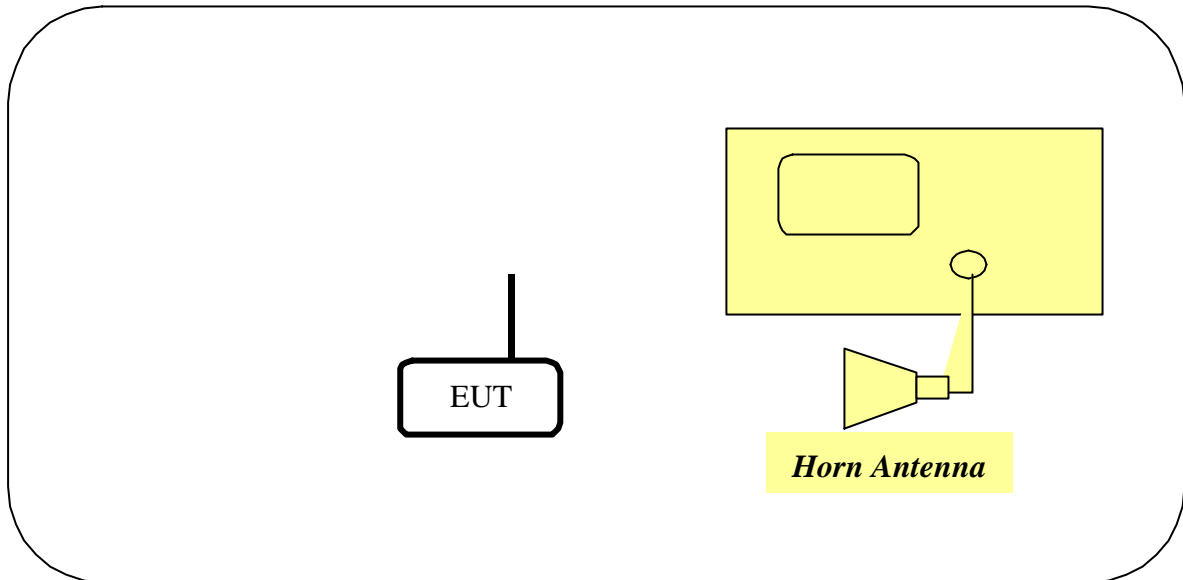

Configuration of test of number of hopping frequency

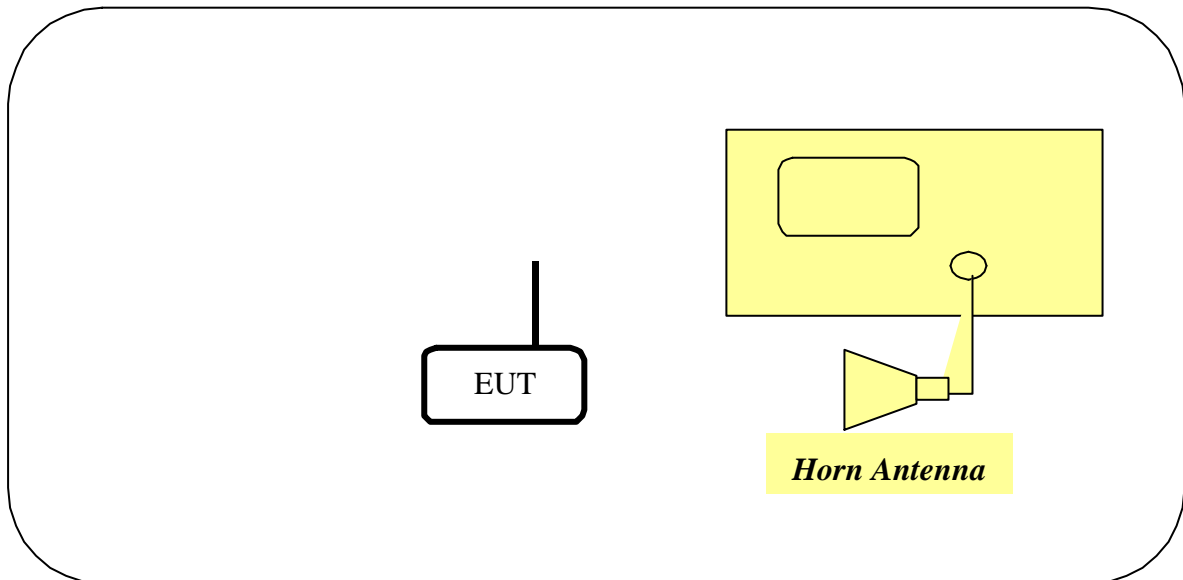

Configuration of test of time of occupancy (Dwell time)

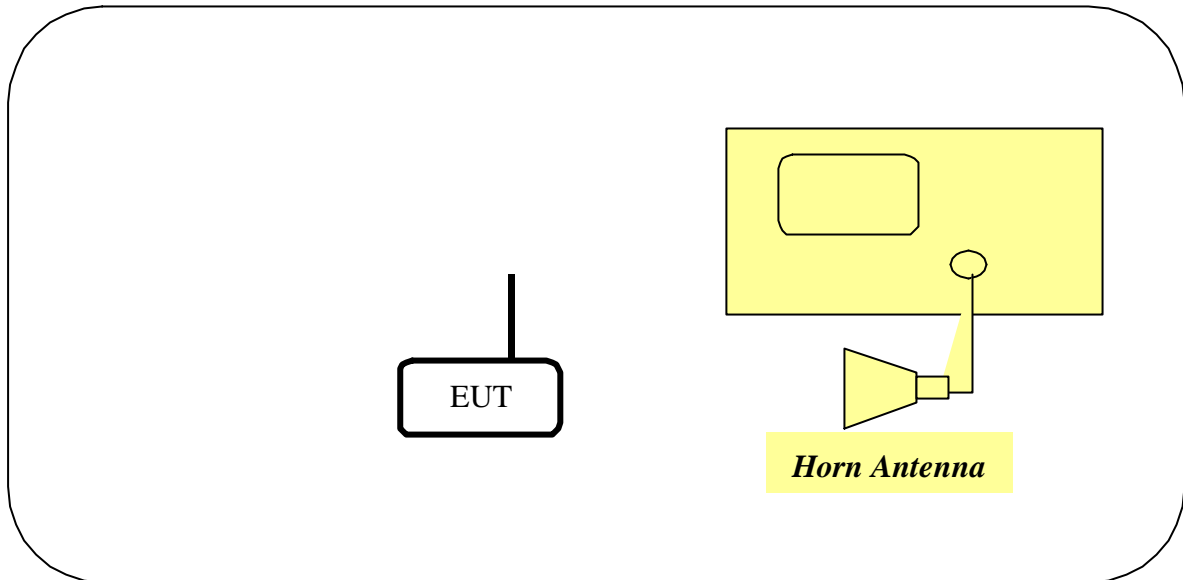

Configuration of test of 20dB bandwidth

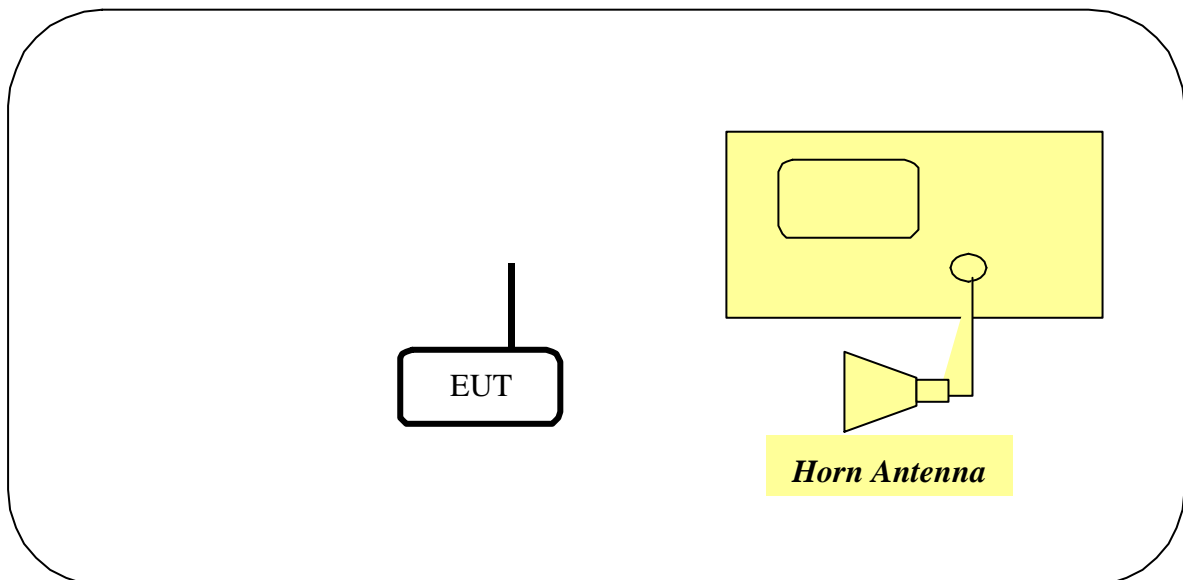

Test Setup of Power Output



Test Setup of bandedge compliance

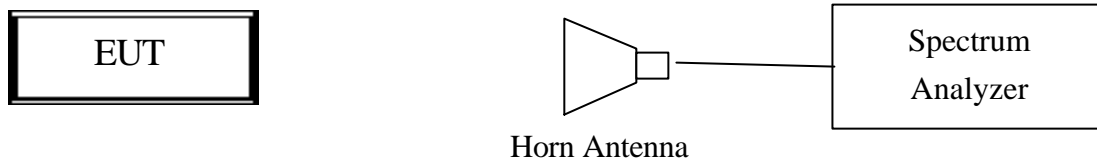

Test Instruments Configuration of the Spurious Radiated Emissions

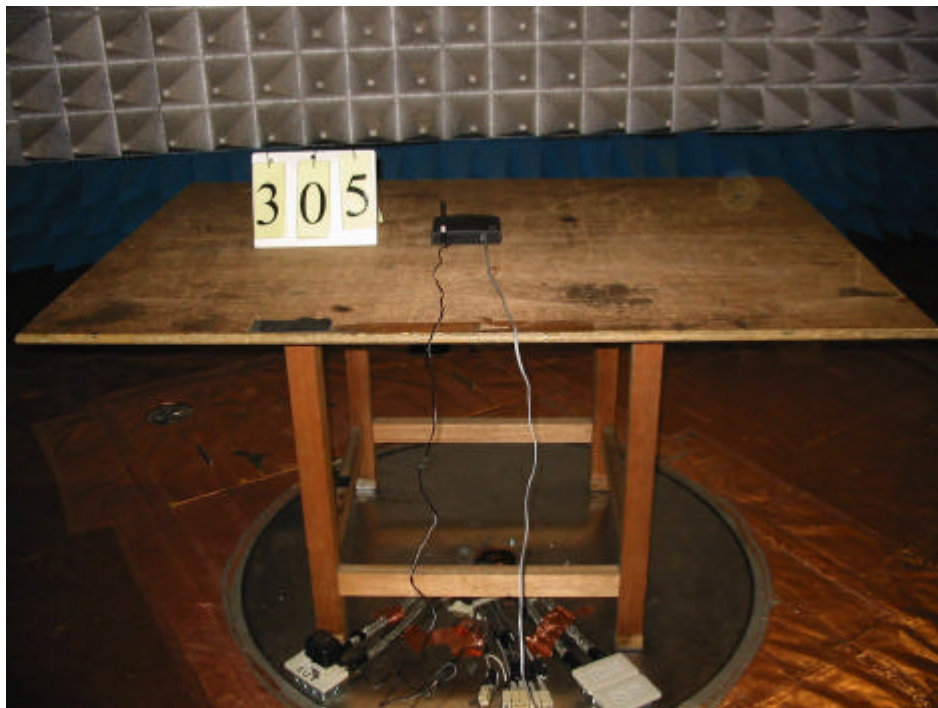

Front View of the Test Configuration



Rear View of the Test Configuration

The test configuration for frequency between 1GHz to 18GHz is same as above.