

EXHIBIT B

Test Report

Report No.	W0115277	
Specifications	FCC Part 15.109(g), CISPR 22	
Test Method	ANSI C63.4 1992	
Applicant address	4F, NO. 539-2, CHUNG CHENG RD., HSIN TIEN, TAIPEI, TAIWAN, R.O.C.	
Applicant Items tested	WELL COMMUNICATION CO., 56K Fax/Data/Voice modem card	
Model No.	FM-56PCI-RW (Sample # W01277)	
Results	As detailed within this report	
Sample received data	04/20/1998 (month / day / year)	
Prepared by	<u>Robert Chang.</u>	project engineer
Authorized by	<u>Jacob Lin</u>	Vice General Manager (Jacob Lin)
Issue date	<u>Apr. 29, 1998</u>	(month / day / year)
Modifications	Appendix C	
Tested by	Training Research Co., Ltd.	
Office at	2F, No. 571, Chung Hsiao E. Road, Sec.7, Taipei, Taiwan	
Open site at	No. 5-3, Lane 21, Yen Chiu Yuan Rd., Sec. 4, Taipei, Taiwan	

Conditions of issue:

- (1) **This test report shall not be reproduced except in full, without written approval of TRC. And the test result contained within this report only relate to the sample submitted for testing.**
- (2) **This report must not be used by the client to claim product endorsement by NVLAP or any agency of U.S. Government.**

★ FCC ID : JCH-FM56PCIRW

Contents

Chapter 1 Introduction

Description of EUT 3
 Configuration of Test Setup 4
 List of Support Equipment 5

Chapter 2 Conducted Emission Test

Test Condition and Setup 7
 Conducted Test Placement 8

Chapter 3 Radiated Emission Test

Test Condition and Setup 9
 Radiated Test Placement 10

Appendix A:

Conducted test result 11

Appendix B:

Radiated test result 12

Appendix C:

List of Modifications 14

Chapter 1 Introduction

Description of EUT:

This Fax/Data/Voice modem card is a data communication device. It is designed to be installed in a personal computer and makes your data equipment available to transmit and receive data via the public telephone network.

Connections of EUT:

- (1) Put the EUT into a personal computer's bus and screw it.
- (2) Line jack of EUT connects with a line cable to the PABX located remotely.
- (3) Phone jack of EUT connects with a telephone set.
- (4) Spk jack of EUT connects with a pair of speakers.
- (5) Mic jack of EUT connects with a microphone.

Test method:

Pretest was found that the emission of operating mode is worse than standby mode. So, The final test is made at the operating mode.

During testing, the EUT was operated at "transmitting" and "receiving" mode simultaneously.

While testing, the transmitting rate was set to "AUTO" which means it transmitted the test file depending on the telephone line condition, normally the operating rate is the highest speed. The test placement as the photographs showed is the worst case emission placement. (If the emission is close to the ambience, the resolution BW and view resolution will be reduced and the data will be recorded by detection of maximum hold peak mode.)

The testing configuration of test setup is showing in the next page.

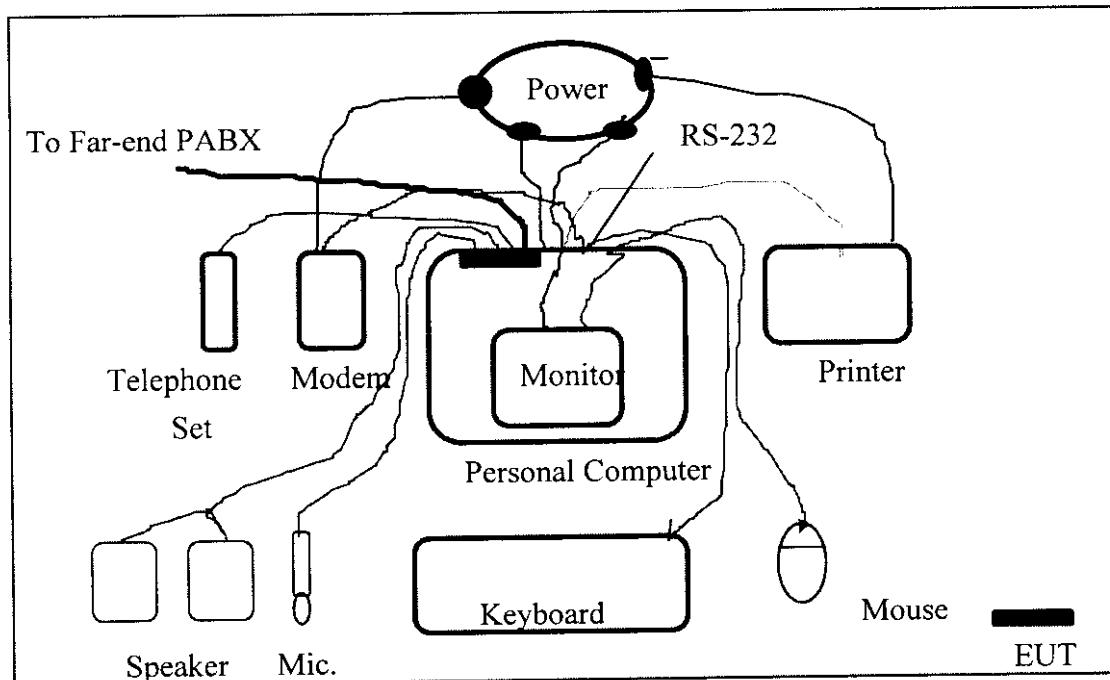
Configuration of test setup**Connections:****PC:**

- *Serial A port --- a external modem
 - *Serial B port --- a 76 cm shielded RS232 cable
 - *Printer port --- a Printer
 - *Keyboard port --- a Keyboard
 - *Mouse port --- a Mouse
 - *Monitor port --- a monitor
- (Each port on PC is connected with suitable device)

EUT:

- *Line jack --- via 15 m RJ11C cable to PABX located remotely
- *Phone jack --- via a 7 feet RJ11C cable to telephone set
- *Spk. jack --- a pairs of speakers with 1.2 m long wire
- *Mic. Jack --- a dynamic microphone with 3 m long wire

List of support equipment

Conducted (Radiated) test:

PC : **HP**
Model : Vectra VE2
Serial No. : SG61803151 (SG61802786)
FCC ID : HCJVECTRAVL5
Power type : AC 117 VAC, switching
Power cord : non-Shielded, 1.7m long, Plastic, no ferrite core

Monitor : **HP**
Model No. : D2084 (D2813)
Serial No. : KR4397004 (TW63803597)
FCC ID : CSYSC-428VSP (A3KM043)
Power type : 117VAC, Switching
Power cord : Non-Shielded, 3m long, no ferrite core
Data cable : Shielded, 1.8m long, with ferrite core

Keyboard : **HP**
Model No. : C3757 #ABO (C3346A #ABO)
Serial No. : C3757-60423 (C3346-60231)
FCC ID : CIGE03614
Power type : By PC
Data cable : Shielded, 1.8m long, with ferrite core

Printer : **EPSON**
Model No. : P78PA (P70RA)
Serial No. : 0EE0014030 (10010386)
FCC ID : BKM9A8P70RA
Power type : Linear
Power cord : Non-shielded, 2m long, no ferrite core
Data cable : Shielded, 1.84m long, no ferrite core (1.7m)

Modem : **ACEEX**
Model No. : XDM-9624
FCC ID : IFAXDM-9624
Power type : Linear
Power cord : Non-shielded, 1.9m long, no ferrite cord
Data cable : RS232, Shielded, 1.2m long, no ferrite core
RJ11C x 2, 7' long non-shielded, no ferrite core

PABX : **King Design**
Model No. : KD8705-A
Serial No. : GV101101186
Power type : 110 VAC 50/60Hz
Power cord : Non - Shielded

Microphone : **KOKA**
Model : DM-515
Power type : Dynamic
Data cable : non-Shielded, 3m

Speaker : **J-S**
Model : J-006
Data cable : non-Shielded, 1.2 m

Mouse : **Hewlett Packard mouse**
Model No. : C3751B
Serial No. : LCA52707170
FCC ID : DZL210582
Power type : Powered by PC
Power Cable : Non – Shielded. 5.5' long, Plastic hoods, No ferrite bead

Chapter 2 Conducted emission test

Test condition and setup:

All the equipment is placed and setup according to the EN 55022. The EUT is assembled on a wooden table, which is 80 cm high, is placed 40 cm from the back-wall which is a vertical conducting plane. One LISN is for EUT, the other LISN is for support equipment. They are all placed on the conductive ground. The EUT's LISN connect a line switch box for selecting L1 or L2, then connect to a preamplifier and spectrum.

The spectrum scans from 150KHz to 30MHz. Conducted emission levels are detected at max. Peak mode. But if the max. Peak mode failed, it will be measured by CISPR's quasi-peak detection mode.

While testing, there is a worst-emission plot printed at peak detection mode, and there are more than 6 highest emissions relative to limit recorded. The plot is kept as the original data, not included in test report.

List of test Instrument:

Instrument Name	Model No.	Brand	Serial No.	Calibration Date	
				last time	Next time
Spectrum analyzer	8591EM	H P	3619A00821	10/06/97	10/06/98
LISN (EUT)	3825/2	EMCO	9411-2284	05/15/97	05/15/98
Preamplifier	8447F	H P	2944A03706	05/13/97	05/15/98
Line switch box	AC1-003	TRC	-----	05/15/97	05/15/98
Line selector	AC1-002	TRC	-- ----	05/15/97	05/15/98

The level of confidence of 95%, the uncertainty of measurement of conducted emission is ± 2.4 dB.

Test Result: Pass (Appendix A)

Chapter 3 Radiated emission test

Test condition and setup:

Pretest: Prior to the final test (OATS test), the EUT is placed in a shielded enclosure, GTEM, and scan from 30MHz to 1GHz. This is done to ensure the radiation exactly emits from the EUT.

Final test: Final radiation measurements is made on a **10 - meter**, open-field test site. The EUT is placed on a nonconductive table which is 0.8 m height, the top surface is 1.0 x 1.5 meter. All the placement is according to EN 55022.

The spectrum is examined from 30 MHz to 1000 MHz measured by HP spectrum.

The EMCO whole range Antenna is used to measure frequency from 30 MHz to 1GHz. The final test is used the spectrum HP 8594EM.

Measure more than six top marked frequencies generated from pretest by computer step by step at each frequency. The EUT is rotated 360 degrees, and antenna is raised and lowered from 1 to 4 meters to find the maximum emission levels. The antenna is used with both horizontal and vertical polarization.

Appropriated preamplifier which is made by TRC is used for improving sensitivity and precautions is taken to avoid overloading. The spectrum analyzer's 6dB bandwidth is set to 120 KHz, and the EUT is measured at quasi-peak mode.

If the emission is close to the frequency band of ambient, the data will be rechecked by the tester and the corrected data will be written on the test data sheet. If the emission is just within the ambience, the data from GTEM will be taken as the final data.

List of test Instrument:

Calibration Date

Instrument Name	Model No.	Brand	Serial No.	Last	Next
Spectrum analyzer	8568B	H P	3004A18617	05/15/97	05/15/98
Quasi-peak Adapter	85650A	H P	2521A00984	05/15/97	05/15/98
RF Pre-selector	85685A	H P	2947A01011	05/15/97	05/15/98
Spectrum analyzer	8594EM	H P	3619A00198	08/13/97	08/13/98
Antenna (30M-2G Hz)	3141	EMCO	9610-1094	10/30/97	10/30/98
Open test side (Antenna, Amplify, cable calibrated together)				05/15/97	05/15/98

The level of confidence of 95%, the uncertainty of measurement of radiated emission is ± 4.96 dB.

Test Result: Pass (Appendix B)

Appendix A

Conducted Emission Test Result :

Testing room : Temperature : 22 ° C Humidity : 85 % RH

Line 1

<i>Frequency (MHz)</i>	<i>Amplitude (dBuV)</i>	<i>Limit (dBuV/m)</i>	<i>Margin (dB)</i>
1.344	37.10	46.00	-8.90
9.232	36.12	50.00	-13.88
10.494	37.96	50.00	-12.04
11.977	38.78	50.00	-11.22
13.386	36.58	50.00	-13.42
15.163	38.02	50.00	-11.98
17.160	38.44	50.00	-11.56
18.343	36.94	50.00	-13.06
21.886	37.43	50.00	-12.57
23.876	38.20	50.00	-11.80

Line 2

<i>Frequency (MHz)</i>	<i>Amplitude (dBuV)</i>	<i>Limit (dBuV)</i>	<i>Margin (dB)</i>
10.494	35.90	50.00	-14.10
11.162	38.36	50.00	-11.64
11.310	39.09	50.00	-10.91
12.052	36.90	50.00	-13.10
13.312	36.43	50.00	-13.57
14.645	36.33	50.00	-13.67
15.163	36.20	50.00	-13.80
22.919	35.68	50.00	-14.32
24.024	36.87	50.00	-13.13
24.613	35.62	50.00	-14.38

* The reading amplitudes are all under average limit.

Appendix B

Radiated Emission Test Result :(Horizontal)

Test Conditions:

Testing room : Temperature: 23° C Humidity : 59 % RH
 Testing site : Temperature: 24° C Humidity : 80 % RH

Frequency	Reading Amplitude	Ant. Height	Table	Correction Factors	Corrected Amplitude	Class B limit	Margin
MHz	dBuV	m	degree	dB/m	dBuV/m	dBuV/m	dB

112.895	41.12	4.01	118	-14.09	27.03	30.00	-2.97
169.342	38.27	4.01	0	-11.40	26.87	30.00	-3.13
232.106	38.86	4.01	146	-8.33	30.53	37.00	-6.47
254.012	39.70	1.00	63	-7.38	32.32	37.00	-4.68
366.906	40.00	1.00	346	-16.98	23.02	37.00	-13.98
179.801	41.96	4.01	323	-14.75	27.21	37.00	-9.79
592.695	39.26	1.00	83	-10.45	28.81	37.00	-8.19
762.036	38.95	4.01	335	-5.56	33.39	37.00	-3.61

Note:

1. Margin = Amplitude - limit, *if margin is minus means under limit.*
 2. Corrected Amplitude = Reading Amplitude + Correction Factors
 3. Correction factor = Antenna factor + (Cable Loss - Amplitude gain)
- (For example : 30MHz correction factor = 15.5 + (-15.26) = 0.24 dB/m)

Radiated Emission Test Result: (Vertical)

Frequency	Reading Amplitude	Ant. Height	Table	Correction Factors	Corrected Amplitude	Class B limit	Margin
MHz	DBuV	m	degree	dB/m	dBuV/m	dBuV/m	dB

112.895	41.44	4.01	206	-14.09	27.35	30.00	-2.65
169.342	37.50	4.01	347	-11.40	26.12	30.00	-3.88
232.106	40.86	1.00	222	-8.33	32.53	37.00	-4.47
254.012	42.05	1.00	258	-7.38	34.67	37.00	-2.33
366.906	42.64	1.00	125	-16.98	25.66	37.00	-11.34
479.801	40.28	1.00	159	-14.75	25.53	37.00	-11.47
592.695	41.11	1.00	35	-10.45	30.66	37.00	-6.34
762.036	38.74	1.00	349	-5.56	33.18	37.00	-3.82

Final statement :

This test report, measurements made by TRC are traceable to the NIST.

Appendix C

List of Modifications:

- 1. C21, C26, C43, C44 =221 (2KV).
- 2. R51 =N2012Z221 (TOKIN).

Statement of Applicant:

I acknowledge that the modifications made to the EUT for compliance during testing will be incorporated into mass production units.

Applicant: WELL COMMUNICATION CO., LTD.

By: David chun

Date: 1998/4/24

Signature

Printed

Title: Section Chief

David chun

Engineering Dept.