

ZACTA Technology Corporation Yonezawa Testing Center
4149-7 Hachimanpara 5-chome Yonezawa-shi Yamagata 992-1128 Japan
Phone: +81-238-28-2880 Fax: +81-238-28-2888

TEST REPORT

Report Number: Z01C-02310

Issue Date: September 27, 2002

The device, as described herewith, was tested pursuant to applicable test procedure indicated below and complies with the requirements of;

FCC Part 15 Subpart B, Class B

The EUT complies with section 15.37 "Transition provision for compliance with the rules".

The test results are traceable to the international or national standards.

Applicant	:	Sanyo Electric Co., Ltd. Optical Device Division 1-1-1, Sakata, Oizumi-machi Ora-gun, Gunma-ken 370-0596 Phone: +81-276-61-8006 Fax: +81-276-61-8752
Equipment under test (EUT)	:	DVD-R Drive
FCC ID	:	JBQCDR029
Trade Name	:	SANYO
Model Number	:	CRD-DV1
Serial Number	:	DV1PP2085
EUT Condition	:	Pre-production

Test procedure : ANSI C63.4-1992
Date of test : September 20, 2002
Test place : Site 1
Test results : Complied

Zacta Technology Corporation certifies that no party to the application is subject to a denial of federal benefits, that include FCC benefits, pursuant to Section 5301 of the Anti-Drug Abuse Act of 1988, 21U.S.C. 853(a).

The results in this report are applicable only to the samples tested.

This report shall not be re-produced except in full without the written approval of ZACTA Technology Corporation.

Test performed by: Hisatoshi Saito
EMC engineer

H. Saito

Authorized by: Hiroaki Suzuki
Chief Engineer

Hiro Suzuki

NVLAP[®]
NVLAP LAB CODE 200306-0

Table of contents

	Page
<i>1. Equipment description</i>	3
1.1 EUT information.....	3
1.2 Operating flow.....	3
<i>2. Configuration information</i>	4
2.1 Peripheral(s) information.....	4
2.2 Cable(s) information.....	4
2.3 System configuration.....	5
<i>3. Test procedure</i>	6
3.1 Description of Conducted Emission testing	6
3.2 Test equipment for Conducted emission.....	6
3.3 Description of Radiated emission testing.....	7
3.4 Test equipment for Radiated emission	8
<i>4. Laboratory description</i>	9
4.1 Description for Test Site.....	9
4.2 Uncertainty	10
<i>5. Results of the measurements</i>	11
5.1 Results of the measurements.....	11
5.2 Deviation from the standard.....	11
5.3 Sample of field strength calculation.....	11
<i>6. Test Data</i>	12

1. Equipment description

1.1 EUT information

No.	EUT	Company	Model No.	Serial No.	FCC ID/DoC	Comment
1	DVD-R Drive	SANYO	CRD-DV1	DV1PP2085	JBQCDR029	-

Max. used frequency : 380.00MHz (±80%)
Oscillator(s)/Crystal(s) : 20.00MHz, 33.86MHz, 380MHz(±80%)
Operating frequency
Power ratings : DC +5V, +12V
[EUT is powered from Host PC.
Power supply for Host PC in testing was AC 120V 60Hz.]
Port(s) : Headphones jack
Audio connector
IDE connector
DC connector (DC input)
Size : (W) 148 x (D) 194.2 x (H) 42.3 mm
Operating mode : CD Read mode
CD Write mode
DVD Read mode
DVD Write mode
Variation of model(s) : Not applicable

1.2 Operating flow

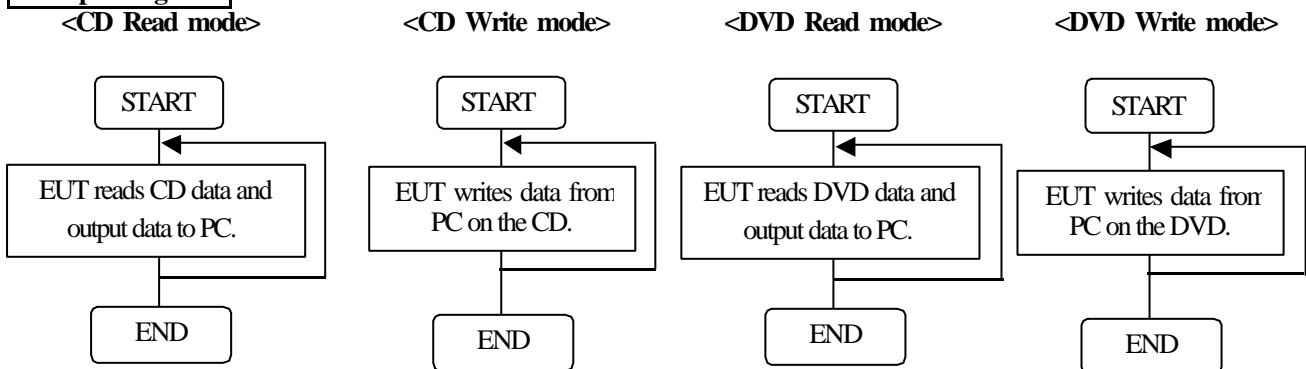

2. Configuration information

2.1 Peripheral(s) information

No.	Equipment	Company	Model No.	Serial No.	DoC / FCC ID	Comment
2	Main board	COMPAQ	N/A	N/A	N/A	-
3	Personal Computer	COMPAQ	Prosig 320 C500/ M1 JPN2	7016 CZHP0116	DoC	-
4	Headphone	N/A	N/A	N/A	N/A	-
5	Speaker	Panasonic	RP-SP30	N/A	N/A	-
6	Printer	HP	C4555A	US6BC1212N	B94C4555X	-
7	Display	Goldstar	Studio Works 56i	15005G004960	BEJCS585	-
8	Modem	US Robotics	839	000839032BK6YV4J	DoC	-
9	AC adapter for Modem	US Robotics	N/A	N/A	N/A	-
10	Keyboard	COMPAQ	KB-9965	B13B00WBUJ6150	DoC	-
11	Mouse	COMPAQ	Intelli Mouse	0805393-5	DoC	-

2.2 Cable(s) information

No.	Cable	Length [m]	Shield	Connector	From	To	Comment
a	IDE cable	0.4	Unshielded	Plastic	EUT	Main board	-
b	Audio cable	0.5	Unshielded	Plastic	EUT	Main board	-
c	DC cable	0.2	Unshielded	Plastic	EUT	Power supply	-
d	Headphone cable	1.0	Unshielded	Metal	EUT	Headphone	-
e	Speaker cable	1.0	Unshielded	Metal	PC	Speaker	-
f	Centronics cable	1.2	Shielded	Metal	PC	Printer	-
g	AC power cord for Printer	2.7	Unshielded	Plastic	Printer	AC outlet	-
h	RGB cable	1.5	Shielded	Metal	PC	Display	-
i	AC power cord for Display	2.2	Unshielded	Plastic	Display	AC outlet	-
j	RS232C cable	1.2	Shielded	Metal	PC	Modem	-
k	DC cable for Modem AC adapter	2.0	Unshielded	Metal	Modem	AC adapter	-
l	Keyboard cable	2.0	Unshielded	Metal	PC	Keyboard	-
m	Mouse cable	1.8	Unshielded	Metal	PC	Mouse	-
n	AC power cord for PC	2.0	Unshielded	Plastic	PC	AC outlet	-

2.3 System configuration

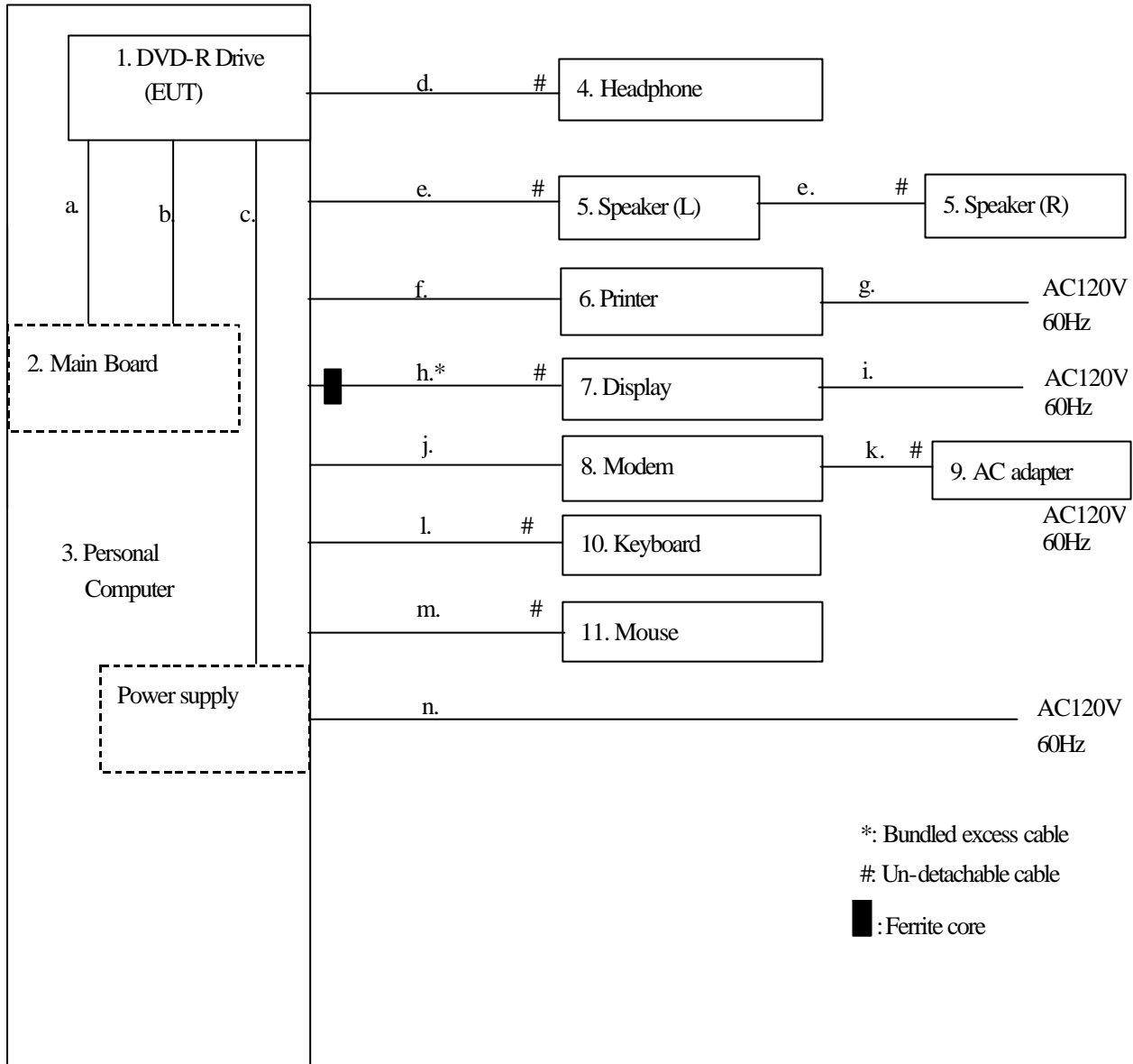

Note 1: Numbers assigned to equipment or cables on this diagram are corresponded to the list in "1.1 EUT information", "2.1 Peripheral(s) information" and "2.2 Cable(s) information".

Note 2: RGB cable(No. h) with one ferrite core is un-detachable from Display. Ferrite core is not added during testing

3. Test procedure

3.1 Description of Conducted Emission testing

The conducted emission measurements are performed with the test receiver. The detector function of the test receiver is set to CISPR quasi-peak mode and the bandwidth is set to 9kHz. The frequency range from 450kHz to 30 MHz is scanned, and at least six highest emissions are reported. The test results represent the worst-case emission for each emission with manipulating the EUT, support equipment, interconnecting cables and varying the mode of operation.

EUT and support equipment are on a 1 meter x 2.3 meter surface, 0.8 meter height wooden table. The vertical metal ground plane of 2.4 meter x 2.7 meter in size is placed 40 cm away from the rear of table top.

50 /50 μ H Line Impedance Stabilization Network (LISN) are 80cm away from the Host PC and placed on the conducting ground plane. LISN for peripheral is terminated in 50 .

Sufficient time for the EUT, support equipment and test equipment are allowed in order for them to warm up to their normal operating condition.

Test Configuration for Conducted emission Test

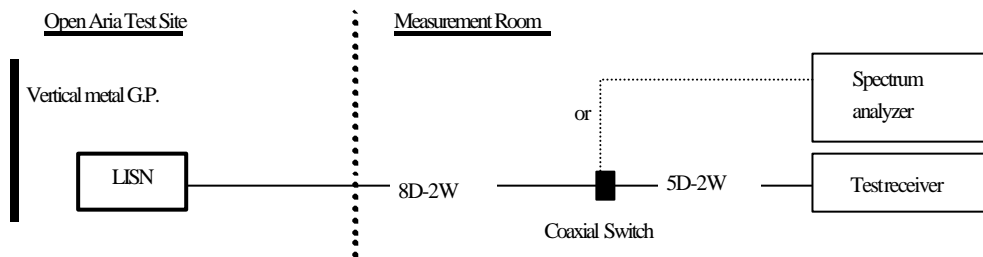

3.2 Test equipment for Conducted emission

Equipment	Company	Model No.	Serial No.	Calibration date	Period
Spectrum analyzer	Agilent Technologies	8568B	2517A01302	Aug. 2002	1 year
Test Receiver	Kyoritsu Electrical Works, Ltd.	KNM-2402	4N-192-1	Nov. 2001	1 year
Line Impedance Stabilization Network for Host PC	Kyoritsu Electrical Works, Ltd.	KNW-407	8-693-19	Dec. 2001	1 year
Line Impedance Stabilization Network for Peripheral	Kyoritsu Electrical Works, Ltd.	KNW-242C	8-1096-3	Apr. 2002	1 year
50 terminator	Agilent Technologies	11593A	N/A	Sep. 2002	1 year
Coaxial cable	FUJIKURA	8D-2W/15m 5D-2W/1m	YTCRFC#1C	May. 2002	1 year
Coaxial Switch	ANRITSU	MP59B	6100097273	May. 2002	1 year

* The calibrations of the above equipment are traceable to NIST or equivalent standards of the reference organizations.

3.3 Description of Radiated emission testing

Radiated emission measurements are performed at 3m distance with the broadband antenna (Biconical antenna, log-periodic antenna and double-ridged guide antenna). The antenna is positioned both the horizontal and vertical planes of polarization and height is varied 1 to 4 meters and stopped at height producing the maximum emission. Frequency Range: 30MHz - 1GHz is scanned and investigated with the test receiver, and above 1GHz, with the spectrum analyzer. The detector function of the test receiver is set to CISPR Quasi-peak mode and the bandwidth is set to 120kHz. Peak and average detectors are used for measurements above 1GHz. The bandwidth of the spectrum analyzer is set to 1MHz.

The EUT and support equipment are placed on a 1 meter x 2.3 meter surface, 0.8 meter height wooden table. The turntable is rotated by 360 degrees and stopped at azimuth of producing the maximum emission.

Interconnecting cables, which hanging closer than 40cm to the horizontal metal ground plane are bundled its excess in center. The highest frequency used in the EUT is 380MHz, therefore, the frequency range is investigated from 30MHz up to the frequency 2GHz, as specified in CFR section 15.33, and at least six highest emissions are reported. The test results represent the worst-case emission for each emission with manipulating the EUT, support equipment, interconnecting cables and varying the mode of operation.

Sufficient time for the EUT, support equipment, and test equipment are allowed in order for them to warm up to their normal operating condition.

Test Configuration for Radiated emission Test

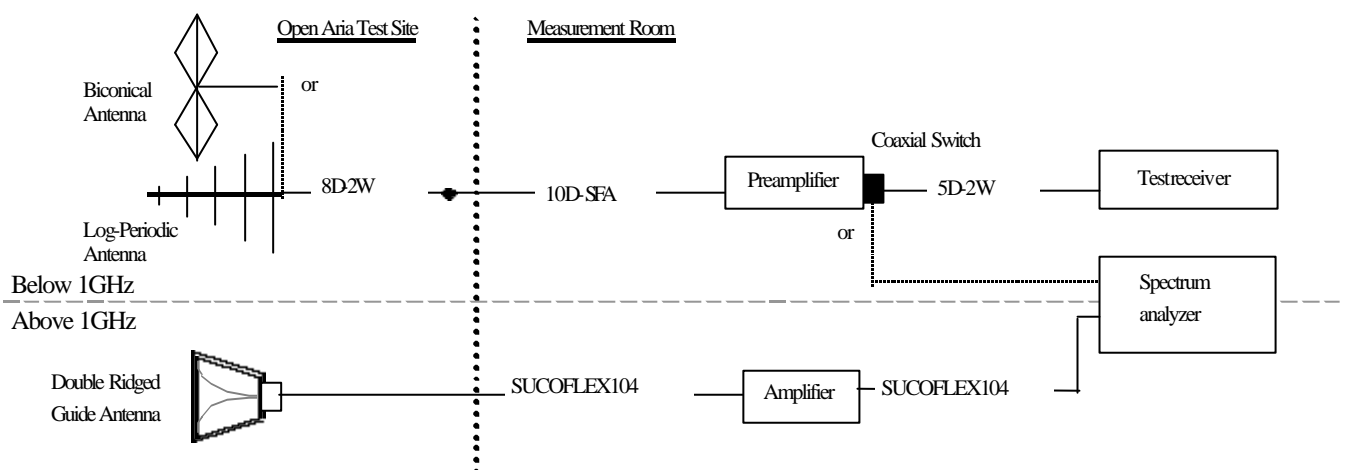

3.4 Test equipment for Radiated emission

[Testing below 1GHz]

Equipment	Company	Model No.	Serial No.	Calibration date	Period
Spectrum analyzer	Agilent Technologies	8568B	2517A01302	Aug. 2002	1 year
Preamplifier	Anritsu	MH648A	M96057	Oct. 2001	1 year
Test Receiver	Kyoritsu Electrical Works, Ltd.	KNM-5002 KCV-6002	4N-187-10 4-257-1	Dec. 2001	1 year
Biconical Antenna	Schwarzbeck	VHA9103/BBA9106	1635	May. 2002	1 year
Log Periodic Antenna	Schwarzbeck	UHALP9108A	0436	May. 2002	1 year
Coaxial cable	FUJIKURA	8D-2W/8m 10D-SFA/29m 5D-2W/1m	YTCRFC#1R	May. 2002	1 year
Coaxial Switch	ANRITSU	MP59B	6100097273	May. 2002	1 year
Site attenuation	ZACTA Technology Corp.	Site 1	N/A	Nov. 2001	1 year

[Testing above 1GHz]

Equipment	Company	Model No.	Serial No.	Calibration date	Period
Spectrum Analyzer	ADVANTEST	R3271A	65050042	Jun. 2002	1 year
Preamplifier	Agilent Technologies	HP8449B	3008A00589	Mar. 2002	1 year
Double Ridged Guide Antenna	EMCO	3115	4327	Sep. 2001	1 year
Coaxial cable	SUHNER	SUCOFLEX 104/15m SUCOFLEX 104/1m	108014/4 108015/4	Aug 2002	1 year

* The calibrations of the above equipment are traceable to NIST or equivalent standards of the reference organizations.

4. Laboratory description

4.1 Description for Test Site

1. Location: ZACTA Technology Corporation Yonezawa Testing Center
4149-7 Hachimanpara 5-chome Yonezawa-shi Yamagata 992-1128 Japan
Phone: +81-238-28-2880 Fax: +81-238-28-2888

2. The Number and Type of Site:

Site name: Site 1, Site 2 and Site 3 - Total 3 sites.
Site type : Whether protected site
*3m/10m Radiated emission & Conducted emission testing can be performed on each site

3. Facility filing information:

1) FCC site filing: Pursuant to CFR47 § 2.948

Site name	Final filing date (Terms of validity: 3 years)
Site 1, Site 2 and Site 3	March 6, 2000

2) Industry Canada Oats site filing: Pursuant to RSS 212, Issue 1(Provisional)

Site name	Sites on file: Oats 3m/10m	Filing date (Terms of validity: 3 ye ars)
Site 1	4224-1	January 31, 2002
Site 2	4224-2	January 31, 2002
Site 3	4224-3	January 31, 2002

3) VCCI site filing: Pursuant to V-5/99.05 VCCI Regulations for Registration of measurement facilities

Site name	Radiated emission Registration No.	Condu cted emission Registration No.	Duration of Registration
Site 1	R-136	C-132	September 30, 2003
Site 2	R-137	C-133	September 30, 2003
Site 3	R-138	C-134	September 30, 2003

4) NVLAP Accreditation:

NVLAP Lab. code: 200306-0

NVLAP information: NVLAP accreditation does not constitute any product endorsement by NVLAP or any agent of the U.S. Government

Scope of accreditation

Emission test methods: CISPR22, FCC Part 15-Digital Devices (Conducted / Radiated emission), AS/NZS3548.

Immunity test methods: IEC61000-4-2, 4-3, 4-4, 4-5, 4-6, 4-8, 4-11

4.2 Uncertainty

Expanded Uncertainties stated were calculated with a coverage Factor $k=2$.

$\pm 2.97\text{dB}$... For Conducted Emission
$\pm 5.23\text{dB}$... For 3m Radiated Emission
$\pm 4.26\text{dB}$... For 10m Radiated Emission

Judgment of Uncertainty under the measurement data and the scope of permission

Example A	Example B	Example C	Example D
Judgment: Complied	Judgment: Complied	Judgment: Not complied	Judgment: Not complied
The result of measurement is compliance with the limit in 95% or more confidence probability.	The result of measurement is compliance with the limit with less extent of uncertainty of the measurement. It is impossible to consider it complies with the limit in 95% confidence probability, but the result satisfies the limit in high probability.	The result of measurement is not compliance with the limit with less extent of uncertainty of the measurement. It is impossible to consider it complies with the limit in 95% confidence probability, but the result does not satisfy the limit in high probability.	The result of measurement is not compliance with the limit.

————— : Limit ■ : Result of the measurements - - - - - : Uncertainty

5. Results of the measurements

5.1 Results of the measurements

The minimum margins to the limits are as follows.

Conducted emission	Margin	Frequency	Detector	Phase	Operating mode	Data sheet
	9.3dB	1.469MHz	Quasi-peak	L2	CD Read mode	No. 1

Radiated emission	Margin	Frequency	Antenna Polarity	Antenna Height	Table degree	Operating mode	Data sheet
	8.3dB	237.07MHz	Vertical	1.0m	100°	DVD Read mode	No. 7

5.2 Deviation from the standard

Not applicable.

5.3 Sample of field strength calculation

Conducted Emission [Sample Calculation] $\text{dBuV} = 20\log_{10}(\text{uV})$

Class B
Limit @3.332MHz = 250uV = 48.0dBuV
Reading = 41.6dBuV Cable Loss + LISN Factor = 0.2 + 0.5 = 0.7dB Total = 41.6 + 0.7 = 42.3dBuV
Margin = 48.0 - 42.3 = <u>5.7dB</u>

Radiated Emission [Sample Calculation] $\text{dBuV/m} = 20\log_{10}(\text{uV/m})$

Class B
Limit @147.6MHz = 150uV/m = 43.5dBuV/m
Reading = 42.8dBuV Ant. Factor + Cable Loss - Amp. Gain = 14.2 + 3.0 - 30.0 = -12.8dB Total = 42.8 - 12.8 = 30.0dBuV/m
Margin = 43.5 - 30.0 = <u>13.5dB</u>

6. Test Data

***** CONDUCTED EMISSION *****

Standard : FCC Part15 SubpartB
Class : B

Sheet Number : 1

Date of test : 2002/9/20
Test Site : 1
Temperature [°C] : 27.6
Humidity [%] : 39.2
Operator : H.Saito
Company Name : SANYO
EUT : DVD-R Drive
Model Number : CRD-DV1
Serial Number : DV1PP2085
Test Mode : CD Read
Comment :

Signature : H. Saito

Phase	Frequency [MHz]	Reading		Factor [dB]	Emission Level		Limit		Margin		Comment
		QP [dB μ V]	AV [dB μ V]		QP [dB μ V]	AV [dB μ V]	QP [dB μ V]	AV [dB μ V]	QP [dB]	AV [dB]	
L1	1.270	38.3		0.1	38.4		48.0		9.6		
L1	1.469	36.2		0.1	36.3		48.0		11.7		
L1	2.070	36.0		0.2	36.2		48.0		11.8		
L1	2.339	35.3		0.2	35.5		48.0		12.5		
L1	2.607	33.0		0.2	33.2		48.0		14.8		
L1	12.800	35.4		0.6	36.0		48.0		12.0		
L2	1.269	38.0		0.1	38.1		48.0		9.9		
L2	1.469	38.6		0.1	38.7		48.0		9.3	*	
L2	2.070	35.6		0.2	35.8		48.0		12.2		
L2	2.339	35.7		0.2	35.9		48.0		12.1		
L2	2.539	35.9		0.2	36.1		48.0		11.9		
L2	12.800	36.3		0.6	36.9		48.0		11.1		

* : The worst emission.

Factor : LISN Factor + Cable Loss

Ver.2.40 F1#008

***** CONDUCTED EMISSION *****

Standard : FCC Part15 SubpartB
Class : B

Sheet Number : 2

Date of test : 2002/9/20
Test Site : 1
Temperature [℃] : 27.6
Humidity [%] : 39.2
Operator : H.Saito
Company Name : SANYO
EUT : DVD-R Drive
Model Number : CRD-DV1
Serial Number : DV1PP2085
Test Mode : CD Write
Comment :

Signature : H. Saito

Phase	Frequency [MHz]	Reading		Factor [dB]	Emission Level		Limit		Margin		Comment
		QP [dB μ V]	AV [dB μ V]		QP [dB μ V]	AV [dB μ V]	QP [dB μ V]	AV [dB μ V]	QP [dB]	AV [dB]	
L1	1.269	38.1		0.1	38.2		48.0		9.8		
L1	1.469	36.2		0.1	36.3		48.0		11.7		
L1	2.071	35.4		0.2	35.6		48.0		12.4		
L1	2.338	35.4		0.2	35.6		48.0		12.4		
L1	2.604	33.7		0.2	33.9		48.0		14.1		
L1	12.800	34.7		0.6	35.3		48.0		12.7		
L2	1.269	37.7		0.1	37.8		48.0		10.2		
L2	1.468	38.3		0.1	38.4		48.0		9.6		*
L2	2.070	35.6		0.2	35.8		48.0		12.2		
L2	2.337	35.3		0.2	35.5		48.0		12.5		
L2	2.538	35.8		0.2	36.0		48.0		12.0		
L2	12.800	33.8		0.6	34.4		48.0		13.6		

*: The worst emission. Factor: LISN Factor + Cable Loss Ver.2.40 F1#008

***** CONDUCTED EMISSION *****

Standard : FCC Part15 SubpartB
Class : B

Sheet Number : 3

Date of test : 2002/9/20
Test Site : 1
Temperature [℃] : 27.6
Humidity [%] : 39.2
Operator : H.Saito
Company Name : SANYO
EUT : DVD-R Drive
Model Number : CRD-DV1
Serial Number : DV1PP2085
Test Mode : DVD Read
Comment :

Signature : H. Saito

Phase	Frequency [MHz]	Reading		Factor [dB]	Emission Level		Limit		Margin		Comment
		QP [dB μ V]	AV [dB μ V]		QP [dB μ V]	AV [dB μ V]	QP [dB μ V]	AV [dB μ V]	QP [dB]	AV [dB]	
L1	1.270	38.2		0.1	38.3		48.0		9.7		
L1	1.470	36.0		0.1	36.1		48.0		11.9		
L1	2.070	35.8		0.2	36.0		48.0		12.0		
L1	2.338	35.1		0.2	35.3		48.0		12.7		
L1	2.607	32.9		0.2	33.1		48.0		14.9		
L1	12.800	34.6		0.6	35.2		48.0		12.8		
L2	1.269	37.9		0.1	38.0		48.0		10.0		
L2	1.470	38.3		0.1	38.4		48.0		9.6		*
L2	2.069	35.4		0.2	35.6		48.0		12.4		
L2	2.338	35.3		0.2	35.5		48.0		12.5		
L2	2.539	35.2		0.2	35.4		48.0		12.6		
L2	12.800	35.4		0.6	36.0		48.0		12.0		

*: The worst emission.

Factor: LISN Factor + Cable Loss

Ver.2.40 F1#008

***** CONDUCTED EMISSION *****

Standard : FCC Part15 SubpartB
Class : B

Sheet Number : 4

Date of test : 2002/9/20
Test Site : 1
Temperature [℃] : 27.6
Humidity [%] : 39.2
Operator : H.Saito
Company Name : SANYO
EUT : DVD-R Drive
Model Number : CRD-DV1
Serial Number : DV1PP2085
Test Mode : DVD Write
Comment :

Signature : H. Saito

Phase	Frequency [MHz]	Reading		Factor	Emission Level		Limit		Margin		Comment
		QP [dB μ V]	AV [dB μ V]		QP [dB μ V]	AV [dB μ V]	QP [dB μ V]	AV [dB μ V]	QP [dB]	AV [dB]	
L1	1.270	38.0		0.1	38.1		48.0		9.9		
L1	1.469	35.9		0.1	36.0		48.0		12.0		
L1	2.070	35.9		0.2	36.1		48.0		11.9		
L1	2.339	35.3		0.2	35.5		48.0		12.5		
L1	2.607	33.1		0.2	33.3		48.0		14.7		
L1	12.800	35.1		0.6	35.7		48.0		12.3		
L2	1.269	38.1		0.1	38.2		48.0		9.8		*
L2	1.469	37.8		0.1	37.9		48.0		10.1		
L2	2.070	35.2		0.2	35.4		48.0		12.6		
L2	2.339	35.0		0.2	35.2		48.0		12.8		
L2	2.539	34.9		0.2	35.1		48.0		12.9		
L2	12.800	35.3		0.6	35.9		48.0		12.1		

* : The worst emission.

Factor: LISN Factor + Cable Loss

Ver.2.40 F1#008

***** RADIATED EMISSION *****

Standard : FCC Part15 SubpartB
 Class : B
 Distance [m] : 3
 Date of test : 2002/9/20
 Test Site : 1
 Temperature [℃] : 25.8
 Humidity [%] : 43.1
 Operator : H.Saito
 Company Name : SANYO
 EUT : DVD-R Drive
 Model Number : CRD-DV1
 Serial Number : DV1PP2085
 Test Mode : CD Read
 Comment :

Sheet Number : 5

Signature : H. Saito

Antenna Pol.	Antenna Height [m]	Table Radian [Deg.]	Reading Frequency [MHz]	Reading Level [dB μV]	Factor [dB/m]	Emission Level [dB μV/m]	Limit [dB μV/m]	Margin [dB]	Comment
HOR/VER	4.0	120	58.22	45.0	-19.8	25.2	40.0	14.8	
VER	1.0	75	220.12	48.2	-11.4	36.8	46.0	9.2	*
VER	1.0	95	237.07	46.0	-11.2	34.8	46.0	11.2	
VER	1.0	45	253.99	45.7	-11.0	34.7	46.0	11.3	
HOR	2.5	130	321.76	44.8	-12.8	32.0	46.0	14.0	
VER	2.6	40	321.76	44.4	-12.8	31.6	46.0	14.4	
HOR	1.2	35	465.87	43.5	-10.3	33.2	46.0	12.8	
VER	1.0	160	660.23	37.6	-6.5	31.1	46.0	14.9	
HOR	2.2	265	660.29	41.3	-6.5	34.8	46.0	11.2	

* : The worst emission.

Factor: Antenna Factor + Cable Loss - Amp Gain

Ver.2.40 F1#008

***** RADIATED EMISSION *****

Standard : FCC Part15 SubpartB
 Class : B
 Distance [m] : 3
 Date of test : 2002/9/20
 Test Site : 1
 Temperature [℃] : 25.8
 Humidity [%] : 43.1
 Operator : H.Saito
 Company Name : SANYO
 EUT : DVD-R Drive
 Model Number : CRD-DV1
 Serial Number : DV1PP2085
 Test Mode : CD Write
 Comment :

Sheet Number : 6

Signature : H. Saito

Antenna Pol.	Antenna Height [m]	Table Radian [Deg.]	Reading Frequency [MHz]	Reading Level [dB μ V]	Factor [dB/m]	Emission Level [dB μ V/m]	Limit [dB μ V/m]	Margin [dB]	Comment
HOR	4.0	315	58.22	45.7	-19.8	25.9	40.0	14.1	
VER	1.0	300	146.50	40.1	-13.5	26.6	43.5	16.9	
VER	1.0	45	250.83	38.8	-11.0	27.8	46.0	18.2	
HOR	1.0	130	432.07	40.3	-10.9	29.4	46.0	16.6	
HOR	1.0	295	465.87	43.4	-10.3	33.1	46.0	12.9	*
VER	1.3	185	465.87	39.0	-10.3	28.7	46.0	17.3	
VER	1.9	310	650.09	33.0	-6.7	26.3	46.0	19.7	
VER	1.8	170	998.40	33.7	-1.6	32.1	54.0	21.9	

* : The worst emission.

Factor: Antenna Factor + Cable Loss - Amp Gain

Ver.2.40 F1#008

***** RADIATED EMISSION *****

Standard : FCC Part15 SubpartB
 Class : B
 Distance [m] : 3
 Date of test : 2002/9/20
 Test Site : 1
 Temperature [c] : 25.8
 Humidity [%] : 43.1
 Operator : H.Saito
 Company Name : SANYO
 EUT : DVD-R Drive
 Model Number : CRD-DV1
 Serial Number : DV1PP2085
 Test Mode : DVD Read
 Comment :

Sheet Number : 7

Signature : H. Saito

Antenna Pol.	Height [m]	Table Radian [Deg.]	Reading		Factor [dB/m]	Emission Level [dB μ V/m]	Limit [dB μ V/m]	Margin [dB]	Comment
			Frequency [MHz]	Level [dB μ V]					
HOR	4.0	115	58.22	44.3	-19.8	24.5	40.0	15.5	
VER	1.0	75	220.12	48.8	-11.4	37.4	46.0	8.6	
VER	1.0	100	237.07	48.9	-11.2	37.7	46.0	8.3	*
VER	1.0	50	253.99	46.3	-11.0	35.3	46.0	10.7	
HOR	1.0	336	321.76	46.2	-12.8	33.4	46.0	12.6	
VER	1.0	200	321.76	45.4	-12.8	32.6	46.0	13.4	
HOR	1.0	200	423.33	43.2	-11.1	32.1	46.0	13.9	
HOR	1.0	295	432.09	41.9	-10.9	31.0	46.0	15.0	
HOR	1.0	0	465.87	44.9	-10.3	34.6	46.0	11.4	

*: The worst emission.

Factor: Antenna Factor + Cable Loss - Amp Gain

Ver 2.40 F1#008

***** RADIATED EMISSION *****

Standard : FCC Part15 SubpartB
 Class : B
 Distance [m] : 3
 Date of test : 2002/9/20
 Test Site : 1
 Temperature [°C] : 25.8
 Humidity [%] : 43.1
 Operator : H.Saito
 Company Name : SANYO
 EUT : DVD-R Drive
 Model Number : CRD-DV1
 Serial Number : DV1PP2085
 Test Mode : DVD Write
 Comment :

Sheet Number : 8

Signature : H. Saito

Antenna Pol.	Height [m]	Table Radian [Deg.]	Reading		Factor [dB/m]	Emission Level [dB μ V/m]	Limit [dB μ V/m]	Margin [dB]	Comment
			Frequency [MHz]	Level [dB μ V]					
HOR	4.0	120	58.10	44.8	-19.8	25.0	40.0	15.0	
VER	1.0	300	146.50	40.2	-13.5	26.7	43.5	16.8	
VER	1.0	70	197.17	37.9	-11.5	26.4	43.5	17.1	
HOR	1.1	50	419.78	40.0	-11.2	28.8	46.0	17.2	
HOR	1.0	130	432.07	40.6	-10.9	29.7	46.0	16.3	
HOR	1.0	30	465.87	43.7	-10.3	33.4	46.0	12.6	*
VER	1.3	185	465.87	35.3	-10.3	25.0	46.0	21.0	
VER	1.8	165	998.40	33.8	-1.6	32.2	54.0	21.8	

*: The worst emission.

Factor: Antenna Factor + Cable Loss - Amp Gain

Ver.2.40 F1#008