



[QUICK START]

Follow the directions on these two pages to start using your phone right away. For more information, refer to the rest of this user guide.

... To turn on your phone

You must turn on your phone in order to use any of its features.

- Press  for about a second, until the  icon appears on the display.

... To make a call

- Dial the number on the keypad, then press .

... To hang up

- Press .

... To answer a call

- When the phone rings, press  to answer it.





... To save a number in the phone book

1. Enter the number you want to save. The *[MENU]* Smart Key changes to *[SAVE]*. See page 6 for more on Smart Keys.
2. Press the  key under *[SAVE]*.
3. Follow the directions on the screen. See "Saving a number" on page 19 for more information.

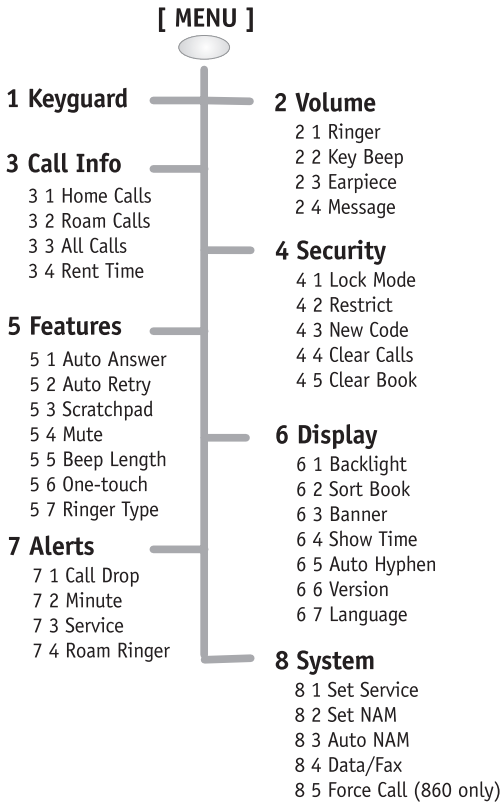
... To speed dial a phone number

1. Enter a memory location from the phone book.
2. Press .



- Press the  key under [MENU] to enter the menu structure.
- Press  or  to scroll up or down through the menus.
- Enter the menu and menu item number (such as **6 3** for Display > Banner) to open a menu item.
- Press  to back up one level without saving changes, or  to cancel all the way out of the menus.

[QCP-860™ and QCP-1960™] USER GUIDE

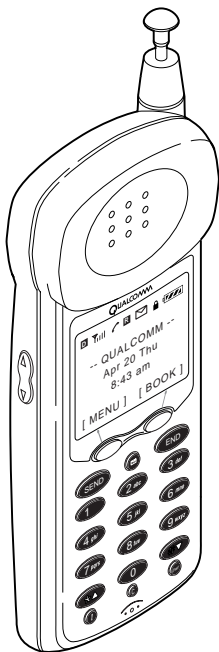

S029_56A1



QUALCOMM Incorporated
6455 Lusk Boulevard, San Diego, California 92121-2779 U.S.A.
<http://www.qualcomm.com/cdma>
80-68790-2EN_Rev -

This manual is based on the production version of the QCP-860 and QCP-1960 telephones. Software changes may have occurred after this printing. QUALCOMM reserves the right to make changes in technical and product specifications without prior notice. The products and equipment described in this documentation are manufactured under one or more of the following U.S. Patents:

4,901,307, 5,056,109, 5,099,204, 5,101,501, 5,103,459,
5,107,225, 5,109,390, 5,193,094, 5,228,054, 5,257,283,
5,265,119, 5,267,261, 5,267,262, 5,280,472, 5,283,536,
5,289,527, 5,207,405, 5,309,474, 5,337,338, 5,339,046,
5,341,456, 5,383,219, 5,392,287, 5,396,516, D356,560,
5,408,697, 5,414,728, 5,414,796, 5,416,797, 5,426,392,
5,437,055, D361,065, 5,442,322, 5,442,627, 5,452,473,
5,461,639, 5,469,115, 5,469,471, 5,471,497, 5,475,870,
5,479,475, 5,483,696, 5,485,486, 4,487,175, 5,490,165,
5,497,395, 5,499,280, 5,504,773, 5,506,865, 5,509,015,
5,509,035, 5,511,067, 5,511,073, 5,513,176, 5,515,177,
5,517,323, 5,519,761, 5,528,593, 5,530,928, 5,533,011,
5,535,239, 5,539,531, 5,544,196, 5,544,223, 5,546,459,
5,548,812, 5,559,881, 5,559,865, 5,561,618, 5,564,083,
5,566,000, 5,566,206, 5,566,357, 5,568,483, 5,574,773,
5,574,987, D375,740, 5,576,662, 5,577,022, 5,577,265,
D375,937, 5,588,043, D376,804, 5,589,756, 5,590,069,
5,590,406, 5,590,408, 5,592,548, 5,594,718, 5,596,570,
5,600,754, 5,602,834, 5,602,833, 5,603,096, 5,604,730,
5,604,459, 5,604,730, 5,608,722, 5,614,806, 5,617,060,
5,621,752, 5,621,784, 5,621,853, 5,625,876, 5,627,857,
5,629,955, 5,629,975, 5,638,412, 5,640,414, 5,642,398,
5,644,591, 5,644,597, 5,646,991, 5,652,814, 5,656,979,
5,655,229, 5,657,420, 5,659,569, 5,663,807. Other patents
pending.

FCC/IC Notice

This device complies with part 15 of the FCC rules. Operation is subject to the following two conditions: (1) This device may not cause harmful interference, and (2) this device must accept any interference received, including interference that may cause undesired operation.

Copyright © 1998 QUALCOMM Incorporated. All rights reserved.
Printed in the United States of America.

QUALCOMM is a registered trademark and registered service mark of QUALCOMM Incorporated. Data on the Go is a registered trademark and Smart Keys, QCP-860, and QCP-1960 are trademarks of QUALCOMM Incorporated.

[Customer Support]

Your service provider's customer support department should be able to answer all your questions. You may also call U.S. 619-651-4028 or 800-349-4478 (toll-free, U.S. only) for QUALCOMM Customer Service.

Consult QUALCOMM's web site at www.qualcomm.com for more information about all our phones.

Visit the Cellular Telecommunications Industry Association (CTIA) website at www.wow-com.com (wow-com™) or call 888-901-SAFE (toll-free, U.S. only) for telecommunications industry standards and driving safety information.

[Accessories]

Accessories make your QUALCOMM phone even more powerful and easy to use. You can purchase a hands-free car kit, hands-free headset, leather case, desktop charger, external battery, and more. To obtain QUALCOMM accessories, visit the place where you bought your phone or an authorized QUALCOMM service center. You can also call 800-349-4188 (toll-free, U.S. only) or visit our website at www.qualcomm.com.

[TABLE OF CONTENTS]

Quick start	i
Getting to know your phone	1
Turning the phone on and off	1
Safe operating instructions	2
Understanding the display	3
Smart Keys	5
Standby mode	5
Using the keys	6
Using the keyguard	8
Charging the batteries	9
Making and receiving calls	10
Making and receiving calls	10
Redialing calls	11
Recent history list	12
Service provider calling features	13
Caller ID	13
Three-way calling	13
Call forwarding	14
Call waiting	14
Adjusting the volume	15
Phone book	16
Saving a number	17
Saving a name with the number	19
Special characters	21
Entering pauses and hyphens	22
Example	23
Dialing from the phone book	24
Touch dialing	24
Changing the phone book	26
Erasing secret numbers	27

Searching the phone book	28
Example	29
Voice mail, pages, and text messages	30
Types of messages	30
Alerts.	31
Memory	31
Voice mail	32
Pages and text messages	33
Menus	34
Diagram	34
Menu item descriptions	36
Caring for your phone	45
Phone	45
Antenna	46
Battery.	47
Resetting the phone	48
External batteries	49
Battery power levels	51
Hot swapping	51
Charging accessories	53
Power save mode	56
Safety information	57
Radio Frequency (RF) energy	57
Exposure to RF energy	57
Medical devices	58
Potentially unsafe areas	59
Emergency numbers	60
Driving safely	61
Air bags	63
Index	64

Tip. If you can't find what you are looking for in the Table of Contents, look in the Index.

[GETTING TO KNOW YOUR PHONE]

Turning the phone on and off

... To turn the phone on

1. Fully extend the antenna for optimal reception.
2. Hold down  for about a second.

“Searching...” means the phone is searching for a signal.

 means the phone has found a signal. You can make and receive calls.

“Roaming” means you are outside your home system.

 means the phone cannot find a signal. Wait a little longer or move into an open area.

Once your phone is on, it enters standby mode, which is the phone's idle state. See page 5 for more information.

... To view your own phone number



- From standby mode, press . *Your phone number appears on the display.*

... To turn the phone off

- Hold down  until “Powering off” appears on the display.

Safe operating instructions

Using your phone properly increases the number of years of service it will give you. Read the following cautions before you use the phone.

- **If you have a pacemaker, keep the phone at least six inches (15 centimeters) away from your chest.** If your phone is too close to a pacemaker, its radio frequency (RF) energy may interfere with the pacemaker. If you have any reason to suspect a problem, turn off your phone immediately. See “Safety information” on page 57 for more information.
- **If you plan to carry your phone in a pocket or purse, activate the keyguard to prevent accidental key presses.** Press the  key under the word [MENU] on the display, then press  to activate the keyguard. See “Using the keyguard” on page 8 for more information.
- **Only use QUALCOMM-approved accessories with QUALCOMM phones.** Use of any unauthorized accessories may be dangerous and will invalidate the phone warranty if said accessories cause damage or a defect to the phone.

NAVIGATION TIPS



DIAL or ANSWER



HANG UP or EXIT MENUS



OWN NUMBER or CALL INFO



ERASE or BACK OUT OF MENU

Understanding the display

Your phone has a five-line display. The top line contains the display icons defined in the following list. The two words on the bottom line define the current function of the Smart Keys™ (described on page 5).

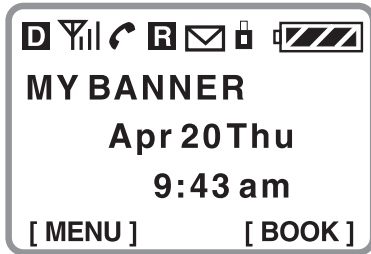

Digital Mode icon. The phone is operating in CDMA digital mode. Digital CDMA calls have advantages such as privacy, voice clarity, and longer battery life. If you have service but the digital mode icon is not visible, you are in analog mode.



Signal Strength icon. The more bars you see, the stronger the incoming signal. A weak signal may cause an intermittent connection. Fully extend the antenna or, if you are in a building, try standing by a window.



No Signal icon. You can't make or receive any calls, because your phone is not

NAVIGATION TIPS



MOVE LEFT or SCROLL UP



[MENU] ENTER MENU STRUCTURE



MOVE RIGHT or SCROLL DOWN



[BOOK] VIEW PHONE BOOK

receiving any signal. Wait a few minutes to see if you get a signal, or try moving into an open area.



On Call icon. Indicates you are on a call.



Roaming icon. You are outside of your regular service area. If the icon is flashing, it means that you are completely outside your home system. Different rates may apply.



Envelope icon. You have a voice mail, page, or text message. Press  to see message information. See “Voice mail, pages, and text messages” on page 30.



Padlock icon. Your phone is operating with enhanced CDMA voice privacy. Your service provider determines the availability of this feature. When the padlock icon appears over a Smart Key, the keyguard is on.



Battery Charge icon. This icon indicates how much power is left in the battery that is currently in use. The more black bars you see, the fuller the battery is. See “Battery power levels” on page 51 for information about recharging the battery.

N A V I G A T I O N T I P S



DIAL or ANSWER



HANG UP or EXIT MENUS



OWN NUMBER or CALL INFO





ERASE or BACK OUT OF MENU



Smart Keys

Smart Keys  are the two unlabeled keys immediately beneath the display. You can see them on the phone picture, next page (# 2). They change function depending on the situation. The word immediately above each Smart Key on the display identifies its current function. In standby mode, the Smart Keys are [MENU] and [BOOK].

When the directions in this manual tell you to press a Smart Key, they always start with either the [MENU] or [BOOK] Smart Key. Once you press either key, the Smart Keys change to something else.

Standby mode

When the phone is turned on and idle for more than a minute, it returns to standby mode. From standby mode, you can press the  key under [MENU] to open the menus or the  key under [BOOK] to view the phone book. If you enter a phone number, you can press  to dial it, follow the instructions on the display to save it in the phone book, or find it in the phone book if it is already there.

Press  at any time to return to standby mode. Be careful; if you are on a call when you press the End key, you'll return to standby mode but you will also end the call. Press  several times or hold it down to return to standby mode without ending the call.

NAVIGATION TIPS



MOVE LEFT or SCROLL UP



[MENU] ENTER MENU STRUCTURE



MOVE RIGHT or SCROLL DOWN



[BOOK] VIEW PHONE BOOK

Using the keys

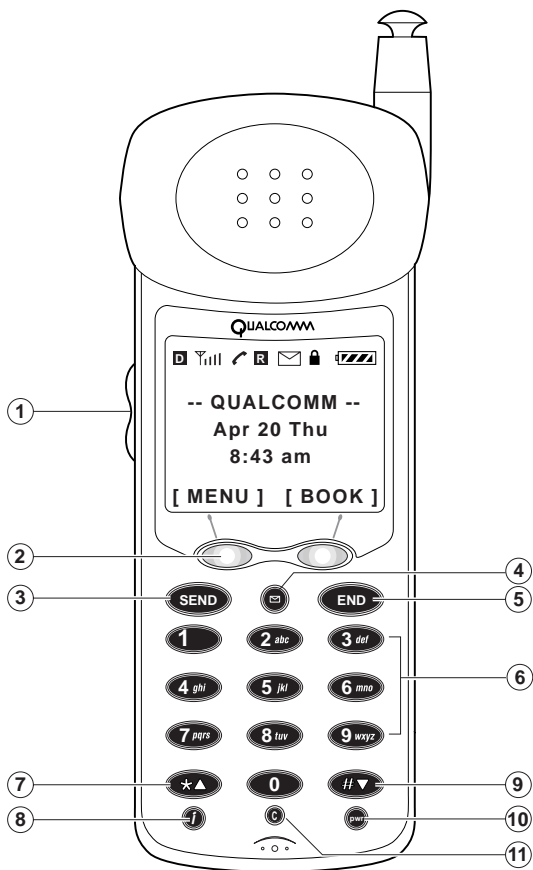

1.



Press the volume keys on the side of the phone to adjust the volume, move the cursor when editing numbers, and scroll through menus.

NAVIGATION TIPS



DIAL or ANSWER











HANG UP or EXIT MENUS



OWN NUMBER or CALL INFO



ERASE or BACK OUT OF MENU

2.  The two Smart Keys change function depending on what screen you are in. Look at the word on the display above the key for the current function.
3.  Press the Send key to make or answer a call.
4.  When the Envelope icon appears on the display, press the Message key to open the message screen.
5.  Press the End key to end a call or to silence the ringer when it rings. Press the End key at any time to cancel out of the current screen and return to standby mode.
6.  ... Use the keypad to enter digits, letters, and punctuation characters, or to select menu options. Press any number to answer a call.
7.  Press the Star (up arrow) key to answer a call, scroll up through menus and displays, or move the cursor leftward when editing.
8.  Press the Information key from standby mode to see your own phone number. When you are viewing a recent call record, press it to see extra information about the call.
9.  Press the Pound (down arrow) key to answer a call, scroll down, or move the cursor rightward when editing.

 NAVIGATION TIPS

MOVE LEFT or SCROLL UP





[MENU] ENTER MENU STRUCTURE





MOVE RIGHT or SCROLL DOWN



[BOOK] VIEW PHONE BOOK



10.  Press and hold the Power key down for about a second to turn the phone on or off.
11.  Press the Clear key once to erase the last character. Press and hold  to erase the whole line.

Press  once to back up to the previous menu level. Press and hold  to return to standby mode.



Using the keyguard

The keyguard protects your phone against accidental key presses when the phone is turned on. Press  to answer calls while the keyguard is on.

*** To turn on the keyguard

1. Press the  key under [MENU].
2. Press  to activate the keyguard. *The left Smart Key turns into the padlock icon .*

*** To turn off the keyguard

1. Press the  key under the  Smart Key.
2. Press .

See “Security” on page 38 to learn how to lock your phone with a security code or restrict the use of your phone.

NAVIGATION TIPS



DIAL or ANSWER



HANG UP or EXIT MENUS



OWN NUMBER or CALL INFO



ERASE or BACK OUT OF MENU

Charging the batteries

Your phone comes with a rechargeable internal lithium ion (LiIon) battery. You do not need to remove this battery for charging. The battery is partially charged when you receive the phone. If the battery level falls too low, the phone turns off without saving any functions in progress.

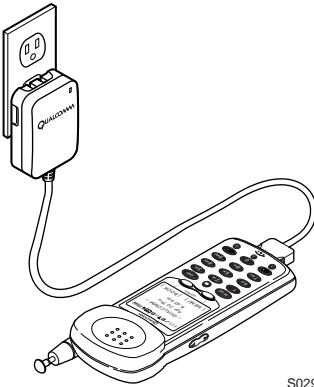

S029_65A

Your phone comes with either an AC Adaptor or a Global Travel Charger (Model # TXTVL031). Fully charge the battery as soon as you can to maximize talk time. LiIon batteries are extremely reliable

and provide exceptionally long talk and standby times.

See “Charging accessories” on page 53 to learn about the variety of charging accessories available for your phone.

You can purchase an optional external battery to extend the talk and standby times. If the external battery is attached to the phone, the charging accessory charges the internal battery first, then the external. See “External batteries” on page 49 for more information.

NAVIGATION TIPS



MOVE LEFT or SCROLL UP



[MENU] ENTER MENU STRUCTURE



MOVE RIGHT or SCROLL DOWN



[BOOK] VIEW PHONE BOOK

[MAKING AND RECEIVING CALLS]

This section explains how to make and receive calls. In addition to basic dialing and answering operations, you'll learn how to use advanced features like muting calls, redialing any of the last ten numbers, and setting up a three-way conversation.

Your phone must be turned on in order to use any of its features. When the phone is off, incoming calls go to voice mail if available (see "Voice mail, pages, and text messages" on page 30).

Making and receiving calls

... To make a call

1. Press the numbers on the keypad to dial a number. See "Phone book" on page 16 to learn how to save and speed dial your favorite numbers.
2. Press .

... To answer a call

3. When the phone rings, press  to answer.

... To end a call

- Press  to end a call.

Redialing calls



Your phone keeps a “recent history” list of the last ten incoming and outgoing calls. You can easily redial or save any number on the list.

... To redial the last number you dialed

➤ When you are in standby mode, press  until you see “CALLING...” on the display.

Tip. If you are not sure what mode you are in, press  to return to standby mode.

... To redial from the recent history list

1. Press the  key under [BOOK]. *The [BOOK] Smart Key changes to [CALLS].*
2. Press the  key under [CALLS]. *The recent history list appears and the [CALLS] Smart Key changes to [VIEW].*
3. Scroll through the list to the number you want.
4. Press  to dial the number

-or-

Press the  key under [VIEW] to see more information about the call or to save the number into the phone book.

NAVIGATION TIPS



MOVE LEFT or SCROLL UP



[MENU] ENTER MENU STRUCTURE



MOVE RIGHT or SCROLL DOWN



[BOOK] VIEW PHONE BOOK

Recent history list

The recent history list contains some or all of the following types of calls.

- Called By** Incoming calls, if caller ID is available.
- Call To** Any numbers you dialed.
- Missed** Unanswered incoming calls, if caller ID is available. This type does not include call attempts made when the phone was off.
- Call Waiting** Incoming calls that occurred while you were on another call. This type of call only occurs if your system supports call waiting.
- 3-Way Calling** The second party you dialed during a three-way call. This type of call only occurs if your system supports three-way calling.
- Added** Any numbers you added during a call using the scratchpad feature.

Duplicate calls appear once on the list. Calls are considered duplicates only if they contain the same number *and* have the same call type, such as Called By.

... To edit the recent history list

- While viewing a number in the recent history list, press a digit such as **1** to begin editing the number. Use ***▲** or **#▼** to move the cursor, then enter or delete numbers as you wish.

N A V I G A T I O N T I P S



DIAL or ANSWER



HANG UP or EXIT MENUS



OWN NUMBER or CALL INFO



ERASE or BACK OUT OF MENU

Service provider calling features

Your service provider may offer extra features like caller ID, three-way calling, call forwarding, and call waiting. If you wish to use these features, contact your service provider for details. Your QUALCOMM phone supports all of these options *if* they are activated on your phone.



Caller ID

Caller ID is a service provider feature that displays the number of the person that is calling you. If you have already saved that number in your phone book, the name on the phone book entry also appears.

Three-way calling

Three-way calling enables three parties to talk on the same phone conversation.

... To set up a three-way call



1. Dial the first party.
2. At this point, some service providers require you to press  to put the first party on hold.
3. Dial the second number (you may use touch or speed dialing) and press .
4. When the third party picks up, press  again to connect all three parties.

If one of you hangs up, the other two stay connected.

NAVIGATION TIPS



- | | | | |
|---|---------------------------|---|-----------------------------|
|  | MOVE LEFT or SCROLL UP |  | [MENU] ENTER MENU STRUCTURE |
|  | MOVE RIGHT or SCROLL DOWN |  | [BOOK] VIEW PHONE BOOK |

Call forwarding

Some service plans allow you to forward your calls to another number. Typically, you press  plus a numerical code, then enter the forwarding number and press . The phone beeps and shows a message confirming that you have forwarded your calls. Consult your service provider for details.

Call waiting

... To use call waiting

1. When you are on a call and another call comes in, you hear two beeps. *The display informs you that a call is coming in, and shows the caller's phone number if it is available.*
 2. Press  to switch to the incoming call. *The previous caller is put on hold.*
 3. Press  to toggle between the callers.
- If you press  to disconnect one call, you are still connected to the other call.

NAVIGATION TIPS



DIAL or ANSWER



HANG UP or EXIT MENUS



OWN NUMBER or CALL INFO





ERASE or BACK OUT OF MENU

Adjusting the volume

This section explains some easy ways to adjust the volume. You can also use the menu options on the Volume menu (see “Volume” on page 36).

... To silence the ringer

- When the phone rings, press  to turn off the ringer.

The display momentarily reads “RINGER SILENCED,” then returns to “INCOMING CALL.” You may press  to answer the call even after turning off the ringer.

... To mute a call

- During a call, hold the  key under [MENU] for about two seconds to mute or unmute the phone.

When the phone is muted, the message “MUTED” appears on the display. The other party will not hear anything you say.

... To adjust the earpiece volume

- During a call, press  or  to adjust the earpiece volume up or down.

... To adjust the ringer volume

- In standby mode, press the volume keys to adjust the ringer volume up or down.

NAVIGATION TIPS



MOVE LEFT or SCROLL UP



[MENU] ENTER MENU STRUCTURE



MOVE RIGHT or SCROLL DOWN



[BOOK] VIEW PHONE BOOK

[PHONE BOOK]

You can save phone numbers and associated information in your phone for quick dialing. There are 99 “memory locations” in the phone book. Each memory location holds up to 32 digits. You can also enter a name to go with the phone number. The name can be up to 12 characters.

••• To speed dial a phone number

➤ Enter the memory location number and press



See “Searching the phone book” on page 28 to learn different ways of finding numbers in the phone book.



Saving a number



Tip: When you save a number in the phone book, include long distance information. That way, you can dial the number from anywhere. If it's a local number, you only pay local rates.

... To save a number from standby mode

1. Enter the phone number you want to save. *The [MENU] Smart Key changes to [SAVE].*
2. Press the  key under [SAVE]. *The name screen appears.*

3. Enter a name to go with the number. To enter a letter, press the corresponding number key.

For instance, to enter the letter J, press  one time. To enter the letter K, press  again. If you miss the letter you want, keep pressing the key to cycle back to it. See "Saving a name with the number" on page 19 for more details.

4. Press the  key under [OK] to save the name. *The memory location screen appears.*
5. Press the  key under [OK] to assign the first available memory location number. *Later, you can speed dial the number by entering the memory location number and pressing .*



-or-

NAVIGATION TIPS

- | | | | |
|---|---------------------------|---|-----------------------------|
|  | MOVE LEFT or SCROLL UP |  | [MENU] ENTER MENU STRUCTURE |
|  | MOVE RIGHT or SCROLL DOWN |  | [BOOK] VIEW PHONE BOOK |

enter a two-digit number between 01 and 99. *If the number is already assigned, the phone asks if you wish to overwrite the previous entry.*

Press the  key under [OK] to save the memory location number. *The Make Secret? screen appears.*

6. Press the  key under [NEXT] to cycle through the options. Press the  key under [OK] when you see the option you want.
- **No** allows the phone number to appear normally in the phone book, recent history list, and so on.
 - **Yes** hides the phone number so no one can see it. The name remains visible. If you did not enter a name, "SECRET" appears in place of the name. You cannot view or edit a secret phone entry.

When you finish all the steps, a confirmation message appears to let you know that you have successfully saved your entry into the phone book.

N A V I G A T I O N T I P S



DIAL or ANSWER



HANG UP or EXIT MENUS







OWN NUMBER or CALL INFO







ERASE or BACK OUT OF MENU



Saving a name with the number

To enter letters, press the key labeled with the letter you want. For instance, if you press , the letter A appears on the display. Press  again to cycle through the remaining letters.

Two seconds after you choose a character, or when you enter another letter, the cursor moves to the right one space. You can also press  or  to move the cursor backward or forward.

Example. To enter the name "Ann," press  once to enter the capital letter "A." Press the  key under [A->a] to switch to lower case. Press  twice to enter a lower case "n." Move the cursor to the last space and press  twice again to enter the second "n."

... To switch between upper and lower case

1. The letters start out in upper case. Press the  key under [A->a] to change to lower case. *The [A->a] Smart Key changes to [a->A].*
2. Press the  key under [a->A] to return to upper case.

NAVIGATION TIPS



MOVE LEFT or SCROLL UP



[MENU] ENTER MENU STRUCTURE



MOVE RIGHT or SCROLL DOWN





[BOOK] VIEW PHONE BOOK

*** To enter punctuation characters

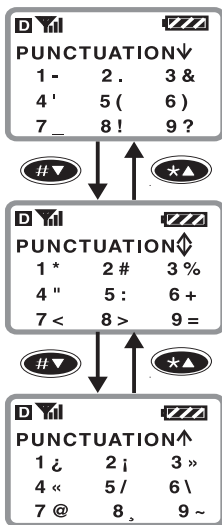
1. While entering a name, press  to open a list of 27 punctuation characters (shown below). Each character is associated with a number key.



2. Use  or  to move up or down between the three screens of characters.
3. To enter a punctuation mark, press the number associated with it. To cancel out of the screen without entering a punctuation mark, press .

NAVIGATION TIPS



DIAL or ANSWER



HANG UP or EXIT MENUS



OWN NUMBER or CALL INFO



ERASE or BACK OUT OF MENU

Special characters

Your phone supports English, French, Spanish, and Portuguese displays. If you select the English display, the number keys enter the letters printed on the keys. If you select another language, you can also enter letters with accents, cedillas, circumflexes, and other marks. To select a language, press the  key under [MENU], then press **6 7** to open the Display > Language menu.

Press the keys as indicated below to enter special characters. The lower case order is the same as the upper case order.

Key	French	Spanish	Portuguese
	A Â Ã B C Ç 2	A À Á Â B C Ç 2	A Á B C 2
	D E Ê Ë É Ê F 3	D E È É Ê F 3	D E É F 3
	G H I Î Ï 4	G H Í 4	G H Í 4
	M N O Ô Õ 6	M N O Ò Ó Ô Õ 6	M N Ñ O Ó 6
	T U Ü Ú V 8	T U Ü Ú V 8	T U Ü Ú V 8

NAVIGATION TIPS



MOVE LEFT or SCROLL UP



[MENU] ENTER MENU STRUCTURE



MOVE RIGHT or SCROLL DOWN



[BOOK] VIEW PHONE BOOK

Entering pauses and hyphens

You can save pauses and manual hyphens along with numbers. Pauses are useful for dialing numbers like voice mail access lines or any numbers that require a security code or credit card number. There are two kinds of pauses.





Timed pauses are two seconds long.

Hard pauses cause the phone to stop dialing until you press the  key under [RESUME].

Hyphens are only for show. You can insert manual hyphens wherever you like, while automatic hyphenation inserts hyphens according to the North American numbering plan. Entering a manual hyphen suspends any automatic hyphenation for that number.

Pauses and manual hyphens count towards the 32 characters in the number.

... To enter a pause or hyphen

1. Start entering the number.
2. Press  to insert a pause or manual hyphen.
3. Press one of the following keys:
 -  to insert a hard pause
 -  to insert a timed pause
 -  to insert a manual hyphen
4. Enter the rest of the numbers and the name as usual.

NAVIGATION TIPS



DIAL or ANSWER



HANG UP or EXIT MENUS





OWN NUMBER or CALL INFO





ERASE or BACK OUT OF MENU

Example

Suppose you want to save the phone number and code for your voice mail at work. To access your voice mail, you must dial a number, then enter a password, then press Pound () . Here is what you should do.

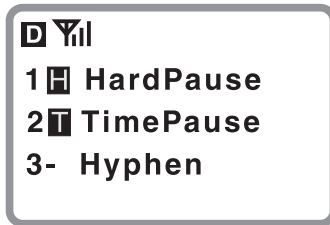
1. Enter the voice mail phone number.
2. Press  . The Pause/Hyphen screen appears.



3. Press 2 to select TimePause. *The screen returns to the entry screen. A "T" appears after the phone number.*
4. Enter the password, then the  key.
5. Press the  key under [SAVE].
6. Follow the directions on the screen to finish saving the entry.

When you dial this memory location, it calls your voice mail number. Two seconds after it connects, it automatically enters your password and the Pound key.

NAVIGATION TIPS



MOVE LEFT or SCROLL UP



[MENU] ENTER MENU STRUCTURE





MOVE RIGHT or SCROLL DOWN



[BOOK] VIEW PHONE BOOK



Dialing from the phone book

If you forget the memory location number... Press the  key under [BOOK]. Press  or  to scroll up or down through the phone book until you see the memory location number and its associated entry. You can also search for the entry by name (see “Searching the phone book” on page 28).



*** To speed dial a number

- From standby mode, enter the memory location number and press .

*** To dial from a memory location

1. Press the  key under [BOOK].
2. Scroll to the phone book entry.
3. When the on-screen cursor appears beside the phone number, press  to place the call.

Touch dialing

Use this menu-activated feature to call numbers without pressing . If touch dialing is not active on your phone, press the  key under [MENU] and press 5 6 to go to the Features > One Touch menu item. Select **Enabled** to activate touch dialing.

NAVIGATION TIPS



DIAL or ANSWER



HANG UP or EXIT MENUS



OWN NUMBER or CALL INFO





ERASE or BACK OUT OF MENU

... To use touch dialing

- From standby mode, enter the memory location number on the keypad. Hold down the last digit until you see the message "Calling..." along with the phone book data.

... To edit a number "on the fly"

You can change a number from the phone book or recent history list right before dialing. For instance, you may want to add long distance codes when dialing outside your home system.

1. Recall the number from the phone book or recent history list.
2. Press a character, such as , to start editing. Add or delete numbers as you wish.
3. If you wish, press the  key under [SAVE] to save the edited number to the phone book. *If you do not save the number, the changes only apply to the current call.*
4. Press  to dial the edited number.

NAVIGATION TIPS



MOVE LEFT or SCROLL UP



[MENU] ENTER MENU STRUCTURE



MOVE RIGHT or SCROLL DOWN









[BOOK] VIEW PHONE BOOK

Changing the phone book

... To edit a phone book entry

You can change the phone number, name, and memory location of any non-secret phone number. You can also make non-secret numbers secret.

Press the  key under [SAVE] to skip over a screen without changing anything, or to accept the changes you have made and move to the next step.

1. Press the  key under [BOOK]. *The [BOOK] Smart Key changes to [VIEW].*
2. Go to the phone book entry.
3. Press the  key under [VIEW] to see details of the entry. *The [EDIT] and [ERASE] Smart Keys appear.*
4. Press the  key under [EDIT]. *The number appears by itself. You cannot edit secret entries.*
5. Edit the phone number if you wish, using , , , and the digit keys.
6. Edit the name if you wish.
7. Edit the memory location number if you wish.
8. Save the entry as secret or non-secret.

When you finish making all your changes, a confirmation message appears on the screen.

NAVIGATION TIPS



DIAL or ANSWER



HANG UP or EXIT MENUS







OWN NUMBER or CALL INFO



ERASE or BACK OUT OF MENU

... To erase a phone book entry

1. Press the  key under [BOOK]. *The [BOOK] Smart Key changes to [VIEW].*
2. Go to the phone book entry.
3. Press the  key under [VIEW] if necessary to see details of the entry. *The [EDIT] and [ERASE] Smart Keys appear.*
4. Press the  key under [ERASE], then press the  key under [OK] to confirm that you want to erase the memory location.

"-erased-" appears on the display to indicate that you successfully deleted the entry.

Erasing secret numbers

If you try to erase a secret phone book entry, the phone asks you to enter your four-digit lock code. The default lock code is typically 0000 or the last four digits of your phone number. The Security > New Code menu option (4 3) lets you change your code to one that only you know.

NAVIGATION TIPS



MOVE LEFT or SCROLL UP



[MENU] ENTER MENU STRUCTURE



MOVE RIGHT or SCROLL DOWN





[BOOK] VIEW PHONE BOOK



Searching the phone book

The phone automatically sorts the phone book by memory location number. To sort the entries alphabetically, change the setting in the Display > Sort Book menu option (6 2).

... To scroll through the phone book

1. Press the  key under [BOOK].
2. Use  or  to scroll up or down through the list.

... To search by name

1. Press the  key under [BOOK]. *The [MENU] Smart Key changes to [NAME] and the [BOOK] Smart Key changes to [CALLS].*
2. Press the  key under [NAME]. *The [NAME] Smart Key changes to [FIND].*
3. Enter the first letter of the name, or enter part of a name (such as "ave" for "Dave") and press the  key under [FIND]. *The Name search is not case sensitive, so it does not matter whether you enter an upper or lower case letter.*

If you enter a single letter, the display shows the first name in the list that begins with that letter. If no name in the list begins with that letter, the display shows the next entry in alphabetical order.

N A V I G A T I O N T I P S



DIAL or ANSWER



HANG UP or EXIT MENUS



OWN NUMBER or CALL INFO



ERASE or BACK OUT OF MENU



Example

To search for "Peter", enter the letter "P." If there is no entry for Peter, the phone shows the next entry after the "P"s. If the next entry was in the "R"s, you might see the entry for "Rabbits by Ralph."

If you enter three or more consecutive letters in the name, the display shows the first name that contains those letters. For example, if you enter the letters "C-A-K-E," the phone might show the entry for "Heidi's Hotcakes."

... To search by phone number

To search for a number in the phone book, all you need to do is remember three consecutive digits. If more than one number contains those digits, the phone lists them all. Use the volume keys to scroll up or down the list.

1. From standby mode, enter three or more consecutive digits of the number. *As soon as you enter the third digit, the [BOOK] Smart Key changes to [FIND].*
2. Press the  key under [FIND].
3. Press  to dial the number.

... To search by memory location

1. Press the  key under [BOOK].
2. Enter the two-digit memory location number, such as **02** for the second entry. *The phone book entry appears.*

N A V I G A T I O N T I P S

- | | | | |
|---|---------------------------|---|-----------------------------|
|  | MOVE LEFT or SCROLL UP |  | [MENU] ENTER MENU STRUCTURE |
|  | MOVE RIGHT or SCROLL DOWN |  | [BOOK] VIEW PHONE BOOK |

[VOICE MAIL, PAGES, AND TEXT MESSAGES]

Many portable phones come with voice mail service. When your phone is turned off, calls automatically go to your voice mail. Some service providers allow people to send short messages such as pages or email to your phone.

Types of messages



Voice mail. When you receive a voice message, the voice mail system sends a notification to your phone. You must call your voice mail service to hear the message, since it is stored on their system and not on your phone.

Page/Msg. When a caller enters a number into your voice mail instead of a voice message, it appears on your phone as a numeric page. Some operators can also send numeric pages or preset text messages. If you have email service for your phone, email may appear as a text message. You can view pages and messages on your phone display.

Alerts

When you receive voice mail or short messages, your phone alerts you in three ways:

- A message on the display says "Page/Msg" or "Voice Mail." Asterisks indicate that the message is urgent.
- An envelope icon, which blinks if the message is urgent.
- Four beeps. To turn off the beep, go to the Volume > Message Volume menu item (2 4).

Press  to open the message screen. Use the volume keys to scroll to "Voice" or "Page/Msg." Press the  key under [OK] to view the messages.

Memory

Your phone can store up to 700 bytes of messages, which is approximately 23 16-character messages.

When the available memory falls to less than 25% of the total memory, the phone beeps and displays a "Low Memory" message.

When the phone runs out of memory, it beeps and displays the message "Out of Memory." It does not accept any new messages. When this happens, erase old or unimportant messages to free up some memory.

N A V I G A T I O N T I P S



MOVE LEFT or SCROLL UP



[MENU] ENTER MENU STRUCTURE



MOVE RIGHT or SCROLL DOWN







[BOOK] VIEW PHONE BOOK

Voice mail



Each voice mail notification automatically erases the previous notification. It does not erase the actual message in your voice mail.

... To listen to your voice mail

1. When  and "Voice Mail" appear, press . The [MENU] and [BOOK] Smart Keys change to [OK] and [NET].
2. Scroll to the "Voice" line on the display, then press the  key under [OK] to view the notification.
3. If a callback number for your voice mail service appears, press  to dial it. If there is no callback number, return to standby mode and dial your voice mail service.
4. Follow the recorded prompts on the voice mail system to listen to your message.

... To erase voice mail notifications

Erasing the voice mail notification does not erase any of the messages on your voice mail system.

1. While viewing the voice mail notification, press the  key under [ERASE] to delete it.
2. Press the  key under [YES] to confirm that you want to erase.

N A V I G A T I O N T I P S



DIAL or ANSWER



HANG UP or EXIT MENUS







OWN NUMBER or CALL INFO





ERASE or BACK OUT OF MENU

Pages and text messages



*** To view a page or text message

1. When  and "Page/Msg" appear, press .
2. Scroll to the "Page/Msg" line, then press the  key under [OK]. *The first new message opens. If there are no new messages, a list of old messages appears.*
3. Press the  key under [VIEW] to look at a message.



*** To dial a callback number

1. After viewing the message, press .
2. If the message includes a callback number, press  again to dial it.

*** To save a callback number

1. After viewing the message, press .
2. Press the  key under [SAVE] to save the number to the phone book.

*** To erase a page or text message

1. After viewing the message, press the  key under [ERASE].
2. Press the  key under [YES] to confirm that you want to erase.

NAVIGATION TIPS

- | | | | |
|---|---------------------------|---|-----------------------------|
|  | MOVE LEFT or SCROLL UP |  | [MENU] ENTER MENU STRUCTURE |
|  | MOVE RIGHT or SCROLL DOWN |  | [BOOK] VIEW PHONE BOOK |

[MENUS]

Menus allow you to check or change phone settings. This section illustrates the menu structure, explains how to use menus, and defines each menu item.

Diagram

Notice that each menu except the Keyguard menu contains a secondary list of menu items. As usual, the Smart Keys will change depending on what screen you are in.

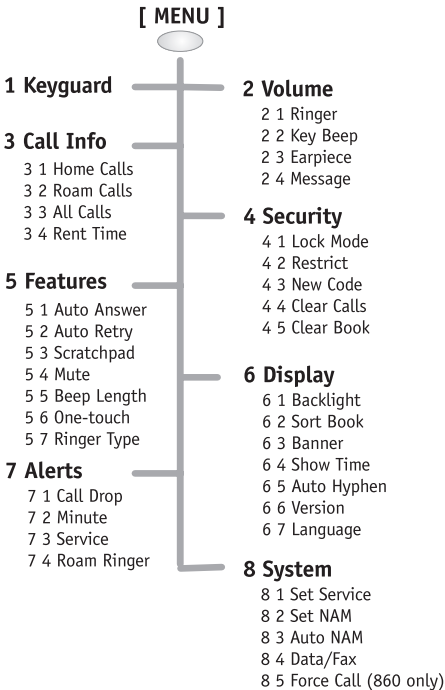



*** To enter the menu structure



1. Press the  key under [MENU]. *A list of the menus appears.*
2. Press the number that corresponds to the menu you want to open. *You must provide your lock code to open the Security menu.*
3. Press the number of the item you want.

Note: Since the Keyguard menu does not contain any menu items, selecting the menu number is enough to toggle the setting. In other cases, selecting the menu opens a list of menu items.







*** To set a menu item

1. Press the  key under [NEXT] to cycle through the options.
2. When you see the option you want, press the  key under [OK]. *A check mark appears beside the selected option.*

*** To back up

- Press  once to cancel out of the current menu item or return to the previous menu level without saving changes.
- Press  once to return to standby mode without saving changes.

N A V I G A T I O N T I P S

	MOVE LEFT or SCROLL UP		[MENU]	ENTER MENU STRUCTURE
	MOVE RIGHT or SCROLL DOWN		[BOOK]	VIEW PHONE BOOK
	[NEXT]CYCLE MENU SETTINGS		[OK]	SELECT MENU SETTING

Menu item descriptions

1. Keyguard

This feature disables the keypad to protect your phone against accidental key presses. See “Using the keyguard” on page 8 for more details.

2. Volume

The items in this menu enable you to adjust the volume of the ringer, keys, earpiece, and incoming message alert. Different menu items appear if your phone is attached to the Hands-free Car Kit or the Hands-free Headset: for example, Car Spkr Volume and Headset Volume.

2-1. Ringer Adjusts the ringer volume. You can also adjust the ringer volume with the volume keys on the side of the phone when the phone is ringing or in standby mode. Possible settings: **off**, **escalate**, **low**, **M-**, **M+**, **high**.

2-2. Key Beep Adjusts the key beep volume. Possible settings: **off**, **low**, **M-**, **M+**, **high**.

2-3. Earpiece Adjusts the earpiece volume. You can also adjust the volume during a call by pressing the volume keys on the side of the phone. There are seven volume levels.

NAVIGATION TIPS



DIAL or ANSWER



HANG UP or EXIT MENUS



OWN NUMBER or CALL INFO





ERASE or BACK OUT OF MENU

Press [MENU] Smart Key, menu number, then menu item number to open menu







- 2-4. **Message** Adjusts the incoming message alert beep. Possible settings: **off**, **low**, **M-**, **M+**, **high**.

3. Call info

The items in this menu allow you to see the number and duration of various kinds of calls. Duration is always measured in minutes and seconds.

- 3-1. **Home calls** Displays the duration of all calls you made in your home system (that is, not roaming) since the last reset. Press the  key under [RESET] to reset.
- 3-2. **Roam Calls** Displays the duration of all calls you made outside your home system since the last reset. Press the  key under [RESET] to reset.
- 3-3. **All Calls** Displays the duration of all calls you have made on your phone. You cannot reset this menu item.
- 3-4. **Rent Time** Displays the number and duration of all calls according to your billing plan. This menu option may not be present or active on all phones. See your service provider for any questions. Press the  key under [RESET] to reset.

NAVIGATION TIPS

- | | | | | |
|---|---------------------------|---|--------|----------------------|
|  | MOVE LEFT or SCROLL UP |  | [MENU] | ENTER MENU STRUCTURE |
|  | MOVE RIGHT or SCROLL DOWN |  | [BOOK] | VIEW PHONE BOOK |
|  | [NEXT]CYCLE MENU SETTINGS |  | [OK] | SELECT MENU SETTING |

4. Security

You must enter your four-digit lock code to open the Security menu. The default lock code is usually either 0000 or the last four digits of your phone number. If you forget your lock code, call your service provider.

- 4-1. **Lock Mode** Activates a security lock using your four-digit lock code. You can only call emergency numbers or receive incoming calls. To unlock the phone, press the  key under [UNLOCK] and enter your lock code. Possible settings: **on power up, now** (resets to **never** when you unlock), **never**.

- 4-2. **Restrict** Limits your outgoing calls to emergency numbers, designated service provider numbers, and the numbers in the phone book. You may answer incoming calls and view or dial the phone book numbers, but you cannot erase, add, or edit any numbers. Possible settings: **yes, no**.

- 4-3. **New Code** Allows you to change your lock code.

- 4-4. **Clear Calls** Erases the recent history list.

- 4-5. **Erase Book** Erases the entire phone book. *There is no undo feature.*

N A V I G A T I O N T I P S



DIAL or ANSWER



HANG UP or EXIT MENUS



OWN NUMBER or CALL INFO









ERASE or BACK OUT OF MENU

Press [MENU] Smart Key, menu number, then menu item number to open menu

5. Features

- 5-1. **Auto Answer** Sets the phone to automatically pick up after two rings. This feature is useful in combination with the Hands-free Car Kit. Possible settings: **on**, **off**.
- 5-2. **Auto Retry** Redials failed calls five times or until the call goes through. Auto Retry works when the system is busy or unavailable, not when the phone line is busy. Possible settings: **every 60 seconds**, **every 30 seconds**, **every 10 seconds**, **off**.
- 5-3. **Scratchpad** Lets you add phone numbers to the recent history list during a call without sounding key beeps. The scratchpad is only active during calls. Press the  key under [ADD] to save entry.
- 5-4. **Mute** Switches the microphone on and off during a call. When the microphone is off, the other party cannot hear you. Possible settings: **on**, **off**. See also "To mute a call" on page 15.
- 5-5. **Beep Length** Sets key beep length and touch tone playback speed. **Normal** length emits a short beep. **Long** emits a beep for as

N A V I G A T I O N T I P S

	MOVE LEFT or SCROLL UP		[MENU]	ENTER MENU STRUCTURE
	MOVE RIGHT or SCROLL DOWN		[BOOK]	VIEW PHONE BOOK
	[NEXT]CYCLE MENU SETTINGS		[OK]	SELECT MENU SETTING

long as you hold down a key. Possible settings: **normal, long**.

5-6. **One Touch** Enables touch dialing. See “Touch dialing” on page 24 to learn how to use this feature. Possible settings: **enable, disable**.

5-7. **Ringer Type** Sets the sound of the incoming call alert. Press the  key under [NEXT] to cycle through the settings. Each ring plays automatically. Possible settings: **standard, options 1 - 9**.

6. Display

6-1. **Backlight** The backlight illuminates the phone display and keypad. It remains on whenever the phone receives power from an external source, such as the Cigarette Lighter Adaptor (Model # TXCLA031) or Hands-free Car Kit (Model # TXCKT031). Possible settings: **always off, 10 seconds** (turns off 10 seconds after the last key press), **30 seconds**.

6-2. **Sort Book** Sorts phone book entries. Possible settings: **alphabetic, location #**.

6-3. **Banner** Up to 12 characters that appear on the display during power up and standby.

N A V I G A T I O N T I P S



DIAL or ANSWER



HANG UP or EXIT MENUS





OWN NUMBER or CALL INFO









ERASE or BACK OUT OF MENU

Press [MENU] Smart Key, menu number, then menu item number to open menu

- Press the  key under [EDIT] to create or change your banner. Enter characters the same way you do for the phone book (see “Saving a name with the number” on page 19).
- 6-4. Show Time** Displays the date and time during standby mode. Possible settings: **yes, no.**
- 6-5. Auto Hyphen** Hyphenates phone numbers according to the North American numbering plan. Automatic hyphenation does not affect dialing in any way, nor does it count towards the 32-digit limit in the phone book. Possible settings: **on, off.**
- 6-6. Version** Displays the software version and product model of your phone. Press the  key under [MORE] for more information, such as your electronic serial number (ESN).
- 6-7. Language** Sets the language that appears on the phone. Enables you to use the number keys to type accented characters as well as the letters that appear on the keys. See “Special characters” on page 21 for a list. Possible settings: **English, Français, Portugues, Español.**

 NAVIGATION TIPS

- | | | | | |
|---|---------------------------|---|--------|----------------------|
|  | MOVE LEFT or SCROLL UP |  | [MENU] | ENTER MENU STRUCTURE |
|  | MOVE RIGHT or SCROLL DOWN |  | [BOOK] | VIEW PHONE BOOK |
|  | [NEXT]CYCLE MENU SETTINGS |  | [OK] | SELECT MENU SETTING |

7. Alerts

- 7-1. **Call Drop** The phone beeps and shows a message when you drop a call. Possible settings: **on, off**.
- 7-2. **Minute** The Minute Minder alert beeps ten seconds before each minute during a call. This helps you track your phone use. Possible settings: **on, off**.
- 7-3. **Service** The Service alert beeps when a network service parameter changes. For instance, it beeps if you move out of your service area and start roaming (which could lead to higher costs), or if the call changes from digital to the less-secure analog service. Possible settings: **on, off**.
- 7-4. **Roam Ringer** Assigns a distinct ring to incoming calls that occur when you are roaming. Possible settings: **on, off**.

N A V I G A T I O N T I P S



DIAL or ANSWER



HANG UP or EXIT MENUS



OWN NUMBER or CALL INFO



ERASE or BACK OUT OF MENU

Press [MENU] Smart Key, menu number, then menu item number to open menu





8. System

The items on this menu enable you to set network options.

8-1. Set Service Determines which signals your phone will accept. **Automatic**, the default and recommended setting, accepts whatever system the phone service provides. **No Roaming** prevents you from making or receiving any calls outside the home system. The QCP-860 phone has two other options, **A Side** and **B Side**. They refer to the two cellular blocks. By selecting one block, you prevent your phone from operating on the other block. Possible settings: **Automatic**, **A Side** (QCP-860 only), **B Side** (QCP-860 only), **No Roaming**.

8-2. Set NAM If you have phone accounts with multiple service providers, use this menu item to set your NAM (Number Assignment Module) correctly for your current area. For instance, if you travel frequently between two cities, you might have a phone account set up in each city. When you are in City A, use this menu item to change to your City A account. If you do *not* have a NAM in

N A V I G A T I O N T I P S

	MOVE LEFT or SCROLL UP		[MENU]	ENTER MENU STRUCTURE
	MOVE RIGHT or SCROLL DOWN		[BOOK]	VIEW PHONE BOOK
	[NEXT]CYCLE MENU SETTINGS		[OK]	SELECT MENU SETTING

City A, then all your phone calls would be “roaming” calls and would incur higher charges.

8-3. Auto NAM Allows the phone to automatically switch to one of the programmed NAMs when it detects the appropriate network signal. Leave the setting at “off” unless you have accounts with multiple service providers. Possible settings: **on, off**.

8-4. Data/Fax Determines whether the phone can receive both voice and data calls, or just data calls. **No**, the default setting, allows both *if* your phone network can distinguish between voice and data. **Next call** forces the next call into data mode. **All calls** forces the phone into data mode. These settings remain until you reset the menu to **No** or turn off the phone. Possible settings: **no, next call, all calls**.

8-5. Force Call This menu item only appears on the QCP-860 dual-mode phone. It forces the phone into analog mode until the end of the next incoming or outgoing call, or for the next ten minutes.

N A V I G A T I O N T I P S



DIAL or ANSWER



HANG UP or EXIT MENUS



OWN NUMBER or CALL INFO



ERASE or BACK OUT OF MENU

Press [MENU] Smart Key, menu number, then menu item number to open menu

[CARING FOR YOUR PHONE]

Use the following guidelines to optimize the performance and life of your phone, antenna, and battery.

Phone

- **Do not let unauthorized personnel install or service your phone or accessories.** Faulty installation or service may be dangerous, and will invalidate your warranty.
- **Only use QUALCOMM-approved accessories with QUALCOMM phones.** Use of any unauthorized accessories may be dangerous and will invalidate your phone warranty if said accessories cause damage or a defect to the phone.
- **Keep it dry.** If the phone gets wet, turn the power off immediately and remove the external battery. Let it dry before you use it again. If the phone is inoperable, return it to the dealer for service.
- **Treat it gently.** Although your phone is quite resilient, it is a complex piece of hardware and can be broken. Use common-sense guidelines to avoid dropping it, hitting it, bending it, or sitting on it. You can add to the phone's safety and style by obtaining the fitted Leather Case (Model # TXLCC031).

Antenna

Follow these guidelines to get the best reception possible.

- Fully extend the antenna when you place or receive a call.
- Do not touch the antenna while you are on a call.
- Do not bend or twist the antenna.

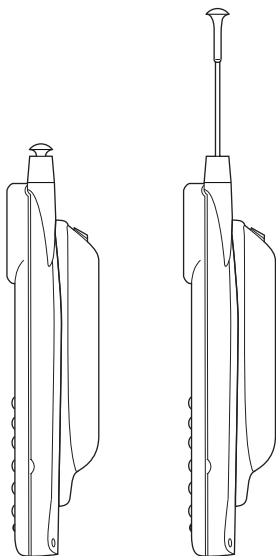

Antenna down

Antenna up

S029_02

NAVIGATION TIPS



DIAL or ANSWER



HANG UP or EXIT MENUS



OWN NUMBER or CALL INFO



ERASE or BACK OUT OF MENU

Battery

Your phone comes with an internal LiIon battery (illustrated below) that provides excellent talk and standby time. Leave this battery in the phone at all times. You can purchase external batteries that snap onto the back of the phone for extended talk and standby time.

LiIon batteries do not have any “memory effect,” so you can safely recharge the battery whenever you want. You can recharge the battery for years before it shows any sign of age.

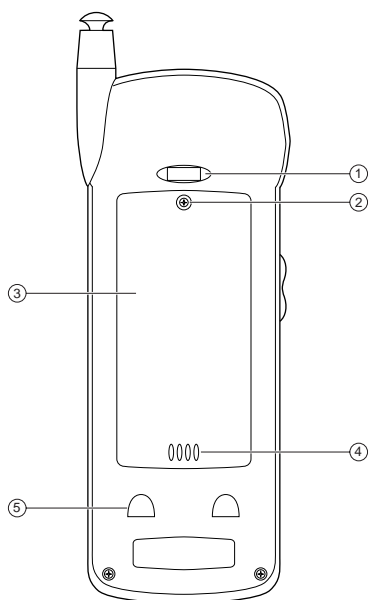

S029_03A

NAVIGATION TIPS



MOVE LEFT or SCROLL UP



[MENU] ENTER MENU STRUCTURE





MOVE RIGHT or SCROLL DOWN



[BOOK] VIEW PHONE BOOK

- 1. Latch** Holds the top of the external battery in place.
- 2. Screw** Holds the internal battery in place. Do not remove the internal battery at any time. If you ever need to replace the internal battery, have your QUALCOMM service center install a replacement.
- 3. Internal battery** The internal battery is flush with the back surface of the phone.
- 4. Contacts** The external battery rests against these contacts, which allow it to transmit energy to the phone.
- 5. Slots** The two “teeth” at the base of the external battery fit into these slots. The combination of the teeth and the latch hold the external battery firmly in place.

Resetting the phone

On rare occasions, a portable wireless phone may “lock up.” This is usually due to a temporary computer chip malfunction. If this happens, press , , and  at the same time. Please note that Lilon batteries are very reliable and provide extra-long talk and standby times.

NAVIGATION TIPS



DIAL or ANSWER



HANG UP or EXIT MENUS



OWN NUMBER or CALL INFO



ERASE or BACK OUT OF MENU

External batteries

You can snap an optional external battery onto the back of your phone. The external battery does not replace the internal battery, but provides extra-long talking and standby time. The convenient Hot Swapping feature prevents you from dropping calls when one battery is low (see “Hot swapping” on page 51).

You can choose from various external battery options, such as the External Slim LiIon Battery (Model # TXBAT032) or the External Extended LiIon Battery (Model # TXBAT033), shown below.



No external battery

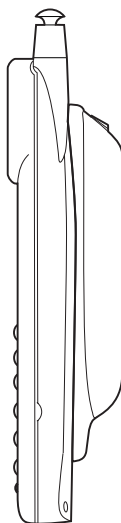

With External Slim battery

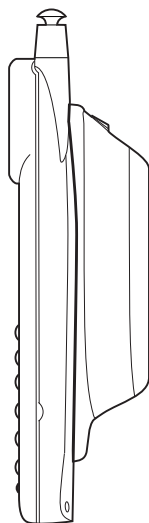

With External Extended battery

S029_53A

NAVIGATION TIPS



MOVE LEFT or SCROLL UP



[MENU] ENTER MENU STRUCTURE



MOVE RIGHT or SCROLL DOWN



[BOOK] VIEW PHONE BOOK

*** To attach an external battery

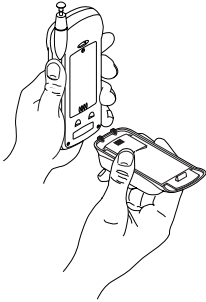

1. Insert the two teeth on the battery into the corresponding holes on the back of the phone.

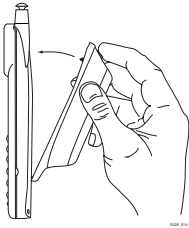

2. Rotate the top of the battery towards the phone until it latches into place.

*** To remove an external battery

1. Push the button on the top of the battery cartridge to disengage the battery.
2. Pull the battery away from the phone.

Caution: It is illegal in some areas to dispose of LiIon batteries in household or business trash. Contact your nearest QUALCOMM Service Center for safe disposal options. Do not handle a damaged or leaking LiIon battery.

NAVIGATION TIPS



DIAL or ANSWER



HANG UP or EXIT MENUS



OWN NUMBER or CALL INFO



ERASE or BACK OUT OF MENU

Battery power levels

The phone uses all the power in the external battery before it starts to use the internal battery.

The battery icon only tracks one battery at a time. It reflects the charge level of the external battery (if attached) as long as it has a charge. Otherwise, it tracks the internal battery level. The more black bars there are, the fuller the battery is.



When your battery is very low, the icon on your display blinks, the phone beeps, and a message alerts you to the low battery level. Press the  key under [OK] to acknowledge the message.

Tip: To reduce unnecessary drain on your battery, turn backlighting to “always off.” (See “Display” on page 40.)

Hot swapping

If the external battery runs out of power during a call, the internal battery takes over automatically. This is called **hot swapping**. When you acknowledge the low battery message and remove the external battery, the battery icon starts displaying the status of the internal battery.

NAVIGATION TIPS



MOVE LEFT or SCROLL UP



[MENU] ENTER MENU STRUCTURE



MOVE RIGHT or SCROLL DOWN



[BOOK] VIEW PHONE BOOK

If your internal battery falls low during a call, just snap on an external battery. The phone automatically starts drawing from the external battery without dropping the call. The battery icon starts displaying the charge level of the external battery.

Follow these guidelines to improve battery performance.

- Do not disassemble or short-circuit the battery.
- Keep the metal contacts at the base of the battery clean.
- If you have not used an internal or external battery for more than a month, recharge it before using it.
- Replace the internal battery when it no longer maintains a charge.
- Do not use any battery in direct sunlight or in places with high humidity, such as the bathroom.
- Never dispose of any battery in or by a fire. It could explode.
- Do not charge any battery if the temperature is below 32°F (0°C) or above 122°F (50°C).
- Do not store any battery in hot areas for long periods of time. Follow these storage guidelines:
under 1 month: -4°F (-20°C) to 140°F (60°C)
over 1 month: -4°F (-20°C) to 113°F (45°C)

N A V I G A T I O N T I P S



DIAL or ANSWER



HANG UP or EXIT MENUS



OWN NUMBER or CALL INFO



ERASE or BACK OUT OF MENU

Charging accessories

There are several charging accessories available for your phone. You can use the accessories with or without an external battery attached to your phone. Consult the documentation that came with the charging accessory to find out standard charging times and operating details. All charging times are estimates and may vary.

If an external battery is attached to your phone, the charging accessories charge the internal battery first, then the external battery.

You do not need to completely discharge any of the LiIon batteries before recharging them. Unlike some batteries, there is no memory effect that degrades performance.

Cigarette Lighter Adaptor (Model # TXCLA031).

This accessory lets you plug your phone into the cigarette lighter on your car's dashboard. The internal phone battery charges itself off the car battery in about two hours. Charging stops when you are on a call.

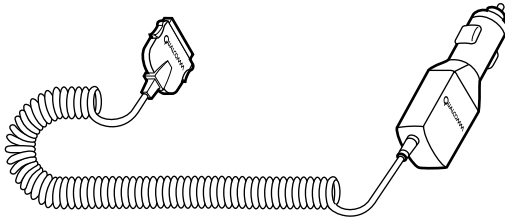

NAVIGATION TIPS



MOVE LEFT or SCROLL UP



[MENU] ENTER MENU STRUCTURE



MOVE RIGHT or SCROLL DOWN



[BOOK] VIEW PHONE BOOK

Hands-free Car Kit (Model # TXCKT031). Like the Cigarette Lighter Adaptor, this accessory charges the internal phone battery off your car battery in about two hours, then starts charging the external battery. The microphone and speaker attachments let you use your phone in hands-free mode. This may increase your safety while driving.

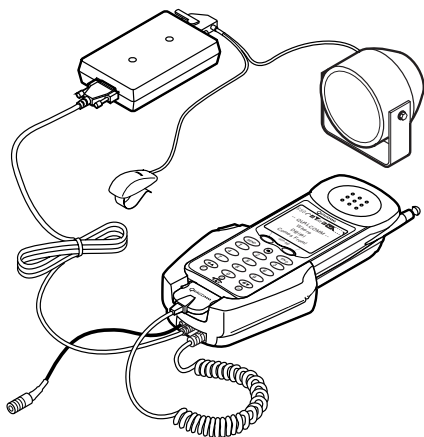

S029_66A

Desktop Charger (Model # TXDTC031). Set the desktop charger on a flat surface and plug it into the wall. The charger can hold up to three batteries: the phone with an internal battery, an attached external battery, and a second external battery in the rear port of the charger. The charger recharges the internal battery in about two hours, then starts charging the external battery.

NAVIGATION TIPS



DIAL or ANSWER



HANG UP or EXIT MENUS



OWN NUMBER or CALL INFO



ERASE or BACK OUT OF MENU

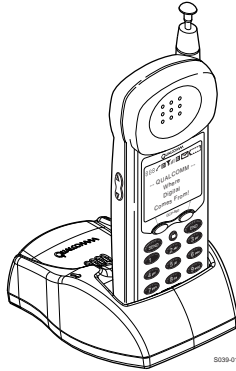

Global Travel Charger (Model # TXTVL031). Plug the AC adaptor into a standard wall outlet and plug the other end into your phone. Use commercially available plug adaptors for international use. The charger recharges the internal battery in two or three hours, then starts charging the external battery.

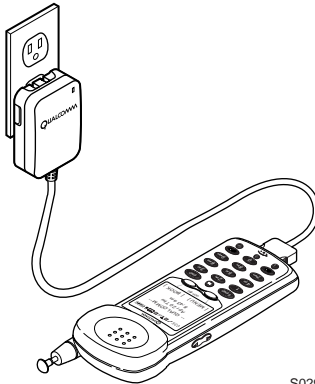

NAVIGATION TIPS



MOVE LEFT or SCROLL UP



[MENU] ENTER MENU STRUCTURE



MOVE RIGHT or SCROLL DOWN



[BOOK] VIEW PHONE BOOK

Power save mode

Your phone automatically switches to a power-save mode if it has not found a signal after about 15 minutes of searching. Power-save mode decreases the drain on the battery.

When the phone is in power-save mode, you cannot make or receive calls. "Power Save Mode" and the No Signal icon () appear on the display.

The phone periodically rechecks for a signal. Press any key to manually check for service. When the phone finds a signal, it automatically switches out of power-save mode and displays the Signal Strength icon () at the top of the display.

NAVIGATION TIPS



DIAL or ANSWER



HANG UP or EXIT MENUS



OWN NUMBER or CALL INFO



ERASE or BACK OUT OF MENU

[SAFETY INFORMATION]

Radio Frequency (RF) energy

Your telephone is a radio transmitter and receiver. When it is on, it receives and also sends out RF energy. Your service provider's phone network controls the power level of the RF signal. This power level can range from 0.006 watts to 0.6 watts.

Exposure to RF energy

In August 1996, the U.S. Federal Communications Commission (FCC) adopted RF exposure guidelines with safety levels for hand-held wireless phones. These guidelines are consistent with the safety standards previously set by both U.S. and international standards bodies in the following reports:

ANSI C95.1 (American National Standards Institute, 1992)

NCRP Report 86 (National Council on Radiation Protection and Measurements, 1986)

ICNIRP (International Commission on Non-Ionizing Radiation Protection, 1996)

Your phone complies with the standards set by these reports and the FCC guidelines.

Medical devices

Pacemakers. If your portable wireless phone is too close to a pacemaker, the phone's RF energy may interfere with the pacemaker's operation. The Health Industry Manufacturers Association and the wireless technology research community recommend that you follow these guidelines to minimize the potential for interference.

- Always keep the phone at least six inches (15 centimeters) away from your pacemaker when the phone is turned on.
- Do not carry your phone near your heart.
- Use the ear opposite the pacemaker.
- If you have any reason to suspect that interference is taking place, turn your phone off immediately.

Hearing aids. Some digital wireless phones may interfere with hearing aids. In the event of such interference, you may want to consult your service provider or call the customer service line to discuss alternatives.

Other medical devices. If you use any other personal medical device, consult the manufacturer of the device to determine if it is adequately shielded from external RF energy. Your physician may be able to help you obtain this information.

NAVIGATION TIPS



DIAL or ANSWER



HANG UP or EXIT MENUS



OWN NUMBER or CALL INFO



ERASE or BACK OUT OF MENU

In health care facilities. Turn your phone off in health care facilities when instructed. Hospitals and health care facilities may be using equipment that is sensitive to external RF energy.

Potentially unsafe areas

Posted facilities. Turn your phone off in any facility when posted notices require you to do so.

Aircraft. FCC regulations prohibit using your phone on a plane that is in the air. Turn your phone off before boarding aircraft.

Vehicles. RF signals may affect improperly installed or inadequately shielded electronic systems in motor vehicles. Check with the manufacturer or its representative regarding your vehicle. You should also consult the manufacturer of any equipment that has been added to your vehicle.

Blasting areas. To avoid interfering with blasting operations, turn your phone off when you are in a blasting area or in areas posted "Turn off two-way radio." Obey all signs and instructions.

Potentially explosive atmospheres. Turn your phone off when you are in any area with a potentially explosive atmosphere. Obey all signs and instructions. Sparks in such areas could cause an explosion or fire resulting in bodily injury or even death.

N A V I G A T I O N T I P S



MOVE LEFT or SCROLL UP



[MENU] ENTER MENU STRUCTURE



MOVE RIGHT or SCROLL DOWN



[BOOK] VIEW PHONE BOOK

Areas with a potentially explosive atmosphere are often, but not always, clearly marked. They include

- fueling areas such as gas stations
- below deck on boats
- transfer or storage facilities for fuel or chemicals
- vehicles using liquefied petroleum gas, such as propane or butane
- areas where the air contains chemicals or particles such as grain, dust, or metal powders
- any other area where you would normally be advised to turn off your vehicle engine

Emergency numbers

Emergency numbers are a special kind of speed dial number. You can dial an emergency number any time the phone is on and receiving a signal, unless you have activated the keyguard.

NAVIGATION TIPS



DIAL or ANSWER



HANG UP or EXIT MENUS



OWN NUMBER or CALL INFO



ERASE or BACK OUT OF MENU

Driving safely

Before you use your phone while driving, check the local laws and regulations on the use of portable wireless phones in vehicles. Always obey them, and exercise caution while driving.

The following ten guidelines for using your phone while driving are based on a list provided by the Cellular Telecommunications Industry Association (CTIA).

1. **Get to know your wireless phone and its features, such as speed dial (page 16) and redial (page 11).** These features help you to place your call without taking your attention off the road.
2. **When available, use a hands free device.** Add additional convenience and safety to your wireless phone with one of QUALCOMM's hands-free accessories, such as the Hands-free Car Kit (Model # TXCKT031) and the Hands-free Headset (Model # TXCKT031, shown below).

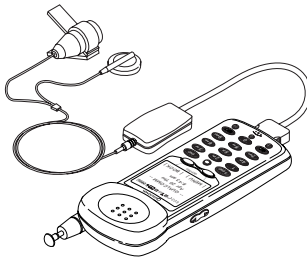

S029_63A

NAVIGATION TIPS



MOVE LEFT or SCROLL UP



[MENU] ENTER MENU STRUCTURE



MOVE RIGHT or SCROLL DOWN



[BOOK] VIEW PHONE BOOK

3. **Position your wireless phone within easy reach.**
Be able to access your wireless phone without removing your eyes from the road. If you get an incoming call at an inconvenient time, let your voice mail answer it for you.
4. **Let the person with whom you are speaking know you are driving.** If necessary, suspend the call in heavy traffic or hazardous weather conditions.
5. **Do not take notes or look up phone numbers while driving.** Jotting down a "to do" list or scrolling through your phone book takes attention away from your primary responsibility: driving safely.
6. **Dial sensibly.** If you need to make a call while moving, dial only a few numbers, check the road and your mirrors, then continue. If possible, place calls when you are not moving or before pulling into traffic.
7. **Do not engage in stressful or emotional conversations.** Make people with whom you are talking aware that you are driving. Suspend conversations that have the potential to divert your attention from the road.
8. **Use your wireless phone to call for help.** Dial 9-1-1 or other local emergency number in the case of fire, traffic accident, or medical emergencies.
Remember, it is a free call on your wireless phone!

N A V I G A T I O N T I P S



DIAL or ANSWER



HANG UP or EXIT MENUS



OWN NUMBER or CALL INFO



ERASE or BACK OUT OF MENU

9. **Use your wireless phone to help others in emergencies.** If you see an auto accident, crime in progress, or other serious emergency where lives are in danger, call 9-1-1 or other local emergency number, as you would want others to do for you.
10. **Call roadside assistance or a special non-emergency wireless assistance number when necessary.** If you see a broken-down vehicle posing no serious hazard, a broken traffic signal, a minor traffic accident where no one appears injured, or a vehicle you know to be stolen, call roadside assistance or other special non-emergency wireless number.

For more information, call 1-888-901-SAFE (in the U.S.) or visit CTIA's website at wow-com™ (<http://www.wow-com.com>).

Failure to follow these instructions may lead to serious personal injury and possible property damage.

Air bags

If you have an air bag, DO NOT place installed or portable phone equipment or other objects over the air bag or in the air bag deployment area. Air bags inflate with great force. If equipment is carelessly placed or not properly installed, you or your passengers risk serious injury.

NAVIGATION TIPS



MOVE LEFT or SCROLL UP



[MENU] ENTER MENU STRUCTURE



MOVE RIGHT or SCROLL DOWN



[BOOK] VIEW PHONE BOOK

[INDEX]

A

- AC Adaptor 9
- accessories
 - Cigarette Lighter Adaptor 53
 - Desktop Charger 54
 - Global Travel Charger 55
 - Hands-free Car Kit 54
 - Hands-free Headset 61
 - Leather Case 45
 - use QUALCOMM only 2, 45
- adjusting volume 6, 36
- air bags, safety considerations 63
- aircraft safety 59
- alerts
 - change in service 42
 - dropped calls 42
 - low power 51
 - menu 42
 - message 31
 - minute 42
 - setting volume 36
- analog mode 3
 - alert 42
 - forcing 44
- answering calls
 - automatic pickup 39
 - with number keypad 7
 - with Pound key 7
 - with Send key 7
 - with Star key 7
- antenna 1, 46

B

- backing up
 - Clear key 8
 - End key 7
 - in menus 8, 35
- backlight 40
 - reducing battery drain 51
- banner 40

batteries

- charge icon 4, 51
 - charging 9, 47
 - external 9, 49
 - hot swapping 49, 51
 - improving performance 52
 - internal LiIon 47
 - memory effect 47, 54
 - power save mode 56
 - reducing drain 51
 - resetting phone 48
 - beep length 39
 - beep volume 36
 - billing
 - change in service alert 42
 - minute alert 42
 - roaming 4
 - blasting areas 59
- ## C
- Call Info menu 37
 - caller ID 13, 14
 - calls
 - call waiting 14
 - dialing from memory location 24
 - dialing from the keypad 10
 - dropped 42
 - duration 37
 - emergency numbers 60
 - forwarding 14
 - hot swapping 49
 - information about 7
 - muting 15, 39
 - on recent history list 12
 - optimal reception 46
 - restricting 38
 - speed dialing 24
 - three-way 13
 - touch dialing 24

cancel out of screen 7, 8
 care and maintenance 45–56
 CDMA

advantages 3
 enhanced 4

characters
 case 19
 entering letters 19
 international 21
 punctuation 20

charging batteries 47
 AC Adaptor 9
 accessories 53
 Cigarette Lighter Adaptor 53
 Desktop Charger 54
 Global Travel Charger 9, 55
 Hands-free Car Kit 54
 level too low 9

Cigarette Lighter Adaptor 53
 backlight 40

Clear key 8
 backing up 8, 35
 erasing 8
 standby mode 5

credit card dialing 22

D

data, forcing 44
 date, showing on display 41
 Desktop Charger 54

digital mode
 advantages of 3
 alert 42
 forcing 44
 icon 3

display
 banner 40
 battery charge icon 4
 date and time 41
 digital mode icon 3
 envelope icon 4
 meaning of icons 3
 menu 40
 no signal icon 3
 on call icon 4
 padlock icon 4
 roaming icon 4
 signal strength icon 3

driving safety 61–63
 air bags 63
 guidelines 61
 Hands-free Car Kit 54, 61
 Hands-free Headset 61
 RF energy 59
 dropped calls 42
 hot swapping 49
 duration of calls 37

E

earpiece volume 15, 36
 editing
 erasing 8
 moving the cursor 6, 7
 phone book number,
 temporarily 25
 recent history list 12
 electronic serial number (ESN) 41
 email 30

as short message 33
 digital mode 44
 force data mode 44

emergency numbers 60
 End key 7
 exiting menus 35
 standby mode 5

ending calls 7
 entering
 data from keypad 7
 letters 17, 19
 long distance information 25
 punctuation 20
 special characters 21
 upper and lower case 19

envelope icon 4, 7

erasing 8
 entire phone book 38
 pages 33
 phone book entry 27
 recent history list 38
 secret numbers 27
 text messages 33
 voice mail notification 32

explosive areas 59
 external batteries 9, 49
 attaching 50
 benefits 49

- charging 53
- removing 50

F

- Features menu 39
- forcing analog mode 44
- forwarding calls 14
- French
 - characters 21
 - language option 41

G

- Global Travel Charger 9, 55

H

- Hands-free Car Kit 54
 - auto answer 39
 - backlight 40
 - driving safety 61
 - volume menu options 36
- Hands-free Headset
 - driving safety 61
 - volume menu options 36
- hanging up 7, 10
- hearing aids 58
- hot swapping 49, 51
- hyphens
 - automatic 41
 - manual 22

I

- Information key 7
 - punctuation 20
- internal battery 47
 - charge level 51

K

- keyguard 2
 - directions for 8
 - menu 36
 - padlock icon 4
- keys 6–8
 - beep length 39
 - beep volume 36
 - Clear 8
 - End 7
 - Information 7
 - Message 7
 - number keypad 7

- Pound (down) 7
- Power 8
- Send 7
- Smart keys 7
- Star (up) 7
- volume 6, 36

L

- language
 - entering special characters 21
 - menu option 41
- Leather Case 45
- letters
 - changing case 19
 - entering from keypad 19
 - international characters 21
 - punctuation 20
- Lilon batteries 9
 - external 49
 - internal 47
- lock code
 - changing 38
 - default 38
 - erasing secret numbers 27
- long distance information 25

M

- making calls 10
 - call waiting 14
 - forwarding 14
 - hanging up 10
 - no signal 3
 - Send key 7
 - signal strength 3
 - speed dialing 24
 - three-way calling 13
- medical devices and portable phones 58
- memory
 - low 31
 - out of 31
- memory location 16
 - assigning 17
 - dialing from 24
 - if you forget 24
 - searching by 29
 - touch dialing 25
- menus 34–44

- Alerts 42
 - backing up 8, 35
- Call Info 37
 - diagram 35
- Display 40
- exiting 35
- Features 39
- Keyguard 36
 - opening 35
 - scrolling 6
- Security 38
- selecting options 7, 35
- System 43
- Volume 36

Message key 7

messages

- alerts 31
- envelope icon 4
- Message key 7, 31
- phone memory 31
- types of 30

minute alert 42

moving the cursor

- Pound key 7
- Star key 7
- volume keys 6

multiple phone accounts 43

muting calls 15, 39

N

NAM

- setting automatically 44
- setting manually 43

names

- banner 40
- length 16
- saving with phone number 19
- searching by 28

no signal icon 3

number keypad 7

O

on call icon 4

one-touch dialing

- See touch dialing

own phone number 1

- Information key 7

P

pacemaker

- safety guidelines 58
- using phone with 2

padlock icon 4

pages

- calling back 33
- envelope icon 4
- erasing 33
- Message key 7
- saving callback number 33
- viewing 33
- See messages

pauses

- hard 22
- timed 22

performance

- antenna 46
- batteries 52
- phone 45
- power save mode 56

phone book 16–29

- adding long distance information 25
- definition of 16
- dialing from memory location 24

editing 26

- entering names 19
- entering numbers 17

entry length 16

erasing entire 38

erasing entry 27

hyphens 22

memory locations 16

pauses 22

punctuation 20

- saving number from recent history list 11

searching 28

secret numbers 18

sorting 28

special characters 21

speed dialing 16, 24

- temporarily changing number 25

touch dialing 24

- phone numbers
 - searching by 29
 - viewing your own 1
- Portuguese
 - characters 21
 - language option 41
- Pound key 7
- Power key 8
- power save mode 56
- privacy
 - enhanced CDMA voice privacy 4
 - locking phone 38
 - secret phone book numbers 18
- punctuation characters 20

R

- radio frequency energy *See* RF energy
- receiving calls
 - answering 10
 - hanging up 10
 - messages 4
 - no signal 3
 - signal strength 3
 - when phone is off 10
- recent history list
 - adding numbers with scratchpad 39
 - duplicate calls 12
 - editing 12
 - erasing 38
 - redialing last ten numbers 11
 - saving number into phone book 11
 - types of calls 12
 - viewing call information 11
- reception 46
- recharging batteries *See* charging batteries
- redialing
 - auto retry 39
 - from recent history list 11
 - last number dialed 11
 - See* recent history list
- resetting the phone 48
- restricting calls 38
- RF energy 57

- exposure 57
- medical devices, safety 58
- unsafe areas 59

- ringer
 - adjusting volume 15, 36
 - roaming 42
 - silencing 6, 7, 15
 - type 40
- roaming
 - alert 42
 - distinctive ring 42
 - duration of calls 37
 - icon 4
 - set service options 43

S

- safety 57–63
 - air bags 63
 - authorized personnel 45
 - auto answer 39
 - emergency numbers 60
 - keyguard 2, 8
 - medical devices 58
 - pacemaker 2
 - phone tips 45
 - RF energy 57
 - unsafe areas 59
- saving
 - callback number 33
 - name with phone number 19
 - number from recent history list to phone book 11
 - number into phone book 17
- scratchpad 39
- screen *See* display
- scrolling
 - Pound key 7
 - Star key 7
 - volume keys 6
- searching the phone book
 - by memory location 29
 - by name 28
 - by phone number 29
 - scrolling 28
- secret numbers 18
 - erasing 27
 - no editing 26
- Security menu 38

- Send key 7
- service alert 42
- service area, roaming 4
- service provider features
 - call forwarding 14
 - call waiting 14
 - caller ID 13
 - restricting calls 38
 - three-way calling 13
- short message services 30–33
- signal strength icon 3
- silencing
 - mouthpiece 39
 - ringer 6, 15
- Smart Keys 5, 7
- software version 41
- sorting the phone book 28, 40
- Spanish
 - characters 21
 - language option 41
- speed dialing 16, 24
- standby mode
 - Clear key 5
 - definition of 5
 - End key 5
 - returning to 7, 8
 - viewing own phone number 7
- standby time
 - battery charge icon 4
 - external battery 9, 49
- Star key 7
- System menu 43
- T**
- talk time
 - battery charge icon 4
 - external battery 9, 49
- text messages
 - erasing 33
 - viewing 33
- three-way calling 13
- time
 - of calls 37
 - show on display 41
- touch dialing 24
 - example 25
 - menu option 40
- travel *See* Global Travel Charger
- turning off the phone 1
 - Power key 8
- turning on the phone 1
 - charging the batteries 9
 - Power key 8
- V**
- viewing
 - pages 33
 - text messages 33
 - voice mail notification 32
- voice mail
 - driving safety 62
 - envelope icon 4
 - erasing notification 32
 - listening to 32
 - Message key 7
 - viewing notification 32
 - See* messages
- voice quality 3
 - raising antenna 46
- volume
 - earpiece 15, 36
 - key beep 36
 - menu 36
 - message alert 37
 - muting call 15
 - ringer 36
 - silencing ringer 15
 - volume keys 6